

INW-AM95

Installation Guide

INWALL BOX FOR AM95

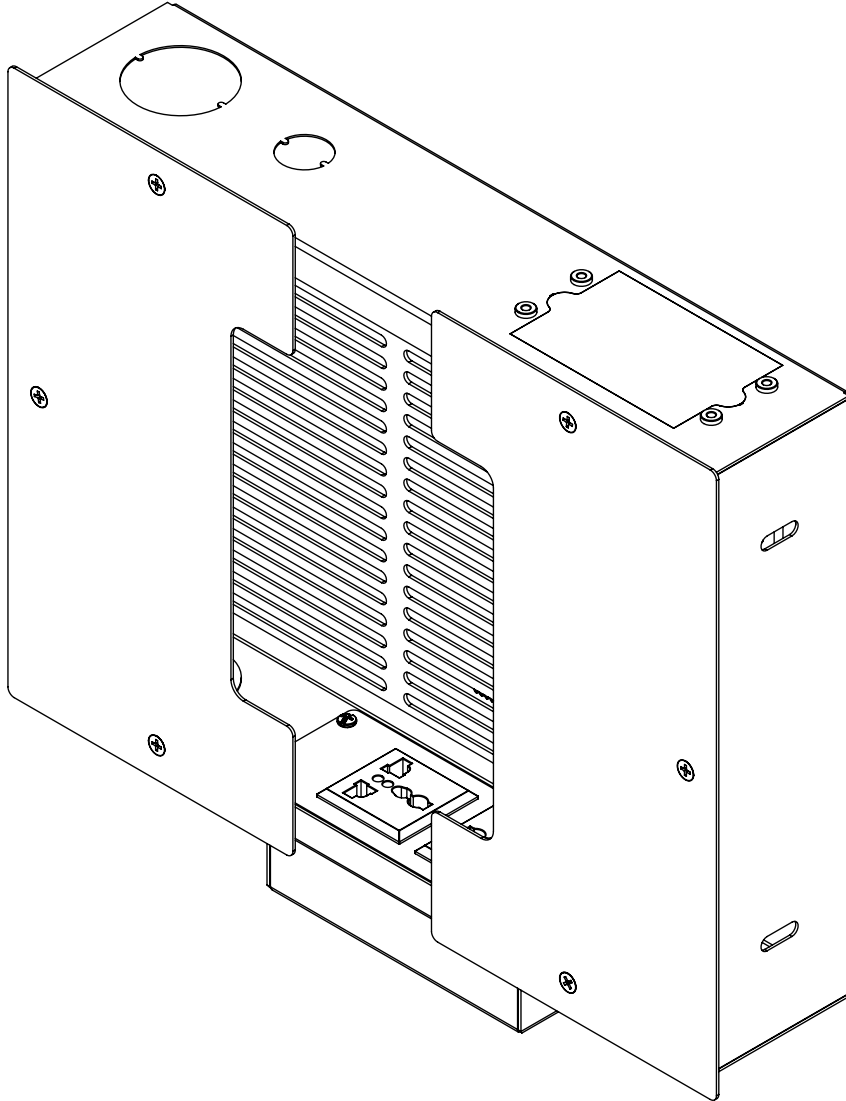

INW-AM95

Installation Guide

Included Components:

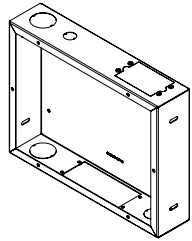

x1

In-wall Mount

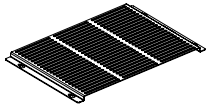

x1

Rack Mount

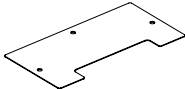

Front Cover

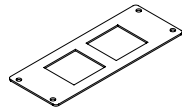

x1

Snap in Plug Plate

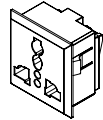

x2

Universal Power Socket



x4

M4 x 6mm Comb. Screw

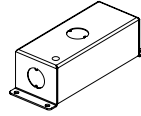

x1

Snap In Socket



x2

#10 x 2 Wood Screw



x4

M4 x 8mm Comb. Screw



x1

8/32- 3/8" Ground Screw



x4

Zip Tie



x6

8/32" x 1/4" Flat Head Screw

1

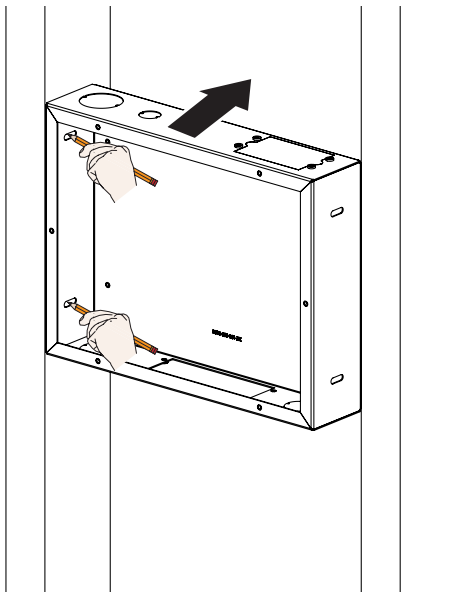

Find your desired location and mark the mounting locations.

2

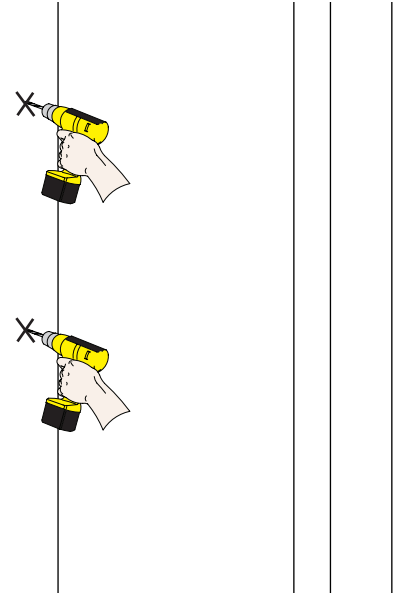

Drill a pilot hole using a 5/32" drill bit.

INW-AM95 Installation Guide

3

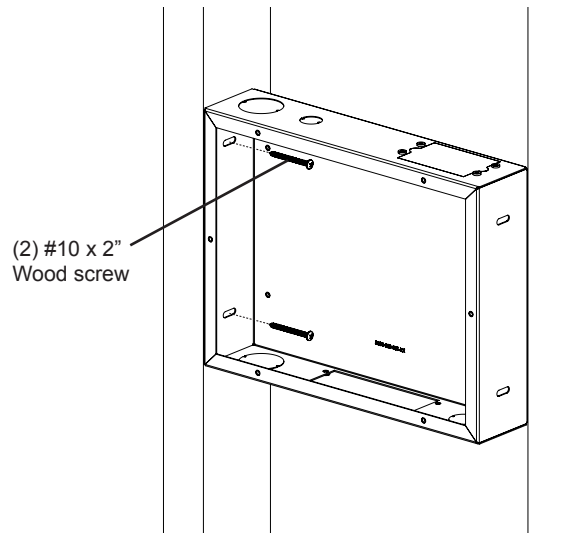

Drill the wood screws to the stud.

4A

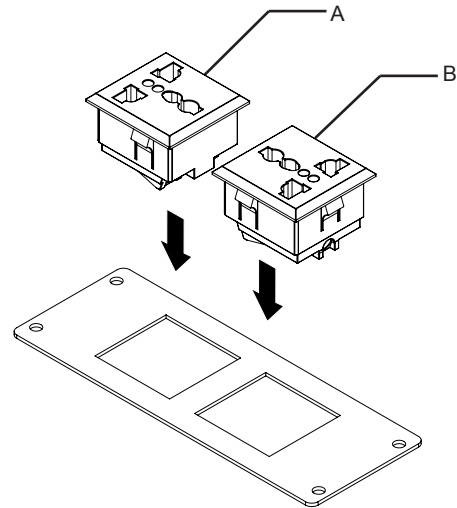

A. Media Player / Set top Box
B. Display

4B

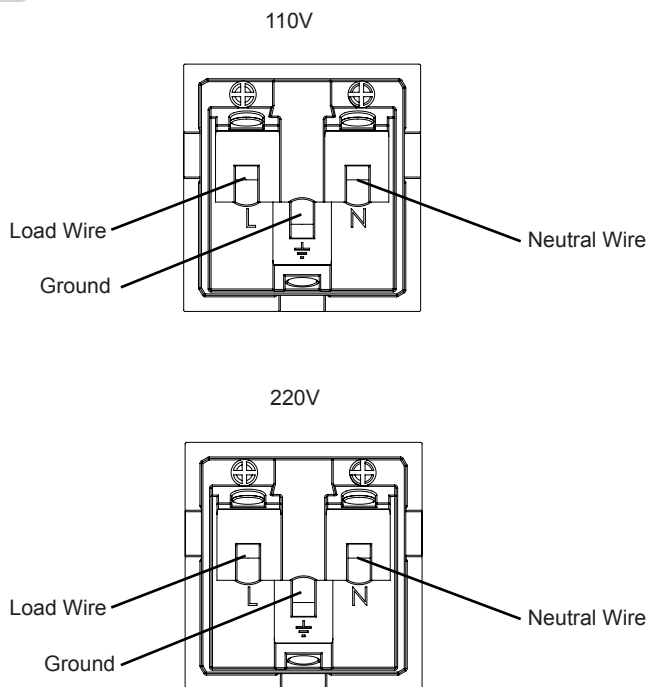

5

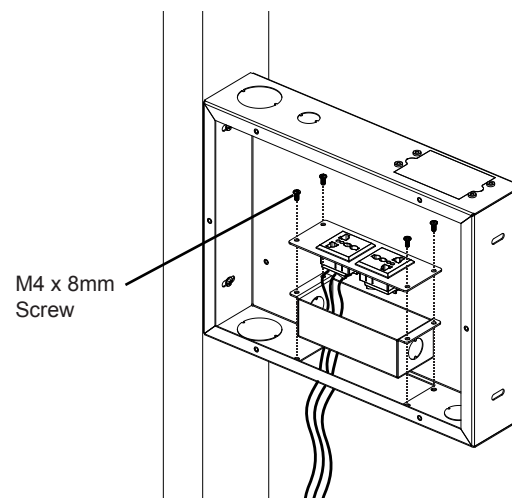

1. Put the wires up through the electrical box.
2. Use a # 2 Phillips screw driver to install four (4) M4 x8 mm screws.

INW-AM95

Installation Guide

6

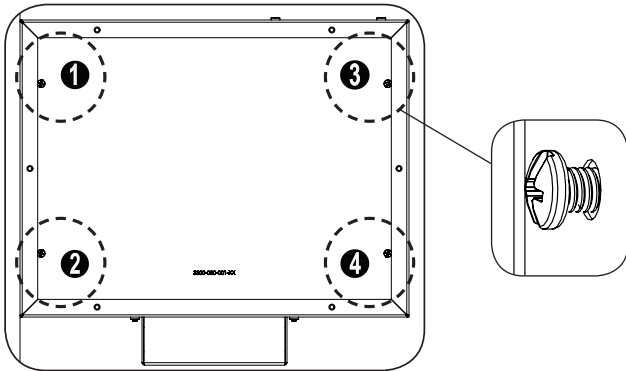

Lightly install four (4) M4 x 6mm screws inside the in-wall box.

7

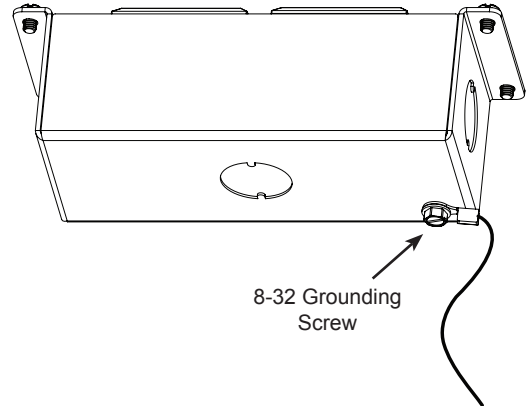

Connect the ground to the outlet box with the provided ground screw.

8

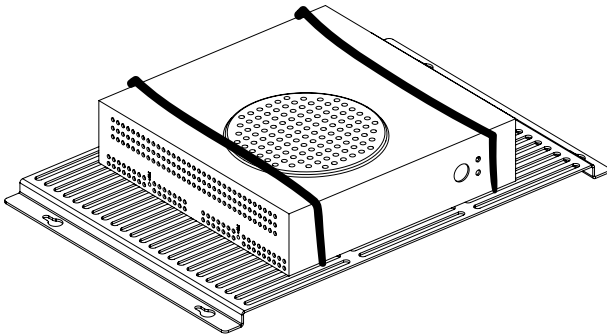

Secure the media player to the rack mount using the supplied zip ties.

9

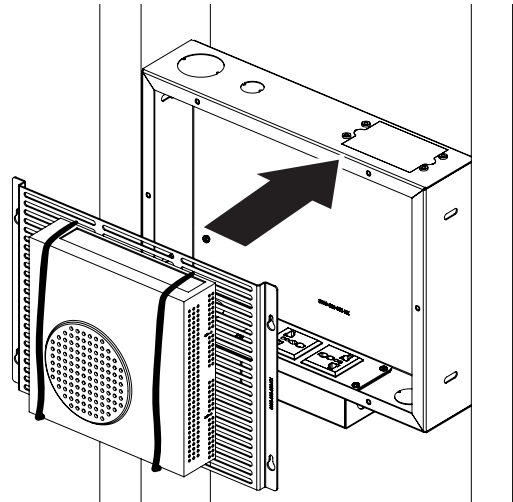

1. Insert the key slot holes onto the screws inside the in-wall box.
2. Tighten the four (4) M4 x 6 mm screws.

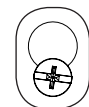

Key slot

10

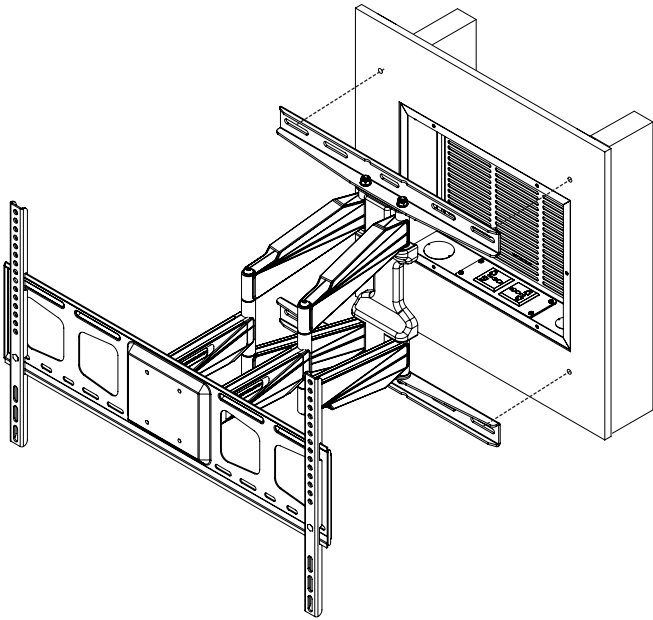

1. Center the AM95 to the in-wall box.
2. Refer to the AM95 installation manual to mount the AM95.

11

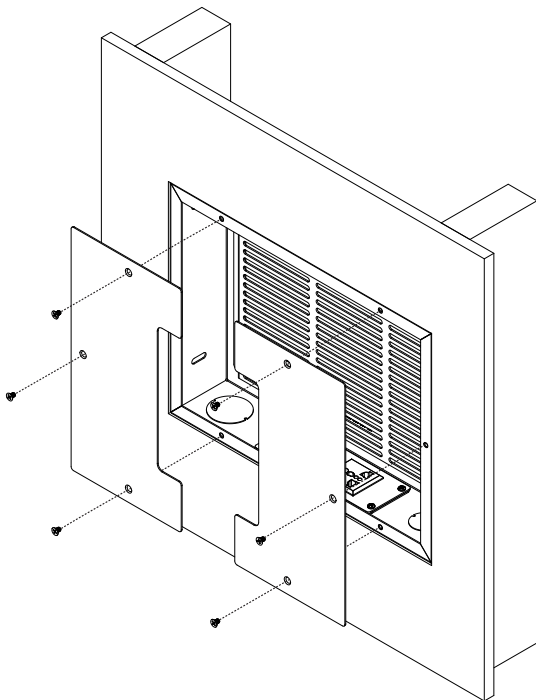

Install the (2) two front covers to the in-wall box using (6) six 8/32" x 1/4" flat head screws.

AM95 not shown for clarity.

PRODUCT DIMENSION

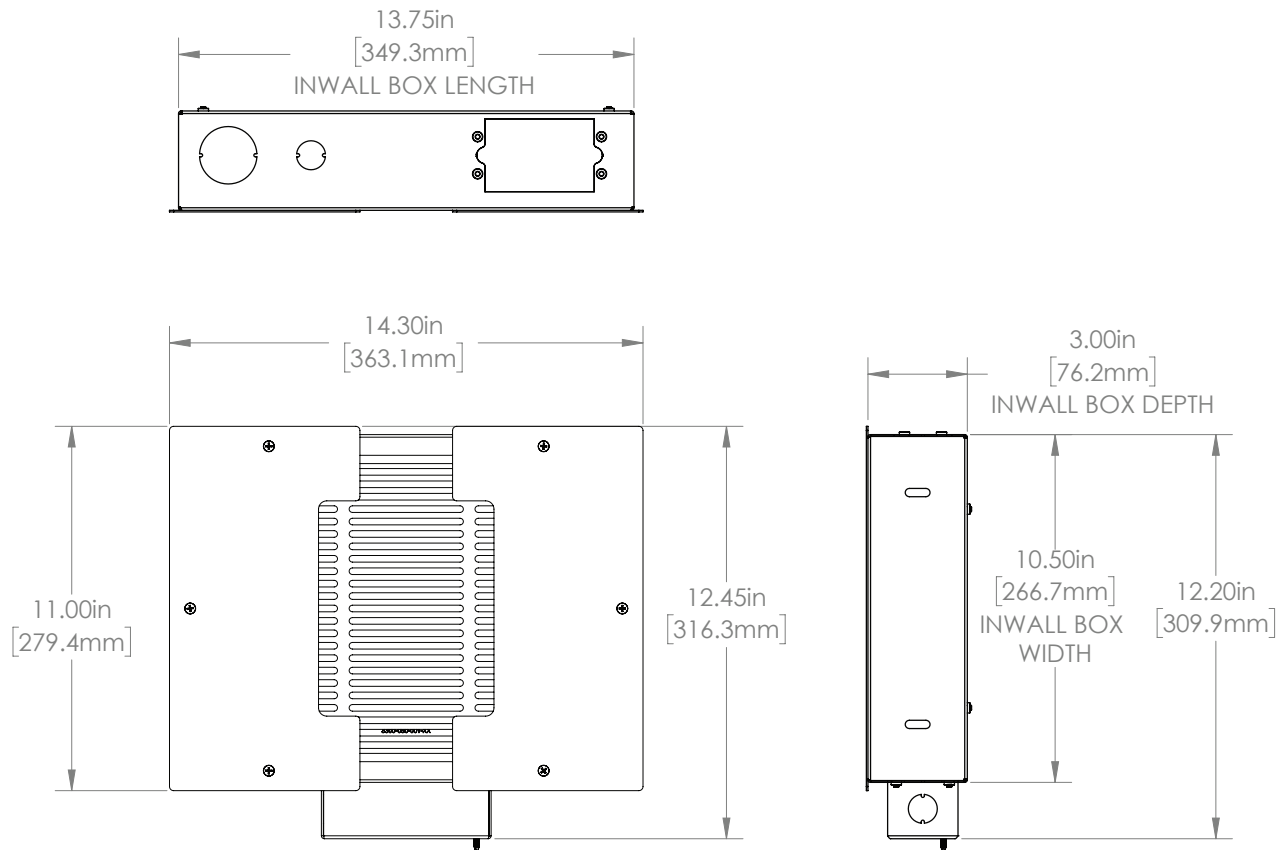

PREMIER MOUNTS
LIMITED LIFETIME WARRANTY

What and Who is Covered by this Limited Lifetime Warranty

Premier Mounts warrants all mounting products to be free from defects in material and workmanship for the lifetime of the original installation of the product.

What Premier Mounts Will Do

At the sole option of Premier Mounts, Premier Mounts will repair or replace any product or product part that is defective. If Premier Mounts chooses to replace a defective product or part, a replacement product or part will be shipped to you at no charge, but you must pay any related labor costs.

What is Not Covered: Limitations

Premier Mounts disclaims any liability for damage to mounts, adapters, displays, projectors, other property, or personal injury resulting, in whole or in part, from improper installation, modification, use or misuse of its products.

NOTWITHSTANDING ANYTHING TO THE CONTRARY IN THIS WARRANTY, THIS WARRANTY IS LIMITED TO FIVE YEARS FROM THE DATE OF PURCHASE IN THE EVENT THAT THE WARRANTED PRODUCT IS COMMERCIALY RENTED OUT.

Electrical products and components, such as amplifiers, speakers, motors, switches remote controls and related electrical items, are backed by a 3-year warranty.

Premier Mounts disclaims all other warranties, express or implied, including warranties of merchantability and fitness for a particular purpose. Premier Mounts is not responsible for incidental or consequential damages, including but not limited to, inability to use its products or labor costs for removing and replacing defective products or parts. Some states do not allow the exclusion or limitation of incidental or consequential damages, so the above limitation or exclusion may not apply to you.

What Customers Must Do for Warranty Service

If you discover a problem that you think may be covered by the warranty, you must report it in writing to the address below within thirty (30) days. Proof of purchase (an original sales receipt) from the original consumer purchaser must accompany all warranty claims. Warranty claims must also include a description of the problem, the purchaser's name, address, and telephone number. General inquiries can be addressed to Premier Mounts Customer Service at 1-800-368-9700. Warranty claims will not be accepted over the phone or by fax.

Premier Mounts
Attn: Warranty Claim
2620 Palisades Drive
Corona, 92882 CA, USA

How State Law Applies

This warranty gives you specific legal rights, and you may also have other rights which vary from state to state.

Premier Mounts intends to make this manual accurate and complete. However, Premier Mounts makes no claim that the information contained herein covers all details, conditions or variations, nor does it provide for every possible contingency in connection with the installation or use of this product. The information contained in this document is subject to change without notice or obligation of any kind. Premier Mounts makes no representation of warranty, expressed or implied, regarding the information contained herein. Premier Mounts assumes no responsibility for accuracy, completeness or sufficiency of the information contained in this document.

