



SRX240 Services Gateway

Hardware Guide



Published: 2014-06-10

Juniper Networks, Inc.
1194 North Mathilda Avenue
Sunnyvale, California 94089
USA
408-745-2000
www.juniper.net

Juniper Networks, Junos, Steel-Belted Radius, NetScreen, and ScreenOS are registered trademarks of Juniper Networks, Inc. in the United States and other countries. The Juniper Networks Logo, the Junos logo, and JunosE are trademarks of Juniper Networks, Inc. All other trademarks, service marks, registered trademarks, or registered service marks are the property of their respective owners.

Juniper Networks assumes no responsibility for any inaccuracies in this document. Juniper Networks reserves the right to change, modify, transfer, or otherwise revise this publication without notice.

SRX240 Services Gateway Hardware Guide
Copyright © 2014, Juniper Networks, Inc.
All rights reserved. Printed in USA.

Revision History
October 2013
June 2014—Added the EMC compliance requirements in Israel

The information in this document is current as of the date on the title page.

SOFTWARE LICENSE

The terms and conditions for using this software are described in the software license contained in the acknowledgment to your purchase order or, to the extent applicable, to any reseller agreement or end-user purchase agreement executed between you and Juniper Networks. By using this software, you indicate that you understand and agree to be bound by those terms and conditions.

Generally speaking, the software license restricts the manner in which you are permitted to use the software and may contain prohibitions against certain uses. The software license may state conditions under which the license is automatically terminated. You should consult the license for further details.

For complete product documentation, please see the Juniper Networks Web site at www.juniper.net/techpubs.

END USER LICENSE AGREEMENT

The Juniper Networks product that is the subject of this technical documentation consists of (or is intended for use with) Juniper Networks software. Use of such software is subject to the terms and conditions of the End User License Agreement ("EULA") posted at <http://www.juniper.net/support/eula.html>. By downloading, installing or using such software, you agree to the terms and conditions of that EULA.

Table of Contents

	About This Guide	ix
	Objectives	ix
	Audience	ix
	Documentation Conventions	ix
	SRX Series Documentation and Release Notes	xi
	Obtaining Documentation	xii
	Documentation Feedback	xii
	Requesting Technical Support	xii
	Self-Help Online Tools and Resources	xii
	Opening a Case with JTAC	xiii
Part 1	SRX240 Services Gateway Overview	
Chapter 1	Introduction to the SRX240 Services Gateway	3
	SRX240 Services Gateway Description	3
	SRX240 Services Gateway Models	4
	SRX240 Services Gateway Hardware Features	5
Chapter 2	SRX240 Services Gateway Hardware Components and Specifications	7
	SRX240 Services Gateway Chassis	7
	SRX240 Services Gateway Front Panel and Back Panel Views	9
	SRX240 Services Gateway Front Panel	9
	SRX240 Services Gateway Back Panel (AC power supply models)	11
	SRX240 Services Gateway Back Panel (DC Power Supply Model)	11
	SRX240 Services Gateway Built-In Interfaces	12
	SRX240 Services Gateway LEDs	14
	Front Panel LEDs	14
	Ethernet Port LEDs	16
	DC Power Supply Feed LEDs (SRX240 Services Gateway DC Power Supply Model)	17
	SRX240 Services Gateway Boot Devices and Dual-Root Partitioning Scheme	18
	Boot Devices	18
	Dual-Root Partitioning Scheme	19
	SRX240 Services Gateway Power Supply	20
	AC Power Supply (SRX240 Services Gateway)	20
	DC Power Supply (SRX240 Services Gateway with DC Power Supply Model)	20
	SRX240 Services Gateway Cooling System	21
	SRX240 Services Gateway Air Filter	21

Chapter 3	SRX240 Services Gateway Mini-Physical Interface Modules	23
	Mini-Physical Interface Modules for the SRX240 Services Gateway	23
Chapter 4	SRX240 Services Gateway Power over Ethernet Support	25
	SRX240 Services Gateway Power over Ethernet Overview	25
	Introduction	25
	PoE Classes and Power Ratings	26
	Configuring Power over Ethernet on the SRX240 Services Gateway	27
Part 2	Setting Up the SRX240 Services Gateway	
Chapter 5	Preparing the Site for the SRX240 Services Gateway Installation	31
	Site Preparation Checklist for the SRX240 Services Gateway	31
	General Site Guidelines for Installing the SRX240 Services Gateway	32
	SRX240 Services Gateway Rack Requirements	33
	Clearance Requirements for Airflow and Hardware Maintenance on the SRX240 Services Gateway	34
	SRX240 Services Gateway Electrical and Power Requirements	35
Chapter 6	Installation Overview for the SRX240 Services Gateway	37
	Installation Overview for the SRX240 Services Gateway	37
Chapter 7	Required Tools and Parts for Installing and Maintaining the SRX240 Services Gateway	39
	Required Tools and Parts for Installing and Maintaining the SRX240 Services Gateway	39
Chapter 8	Unpacking the SRX240 Services Gateway	41
	Unpacking the SRX240 Services Gateway	41
	Verifying Parts Received with the SRX240 Services Gateway	41
Chapter 9	Installing the SRX240 Services Gateway	43
	SRX240 Services Gateway Safety Requirements, Warnings, and Guidelines	43
	Preparing the SRX240 Services Gateway for Installation	43
	Installing the SRX240 Services Gateway	44
	Replacing or Installing Mini-Physical Interface Modules in the SRX240 Services Gateway	47
Chapter 10	Connecting, Grounding, and Powering On the SRX240 Services Gateway	49
	Connecting the SRX240 Services Gateway to the AC Power Source	49
	Connecting the SRX240 Services Gateway DC Power Supply Model to a DC Power Source	50
	Connecting and Organizing Interface Cables to the SRX240 Services Gateway	54
	Grounding the SRX240 Services Gateway	55
	Powering On and Powering Off the SRX240 Services Gateway	57
	Powering On the SRX240 Services Gateway	57
	Powering Off the SRX240 Services Gateway	57
	Resetting the SRX240 Services Gateway	59

Chapter 11	SRX240 Services Gateway Autoinstallation	61
	SRX240 Services Gateway Autoinstallation Overview	61
Chapter 12	Connecting the SRX240 Services Gateway to Management Devices	63
	Connecting to the SRX240 Services Gateway Setup Wizard	63
	Connecting the SRX240 Services Gateway to the CLI	64
	Connecting the Services Gateway to the CLI Locally	65
	Connecting a Services Gateway to the CLI Remotely	66
	Connecting the Modem at the SRX240 Services Gateway End	67
	Connecting the Modem to the Console Port on the SRX240 Services Gateway	68
	Connecting to the CLI at the User End for the SRX240 Services Gateway	69
Chapter 13	Performing Initial Software Configuration on the SRX240 Services Gateway	71
	SRX240 Services Gateway Software Configuration Overview	71
	Preparing the SRX240 Services Gateway for Configuration	71
	Understanding the Factory Default Configuration	72
	Understanding Built-In Ethernet Ports and Initial Configuration	72
	Mapping the Chassis Cluster Ports	73
	Understanding Management Access	74
	Performing Initial Software Configuration on the SRX240 Services Gateway Using the Setup Wizard	75
	About the Setup Wizard	75
	About the Default Setup Mode	76
	About the Guided Setup Mode	76
	Running the Setup Wizard	77
	Performing Initial Software Configuration on the SRX240 Services Gateway Using the CLI	78
	Performing Initial Software Configuration on the SRX240 Services Gateway Using the J-Web Interface	80
	Establishing Basic Connectivity	81
	Configuring Basic System Properties	82
	SRX240 Services Gateway Secure Web Access Overview	85
Part 3	Maintaining, Replacing, and Monitoring the SRX240 Services Gateway Hardware	
Chapter 14	Maintaining the SRX240 Services Gateway Hardware Components	89
	Maintaining the SRX240 Services Gateway Hardware Components	89
	Replacing the Air Filter on the SRX240 Services Gateway	90
Chapter 15	Monitoring the SRX240 Services Gateway	95
	Monitoring Hardware Components on the SRX240 Services Gateway	95
	Monitoring the SRX240 Services Gateway Chassis Using the CLI	95
	Monitoring the SRX240 Services Gateway Components Using LEDs	97

Monitoring the SRX240 Services Gateway Using Chassis Alarm	
Conditions	101
Monitoring the SRX240 Services Gateway Power System	103
Monitoring the SRX240 Services Gateway AC Power System	103
Monitoring the SRX240 Services Gateway DC Power System	104
Resetting the Configuration File When the SRX240 Services Gateway Is	
Inaccessible	105
Loading the Rescue Configuration on the SRX240 Services Gateway	105
Changing the Reset Config Button Behavior on the SRX240 Services	
Gateway	106
Juniper Networks Technical Assistance Center	106

Part 4

Appendixes

Appendix A

Safety and Regulatory Compliance Information	109
SRX240 Services Gateway Definition of Safety Warning Levels	109
SRX240 Services Gateway General Safety Guidelines and Warnings	111
General Safety Guidelines and Warnings	111
Qualified Personnel Warning	112
Restricted Access Area Warning	113
Preventing Electrostatic Discharge Damage to the Services Gateway	114
SRX240 Services Gateway Fire Safety Requirements	115
SRX240 Services Gateway Installation Safety Guidelines and Warnings	116
Installation Instructions Warning	116
Rack-Mounting Requirements and Warnings	118
SRX240 Services Gateway Laser and LED Safety Guidelines and Warnings	121
Laser and LED Safety Guidelines and Warnings	122
General Laser Safety Guidelines	122
Class 1 Laser Product Warning	122
Class 1 LED Product Warning	122
Laser Beam Warning	123
Radiation from Open Port Apertures Warning	123
SRX240 Services Gateway Maintenance and Operational Safety Guidelines and	
Warnings	125
Safety Guidelines and Warnings	125
Battery Handling Warning	125
Jewelry Removal Warning	126
Lightning Activity Warning	127
Operating Temperature Warning	128
Product Disposal Warning	129
SRX240 Services Gateway Electrical Safety Guidelines and Warnings	130
Electrical Safety Guidelines and Warnings	130
In Case of Electrical Accident	130
General Electrical Safety Guidelines and Warnings	130
Copper Conductors Warning	131
DC Power Electrical Safety Guidelines and Warnings	132
DC Power Electrical Safety Guidelines	132
DC Power Disconnection Warning	133
DC Power Grounding Requirements and Warning	134

	DC Power Wiring Sequence Warning	135
	DC Power Wiring Terminations Warning	136
	SRX240 Services Gateway Agency Approvals	138
	SRX240 Services Gateway Compliance Statements for EMC Requirements . . .	139
	Canada	139
	European Community	139
	Israel	139
	Japan	139
	United States	140
	SRX240 Services Gateway (DC Power Supply Model) Compliance Statements for Network Equipment Building System (NEBS)	140
	SRX240 Services Gateway Compliance Statements for Environmental Requirements	140
	SRX240 Services Gateway Compliance Statements for Acoustic Noise	141
Appendix B	SRX240 Services Gateway Power Guidelines, Requirements, and Specifications	143
	SRX240 Services Gateway Site Electrical Wiring Guidelines	143
	SRX240 Services Gateway AC Power Specifications and Requirements	145
	AC Power Requirement Specifications	145
	AC Power Cord Specifications	145
	SRX240 Services Gateway DC Power Specifications and Requirements	146
	DC Power System Electrical Specifications	146
	DC Power Cable Specifications	146
	SRX240 Services Gateway Grounding Specifications	147
Appendix C	SRX240 Services Gateway Interface Cable Specifications and Connector Pinouts	149
	Interface Cable and Wire Specifications for the SRX240 Services Gateway	149
	RJ-45 Connector Pinouts for the SRX240 Services Gateway Ethernet Port	149
	RJ-45 Connector Pinouts for the SRX240 Services Gateway Console Port	151
Appendix D	Contacting Customer Support and Returning the SRX240 Services Gateway Hardware	153
	Return Procedure for the SRX240 Services Gateway	153
	Locating SRX240 Services Gateway Component Serial Number and Agency Labels	154
	Listing the SRX240 Services Gateway and Component Details with the CLI	154
	SRX240 Services Gateway Chassis Serial Number and Agency Labels	155
	SRX240 Services Gateway Mini-Physical Interface Module Serial Number Label	155
	Contacting Customer Support to Obtain Return Materials Authorization	155
	Information You Might Need to Supply to Juniper Networks Technical Assistance Center	156
	Juniper Networks Technical Assistance Center	156
	Packing the SRX240 Services Gateway and Components for Shipment	156
	Packing the Services Gateway	157
	Packing the Components for Shipment	157

Part 5

Index

Index 161

About This Guide

- [Objectives on page ix](#)
- [Audience on page ix](#)
- [Documentation Conventions on page ix](#)
- [SRX Series Documentation and Release Notes on page xi](#)
- [Obtaining Documentation on page xii](#)
- [Documentation Feedback on page xii](#)
- [Requesting Technical Support on page xii](#)

Objectives

This guide describes hardware components and installation, basic configuration, and basic troubleshooting procedures for the Juniper Networks SRX240 Services Gateway. It explains how to prepare your site for services gateway installation, unpack and install the hardware, power on the services gateway, perform initial software configuration, and perform routine maintenance. After completing the installation and basic configuration procedures covered in this guide, see the Junos OS configuration guides for information about further Junos OS configuration.

Audience

This guide is designed for network administrators who are installing and maintaining a Juniper Networks SRX240 Services Gateway or preparing a site for device installation. To use this guide, you need a broad understanding of networks in general and the Internet in particular, networking principles, and network configuration. Any detailed discussion of these concepts is beyond the scope of this guide.

Documentation Conventions

[Table 1 on page x](#) defines the notice icons used in this guide.

Table 1: Notice Icons







Icon	Meaning	Description
	Informational note	Indicates important features or instructions.
	Caution	Indicates a situation that might result in loss of data or hardware damage.
	Warning	Alerts you to the risk of personal injury or death.
	Laser warning	Alerts you to the risk of personal injury from a laser.
	Tip	Indicates helpful information.
	Best practice	Alerts you to a recommended use or implementation.

Table 2 on page x defines the text and syntax conventions used in this guide.

Table 2: Text and Syntax Conventions

Convention	Description	Examples
Bold text like this	Represents text that you type.	To enter configuration mode, type the configure command: user@host> configure
Fixed-width text like this	Represents output that appears on the terminal screen.	user@host> show chassis alarms No alarms currently active
<i>Italic text like this</i>	<ul style="list-style-type: none"> Introduces or emphasizes important new terms. Identifies guide names. Identifies RFC and Internet draft titles. 	<ul style="list-style-type: none"> A policy <i>term</i> is a named structure that defines match conditions and actions. <i>Junos OS CLI User Guide</i> RFC 1997, <i>BGP Communities Attribute</i>
<i>Italic text like this</i>	Represents variables (options for which you substitute a value) in commands or configuration statements.	Configure the machine's domain name: [edit] root@# set system domain-name <i>domain-name</i>

Table 2: Text and Syntax Conventions (*continued*)

Convention	Description	Examples
Text like this	Represents names of configuration statements, commands, files, and directories; configuration hierarchy levels; or labels on routing platform components.	<ul style="list-style-type: none"> To configure a stub area, include the stub statement at the [edit protocols ospf area area-id] hierarchy level. The console port is labeled CONSOLE.
< > (angle brackets)	Encloses optional keywords or variables.	stub <default-metric <i>metric</i> >;
(pipe symbol)	Indicates a choice between the mutually exclusive keywords or variables on either side of the symbol. The set of choices is often enclosed in parentheses for clarity.	broadcast multicast (string1 string2 string3)
# (pound sign)	Indicates a comment specified on the same line as the configuration statement to which it applies.	rsvp { # Required for dynamic MPLS only
[] (square brackets)	Encloses a variable for which you can substitute one or more values.	community name members [community-ids]
Indentation and braces ({ })	Identifies a level in the configuration hierarchy.	[edit] routing-options { static { route default { nexthop <i>address</i> ; retain; } } }
;(semicolon)	Identifies a leaf statement at a configuration hierarchy level.	
GUI Conventions		
Bold text like this	Represents graphical user interface (GUI) items you click or select.	<ul style="list-style-type: none"> In the Logical Interfaces box, select All Interfaces. To cancel the configuration, click Cancel.
> (bold right angle bracket)	Separates levels in a hierarchy of menu selections.	In the configuration editor hierarchy, select Protocols>Ospf .

SRX Series Documentation and Release Notes

For a list of related SRX Series documentation, see <http://www.juniper.net/techpubs/hardware/srx-series-main.html>.

If the information in the latest *SRX Series Release Notes* differs from the information in the documentation, follow the *SRX Series Release Notes*.

Obtaining Documentation

To obtain the most current version of all Juniper Networks technical documentation, see the products documentation page on the Juniper Networks website at <http://www.juniper.net/techpubs>.

To order printed copies of this guide and other Juniper Networks technical documents, contact your sales representative.

Copies of the Management Information Bases (MIBs) available in a software release are included on the documentation CDs and at <http://www.juniper.net>.

Documentation Feedback

We encourage you to provide feedback, comments, and suggestions so that we can improve the documentation. You can send your comments to techpubs-comments@juniper.net, or fill out the documentation feedback form at <http://www.juniper.net/techpubs/docbug/docbugreport.html>. If you are using e-mail, be sure to include the following information with your comments:

- Document Name
- Document part number
- Page number
- Software release version (not required for *Network Operations Guides [NOGs]*)

Requesting Technical Support

Technical product support is available through the Juniper Networks Technical Assistance Center (JTAC). If you are a customer with an active J-Care or JNASC support contract, or are covered under warranty, and need postsales technical support, you can access our tools and resources online or open a case with JTAC.

- JTAC policies—For a complete understanding of our JTAC procedures and policies, review the *JTAC User Guide* located at <http://www.juniper.net/us/en/local/pdf/resource-guides/7100059-en.pdf>.
- Product warranties—For product warranty information, visit <http://www.juniper.net/support/warranty/>.
- JTAC Hours of Operation —The JTAC centers have resources available 24 hours a day, 7 days a week, 365 days a year.

Self-Help Online Tools and Resources

For quick and easy problem resolution, Juniper Networks has designed an online self-service portal called the Customer Support Center (CSC) that provides you with the following features:

- Find CSC offerings: <http://www.juniper.net/customers/support/>
- Find product documentation: <http://www.juniper.net/techpubs/>
- Find solutions and answer questions using our Knowledge Base: <http://kb.juniper.net/>
- Download the latest versions of software and review release notes: <http://www.juniper.net/customers/csc/software/>
- Search technical bulletins for relevant hardware and software notifications: <http://kb.juniper.net/InfoCenter/>
- Join and participate in the Juniper Networks Community Forum: <http://www.juniper.net/company/communities/>
- Open a case online in the CSC Case Management tool: <http://www.juniper.net/cm/>

To verify service entitlement by product serial number, use our Serial Number Entitlement (SNE) Tool: <https://tools.juniper.net/SerialNumberEntitlementSearch/>

Opening a Case with JTAC

You can open a case with JTAC on the Web or by telephone.

- Use the Case Management tool in the CSC at <http://www.juniper.net/cm/>.
- Call 1-888-314-JTAC (1-888-314-5822 toll-free in the USA, Canada, and Mexico).

For international or direct-dial options in countries without toll-free numbers, visit us at <http://www.juniper.net/support/requesting-support.html>

PART 1

SRX240 Services Gateway Overview

- [Introduction to the SRX240 Services Gateway on page 3](#)
- [SRX240 Services Gateway Hardware Components and Specifications on page 7](#)
- [SRX240 Services Gateway Mini-Physical Interface Modules on page 23](#)
- [SRX240 Services Gateway Power over Ethernet Support on page 25](#)

CHAPTER 1

Introduction to the SRX240 Services Gateway

This chapter includes the following topics:

- [SRX240 Services Gateway Description on page 3](#)
- [SRX240 Services Gateway Models on page 4](#)
- [SRX240 Services Gateway Hardware Features on page 5](#)

SRX240 Services Gateway Description

The Juniper Networks SRX240 Services Gateway offers complete functionality and flexibility for delivering secure, reliable data over IP, and provides multiple interfaces that support WAN and LAN connectivity and Power over Ethernet (PoE).

The SRX240 Services Gateway provides IP Security (IPsec), virtual private network (VPN), and firewall services for small and medium-sized companies and enterprise branch and remote offices. Additional security features include Unified Threat Management (UTM), which consists of IPS antispam, antivirus, and Web filtering.

The SRX240 Services Gateway runs the Juniper Networks Junos operating system (Junos OS).

The SRX240 Services Gateway has a modular 1U chassis that fits a 19-inch rack with a depth of approximately 17.5 in. (44.5 cm).

[Figure 1 on page 3](#) shows the SRX240 Services Gateway.

Figure 1: SRX240 Services Gateway

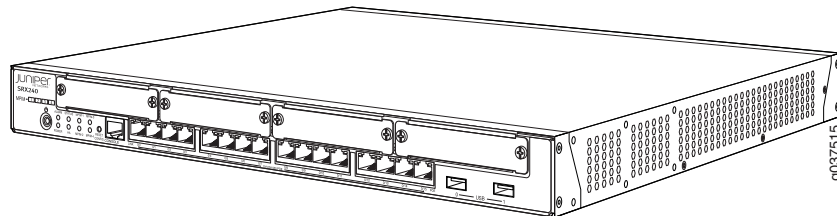

For information about SRX240 Services Gateway software features and licenses, see the following guides:

- [Initial Configuration for Security Devices](#)
- [Monitoring and Troubleshooting for Security Devices](#)

Related Documentation

- [SRX240 Services Gateway Chassis on page 7](#)

SRX240 Services Gateway Models

Table 3 on page 4 lists the SRX240 Services Gateway models.

Table 3: SRX240 Services Gateway Models

Model Name	Device Type
SRX240B	512 MB RAM, 1 GB flash memory with AC power supply
SRX240B2	1 GB RAM, 2 GB flash memory with AC power supply
SRX240H	1 GB RAM, 1 GB flash memory with AC power supply
SRX240H2	2 GB RAM, 2 GB flash memory with AC power supply
SRX240H-TAA	1 GB RAM, 1 GB flash memory with AC power supply (TAA compliant)
SRX240H2-TAA	2 GB RAM, 2 GB flash memory with AC power supply (TAA compliant)
SRX240H-DC	1 GB RAM, 1 GB flash memory with DC power supply
SRX240H2-DC	2 GB RAM, 2 GB flash memory with DC power supply
SRX240H-POE	1 GB RAM, 1 GB flash memory and Power over Ethernet (PoE) with AC power supply
SRX240H2-POE	2 GB RAM, 2 GB flash memory and Power over Ethernet (PoE) with AC power supply
SRX240H-POE-TAA	1 GB RAM, 1 GB flash memory and Power over Ethernet (PoE) with AC power supply (TAA compliant)
SRX240H2-POE-TAA	2 GB RAM, 2 GB flash memory and Power over Ethernet (PoE) with AC power supply (TAA compliant)

All models run Junos OS.

Related Documentation

- [SRX240 Services Gateway Description on page 3](#)
- [SRX240 Services Gateway Hardware Features on page 5](#)

- [SRX240 Services Gateway Chassis on page 7](#)

SRX240 Services Gateway Hardware Features

Table 4 on page 5 lists the hardware features supported on various models of the SRX240 Services Gateway.

Table 4: SRX240 Services Gateway Hardware Features

Features	SRX240 Services Gateway with AC Power Supply and No PoE Support	SRX240 Services Gateway with AC Power Supply and PoE Support	SRX240 Services Gateway with DC Power Supply
DDR memory	<ul style="list-style-type: none"> • For SRX240B: 512 MB • For SRX240B2: 1 GB • For SRX240H: 1 GB • For SRX240H2: 2 GB • For SRX240H-TAA: 1 GB • For SRX240H2-TAA: 2 GB 	<ul style="list-style-type: none"> • For SRX240H-POE: 1 GB • For SRX240H2-POE: 2 GB • For SRX240H-POE-TAA: 1 GB • For SRX240H2-POE-TAA: 2 GB 	<ul style="list-style-type: none"> • For SRX240H-DC: 1 GB • For SRX240H2-DC: 2 GB
PoE support	No	Yes	No
Power supply rating	150 watts	360 watts	190 watts
Input voltage	100 to 240 VAC	100 to 240 VAC	-48 VDC Operating range: -40.5 V to -72 V
Gigabit Ethernet ports	16	16	16
Console ports	1	1	1
Universal Serial Bus (USB) ports	2	2	2
Mini-PIM slots	4	4	4
LEDs	Status, Alarm, HA, Power, Mini-PIMs, and Port (TX/RX/Link and PoE)	Status, Alarm, HA, Power, Mini-PIMs, and Port (TX/RX/Link and PoE)	Status, Alarm, HA, Power, Mini-PIMs, Port (TX/RX/Link and PoE), DC power feed LEDs.

NOTE: The PoE LED is enabled only on the PoE variant of the SRX240 Services Gateway.

Table 4: SRX240 Services Gateway Hardware Features (*continued*)

Features	SRX240 Services Gateway with AC Power Supply and No PoE Support	SRX240 Services Gateway with AC Power Supply and PoE Support	SRX240 Services Gateway with DC Power Supply
Internal flash	<ul style="list-style-type: none"> For SRX240B: 1 GB For SRX240B2: 2 GB For SRX240H: 1 GB For SRX240H2: 2 GB For SRX240H-TAA: 1 GB For SRX240H2-TAA: 2 GB 	<ul style="list-style-type: none"> For SRX240H-POE: 1 GB For SRX240H2-POE: 2 GB For SRX240H-POE-TAA: 1 GB For SRX240H2-POE-TAA: 2 GB 	<ul style="list-style-type: none"> For SRX240H-DC: 1 GB For SRX240H2-DC: 2 GB
Fans	6	6	6
Air filters	One (Separately orderable)	None	One
NEBS-compliant	No	No	Yes



NOTE: An air filter is not shipped with the SRX240 Services Gateway with AC power supply models. To meet NEBS requirements, you must order the air filter separately and install it. Contact your Juniper Networks customer service representative for more information.

For more details about the chassis specification, see “[SRX240 Services Gateway Chassis](#)” on page 7.

Related Documentation

- [SRX240 Services Gateway Description on page 3](#)
- [SRX240 Services Gateway Chassis on page 7](#)

CHAPTER 2

SRX240 Services Gateway Hardware Components and Specifications

This chapter includes the following topics:

- SRX240 Services Gateway Chassis on page 7
- SRX240 Services Gateway Front Panel and Back Panel Views on page 9
- SRX240 Services Gateway Built-In Interfaces on page 12
- SRX240 Services Gateway LEDs on page 14
- SRX240 Services Gateway Boot Devices and Dual-Root Partitioning Scheme on page 18
- SRX240 Services Gateway Power Supply on page 20
- SRX240 Services Gateway Cooling System on page 21
- SRX240 Services Gateway Air Filter on page 21

SRX240 Services Gateway Chassis

Figure 1 on page 3 shows the SRX240 Services Gateway chassis.

Figure 2: SRX240 Services Gateway

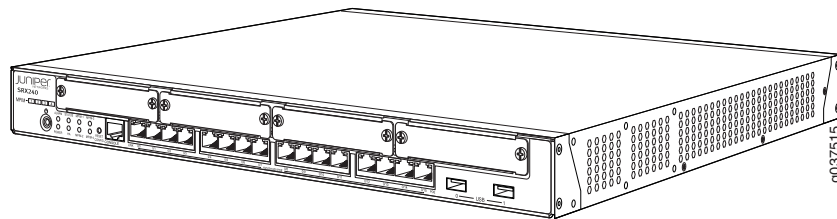

Table 5 on page 7 provides information about the physical specifications for the services gateway.

Table 5: Physical Specifications for the SRX240 Services Gateway

Specification	Value
Chassis height	1 unit (U)
Chassis width	17.5 in. (44.5 cm)

Table 5: Physical Specifications for the SRX240 Services Gateway (continued)

Specification	Value
Chassis depth	15 in. (38.1 cm)
Chassis weight	<ul style="list-style-type: none"> SRX240 Services Gateway with AC power supply and no PoE support models: 11.24 lb. (5.1 kg) SRX240 Services Gateway with AC power supply and PoE support models: 12.34 lb. (5.6 kg) SRX240 Services Gateway with DC power supply models: 12.56 lb. (5.7 kg)
Average Power consumption	<ul style="list-style-type: none"> SRX240 Services Gateway with AC power supply and no PoE support models: 74 watts SRX240 Services Gateway with AC power supply and PoE support: 86 watts (excluding PoE load) SRX240 Services Gateway with DC power supply models: 72 watts
Altitude	No performance degradation at upto 10,000 ft (3048 m)
Relative humidity	5% to 90%, noncondensing
Temperature	<p>Normal operation ensured in temperature range 32°F (0°C) through 104°F (40°C)</p> <p>Nonoperating storage temperature in shipping container: -40°F (-40°C) to 158°F (70°C)</p>
Seismic	Designed to meet Telcordia Technologies Zone 4 earthquake requirements
Maximum thermal output	<ul style="list-style-type: none"> SRX240 Services Gateway with AC power supply and no PoE support models: 427 BTU/hour SRX240 Services Gateway with AC power supply and PoE support models: 560 BTU/hour (Excluding PoE load) SRX240 Services Gateway with DC power supply models: 409 BTU/hour <p>NOTE: These specifications are estimates and subject to change.</p>
Noise level	Less than 70 dB(A) as per EN ISO 7779



NOTE: Before removing or installing components of a functioning services gateway, attach an electrostatic discharge (ESD) strap to an ESD point and fasten the other end of the strap around your bare wrist. Failure to use an ESD strap could result in damage to the services gateway.

Related Documentation

- [SRX240 Services Gateway Description on page 3](#)

- [SRX240 Services Gateway Hardware Features on page 5](#)
- [SRX240 Services Gateway Front Panel and Back Panel Views on page 9](#)
- [SRX240 Services Gateway Built-In Interfaces on page 12](#)
- [SRX240 Services Gateway LEDs on page 14](#)
- [SRX240 Services Gateway Power Supply on page 20](#)
- [SRX240 Services Gateway Cooling System on page 21](#)

SRX240 Services Gateway Front Panel and Back Panel Views

This topic describes the front panel and back panel of the SRX240 Services Gateway models. This topic includes the following sections:

- [SRX240 Services Gateway Front Panel on page 9](#)
- [SRX240 Services Gateway Back Panel \(AC power supply models\) on page 11](#)
- [SRX240 Services Gateway Back Panel \(DC Power Supply Model\) on page 11](#)

SRX240 Services Gateway Front Panel

Figure 3 on page 9 shows the front panel of an SRX240 Services Gateway.

Figure 3: SRX240 Services Gateway Front Panel (with AC Power Supply Model, and with DC Power Supply Models)

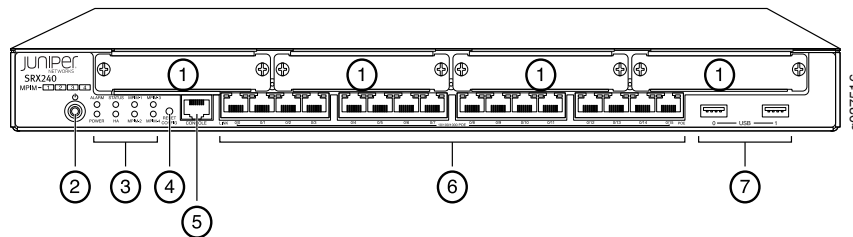

Table 6 on page 9 lists the front panel components of the services gateway.

Table 6: SRX240 Services Gateway Front Panel

Number	Component
1	Mini-PIM slots
2	Power button
3	LEDs: Status, Power, Mini-PIM, Alarm, HA
4	RESET CONFIG button
5	Console port
6	Gigabit Ethernet ports

Table 6: SRX240 Services Gateway Front Panel (continued)

Number	Component
7	Universal Serial Bus (USB) ports

For more information on the front panel components, see the following topics:

- [SRX240 Services Gateway Built-In Interfaces on page 12](#)
- [SRX240 Services Gateway LEDs on page 14](#)
- [SRX240 Services Gateway Boot Devices and Dual-Root Partitioning Scheme on page 18](#)

SRX240 Services Gateway Back Panel (AC power supply models)

Figure 4 on page 11 shows the back panel of the SRX240 Services Gateway AC power supply models.

Figure 4: SRX240 Services Gateway Back Panel (with AC Power Supply Models)

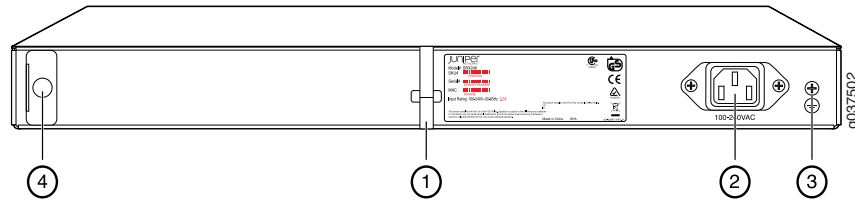

Table 7 on page 11 lists the back panel components of the SRX240 Services Gateway AC power supply models.

Table 7: SRX240 Services Gateway Back Panel AC Power Supply Models

Number	Component
1	Cable tie holder
2	Power supply point
3	Grounding point
4	Air filter slot



NOTE: The air filter is shipped with SRX240 Services Gateways with DC power supply models only.

You can order the air filter separately for the SRX240 Services Gateway with AC power supply models. Contact your Juniper Networks customer service representative for more information.

SRX240 Services Gateway Back Panel (DC Power Supply Model)

Figure 5 on page 11 shows the back panel of an SRX240 Services Gateway with DC power supply models.

Figure 5: SRX240 Services Gateway DC Power Supply Model

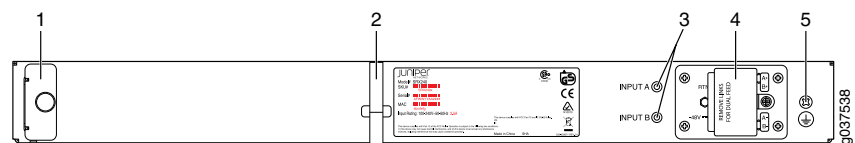

Table 8 on page 12 lists the back panel components of the SRX240 Services Gateway DC power supply models.

Table 8: SRX240 Services Gateway Back Panel DC power supply models

Number	Component
1	Air filter slot
2	Cable tie holder
3	DC power feed LEDs
4	DC power feed
5	Grounding point

Related Documentation

- [SRX240 Services Gateway Hardware Features on page 5](#)
- [SRX240 Services Gateway Chassis on page 7](#)
- [SRX240 Services Gateway Built-In Interfaces on page 12](#)
- [SRX240 Services Gateway LEDs on page 14](#)
- [SRX240 Services Gateway Boot Devices and Dual-Root Partitioning Scheme on page 18](#)
- [SRX240 Services Gateway Power Supply on page 20](#)
- [SRX240 Services Gateway Cooling System on page 21](#)

SRX240 Services Gateway Built-In Interfaces

Table 9 on page 12 describes the built-in interface ports on the SRX240 Services Gateway.

Table 9: SRX240 Services Gateway Built-In Interfaces

Interface Type	Description	Usage
Gigabit Ethernet	<ul style="list-style-type: none"> • 16 ports, labeled 0/0 through 0/15, built into the chassis front panel • Provide link speeds of 10/100/1000 Mbps • Operate in full-duplex and half-duplex modes <p>NOTE: On the PoE models of the SRX240 Services Gateway, all 16 Gigabit Ethernet ports support PoE.</p>	Function as front-end network ports and provide LAN and WAN connectivity to hubs, switches, local servers, and workstations.

Table 9: SRX240 Services Gateway Built-In Interfaces (*continued*)

Interface Type	Description	Usage
Universal Serial Bus (USB)	<ul style="list-style-type: none"> Two ports labeled, usb 0 and usb 1, built into the chassis front panel Function in the following modes: <ul style="list-style-type: none"> Full speed High speed Compliant with USB revision 2.0 	<ul style="list-style-type: none"> Support a USB storage device that functions as a secondary boot device in case of internal flash failure on startup. <p>NOTE: To use USB to boot your services gateway, you must install and configure the USB storage device on the USB port to use it as a secondary boot device. Additionally, the USB storage device must have Junos OS installed.</p> <ul style="list-style-type: none"> Provide the USB interfaces that are used to communicate with the various types of Juniper Networks-supported USB storage devices. <p>Contact a customer service representative for more information.</p>
Console	<ul style="list-style-type: none"> One port built into the chassis front panel Uses an RJ-45 serial cable connector Supports the RS-232 (EIA-232) standard 	<ul style="list-style-type: none"> Functions as a management port using which you can log in to the services gateway directly. Provides the interface to configure the services gateway using the CLI.
Mini-PIM slots	<ul style="list-style-type: none"> Four slots built into the chassis front panel Mini-PIMs can be plugged directly into the slots 	<p>Provide LAN and WAN functionality along with connectivity to various media types.</p> <p>For more information about Mini-PIMs, see the SRX Series Services Gateways for the Branch Physical Interface Modules Hardware Guide.</p>



NOTE: We strongly recommend that only transceivers provided by Juniper Networks be used on an SRX240 Services Gateway. We cannot guarantee that the interface module will operate correctly if third-party transceivers are used. Please contact Juniper Networks for the correct transceiver part number for your device.

Related Documentation

- [SRX240 Services Gateway Chassis on page 7](#)
- [SRX240 Services Gateway Front Panel and Back Panel Views on page 9](#)
- [SRX240 Services Gateway LEDs on page 14](#)
- [SRX240 Services Gateway Boot Devices and Dual-Root Partitioning Scheme on page 18](#)
- [SRX240 Services Gateway Power Supply on page 20](#)
- [SRX240 Services Gateway Cooling System on page 21](#)

SRX240 Services Gateway LEDs

This topic includes the following sections:

- Front Panel LEDs on page 14
- Ethernet Port LEDs on page 16
- DC Power Supply Feed LEDs (SRX240 Services Gateway DC Power Supply Model) on page 17

Front Panel LEDs

Figure 6 on page 14 shows the SRX240 Services Gateway front panel LEDs.

Figure 6: SRX240 Services Gateway Front Panel LEDs

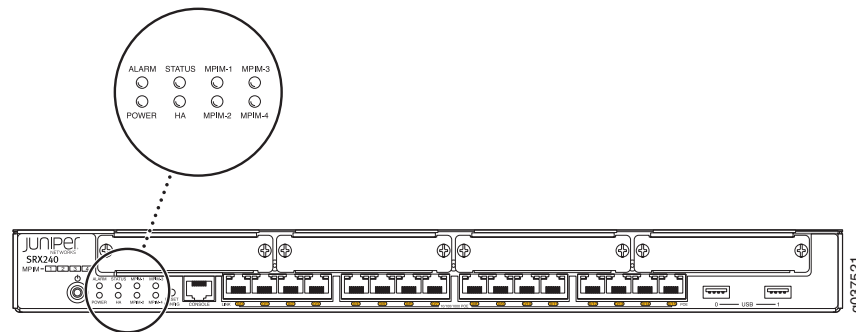

Table 10 on page 14 lists the LED indicators on the SRX240 Services Gateway front panel.

Table 10: SRX240 Services Gateway Front Panel Components

Component	Description	Usage
Status LED	<p>The Status LED has the following indicator colors:</p> <ul style="list-style-type: none"> • Green and steadily on indicates that the device is functioning normally. • Amber and steadily on indicates that the device is starting up. • Red and steadily on indicates that the device has failed. 	<p>The Status LED can be used to determine whether the device is starting up, is functioning normally, or has failed.</p>

Table 10: SRX240 Services Gateway Front Panel Components (*continued*)

Component	Description	Usage
Alarm LED	<p>The Alarm LED has the following indicator colors:</p> <ul style="list-style-type: none"> • Red and steadily on indicates a major alarm. • Amber and steadily on indicates a minor alarm. • Off indicates that the device is starting up. <p>NOTE: When the system is up and running, if the Alarm LED is off, it indicates that no alarms are present on the device.</p>	The Alarm LED can be used to gather information on major or minor alarms or to determine whether the device is functioning normally.
Power LED	<p>The Power LED has the following indicator colors:</p> <ul style="list-style-type: none"> • Green and steadily on indicates that the device is functioning normally. • Amber and steadily on indicates that the Power button has been pressed and quickly released. • Off indicates that the device is not receiving power. 	The Power LED can be used to determine whether the device is receiving power.
HA LED	<p>The HA LED has the following indicator colors:</p> <ul style="list-style-type: none"> • Green and steadily on indicates that all HA links are available. • Red and steadily on indicates that the HA links are not working as expected. • Amber and steadily on indicates that some HA links are not working as expected. • Off indicates that HA is not enabled. 	The HA LED can be used to determine whether the chassis clustering is enabled on the device.
Mini-PIM LED	<p>Each Mini-Physical Interface Module (Mini-PIM) LED has the following indicator colors:</p> <ul style="list-style-type: none"> • Green and steadily on indicates that the Mini-PIM is functioning normally. • Off indicates that the Mini-PIM is not present or not detected by the device. 	The Mini-PIM LED can be used to determine whether the Mini-PIM is present and detected by the device.

Ethernet Port LEDs

On the SRX240 Services Gateway, each Gigabit Ethernet port has the two LEDs as shown in Figure 7 on page 16.

Figure 7: SRX240 Services Gateway Port LEDs

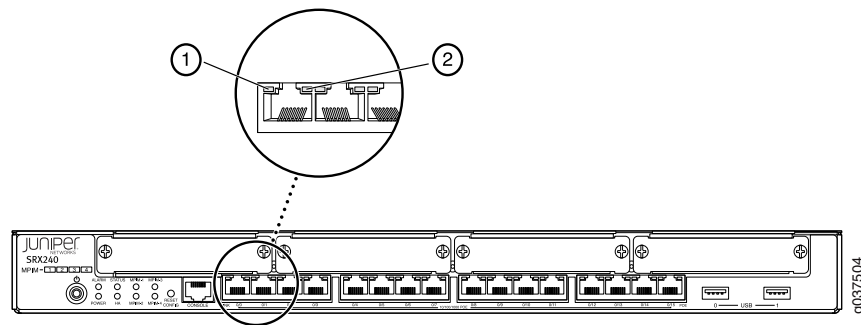

Table 11: SRX240 Services Gateway Port LEDs

Number	LED
1	TX/RX/Link LED
2	PoE (Power over Ethernet) LED



NOTE: The PoE LED is enabled only on the PoE variant of the SRX240 Services Gateway. For non-PoE services gateways, the PoE LED remains off.

Table 12 on page 16 describes the Ethernet port LEDs.

Table 12: SRX240 Services Gateway Ethernet Port LEDs

Function	Color	State	Description
TX/RX/Link	Green	Blinking	Link is active. Data communication is taking place.
		Steady	Link is active. No data communication is taking place.
	Unlit	Off	Link is inactive.

Table 12: SRX240 Services Gateway Ethernet Port LEDs (*continued*)

Function	Color	State	Description
PoE Status	Green	Steady	PoE is activated and the connected power device is receiving power.
	Yellow	Steady	PoE is activated, but the connected power device is not receiving power (fault or not enough power).
	Unlit	Off	PoE is disabled or no device is drawing power.

DC Power Supply Feed LEDs (SRX240 Services Gateway DC Power Supply Model)

On the SRX240 Services Gateway with DC power supply models, the back panel includes two LEDs, which indicate the status of the DC power supply feed.

Figure 8 on page 17 shows the DC power supply feed LEDs on the SRX240 Services Gateway with DC power supply model.

Figure 8: DC Power Supply Feed LEDs

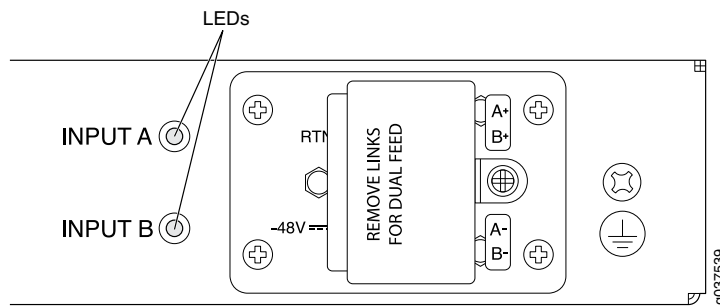

Table 13 on page 17 describes the DC power supply feed LEDs.

Table 13: DC Power Supply Feed LEDs

DC Input		DC Output	LED A	LED B
Input A	Input B			
Input is normal.	Input is normal.	No output ¹ .	Red	Red
		Output is normal.	Green	Green

Table 13: DC Power Supply Feed LEDs (*continued*)

DC Input		DC Output	LED A	LED B
Input A	Input B			
Input is connected but has failed because the power supply fuse has failed or input voltage is low.	Input is normal.	Output is normal.	Red (blinking)	Green
Input is normal.	Input is connected but has failed because the power supply fuse has failed or input voltage is low.	Output is normal.	Green	Red (blinking)
Input breaker open or no DC input connected.	Input is normal.	Output is normal.	Red (blinking)	Green
Input has failed.	Input has failed.	No output.	Red (blinking)	Red (blinking)
No input.	No input.	No output.	Off	Off

(1) No output because of output side failure or an open connection.

Related Documentation

- [SRX240 Services Gateway Chassis on page 7](#)
- [SRX240 Services Gateway Front Panel and Back Panel Views on page 9](#)
- [SRX240 Services Gateway Built-In Interfaces on page 12](#)
- [SRX240 Services Gateway Boot Devices and Dual-Root Partitioning Scheme on page 18](#)
- [SRX240 Services Gateway Power Supply on page 20](#)
- [SRX240 Services Gateway Cooling System on page 21](#)

SRX240 Services Gateway Boot Devices and Dual-Root Partitioning Scheme

This topic includes the following sections:

- [Boot Devices on page 18](#)
- [Dual-Root Partitioning Scheme on page 19](#)

Boot Devices

The SRX240 Services Gateway can boot from the following storage media (in the given order of priority):

- Internal NAND flash memory (default; always present)

- USB storage device (alternate)

Dual-Root Partitioning Scheme

Dual-root partitions allow SRX240 Services Gateways to remain functional if there is file system corruption and facilitate easy recovery of the corrupted file system.

The dual-root partitioning scheme keeps the primary and backup Junos OS images in two independently bootable root partitions. If the primary root partition becomes corrupted, the system will be able to boot from the backup Junos OS image located in the other root partition and remain fully functional.

When the services gateway powers up, it tries to boot Junos OS from the default storage media. If the services gateway fails to boot from the default storage media, it tries to boot from the alternate storage media. With the dual-root partitioning scheme, the services gateway first tries to boot Junos OS from the primary root partition and then from the backup root partition on the default storage media. The services gateway remains fully functional even if it boots Junos OS from the backup root partition of storage media.



NOTE: SRX Series Services Gateways that ship with Junos OS Release 10.0 or later are formatted for the dual-root partitioning scheme.

SRX240 Services Gateways that are running Junos OS Release 9.6 or earlier use the single-root partitioning scheme. While upgrading these services gateway to Junos OS Release 10.0 or later, you can choose to format the storage media with dual-root partitions (strongly recommended) or retain the existing single-root partitioning.

For instructions on upgrading to Junos OS Release 10.0 or later, see the following guides:

- [Initial Configuration for Security Devices](#)
- [Monitoring and Troubleshooting for Security Devices](#)

Related Documentation

- [SRX240 Services Gateway Chassis on page 7](#)
- [SRX240 Services Gateway Front Panel and Back Panel Views on page 9](#)
- [SRX240 Services Gateway Built-In Interfaces on page 12](#)
- [SRX240 Services Gateway LEDs on page 14](#)
- [SRX240 Services Gateway Power Supply on page 20](#)
- [SRX240 Services Gateway Cooling System on page 21](#)

SRX240 Services Gateway Power Supply

This topic includes the following sections:

- [AC Power Supply \(SRX240 Services Gateway\) on page 20](#)
- [DC Power Supply \(SRX240 Services Gateway with DC Power Supply Model\) on page 20](#)

AC Power Supply (SRX240 Services Gateway)

The SRX240 Services Gateway AC power supply models use a fixed, internal AC power supply. The power supply distributes the different output voltages to the device components according to their voltage requirements. The power supply is fixed in the chassis and is not field-replaceable.

The AC power supply has a single AC appliance inlet that requires a dedicated AC power feed.

DC Power Supply (SRX240 Services Gateway with DC Power Supply Model)

The SRX240 Services Gateway with DC power supply models have a fixed, internal DC power supply. The DC power supply available on the back panel of the chassis has dual redundant power feeds and provides full power redundancy in the device. The power supply is fixed in the chassis and is not field-replaceable.

The DC power supply feed has a terminal block that provides a single DC input (-48 VDC and return) and requires a dedicated 10 A (-48 VDC) circuit breaker. The DC power feed includes two LEDs that indicate the status of the power supply. For more details about the LEDs, see [“SRX240 Services Gateway LEDs” on page 14](#).



NOTE: Each power feed requires its own dedicated circuit breaker to be a fully redundant DC source.



NOTE: DC-powered devices are intended for installation only in a restricted access location.

Related Documentation

- [Connecting the SRX240 Services Gateway DC Power Supply Model to a DC Power Source on page 50](#)
- [SRX240 Services Gateway DC Power Specifications and Requirements on page 146](#)
- [DC Power Electrical Safety Guidelines and Warnings on page 132](#)
- [SRX240 Services Gateway Chassis on page 7](#)
- [SRX240 Services Gateway Front Panel and Back Panel Views on page 9](#)
- [SRX240 Services Gateway Built-In Interfaces on page 12](#)
- [SRX240 Services Gateway LEDs on page 14](#)

SRX240 Services Gateway Cooling System

SRX240 Services Gateways have six cooling fans.

The fans draw air from the right side of the chassis (when the chassis is viewed from the front) and exhaust the air at the left side of the chassis (when the chassis is viewed from the front) as shown in [Figure 9](#) on [page 21](#).

The airflow produced by these fans keeps all components within the acceptable temperature range.

Figure 9: Airflow Through the SRX240 Services Gateway Chassis

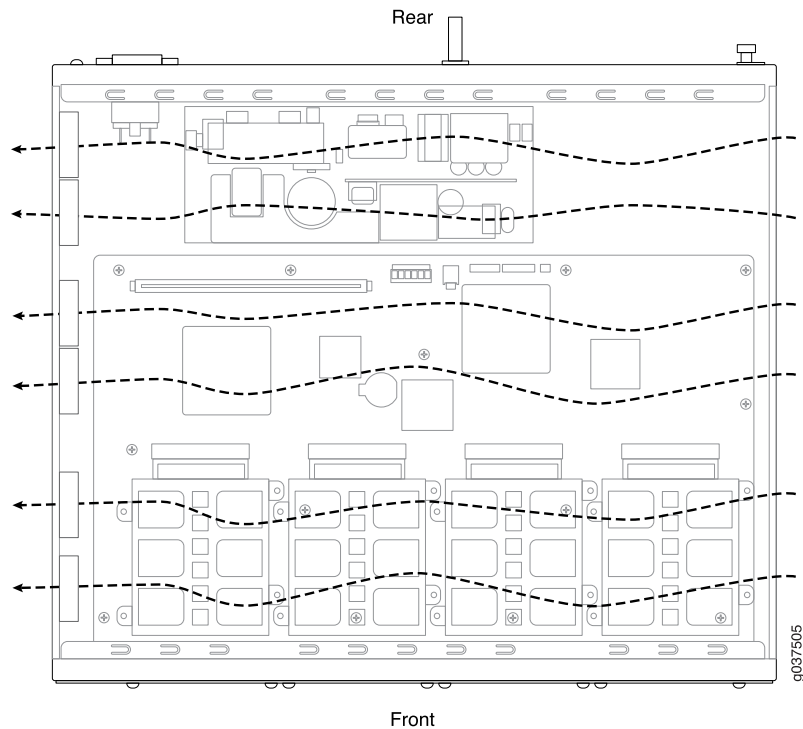

Related Documentation

- [SRX240 Services Gateway Chassis](#) on [page 7](#)
- [SRX240 Services Gateway Front Panel and Back Panel Views](#) on [page 9](#)
- [SRX240 Services Gateway Built-In Interfaces](#) on [page 12](#)
- [SRX240 Services Gateway LEDs](#) on [page 14](#)
- [SRX240 Services Gateway Boot Devices and Dual-Root Partitioning Scheme](#) on [page 18](#)
- [SRX240 Services Gateway Power Supply](#) on [page 20](#)

SRX240 Services Gateway Air Filter

The air filter for the SRX240 Services Gateway (both with AC power supply models and with DC power supply models) is hot-insertable and hot-removable. The air intake opening

is at the right side of the chassis (when the chassis is viewed from the front side). The air filter weighs approximately 0.2 lbs (0.09 kg). To ensure optimal operation, you must replace the air filter periodically (every six months).



NOTE: An air filter is not shipped with the SRX240 Services Gateway with AC power supply model. To meet NEBS requirements, you must order the air filter separately and install it. Contact your Juniper Networks customer service representative for more information.

**Related
Documentation**

- [Replacing the Air Filter on the SRX240 Services Gateway on page 90](#)
- [SRX240 Services Gateway Chassis on page 7](#)
- [SRX240 Services Gateway Front Panel and Back Panel Views on page 9](#)
- [SRX240 Services Gateway LEDs on page 14](#)
- [SRX240 Services Gateway Boot Devices and Dual-Root Partitioning Scheme on page 18](#)
- [SRX240 Services Gateway Power Supply on page 20](#)

CHAPTER 3

SRX240 Services Gateway Mini-Physical Interface Modules

This chapter includes the following topic:

- [Mini-Physical Interface Modules for the SRX240 Services Gateway on page 23](#)

Mini-Physical Interface Modules for the SRX240 Services Gateway

SRX240 Services Gateway support Mini-Physical Interface Modules (Mini-PIMs).

A Mini-PIM is a network interface card (NIC) that is installed on the services gateways to provide physical connections to a LAN or a WAN. The Mini-PIM receives incoming packets from the network and transmits outgoing packets to the network.

The Mini-PIMs supported on SRX240 Services Gateways are field-replaceable—you can remove and replace them. You can install a Mini-PIM in the Mini-PIM slots on the front panel of the services gateway chassis.



CAUTION: The Mini-PIMs for SRX240 Services Gateways are not hot-swappable. You must power off the services gateway before removing or installing Mini-PIMs.

For more information about supported Mini-PIMs, and on how to install and configure Mini-PIMs, refer to the [SRX Series Services Gateways for the Branch Physical Interface Modules Hardware Guide](#)

Related Documentation

- [SRX240 Services Gateway Chassis on page 7](#)
- [SRX240 Services Gateway Front Panel and Back Panel Views on page 9](#)
- [SRX240 Services Gateway LEDs on page 14](#)
- [SRX240 Services Gateway Built-In Interfaces on page 12](#)
- [SRX240 Services Gateway Cooling System on page 21](#)

CHAPTER 4

SRX240 Services Gateway Power over Ethernet Support

This chapter includes the following topics:

- [SRX240 Services Gateway Power over Ethernet Overview on page 25](#)
- [Configuring Power over Ethernet on the SRX240 Services Gateway on page 27](#)

SRX240 Services Gateway Power over Ethernet Overview

This topic includes the following sections:

- [Introduction on page 25](#)
- [PoE Classes and Power Ratings on page 26](#)

Introduction

Power over Ethernet (PoE) provides a device the capability to transmit both data and electric power over a copper Ethernet LAN cable.

The PoE-capable models of the SRX240 Services Gateway (see [“SRX240 Services Gateway Models” on page 4](#)) PoE on all Gigabit Ethernet ports. The PoE ports transfer electrical power and data, to remote devices over a standard twisted-pair cable in an Ethernet network. PoE ports allow you to plug in devices that require both network connectivity and electric power, such as wireless LAN access points, and VoIP telephones.

You can configure the services gateway to act as power sourcing equipment for devices connected to the PoE ports.

[Table 14 on page 25](#) lists the PoE specifications for SRX240 Services Gateway.

Table 14: SRX240 Services Gateway PoE Specifications

Power Management Schemes	Values
Supported standards	<ul style="list-style-type: none">• IEEE 802.3 AF• IEEE 802.3 AT (PoE+)• Legacy (pre-standards)

Table 14: SRX240 Services Gateway PoE Specifications (*continued*)

Power Management Schemes	Values
Supported ports	PoE is supported on all 16 Gigabit Ethernet ports (0/0 through 0/15; interfaces ge-0/0/0 through ge-0/0/15)
Total PoE power sourcing capacity	150 watts
Per port power limit	30 watts NOTE: Default value is 15.4 watts
Power management modes	<ul style="list-style-type: none"> • Static: Power allocated for each interface can be configured. • Class: Power allocated for interfaces is decided on the basis of class of powered device connected.

PoE Classes and Power Ratings

A powered device is classified on the basis of the maximum power that it draws across all input voltages and operational modes. When class-based power management mode is configured on the services gateway, power is allocated taking into account the maximum power ratings defined for the different classes of devices.

Table 15 on page 26 lists the classes and their power ratings as specified by the IEEE 802.3 AF standard.

Table 15: PoE Classes and Power Ratings

Class	Minimum Power Level Output from PoE Port
0	15.4 watts
1	4.0 watts
2	7.0 watts
3	15.4 watts
4	30.0 watts

Related Documentation

- [SRX240 Services Gateway Description on page 3](#)
- [SRX240 Services Gateway Chassis on page 7](#)
- [SRX240 Services Gateway Front Panel and Back Panel Views on page 9](#)
- [SRX240 Services Gateway Built-In Interfaces on page 12](#)
- [SRX240 Services Gateway LEDs on page 14](#)
- [Mini-Physical Interface Modules for the SRX240 Services Gateway on page 23](#)

Configuring Power over Ethernet on the SRX240 Services Gateway

To enable the PoE support on your SRX240 services gateway to work properly, you must configure the services gateway.

You can configure PoE using Junos OS CLI.

For more details on configuring the PoE, see the [Interfaces for Security Devices](#).

Related Documentation

- [SRX240 Services Gateway Power over Ethernet Overview on page 25](#)
- [SRX240 Services Gateway Description on page 3](#)
- [SRX240 Services Gateway Built-In Interfaces on page 12](#)
- [SRX240 Services Gateway LEDs on page 14](#)

PART 2

Setting Up the SRX240 Services Gateway

- [Preparing the Site for the SRX240 Services Gateway Installation on page 31](#)
- [Installation Overview for the SRX240 Services Gateway on page 37](#)
- [Required Tools and Parts for Installing and Maintaining the SRX240 Services Gateway on page 39](#)
- [Unpacking the SRX240 Services Gateway on page 41](#)
- [Installing the SRX240 Services Gateway on page 43](#)
- [Connecting, Grounding, and Powering On the SRX240 Services Gateway on page 49](#)
- [SRX240 Services Gateway Autoinstallation on page 61](#)
- [Connecting the SRX240 Services Gateway to Management Devices on page 63](#)
- [Performing Initial Software Configuration on the SRX240 Services Gateway on page 71](#)

CHAPTER 5

Preparing the Site for the SRX240 Services Gateway Installation

This chapter includes the following topics:

- [Site Preparation Checklist for the SRX240 Services Gateway on page 31](#)
- [General Site Guidelines for Installing the SRX240 Services Gateway on page 32](#)
- [SRX240 Services Gateway Rack Requirements on page 33](#)
- [Clearance Requirements for Airflow and Hardware Maintenance on the SRX240 Services Gateway on page 34](#)
- [SRX240 Services Gateway Electrical and Power Requirements on page 35](#)

Site Preparation Checklist for the SRX240 Services Gateway

The checklist in [Table 16 on page 31](#) summarizes the tasks you need to perform when preparing a site for installing the SRX240 Services Gateway.

Table 16: Site Preparation Checklist for Services Gateway Installation

Item or Task	Additional Information	Date and Notes
Environment		
Verify that environmental factors such as temperature and humidity do not exceed device tolerances.	"SRX240 Services Gateway Chassis" on page 7	
Power		
Measure distance between external power sources and device installation site.	"SRX240 Services Gateway Electrical and Power Requirements" on page 35	
Locate sites for connection of system grounding.	"SRX240 Services Gateway Grounding Specifications" on page 147	
Gather the AC power requirements.	"SRX240 Services Gateway AC Power Specifications and Requirements" on page 145	

Table 16: Site Preparation Checklist for Services Gateway Installation (continued)

Item or Task	Additional Information	Date and Notes
Gather the DC power requirements.	"SRX240 Services Gateway DC Power Specifications and Requirements" on page 146	
Rack Installation		
<ul style="list-style-type: none"> Verify that your rack meets the minimum requirements. Plan the rack location, including required space clearances. Secure the rack to the floor and the building structure. 	"SRX240 Services Gateway Rack Requirements" on page 33	
Cables		
<ul style="list-style-type: none"> Acquire cables and connectors. Choose the cable length as required by the distance between the hardware components being connected. Plan the cable routing and management. 	"Interface Cable and Wire Specifications for the SRX240 Services Gateway" on page 149	

Related Documentation

- [SRX240 Services Gateway Chassis on page 7](#)
- [SRX240 Services Gateway Site Electrical Wiring Guidelines on page 143](#)
- [SRX240 Services Gateway Rack Requirements on page 33](#)
- [Clearance Requirements for Airflow and Hardware Maintenance on the SRX240 Services Gateway on page 34](#)
- [Interface Cable and Wire Specifications for the SRX240 Services Gateway on page 149](#)
- [General Site Guidelines for Installing the SRX240 Services Gateway on page 32](#)

General Site Guidelines for Installing the SRX240 Services Gateway

The following precautions help you plan an acceptable operating environment for your SRX240 Services Gateway and avoid environmentally caused equipment failures:

- For the cooling system to function properly, the airflow around the chassis must be unrestricted. Allow sufficient clearance between the front and back of the chassis and adjacent equipment. Ensure that there is adequate circulation in the installation location.
- Follow the ESD procedures to avoid damaging the equipment. Static discharge can cause components to fail completely or intermittently over time.
- Ensure that the blank Mini-PIM panel is installed in the empty slot to prevent any interruption or reduction in the flow of air across internal components.



NOTE: Install the device only in restricted areas, such as dedicated equipment rooms and equipment closets, in accordance with Articles 110-16, 110-17, and 110-18 of the National Electrical Code, ANSI/NFPA 70.

Related Documentation

- [SRX240 Services Gateway Chassis on page 7](#)
- [SRX240 Services Gateway Site Electrical Wiring Guidelines on page 143](#)
- [SRX240 Services Gateway Rack Requirements on page 33](#)
- [Clearance Requirements for Airflow and Hardware Maintenance on the SRX240 Services Gateway on page 34](#)
- [Interface Cable and Wire Specifications for the SRX240 Services Gateway on page 149](#)

SRX240 Services Gateway Rack Requirements

The SRX240 Services Gateway can be installed in a rack. Many types of racks are acceptable, including front-mount racks and four-post (telco) racks.

[Table 17 on page 33](#) provides the details on rack size, clearance, and airflow requirements.

Table 17: Rack Requirements for the Services Gateway

Rack Requirements	Specifications
Rack Size	A 19 in. (48.3 cm) rack as defined in <i>Cabinets, Racks, Panels, and Associated Equipment</i> (document number EIA-310-D) published by the Electronics Industry Association (http://www.eia.org).
Rack Requirements	<ul style="list-style-type: none"> • The outer edges of the mounting brackets extend the width of either chassis to 19 in. (48.3 cm). • The front of the chassis extends approximately 0.5 in. (1.27 cm) beyond the mounting ears. • Maximum permissible ambient temperature when two devices are placed side by side in a 19 in. rack is 40° C.
Spacing of Mounting Bracket and Flange Holes	<ul style="list-style-type: none"> • The holes within each rack set are spaced at 1 U. The device can be mounted in any rack that provides holes or hole patterns spaced at 1-U [1.75 in. (4.5 cm)] increments. • The mounting brackets and front-mount flanges used to attach the chassis to a rack are designed to fasten to holes spaced at rack distances of 1 U (1.75 in.). • The mounting holes in the mounting brackets provided with the device are spaced 1.25 in. (3.2 cm) apart (top and bottom mounting hole).
Connecting to the Building Structure	Always secure the rack in which you are installing the services gateway to the structure of the building. If your geographical area is subject to earthquakes, bolt the rack to the floor. For maximum stability, also secure the rack to ceiling brackets.

- Related Documentation**
- [General Site Guidelines for Installing the SRX240 Services Gateway on page 32](#)
 - [Clearance Requirements for Airflow and Hardware Maintenance on the SRX240 Services Gateway on page 34](#)
 - [SRX240 Services Gateway Electrical and Power Requirements on page 35](#)

Clearance Requirements for Airflow and Hardware Maintenance on the SRX240 Services Gateway

When planning the installation site for the SRX240 Services Gateway, you need to allow sufficient clearance around the rack.

When planning the installation site for the services gateway, consider the following:

- For the cooling system to function properly, the airflow around the chassis must be unrestricted.
- For service personnel to remove and install hardware components, there must be adequate space at the front and back of the device.
- For the DC power supply model, ensure that you follow the NEBS recommendation—The NEBS GR-63 recommends that you allow at least 30 in. (72.6 cm) in front of the rack and 24 in. (61.0 cm) behind the rack.
- If you are mounting the device in a rack with other equipment, or if you are placing it on the desktop near other equipment, ensure that the exhaust from other equipment does not blow into the intake vents of the chassis.

[Table 18 on page 34](#) provides information on the clearance requirements for maintaining the optimum airflow and the distances for facilitating easy maintenance of the device.

Table 18: Clearance Requirements for the Services Gateway

Location	Recommended Clearance	Requirement for Clearance
Between front-mounting flange and rack or cabinet edge	2.5 in. (6.35 cm)	Space for cable management and organization
Between side of the chassis and any non-heat-producing surface such as a wall or cabinet side	2.5 in. (6.35 cm)	Space for the cooling system to function properly and to maintain unrestricted airflow around the chassis
Between side of the chassis and devices that have fans or blowers	2.5 in. (6.35 cm)	Space for the cooling system to function properly and to maintain unrestricted airflow around the chassis

- Related Documentation**
- [General Site Guidelines for Installing the SRX240 Services Gateway on page 32](#)
 - [SRX240 Services Gateway Rack Requirements on page 33](#)

- [SRX240 Services Gateway Electrical and Power Requirements on page 35](#)

[SRX240 Services Gateway Electrical and Power Requirements](#)

There are factors you must consider while planning the electrical wiring and power availability at your site. These factors include the following requirements:

- Power specifications and requirements for the device
- Electrical wiring guidelines for the device installation site
- Power, connection, and power cord specifications for the device
- Grounding guidelines and specifications for the device

Related Documentation

- [General Site Guidelines for Installing the SRX240 Services Gateway on page 32](#)
- [SRX240 Services Gateway Rack Requirements on page 33](#)
- [Clearance Requirements for Airflow and Hardware Maintenance on the SRX240 Services Gateway on page 34](#)

CHAPTER 6

Installation Overview for the SRX240 Services Gateway

This chapter includes the following topic:

- [Installation Overview for the SRX240 Services Gateway on page 37](#)

Installation Overview for the SRX240 Services Gateway

After you have prepared your installation site, you are ready to unpack and install the services gateway. It is important to proceed through the installation process as shown in [Table 19 on page 37](#).

Table 19: Installation Process Sequence for the SRX240 Services Gateway

Steps	Process	For More Information
1	Review the safety guidelines.	"SRX240 Services Gateway Safety Requirements, Warnings, and Guidelines" on page 43
2	Verify that you have prepared your site for the installation of the services gateway using the checklist.	"Site Preparation Checklist for the SRX240 Services Gateway" on page 31
3	Unpack the services gateway and verify that the parts are received.	"Unpacking the SRX240 Services Gateway" on page 41
4	Prepare the services gateway for installation.	"Preparing the SRX240 Services Gateway for Installation" on page 43
5	Install the services gateway.	"Installing the SRX240 Services Gateway" on page 44

Table 19: Installation Process Sequence for the SRX240 Services Gateway (continued)

Steps	Process	For More Information
6	Connect the power supply	<p>“Connecting the SRX240 Services Gateway to the AC Power Source” on page 49</p> <p>(For SRX240 Services Gateway with AC power supply models)</p> <hr/> <p>“Connecting the SRX240 Services Gateway DC Power Supply Model to a DC Power Source” on page 50</p> <p>(For SRX240 Services Gateway with DC power supply models)</p>
7	Connect cables to external devices.	“Connecting and Organizing Interface Cables to the SRX240 Services Gateway” on page 54
8	Connect the grounding cable.	“Grounding the SRX240 Services Gateway” on page 55
9	Power on the services gateway.	“Powering On and Powering Off the SRX240 Services Gateway” on page 57

Related Documentation

- [SRX240 Services Gateway Safety Requirements, Warnings, and Guidelines on page 43](#)
- [General Site Guidelines for Installing the SRX240 Services Gateway on page 32](#)
- [Unpacking the SRX240 Services Gateway on page 41](#)
- [Preparing the SRX240 Services Gateway for Installation on page 43](#)
- [Connecting and Organizing Interface Cables to the SRX240 Services Gateway on page 54](#)
- [Grounding the SRX240 Services Gateway on page 55](#)
- [Powering On and Powering Off the SRX240 Services Gateway on page 57](#)

CHAPTER 7

Required Tools and Parts for Installing and Maintaining the SRX240 Services Gateway

This chapter includes the following topic:

- [Required Tools and Parts for Installing and Maintaining the SRX240 Services Gateway on page 39](#)

Required Tools and Parts for Installing and Maintaining the SRX240 Services Gateway

[Table 20 on page 39](#) lists the tools and equipments required to install and maintain the SRX240 Services Gateway.

Table 20: Required Tools and Parts for Installing and Maintaining the SRX240 Services Gateway

Task	Tools and Parts	Related Topic
Installing the SRX240 Services Gateway	<ul style="list-style-type: none">• Phillips (+) screwdrivers, number-2 and number-3• Tie wrap	“Installing the SRX240 Services Gateway” on page 44
Connecting the SRX240 Services Gateway	Electrostatic discharge (ESD) grounding wrist strap	“Connecting the SRX240 Services Gateway to the AC Power Source” on page 49
Connecting the SRX240 Services Gateway to a DC power source	<ul style="list-style-type: none">• DC power source cables (12–14 AWG) with ring lug (Molex 190700067 or equivalent) (not provided)• Phillips (+) screwdriver, number 1	“Connecting the SRX240 Services Gateway DC Power Supply Model to a DC Power Source” on page 50
Grounding the SRX240 Services Gateway	Phillips (+) screwdrivers, numbers 1 and 2	“Grounding the SRX240 Services Gateway” on page 55

Table 20: Required Tools and Parts for Installing and Maintaining the SRX240 Services Gateway (*continued*)

Task	Tools and Parts	Related Topic
Replacing the air filter on the SRX240 Services Gateway (DC power supply model)	Electrostatic discharge (ESD) grounding wrist strap	"Replacing the Air Filter on the SRX240 Services Gateway" on page 90
Packing the SRX240 Services Gateway	<ul style="list-style-type: none"> Blank panels to cover empty slots Electrostatic bag or antistatic mat, for each component Electrostatic discharge (ESD) grounding wrist strap 	"Packing the SRX240 Services Gateway and Components for Shipment" on page 156

Related Documentation

- [Unpacking the SRX240 Services Gateway on page 41](#)
- [Installing the SRX240 Services Gateway on page 44](#)
- [Grounding the SRX240 Services Gateway on page 55](#)
- [Connecting the SRX240 Services Gateway to the AC Power Source on page 49](#)
- [Packing the SRX240 Services Gateway and Components for Shipment on page 156](#)

CHAPTER 8

Unpacking the SRX240 Services Gateway

This chapter includes the following topics:

- [Unpacking the SRX240 Services Gateway on page 41](#)
- [Verifying Parts Received with the SRX240 Services Gateway on page 41](#)

Unpacking the SRX240 Services Gateway

The SRX240 Services Gateway is shipped in a cardboard carton and secured with foam packing material. The carton also contains an accessory box and the *SRX240 Services Gateway Quick Start*.



NOTE: The services gateway is maximally protected inside the shipping crate. Do not unpack it until you are ready to begin installation.

To unpack the services gateway:

1. Open the box in which the device is shipped.
2. Verify the parts received as in the list provided in [Verifying Parts Received](#) topic. See [Related Topics](#).
3. Store the shipping box and packing material in case you need to return or move the device at a later time.

Related Documentation

- [Required Tools and Parts for Installing and Maintaining the SRX240 Services Gateway on page 39](#)
- [Verifying Parts Received with the SRX240 Services Gateway on page 41](#)
- [Preparing the SRX240 Services Gateway for Installation on page 43](#)

Verifying Parts Received with the SRX240 Services Gateway

The SRX240 Services Gateway shipment package contains a packing list that includes all parts and accessories available with the device. Check the parts in the shipment against the items on the packing list. The packing list specifies the part numbers and descriptions of each part in your order.



NOTE: If any part is missing, contact your Juniper Networks customer service representative.

A fully configured SRX240 Services Gateway contains the chassis with installed components, listed in [Table 21 on page 42](#) and an accessory box, which contains the parts listed in [Table 22 on page 42](#).



NOTE: The parts shipped with your device can vary depending on the configuration you ordered.

Table 21: Parts List for a Fully Configured SRX240 Services Gateway

Component	Quantity
Rack Mounting Kit	1
3-prong power cord [Not available for SRX240 Services Gateway with DC power supply models]	1
DB-9 to RJ-45 adapter, straight through, 7 feet	1

Table 22: Accessory Parts List for the SRX240 Services Gateway

Part	Quantity
Juniper Networks Product Warranty	1
End User License Agreement	1
SRX240 Services Gateway Quick Start	1
Security Products Safety Guide	1
Juniper Networks Compliance Form Letter	1
Product Registration	1

Related Documentation

- [Unpacking the SRX240 Services Gateway on page 41](#)
- [Preparing the SRX240 Services Gateway for Installation on page 43](#)
- [Installing the SRX240 Services Gateway on page 44](#)

Installing the SRX240 Services Gateway

This chapter includes the following topics:

- [SRX240 Services Gateway Safety Requirements, Warnings, and Guidelines on page 43](#)
- [Preparing the SRX240 Services Gateway for Installation on page 43](#)
- [Installing the SRX240 Services Gateway on page 44](#)
- [Replacing or Installing Mini-Physical Interface Modules in the SRX240 Services Gateway on page 47](#)

SRX240 Services Gateway Safety Requirements, Warnings, and Guidelines

To avoid harm to yourself or the device as you install and maintain it, follow the guidelines for working with and near electrical equipment, as well as the safety procedures for working with devices. For a discussion of how to make the installation site a safe environment along with a list of safety warnings, see Appendix A, Safety and Regulatory Compliance Information.



NOTE: Providing an exhaustive set of guidelines for working with electrical equipment is beyond the scope of this guide.

Related Documentation

- [Preparing the SRX240 Services Gateway for Installation on page 43](#)
- [Installing the SRX240 Services Gateway on page 44](#)

Preparing the SRX240 Services Gateway for Installation

You can mount an SRX240 Services Gateway in a rack. The services gateway can be mounted on four-post (telco) racks, enclosed cabinets, and open-frame racks.

Table 23: SRX240 Services Gateway Preinstallation Checklist

Task	Additional Information
Verify that the installation site meets the requirements.	"General Site Guidelines for Installing the SRX240 Services Gateway" on page 32

Table 23: SRX240 Services Gateway Preinstallation Checklist (*continued*)

Task	Additional Information
Remove the services gateway chassis from the shipping carton.	"Unpacking the SRX240 Services Gateway" on page 41
Verify the parts you have received.	"Verifying Parts Received with the SRX240 Services Gateway" on page 41

Related Documentation

- [General Site Guidelines for Installing the SRX240 Services Gateway on page 32](#)
- [Unpacking the SRX240 Services Gateway on page 41](#)
- [Verifying Parts Received with the SRX240 Services Gateway on page 41](#)
- [Installing the SRX240 Services Gateway on page 44](#)

Installing the SRX240 Services Gateway

You can front-mount or center-mount the SRX240 Services Gateway in a rack.



NOTE: If you are installing multiple devices in one rack, install the lowest one first and proceed upward in the rack.

To install the device in a rack:

1. Position a mounting bracket on each side of the chassis. You can position the brackets in:
 - Front-mount position as shown in [Figure 10 on page 45](#).
 - Center-mount position as shown in [Figure 11 on page 45](#).



NOTE: Positioning the brackets in the center offers greater stability.

Figure 10: Installing the SRX240 Services Gateway in a Rack (Front-Mount)

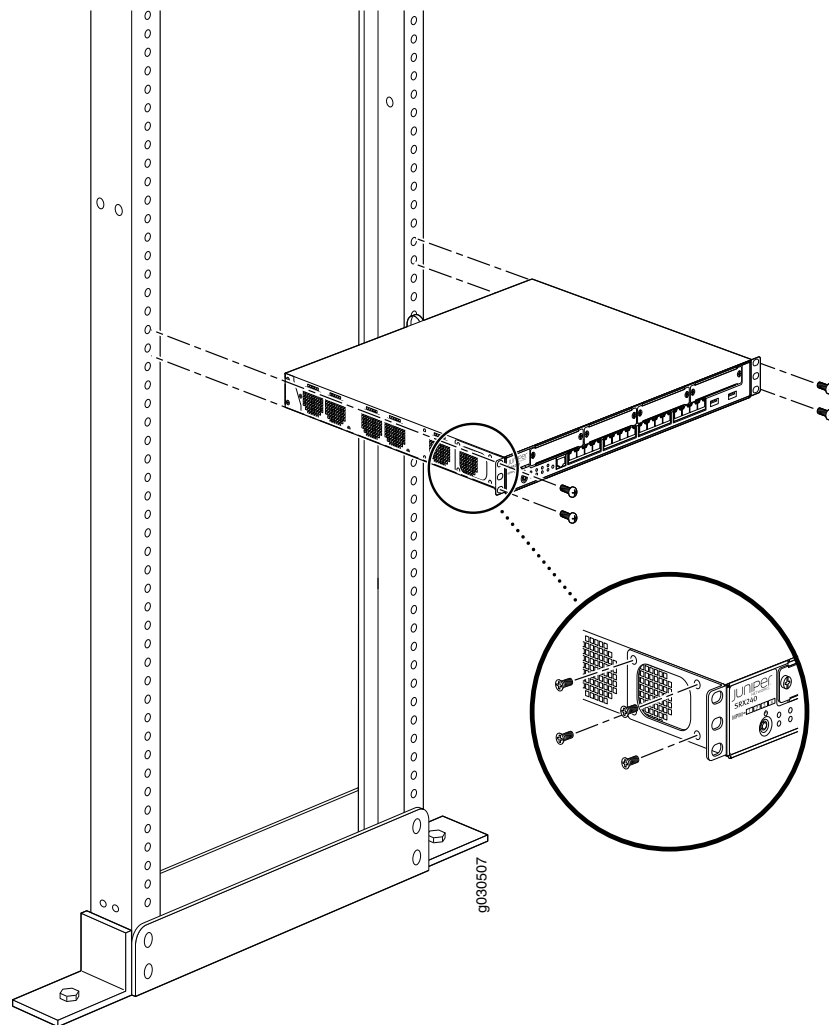
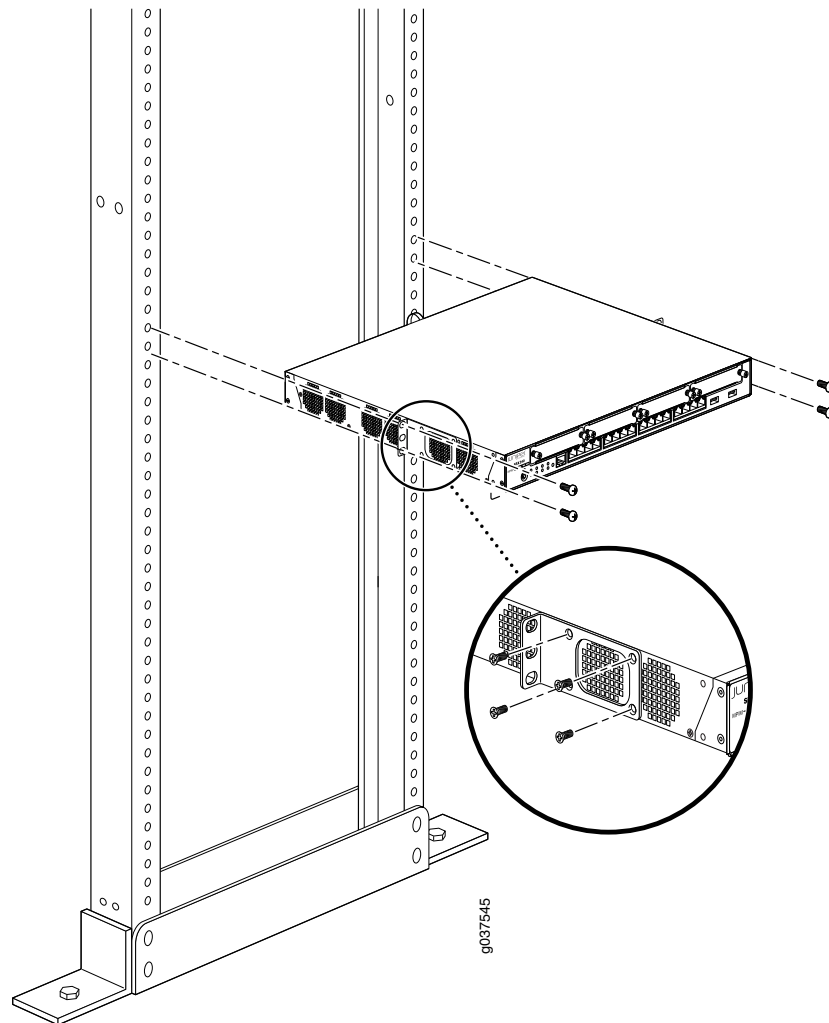

Figure 11: Installing the SRX240 Services Gateway in a Rack (Center-Mount)



2. Use a number-2 Phillips screwdriver to install the screws that secure the mounting brackets to the chassis.
3. Have one person grasp the sides of the device, lift it, and position it in the rack.
4. Align the bottom hole in each mounting bracket with a hole in each rack rail, making sure the chassis is level.
5. Have a second person install a mounting screw into each of the two aligned holes. Use a number-3 Phillips screwdriver to tighten the screws.
6. Install the second screw in each mounting bracket.
7. Verify that the mounting screws on one side of the rack are aligned with the mounting screws on the opposite side and that the device is level.

Related Documentation

- [Preparing the SRX240 Services Gateway for Installation on page 43](#)
- [Required Tools and Parts for Installing and Maintaining the SRX240 Services Gateway on page 39](#)

- [SRX240 Services Gateway Installation Safety Guidelines and Warnings on page 116](#)

Replacing or Installing Mini-Physical Interface Modules in the SRX240 Services Gateway

Mini-Physical Interface Modules (Mini-PIMs) are circuit boards that you can install in a device for enhanced functionality based on your requirements. They enable you to easily add or change physical interfaces on a device.

The Mini-Physical Interface Module (Mini-PIM) slot is covered with a blank faceplate to maintain proper airflow through the services gateway. Before installing the Mini-PIM, you must remove the faceplate.

See the [SRX Series Services Gateways for the Branch Physical Interface Modules Hardware Guide](#) for information about installing the Mini-PIMs.



NOTE: The Mini-PIMs available on the SRX240 Services Gateway are not hot-swappable. You need to power off the device before removing or installing Mini-PIMs.

Related Documentation

- [SRX240 Services Gateway Installation Safety Guidelines and Warnings on page 116](#)
- [Required Tools and Parts for Installing and Maintaining the SRX240 Services Gateway on page 39](#)
- [Installing the SRX240 Services Gateway on page 44](#)

CHAPTER 10

Connecting, Grounding, and Powering On the SRX240 Services Gateway

This chapter includes the following topics:

- Connecting the SRX240 Services Gateway to the AC Power Source on page 49
- Connecting the SRX240 Services Gateway DC Power Supply Model to a DC Power Source on page 50
- Connecting and Organizing Interface Cables to the SRX240 Services Gateway on page 54
- Grounding the SRX240 Services Gateway on page 55
- Powering On and Powering Off the SRX240 Services Gateway on page 57

Connecting the SRX240 Services Gateway to the AC Power Source

Figure 12 on page 49 shows how the SRX240 Services Gateway is connected to an AC power source.

Figure 12: SRX240 Services Gateway Power Supply Connection

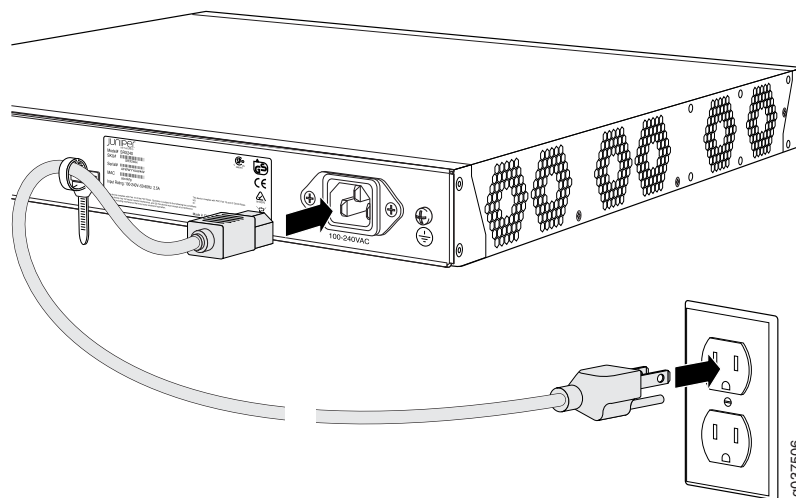

To connect the device to the power supply:

1. Attach an electrostatic discharge (ESD) grounding strap to your bare wrist, and connect the other end of the ESD strap to the ESD point on the rack.
2. Insert the appliance coupler end of a power cord into the appliance inlet on the power supply faceplate.
3. Insert the plug into an AC power source receptacle.



NOTE: The services gateway must be connected to earth ground during normal operation. The protective earthing terminal on the rear of the chassis is provided to connect the services gateway to ground.



CAUTION: We recommend using a surge protector for the power connection.



NOTE: Use the cable tie holder to secure the power cord on to the power supply point.



NOTE: We strongly recommend that you use only the 3-prong power cord supplied with your services gateway. If you are using a 2-prong power cord, then ensure that your services gateway is adequately grounded using the grounding point available on the back panel of the chassis.

Related Documentation

- [Installing the SRX240 Services Gateway on page 44](#)
- [Required Tools and Parts for Installing and Maintaining the SRX240 Services Gateway on page 39](#)
- [Connecting and Organizing Interface Cables to the SRX240 Services Gateway on page 54](#)
- [Grounding the SRX240 Services Gateway on page 55](#)
- [Powering On and Powering Off the SRX240 Services Gateway on page 57](#)

Connecting the SRX240 Services Gateway DC Power Supply Model to a DC Power Source



WARNING: DC-powered SRX240 Services Gateways are intended for installation only in a restricted access location.



WARNING: Before performing the following procedure, ensure that power is removed from the DC circuit. To ensure that all power is off, locate the circuit breaker on the panel board that services the DC circuit, switch the circuit breaker to the off position, and tape the switch handle of the circuit breaker in the off position.

Required tools and parts:

- DC power source cables (12–14 AWG) with ring lug (Molex 190700067 or equivalent) (not provided)
- Phillips (+) screwdriver, number 1

Before you begin:

- Ensure that you have taken the necessary precautions to prevent ESD damage.
- Ensure that you have connected the device chassis to earth ground.



CAUTION: Before you connect power to the services gateway, a licensed electrician must attach a cable lug to the grounding and power cables that you use. A cable with an incorrectly attached lug can damage the device (for example, by causing a short circuit).

To meet safety and electromagnetic interference (EMI) requirements and to ensure proper operation, you must connect the SRX240 Services Gateway to ground before you connect it to power.

You connect DC source power to the device by attaching power cables from the external DC power sources to the terminal studs on the DC power feed faceplates.

To connect the DC source power to the device:

1. Ensure that the input circuit breaker is open so that the voltage across the DC power source cable leads is 0 V and that the cable leads will not become active while you are connecting DC power.



NOTE: The DC power feed in SRX240 Services Gateway DC power supply model has four terminals labeled A+, B+, A–, and B– for connecting DC power source cables labeled positive (+) and negative (–). The DC power feed section on the SRX240 Services Gateway with DC power supply model is shipped with jumpers from the A+ input to B+ input tied together and links (jumpers) from the A– input to B– input tied together.

2. Remove the screw securing the terminal block cover using the Phillips (+) screwdriver, number 1 and remove the terminal block cover as shown in [Figure 13 on page 52](#). Save the screw.

Figure 13: DC Power Feed on SRX240 Services Gateway with DC Power Supply Model

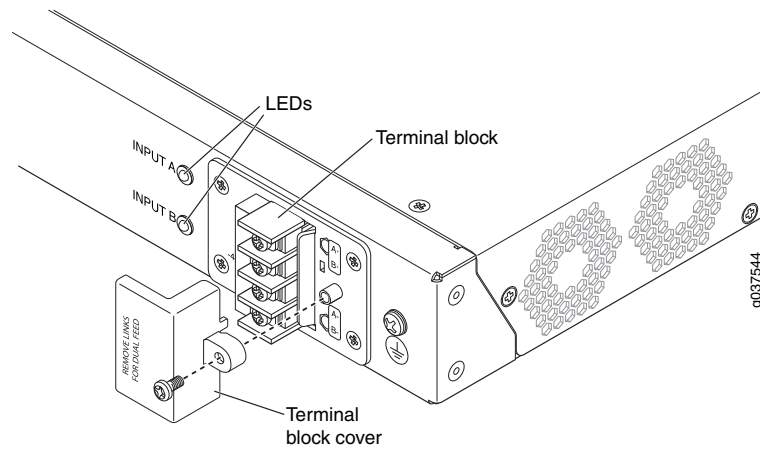

3. Remove the screws on the terminals using the Phillips (+) screwdriver, number 1. Save the screws.



WARNING: Ensure that the power cables do not block access to the device or drape where people can trip on them.

4. Connect the power feed to the power sources as shown in [Figure 14 on page 53](#). Secure power source cables to the power feed on the device by screwing the ring lugs attached to the cables to the appropriate terminals by using the screw from the terminals.

Figure 14: Connecting DC Power to the SRX240 Services Gateway with DC Power Supply Model

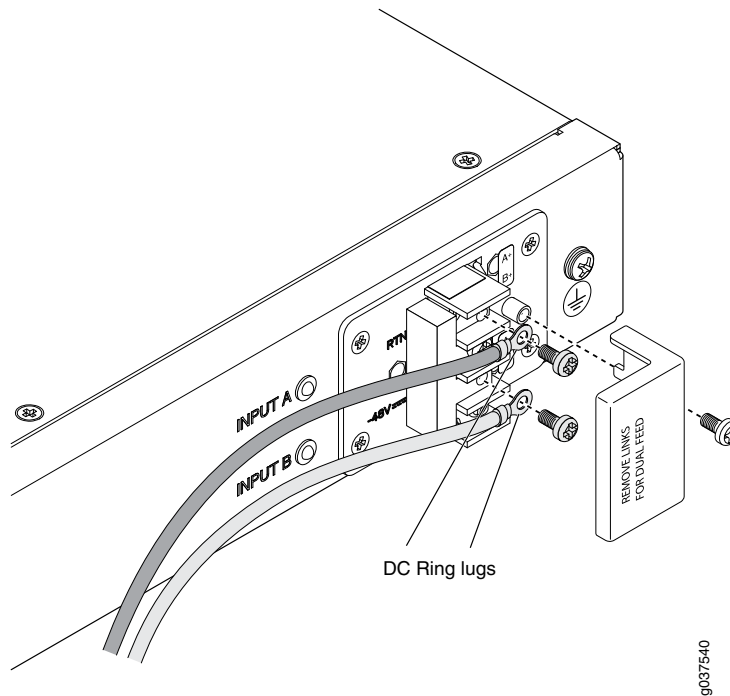

To connect to a single power source:

1. Leave the links (jumpers) on the terminal blocks in place.
2. Secure the ring lug of the RETURN (+) DC power source cable to the A+ terminal on the terminal block.
3. Secure the ring lug of the -48 VDC power source cable to the A- terminal on the terminal block.
4. Tighten the screws on the power supply terminals until snug using the Phillips (+) screwdriver, number-2. Do not overtighten—apply between 8 lb-in. (0.9 Nm) and 9 lb-in. (1.02 Nm) of torque to the screws.

To connect to two power sources:

1. Remove the links (jumpers) and insulator on the power supply terminal block.
2. Secure the ring lug of the RETURN (+) DC power source cable from the first DC power source to the A+ terminal.
3. Secure the ring lug of the -48V DC power source cable from the first DC power source to the A- terminal.
4. Secure the ring lug of the Return (+) DC power source cable from the second DC power source to the B+ terminal.

5. Secure the ring lug of the -48VDC power source cable from the second DC power source to the B- terminal.
6. Tighten the screws on the power supply terminals using the Phillips (+) screwdriver, number 1. Do not overtighten—apply between 8 lb-in. (0.9 Nm) and 9 lb-in. (1.02 Nm) of torque to the screws.
5. Replace the terminal block cover and secure it using the screw. Use the Phillips (+) screwdriver, number 1 to tighten the screw.
6. Close the input circuit breaker.
7. Verify that the power cables do not block access to router components or drape where people can trip on them. Use the cable tie holder as shown in [Figure 15 on page 54](#) to secure cables so that they are not supporting their own weight as they hang to the floor

Figure 15: Organizing the Power Cables Using a Cable Tie Holder

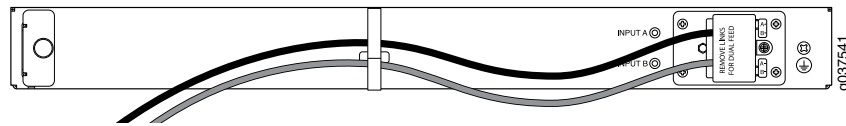

8. Verify that the LEDs on the power supply are lit green and are on steadily.

Related Documentation

- [SRX240 Services Gateway Power Supply on page 20](#)
- [SRX240 Services Gateway DC Power Specifications and Requirements on page 146](#)
- [SRX240 Services Gateway LEDs on page 14](#)
- [Required Tools and Parts for Installing and Maintaining the SRX240 Services Gateway on page 39](#)
- [Grounding the SRX240 Services Gateway on page 55](#)
- [Powering On and Powering Off the SRX240 Services Gateway on page 57](#)

Connecting and Organizing Interface Cables to the SRX240 Services Gateway

You connect the interfaces installed in the services gateway to various network media. Each type of interface on a services gateway uses a particular medium to transmit data. You must configure each network interface before it can operate on the device.

To connect the interface cable to the device:

1. Have ready a length of the type of cable used by the interface.
2. Insert the cable connector into the cable connector port on the interface faceplate.
3. Arrange network cables as follows to prevent them from dislodging or developing stress points:
 - Secure cables so that they are not supporting their own weight as they hang to the floor.

- Place excess cable out of the way in neatly coiled loops.
- Use fasteners to maintain the shape of cable loops.

Related Documentation

- [Installing the SRX240 Services Gateway on page 44](#)
- [Grounding the SRX240 Services Gateway on page 55](#)
- [Connecting the SRX240 Services Gateway to the AC Power Source on page 49](#)
- [Powering On and Powering Off the SRX240 Services Gateway on page 57](#)

Grounding the SRX240 Services Gateway

The following tools and parts are required for grounding the SRX240 Services Gateway:

- Grounding cable for your services gateway—The grounding cable must be minimum 14 AWG (2 mm²), minimum 90°C wire, or as permitted by the local code.
- Grounding lug—Ring-type, vinyl-insulated TV14-6R lug or equivalent for your grounding cable
- Washers and 10-32x.25-in. screws to secure the grounding lug to the protective earthing terminal
- Phillips (+) screwdrivers, numbers 1 and 2

Figure 16 on page 55 shows the SRX240 grounding point.

Figure 16: Grounding the SRX240 Services Gateway

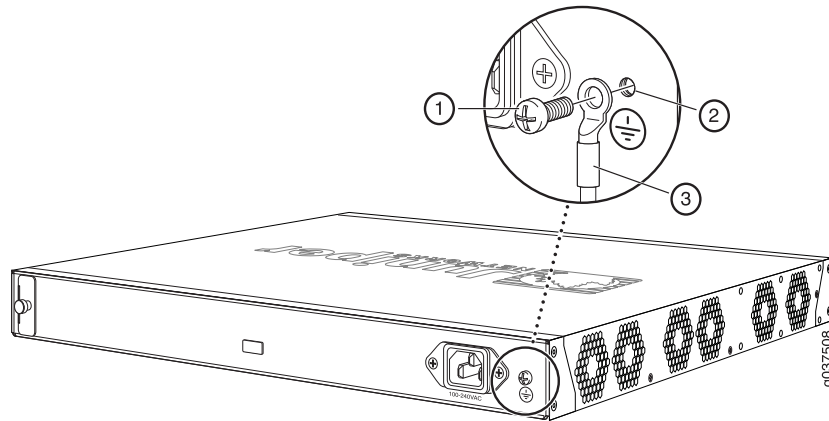

You ground the device by connecting a grounding cable to earth ground and then attaching it to the chassis grounding points using one M3 screw.

Table 24 on page 55 lists the specifications of the grounding cable used with the device.

Table 24: Grounding Cable Specifications for the Services Gateway

Grounding Requirement	Specification
Grounding cable	14 AWG single-strand wire cable

Table 24: Grounding Cable Specifications for the Services Gateway (continued)

Grounding Requirement	Specification
Amperage of grounding cable	Up to 4 A
Grounding lug	Ring-type, vinyl-insulated TV14-6R lug or equivalent



CAUTION: Before device installation begins, a licensed electrician must attach a cable lug to the grounding and power cables that you use. A cable with an incorrectly attached lug can damage the device (for example, by causing a short circuit).

To ground the device:

1. Connect the grounding cable to a proper earth ground.
2. Verify that a licensed electrician has attached the cable lug to the grounding cable.
3. Place the grounding cable lug over the grounding point on the upper rear of the chassis.
4. Secure the grounding cable lug to the grounding point with the screw. Apply between 6 in.-lb (0.67 Nm) and 8 in.-lb (0.9 Nm) of torque to the screws.
5. Dress the grounding cable and verify that it does not touch or block access to the services gateway components and that it does not cause create a tripping hazard.



NOTE: The device should be permanently connected to ground during normal operation.

Related Documentation

- [Installing the SRX240 Services Gateway on page 44](#)
- [Required Tools and Parts for Installing and Maintaining the SRX240 Services Gateway on page 39](#)
- [Connecting and Organizing Interface Cables to the SRX240 Services Gateway on page 54](#)
- [Connecting the SRX240 Services Gateway to the AC Power Source on page 49](#)
- [Powering On and Powering Off the SRX240 Services Gateway on page 57](#)

Powering On and Powering Off the SRX240 Services Gateway

This topic includes the following sections:

- [Powering On the SRX240 Services Gateway on page 57](#)
- [Powering Off the SRX240 Services Gateway on page 57](#)
- [Resetting the SRX240 Services Gateway on page 59](#)

Powering On the SRX240 Services Gateway

To power on the services gateway:

1. Ensure that you have connected the power supply to the services gateway.
2. Insert the plug into an AC power source receptacle (for SRX240 Services Gateway with AC power supply, and PoE).

Or

Attach the power cable to the DC power source (for SRX240 Services Gateway with DC power supply model). Ensure that the DC power source is connected according to the guidelines recommended in [“Connecting the SRX240 Services Gateway DC Power Supply Model to a DC Power Source” on page 50](#).

3. The services gateway starts up as the power supply completes its startup sequence. The Power LED glows during startup and remains on steadily when the services gateway is operating normally.



NOTE: After the power supply is turned on, it can take up to 60 seconds for status indicators—such as the Status and Power LEDs on the front panel of chassis to show that the power supply is functioning normally.



NOTE: We recommend that you issue the CLI command `request system power-off` when you want to power off the device immediately after the device is powered on.

Powering Off the SRX240 Services Gateway

You can power off the services gateway in one of the following ways:

- Graceful shutdown—Press and immediately release the Power button. The device begins gracefully shutting down the operating system and then powers itself off.



WARNING: Use the graceful shutdown method to power off or reboot the services gateway.

- Forced shutdown—Press the Power button and hold it for 10 seconds. The device immediately powers itself off without shutting down the operating system.



WARNING: Use the forced shutdown method as a last resort to recover the services gateway if the services gateway operating system is not responding to the graceful shutdown method.



WARNING: Do not press the Power button while the services gateway is shutting down.



CAUTION: Forced shutdown can result in data loss and corruption of the file system.



NOTE: To remove power completely from the services gateway, unplug the AC power cord (for SRX240 Services Gateway with AC power supply, and PoE models) or switch off the DC power source (SRX240 Services Gateway with DC power supply).

After powering off a power supply, wait at least 10 seconds before turning it back on. After powering on a power supply, wait at least 10 seconds before turning it off.

The Power button on the services gateway is a standby power switch.

If you press the Power button to power off the services gateway when it is still connected to a power source, 12 V (for SRX240 Services Gateway with AC and DC Power Supply models) / 52 V (SRX240 Services Gateway PoE models) power will still be available in the chassis and the device will be fully powered off.



TIP: When you are powering off the services gateway, the following message is displayed:

Turning the system power off.

You can now safely remove the power cable to completely disconnect the power from the device.



NOTE: You can use the request system reboot command to schedule a reboot of the services gateway.

For more information about halting, powering off, or rebooting the services gateway using the CLI, see the following guides:

- [Initial Configuration for Security Devices](#)
- [Monitoring and Troubleshooting for Security Devices](#)

Resetting the SRX240 Services Gateway

The RESET CONFIG button located at the front panel of the SRX240 Services Gateway removes the current configuration and resets the device to the default configuration. The button is recessed in the front panel to prevent it from being pressed accidentally.



NOTE: Pressing and holding the RESET CONFIG button for 15 seconds or more deletes all configurations on the device and loads and commits the factory configuration.

Related Documentation

- [Required Tools and Parts for Installing and Maintaining the SRX240 Services Gateway on page 39](#)
- [Connecting and Organizing Interface Cables to the SRX240 Services Gateway on page 54](#)
- [Connecting the SRX240 Services Gateway to the AC Power Source on page 49](#)
- [Connecting the SRX240 Services Gateway DC Power Supply Model to a DC Power Source on page 50](#)

SRX240 Services Gateway Autoinstallation

This chapter includes the following topic:

- [SRX240 Services Gateway Autoinstallation Overview on page 61](#)

SRX240 Services Gateway Autoinstallation Overview

The autoinstallation process begins any time a services gateway is powered on and cannot locate a valid configuration file in the internal flash. Typically, a configuration file is unavailable when a services gateway is powered on for the first time or if the configuration file is deleted from the internal flash. The autoinstallation feature enables you to deploy multiple services gateways from a central location in the network.

If you are setting up many devices, autoinstallation can help automate the configuration process by loading configuration files onto new or existing devices automatically over the network. You can use either the J-Web interface or the CLI to configure a device for autoinstallation.

For the autoinstallation process to work, you must store one or more host-specific or default configuration files on a configuration server in the network and have a service available—typically Dynamic Host Configuration Protocol (DHCP)—to assign an IP address to the services gateway.

Autoinstallation takes place automatically when you connect an Ethernet port on a new services gateway to the network and power on the device. To simplify the process, you can explicitly enable autoinstallation on a device and specify a configuration server, an autoinstallation interface, and a protocol for IP address acquisition.

For more information about configuring autoinstallation, see the following topics:

- [Initial Configuration for Security Devices](#)
- [Monitoring and Troubleshooting for Security Devices](#)

Related Documentation

- [Connecting the SRX240 Services Gateway to the AC Power Source on page 49](#)
- [Grounding the SRX240 Services Gateway on page 55](#)
- [Powering On and Powering Off the SRX240 Services Gateway on page 57](#)

Connecting the SRX240 Services Gateway to Management Devices

This chapter includes the following topics:

- [Connecting to the SRX240 Services Gateway Setup Wizard on page 63](#)
- [Connecting the SRX240 Services Gateway to the CLI on page 64](#)
- [Connecting the Modem at the SRX240 Services Gateway End on page 67](#)
- [Connecting the Modem to the Console Port on the SRX240 Services Gateway on page 68](#)
- [Connecting to the CLI at the User End for the SRX240 Services Gateway on page 69](#)

Connecting to the SRX240 Services Gateway Setup Wizard

If you plan to use the setup wizard to configure the services gateway, you must connect through one of the built-in Gigabit Ethernet ports. You can use any built-in Ethernet port except port 0/0.

To enable communication between the management device and the services gateway, ports 0/1 through 0/15 are preconfigured with the IP address **192.168.1.1**. DHCP is used to assign an IP address on the **192.168.1.0/24** network to any connected device.

To connect to the Ethernet port:

1. Ensure that the IP address for the Ethernet port on the management device is configured in one of the following ways:
 - The IP address is assigned by DHCP.
 - The IP address is on the **192.168.1.0/24** subnetwork (but is not **192.168.1.1**).
2. Turn off the management device.
3. Plug one end of the CAT-5e (Ethernet cable) into the Ethernet port on the management device.
4. Connect the other end of the Ethernet cable to the built-in Gigabit Ethernet port (any one port between 0/1 and 0/15) on the services gateway as shown in [Figure 17 on page 64](#).

Figure 17: Connecting to the Ethernet Port on an SRX240 Services Gateway

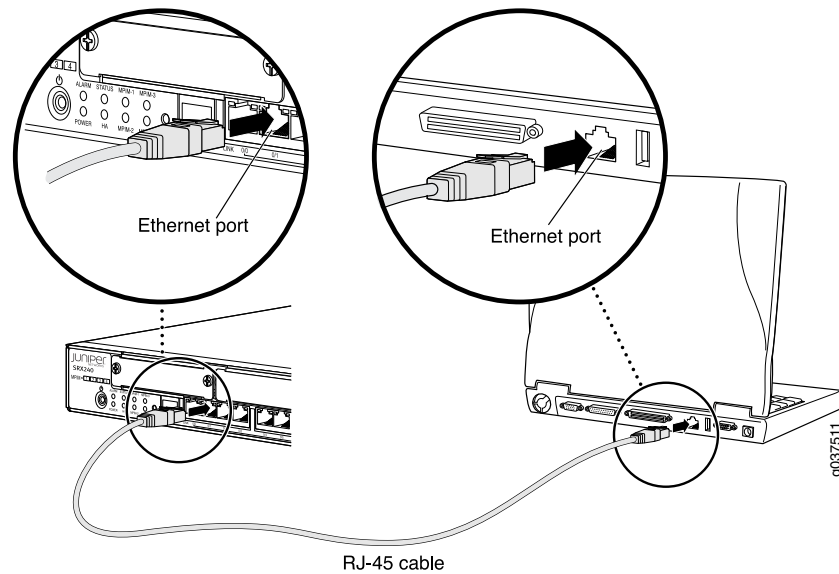

If the services gateway has not already been powered on, power it on now.

5. Wait until the Status LED on the front panel of the services gateway turns steadily green.
6. Turn on the power to the management device. The services gateway assigns an IP address to the management device within the **192.168.1.0/24** subnetwork if the management device is configured to use DHCP.
7. To access the setup wizard, open a Web browser on the management device and enter the IP address **192.168.1.1** in the address field.

Related Documentation

- [Performing Initial Software Configuration on the SRX240 Services Gateway Using the Setup Wizard on page 75](#)
- [Connecting the SRX240 Services Gateway to the CLI on page 64](#)
- [Connecting to the CLI at the User End for the SRX240 Services Gateway on page 69](#)
- [Connecting the Modem at the SRX240 Services Gateway End on page 67](#)
- [Connecting the Modem to the Console Port on the SRX240 Services Gateway on page 68](#)

Connecting the SRX240 Services Gateway to the CLI

This topic includes the following sections:

- [Connecting the Services Gateway to the CLI Locally on page 65](#)
- [Connecting a Services Gateway to the CLI Remotely on page 66](#)

Connecting the Services Gateway to the CLI Locally

If you plan to use the CLI to configure the SRX240 Services Gateway, you must connect the services gateway through the console port as shown in [Figure 18 on page 65](#).

Figure 18: Connecting an SRX240 Services Gateway to the CLI

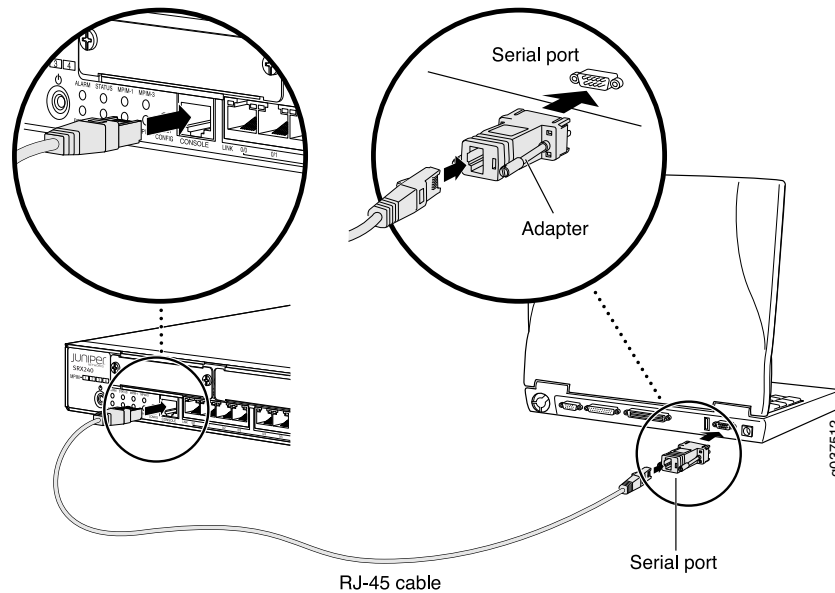

NOTE: [Figure 18 on page 65](#) shows a connection to a local management device. A remote connection to the services gateway through a modem requires the cable and connector shown (provided in the services gateway accessory box), plus a DB-9 male to DB-25 male (or similar) adapter for your modem, which you must purchase separately.

To connect to the CLI using a local management device through the console port on the services gateway:

1. Turn off power to the services gateway.
2. Turn off power to the management device, such as a PC or laptop computer, that you are using to access the CLI.
3. Plug one end of the CAT-5e (Ethernet cable) supplied with your services gateway into the RJ-45 to DB-9 serial port adapter supplied with your services gateway.
4. Plug the RJ-45 to DB-9 serial port adapter into the serial port on the management device.
5. Connect the other end of the Ethernet cable to the console port on the services gateway.
6. Turn on the power to the management device.

7. Start your asynchronous terminal emulation application (such as Microsoft Windows HyperTerminal) and select the appropriate **COM** port to use (for example, **COM1**).
8. Configure the port settings shown in [Table 25 on page 66](#).

Table 25: Port Settings When Connecting the Services Gateway to the CLI Locally

Port Settings	Value
Bits per second	9600
Data bits	8
Parity	None
Stop bits	1
Flow control	None

9. Power on the services gateway by pressing the Power button on the front panel. Verify that the Power LED on the front panel turns green.

The terminal emulation screen on your management device displays the startup sequence. When the services gateway has finished starting up, a login prompt appears.
10. Log in as the user **root**. No password is required at initial connection, but you must assign a root password before committing any configuration settings.

Connecting a Services Gateway to the CLI Remotely

You can connect the services gateway to the CLI from a remote location through two dial-up modems:

- A modem that is connected to the console port on the services gateway
- A second modem connected to a remote management device

The modem connection allows you to remotely perform the same console operations you can perform locally.

Related Documentation

- [Connecting to the SRX240 Services Gateway Setup Wizard on page 63](#)
- [Connecting to the CLI at the User End for the SRX240 Services Gateway on page 69](#)
- [Connecting the Modem at the SRX240 Services Gateway End on page 67](#)
- [Connecting the Modem to the Console Port on the SRX240 Services Gateway on page 68](#)

Connecting the Modem at the SRX240 Services Gateway End

Before you can connect a dial-up modem to the console port on the SRX240 Services Gateway, you must configure the modem to accept a call on the first ring and accept DTR signals. You must also disable flow control on the modem.



NOTE: These instructions use Hayes-compatible modem commands to configure the modem. If your modem is not Hayes-compatible, refer to the documentation for your modem and enter the equivalent modem commands.

To configure the modem on the services gateway end:

1. Connect the modem to a PC or laptop computer.
2. Power on the modem.
3. From the PC or laptop computer, start your asynchronous terminal emulation application (such as Microsoft Windows HyperTerminal), and select the **COM** port to which the modem is connected (for example, **COM1**).
4. Configure the port settings as shown in [Table 26 on page 67](#).

Table 26: Port Settings for Configuring the Modem on the Services Gateway End

Port Setting	Value
Bits per second	9600
Data bits	8
Parity	None
Stop bits	1
Flow control	None

5. In the HyperTerminal window, enter **AT**.

For more information on the AT commands, see the following topics:

- [Initial Configuration for Security Devices](#)
- [Monitoring and Troubleshooting for Security Devices](#)

An **OK** response verifies that the modem can communicate successfully with the **COM** port on the PC or laptop.

6. Configure the modem to answer a call on the first ring by entering **ATS0=1**.
7. Configure the modem to accept modem control DTR signals by entering **AT&D1**.

8. Disable flow control by entering **AT&K0**.
9. Save modem settings by entering **AT&W**.

Related Documentation

- [Connecting to the SRX240 Services Gateway Setup Wizard on page 63](#)
- [Connecting the SRX240 Services Gateway to the CLI on page 64](#)
- [Connecting to the CLI at the User End for the SRX240 Services Gateway on page 69](#)
- [Connecting the Modem to the Console Port on the SRX240 Services Gateway on page 68](#)

Connecting the Modem to the Console Port on the SRX240 Services Gateway

To connect the dial-up modem to the console port on the services gateway:

1. Turn off power to the services gateway.
2. Turn off power to the modem.
3. Plug one end of the Ethernet cable supplied with your services gateway into the console port.
4. Plug the other end of the CAT-5e (Ethernet cable) into the RJ-45 to DB-9 serial port adapter supplied with your services gateway.
5. Connect the serial port adapter to a separately purchased DB-9 female to DB-25 male adapter or other adapter appropriate for your modem.
6. Plug the modem adapter into the DB-25 connector on the modem.
7. Connect the modem to your telephone network.
8. Turn on the power to the modem.
9. Power on the services gateway by pressing the Power button on the front panel. Verify that the Power LED on the front panel turns green.



.....
NOTE: Most modems have an RS-232 DB-25 connector. You must separately purchase an adapter to connect your modem to the RJ-45 to DB-9 adapter and Ethernet cable supplied with the services gateway.
.....

Related Documentation

- [Connecting to the SRX240 Services Gateway Setup Wizard on page 63](#)
- [Connecting the SRX240 Services Gateway to the CLI on page 64](#)
- [Connecting the Modem at the SRX240 Services Gateway End on page 67](#)
- [Connecting to the CLI at the User End for the SRX240 Services Gateway on page 69](#)

Connecting to the CLI at the User End for the SRX240 Services Gateway

To remotely connect to the CLI through a dial-up modem connected to the console port on the services gateway:

1. Connect a modem at your remote location to a management device such as a PC or laptop computer.
2. Start your asynchronous terminal emulation application (such as Microsoft Windows HyperTerminal) on the PC or laptop computer.
3. Select the **COM** port to which the modem is connected (for example, **COM1**).
4. Configure the port settings shown in [Table 27 on page 69](#).

Table 27: Port Settings for Connecting to the CLI at User End

Port Setting	Value
Bits per second	9600
Data bits	8
Parity	None
Stop bits	1
Flow control	None

5. In the HyperTerminal window, enter **AT**.

For more information on the AT commands, see the following topics:

- [Initial Configuration for Security Devices](#)
- [Monitoring and Troubleshooting for Security Devices](#)

An **OK** response verifies that the modem can communicate successfully with the **COM** port on the PC or laptop.

6. Dial the modem that is connected to the console port on the services gateway by entering **ATDT remote-modem-number**. For example, if the number of the modem connected to the console port on the services gateway is **0013033033030**, enter **ATDT 0013033033030**.

The services gateway login prompt appears.

7. Log in as the user **root**. No password is required at initial connection, but you must assign a root password before committing any configuration settings.

Related Documentation

- [Connecting to the SRX240 Services Gateway Setup Wizard on page 63](#)
- [Connecting the SRX240 Services Gateway to the CLI on page 64](#)
- [Connecting the Modem at the SRX240 Services Gateway End on page 67](#)

- [Connecting the Modem to the Console Port on the SRX240 Services Gateway on page 68](#)

CHAPTER 13

Performing Initial Software Configuration on the SRX240 Services Gateway

This chapter includes the following topics:

- [SRX240 Services Gateway Software Configuration Overview on page 71](#)
- [Performing Initial Software Configuration on the SRX240 Services Gateway Using the Setup Wizard on page 75](#)
- [Performing Initial Software Configuration on the SRX240 Services Gateway Using the CLI on page 78](#)
- [Performing Initial Software Configuration on the SRX240 Services Gateway Using the J-Web Interface on page 80](#)
- [SRX240 Services Gateway Secure Web Access Overview on page 85](#)

SRX240 Services Gateway Software Configuration Overview

This topic includes the following sections:

- [Preparing the SRX240 Services Gateway for Configuration on page 71](#)
- [Understanding the Factory Default Configuration on page 72](#)
- [Understanding Built-In Ethernet Ports and Initial Configuration on page 72](#)
- [Mapping the Chassis Cluster Ports on page 73](#)
- [Understanding Management Access on page 74](#)

Preparing the SRX240 Services Gateway for Configuration

The services gateway is shipped with the Juniper Networks Junos operating system (Junos OS) preinstalled. When the services gateway is powered on, it is ready to be configured.

You can perform the initial configuration of the services gateway by using the browser-based setup wizard or by using the command-line interface (CLI).

Before configuring the services gateway, gather the configuration information required to deploy the services gateway in your network. At minimum, the setup wizard requires the following information:

- Device name to be used on the network

- Password for the root user
- Time information for the services gateway location:
 - Local time zone
 - Name or IP address of a Network Time Protocol (NTP) server, if NTP is used to set the time on the services gateway
 - Local date and time if an NTP server is not used to set the time

Understanding the Factory Default Configuration

Your services gateway comes configured with a default configuration. This factory default configuration sets up the following network topology:

- Interface ge-0/0/0 (port 0/0) is configured for Internet access. A DHCP client running on the interface enables the interface to receive its network settings—IP address, default gateway, and DNS servers—from an Internet service provider (ISP).
- Interfaces ge-0/0/1 through ge-0/0/15 (port 0/1 through port 0/15) are configured as switched interfaces in a VLAN on which the IP address **192.168.1.1/24** is configured.
- A DHCP server is active on interfaces ge-0/0/1 through ge-0/0/15. The DHCP server assigns IP addresses in the **192.168.1.0/24** network to connected devices.

The default configuration also includes the following security configuration:

- Two security zones are created: trust and untrust.
- Interface ge-0/0/0 is in the untrust zone, while interfaces ge-0/0/1 through ge-0/0/15 are in the trust zone.
- A security policy is created that permits outbound traffic from the trust zone to the untrust zone. Inbound traffic originating in the untrust zone is blocked.
- Source Network Address Translation (NAT) is configured on the trust zone.

Understanding Built-In Ethernet Ports and Initial Configuration

During the initial configuration of the services gateway, how you use the built-in Ethernet ports (ports 0/0 through 0/15) depends on the initial configuration you are performing:

- Configuration using autoinstallation—Use the built-in Ethernet port 0/0 to connect to the DHCP server. A DHCP client is configured on this interface, allowing the services gateway to receive its IP address from the DHCP server.
- Configuration using the setup wizard—Use the following built-in Ethernet ports:
 - Port 0/1—Connect your management device to this port. A DHCP server running on this interface automatically assigns your management device an IP address on the same subnetwork as the interface, allowing your management device to communicate with the services gateway through this interface.

- Port 0/0—Connect your services gateway to the Internet on this port if you plan to download purchased software licenses through the setup wizard. A DHCP client running on this interface allows it to receive its network settings from the ISP.



NOTE: Downloading of purchased licenses from the setup wizard is available only in Junos OS Release 11.2R3 or later.

- Configuration of a chassis cluster—Perform the initial configuration of the chassis cluster using a console connection. Before you perform the initial configuration, connect the built-in Ethernet ports as follows:
 - Port 0/0—Connect to the out-of-band management network for management of the services gateway. When you enable chassis clustering as part of configuring the chassis cluster, the management interface (**fxp0**) is automatically created on this port.
 - Port 0/1—Connect to the other device in the chassis cluster. When you enable chassis clustering, the control interface between the two devices (**fxp1**) is automatically created on this port.

You must also make another connection between the two devices for the fabric link. You can use any available Gigabit Ethernet port for this connection. You must configure the interface you choose as the fabric link. For more information on configuring chassis clusters, see the [Security Basics](#).

Mapping the Chassis Cluster Ports

A chassis cluster is created by physically connecting two identical SRX240 Services Gateways together using a pair of the same type of Ethernet connections. The connection is made for both a control link and a fabric (data) link between the two services gateway.

The **fxp0** port is dedicated as the out-of-band management interface for each of the services gateway in the chassis cluster setup and the **fxp1** port is dedicated as the chassis-cluster control port.

On the SRX240 Services Gateway, the **fxp1** port is not user configurable when the services gateway is operating in chassis cluster mode.

[Table 28 on page 73](#) shows the mapping of the chassis cluster ports.

Table 28: Mapping the Chassis Cluster Ports on an SRX240 Services Gateway

Ethernet Ports on SRX240 Services Gateway	Management Interface
0/0 (ge-0/0/0)	fxp0 (management port)
0/1 (ge-0/0/1)	fxp1 (control port)



NOTE: On SRX240 Services Gateway, the fabric link connection can be any pair of Gigabit Ethernet interfaces.

Junos OS automatically creates the `fxp0` and `fxp1` interfaces on these ports when the SRX240 Services Gateway is operating in chassis cluster mode.

For more information, see the following guides:

- [Security Basics](#)
- [Interfaces for Security Devices](#)

Understanding Management Access

Telnet allows you to connect to the services gateway and access the CLI to execute commands from a remote system. Telnet CLI connections are not encrypted and therefore can be intercepted.



NOTE: Telnet access to the root user is prohibited. You must use more secure methods, such as SSH, to log in as root.

SSH provides the following features:

- Allows you to connect to the services gateway and access the CLI to execute commands from a remote system
- Encrypts traffic so that it cannot be intercepted (unlike Telnet)
- Can be configured so that connections are authenticated by a digital certificate
- Uses public–private key technology for both connection and authentication

The SSH client software must be installed on the machine where the client application runs. If the SSH private key is encrypted (for greater security), the SSH client must be able to access the passphrase used to decrypt the key.

For information about obtaining SSH software, see <http://www.ssh.com> and <http://www.openssh.com>.

If you are using a Junos XML protocol server to configure and monitor devices, you can activate cleartext access on the device to allow unencrypted text to be sent directly over a Transmission Line Protocol (TCP) connection without using any additional protocol (such as SSH, SSL, or Telnet). For more information about the Junos XML management protocol, see the [Junos XML Management Protocol Guide](#).



NOTE: Information sent in cleartext is not encrypted and therefore can be intercepted.

If the device is operating in a Common Criteria environment, see the [Configuration Guides for Junos OS Public Sector Certifications](#).

Related Documentation

- [Connecting to the SRX240 Services Gateway Setup Wizard on page 63](#)
- [Connecting the SRX240 Services Gateway to the CLI on page 64](#)
- [Performing Initial Software Configuration on the SRX240 Services Gateway Using the CLI on page 78](#)
- [Performing Initial Software Configuration on the SRX240 Services Gateway Using the Setup Wizard on page 75](#)
- [SRX240 Services Gateway Secure Web Access Overview on page 85](#)

Performing Initial Software Configuration on the SRX240 Services Gateway Using the Setup Wizard

This topic describes how to perform the initial software configuration of your services gateway using the setup wizard available in Junos OS Release 11.2R3 or later. If your services gateway is running an earlier version of Junos OS, see “[Performing Initial Software Configuration on the SRX240 Services Gateway Using the J-Web Interface](#)” on page 80.

This topic includes the following sections:

- [About the Setup Wizard on page 75](#)
- [About the Default Setup Mode on page 76](#)
- [About the Guided Setup Mode on page 76](#)
- [Running the Setup Wizard on page 77](#)

About the Setup Wizard

The setup wizard guides you step-by-step through configuring a services gateway that can securely pass traffic. To help guide you through the process, the wizard:

- Provides recommended settings based on your previous selections. For example, the wizard recommends security policies based on the security topology you have defined.
- Determines which configuration tasks to present to you based on your selections. If a configuration task is unnecessary given your selections, the wizard skips it.
- Flags any missing required configuration when you attempt to leave a page.
- Indicates which configuration elements or tasks are unavailable to you based on your previous selections by graying them out.

You choose one of two paths through the wizard by selecting the configuration mode:

- **Default Setup mode**—This mode allows you to quickly set up a services gateway in a default security configuration.
- **Guided Setup mode**—This mode allows you to set up a services gateway in a custom security configuration.

About the Default Setup Mode

If you choose the Default Setup mode, the wizard takes you through the minimal configuration needed to set up the services gateway to securely pass traffic in the default configuration. The resulting configuration is similar to the factory default configuration described in [“SRX240 Services Gateway Software Configuration Overview” on page 71](#), except that the untrust and trust zones are renamed Internet and Internal zones.

In the Default Setup mode, you configure:

- The device name
- The password for the root account
- Time information for services the gateway location:
 - Local time zone
 - Name or IP address of a Network Time Protocol (NTP) server, if NTP is used to set the time on the services gateway
 - Local date and time if an NTP server is not used to set the time

The wizard also gives you the option of using the free 30-day trial licenses or downloading purchased licenses. You cannot do additional configuration in the Default Setup mode—you must commit your changes and exit the wizard to perform any additional configuration. You can perform additional configuration by rerunning the wizard in the Guided Setup mode, by using the J-Web interface, or by using the CLI.

See [“SRX240 Services Gateway Software Configuration Overview” on page 71](#) for step-by-step instructions on how to configure your services gateway in the Default Setup mode.

About the Guided Setup Mode

If you choose the Guided Setup mode, the wizard guides you through configuring your services gateway in a custom security configuration. Configuration you can perform with the setup wizard includes:

- Specifying a static IP address, default gateway, and DNS servers for the Internet interface
- Creating user accounts and specifying roles for the accounts
- Defining security zones and specifying which interfaces are in each zone
- Enabling a DHCP server in a zone
- Specifying what services—such as HTTP or SCP—are available in a zone
- Creating VLANs
- Defining security policies and Network Address Translation (NAT) rules
- Creating a virtual private network (VPN) for remote users



NOTE: In the Guided Setup mode, make sure you have configured the Ethernet interface you will be using for management access before you commit the configuration. If you do not do so, you can lose access to the J-Web interface.

If you lose access to the J-Web interface, you can:

- Make a console connection to the services gateway and configure access using the CLI.
- Reset the services gateway to its factory default configuration as described in [“Loading the Rescue Configuration on the SRX240 Services Gateway” on page 105](#). This allows you to regain access to the setup wizard and restart the initial configuration.

Running the Setup Wizard

To run the setup wizard:

1. Connect a laptop or desktop computer to any of the ports 0/1 through 0/15 as described in [“Connecting to the SRX240 Services Gateway Setup Wizard” on page 63](#).
2. If you will be using the setup wizard to download purchased licenses, connect your services gateway to the Internet on port 0/0.
3. Open a Web browser on your laptop or desktop.



NOTE: Supported browsers are Windows Internet Explorer versions 7, 8, and 9 and Mozilla Firefox versions 4 and 5. The minimum screen resolution is 800 by 600 pixels.

4. Enter one of the following URLs: <http://192.168.1.1> or <https://192.168.1.1>

When the Welcome page for the setup wizard appears, choose the setup mode you want to use to configure the services gateway.

After you finish configuring the services gateway with the setup wizard and commit your configuration, you are redirected to the J-Web interface. Thereafter, whenever you connect to the services gateway, you are placed in the J-Web interface. You can access the setup wizard from the J-Web interface and use it to reconfigure your services gateway. To do so, select **Configuration > Tasks > Run Setup Wizard**.

Related Documentation

- [Connecting to the SRX240 Services Gateway Setup Wizard on page 63](#)
- [SRX240 Services Gateway Software Configuration Overview on page 71](#)
- [Performing Initial Software Configuration on the SRX240 Services Gateway Using the CLI on page 78](#)
- [SRX240 Services Gateway Secure Web Access Overview on page 85](#)

Performing Initial Software Configuration on the SRX240 Services Gateway Using the CLI

This procedure connects the services gateway to the network but does not enable it to forward traffic. For complete information about enabling the services gateway to forward traffic, including examples, see the appropriate Junos OS configuration guides.

To configure the software:

1. Verify that the services gateway is powered on.
2. Log in as the root user. There is no password.
3. Start the CLI:

```
root# cli
root@>
```

4. Enter configuration mode:

```
configure
[edit]
root@#
```

5. Set the root authentication password by entering a cleartext password, an encrypted password, or an SSH public key string (DSA or RSA):

```
[edit]
root@# set system root-authentication plain-text-password
New password: password
Retype new password: password
```

6. Configure an administrator account on the services gateway:

```
[edit]
root@# set system login user admin class super-user authentication
plain-text-password
```

7. Commit the configuration to activate it on the services gateway:

```
[edit]
root@# commit
```

8. Log in as the administrative user you configured in Step 6.

9. Configure the name of the services gateway. If the name includes spaces, enclose the name in quotation marks (" "):

```
configure
[edit]
admin@# set system host-name host-name
```

10. Configure the traffic interface:

```
[edit]
admin@# set interfaces ge-0/0/1 unit 0 family inet address address/prefix-length
```

11. Configure the default route:

```
[edit]
admin@# set routing-options static route 0.0.0.0/0 next-hop gateway
```

12. Configure basic security zones and bind them to traffic interfaces:

```
[edit]
admin@# set security zones security-zone untrust interfaces ge-0/0/1
```

13. Configure basic security policies:

```
[edit]
admin@# set security policies from-zone trust to-zone untrust policy policy-name
match source-address any destination-address any application any
admin@# set security policies from-zone trust to-zone untrust policy policy-name
then permit
```

14. Create a NAT rule for source translation of all Internet-bound traffic:

```
[edit]
admin@# set security nat source rule-set interface-nat from zone trust
admin@# set security nat source rule-set interface-nat to zone untrust
admin@# set security nat source rule-set interface-nat rule rule1 match source-address
0.0.0.0/0 destination-address 0.0.0.0/0
admin@# set security nat source rule-set interface-nat rule rule1 then source-nat
interface
```

15. Check the configuration for validity:

```
[edit]
admin@# commit check
configuration check succeeds
```

16. Commit the configuration to activate it on the services gateway:

```
[edit]
admin@# commit
commit complete
```

17. Optionally, display the configuration to verify that it is correct:

```
[edit]
user@host# show
system {
  host-name devicea;
  domain-name lab.device.net;
  domain-search [ lab.device.net device.net ];
  backup-device 192.168.2.44;
  time-zone America/Los_Angeles;
  root-authentication {
    ssh-rsa "ssh-rsa AAAAB3Nza...D9Y2gXF9ac==root@devicea.lab.device.net";
  }
  name-server {
    10.148.2.32;
  }
  services {
  }
  ntp {
    server 10.148.2.21;
  }
}
```

```
}
interfaces {
  ge-0/0/0 {
    unit 0 {
      family inet {
        address 192.168.1.1/24;
      }
    }
  }
  lo0 {
    unit 0 {
      family inet {
        address 172.16.1.24/32;
      }
    }
  }
}
```

18. Commit the configuration to activate it on the services gateway:

```
[edit]
admin@# commit
```

19. Optionally, configure additional properties by adding the necessary configuration statements. Then commit the changes to activate them on the services gateway:

```
[edit]
admin@host# commit
```

20. When you have finished configuring the services gateway, exit configuration mode:

```
[edit]
admin@host# exit
admin@host>
```

- Related Documentation**
- [Connecting the SRX240 Services Gateway to the CLI on page 64](#)
 - [Performing Initial Software Configuration on the SRX240 Services Gateway Using the Setup Wizard on page 75](#)
 - [SRX240 Services Gateway Software Configuration Overview on page 71](#)
 - [SRX240 Services Gateway Secure Web Access Overview on page 85](#)

Performing Initial Software Configuration on the SRX240 Services Gateway Using the J-Web Interface

This topic describes how to perform the initial configuration of your services gateway using the J-Web setup wizard that is available in Junos OS Release 11.2R2 or earlier. If your services gateway is running Release 11.2R3 or later, see “Performing Initial Software Configuration on the SRX240 Services Gateway Using the Setup Wizard” on page 75.

This topic includes the following sections:

- [Establishing Basic Connectivity on page 81](#)
- [Configuring Basic System Properties on page 82](#)

Establishing Basic Connectivity

To establish basic connectivity:

1. Connect an Ethernet cable from any of the ports 0/1 through 0/15 to the Ethernet port on the management device (workstation or laptop).
2. Connect the power cable to the device and a power source. (We recommend using a surge protector.) Note the following indications:
 - Power LED (steadily green): The device is receiving power.
 - Status LED (steadily green): The device is operating normally.



NOTE: The services gateway functions as a DHCP server and will assign an IP address to the management device.

3. Ensure that the management device acquires an IP address on the 192.168.1.0/24 subnetwork (other than 192.168.1.1) from the device.



NOTE: If an IP address is not assigned to the management device, manually configure an IP address in the 192.168.1.0/24 subnetwork. Do not assign the 192.168.1.1 IP address to the management device, as this IP address is assigned to the services gateway.

4. Access the J-Web interface:
 - a. Launch a Web browser from the management device.



NOTE: To access the J-Web interface, your management device requires a supported browser: either Microsoft Internet Explorer version 7.0 (or later) or Mozilla Firefox version 3.0 (or later).

- b. Enter **192.168.1.1** in the Address box.
 - c. Specify the default user name as **root**. Do not enter any value in the Password box.
 - d. Press **Enter**. The J-Web Setup Wizard page opens.
5. Use the wizard to configure the basic settings, such as Hostname, Domain Name, and Root Password, for your services gateway.

The upper left area of the wizard page shows where you are in the setup process. Click a field in the wizard page to display information about that field in the lower left area of the page.

You can also use the wizard to configure the following settings:

- Default gateway
- DNS servers
- Domain search
- VLANs
- Interfaces



NOTE: All network and management access settings are optional.

See [Table 29 on page 82](#) and [Table 30 on page 83](#) summarize the configuration details for the initial setup.

6. Click **Commit** on the Review & Commit page to apply the configuration.



NOTE: After you configure the basic settings, the J-Web Setup wizard redirects you to the J-Web pages where you can continue working in the J-Web interface.

Configuring Basic System Properties

[Table 29 on page 82](#) and [Table 30 on page 83](#) summarize the configuration details for initial setup.

Table 29: Required Setup Fields

Setup Wizard Page	Field	Your Action
Introduction		Read the introduction page for basic instructions on using the setup wizard. Click Start to continue.
Configure System: Identification		

Table 29: Required Setup Fields (*continued*)

Setup Wizard Page	Field	Your Action
	Host Name	Type the name of the services gateway.
	Domain Name	Type the name of the network or subnetwork to which the services gateway belongs.
	Root Password (required)	Type the password that user root will use to log in to the device.
	Verify Root Password (required)	Retype the root password.
Configure J-Web Preferences		
	J-Web starting page options	Specify the tab you want to appear when J-Web starts.
	J-Web commit options	Specify when you want J-Web to commit your configuration changes.

Table 30: Optional Setup Fields

Field	Function	Your Action
Configure System: Identification		
	Default Gateway	Type the IP address of the default gateway.
	DNS Name Servers	Type the IP address of each server that maintains databases for resolving hostnames and IP addresses and click Add.
	Domain Search	Type the IP address or domain name of each domain that includes the services gateway to include it in a DNS search
Interface Groups (VLANs)		Use buttons to add, edit, or delete VLANs

Table 30: Optional Setup Fields (*continued*)

Field	Function	Your Action
Configure Interfaces		Use buttons to add, edit, or delete interfaces other than VLANs. NOTE: Make sure that you have selected the required services and protocols under Services (Inbound) and Protocols (Inbound). Select all to permit all protocols and services.
Configure System: Time		
	Current System Time	Use Reset Manually button to reset the time.
	Time Zone	Choose the time zone from the list
	NTP Servers	Add Network Time Protocol (NTP) servers that the gateway can reach to synchronize the system time.

After you configure basic setup, the Setup wizard is no longer available, unless you reset the device to the factory default and reboot it. To make changes to the configuration, use the J-Web interface or the command-line interface (CLI).

You can use other wizards to configure basic firewall policies, VPN settings, and NAT rules. Choose **Configure > Wizards** to use the available wizards. Use the J-Web interface or the CLI for more extensive configuration.

For more instructions on managing users and operations, monitoring network performance, upgrading software, and diagnosing common problems on an SRX240 Services Gateway, see the following guides:

- [Initial Configuration for Security Devices](#)
- [Monitoring and Troubleshooting for Security Devices](#)

Related Documentation

- [Connecting to the SRX240 Services Gateway Setup Wizard on page 63](#)
- [SRX240 Services Gateway Software Configuration Overview on page 71](#)
- [Performing Initial Software Configuration on the SRX240 Services Gateway Using the CLI on page 78](#)
- [SRX240 Services Gateway Secure Web Access Overview on page 85](#)

SRX240 Services Gateway Secure Web Access Overview

You can manage a services gateway remotely through the J-Web interface. To communicate with the services gateway, the J-Web interface uses Hypertext Transfer Protocol (HTTP). HTTP allows easy Web access but no encryption. The data that is transmitted between the Web browser and the services gateway by means of HTTP is vulnerable to interception and attack. To enable secure Web access, the services gateway supports HTTP over Secure Sockets Layer (HTTPS). You can enable HTTP or HTTPS access on specific interfaces and ports as needed.

The services gateway uses the SSL protocol to provide secure management of services gateways through the J-Web. SSL uses public-private key technology that requires a paired private key and an authentication certificate for providing the SSL service. SSL encrypts communication between your device and the Web browser with a session key negotiated by the SSL server certificate.

An SSL certificate includes identifying information such as a public key and a signature made by a certificate authority (CA). When you access the services gateway through HTTPS, an SSL handshake authenticates the server and the client and begins a secure session. If the information does not match or if the certificate has expired, your access to the services gateway through HTTPS is restricted.

Without SSL encryption, communication between your services gateway and the browser is sent in the open and can be intercepted. We recommend that you enable HTTPS access on your WAN interfaces.

For more information about configuring secure Web access, see the following topics:

- [Initial Configuration for Security Devices](#)
- [Monitoring and Troubleshooting for Security Devices](#)

Related Documentation

- [SRX240 Services Gateway Software Configuration Overview on page 71](#)
- [Performing Initial Software Configuration on the SRX240 Services Gateway Using the CLI on page 78](#)
- [Performing Initial Software Configuration on the SRX240 Services Gateway Using the Setup Wizard on page 75](#)

PART 3

Maintaining, Replacing, and Monitoring the SRX240 Services Gateway Hardware

- Maintaining the SRX240 Services Gateway Hardware Components on page 89
- Monitoring the SRX240 Services Gateway on page 95

Maintaining the SRX240 Services Gateway Hardware Components

This chapter includes the following topics:

- [Maintaining the SRX240 Services Gateway Hardware Components on page 89](#)
- [Replacing the Air Filter on the SRX240 Services Gateway on page 90](#)

Maintaining the SRX240 Services Gateway Hardware Components

[Table 31 on page 89](#) describes the common tasks to maintain the hardware components of the services gateway.

Table 31: Maintenance Procedures for the Services Gateway Hardware Components

Maintenance Procedures	Description
Routine Maintenance Procedures	<p>To maintain optimum performance of the services gateway, you must regularly perform the following preventive maintenance procedures:</p> <ul style="list-style-type: none"> • Inspect the installation site for moisture, loose wires or cables, and excessive dust. • Ensure that airflow is unobstructed around the device and into the air intake vents. • Check the Status LED on the front panel of the device and on the Mini-Physical Interface Module (Mini-PIM) you are using.
Maintaining the Cooling System	<p>The services gateway cooling system works to maintain an optimal temperature for the device. If the fan controller fails, the device temperature will exceed the maximum working temperature and the device will fail. Ensure that you maintain the recommended clearances behind the device to enable the cooling system to function optimally.</p>

Table 31: Maintenance Procedures for the Services Gateway Hardware Components (continued)

Maintenance Procedures	Description
Maintaining the Power Supply	<p>To maintain the power supply on the services gateway:</p> <ul style="list-style-type: none"> • Ensure that the power and grounding cables are arranged so that they do not obstruct access to other device components. • Periodically inspect the site to ensure that the grounding and power cables connected to the device are securely in place and that there is no moisture accumulating near the device. <p>CAUTION: We recommend using a surge protector for the power connection.</p>
Maintaining the Air Filter	<ul style="list-style-type: none"> • Periodically replace the filter in use. We recommend that you replace the filter every six months as a dirty air filter restricts airflow in the unit, reducing the ventilation of the chassis. The filter degrades over time. • Store spare air filter in a dark, cool, and dry place. Storing air filter at higher temperatures, or where they can be exposed to ultraviolet (UV) radiation, hydrocarbon emissions, or vapors from solvents, can significantly reduce their life. <p>NOTE: Always keep the air filter in place while the device is operating. Because the fans are very powerful, they could pull small bits of wire or other materials into the device through the unfiltered air intake. This could damage the device components.</p>

Related Documentation

- [Monitoring the SRX240 Services Gateway Components Using LEDs on page 97](#)
- [Monitoring the SRX240 Services Gateway Using Chassis Alarm Conditions on page 101](#)
- [Monitoring the SRX240 Services Gateway Power System on page 103](#)

Replacing the Air Filter on the SRX240 Services Gateway

The SRX240 Services Gateway High Memory with DC Power Supply model and SRX240 Services Gateway High Memory with AC Power Supply model has one air filter that installs vertically in the rear of the chassis. The air filter is hot-insertable and hot-removable.



NOTE: An air filter is not shipped with the SRX240 Services Gateway High Memory with AC Power Supply model. To meet NEBS requirements, you must order the air filter separately. Contact your Juniper Networks customer service representative for more information.

The air filter is located in the rear of the chassis on left side (from rear side view). The air filter weighs approximately 0.2 lb (0.09 kg).



CAUTION: Do not run NEBS-compliant services gateways (the SRX240 Services Gateway with DC Power Supply model and the SRX240 Services Gateway with AC Power Supply models) for more than a few minutes without the air filter in place.



CAUTION: Always keep the air filter in place while the device is operating, except during replacement. Because the fans are very powerful, they could pull small bits of wire or other materials into the device through the unfiltered air intake. This could damage the services gateway components.

To replace the air filter:

1. Attach an electrostatic discharge (ESD) grounding strap to your bare wrist, and connect the other end of the ESD strap to the ESD point on the rack.
2. Loosen the thumb-screw on the air filter. See [Figure 19 on page 91](#).

Figure 19: Loosening the Air Filter Screw

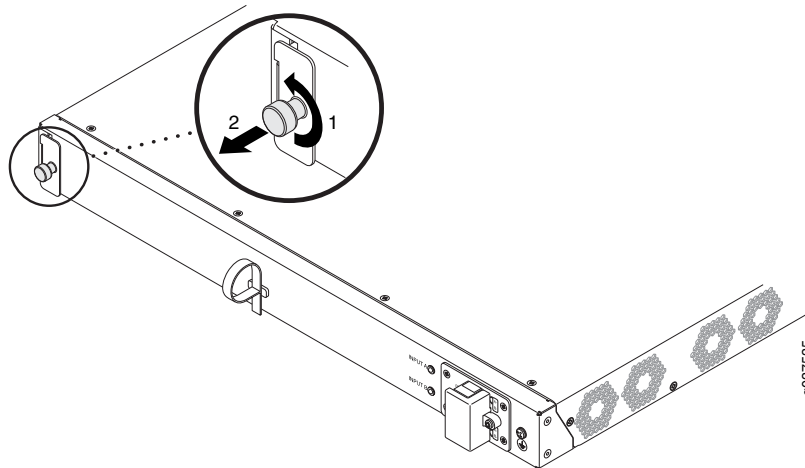

3. Slide the air filter out of the chassis and properly dispose of it. See [Figure 20 on page 92](#).

Figure 20: Removing the Air Filter from the Services Gateway

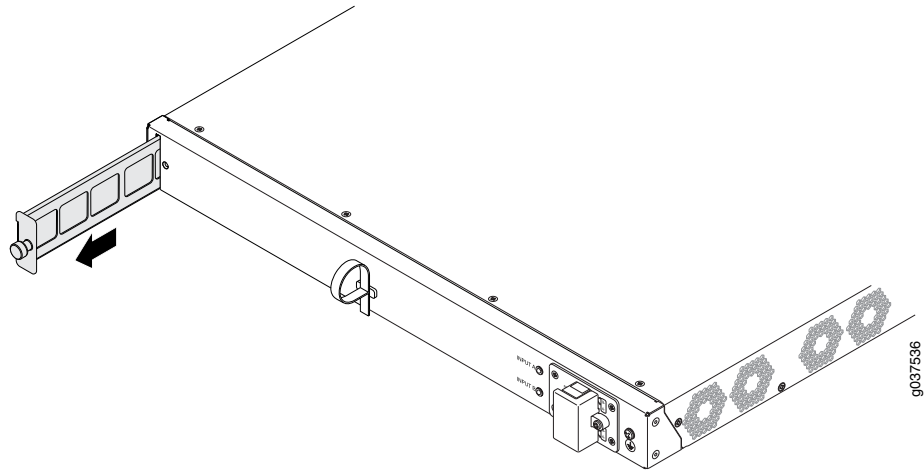

4. Slide the air filter straight into the chassis until it stops. See [Figure 21 on page 92](#).

Figure 21: Installing the Air Filter in a Services Gateway

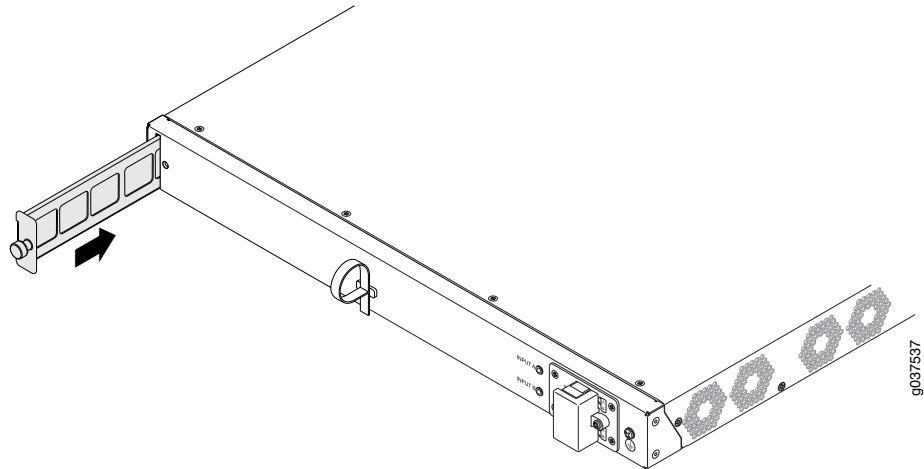

5. Tighten the screw on the air filter to secure it in the chassis. See [Figure 22 on page 92](#).

Figure 22: Tightening the Air Filter Screw

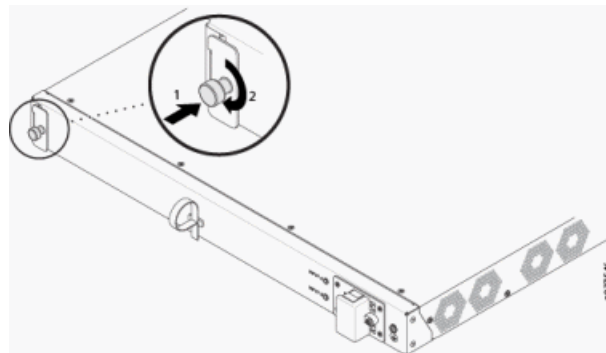



NOTE: When you are inserting an air filter for the first time on the SRX240 Services Gateway High Memory with AC Power supply model, you must remove the air filter cover by removing the screw on the cover using a number-1 Phillips screwdriver.

**Related
Documentation**

- [Maintaining the SRX240 Services Gateway Hardware Components on page 89](#)
- [SRX240 Services Gateway Air Filter on page 21](#)

Monitoring the SRX240 Services Gateway

This chapter includes the following topics:

- [Monitoring Hardware Components on the SRX240 Services Gateway on page 95](#)
- [Resetting the Configuration File When the SRX240 Services Gateway Is Inaccessible on page 105](#)
- [Juniper Networks Technical Assistance Center on page 106](#)

Monitoring Hardware Components on the SRX240 Services Gateway

This topic includes the following sections:

- [Monitoring the SRX240 Services Gateway Chassis Using the CLI on page 95](#)
- [Monitoring the SRX240 Services Gateway Components Using LEDs on page 97](#)
- [Monitoring the SRX240 Services Gateway Using Chassis Alarm Conditions on page 101](#)
- [Monitoring the SRX240 Services Gateway Power System on page 103](#)

Monitoring the SRX240 Services Gateway Chassis Using the CLI

You can monitor alarms to troubleshoot hardware problems on a services gateway. The chassis properties include the status of active chassis alarms on the services gateway, environment measurements, and the status of Mini-PIMs on the services gateway.

To view these chassis properties, select **Monitor>Chassis** in the J-Web interface, or enter the following CLI **show** commands:

- **show chassis hardware**
- **show chassis environment**
- **show chassis fpc**
- **show chassis alarms**

Examples:

The following examples provide the sample output of show CLI commands:

- **show chassis hardware** command
`user@host > show chassis hardware`

Hardware inventory:

Item	Version	Part number	Serial number	Description
Chassis			AG1111AA7943	SRX240h
Routing Engine	REV 01	750-021793	PW7943	RE-SRX240H
FPC 0				FPC
PIC 0				16x GE Base PIC
FPC 4				FPC
PIC 0				1x DOCSIS mPIM
Power Supply 0				

user@host > show chassis hardware detail

Hardware inventory:

Item	Version	Part number	Serial number	Description
Chassis			AG1111AA7943	SRX240h
Routing Engine	REV 01	750-021793	PW7943	RE-SRX240H
da0	999 MB	ST72682		Nand Flash
usb0 (addr 1)	DWC OTG root hub 0		vendor 0x0000	uhub0
usb0 (addr 2)	product 0x6254 25172		vendor 0x058f	uhub1
usb0 (addr 3)	ST72682 High Speed Mode	64218	STMicroelectronics	umass0
FPC 0				FPC
PIC 0				16x GE Base PIC
FPC 4				FPC
PIC 0				1x DOCSIS mPIM
Power Supply 0				



NOTE: The values given in the `usb0` rows provide information for USB level debugging. This information is about USB hub topology.

- **show chassis environment** command

Class	Item	Status	Measurement
Temp	Routing Engine	OK	36 degrees C / 96 degrees F
	Routing Engine CPU	Absent	
Fans	SRX240 Chassis fan 0	OK	Spinning at high speed
	SRX240 Chassis fan 1	OK	Spinning at high speed
Power	Power Supply 0	OK	

- **show chassis fpc** command

user@host > show chassis fpc

Slot	State	Temp (C)	CPU Utilization (%) Total	Interrupt	Memory DRAM (MB)	Utilization (%) Heap	Buffer
0	Online	-----	CPU less	FPC	-----		
1	Online	-----	CPU less	FPC	-----		
2	Online	-----	CPU less	FPC	-----		
3	Online	-----	CPU less	FPC	-----		
4	Online	-----	CPU less	FPC	-----		

- **show chassis alarms** command

user@host > show chassis alarms

1 alarms currently active

Alarm time	Class	Description
2010-01-04 17:11:06 UTC	Minor	Host 0 Boot firmware requires upgrade

For more information, see the following guides:

- [Initial Configuration for Security Devices](#)
- [Monitoring and Troubleshooting for Security Devices](#)

Related Documentation

- [Monitoring the SRX240 Services Gateway Components Using LEDs on page 97](#)
- [Monitoring the SRX240 Services Gateway Using Chassis Alarm Conditions on page 101](#)
- [Monitoring the SRX240 Services Gateway Power System on page 103](#)

Monitoring the SRX240 Services Gateway Components Using LEDs

The LEDs on the services gateway display the status of various components. [Table 32 on page 97](#) describes the LEDs.

Table 32: Component LEDs on the SRX240 Services Gateway

LED	State	Meaning	Possible Causes and Corrective Actions
Status LED	Green	The services gateway is functioning normally.	Normal condition. No action is required.
	Yellow	<ul style="list-style-type: none"> • The services gateway is starting up. • The RESET CONFIG button is pressed. 	Normal condition. No action is required.
	Red	An error is detected in the services gateway.	Contact the Juniper Networks Technical Assistance Center (JTAC). See “Juniper Networks Technical Assistance Center” on page 106 .

Table 32: Component LEDs on the SRX240 Services Gateway (*continued*)

LED	State	Meaning	Possible Causes and Corrective Actions
Alarm LED	Red	The services gateway detects a major alarm.	A major alarm indicates a critical situation on the gateway that requires immediate action. See "Monitoring the SRX240 Services Gateway Using Chassis Alarm Conditions" on page 101.
	Yellow	Indicates a minor alarm. NOTE: The Alarm LED glows Yellow while initializing.	A minor alarm requires monitoring or maintenance. If left unchecked, it might cause an interruption in service or degradation in performance. See "Monitoring the SRX240 Services Gateway Using Chassis Alarm Conditions" on page 101.
	Off	The services gateway is starting up. NOTE: When the system is up and running, if the Alarm LED is off, it indicates that no alarms are active on the services gateway.	Normal condition. No action is required.
Power LED	Green	The services gateway is receiving power supply and is functioning normally.	Normal condition. No action is required.
	Amber	The Power button has been pressed and quickly released.	Normal condition. No action is required.
	Off	The services gateway is not receiving power.	Normal condition if the services gateway is switched off. No action is required. If you have not powered off the services gateway, verify that the AC power cord from the power source to the device is not damaged, the socket is in working condition, and the device has an AC input voltage between 110 and 240 VAC. See "Monitoring the SRX240 Services Gateway Power System" on page 103.

Table 32: Component LEDs on the SRX240 Services Gateway (*continued*)

LED	State	Meaning	Possible Causes and Corrective Actions
HA LED	Off		The device is not part of the chassis cluster setup.
Mini-PIM LED	Green	The Mini-PIM is present and detected by the device.	Normal condition. No action is required.
	Off	The Mini-PIM is not present or is not detected by the device.	See “Monitoring the SRX240 Services Gateway Using Chassis Alarm Conditions” on page 101.

Table 32: Component LEDs on the SRX240 Services Gateway (*continued*)

LED	State	Meaning	Possible Causes and Corrective Actions
DC Power System Feeds LEDs	Green	Output is normal.	Normal condition. No action is required.
	Red (blinking)	The port has detected a failure.	<p>Input is connected but has failed because the power supply fuse has failed or the input voltage is low.</p> <ul style="list-style-type: none"> Verify that the source circuit breaker has the proper current rating. Each power supply must be connected to a separate source circuit breaker. Check whether the DC power cables from the power source to the device are not damaged. If the insulation is cracked or broken, immediately replace the cable. Contact the Juniper Networks Technical Assistance Center (JTAC). See "Juniper Networks Technical Assistance Center" on page 106.
	Red (steady)	The port has detected a failure.	<p>Both inputs are normal but no output because of output side failure or open connection.</p> <ul style="list-style-type: none"> Connect the power supply feeds to a different power source with a new power cables. Contact the Juniper Networks Technical Assistance Center (JTAC). See "Juniper Networks Technical Assistance Center" on page 106.
Off	No output		Normal condition if the services gateway is switched off. No action is required.

- Related Documentation**
- [Monitoring the SRX240 Services Gateway Chassis Using the CLI on page 95](#)
 - [Monitoring the SRX240 Services Gateway Using Chassis Alarm Conditions on page 101](#)
 - [Monitoring the SRX240 Services Gateway Power System on page 103](#)
 - [Loading the Rescue Configuration on the SRX240 Services Gateway on page 105](#)
 - [Changing the Reset Config Button Behavior on the SRX240 Services Gateway on page 106](#)
 - [Juniper Networks Technical Assistance Center on page 106](#)

Monitoring the SRX240 Services Gateway Using Chassis Alarm Conditions

When the services gateway detects an alarm condition, the Alarm LED on the front panel turns red or yellow as appropriate.

To view a more detailed description of the cause of the alarm, issue the **show chassis alarms** CLI command.

For more information about the **show chassis alarms** command, see the following guides:

- [Initial Configuration for Security Devices](#)
- [Monitoring and Troubleshooting for Security Devices](#)

Table 33 on page 101 describes the chassis alarm conditions and corrective actions.

Table 33: SRX240 Services Gateway Chassis Alarm Conditions and Corrective Actions

Component	Alarm Condition	Action	Alarm Severity
Boot media	The services gateway boots from an alternate boot device.	<ul style="list-style-type: none"> • If the internal flash memory fails at startup, the services gateway automatically boots itself from the alternative boot device (USB storage device). <p>NOTE: If you configured your services gateway to boot from an alternative boot device, ignore this alarm condition.</p> <ul style="list-style-type: none"> • Reformat the internal flash memory and install a bootable image. (See the Initial Configuration for Security Devices.) • If you did not configure the services gateway to boot from an alternative boot device, contact Juniper Networks Technical Assistance Center (JTAC). See "Juniper Networks Technical Assistance Center" on page 106. 	Yellow (minor)

Table 33: SRX240 Services Gateway Chassis Alarm Conditions and Corrective Actions (continued)

Component	Alarm Condition	Action	Alarm Severity
Mini-Physical Interface Module (Mini-PIM)	A Mini-PIM has failed.	<ul style="list-style-type: none"> Contact JTAC. See “Juniper Networks Technical Assistance Center” on page 106. If you must replace the failed Mini-PIM, see the SRX Series Services Gateways for the Branch Physical Interface Modules Hardware Guide for information about replacing the Mini-PIMs. 	Red (major)
Hardware components on the services gateway	The services gateway chassis temperature is too warm.	<ul style="list-style-type: none"> Check the room temperature. See “SRX240 Services Gateway Chassis” on page 7. Check the air flow. See “General Site Guidelines for Installing the SRX240 Services Gateway” on page 32. Check the fans. See “SRX240 Services Gateway Cooling System” on page 21. Contact JTAC for support. See “Juniper Networks Technical Assistance Center” on page 106. 	Yellow (minor)
	The services gateway fan has failed.	<ul style="list-style-type: none"> Use the CLI command show chassis environment to determine whether the fan is functioning normally. If fan has failed, contact JTAC for support. See “Juniper Networks Technical Assistance Center” on page 106. 	Red (major)
	The services gateway temperature is too high, either because of an internal overheating condition or because the maximum recommended room temperature has been exceeded.	The services gateway shuts down automatically in 4 minutes.	Red (major)

Related Documentation

- [Monitoring the SRX240 Services Gateway Chassis Using the CLI](#) on page 95
- [Monitoring the SRX240 Services Gateway Components Using LEDs](#) on page 97
- [Monitoring the SRX240 Services Gateway Power System](#) on page 103
- [Juniper Networks Technical Assistance Center](#) on page 106
- [SRX240 Services Gateway Chassis](#) on page 7
- [Clearance Requirements for Airflow and Hardware Maintenance on the SRX240 Services Gateway](#) on page 34

- [SRX240 Services Gateway Cooling System on page 21](#)

Monitoring the SRX240 Services Gateway Power System

This topic includes the following sections:

- [Monitoring the SRX240 Services Gateway AC Power System on page 103](#)
- [Monitoring the SRX240 Services Gateway DC Power System on page 104](#)

Monitoring the SRX240 Services Gateway AC Power System

The LEDs on the SRX240 Services Gateway enable you to determine its performance and operation. The Power LED, located on the front panel of the services gateway, indicates different conditions with respect to the power system.

[Table 34 on page 103](#) describes different Power LED indications and the required corrective actions.

Table 34: Services Gateway Power LED Status

LED Status	Meaning	Possible Cause and Corrective Action
Green	The services gateway is receiving power, and the internal power supply is functional.	Normal indication. No action is required.
Yellow	The Power button has been pressed and quickly released. The services gateway is shutting down or starting up.	Normal indication. No action is required.
Off	The services gateway is not receiving power.	<ul style="list-style-type: none"> • Verify that the AC power cord from the power source to the services gateway is not damaged. If the insulation is cracked or broken, immediately replace the cord or cable. • Ensure that the socket you plug in is in working condition. • Ensure the services gateway has an AC input voltage between 110 and 240 VAC. • If you cannot determine the cause of the problem or need additional assistance, contact the Juniper Networks Technical Assistance Center (JTAC). <p>See “Juniper Networks Technical Assistance Center” on page 106.</p>

Monitoring the SRX240 Services Gateway DC Power System

The back panel of an SRX240 Services Gateway with DC power supply model has two LEDs that indicate the status of the dual feed for the integrated DC power supply.

[Table 35 on page 104](#) describes the LEDs on the DC power feeds on the SRX240 Services Gateway DC power supply model.

Table 35: SRX240 Services Gateway DC Power Feed LEDs

DC Input		DC Output	LED A	LED B
Input A	Input B			
Input is normal.	Input is normal.	No output ¹ .	Red	Red
		Output is normal.	Green	Green
Input is connected but has failed because the power supply fuse has failed or input voltage is low.	Input is normal.	Output is normal.	Red (blinking)	Green
Input is normal.	Input is connected but has failed because the power supply fuse has failed or input voltage is low.	Output is normal.	Green	Red (blinking)
Input breaker open or no DC input connected.	Input is normal.	Output is normal.	Red (blinking)	Green
Input has failed.	Input has failed.	No output.	Red (blinking)	Red (blinking)
No input.	No input.	No output.	Off	Off

(1) No output because of output side failure or open connection.

Related Documentation

- [Monitoring the SRX240 Services Gateway Chassis Using the CLI on page 95](#)
- [Monitoring the SRX240 Services Gateway Components Using LEDs on page 97](#)
- [Monitoring the SRX240 Services Gateway Using Chassis Alarm Conditions on page 101](#)
- [Juniper Networks Technical Assistance Center on page 106](#)
- [SRX240 Services Gateway LEDs on page 14](#)

Resetting the Configuration File When the SRX240 Services Gateway Is Inaccessible

You can use the SRX240 Services Gateway's RESET CONFIG button to restore the device's configuration file when the current one is faulty or fails. You can also change the default behavior of the RESET CONFIG button.

This topic includes the following sections:

- [Loading the Rescue Configuration on the SRX240 Services Gateway on page 105](#)
- [Changing the Reset Config Button Behavior on the SRX240 Services Gateway on page 106](#)

Loading the Rescue Configuration on the SRX240 Services Gateway

If a configuration fails or denies management access to the services gateway, you can use the RESET CONFIG button to restore the device to the factory-default configuration or a rescue configuration. For example, if someone inadvertently commits a configuration that denies management access to a services gateway, you can delete the invalid configuration and replace it with a rescue configuration by pressing the RESET CONFIG button.



NOTE: The RESET CONFIG button is recessed to prevent it from being pressed accidentally.

The rescue configuration is a previously committed, valid configuration. You must have previously set the rescue configuration through the J-Web interface or the CLI.

To press the RESET CONFIG button, insert a small probe (such as a straightened paper clip) into the pinhole on the front panel.

- By default, pressing and quickly releasing the RESET CONFIG button loads and commits the rescue configuration through the J-Web interface or the CLI. The Status LED is solid amber during this time.
- By default, pressing and holding the RESET CONFIG button for 15 seconds or more—until the Status LED is solid amber — deletes all configurations on the device, including the backup configurations and rescue configuration, and loads and commits the factory configuration.

For details about factory-default settings, see the following topics:

- [Initial Configuration for Security Devices](#)
- [Monitoring and Troubleshooting for Security Devices](#)

Related Documentation

- [Changing the Reset Config Button Behavior on the SRX240 Services Gateway on page 106](#)
- [Monitoring the SRX240 Services Gateway Chassis Using the CLI on page 95](#)

- [Monitoring the SRX240 Services Gateway Components Using LEDs on page 97](#)
- [SRX240 Services Gateway LEDs on page 14](#)

Changing the Reset Config Button Behavior on the SRX240 Services Gateway

You can change the default operation of the RESET CONFIG button by limiting how the button resets the services gateway:

- To prevent the RESET CONFIG button from setting the device to the factory-default configuration and deleting all other configurations:

```
admin@host# set chassis config-button no-clear
```

You can still press and quickly release the button to reset it to the rescue configuration.

- To prevent the RESET CONFIG button from setting the device to the rescue configuration:

```
admin@host# set chassis config-button no-rescue
```

You can still press and hold the button for 15 seconds or more to reset the gateway to the factory-default configuration.

- To disable the button and prevent the device from resetting to either configuration:

```
admin@host# set chassis config-button no-clear no-rescue
```

The **no-clear** option prevents the RESET CONFIG button from deleting all configurations on the services gateway. The **no-rescue** option prevents the RESET CONFIG button from loading the rescue configuration.

To return the function of the RESET CONFIG button to its default behavior, remove the **config-button** statement from the device configuration.

Related Documentation

- [Monitoring the SRX240 Services Gateway Chassis Using the CLI on page 95](#)
- [Monitoring the SRX240 Services Gateway Components Using LEDs on page 97](#)
- [SRX240 Services Gateway LEDs on page 14](#)
- [Loading the Rescue Configuration on the SRX240 Services Gateway on page 105](#)

Juniper Networks Technical Assistance Center

If you need assistance while troubleshooting a services gateway, open a support case using the Case Manager link at <http://www.juniper.net/support/>, or call 1-888-314-JTAC (within the United States) or 1-408-745-9500 (from outside the United States).

Related Documentation

- [Information You Might Need to Supply to Juniper Networks Technical Assistance Center on page 156](#)

PART 4

Appendixes

- [Safety and Regulatory Compliance Information on page 109](#)
- [SRX240 Services Gateway Power Guidelines, Requirements, and Specifications on page 143](#)
- [SRX240 Services Gateway Interface Cable Specifications and Connector Pinouts on page 149](#)
- [Contacting Customer Support and Returning the SRX240 Services Gateway Hardware on page 153](#)

APPENDIX A

Safety and Regulatory Compliance Information

This appendix includes the following topics:

- SRX240 Services Gateway Definition of Safety Warning Levels on page 109
- SRX240 Services Gateway General Safety Guidelines and Warnings on page 111
- SRX240 Services Gateway Fire Safety Requirements on page 115
- SRX240 Services Gateway Installation Safety Guidelines and Warnings on page 116
- SRX240 Services Gateway Laser and LED Safety Guidelines and Warnings on page 121
- SRX240 Services Gateway Maintenance and Operational Safety Guidelines and Warnings on page 125
- SRX240 Services Gateway Electrical Safety Guidelines and Warnings on page 130
- DC Power Electrical Safety Guidelines and Warnings on page 132
- SRX240 Services Gateway Agency Approvals on page 138
- SRX240 Services Gateway Compliance Statements for EMC Requirements on page 139
- SRX240 Services Gateway (DC Power Supply Model) Compliance Statements for Network Equipment Building System (NEBS) on page 140
- SRX240 Services Gateway Compliance Statements for Environmental Requirements on page 140
- SRX240 Services Gateway Compliance Statements for Acoustic Noise on page 141

SRX240 Services Gateway Definition of Safety Warning Levels

This topic defines the following four levels of safety warnings used in Juniper Networks technical publications:



NOTE: You might find this information helpful in a particular situation or might otherwise overlook it.



CAUTION: You need to observe the specified guidelines to avoid minor injury or discomfort to you or severe damage to the services gateway.



WARNING: This symbol is used with laser warnings. Unterminated optical connectors can emit invisible laser radiation. Focusing your eye directly on a laser source—even a low-power laser—could permanently damage the eye.



WARNING: This symbol means danger. You are in a situation that could cause bodily injury. Before you work on any equipment, be aware of the hazards involved with electrical circuitry and be familiar with standard practices for preventing accidents.

Waarschuwing Dit waarschuwingssymbool betekent gevaar. U verkeert in een situatie die lichamelijk letsel kan veroorzaken. Voordat u aan enige apparatuur gaat werken, dient u zich bewust te zijn van de bij elektrische schakelingen betrokken risico's en dient u op de hoogte te zijn van standaard maatregelen om ongelukken te voorkomen.

Varoitus Tämä varoitusmerkki merkitsee vaaraa. Olet tilanteessa, joka voi johtaa ruumiinvammaan. Ennen kuin työskentelet minkään laitteiston parissa, ota selvää sähkökytkentöihin liittyvistä vaaroista ja tavanomaisista onnettomuuksien ehkäisykeinoista.

Attention Ce symbole d'avertissement indique un danger. Vous vous trouvez dans une situation pouvant causer des blessures ou des dommages corporels. Avant de travailler sur un équipement, soyez conscient des dangers posés par les circuits électriques et familiarisez-vous avec les procédures couramment utilisées pour éviter les accidents.

Warnung Dieses Warnsymbol bedeutet Gefahr. Sie befinden sich in einer Situation, die zu einer Körperverletzung führen könnte. Bevor Sie mit der Arbeit an irgendeinem Gerät beginnen, seien Sie sich der mit elektrischen Stromkreisen verbundenen Gefahren und der Standardpraktiken zur Vermeidung von Unfällen bewußt.

Avvertenza Questo simbolo di avvertenza indica un pericolo. La situazione potrebbe causare infortuni alle persone. Prima di lavorare su qualsiasi apparecchiatura, occorre conoscere i pericoli relativi ai circuiti elettrici ed essere al corrente delle pratiche standard per la prevenzione di incidenti.

Advarsel Dette varselsymbolet betyr fare. Du befinner deg i en situasjon som kan føre til personskade. Før du utfører arbeid på utstyr, må du være oppmerksom på de faremomentene som elektriske kretser innebærer, samt gjøre deg kjent med vanlig praksis når det gjelder å unngå ulykker.

Aviso Este símbolo de aviso indica perigo. Encontra-se numa situação que lhe poderá causar danos físicos. Antes de começar a trabalhar com qualquer equipamento, familiarize-se com os perigos relacionados com circuitos eléctricos, e com quaisquer práticas comuns que possam prevenir possíveis acidentes.

¡Atención! Este símbolo de aviso significa peligro. Existe riesgo para su integridad física. Antes de manipular cualquier equipo, considerar los riesgos que entraña la corriente eléctrica y familiarizarse con los procedimientos estándar de prevención de accidentes.

Varning! Denna varningssymbol signalerar fara. Du befinner dig i en situation som kan leda till personskada. Innan du utför arbete på någon utrustning måste du vara medveten om farorna med elkretsar och känna till vanligt förfarande för att förebygga skador.

**Related
Documentation**

- [SRX240 Services Gateway General Safety Guidelines and Warnings on page 111](#)
- [SRX240 Services Gateway Fire Safety Requirements on page 115](#)
- [SRX240 Services Gateway Installation Safety Guidelines and Warnings on page 116](#)
- [SRX240 Services Gateway Laser and LED Safety Guidelines and Warnings on page 121](#)
- [SRX240 Services Gateway Maintenance and Operational Safety Guidelines and Warnings on page 125](#)
- [SRX240 Services Gateway Electrical Safety Guidelines and Warnings on page 130](#)

[SRX240 Services Gateway General Safety Guidelines and Warnings](#)

This topic includes the following sections:

- [General Safety Guidelines and Warnings on page 111](#)
- [Qualified Personnel Warning on page 112](#)
- [Restricted Access Area Warning on page 113](#)
- [Preventing Electrostatic Discharge Damage to the Services Gateway on page 114](#)

General Safety Guidelines and Warnings

The following guidelines help ensure your safety and protect the services gateway from damage. The list of guidelines might not address all potentially hazardous situations in your working environment, so it is important that you remain alert and exercise good judgment at all times.

- Perform only the procedures explicitly described in these topics. Ensure that only authorized service personnel perform other system services.
- Keep the area around the chassis clear and free from dust before, during, and after installation.

- Keep tools away from areas where people could trip on them.
- Wear safety glasses if you are working under any conditions that could be hazardous to your eyes.
- Do not perform any actions that create a potential hazard to people or make the equipment unsafe.
- Never install or manipulate wiring during electrical storms.
- Never install electrical jacks in wet locations unless the jacks are specifically designed for wet environments.
- Do not open or remove chassis covers or sheet metal parts unless instructions are provided in this guide. Such an action could cause severe electrical shock.
- Do not push or force any objects through any opening in the chassis frame. Such an action could result in electrical shock or fire.
- Avoid spilling liquid onto the services gateway chassis or onto any services gateway component. Such an action could cause electrical shock or damage the services gateway.
- Avoid touching uninsulated electrical wires or terminals that have not been disconnected from their power source. Such an action could cause electrical shock.

Qualified Personnel Warning



WARNING: Only trained and qualified personnel should install or replace the services gateway.

Waarschuwing Installatie en reparaties mogen uitsluitend door getraind en bevoegd personeel uitgevoerd worden.

Varoitus Ainoastaan koulutettu ja pätevä henkilökunta saa asentaa tai vaihtaa tämän laitteen.

Attention Tout installation ou remplacement de l'appareil doit être réalisé par du personnel qualifié et compétent.

Warnung Gerät nur von geschultem, qualifiziertem Personal installieren oder auswechseln lassen.

Avvertenza Solo personale addestrato e qualificato deve essere autorizzato ad installare o sostituire questo apparecchio.

Advarsel Kun kvalifisert personell med riktig opplæring bør montere eller bytte ut dette utstyret.

Aviso Este equipamento deverá ser instalado ou substituído apenas por pessoal devidamente treinado e qualificado.

¡Atención! Estos equipos deben ser instalados y reemplazados exclusivamente por personal técnico adecuadamente preparado y capacitado.

Varning! Denna utrustning ska endast installeras och bytas ut av utbildad och kvalificerad personal.

Restricted Access Area Warning



WARNING: The services gateway is intended for installation in restricted access areas. A restricted access area is an area to which access can be gained only by service personnel through the use of a special tool, lock and key, or other means of security, and which is controlled by the authority responsible for the location.

Waarschuwing Dit toestel is bedoeld voor installatie op plaatsen met beperkte toegang. Een plaats met beperkte toegang is een plaats waar toegang slechts door servicepersoneel verkregen kan worden door middel van een speciaal instrument, een slot en sleutel, of een ander veiligheidsmiddel, en welke beheerd wordt door de overheidsinstantie die verantwoordelijk is voor de locatie.

Varoitus Tämä laite on tarkoitettu asennettavaksi paikkaan, johon pääsy on rajoitettua. Paikka, johon pääsy on rajoitettua, tarkoittaa paikkaa, johon vain huoltohenkilöstö pääsee jonkin erikoistyökalun, lukkoon sopivan avaimen tai jonkin muun turvalaitteen avulla ja joka on paikasta vastuussa olevien toimivaltaisten henkilöiden valvoma.

Attention Cet appareil est à installer dans des zones d'accès réservé. Ces dernières sont des zones auxquelles seul le personnel de service peut accéder en utilisant un outil spécial, un mécanisme de verrouillage et une clé, ou tout autre moyen de sécurité. L'accès aux zones de sécurité est sous le contrôle de l'autorité responsable de l'emplacement.

Warnung Diese Einheit ist zur Installation in Bereichen mit beschränktem Zutritt vorgesehen. Ein Bereich mit beschränktem Zutritt ist ein Bereich, zu dem nur Wartungspersonal mit einem Spezialwerkzeugs, Schloß und Schlüssel oder anderer Sicherheitsvorkehrungen Zugang hat, und der von dem für die Anlage zuständigen Gremium kontrolliert wird.

Avvertenza Questa unità deve essere installata in un'area ad accesso limitato. Un'area ad accesso limitato è un'area accessibile solo a personale di assistenza tramite un'attrezzo speciale, lucchetto, o altri dispositivi di sicurezza, ed è controllata dall'autorità responsabile della zona.

Advarsel Denne enheten er laget for installasjon i områder med begrenset adgang. Et område med begrenset adgang gir kun adgang til servicepersonale som bruker et spesielt verktøy, lås og nøkkel, eller en annen sikkerhetsanordning, og det kontrolleres av den autoriteten som er ansvarlig for området.

Aviso Esta unidade foi concebida para instalação em áreas de acesso restrito. Uma área de acesso restrito é uma área à qual apenas tem acesso o pessoal de serviço autorizado, que possua uma ferramenta, chave e fechadura especial, ou qualquer outra forma de segurança. Esta área é controlada pela autoridade responsável pelo local.

¡Atención! Esta unidad ha sido diseñada para instalarse en áreas de acceso restringido. Área de acceso restringido significa un área a la que solamente tiene acceso el personal de servicio mediante la utilización de una herramienta especial, cerradura con llave, o algún otro medio de seguridad, y que está bajo el control de la autoridad responsable del local.

Varning! Denna enhet är avsedd för installation i områden med begränsat tillträde. Ett område med begränsat tillträde får endast tillträdas av servicepersonal med ett speciellt verktyg, lås och nyckel, eller annan säkerhetsanordning, och kontrolleras av den auktoritet som ansvarar för området.

Preventing Electrostatic Discharge Damage to the Services Gateway

Many services gateway hardware components are sensitive to damage from static electricity. Some components can be impaired by voltages as low as 30 V. You can easily generate potentially damaging static voltages whenever you handle plastic or foam packing material or if you move components across plastic or carpets. Observe the following guidelines to minimize the potential for electrostatic discharge (ESD) damage, which can cause intermittent or complete component failures:

- Always use an ESD wrist strap or ankle strap, and verify that it is in direct contact with your skin.



CAUTION: For safety, periodically check the resistance value of the ESD strap. The measurement should be in the range of 1 to 10 Mohms.

-
- When handling any component that is removed from the chassis, verify that the equipment end of your ESD strap is attached to one of the ESD points on the chassis.
 - Avoid contact between the component and your clothing. ESD voltages emitted from clothing can still damage components.
 - When removing or installing a component, always place it component-side up on an antistatic surface, in an antistatic card rack, or in an electrostatic bag. If you are returning a component, place it into an electrostatic bag before packing it. See [Figure 23 on page 115](#).

Figure 23: Placing a Component into an Electrostatic Bag

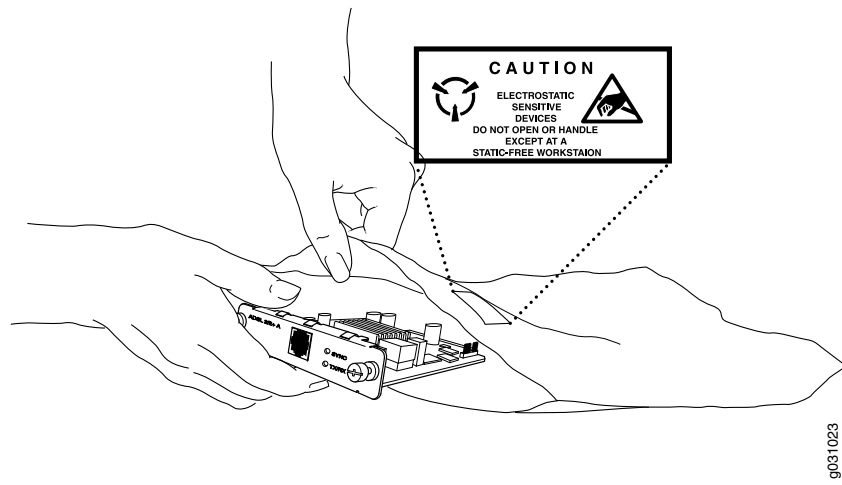

Related Documentation

- [SRX240 Services Gateway Definition of Safety Warning Levels on page 109](#)
- [SRX240 Services Gateway Fire Safety Requirements on page 115](#)
- [SRX240 Services Gateway Installation Safety Guidelines and Warnings on page 116](#)
- [SRX240 Services Gateway Laser and LED Safety Guidelines and Warnings on page 121](#)
- [SRX240 Services Gateway Maintenance and Operational Safety Guidelines and Warnings on page 125](#)
- [SRX240 Services Gateway Electrical Safety Guidelines and Warnings on page 130](#)

SRX240 Services Gateway Fire Safety Requirements

In the event of a fire emergency involving devices and other network equipment, the safety of people is the primary concern. Establish procedures for protecting people in the event of a fire emergency, provide safety training, and properly provision fire-control equipment and fire extinguishers.

In addition, establish procedures to protect your equipment in the event of a fire emergency. Juniper Networks products should be installed in an environment suitable for electronic equipment. We recommend that fire suppression equipment be available in the event of a fire in the vicinity of the equipment and that all local fire, safety, and electrical codes and ordinances be observed when installing and operating your equipment.

In the event of an electrical hazard or an electrical fire, first turn power off to the equipment at the source. Then use a Type C fire extinguisher to extinguish the fire. Type C fire extinguishers, which use noncorrosive fire retardants such as carbon dioxide (CO₂) and Halotron, are most effective for suppressing electrical fires. Type C fire extinguishers displace the oxygen from the point of combustion to eliminate the fire. For extinguishing fire on or around equipment that draws air from the environment for cooling, use this

type of inert oxygen displacement extinguisher instead of an extinguisher that leaves residue on equipment.

Do not use multipurpose Type ABC chemical fire extinguishers (dry chemical fire extinguishers) near Juniper Networks equipment. The primary ingredient in these fire extinguishers is monoammonium phosphate, which is very sticky and difficult to clean. In addition, in minute amounts of moisture, monoammonium phosphate can become highly corrosive and corrodes most metals.

Any equipment in a room in which a chemical fire extinguisher has been discharged is subject to premature failure and unreliable operation. The equipment is considered to be irreparably damaged.



NOTE: To keep warranties effective, do not use a dry chemical fire extinguisher to control a fire at or near a Juniper Networks services gateway. If a dry chemical fire extinguisher is used, the unit is no longer eligible for coverage under a service agreement.

We recommend that you dispose of any irreparably damaged equipment in an environmentally responsible manner.

Related Documentation

- [SRX240 Services Gateway Definition of Safety Warning Levels on page 109](#)
- [SRX240 Services Gateway General Safety Guidelines and Warnings on page 111](#)
- [SRX240 Services Gateway Installation Safety Guidelines and Warnings on page 116](#)
- [SRX240 Services Gateway Laser and LED Safety Guidelines and Warnings on page 121](#)
- [SRX240 Services Gateway Maintenance and Operational Safety Guidelines and Warnings on page 125](#)
- [SRX240 Services Gateway Electrical Safety Guidelines and Warnings on page 130](#)

SRX240 Services Gateway Installation Safety Guidelines and Warnings

This topic includes the following sections:

- [Installation Instructions Warning on page 116](#)
- [Rack-Mounting Requirements and Warnings on page 118](#)

Installation Instructions Warning



NOTE: The SRX240 Services Gateway can be installed as customer premises equipment (CPE) only.



WARNING: Read the installation instructions before you connect the services gateway to a power source.

Waarschuwing Raadpleeg de installatie-aanwijzingen voordat u het systeem met de voeding verbindt.

Varoitus Lue asennusohjeet ennen järjestelmän yhdistämistä virtalähteeseen.

Attention Avant de brancher le système sur la source d'alimentation, consulter les directives d'installation.

Warnung Lesen Sie die Installationsanweisungen, bevor Sie das System an die Stromquelle anschließen.

Avvertenza Consultare le istruzioni di installazione prima di collegare il sistema all'alimentatore.

Advarsel Les installasjonsinstruksjonene før systemet kobles til strømkilden.

Aviso Leia as instruções de instalação antes de ligar o sistema à sua fonte de energia.

¡Atención! Ver las instrucciones de instalación antes de conectar el sistema a la red de alimentación.

Varning! Läs installationsanvisningarna innan du kopplar systemet till dess strömförsörjningsenhet.



WARNING: Before you make any crimp connections, coat all conductors (frame ground, battery, and battery return) with an appropriate antioxidant compound. Before you connect unplated connectors, braided strap, and bus bars, bring them to a bright finish and coat them with an antioxidant compound. You do not have to prepare tinned, solder-plated, or silver-plated connectors or other plated connection surfaces before connecting them, but make sure such surfaces remain clean and free of contaminants. To provide a permanent low-impedance path, tighten all raceway fittings.



WARNING: An electrical conducting path shall exist between the device chassis and the grounding conductor, or between the chassis and the metal surface of the enclosure or rack in which the device is mounted. Electrical continuity shall be provided by the use of thread-forming-type, unit-mounting screws that remove any paint or nonconductive coatings and establish metal-to-metal contact. Any paint or other nonconductive coatings shall be removed on the surfaces between the mounting hardware and the enclosure or rack. The surfaces shall be cleaned and an antioxidant applied before installation.

Rack-Mounting Requirements and Warnings

Ensure that the equipment rack into which the services gateway is installed is evenly and securely supported to avoid the hazardous condition that could result from uneven mechanical loading.



WARNING: To prevent bodily injury when mounting or servicing the services gateway in a rack, take the following precautions to ensure that the system remains stable. The following directives help maintain your safety:

- The services gateway must be installed into a rack that is secured to the building structure.
- The services gateway should be mounted at the bottom of the rack if it is the only unit in the rack.
- When mounting the services gateway in a partially filled rack, load the rack from the bottom to the top with the heaviest component at the bottom of the rack.
- If the rack is provided with stabilizing devices, install the stabilizers before mounting or servicing the services gateway in the rack.

Waarschuwing Om lichamelijk letsel te voorkomen wanneer u dit toestel in een rek monteert of het daar een servicebeurt geeft, moet u speciale voorzorgsmaatregelen nemen om ervoor te zorgen dat het toestel stabiel blijft. De onderstaande richtlijnen worden verstrekt om uw veiligheid te verzekeren:

- De Juniper Networks services gateway moet in een stelling worden geïnstalleerd die aan een bouwsel is verankerd.
- Dit toestel dient onderaan in het rek gemonteerd te worden als het toestel het enige in het rek is.
- Wanneer u dit toestel in een gedeeltelijk gevuld rek monteert, dient u het rek van onderen naar boven te laden met het zwaarste onderdeel onderaan in het rek.
- Als het rek voorzien is van stabiliseringshulpmiddelen, dient u de stabilisatoren te monteren voordat u het toestel in het rek monteert of het daar een servicebeurt geeft.

Varoitus Kun laite asetetaan telineeseen tai huolletaan sen ollessa telineessä, on noudatettava erityisiä varotoimia järjestelmän vakavuuden säilyttämiseksi, jotta vältetään loukkaantumiselta. Noudata seuraavia turvallisuusohjeita:

- Juniper Networks services gateway on asennettava telineeseen, joka on kiinnitetty rakennukseen.
- Jos telineessä ei ole muita laitteita, aseta laite telineen alaosaan.

- Jos laite asetetaan osaksi täytettyyn telineeseen, aloita kuormittaminen sen alaosasta kaikkein raskaimmalla esineellä ja siirry sitten sen yläosaan.
- Jos telinettä varten on vakaimet, asenna ne ennen laitteen asettamista telineeseen tai sen huoltamista siinä.

Attention Pour éviter toute blessure corporelle pendant les opérations de montage ou de réparation de cette unité en casier, il convient de prendre des précautions spéciales afin de maintenir la stabilité du système. Les directives ci-dessous sont destinées à assurer la protection du personnel:

- Le rack sur lequel est monté le Juniper Networks services gateway doit être fixé à la structure du bâtiment.
- Si cette unité constitue la seule unité montée en casier, elle doit être placée dans le bas.
- Si cette unité est montée dans un casier partiellement rempli, charger le casier de bas en haut en plaçant l'élément le plus lourd dans le bas.
- Si le casier est équipé de dispositifs stabilisateurs, installer les stabilisateurs avant de monter ou de réparer l'unité en casier.

Warnung Zur Vermeidung von Körperverletzung beim Anbringen oder Warten dieser Einheit in einem Gestell müssen Sie besondere Vorkehrungen treffen, um sicherzustellen, daß das System stabil bleibt. Die folgenden Richtlinien sollen zur Gewährleistung Ihrer Sicherheit dienen:

- Der Juniper Networks services gateway muß in einem Gestell installiert werden, das in der Gebäudestruktur verankert ist.
- Wenn diese Einheit die einzige im Gestell ist, sollte sie unten im Gestell angebracht werden.
- Bei Anbringung dieser Einheit in einem zum Teil gefüllten Gestell ist das Gestell von unten nach oben zu laden, wobei das schwerste Bauteil unten im Gestell anzubringen ist.
- Wird das Gestell mit Stabilisierungszubehör geliefert, sind zuerst die Stabilisatoren zu installieren, bevor Sie die Einheit im Gestell anbringen oder sie warten.

Avvertenza Per evitare infortuni fisici durante il montaggio o la manutenzione di questa unità in un supporto, occorre osservare speciali precauzioni per garantire che il sistema rimanga stabile. Le seguenti direttive vengono fornite per garantire la sicurezza personale:

- Il Juniper Networks services gateway deve essere installato in un telaio, il quale deve essere fissato alla struttura dell'edificio.
- Questa unità deve venire montata sul fondo del supporto, se si tratta dell'unica unità da montare nel supporto.

- Quando questa unità viene montata in un supporto parzialmente pieno, caricare il supporto dal basso all'alto, con il componente più pesante sistemato sul fondo del supporto.
- Se il supporto è dotato di dispositivi stabilizzanti, installare tali dispositivi prima di montare o di procedere alla manutenzione dell'unità nel supporto.

Advarsel Unngå fysiske skader under montering eller reparasjonsarbeid på denne enheten når den befinner seg i et kabinett. Vær nøye med at systemet er stabilt. Følgende retningslinjer er gitt for å verne om sikkerheten:

- Juniper Networks services gateway må installeres i et stativ som er forankret til bygningsstrukturen.
- Denne enheten bør monteres nederst i kabinettet hvis dette er den eneste enheten i kabinettet.
- Ved montering av denne enheten i et kabinett som er delvis fylt, skal kabinettet lastes fra bunnen og opp med den tyngste komponenten nederst i kabinettet.
- Hvis kabinettet er utstyrt med stabiliseringsutstyr, skal stabilisatorene installeres før montering eller utføring av reparasjonsarbeid på enheten i kabinettet.

Aviso Para se prevenir contra danos corporais ao montar ou reparar esta unidade numa estante, deverá tomar precauções especiais para se certificar de que o sistema possui um suporte estável. As seguintes directrizes ajudá-lo-ão a efectuar o seu trabalho com segurança:

- O Juniper Networks services gateway deverá ser instalado numa prateleira fixa à estrutura do edifício.
- Esta unidade deverá ser montada na parte inferior da estante, caso seja esta a única unidade a ser montada.
- Ao montar esta unidade numa estante parcialmente ocupada, coloque os itens mais pesados na parte inferior da estante, arrumando-os de baixo para cima.
- Se a estante possuir um dispositivo de estabilização, instale-o antes de montar ou reparar a unidade.

¡Atención! Para evitar lesiones durante el montaje de este equipo sobre un bastidor, o posteriormente durante su mantenimiento, se debe poner mucho cuidado en que el sistema quede bien estable. Para garantizar su seguridad, proceda según las siguientes instrucciones:

- El Juniper Networks services gateway debe instalarse en un bastidor fijado a la estructura del edificio.
- Colocar el equipo en la parte inferior del bastidor, cuando sea la única unidad en el mismo.

- Cuando este equipo se vaya a instalar en un bastidor parcialmente ocupado, comenzar la instalación desde la parte inferior hacia la superior colocando el equipo más pesado en la parte inferior.
- Si el bastidor dispone de dispositivos estabilizadores, instalar éstos antes de montar o proceder al mantenimiento del equipo instalado en el bastidor.

Varning! För att undvika kroppsskada när du installerar eller utför underhållsarbete på denna enhet på en ställning måste du vidta särskilda försiktighetsåtgärder för att försäkra dig om att systemet står stadigt. Följande riktlinjer ges för att trygga din säkerhet:

- Juniper Networks services gateway måste installeras i en ställning som är förankrad i byggnadens struktur.
- Om denna enhet är den enda enheten på ställningen skall den installeras längst ned på ställningen.
- Om denna enhet installeras på en delvis fylld ställning skall ställningen fyllas nedifrån och upp, med de tyngsta enheterna längst ned på ställningen.
- Om ställningen är försedd med stabiliseringsdon skall dessa monteras fast innan enheten installeras eller underhålls på ställningen.

**Related
Documentation**

- [SRX240 Services Gateway Definition of Safety Warning Levels on page 109](#)
- [SRX240 Services Gateway General Safety Guidelines and Warnings on page 111](#)
- [SRX240 Services Gateway Fire Safety Requirements on page 115](#)
- [SRX240 Services Gateway Laser and LED Safety Guidelines and Warnings on page 121](#)
- [SRX240 Services Gateway Maintenance and Operational Safety Guidelines and Warnings on page 125](#)
- [SRX240 Services Gateway Electrical Safety Guidelines and Warnings on page 130](#)

SRX240 Services Gateway Laser and LED Safety Guidelines and Warnings

The 1-Port SFP Mini-Physical Interface Module (Mini-PIM) is equipped with laser transmitters, which are considered a Class 1 Laser Product by the USA Food and Drug Administration, and they are evaluated as a Class 1 Laser Product per EN 60825-1 +A11 +A2 requirements.

This topic includes the following section:

- [Laser and LED Safety Guidelines and Warnings on page 122](#)

Laser and LED Safety Guidelines and Warnings

General Laser Safety Guidelines

When working around Mini-PIMs, observe the following safety guidelines to prevent eye injury:

- Do not look into unterminated ports or at fibers that connect to unknown sources.
- Do not examine unterminated optical ports with optical instruments.
- Avoid direct exposure to the beam.



WARNING: Unterminated optical connectors can emit invisible laser radiation. The lens in the human eye focuses all the laser power on the retina, so focusing the eye directly on a laser source—even a low-power laser—could permanently damage the eye.

Class 1 Laser Product Warning



WARNING: Class 1 laser product.

Waarschuwing Klasse-1 laser produkt.

Varoitus Luokan 1 lasertuote.

Attention Produit laser de classe I.

Warnung Laserprodukt der Klasse 1.

Avvertenza Prodotto laser di Classe 1.

Advarsel Laserprodukt av klasse 1.

Aviso Produto laser de classe 1.

¡Atención! Producto láser Clase I.

Varning! Laserprodukt av klass 1.

Class 1 LED Product Warning



WARNING: Class 1 LED product.

Waarschuwing Klasse 1 LED-product.

Varoitus Luokan 1 valodiodituote.

Attention Alarme de produit LED Class I.

Warnung Class 1 LED-Produktwarnung.

Avvertenza Avvertenza prodotto LED di Classe 1.

Advarsel LED-produkt i klasse 1.

Aviso Produto de classe 1 com LED.

¡Atención! Aviso sobre producto LED de Clase 1.

Varning! Lysdiodprodukt av klass 1.

Laser Beam Warning



WARNING: Do not stare into the laser beam or view it directly with optical instruments.

Waarschuwing Niet in de straal staren of hem rechtstreeks bekijken met optische instrumenten.

Varoitus Älä katso säteeseen äläkä tarkastele sitä suoraan optisen laitteen avulla.

Attention Ne pas fixer le faisceau des yeux, ni l'observer directement à l'aide d'instruments optiques.

Warnung Nicht direkt in den Strahl blicken und ihn nicht direkt mit optischen Geräten prüfen.

Avvertenza Non fissare il raggio con gli occhi né usare strumenti ottici per osservarlo direttamente.

Advarsel Stirr eller se ikke direkte på strålen med optiske instrumenter.

Aviso Não olhe fixamente para o raio, nem olhe para ele diretamente com instrumentos ópticos.

¡**Atención!** No mirar fijamente el haz ni observarlo directamente con instrumentos ópticos.

Varning! Rikta inte blicken in mot strålen och titta inte direkt på den genom optiska instrument.

Radiation from Open Port Apertures Warning



WARNING: Because invisible radiation may be emitted from the aperture of the port when no fiber cable is connected, avoid exposure to radiation and do not stare into open apertures.

Waarschuwing Aangezien onzichtbare straling vanuit de opening van de poort kan komen als er geen fiberkabel aangesloten is, dient blootstelling aan straling en het kijken in open openingen vermeden te worden.

Varoitus Koska portin aukosta voi emittoitua näkymätöntä säteilyä, kun kuitukaapelia ei ole kytkettynä, vältä säteilylle altistumista äläkä katso avoimiin aukkoihin.

Attention Des radiations invisibles à l'il nu pouvant traverser l'ouverture du port lorsqu'aucun câble en fibre optique n'y est connecté, il est recommandé de ne pas regarder fixement l'intérieur de ces ouvertures.

Warnung Aus der Port-Öffnung können unsichtbare Strahlen emittieren, wenn kein Glasfaserkabel angeschlossen ist. Vermeiden Sie es, sich den Strahlungen auszusetzen, und starren Sie nicht in die Öffnungen!

Avvertenza Quando i cavi in fibra non sono inseriti, radiazioni invisibili possono essere emesse attraverso l'apertura della porta. Evitate di esporvi alle radiazioni e non guardate direttamente nelle aperture.

Advarsel Unngå utsettelse for stråling, og stirr ikke inn i åpninger som er åpne, fordi usynlig stråling kan emitteres fra portens åpning når det ikke er tilkoblet en fiberkabel.

Aviso Dada a possibilidade de emissão de radiação invisível através do orifício da via de acesso, quando esta não tiver nenhum cabo de fibra conectado, deverá evitar a exposição à radiação e não deverá olhar fixamente para orifícios que se encontrarem a descoberto.

¡Atención! Debido a que la apertura del puerto puede emitir radiación invisible cuando no existe un cable de fibra conectado, evite mirar directamente a las aperturas para no exponerse a la radiación.

Varning! Osynlig strålning kan avges från en portöppning utan ansluten fiberkabel och du bör därför undvika att bli utsatt för strålning genom att inte stirra in i oskyddade öppningar.

**Related
Documentation**

- [SRX240 Services Gateway Definition of Safety Warning Levels on page 109](#)
- [SRX240 Services Gateway General Safety Guidelines and Warnings on page 111](#)
- [SRX240 Services Gateway Fire Safety Requirements on page 115](#)
- [SRX240 Services Gateway Installation Safety Guidelines and Warnings on page 116](#)
- [SRX240 Services Gateway Maintenance and Operational Safety Guidelines and Warnings on page 125](#)
- [SRX240 Services Gateway Electrical Safety Guidelines and Warnings on page 130](#)

SRX240 Services Gateway Maintenance and Operational Safety Guidelines and Warnings

This topic includes the following sections:

- [Safety Guidelines and Warnings on page 125](#)

Safety Guidelines and Warnings

Battery Handling Warning



WARNING: Replacing the battery incorrectly might result in an explosion. Replace the battery only with the same or equivalent type recommended by the manufacturer. Dispose of used batteries according to the manufacturer's instructions.

Waarschuwing Er is ontploffingsgevaar als de batterij verkeerd vervangen wordt. Vervang de batterij slechts met hetzelfde of een equivalent type dat door de fabrikant aanbevolen is. Gebruikte batterijen dienen overeenkomstig fabrieksvoorschriften weggeworpen te worden.

Varoitus Räjähdyksen vaara, jos akku on vaihdettu väärään akkuun. Käytä vaihtamiseen ainoastaan saman- tai vastaavantyyppistä akkua, joka on valmistajan suosittama. Hävitä käytetyt akut valmistajan ohjeiden mukaan.

Attention Danger d'explosion si la pile n'est pas remplacée correctement. Ne la remplacer que par une pile de type semblable ou équivalent, recommandée par le fabricant. Jeter les piles usagées conformément aux instructions du fabricant.

Warnung Bei Einsetzen einer falschen Batterie besteht Explosionsgefahr. Ersetzen Sie die Batterie nur durch den gleichen oder vom Hersteller empfohlenen Batterietyp. Entsorgen Sie die benutzten Batterien nach den Anweisungen des Herstellers.

Avvertenza Pericolo di esplosione se la batteria non è installata correttamente. Sostituire solo con una di tipo uguale o equivalente, consigliata dal produttore. Eliminare le batterie usate secondo le istruzioni del produttore.

Advarsel Det kan være fare for eksplosjon hvis batteriet skiftes på feil måte. Skift kun med samme eller tilsvarende type som er anbefalt av produsenten. Kasser brukte batterier i henhold til produsentens instruksjoner.

Aviso Existe perigo de explosão se a bateria for substituída incorrectamente. Substitua a bateria por uma bateria igual ou de um tipo equivalente recomendado pelo fabricante. Destrua as baterias usadas conforme as instruções do fabricante.

¡Atención! Existe peligro de explosión si la batería se reemplaza de manera incorrecta. Reemplazar la batería exclusivamente con el mismo tipo o el

equivalente recomendado por el fabricante. Desechar las baterías gastadas según las instrucciones del fabricante.

Varning! Explosionsfara vid felaktigt batteribyte. Ersätt endast batteriet med samma batterityp som rekommenderas av tillverkaren eller motsvarande. Följ tillverkarens anvisningar vid kassering av använda batterier.

Jewelry Removal Warning



WARNING: Before working on equipment that is connected to power lines, remove jewelry, including rings, necklaces, and watches. Metal objects heat up when connected to power and ground and can cause serious burns or weld the metal object to the terminals.

Waarschuwing Alvorens aan apparatuur te werken die met elektrische leidingen is verbonden, sieraden (inclusief ringen, kettingen en horloges) verwijderen. Metalen voorwerpen worden warm wanneer ze met stroom en aarde zijn verbonden, en kunnen ernstige brandwonden veroorzaken of het metalen voorwerp aan de aansluitklemmen lassen.

Varoitus Ennen kuin työskentelet voimavirtajohtoihin kytkettyjen laitteiden parissa, ota pois kaikki korut (sormukset, kaulakorut ja kellot mukaan lukien). Metalliesineet kuumenevat, kun ne ovat yhteydessä sähkövirran ja maan kanssa, ja ne voivat aiheuttaa vakavia palovammoja tai hitsata metalliesineet kiinni liitäntänapoihin.

Attention Avant d'accéder à cet équipement connecté aux lignes électriques, ôter tout bijou (anneaux, colliers et montres compris). Lorsqu'ils sont branchés à l'alimentation et reliés à la terre, les objets métalliques chauffent, ce qui peut provoquer des blessures graves ou souder l'objet métallique aux bornes.

Warnung Vor der Arbeit an Geräten, die an das Netz angeschlossen sind, jeglichen Schmuck (einschließlich Ringe, Ketten und Uhren) abnehmen. Metallgegenstände erhitzen sich, wenn sie an das Netz und die Erde angeschlossen werden, und können schwere Verbrennungen verursachen oder an die Anschlußklemmen angeschweißt werden.

Avvertenza Prima di intervenire su apparecchiature collegate alle linee di alimentazione, togliersi qualsiasi monile (inclusi anelli, collane, braccialetti ed orologi). Gli oggetti metallici si riscaldano quando sono collegati tra punti di alimentazione e massa: possono causare ustioni gravi oppure il metallo può saldarsi ai terminali.

Advarsel Fjern alle smykker (inkludert ringer, halskjeder og klokker) før du skal arbeide på utstyr som er koblet til kraftledninger. Metallgjenstander som er koblet til kraftledninger og jord blir svært varme og kan forårsake alvorlige brannskader eller smelte fast til polene.

Aviso Antes de trabalhar em equipamento que esteja ligado a linhas de corrente, retire todas as jóias que estiver a usar (incluindo anéis, fios e relógios). Os objectos metálicos aquecerão em contacto com a corrente e em contacto com a ligação à terra, podendo causar queimaduras graves ou ficarem soldados aos terminais.

¡Atención! Antes de operar sobre equipos conectados a líneas de alimentación, quitarse las joyas (incluidos anillos, collares y relojes). Los objetos de metal se calientan cuando se conectan a la alimentación y a tierra, lo que puede ocasionar quemaduras graves o que los objetos metálicos queden soldados a los bornes.

Varning! Tag av alla smycken (inklusive ringar, halsband och armbandsur) innan du arbetar på utrustning som är kopplad till kraftledning. Metallobjekt hettas upp när de kopplas ihop med ström och jord och kan förorsaka allvarliga brännskador; metallobjekt kan också sammansvetsas med kontakterna.

Lightning Activity Warning



WARNING: Do not work on the system or connect or disconnect cables during periods of lightning activity.

Waarschuwing Tijdens onweer dat gepaard gaat met bliksem, dient u niet aan het systeem te werken of kabels aan te sluiten of te ontkoppelen.

Varoitus Älä työskentele järjestelmän parissa äläkä yhdistä tai irrota kaapeleita ukkosilmalla.

Attention Ne pas travailler sur le système ni brancher ou débrancher les câbles pendant un orage.

Warnung Arbeiten Sie nicht am System und schließen Sie keine Kabel an bzw. trennen Sie keine ab, wenn es gewittert.

Avvertenza Non lavorare sul sistema o collegare oppure scollegare i cavi durante un temporale con fulmini.

Advarsel Utfør aldri arbeid på systemet, eller koble kabler til eller fra systemet når det tordner eller lyner.

Aviso Não trabalhe no sistema ou ligue e desligue cabos durante períodos de mau tempo (trovoada).

¡Atención! No operar el sistema ni conectar o desconectar cables durante el transcurso de descargas eléctricas en la atmósfera.

Varning! Vid åska skall du aldrig utföra arbete på systemet eller ansluta eller koppla loss kablar.

Operating Temperature Warning



WARNING: To prevent the services gateway from overheating, do not operate it in an area that exceeds the maximum recommended ambient temperature of 104°F (40°C). To prevent airflow restriction, allow at least 6 in. (15.2 cm) of clearance around the ventilation openings.

Waarschuwing Om te voorkomen dat welke services gateway van de Juniper Networks services gateway dan ook oververhit raakt, dient u deze niet te bedienen op een plaats waar de maximale aanbevolen omgevingstemperatuur van 40°C wordt overschreden. Om te voorkomen dat de luchtstroom wordt beperkt, dient er minstens 15,2 cm speling rond de ventilatie-openingen te zijn.

Varoitus Ettei Juniper Networks services gateway-sarjan reititin ylikuumentuisi, sitä ei saa käyttää tilassa, jonka lämpötila ylittää korkeimman suositellun ympäristölämpötilan 40°C. Ettei ilmanvaihto estyisi, tuuletusaukkojen ympärille on jätettävä ainakin 15,2 cm tilaa.

Attention Pour éviter toute surchauffe des routeurs de la gamme Juniper Networks services gateway, ne l'utilisez pas dans une zone où la température ambiante est supérieure à 40°C. Pour permettre un flot d'air constant, dégagez un espace d'au moins 15,2 cm autour des ouvertures de ventilations.

Warnung Um einen services gateway der services gateway vor Überhitzung zu schützen, darf dieser nicht in einer Gegend betrieben werden, in der die Umgebungstemperatur das empfohlene Maximum von 40°C überschreitet. Um Lüftungsverschluß zu verhindern, achten Sie darauf, daß mindestens 15,2 cm lichter Raum um die Lüftungsöffnungen herum frei bleibt.

Avvertenza Per evitare il surriscaldamento dei services gateway, non adoperateli in un locale che ecceda la temperatura ambientale massima di 40°C. Per evitare che la circolazione dell'aria sia impedita, lasciate uno spazio di almeno 15.2 cm di fronte alle aperture delle ventole.

Advarsel Unngå overoppheting av eventuelle rutere i Juniper Networks services gateway Disse skal ikke brukes på steder der den anbefalte maksimale omgivelsestemperaturen overstiger 40°C (104°F). Sørg for at klaringen rundt lufteåpningene er minst 15,2 cm (6 tommer) for å forhindre nedsatt luftsirkulasjon.

Aviso Para evitar o sobreaquecimento do encaminhador Juniper Networks services gateway, não utilize este equipamento numa área que exceda a temperatura máxima recomendada de 40°C. Para evitar a restrição à circulação de ar, deixe pelo menos um espaço de 15,2 cm à volta das aberturas de ventilação.

¡Atención! Para impedir que un encaminhador de la serie Juniper Networks services gateway se recaliente, no lo haga funcionar en un área en la que se

supere la temperatura ambiente máxima recomendada de 40°C. Para impedir la restricción de la entrada de aire, deje un espacio mínimo de 15,2 cm alrededor de las aperturas para ventilación.

Warning! Förhindra att en Juniper Networks services gateway överhettas genom att inte använda den i ett område där den maximalt rekommenderade omgivningstemperaturen på 40°C överskrids. Förhindra att luftcirkulationen inskränks genom att se till att det finns fritt utrymme på minst 15,2 cm omkring ventilationsöppningarna.

Product Disposal Warning



WARNING: Disposal of this product must be handled according to all national laws and regulations.

Waarschuwing Dit produkt dient volgens alle landelijke wetten en voorschriften te worden afgedankt.

Varoitus Tämän tuotteen lopullisesta hävittämisestä tulee huolehtia kaikkia valtakunnallisia lakeja ja säännöksiä noudattaen.

Attention La mise au rebut définitive de ce produit doit être effectuée conformément à toutes les lois et réglementations en vigueur.

Warnung Dieses Produkt muß den geltenden Gesetzen und Vorschriften entsprechend entsorgt werden.

Avvertenza L'eliminazione finale di questo prodotto deve essere eseguita osservando le normative italiane vigenti in materia

Advarsel Endelig disponering av dette produktet må skje i henhold til nasjonale lover og forskrifter.

Aviso A descartagem final deste produto deverá ser efectuada de acordo com os regulamentos e a legislação nacional.

¡Atención! El desecho final de este producto debe realizarse según todas las leyes y regulaciones nacionales

Warning! Slutlig kassering av denna produkt bör skötas i enlighet med landets alla lagar och föreskrifter.

Related Documentation

- [SRX240 Services Gateway Definition of Safety Warning Levels on page 109](#)
- [SRX240 Services Gateway General Safety Guidelines and Warnings on page 111](#)
- [SRX240 Services Gateway Fire Safety Requirements on page 115](#)
- [SRX240 Services Gateway Installation Safety Guidelines and Warnings on page 116](#)

- [SRX240 Services Gateway Laser and LED Safety Guidelines and Warnings on page 121](#)
- [SRX240 Services Gateway Electrical Safety Guidelines and Warnings on page 130](#)

[SRX240 Services Gateway Electrical Safety Guidelines and Warnings](#)

When working on equipment powered by electricity, follow the safety guidelines.

This topic includes the following sections:

- [Electrical Safety Guidelines and Warnings on page 130](#)

Electrical Safety Guidelines and Warnings

[In Case of Electrical Accident](#)

If an electrical accident results in an injury, take the following actions in this order:

1. Use caution. Be aware of potentially hazardous conditions that could cause further injury.
2. Disconnect power from the services gateway.
3. If possible, send another person to get medical aid. Otherwise, assess the condition of the victim, then call for help.

[General Electrical Safety Guidelines and Warnings](#)



WARNING: Certain ports on the services gateway are designed for use as intrabuilding (within-the-building) interfaces only (Type 2 or Type 4 ports as described in GR-1089-CORE, Issue 4) and require isolation from the exposed outside plant (OSP) cabling. To comply with NEBS requirements and protect against lightning surges and commercial power disturbances, the intrabuilding ports must not be metallically connected to interfaces that connect to the OSP or its wiring. The intrabuilding ports on the switch are suitable for connection to intrabuilding or unexposed wiring or cabling only. The addition of primary protectors is not sufficient protection for connecting these interfaces metallically to OSP wiring.

- Install the services gateway in compliance with the following local, national, or international electrical codes:
 - United States—National Fire Protection Association (NFPA 70), United States National Electrical Code
 - Canada—Canadian Electrical Code, Part 1, CSA C22.1

- Other countries—International Electromechanical Commission (IEC) 60364, Part 1 through Part 7
- Evaluated to the TN power system
- Locate the emergency power-off switch for the room in which you are working so that if an electrical accident occurs, you can quickly turn off the power.
- Do not work alone if potentially hazardous conditions exist anywhere in your workspace.
- Never assume that power is disconnected from a circuit. Always check the circuit before starting to work.
- Carefully look for possible hazards in your work area, such as moist floors, ungrounded power extension cords, and missing safety grounds.
- Operate the services gateway within marked electrical ratings and product usage instructions.
- For the services gateway and peripheral equipment to function safely and correctly, use the cables and connectors specified for the attached peripheral equipment, and make certain they are in good condition.

Copper Conductors Warning



WARNING: Use copper conductors only.

Waarschuwing Gebruik alleen koperen geleiders.

Varoitus Käytä vain kuparijohtimia.

Attention Utilisez uniquement des conducteurs en cuivre.

Warnung Verwenden Sie ausschließlich Kupferleiter.

Avvertenza Usate unicamente dei conduttori di rame.

Advarsel Bruk bare kobberledninger.

Aviso Utilize apenas fios condutores de cobre.

¡Atención! Emplee sólo conductores de cobre.

Varning! Använd endast ledare av koppar.

Related Documentation

- [SRX240 Services Gateway Definition of Safety Warning Levels on page 109](#)
- [SRX240 Services Gateway General Safety Guidelines and Warnings on page 111](#)
- [SRX240 Services Gateway Fire Safety Requirements on page 115](#)
- [SRX240 Services Gateway Installation Safety Guidelines and Warnings on page 116](#)
- [SRX240 Services Gateway Laser and LED Safety Guidelines and Warnings on page 121](#)

- [SRX240 Services Gateway Maintenance and Operational Safety Guidelines and Warnings on page 125](#)

DC Power Electrical Safety Guidelines and Warnings

This topic includes the following sections:

- [DC Power Electrical Safety Guidelines on page 132](#)
- [DC Power Disconnection Warning on page 133](#)
- [DC Power Grounding Requirements and Warning on page 134](#)
- [DC Power Wiring Sequence Warning on page 135](#)
- [DC Power Wiring Terminations Warning on page 136](#)

DC Power Electrical Safety Guidelines

The following electrical safety guidelines apply to a DC-powered services gateway:

- A DC-powered services gateway is equipped with a DC terminal block that is rated for the power requirements of a maximally configured services gateway. To supply sufficient power, terminate the DC input wiring on a facility DC source capable of supplying at least 5 A @ –48 VDC for the system. We recommend that the 48 VDC facility DC source be equipped with a circuit breaker rated at 10 A (–48 VDC) minimum, or as required by local code. Incorporate an easily accessible disconnect device into the facility wiring. In the United States and Canada, the –48 VDC facility must be equipped with a circuit breaker rated a minimum of 125% of the power provisioned for the input in accordance with the National Electrical Code in the US and the Canadian Electrical Code in Canada. Be sure to connect the ground wire or conduit to a solid office (earth) ground. A closed loop ring is recommended for terminating the ground conductor at the ground stud.
- Run two wires from the circuit breaker box to a source of 48 VDC. Use appropriate gauge wire to handle up to 10 A.
- A DC-powered services gateway that is equipped with a DC terminal block is intended only for installation in a restricted access location. In the United States, a restricted access area is one in accordance with Articles 110-16, 110-17, and 110-18 of the National Electrical Code ANSI/NFPA 70.



NOTE: Primary overcurrent protection is provided by the building circuit breaker. This breaker must protect against excess currents, short circuits, and earth faults in accordance with NEC ANSI/NFPA70.

- Ensure that the polarity of the DC input wiring is correct. Under certain conditions, connections with reversed polarity might trip the primary circuit breaker or damage the equipment.
- For personal safety, connect the green and yellow wire to safety (earth) ground at both the services gateway and the supply side of the DC wiring.

- The marked input voltage of –48 VDC for a DC-powered services gateway is the nominal voltage associated with the battery circuit, and any higher voltages are only to be associated with float voltages for the charging function.
- Because the services gateway is a positive ground system, you must connect the positive lead to the terminal labeled **RETURN**, the negative lead to the terminal labeled **–48V**, and the earth ground to the chassis grounding points.

DC Power Disconnection Warning



WARNING: Before performing any of the following procedures, ensure that power is removed from the DC circuit. To ensure that all power is off, locate the circuit breaker on the panel board that services the DC circuit, switch the circuit breaker to the OFF position, and tape the switch handle of the circuit breaker in the OFF position.

Waarschuwing Voordat u een van de onderstaande procedures uitvoert, dient u te controleren of de stroom naar het gelijkstroom circuit uitgeschakeld is. Om u ervan te verzekeren dat alle stroom UIT is geschakeld, kiest u op het schakelbord de stroomverbreker die het gelijkstroom circuit bedient, draait de stroomverbreker naar de UIT positie en plakt de schakelaarhendel van de stroomverbreker met plakband in de UIT positie vast.

Varoitus Varmista, että tasavirtapiirissä ei ole virtaa ennen seuraavien toimenpiteiden suorittamista. Varmistaaksesi, että virta on KATKAISTU täysin, paikanna tasavirrasta huolehtivassa kojetaulussa sijaitseva suojakytkin, käännä suojakytkin KATKAISTU-asentoon ja teippaa suojakytkimen varsi niin, että se pysyy KATKAISTU-asennossa.

Attention Avant de pratiquer l'une quelconque des procédures ci-dessous, vérifiez que le circuit en courant continu n'est plus sous tension. Pour en être sûr, localiser le disjoncteur situé sur le panneau de service du circuit en courant continu, placer le disjoncteur en position fermée (OFF) et, à l'aide d'un ruban adhésif, bloquer la poignée du disjoncteur en position OFF.

Warnung Vor Ausführung der folgenden Vorgänge ist sicherzustellen, daß die Gleichstromschaltung keinen Strom erhält. Um sicherzustellen, daß sämtlicher Strom abgestellt ist, machen Sie auf der Schalttafel den Unterbrecher für die Gleichstromschaltung ausfindig, stellen Sie den Unterbrecher auf AUS, und kleben Sie den Schaltergriff des Unterbrechers mit Klebeband in der AUS-Stellung fest.

Avvertenza Prima di svolgere una qualsiasi delle procedure seguenti, verificare che il circuito CC non sia alimentato. Per verificare che tutta l'alimentazione sia scollegata (OFF), individuare l'interruttore automatico sul quadro strumenti che alimenta il circuito CC, mettere l'interruttore in posizione OFF e fissarlo con nastro adesivo in tale posizione.

Advarsel Før noen av disse prosedyrene utføres, kontroller at strømmen er frakoblet likestrømkretsen. Sørg for at all strøm er slått AV. Dette gjøres ved

å lokalisere strømbryteren på brytertavlen som betjener likestrømkretsen, slå strømbryteren AV og teipe bryterhåndtaket på strømbryteren i AV-stilling.

Aviso Antes de executar um dos seguintes procedimentos, certifique-se que desligou a fonte de alimentação de energia do circuito de corrente contínua. Para se assegurar que toda a corrente foi DESLIGADA, localize o disjuntor no painel que serve o circuito de corrente contínua e coloque-o na posição OFF (Desligado), segurando nessa posição a manivela do interruptor do disjuntor com fita isoladora.

¡Atención! Antes de proceder con los siguientes pasos, comprobar que la alimentación del circuito de corriente continua (CC) esté cortada (OFF). Para asegurarse de que toda la alimentación esté cortada (OFF), localizar el interruptor automático en el panel que alimenta al circuito de corriente continua, cambiar el interruptor automático a la posición de Apagado (OFF), y sujetar con cinta la palanca del interruptor automático en posición de Apagado (OFF).

Warning! Innan du utför någon av följande procedurer måste du kontrollera att strömförsörjningen till likströmskretsen är bruten. Kontrollera att all strömförsörjning är BRUTEN genom att slå AV det överspänningsskydd som skyddar likströmskretsen och tejpa fast överspänningsskyddets omkopplare i FRÅN-läget.

DC Power Grounding Requirements and Warning

An insulated grounding conductor that is identical in size to the grounded and ungrounded branch circuit supply conductors, but is identifiable by green and yellow stripes, is installed as part of the branch circuit that supplies the unit. The grounding conductor is a separately derived system at the supply transformer or motor generator set.



WARNING: When installing the services gateway, the ground connection must always be made first and disconnected last.

Waarschuwing Bij de installatie van het toestel moet de aardverbinding altijd het eerste worden gemaakt en het laatste worden losgemaakt.

Varoitus Laitetta asennettaessa on maahan yhdistäminen aina tehtävä ensiksi ja maadoituksen irti kytkeminen viimeiseksi.

Attention Lors de l'installation de l'appareil, la mise à la terre doit toujours être connectée en premier et déconnectée en dernier.

Warnung Der Erdanschluß muß bei der Installation der Einheit immer zuerst hergestellt und zuletzt abgetrennt werden.

Avvertenza In fase di installazione dell'unità, eseguire sempre per primo il collegamento a massa e disconnetterlo per ultimo.

Advarsel Når enheten installeres, må jordledningen alltid tilkobles først og frakobles sist.

Aviso Ao instalar a unidade, a ligação à terra deverá ser sempre a primeira a ser ligada, e a última a ser desligada.

¡Atención! Al instalar el equipo, conectar la tierra la primera y desconectarla la última.

Varning! Vid installation av enheten måste jordledningen alltid anslutas först och kopplas bort sist.

DC Power Wiring Sequence Warning



WARNING: Wire the DC power supply using the appropriate lugs. When connecting power, the proper wiring sequence is ground to ground, +RTN to +RTN, then –48 V to –48 V. When disconnecting power, the proper wiring sequence is –48 V to –48 V, +RTN to +RTN, then ground to ground. Note that the ground wire must always be connected first and disconnected last.

Waarschuwing De juiste bedradingsvolgorde verbonden is aarde naar aarde, +RTN naar +RTN, en –48 V naar –48 V. De juiste bedradingsvolgorde losgemaakt is en –48 V naar –48 V, +RTN naar +RTN, aarde naar aarde.

Varoitus Oikea yhdistettävä kytkentäjäjestys on maajohto maajohtoon, +RTN varten +RTN, –48 V varten –48 V. Oikea irrotettava kytkentäjäjestys on –48 V varten –48 V, +RTN varten +RTN, maajohto maajohtoon.

Attention Câblez l'alimentation CC En utilisant les crochets appropriés à l'extrémité de câblage. En reliant la puissance, l'ordre approprié de câblage est rectifié pour rectifier, +RTN à +RTN, puis –48 V à –48 V. En débranchant la puissance, l'ordre approprié de câblage est –48 V à –48 V, +RTN à +RTN, a alors rectifié pour rectifier. Notez que le fil de masse devrait toujours être relié d'abord et débranché pour la dernière fois. Notez que le fil de masse devrait toujours être relié d'abord et débranché pour la dernière fois.

Warnung Die Stromzufuhr ist nur mit geeigneten Ringösen an das DC Netzteil anzuschliessen. Die richtige Anschlusssequenz ist: Erdanschluss zu Erdanschluss, +RTN zu +RTN und dann –48V zu –48V. Die richtige Sequenz zum Abtrennen der Stromversorgung ist –48V zu –48V, +RTN zu +RTN und dann Erdanschluss zu Erdanschluss. Es ist zu beachten dass der Erdanschluss immer zuerst angeschlossen und als letztes abgetrennt wird.

Avvertenza Mostra la morsettiera dell'alimentatore CC. Cablare l'alimentatore CC usando i connettori adatti all'estremità del cablaggio, come illustrato. La corretta sequenza di cablaggio è da massa a massa, da positivo a positivo

(da linea ad L) e da negativo a negativo (da neutro a N). Tenere presente che il filo di massa deve sempre venire collegato per primo e scollegato per ultimo.

Advarsel Riktig tilkoples tilkoplingssekvens er jord til jord, +RTN til +RTN, –48 V til –48 V. Riktig frakoples tilkoplingssekvens er –48 V til –48 V, +RTN til +RTN, jord til jord.

Aviso Ate con alambre la fuente de potencia cc Usando los terminales apropiados en el extremo del cableado. Al conectar potencia, la secuencia apropiada del cableado se muele para moler, +RTN a +RTN, entonces –48 V a –48 V. Al desconectar potencia, la secuencia apropiada del cableado es –48 V a –48 V, +RTN a +RTN, entonces molió para moler. Observe que el alambre de tierra se debe conectar siempre primero y desconectar por último. Observe que el alambre de tierra se debe conectar siempre primero y desconectar por último.

Atenção! Wire a fonte de alimentação de DC Usando os talões apropriados na extremidade da fiação. Ao conectar a potência, a seqüência apropriada da fiação é moída para moer, +RTN a +RTN, então –48 V a –48 V. Ao desconectar a potência, a seqüência apropriada da fiação é –48 V a –48 V, +RTN a +RTN, moeu então para moer. Anote que o fio à terra deve sempre ser conectado primeiramente e desconectado por último. Anote que o fio à terra deve sempre ser conectado primeiramente e desconectado por último.

Varning! Korrekt kopplingssekvens ar jord till jord, +RTN till +RTN, –48 V till –48 V. Korrekt kopplas kopplingssekvens ar –48 V till –48 V, +RTN till +RTN, jord till jord.

DC Power Wiring Terminations Warning



WARNING: When stranded wiring is required, use approved wiring terminations, such as closed-loop or spade-type with upturned lugs. These terminations should be the appropriate size for the wires and should clamp both the insulation and the conductor.

Waarschuwing Wanneer geslagen bedrading vereist is, dient u bedrading te gebruiken die voorzien is van goedgekeurde aansluitingspunten, zoals het gesloten-lus type of het grijperschop type waarbij de aansluitpunten omhoog wijzen. Deze aansluitpunten dienen de juiste maat voor de draden te hebben en dienen zowel de isolatie als de geleider vast te klemmen.

Varoitus Jos säikeellinen johdin on tarpeen, käytä hyväksyttyä johdinliitäntää, esimerkiksi suljettua silmukkaa tai kourumaista liitäntää, jossa on ylöspäin käännetyt kiinnityskorvat. Tällaisten liitäntöjen tulee olla kooltaan johtimiin sopivia ja niiden tulee puristaa yhteen sekä eristeen että johdinosan.

Attention Quand des fils torsadés sont nécessaires, utiliser des douilles terminales homologuées telles que celles à circuit fermé ou du type à plage

ouverte avec cosses rebroussées. Ces douilles terminales doivent être de la taille qui convient aux fils et doivent être refermées sur la gaine isolante et sur le conducteur.

Warnung Wenn Litzenverdrahtung erforderlich ist, sind zugelassene Verdrahtungsanschlüsse, z.B. Ringoesen oder gabelförmige Kabelschuhe mit nach oben gerichteten Enden zu verwenden. Diese Abschlüsse sollten die angemessene Größe für die Drähte haben und sowohl die Isolierung als auch den Leiter festklemmen.

Avvertenza Quando occorre usare trecce, usare connettori omologati, come quelli a occhiello o a forcella con linguette rivolte verso l'alto. I connettori devono avere la misura adatta per il cablaggio e devono serrare sia l'isolante che il conduttore.

Advarsel Hvis det er nødvendig med flertrådede ledninger, brukes godkjente ledningsavslutninger, som for eksempel lukket sløyfe eller spadetype med oppoverbøyde kabelsko. Disse avslutningene skal ha riktig størrelse i forhold til ledningene, og skal klemme sammen både isolasjonen og ledaren.

Aviso Quando forem requeridas montagens de instalação eléctrica de cabo torcido, use terminações de cabo aprovadas, tais como, terminações de cabo em circuito fechado e planas com terminais de orelha voltados para cima. Estas terminações de cabo deverão ser do tamanho apropriado para os respectivos cabos, e deverão prender simultaneamente o isolamento e o fio condutor.

¡Atención! Cuando se necesite hilo trenzado, utilizar terminales para cables homologados, tales como las de tipo "bucle cerrado" o "espada", con las lengüetas de conexión vueltas hacia arriba. Estos terminales deberán ser del tamaño apropiado para los cables que se utilicen, y tendrán que sujetar tanto el aislante como el conductor.

Varning! När flertrådiga ledningar krävs måste godkända ledningskontakter användas, t.ex. kabelsko av sluten eller öppen typ med uppåtvänd tapp. Storleken på dessa kontakter måste vara avpassad till ledningarna och måste kunna hålla både isoleringen och ledaren fastklämda.

**Related
Documentation**

- [SRX240 Services Gateway Definition of Safety Warning Levels on page 109](#)
- [SRX240 Services Gateway General Safety Guidelines and Warnings on page 111](#)
- [SRX240 Services Gateway Fire Safety Requirements on page 115](#)
- [SRX240 Services Gateway Installation Safety Guidelines and Warnings on page 116](#)
- [SRX240 Services Gateway Laser and LED Safety Guidelines and Warnings on page 121](#)
- [SRX240 Services Gateway Maintenance and Operational Safety Guidelines and Warnings on page 125](#)

SRX240 Services Gateway Agency Approvals

The services gateway complies with the following standards:

- Safety
 - CAN/CSA-C22.2 No. 60950-1 (2007) Information Technology Equipment
 - UL 60950-1 (2nd Edition) Information Technology Equipment
 - EN 60950-1 (2005) Information Technology Equipment
 - IEC 60950-1 (2005) Information Technology Equipment
 - EN 60825-1 +A1+A2 (1994) Safety of Laser Products - Part 1: Equipment Classification
- EMC
 - EN 300 386 V1.3.3 (2005) Telecom Network Equipment - EMC requirements
- EMI
 - FCC Part 15 Class A (2007) USA Radiated Emissions
 - EN 55022 Class A (2006) European Radiated Emissions
 - VCCI Class A (2007) Japanese Radiated Emissions
- Immunity
 - EN 55024 +A1+A2 (1998) Information Technology Equipment Immunity Characteristics
 - EN-61000-3-2 (2006) Power Line Harmonics
 - EN-61000-3-3 +A1 +A2 +A3 (1995) Power Line Voltage Fluctuations
 - EN-61000-4-2 +A1 +A2 (1995) Electrostatic Discharge
 - EN-61000-4-3 +A1+A2 (2002) Radiated Immunity
 - EN-61000-4-4 (2004) Electrical Fast Transients
 - EN-61000-4-5 (2006) Surge
 - EN-61000-4-6 (2007) Immunity to Conducted Disturbances
 - EN-61000-4-11 (2004) Voltage Dips and Sags

**Related
Documentation**

- [SRX240 Services Gateway Compliance Statements for EMC Requirements on page 139](#)
- [SRX240 Services Gateway Compliance Statements for Environmental Requirements on page 140](#)
- [SRX240 Services Gateway Compliance Statements for Acoustic Noise on page 141](#)

SRX240 Services Gateway Compliance Statements for EMC Requirements

This topic includes the following sections:

- [Canada on page 139](#)
- [European Community on page 139](#)
- [Israel on page 139](#)
- [Japan on page 139](#)
- [United States on page 140](#)

Canada

This Class A digital apparatus complies with Canadian ICES-003.

Cet appareil numérique de la classe A est conforme à la norme NMB-003 du Canada.

European Community

This is a Class A product. In a domestic environment this product may cause radio interference in which case the user may be required to take adequate measures.

Israel

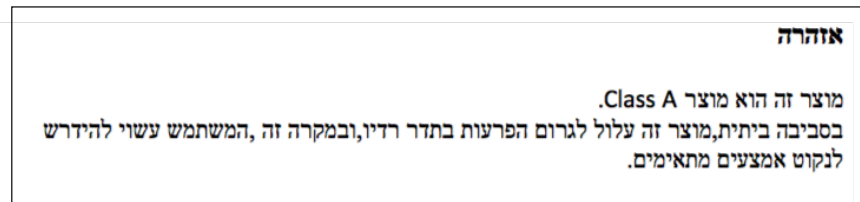

The preceding translates as follows:

This product is Class A. In residential environments, the product may cause radio interference, and in such a situation, the user may be required to take adequate measures.

Japan

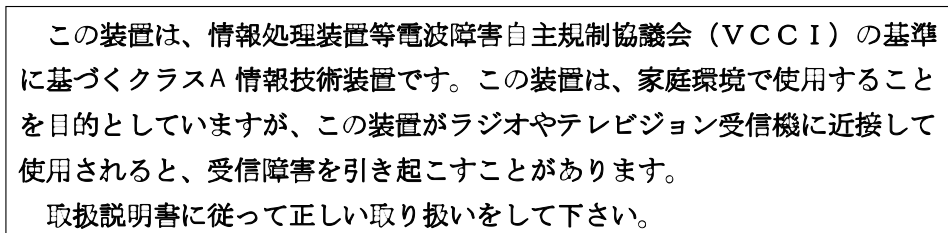

The preceding translates as follows:

This is a Class A product based on the standard of the Voluntary Control Council for Interference by Information Technology Equipment (VCCI). If this product is used near

a radio or television receiver in a domestic environment, it may cause radio interference. Install and use the equipment according to the instruction manual.

United States

The services gateway has been tested and found to comply with the limits for a Class A digital device of the FCC Rules. These limits are designed to provide reasonable protection against harmful interference when the equipment is operated in a commercial environment. This equipment generates, uses, and can radiate radio frequency energy and, if not installed and used in accordance with the instruction manual, may cause harmful interference to radio communications. Operation of this equipment in a residential area is likely to cause harmful interference in which case the user will be required to correct the interference at his own expense.

Related Documentation

- [SRX240 Services Gateway Compliance Statements for Environmental Requirements on page 140](#)
- [SRX240 Services Gateway Agency Approvals on page 138](#)
- [SRX240 Services Gateway Compliance Statements for Acoustic Noise on page 141](#)

SRX240 Services Gateway (DC Power Supply Model) Compliance Statements for Network Equipment Building System (NEBS)

This product complies with the following NEBS standards:

- The equipment is suitable for installation as part of the Common Bonding Network (CBN).
- The equipment is suitable for installation in locations where the National Electrical Code (NEC) applies.
- The battery return connection is to be treated as an Isolated DC return (DC-I), as defined in GR-1089-CORE
- The minimum steady-state operating voltage is -40.5 V (after turn on at minimum of 44 VDC).

Related Documentation

- [SRX240 Services Gateway Compliance Statements for Environmental Requirements on page 140](#)
- [SRX240 Services Gateway Agency Approvals on page 138](#)
- [SRX240 Services Gateway Compliance Statements for Acoustic Noise on page 141](#)

SRX240 Services Gateway Compliance Statements for Environmental Requirements

This topic includes the compliance statement for the following environmental requirement:

Lithium Battery

Batteries in this product are not based on mercury, lead, or cadmium substances. The batteries used in this product are in compliance with EU Directives 91/157/EEC, 93/86/EEC, and 98/101/EEC. The product documentation includes instructional information about the proper method of reclamation and recycling.

- Related Documentation**
- [SRX240 Services Gateway Compliance Statements for EMC Requirements on page 139](#)
 - [SRX240 Services Gateway Compliance Statements for Acoustic Noise on page 141](#)
 - [SRX240 Services Gateway Agency Approvals on page 138](#)

SRX240 Services Gateway Compliance Statements for Acoustic Noise

Maschinenlärminformations-Verordnung - 3. GPSGV, der höchste Schalldruckpegel beträgt 70 dB(A) oder weniger gemäss EN ISO 7779

Translation:

The maximum emitted sound pressure level is 70 dB(A) or less per EN ISO 7779.

- Related Documentation**
- [SRX240 Services Gateway Compliance Statements for EMC Requirements on page 139](#)
 - [SRX240 Services Gateway Compliance Statements for Environmental Requirements on page 140](#)
 - [SRX240 Services Gateway Agency Approvals on page 138](#)

APPENDIX B

SRX240 Services Gateway Power Guidelines, Requirements, and Specifications

This appendix includes the following topics:

- [SRX240 Services Gateway Site Electrical Wiring Guidelines on page 143](#)
- [SRX240 Services Gateway AC Power Specifications and Requirements on page 145](#)
- [SRX240 Services Gateway DC Power Specifications and Requirements on page 146](#)
- [SRX240 Services Gateway Grounding Specifications on page 147](#)

SRX240 Services Gateway Site Electrical Wiring Guidelines

[Table 36 on page 144](#) describes the factors you must consider while planning the electrical wiring for the services gateway at your site.



.....
CAUTION: It is particularly important to provide a properly grounded and shielded environment and to use electrical surge-suppression devices.
.....



.....
CAUTION: For devices with AC power supplies, an external surge protective device (SPD) must be used at the AC power source.
.....

Table 36: Site Electrical Wiring Guidelines for the Services Gateway

Site Wiring Factor	Guideline
Signaling Limitations	<p>To ensure that signaling functions optimally:</p> <ul style="list-style-type: none"> Install wires correctly. Improperly installed wires can emit radio interference. Do not exceed the recommended distances or pass wires between buildings. The potential for damage from lightning strikes increases if wires exceed recommended distances or if wires pass between buildings. Shield all conductors. The electromagnetic pulse (EMP) caused by lightning can damage unshielded conductors and destroy electronic devices.
Radio Frequency Interference (RFI)	<p>To reduce or eliminate the emission of RFI from your site wiring:</p> <ul style="list-style-type: none"> Use twisted-pair cable with a good distribution of grounding conductors. Use a high-quality twisted-pair cable with one ground conductor for each data signal when applicable, if you must exceed the recommended distances.
Electromagnetic Compatibility (EMC)	<p>Provide a properly grounded and shielded environment and use electrical surge-suppression devices.</p> <p>Strong sources of electromagnetic interference (EMI) can cause the following damage:</p> <ul style="list-style-type: none"> Destroy the signal drivers and receivers in the device Conduct power surges over the lines into the equipment, resulting in an electrical hazard <p>NOTE: If your site is susceptible to problems with EMC, particularly from lightning or radio transmitters, you may want to seek expert advice.</p>



CAUTION: To comply with intrabuilding lightning/surge requirements, the intrabuilding wiring must be shielded. The shielding for the wiring must be grounded at both ends.

Related Documentation

- [SRX240 Services Gateway AC Power Specifications and Requirements on page 145](#)
- [SRX240 Services Gateway Grounding Specifications on page 147](#)
- [SRX240 Services Gateway Power Supply on page 20](#)

SRX240 Services Gateway AC Power Specifications and Requirements

This topic includes the following sections:

- [AC Power Requirement Specifications on page 145](#)
- [AC Power Cord Specifications on page 145](#)

AC Power Requirement Specifications

The AC power system electrical specifications for the SRX240 Services Gateway are listed in [Table 37 on page 145](#).

Table 37: AC Power Supply Specifications for the SRX240 Services Gateway

Power Requirement	Specification
AC input voltage	100 to 240 VAC
AC input line frequency	50 to 60 Hz
AC system current rating	2.5 A 4.5 A (for PoE models)

AC Power Cord Specifications

[Table 38 on page 145](#) depicts the plugs on the AC power cords provided for each country or region.

Table 38: AC Power Cord Specifications

Country	Model Number
Australia	CBL-JX-PWR-AU
China	CBL-JX-PWR-CH
Europe (except Denmark, Italy, Switzerland, and United Kingdom)	CBL-JX-PWR-EU
Italy	CBL-JX-PWR-IT
Japan	CBL-JX-PWR-JP
North America	CBL-JX-PWR-US
United Kingdom	CBL-JX-PWR-UK



WARNING: The AC power cord for the services gateway is intended for use with the services gateway only and not for any other use.

Related Documentation

- [SRX240 Services Gateway Site Electrical Wiring Guidelines on page 143](#)
- [SRX240 Services Gateway Grounding Specifications on page 147](#)
- [SRX240 Services Gateway Power Supply on page 20](#)
- [SRX240 Services Gateway DC Power Specifications and Requirements on page 146](#)

SRX240 Services Gateway DC Power Specifications and Requirements

This topic includes the following sections:

- [DC Power System Electrical Specifications on page 146](#)
- [DC Power Cable Specifications on page 146](#)

DC Power System Electrical Specifications

Table 39 on page 146 lists the DC power system electrical specifications.

Table 39: DC Power Supply Specifications for the SRX240 Services Gateway

Power Requirement	Specification
DC input voltage	Operating range: -40.5 to -72 VDC
DC system current rating	5A @ -48 VDC

DC Power Cable Specifications

Table 40 on page 146 summarizes the specifications for the power cables, which you must supply.

Table 40: DC Power Supply Cable Specifications for the SRX240 Services Gateway

Cable Type	Specification
Power	Four 12-14 AWG (3.31 to 2.08 mm ²), minimum 60°C wire, or as permitted by the local code.

Related Documentation

- [SRX240 Services Gateway Site Electrical Wiring Guidelines on page 143](#)
- [SRX240 Services Gateway Grounding Specifications on page 147](#)
- [SRX240 Services Gateway Power Supply on page 20](#)

- [Connecting the SRX240 Services Gateway DC Power Supply Model to a DC Power Source on page 50](#)

SRX240 Services Gateway Grounding Specifications

To meet safety and electromagnetic interference (EMI) requirements and to ensure proper operation, the services gateway must be adequately grounded before power is connected. A grounding lug available on the rear of the services gateway chassis is used to connect the device to earth ground.



WARNING: Before device installation begins, a licensed electrician must attach a cable lug to the grounding and power cables that you supply. A cable with an incorrectly attached lug can damage the device (for example, by causing a short circuit).

To ground the device before connecting power, you connect the grounding cable to earth ground and then attach the lug on the cable to the chassis grounding point with the screw.

[Table 41 on page 147](#) lists the specifications of the grounding cable used with the device.

Table 41: Grounding Cable Specifications for the Services Gateway

Grounding Requirement	Specification
Grounding cable	14 AWG single-strand wire cable
Amperage of grounding cable	Up to 25 A
Grounding lug	Ring-type, vinyl-insulated TV14-6R lug or equivalent

Related Documentation

- [SRX240 Services Gateway Site Electrical Wiring Guidelines on page 143](#)
- [Grounding the SRX240 Services Gateway on page 55](#)
- [SRX240 Services Gateway AC Power Specifications and Requirements on page 145](#)
- [SRX240 Services Gateway Power Supply on page 20](#)

APPENDIX C

SRX240 Services Gateway Interface Cable Specifications and Connector Pinouts

This appendix includes the following topics:

- [Interface Cable and Wire Specifications for the SRX240 Services Gateway on page 149](#)
- [RJ-45 Connector Pinouts for the SRX240 Services Gateway Ethernet Port on page 149](#)
- [RJ-45 Connector Pinouts for the SRX240 Services Gateway Console Port on page 151](#)

Interface Cable and Wire Specifications for the SRX240 Services Gateway

Table 42 on page 149 lists the specifications for the cables that connect to ports.

Table 42: Cable and Wire Specifications for Ports

Port	Cable Specification	Cable/Wire Required	Maximum Length	Device Receptacle
Console port	RS-232 (EIA-232) serial cable	One 6-ft (1.83-m) length with DB-9/RJ-45 connectors	6 ft (1.83 m)	RJ-45
Ethernet port	CAT-5e (Category 5) cable or equivalent suitable for 100BASE-T operation	One 15-ft (4.57-m) length with RJ-45/RJ-45 connectors	328 ft (100 m)	RJ-45

Related Documentation

- [RJ-45 Connector Pinouts for the SRX240 Services Gateway Ethernet Port on page 149](#)
- [RJ-45 Connector Pinouts for the SRX240 Services Gateway Console Port on page 151](#)

RJ-45 Connector Pinouts for the SRX240 Services Gateway Ethernet Port

Figure 24 on page 150 shows the RJ-45 cable connector pinouts for Ethernet ports.

Figure 24: Ethernet Cable Connector (RJ-45)

Table 43 on page 150 describes the RJ-45 connector pinouts for the Ethernet port for 10/100 Mbps.

Table 43: RJ-45 Connector Pinouts for the Services Gateway Ethernet Port (10/100 Mbps)

Pin	Signal
1	TX+
2	TX-
3	RX+
4	Termination network
5	Termination network
6	RX-
7	Termination network
8	Termination network

Table 44 on page 150 describes the RJ-45 connector pinouts for the Ethernet port for 1 Gbps (1000 Mbps).

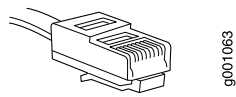
Table 44: RJ-45 Connector Pinouts for the Services Gateway Ethernet Port (1 Gbps)

Pin	Signal
1	BI_DA+
2	BI_DA-
3	BI_DB+
4	BI_DC+
5	BI_DC-
6	BI_DB-
7	BI_DD+

Table 44: RJ-45 Connector Pinouts for the Services Gateway Ethernet Port (1 Gbps) (continued)

Pin	Signal
8	BL_DD-

Related Documentation

- [Interface Cable and Wire Specifications for the SRX240 Services Gateway on page 149](#)
- [RJ-45 Connector Pinouts for the SRX240 Services Gateway Console Port on page 151](#)

RJ-45 Connector Pinouts for the SRX240 Services Gateway Console Port

Figure 25 on page 151 shows the RJ-45 connector pinouts for the console port.

Figure 25: Console Cable Connector

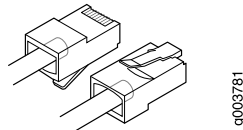

Table 45 on page 151 describes the RJ-45 connector pinouts for the console port.

Table 45: RJ-45 Connector Pinouts for the Services Gateway Console Port

Pin	Signal	Description
1	RTS	Request to Send
2	DTR	Data Terminal Ready
3	TXD	Transmit Data
4	Ground	Signal Ground
5	Ground	Signal Ground
6	RXD	Receive Data
7	DSR/DCD	Data Set Ready
8	CTS	Clear to Send

Related Documentation

- [Interface Cable and Wire Specifications for the SRX240 Services Gateway on page 149](#)
- [RJ-45 Connector Pinouts for the SRX240 Services Gateway Ethernet Port on page 149](#)

APPENDIX D

Contacting Customer Support and Returning the SRX240 Services Gateway Hardware

This appendix includes the following topics:

- Return Procedure for the SRX240 Services Gateway on page 153
- Locating SRX240 Services Gateway Component Serial Number and Agency Labels on page 154
- Contacting Customer Support to Obtain Return Materials Authorization on page 155

Return Procedure for the SRX240 Services Gateway

Follow the tasks list provided in [Table 46 on page 153](#) to return an SRX240 Services Gateway or component to Juniper Networks for repair or replacement:

Table 46: Return Procedure for SRX240 Services Gateway

Step	Task	For more information, see
1	Determine the part number and serial number of the services gateway or component.	"Locating SRX240 Services Gateway Component Serial Number and Agency Labels" on page 154
2	Obtain a Return Materials Authorization (RMA) number from JTAC.	"Juniper Networks Technical Assistance Center" on page 106
3	Pack the SRX240 Services Gateway or component for shipping.	"Packing the SRX240 Services Gateway and Components for Shipment" on page 156



NOTE: Do not return the device or any component to Juniper Networks unless you have first obtained an RMA number. Juniper Networks reserves the right to refuse shipments that do not have an RMA. Refused shipments are returned to the customer via collect freight.

For more information about return and repair policies, see the customer support webpage at <http://www.juniper.net/support/guidelines.html>.

For product problems or technical support issues, open a support case using the Case Manager link at <http://www.juniper.net/support/> or call 1-888-314-JTAC (within the United States) or 1-408-745-9500 (outside the United States).

Related Documentation

- [Locating SRX240 Services Gateway Component Serial Number and Agency Labels on page 154](#)
- [Information You Might Need to Supply to Juniper Networks Technical Assistance Center on page 156](#)
- [Juniper Networks Technical Assistance Center on page 106](#)
- [Packing the SRX240 Services Gateway and Components for Shipment](#)

Locating SRX240 Services Gateway Component Serial Number and Agency Labels

This topic includes the following sections:

- [Listing the SRX240 Services Gateway and Component Details with the CLI on page 154](#)
- [SRX240 Services Gateway Chassis Serial Number and Agency Labels on page 155](#)
- [SRX240 Services Gateway Mini-Physical Interface Module Serial Number Label on page 155](#)

Listing the SRX240 Services Gateway and Component Details with the CLI

Before contacting Juniper Networks to request an RMA, you must find the serial number on the SRX240 Services Gateway or component.

To list all of the SRX240 Services Gateway components and their serial numbers, enter the following command-line interface (CLI) command:

```
user@host> show chassis hardware
Hardware inventory:
Item      Version  Part number  Serial number  Description
Chassis                AH1111AA7887  SRX240h-poe
Routing Engine REV 01   750-021794  PW7887        RE-SRX240-POE
FPC 0
  PIC 0                16x GE Base PIC
FPC 1    REV 01   750-025085  PW8534        FPC
  PIC 0                1x Serial mPIM
FPC 2    REV 00   750-032730
FPC 3    REV 06   750-025184  AAAN7005      FPC
  PIC 0                1x VDSL2 Annex A
Power Supply 0
```





NOTE: In the `show chassis hardware` command, the Mini-Physical Interface Module (Mini-PIM) slot number is reported as an FPC number, and the Mini-PIM number (always 0) is reported as the PIC number.

Most components also have a serial number ID label attached to the component body.

SRX240 Services Gateway Chassis Serial Number and Agency Labels

The SRX240 Services Gateway has a serial number ID label and an agency label located on the back of the chassis as shown in [Figure 26 on page 155](#).

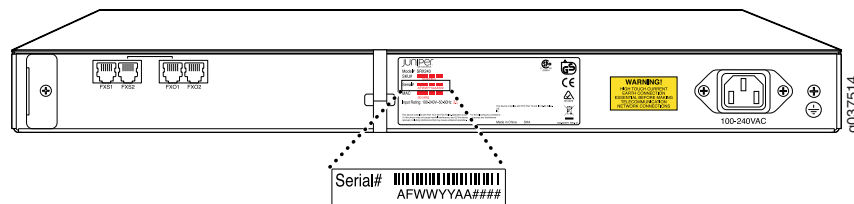
Figure 26: Location of SRX240 Serial Number and Agency Labels



SRX240 Services Gateway Mini-Physical Interface Module Serial Number Label

Mini-Physical Interface Modules (Mini-PIMs) are field-replaceable on the SRX240 Services Gateway. Each Mini-PIM has a unique serial number. The serial number label is located on the right side of the Mini-PIM, when the Mini-PIM is horizontally oriented (as it would be installed on the device).

The exact location might be slightly different on different Mini-PIMs, depending on the placement of components on the Mini-PIM.

Related Documentation

- [Packing the SRX240 Services Gateway and Components for Shipment on page 156](#)
- [Return Procedure for the SRX240 Services Gateway on page 153](#)
- [Information You Might Need to Supply to Juniper Networks Technical Assistance Center on page 156](#)

Contacting Customer Support to Obtain Return Materials Authorization

This topic includes the following sections:

- [Information You Might Need to Supply to Juniper Networks Technical Assistance Center on page 156](#)
- [Juniper Networks Technical Assistance Center on page 156](#)
- [Packing the SRX240 Services Gateway and Components for Shipment on page 156](#)

Information You Might Need to Supply to Juniper Networks Technical Assistance Center

If you are returning a services gateway or hardware component to Juniper Networks for repair or replacement, obtain a Return Materials Authorization (RMA) number from Juniper Networks Technical Assistance Center (JTAC).

When requesting support from JTAC by telephone, be prepared to provide the following information:

- Your existing case number, if you have one
- Details of the failure or problem
- Type of activity being performed on the services gateway when the problem occurred
- Configuration data displayed by one or more **show** commands
- Your name, organization name, telephone number, fax number, and shipping address

Related Documentation

- [Return Procedure for the SRX240 Services Gateway on page 153](#)
- [Locating SRX240 Services Gateway Component Serial Number and Agency Labels on page 154](#)
- [Packing the SRX240 Services Gateway and Components for Shipment on page 156](#)
- [Juniper Networks Technical Assistance Center on page 106](#)

Juniper Networks Technical Assistance Center

If you need assistance while troubleshooting a services gateway, open a support case using the Case Manager link at <http://www.juniper.net/support/>, or call 1-888-314-JTAC (within the United States) or 1-408-745-9500 (from outside the United States).

Related Documentation

- [Information You Might Need to Supply to Juniper Networks Technical Assistance Center on page 156](#)

Packing the SRX240 Services Gateway and Components for Shipment

This topic includes the following sections:

- [Packing the Services Gateway on page 157](#)
- [Packing the Components for Shipment on page 157](#)

Packing the Services Gateway

To pack the services gateway for shipment:

1. Retrieve the shipping carton and packing materials in which the services gateway was originally shipped. If you do not have these materials, contact your Juniper Networks representative about approved packaging materials.
2. Attach an electrostatic discharge (ESD) grounding strap to your bare wrist and connect the strap to the ESD point on the chassis or to an outside ESD point if the services gateway is disconnected from earth ground.
3. On the console or other management device connected to the services gateway, enter CLI operational mode and issue the following command to shut down the services gateway software:

```
user@host> request system power-off
```

Wait until a message appears on the console confirming that the operating system has halted.

4. Shut down power to the services gateway by pressing the Power button on the front panel of the services gateway.
5. Disconnect power from the services gateway.
6. Remove the cables that connect to all external services gateway.
7. Remove all field-replaceable units (FRUs) from the services gateway.
8. If the services gateway is installed on a rack, have one person support the weight of the services gateway while another person unscrews and removes the mounting screws.
9. Place the services gateway in the shipping carton.
10. Cover the services gateway with an ESD bag, and place the packing foam on top of and around the services gateway.
11. Replace the accessory box on top of the packing foam.
12. Securely tape the box closed.
13. Write the Return Materials Authorization (RMA) number on the exterior of the box to ensure proper tracking.

Packing the Components for Shipment

Follow these guidelines for packing and shipping individual components of the services gateway:

- When you return a component, ensure that it is adequately protected with packing materials and packed so that the pieces are prevented from moving around inside the carton.
- Use the original shipping materials if they are available.

- Place individual Mini-Physical Interface Modules (Mini-PIMs) in electrostatic bags.
- Write the Return Materials Authorization (RMA) number on the exterior of the box to ensure proper tracking.



.....
CAUTION: Do not stack any of the services gateway components during packing.
.....

Related Documentation

- [Required Tools and Parts for Installing and Maintaining the SRX240 Services Gateway on page 39](#)
- [Locating SRX240 Services Gateway Component Serial Number and Agency Labels on page 154](#)
- [Information You Might Need to Supply to Juniper Networks Technical Assistance Center on page 156](#)
- [SRX240 Services Gateway General Safety Guidelines and Warnings on page 111](#)
- [Return Procedure for the SRX240 Services Gateway on page 153](#)
- [Juniper Networks Technical Assistance Center on page 106](#)

PART 5

Index

- [Index on page 161](#)

Index

Symbols

#, comments in configuration statements.....	xi
(), in syntax descriptions.....	xi
< >, in syntax descriptions.....	xi
[], in configuration statements.....	xi
{ }, in configuration statements.....	xi
(pipe), in syntax descriptions.....	xi

A

AC input line frequency.....	145
AC input voltage.....	145
AC system current rating.....	145
Accessory parts list.....	42
acoustic noise.....	141
agency approvals.....	138
agency labels.....	154
air filter, replacing.....	90
airflow	34
Alarm LED.....	14
approvals, agency.....	138
autoinstallation.....	61
use of built-in Ethernet ports.....	72

B

back panel.....	9
blank faceplate, removing.....	47
boot devices.....	18
braces, in configuration statements.....	xi
brackets	
angle, in syntax descriptions.....	xi
square, in configuration statements.....	xi
building structure.....	33

C

CAT-5e.....	149
clearance requirements.....	34
CLI	
configuring services gateway with.....	78
comments, in configuration statements.....	xi

compliance	
EMC requirements.....	139
general standards.....	138
compliance statements for EMC requirements	
Israel.....	139
configuration	
factory default.....	72
use of built-in Ethernet ports.....	72
using the CLI.....	78
using the setup wizard.....	75
connecting to	
CLI locally.....	64
CLI remotely.....	64
power.....	49
setup wizard.....	63
console port, RJ-45.....	151
conventions	
notice icons.....	ix
text and syntax.....	x
cooling system.....	21
curly braces, in configuration statements.....	xi
customer support.....	xii, 153
contacting JTAC.....	xii

D

DC input voltage.....	146
DC power cable.....	146
DC system current rating.....	146
default	
built-in Ethernet interface configuration.....	72
security policy configuration.....	72
security zone configuration.....	72
documentation.....	xi

E

electrical and power requirements.....	35
electricity safety warnings.....	130
electromagnetic compatibility.....	144
electrostatic discharge damage.....	111, 114
EMC (EMI)	
compliance with requirements.....	139
standards.....	138
EMC requirements	
Israel.....	139
encrypted access	
through HTTPS.....	85
through SSH.....	74
through SSL.....	85

Ethernet cable, connecting the services gateway to a management device.....	63
Ethernet port	
autoinstallation	72
chassis cluster.....	72
factory default configuration.....	72
initial configuration.....	72
RJ-45.....	150
F	
factory default configuration.....	72
fans.....	21
fire safety specifications.....	115
flange holes.....	33
font conventions.....	x
front panel.....	9
G	
Gigabit Ethernet port.....	12
grounding.....	49
cable, amperage.....	147
lug.....	147
H	
HA LED.....	14
hardware features.....	5
HTTP (Hypertext Transfer Protocol)	
on built-in management interfaces.....	85
HTTPS (Hypertext Transfer Protocol over SSL)	
recommended for secure access.....	85
I	
immunity standards.....	138
interfaces.....	12
internal flash.....	18
J	
JTAC.....	106, 153, 156
L	
laptop See management device	
laser safety guidelines.....	121
LEDs.....	14
safety warnings.....	121
lithium battery.....	140
M	
maintenance guidelines	
warnings.....	125
management device	
connecting to CLI.....	64
connecting to setup wizard.....	63
manuals,	
list of	xi
Mini-PIM	
description.....	23
installing.....	47
LED.....	14
removing.....	47
slots.....	12
monitoring	
alarm conditions.....	101
CLI.....	95
LEDs.....	97
power system.....	103
mounting brackets.....	33
N	
NEBS standards.....	138
notice icons.....	ix
O	
overview, installation.....	37
P	
parentheses, in syntax descriptions.....	xi
parts list	
3-prong power cord.....	41
chassis.....	41
DB-9 to RJ-45 adapter	
straight through, 7 feet.....	41
rack mounting kit.....	41
PC See management device	
PoE.....	25
classes and power ratings.....	26
supported ports.....	25
supported standards.....	25
PoE Status LED.....	16
port LEDs	
TX/RX/Link and POE.....	16
port settings.....	67
power.....	49
powering on.....	57
shutting down.....	57
Power LED.....	14
Power over Ethernet.....	25

R

rack requirements.....	33
radio frequency interference.....	144
regulatory compliance.....	109
replacing the air filter.....	90
Reset Config button.....	105
Return Materials Authorization (RMA).....	153
RMA.....	153
<i>See also</i> Return Materials Authorization	
RS-232 (EIA-232)	149

S

safety.....	109
requirements.....	43
standards.....	138
warning levels.....	109
secure access	
CLI requirements.....	74
HTTPS recommended.....	85
Telnet versus SSH.....	74
Secure Sockets Layer <i>See</i> SSL	
serial number.....	154
setup wizard	
connecting to.....	63
default setup mode.....	76
description.....	75
guided setup mode.....	76
performing initial configuration with.....	75
running.....	77
show chassis alarms.....	95
show chassis environment.....	95
show chassis fpc.....	95
show chassis hardware.....	95
shutdown	
graceful.....	57
immediate.....	57
signaling limitations.....	144
site preparation checklist.....	31
specifications	
fire safety.....	115
SRX240 Services Gateway	
configuration with setup wizard.....	75
description.....	3
establishing secure Web access.....	85
factory default configuration.....	72
grounding	
specifications.....	147
HTTPS Web access.....	85
initial configuration.....	71

installation.....	44
installation preparation.....	43
maintenance procedures.....	89
monitoring.....	95
packing.....	156
power	
specifications.....	145
power supply.....	57
powering off.....	57
powering on.....	57
returning.....	153
safety requirements.....	43
shipment.....	156
specifications.....	7
SSH access.....	74
SSL access.....	85
troubleshooting.....	95
unpacking.....	41
SSL (Secure Sockets Layer)	
management access.....	85
standards compliance.....	138
Status LED.....	14
support, technical <i>See</i> technical support	
syntax conventions.....	x

T

technical publications list.....	xi
technical support	
contacting JTAC.....	xii
tools and parts	
antistatic mat.....	39
blank panels.....	39
electrostatic bag.....	39
ESD wrist strap.....	39
flat-blade screw-blade screwdriver.....	39
Phillips (+) screwdriver.....	39
socket wrench.....	39
tie wrap.....	39
TX/RX/Link LED.....	16

U

unpacking the services gateway.....	41
USB port.....	12
USB storage device.....	18

V

verifying received parts.....	41
-------------------------------	----

W

warnings

electrical.....	130
general.....	111
installation.....	116
laser and LED.....	121
maintenance and operational.....	125