



Quasar Gen III

User and Installation Guide

CF-6308 Box IP Camera



© 2017 FLIR Systems, Inc. All rights reserved worldwide. No parts of this manual, in whole or in part, may be copied, photocopied, translated, or transmitted to any electronic medium or machine readable form without the prior written permission of FLIR Systems, Inc.

Names and marks appearing on the products herein are either registered trademarks or trademarks of FLIR Systems, Inc. and/or its subsidiaries. All other trademarks, trade names, or company names referenced herein are used for identification only and are the property of their respective owners. This product is protected by patents, design patents, patents pending, or design patents pending. The contents of this document are subject to change.

FLIR Systems, Inc.
6769 Hollister Avenue
Goleta, California 93117
USA
Phone: 888.747.FLIR (888.747.3547)
International: +1.805.964.9797

For technical assistance, please call us at +1.888.388.3577 or visit the Service & Support page at www.flir.com/security.

Important Instructions and Notices to the User:

Modification of this device without the express authorization of FLIR Commercial Systems, Inc. may void the user's authority under FCC rules to operate this device.

Proper Disposal of Electrical and Electronic Equipment (EEE)



The European Union (EU) has enacted Waste Electrical and Electronic Equipment Directive 2012/19/EU (WEEE), which aims to prevent EEE waste from arising; to encourage reuse, recycling, and recovery of EEE waste; and to promote environmental responsibility.

In accordance with these regulations, all EEE products labeled with the “crossed out wheeled bin” either on the product itself or in the product literature must not be disposed of in regular rubbish bins, mixed with regular household or other commercial waste, or by other regular municipal waste collection means. Instead, and in order to prevent possible harm to the environment or human health, all EEE products (including any cables that came with the product) should be responsibly discarded or recycled.

To identify a responsible disposal method nearby, please contact the local waste collection or recycling service, the original place of purchase or product supplier, or the responsible government authority in the area. Business users should contact their supplier or refer to their purchase contract.

Document History

Version	Date	Comment
Ver. 1	May 21, 2017	Initial FLIR release



Table of Contents

1. Document Scope and Purpose	1
2. Introduction	7
2.1 Features	7
2.2 Package Contents	8
3. Hardware Description	9
4. System Requirements	11
5. Installation	13
5.1 Pre-Installation Checklist	13
5.2 Attaching and Adjusting the Lens	13
5.3 Powering the Camera	14
5.4 Connecting the Camera to the Network	15
5.5 Resetting the Camera	15
6. Using DNA to Access the Camera	17
7. Configuring the Unit's Initial IP Address	19
8. Configuring Communication Settings	23
9. Configuration and Operation	29
9.1 CF-6308 Web Interface	29
9.2 Live View	31
9.2.1 Recording	32
9.2.2 Capturing a Picture	32
9.2.3 Viewing Live Video from a Media Player	33
9.3 Settings	34
9.3.1 System Tab	35
9.3.2 Streaming Tab	71
9.3.3 Camera Tab	79
9.4 Logout	89
10. Appendices	91
10.1 Technical Specifications	92
10.2 Internet Security Settings on Internet Explorer	96
10.3 Installing UPnP Settings on Internet Explorer	98
10.4 Deleting Temporary Internet Files on Internet Explorer	101
10.5 Installing and Deleting the Web Player	102
10.6 Network Settings	107
10.7 Troubleshooting	108
10.8 Acronyms and Abbreviations	110

Table of Contents

10.9	Mounting and Lens Accessories	111
------	-------------------------------------	-----

1 Document Scope and Purpose

The purpose of this document is to provide instructions and installation procedures for physically connecting the CF-6308 unit. After completing the physical installation, additional setup and configurations are required before video analysis and detection can commence.



Note:

This document is intended for use by technical users who have a basic understanding of CCTV camera/video equipment and LAN/WAN network connections.

Remarque:

Ce document est destiné aux utilisateurs techniciens qui possèdent des connaissances de base des équipements vidéo/caméras de télésurveillance et des connexions aux réseaux LAN/WAN.



Warning:

Installation must follow safety, standards, and electrical codes as well as the laws that apply where the units are being installed.

Avertissement:

L'installation doit respecter les consignes de sécurité, les normes et les codes électriques, ainsi que la législation en vigueur sur le lieu d'implantation des unités.

Disclaimer

Users of FLIR products accept full responsibility for ensuring the suitability and considering the role of the product detection capabilities and their limitation as they apply to their unique site requirements.

FLIR Systems, Inc. and its agents make no guarantees or warranties to the suitability for the users' intended use. FLIR Systems, Inc. accepts no responsibility for improper use or incomplete security and safety measures.

Failure in part or in whole of the installer, owner, or user in any way to follow the prescribed procedures or to heed WARNINGS and CAUTIONS shall absolve FLIR and its agents from any resulting liability.

Specifications and information in this guide are subject to change without notice.

Avis de non-responsabilité

Il incombe aux utilisateurs des produits FLIR de vérifier que ces produits sont adaptés et d'étudier le rôle des capacités et limites de détection du produit appliqués aux exigences uniques de leur site.

FLIR Systems, Inc. et ses agents ne garantissent d'aucune façon que les produits sont adaptés à l'usage auquel l'utilisateur les destine. FLIR Systems, Inc. ne pourra être tenu pour responsable en cas de mauvaise utilisation ou de mise en place de mesures de sécurité insuffisantes.

Le non respect de tout ou partie des procédures recommandées ou des messages d'AVERTISSEMENT ou d'ATTENTION de la part de l'installateur, du propriétaire ou de l'utilisateur dégagera FLIR Systems, Inc. et ses agents de toute responsabilité en résultant.

Les spécifications et informations contenues dans ce guide sont sujettes à modification sans préavis.



A **Warning** is a precautionary message that indicates a procedure or condition where there are potential hazards of personal injury or death.

***Avertissement** est un message préventif indiquant qu'une procédure ou condition présente un risque potentiel de blessure ou de mort.*



A **Caution** is a precautionary message that indicates a procedure or condition where there are potential hazards of permanent damage to the equipment and or loss of data.

***Attention** est un message préventif indiquant qu'une procédure ou condition présente un risque potentiel de dommages permanents pour l'équipement et/ou de perte de données.*



A **Note** is useful information to prevent problems, help with successful installation, or to provide additional understanding of the products and installation.

*Une **Remarque** est une information utile permettant d'éviter certains problèmes, d'effectuer une installation correcte ou de mieux comprendre les produits et l'installation.*



A **Tip** is information and best practices that are useful or provide some benefit for installation and use of FLIR products.

*Un **Conseil** correspond à une information et aux bonnes pratiques utiles ou apportant un avantage supplémentaire pour l'installation et l'utilisation des produits FLIR.*

General Cautions and Warnings

This section contains information that indicates a procedure or condition where there are potential hazards.

SAVE ALL SAFETY AND OPERATING INSTRUCTIONS FOR FUTURE USE.

Although the unit is designed and manufactured in compliance with all applicable safety standards, certain hazards are present during the installation of this equipment.

To help ensure safety and to help reduce risk of injury or damage, observe the following:

Précautions et avertissements d'ordre général

Cette section contient des informations indiquant qu'une procédure ou condition présente des risques potentiels.

CONSERVEZ TOUTES LES INSTRUCTIONS DE SÉCURITÉ ET D'UTILISATION POUR POUVOIR VOUS Y RÉFÉRER ULTÉRIEUREMENT.

Bien que l'unité soit conçue et fabriquée conformément à toutes les normes de sécurité en vigueur, l'installation de cet équipement présente certains risques.

Afin de garantir la sécurité et de réduire les risques de blessure ou de dommages, veuillez respecter les consignes suivantes:



Caution:

- The unit's cover is an essential part of the product. Do not open or remove it.
- Never operate the unit without the cover in place. Operating the unit without the cover poses a risk of fire and shock hazards.
- Do not disassemble the unit or remove screws. There are no user serviceable parts inside the unit.
- Only qualified trained personnel should service and repair this equipment.
- Observe local codes and laws and ensure that installation and operation are in accordance with fire, security and safety standards.

Attention:

- *Le cache de l'unité est une partie essentielle du produit. Ne les ouvrez et ne les retirez pas.*
- *N'utilisez jamais l'unité sans que le cache soit en place. L'utilisation de l'unité sans cache présente un risque d'incendie et de choc électrique.*
- *Ne démontez pas l'unité et ne retirez pas ses vis. Aucune pièce se trouvant à l'intérieur de l'unité ne nécessite un entretien par l'utilisateur.*
- *Seul un technicien formé et qualifié est autorisé à entretenir et à réparer cet équipement.*
- *Respectez les codes et réglementations locaux, et assurez-vous que l'installation et l'utilisation sont conformes aux normes contre l'incendie et de sécurité.*



Caution:

- Do not drop the camera or subject it to physical shock.
- Do not touch sensor modules with fingers. If cleaning is necessary, use a clean cloth with a bit of ethanol and wipe it gently. If the camera will not be used for an extended period of time, put on the lens cap to protect the sensor from dirt.
- Do not aim the camera lens at strong light, such as the sun or an incandescent lamp, which can seriously damage the camera.
- Make sure that the surface of the sensor is not exposed to a laser beam, which could burn out the sensor.
- If the camera will be fixed to a ceiling, verify that the ceiling can support more than 20 newtons (20-N) of gravity, or over three times the camera's weight.
- The camera should be packed in its original packing if it is reshipped.



Caution:

To avoid damage from overheating or unit failure, assure that there is sufficient temperature regulation to support the unit's requirements (cooling/heating). Operating temperature should be kept in the range -20° to 50°C (-4° to 122°F), with no more than 90% non-condensing humidity.

Attention:

Afin d'éviter tout dommage dû à une surchauffe ou toute panne de l'unité, assurez-vous que la régulation de température est suffisante pour répondre aux exigences de l'unité (refroidissement/chauffage). La température de fonctionnement doit être maintenue dans la plage (-20° à 50°C / -4° à 122°F), sans condensation d'humidité supérieur à 90%.

Site Preparation

There are several requirements that should be properly addressed prior to installation at the site. The following specifications are requirements for proper installation and operation of the unit:

- **Ambient Environment Conditions:** Avoid positioning the unit near heaters or heating system outputs. Avoid exposure to direct sunlight. Use proper maintenance to ensure that the unit is free from dust, dirt, smoke, particles, chemicals, smoke, water or water condensation, and exposure to EMI.
- **Accessibility:** The location used should allow easy access to unit connections and cables.
- **Safety:** Cables and electrical cords should be routed in a manner that prevents safety hazards, such as from tripping, wire fraying, overheating, etc. Ensure that nothing rests on the unit's cables or power cords.
- **Ample Air Circulation:** Leave enough space around the unit to allow free air circulation.
- **Cabling Considerations:** Units should be placed in locations that are optimal for the type of video cabling used between the unit and the cameras and external devices. Using a cable longer than the manufacturer's specifications for optimal video signal may result in degradation of color and video parameters.
- **Physical Security:** The unit provides threat detection for physical security systems. In order to ensure that the unit cannot be disabled or tampered with, the system should be installed with security measures regarding physical access by trusted and un-trusted parties.
- **Network Security:** The unit transmits over IP to security personnel for video surveillance. Proper network security measures should be in place to assure networks remain operating and free from malicious interference. Install the unit on the backbone of a trusted network.
- **Electrostatic Safeguards:** The unit and other equipment connected to it (relay outputs, alarm inputs, racks, carpeting, etc.) shall be properly grounded to prevent electrostatic discharge.

The physical installation of the unit is the first phase of making the unit operational in a security plan. The goal is to physically place the unit, connect it to other devices in the system, and to establish network connectivity. When finished with the physical installation, complete the second phase of installation, which is the setup and configuration of the unit.



2 Introduction

This User and Installation Guide is intended to help you physically install, configure settings for, and operate, the CF-6308 indoor/outdoor fixed box IP camera. The camera body includes a CS mount and is supplied without a lens. The body accepts P-Iris, DC-Iris, and manual iris lenses. The camera supports three streams with the following maximum resolutions (default configuration): 3840x2160 (UHD/4K) + 1920x1080 (Full HD 1080p) + 720x480/576 (D1) with H.265, H.264, or MJPEG compression (3840x2160 @ H.265/H.264 only). It also includes audio-in, audio-out, alarm-in, and alarm-out connections. The camera is powered by an 802.3af Power over Ethernet (PoE), 12VDC, or 24VAC connection. It includes a microSD card drive for storing recordings and snapshots.

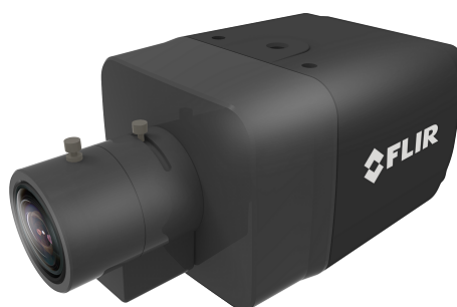

CF-6308 Box Camera

2.1 Features

- 4K (UHD) 1/2.8" Sony Exmor RS CMOS sensor
- DC-Iris, P-Iris, or Manual Iris
- Audio In/Out
- Low-lux mode without IR
- True and Digital WDR
- Built-in web server
- Motion detection event-driven alarms
- Gamma correction
- 802.1X and SSL/TLS security protocols
- RS-485 connection
- Triple stream: UHD + Full HD 1080p + D1
- One-push focus
- Alarm In/Out
- True day/night (ICR)
- 3DNR image noise reduction
- Supports Internet Explorer, Edge, Chrome, and Firefox browsers
- Tampering detection and notifications
- White balance
- SNMP v1/v2c/v3 and SNMP traps
- UPNP support
- H.265, H.264, and MJPEG compression
- External Auto Back Focus button
- External Default button
- Supports up to 32GB microSDXC card
- Backlight compensation
- HTTP streaming MJPEG
- Two regions of interest
- 8 privacy zones
- Up to 9 users
- ONVIF® support

- 4K (UHD) 1/2.8" Sony Exmor RS CMOS sensor
- Triple stream: UHD +Full HD 1080p + D1
- H.265, H.264, and MJPEG compression
- Powered by 802.3af PoE or optional 12VDC/24VAC supply
- IP66 enclosure with IK10 vandal-proof protection

2.2 Package Contents

The unit package contains the following items:

Quantity	Description
1	CF-6308 box camera
1	Two-pin female terminal connector for optional AC/DC power supply
1	Documentation and utilities CD
1	<i>CF-6308 Quick Install Guide</i>

Related Information:

- *DNA 2.1 User Manual*

3 Hardware Description

Following are the CF-6308 box camera's dimensions.

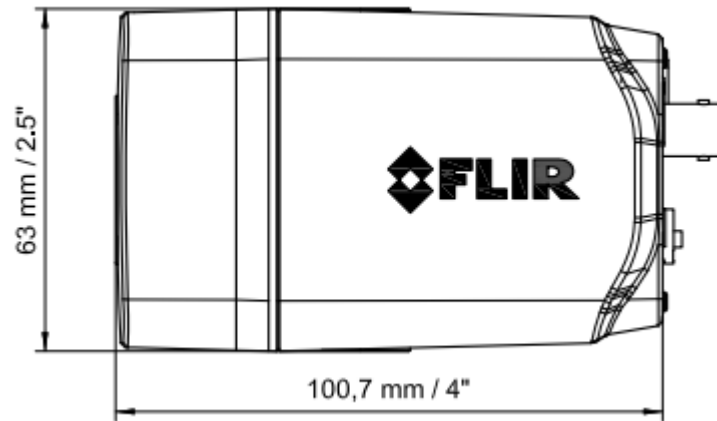

Side View

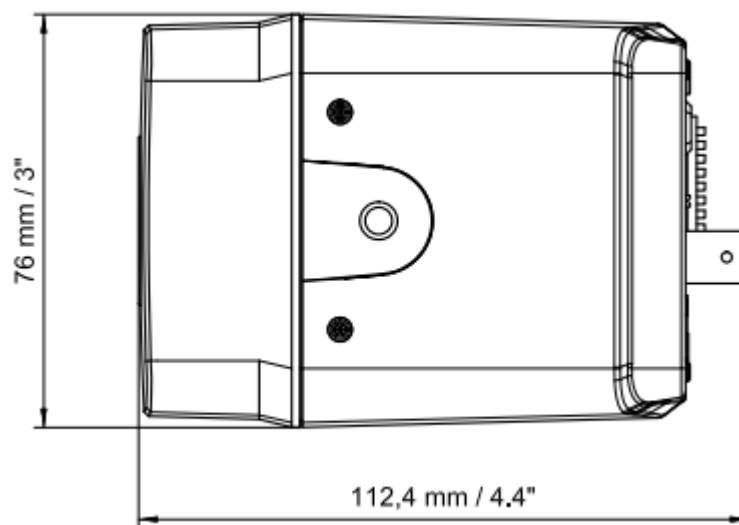

Top View

The connector panel includes the following:

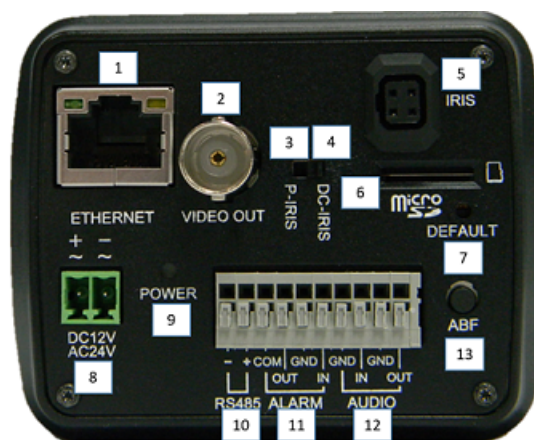

CF-6308 Connector Panel

Item	Legend	Description
1	ETHERNET	RJ45 port for Network and Power over Ethernet (PoE) connection.
2	VIDEO OUT	BNC connector for analog video outout.
3	P-IRIS	Move toggle switch to left side to enable use of P-Iris lens.
4	DC-IRIS	Move toggle switch to right side to enable use of DC-Iris lens.
5	IRIS	Connector for attaching cable from lens.
6	microSD	microSD card drive supporting microSDXC card (up to 32GB). The card is not included.
7	DEFAULT	Button to reboot the unit to full factory defaults. Network settings are not saved.
8	DC12V/AC24V	Male two-pin terminal block connector for attaching optional 12VDC or 24VAC power supply.
9	POWER	LED indicating Power On. The LED flashes green to indicate power on and network activity. The link is not illuminated if there is no network activity.
10	RS485	Spring input terminals on terminal block for Positive (+) and Negative (-) wires from device attached via RS-485 serial connection.
11	ALARM	Spring input terminals on terminal block for COM, Ground, Alarm In, and Alarm Out wires.
12	AUDIO	Spring input terminals on terminal block for two Ground, Alarm In, and Alarm Out wires.
13	ABF	Press the button to activate Auto Back Focus. This button activates the One-Push AF feature on the System >Lens Control screen.

4 System Requirements

Item	Minimum System Requirement
Personal Computer	Intel® Pentium® IV, 2.4GHz or higher with >1GB RAM Monitor display with minimum 1024 x 768 resolution (NVIDIA GeForce 6 Series or ATI Mobility Radeon 9500)
Operating System	Windows 7, 8, 8.1, and 10 (all 64-bit versions) Windows Server 2003, Windows Server 2008 (32-bit version)
Web Browser	Microsoft Internet Explorer 10 and above (32-bit version); Microsoft Edge 38 and above; Chrome v.55 and above; Firefox v.50 and above
Network Card	10Base-T (10 Mbps) or 100Base-TX (100 Mbps) operation
Viewer	ActiveX control plug-in for Internet Explorer; MJPEG viewer for Edge, Chrome, and Firefox



5 Installation

This section describes how to install and connect the unit. It includes the following topics:

- [Pre-Installation Checklist](#)
- [Powering the Camera](#)
- [Connecting the Camera to the Network](#)
- [Resetting the Camera](#)

5.1 Pre-Installation Checklist

Before installing the unit, make sure that:

- Instructions in the [Document Scope and Purpose](#) section are followed.
- All related equipment is powered off during the installation.
- Use best security practices to design and maintain secured camera access, communications infrastructure, tamper-proof outdoor boxes, etc.
- All electrical work must be performed in accordance with local regulatory requirements.

**Caution:**

To avoid damage from overheating or unit failure, assure that there is sufficient temperature regulation to support the unit's requirements (cooling/heating). Operating temperature should be kept in the range -20° to 50°C (-4° to 122°F), with no more than 90% non-condensing humidity.

Attention:

Afin d'éviter tout dommage dû à une surchauffe ou toute panne de l'unité, assurez-vous que la régulation de température est suffisante pour répondre aux exigences de l'unité (refroidissement/chauffage). La température de fonctionnement doit être maintenue dans la plage (-20° à 50°C/-4° à 122°F), sans condensation d'humidité supérieur à 90%.

5.2 Attaching and Adjusting the Lens

The camera is shipped without a lens. You must attach and adjust the lens before viewing video.

To attach and adjust the lens

1. Remove the plastic insert covering the threaded camera lens mount. Do not touch the sensor or allow dust to accumulate in the lens mount.
2. If you are using a C-mount lens, screw a 5mm adapter ring into the C-Mount to convert it to a CS-Mount.
3. Align the lens threads into the lens mount and screw in the lens.
4. If you are using a DC auto iris lens, plug the auto iris cable from the lens assembly into the IRIS port of the camera.
5. When using a manual lens or a DC auto iris lens, verify that the P-Iris/DC-Iris toggle switch is in the DC-Iris position.

6. Adjust the lens on a close scene.
7. Press the ABF button on the connector panel to fine-tune the focus.

5.3 Powering the Camera

The camera can be powered by an 802.3af PoE (Class 3) connection over the unit's network cable, or by a two-pin terminal block connection to a 12VDC or 24VAC power supply (not supplied).

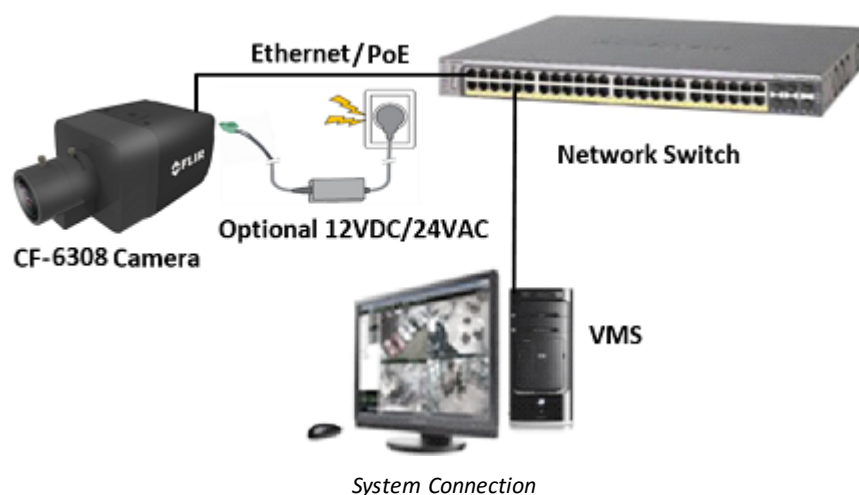

Caution:

1. If the camera is connected to a PoE network, note that the PoE supply's rated output is 48VDC, 0.2A.
2. If the camera is installed for outdoor use, the PoE supply must be installed with proper weatherproofing.
3. As a Listed Power Unit, the PoE should be marked as "LPS" or "Limited Power Source".
4. This product shall be installed by a qualified service person. Installation shall conform to all local codes.

Attention:

1. Si la caméra est connectée à un réseau PoE, notez que la puissance nominale de l'alimentation PoE est 48VDC, 0.2A.
2. Si la caméra est installée pour une utilisation extérieure, l'alimentation PoE doit être installée avec l'étanchéisation appropriée.
3. Comme une unité d'alimentation «Listed», le PoE doit être marqué comme «LPS» ou «Limited Power Source».
4. Ce produit doit être installé par un technicien qualifié. L'installation doit se conformer à tous les codes locaux.

5.4 Connecting the Camera to the Network

To view and configure the camera via a LAN, you must attach the camera via the network switch or router to the same subnet (network segment or VLAN) as the computer that manages the unit. If the PC is on a different subnet than the camera, you will not be able to access the camera via a web browser.

If there is a DHCP server on the network, it is recommended to use FLIR's Discovery Network Assistant (DNA) utility to search for and change the camera's initial IP address. If there is no DHCP server on the network, the camera will initialize with the default IP (192.168.0.250). You can then use DNA to change its IP address.

5.5 Resetting the Camera

The connector panel includes a **Default** button for easily resetting the camera. The button enables you to save configured settings and to restore factory defaults, including network settings.

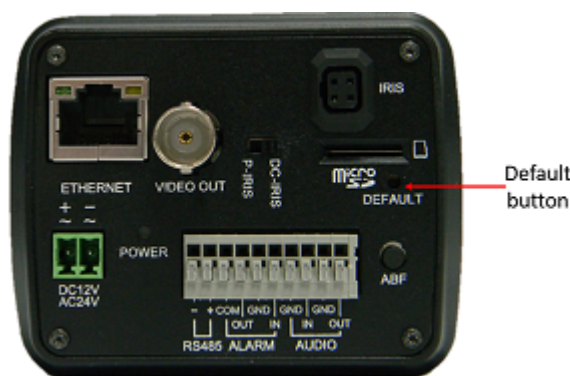

Default Button

To reboot the camera

1. Press the **Default** button for approximately five seconds. The unit reboots. Configured settings are saved.

To restore factory defaults

1. Press the **Default** button continuously for 30 seconds. The unit restores factory defaults, including network settings.



6 Using DNA to Access the Camera

To view and configure the camera via a LAN, you must attach the camera via the network switch or router to the same subnet (network segment or VLAN) as the computer that manages the unit. If the PC is on a different subnet than the camera, you will not be able to access the camera via a web browser.

If there is a DHCP server on the network, it is recommended to use FLIR's Discovery Network Assistant (DNA) utility to search for and change the camera's initial IP address.

DNA is a user-friendly utility that is designed to easily discover and configure FLIR Professional Security edge devices on a network. The DNA tool has a simple user interface and does not require any installation. The software is provided as a single, standalone executable. It runs on any PC.

DNA provides a central location for listing all the supported FLIR Professional Security camera models accessible over the network. Once listed, each camera can be right-clicked to access and change the network settings. If the network settings are changed for some reason, a new search will relist the units. The units may then be configured via the web interface.

If FLIR's Latitude VMS is being used, configure the unit with a static IP address rather than with DHCP. This ensures that the IP address will not automatically change in the future and interfere with configurations and communication.

If there is no DHCP server on the network, the camera will initialize with the default IP (192.168.0.250). You can then use DNA to change its IP address.



Note:

For detailed guidelines about DNA and its usage, refer to the *DNA 2.1 User Manual*, which is included in the CD provided with the camera.



7 Configuring the Unit's Initial IP Address

Use the FLIR DNA utility to discover the unit on the network and to set the unit's initial IP address.

- If the camera is located on a network that uses a DHCP server, or is managed by FLIR's Horizon or Meridian VMS and is configured as a DHCP server, configure the camera with *DHCP-enabled*. Horizon or Meridian automatically assigns the camera an IP address.
- If the camera is located on a network that does not use a DHCP server, or is managed by FLIR's Latitude VMS, manually enter its IP address in the DNA utility.



Note:

1. It is possible to set the IP address without changing the subnet.
2. The unit and the PC must be physically connected on the same network segment.

To manage the camera using Horizon, Meridian, or on a DHCP-enabled network

1. Insert the CD included in the package in your computer's disk drive.
2. Run the `dna.exe` file by clicking the  icon. The DNA application opens and the device is displayed in the window.

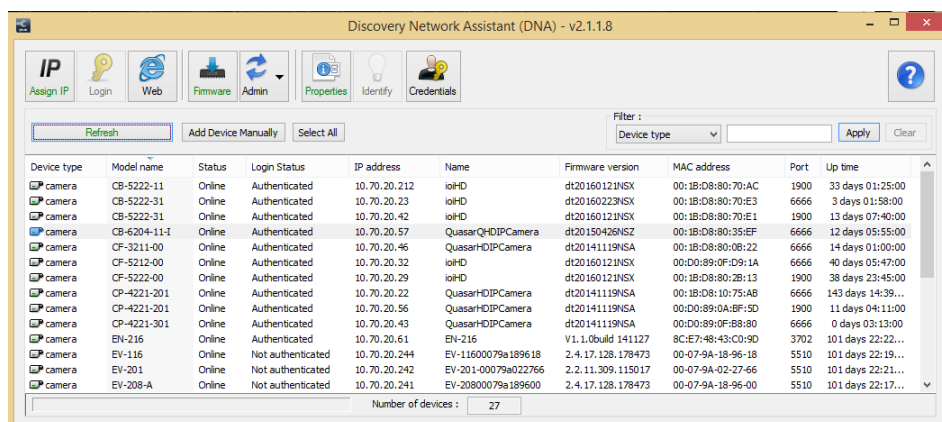

DNA Discovery Window

3. Click on the unit in DNA's Discover List. The CF-6308 **Login** window opens.

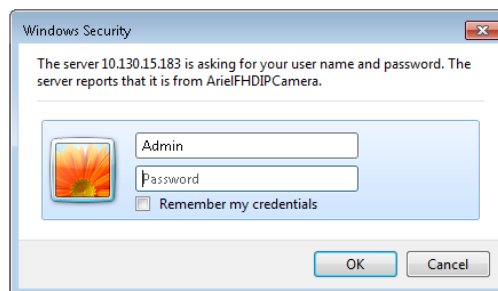

Login Window

4. If the camera cannot connect to a DHCP server, enter the unit's default IP address (192.168.0.250).
5. Enter the default User Name (*admin*) and Password (*admin*).



Note:

The user name and password are case-sensitive.

6. Click **Login**. The camera's web interface opens.
 - If your browser is Edge, Chrome or Firefox, the video is displayed in the [Live View](#) window.
 - If your browser is Internet Explorer, a message is displayed, requesting you to download the Microsoft Visual C++ 2008 Redistributable package and/or to install the Ariel Player add-on.

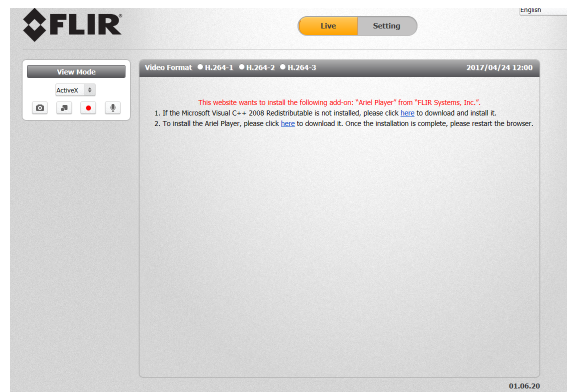

Web Interface with Internet Explorer Browser

- a. If the Microsoft Visual C++ 2008 Redistributable package is not installed in your computer, click the link to install it. Then proceed to Step 7.
 - b. If the Microsoft Visual C++ 2008 Redistributable folder is installed in your computer, proceed to Step 7.
7. Click "*here*" on the screen to download the Ariel Player add-on. The Ariel Player information bar opens.



Run Ariel Player Information Bar

When using Internet Explorer in closed networks, occasionally the browser will not install the Ariel Player on the client PC because it cannot verify the Ariel Player's digital signature. This may be because the local certificate is out of date, invalid or missing. The following message is displayed:



Corrupt/Invalid Signature

- a. Click **View downloads**. The **View Downloads** screen opens.

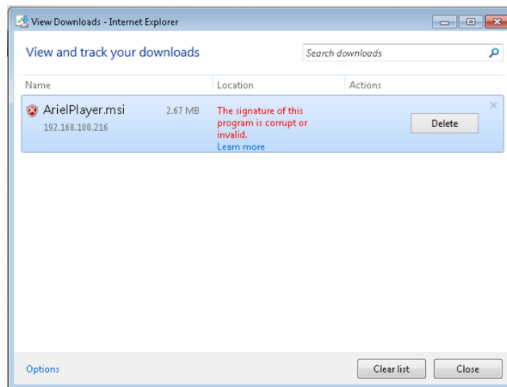

View Downloads Screen

- b. Right-click on the ArielPlayer.msi file.

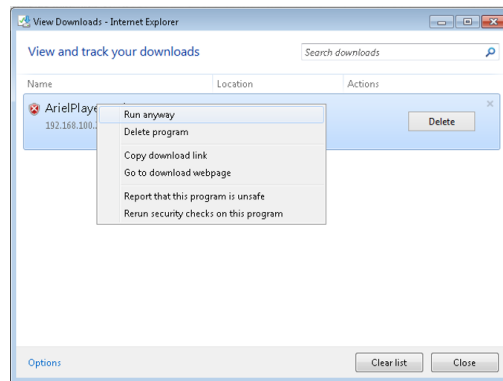

Run Anyway Option

- c. Select "Run anyway". The normal installation process starts.
8. Follow the instructions in [Appendix 10.5](#) for installing the Player. After installing the Player, the [Live View](#) is displayed.

To manage the camera using Latitude or on a network with static IP configuration

1. Insert the CD included in the package in your computer's disk drive.
2. Run the `dna.exe` file by clicking the  icon. The DNA application opens and the device is displayed in the **DNA Discovery** window. See Figure: [DNA Discovery Window](#).
3. Select the unit by right-clicking it. The **DNA - Assign IP** window is displayed.

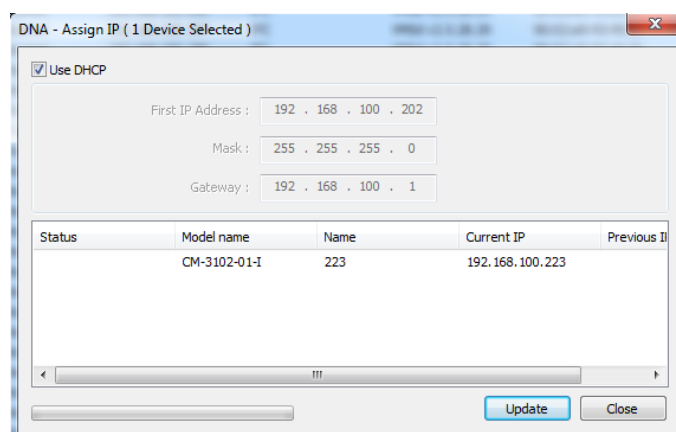

DNA Assign IP - Use DHCP Screen

4. Uncheck *Use DHCP*.
5. Enter the unit's default IP address (192.168.0.250), Subnet mask, and Gateway IP address in the respective field.
6. Click **Update**. The unit reboots with the new settings.
7. Click on the unit in DNA's Discover List. The camera's **Login** window opens. See Figure: [Login Window](#).
8. Enter the default User Name (*admin*) and Password (*admin*).



Note:
The user name and password are case-sensitive.

9. Click **Login**. The camera's web interface opens. See Figure: [Web Interface](#).
10. Click the on-screen message to install the Ariel Player plug-in. The Ariel Player Plug-in message is displayed. See Figure: [Ariel Player Plug-in Download Information Bar](#).

8 Configuring Communication Settings

To configure communication settings on the camera

1. Connect the camera to the network on the same VLAN/LAN as the workstation.
2. If the network supports the default, open the DNA utility by running `dna.exe` which can be found in the DNA utility folder in the supplied CD, or click the DNA icon .
3. In the DNA application, click the **DNA** button.
4. If the Windows Firewall is enabled, a security alert window pops up.
5. To continue, click **Allow Access**. Latitude users should consult the Latitude Installation Instructions on disabling the Windows Firewall.

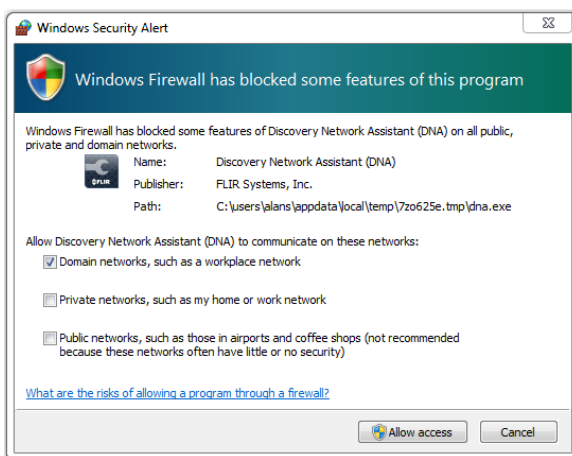

Windows Firewall Screen

6. Click **Assign IP**. All the discovered IP devices will be listed in the page, as shown in the figure below. The camera's default IP Address is automatically supplied by the DHCP server.

Device type	Model name	Status	Login Status	IP address	Name	Firmware version	MAC address	Port	Up time
camera	CB-5222-11	Online	Authenticated	10.70.20.39	ioHD	dt20160330NX	00:1B:D8:80:70:AF	6666	1 days 22:10:00
camera	CB-5222-11	Online	Authenticated	10.70.20.42	ioHD	dt20160330NX	00:1B:D8:80:AD:B7	6666	1 days 21:46:00
camera	CB-5222-31	Online	Authenticated	10.70.20.23	ioHD	dt20160330NX	00:1B:D8:80:70:E3	6666	2 days 04:14:00
camera	CF-3211-00	Online	Authenticated	10.70.20.57	QasarHDIPCamera	dt20141119NSA	00:1B:D8:80:08:22	6666	6 days 06:03:00
camera	CF-5222-00	Online	Authenticated	10.70.20.32	ioHD	dt20160121NX	00:1B:D8:80:28:13	1900	2 days 04:12:00
camera	CF-4221-201	Online	Authenticated	10.70.20.22	QasarHDIPCamera	dt20141119NSA	00:1B:D8:80:79:AB	6666	1 days 23:00:00
camera	CF-4221-201	Online	Authenticated	10.70.20.56	QasarHDIPCamera	dt20141119NSA	00:D0:89:0A:8F:5D	6666	6 days 06:06:00
camera	CF-4221-301	Online	Authenticated	10.70.20.43	QasarHDIPCamera	dt20141119NSA	00:D0:89:0F:88:80	6666	6 days 06:04:00
camera	EV-208-A	Online	Not authenticated	10.70.20.241	EV-20800079a189600	2.4.17.128.178473	00:07:9A:18-96-00	5510	4 days 05:17:04
camera	EV-216	Online	Not authenticated	10.70.20.243	EV-216-00079a188...	2.4.17.128.178473	00:07:9A:18-6A-82	5510	4 days 05:17:24

Discovered IP Devices

7. Right-click the camera whose network property is to be changed. From the context menu that opens, select **Assign IP**. The **Assign IP** dialog is displayed.

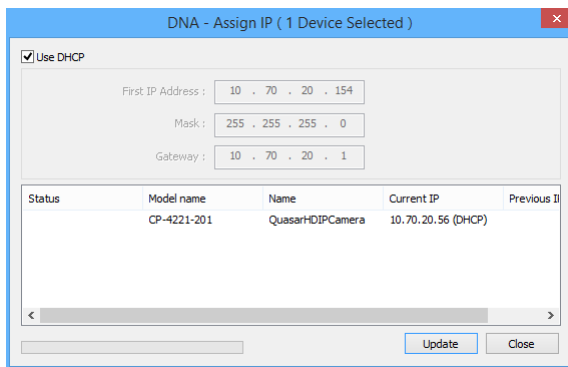

DNA Assign IP – Use DHCP Dialog Box

Tip:

Record the camera's MAC address for future reference.

8. To access DNA, do one of the following:
 - a. For DHCP (not supported by Latitude):
 - i. Select *Use DHCP*. Do not use for Latitude.
 - ii. Click **Update** and wait for status.
 - b. For Static IP (recommended for Latitude users):

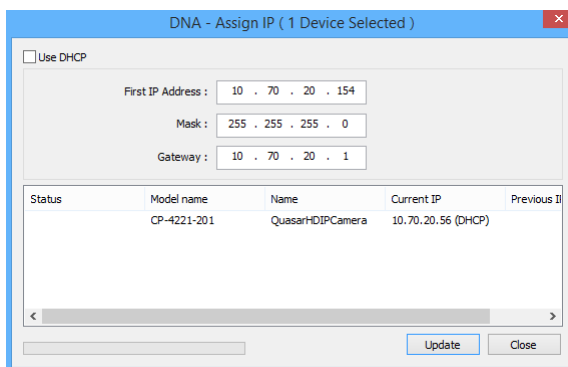

DNA Assign IP – Static IP Dialog Box

- i. Do not select the *Use DHCP* checkbox. This is recommended for security purposes and for Latitude users. In the IP Address, Gateway, and Netmask, enter the respective LAN/VLAN (optional DNS) values.
- ii. Click **Update** and wait for **OK** status to be displayed.

- Right-click and select **Web** to directly access the camera via a web browser. The web browser opens on the unit's **Login** dialog box.

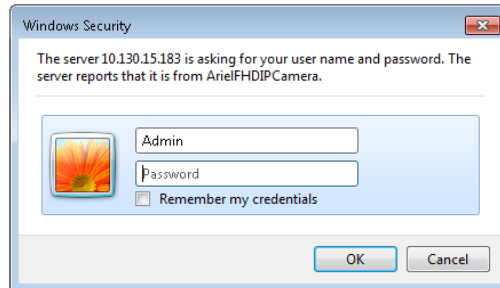

Login Dialog Box

- Log into the unit with the default user name *Admin* and password *1234*.



Note:

- Both the user name and password are case-sensitive.
 - It is strongly advised that administrator's password be altered for security reasons.
- If the **User Account Control** dialog box, opens and requests you to install the `install.cab` file, click **Yes**.
 - If the ActiveX installation is not successful after performing the previous step, in the Internet Explorer **Tools > Internet Options > Advanced Security** section, select the *Allow software to run or install even if the signature is invalid* checkbox. Uncheck the checkbox after installing ActiveX. Then click **OK**.

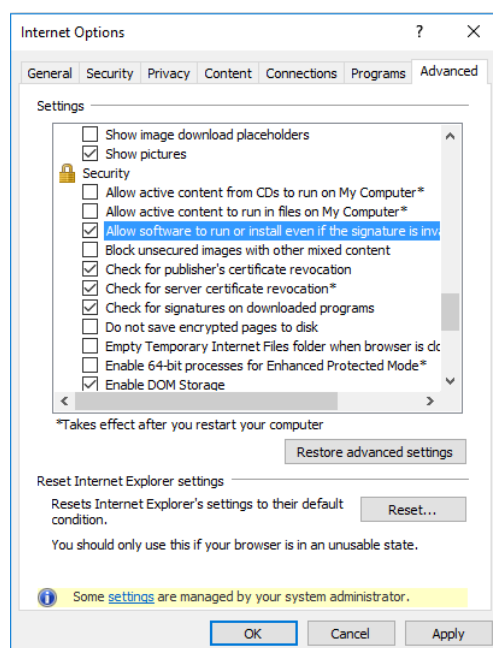

IE Tools > Internet Options > Advanced Window

- If you are using ActiveX, but do not have the Microsoft Visual C++ 2008 Redistributable libraries installed on your PC, the following error message is displayed. In this case, download and install the `vc_redist_x86.exe` file from the installation CD or from [FLIR Support](#).

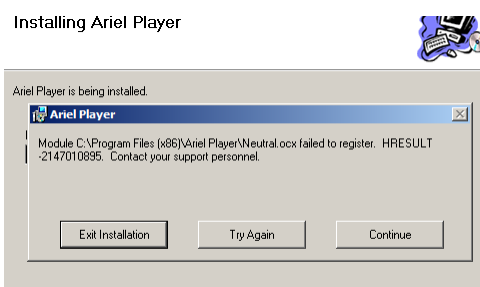

MS Visual C++ 2008 Redistributable Error Message

11. If a popup message appears for running the ActiveX add-on, click **Allow**.



Note:

If the password is changed and the Latitude AdminCenter Discovery feature is in use, deselect all other proprietary types. Select *FLIR* as the Unit Type so that the new password can be configured in the *Discovery > Add Unit Manually* setting.

Additionally, you can change the camera's network properties (either DHCP or Static IP) directly from the camera's web interface on the [System > Network > General](#) screen.

12. Install the web player.



Note:

If you have previously installed a web player application on the PC, you should delete the existing web player from the PC before accessing the camera.



9 Configuration and Operation

The Quasar Gen III camera is provided with a browser-based configuration interface for video playback and recording. In this chapter, information about main page introduction, system related settings and camera settings are described in detail.

Additionally, if FLIR's Latitude VMS is used, many of the configurations and features of FLIR's VMS provide configuration and automation of the camera.

This section includes the following information:

- [Accessing the CF-6308 via a Web Browser](#)
- [Live View](#)
- [System Tab](#)
- [Streaming Tab](#)
- [Camera Tab](#)
- [Logout](#)

9.1 CF-6308 Web Interface

The camera's web interface can be configured and operated from a 32-bit version of Internet Explorer 10 and above, Microsoft Edge 38 and above, Chrome v.55 and above, or Firefox v.50 and above.

To access the unit via the web browser

1. Open your browser.
2. Enter the unit's IP address in the browser's address bar.
3. Press the ENTER key on your PC keyboard. The unit's **Login** window is displayed. See Figure: [Login Window](#).
4. Enter the user name (default: *admin*) and password (default: *admin*) to log into the system. The unit's web interface opens. See Figure: [Web Interface](#).



5. If you are using the system for the first time or you have uploaded a new firmware version, click the message displayed on the screen to download to allow the `MediaPlayer Control Module.exe` plug-in.

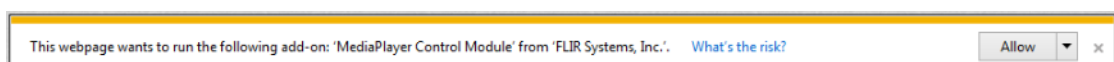

6. Click **Allow**. The Windows Installer opens and the **Ariel Player Wizard** dialog box is displayed. Follow instructions in the [Configuring the Unit's Initial IP Address](#) section.

7. Configure camera settings after setting the unit's IP address.

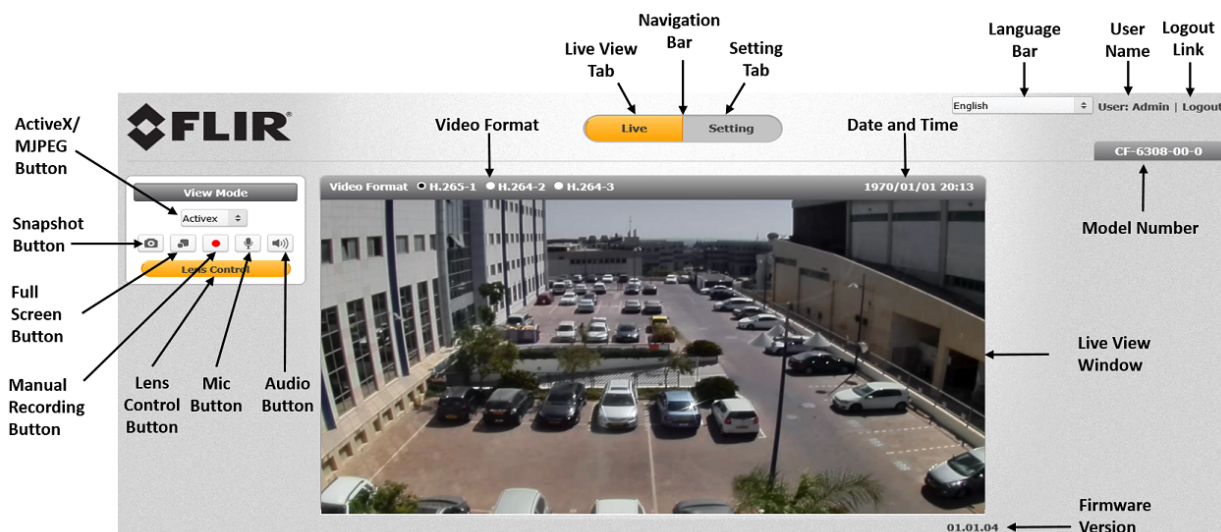



Live View Screen with Callouts on Internet Explorer Browser





The following information is displayed in the upper right fixed of the GUI:

- Language Bar – Select the language for the web interface: English, Arabic, Czech, Simplified Chinese, Traditional Chinese, French, German, Hungarian, Italian, Japanese, Polish, Portuguese, Russian, or Spanish.
- User Name – Displays the user name. By default, *Admin* is displayed.
- Logout Link– Click **Logout** to exit the web interface.
- Model Number – Displays the model number.

Above the **Live View** window, the selected video format, date and time are displayed. Below the **Live View** window, the firmware version is displayed.

To the left of the **Live View** window, the View Mode buttons are displayed. All buttons are displayed in Internet Explorer browsers. Only the **Snapshot** button is displayed in Microsoft Edge, Chrome, and Firefox.

Item	Description
ActiveX/MJPEG Button	Click ActiveX to use Internet Explorer or click MJPEG to using Chrome or Firefox. Displayed only with Internet Explorer browser.
Snapshot button	Click the  button to take a snapshot.
Full screen button	Click the  button to display the live view in full-screen mode. To switch back to Live View mode, right-click on the screen and click Normal Display , or press the ESC key on your keyboard. Displayed only with Internet Explorer browser.

Item	Description
Manual recording button	This button indicates the recording status: red when recording is On  or gray when recording is Off  . Displayed only with Internet Explorer browser.
Lens Control button	This button opens the Lens Control screen, on which you can set the focus (auto or manual) or reset the lens. Auto focus also can be set by pushing the ABF button on the connector panel.
Mic button	Click the Mic  button to listen to audio at the remote site. This function is available only to an Operator or Administrator. Click the button to switch it on/off. The button allows the user to listen to audio streaming over the web if (a) audio is enabled and (b) if an audio event is enabled and triggered by exceeding the threshold. See Audio . Displayed only with Internet Explorer browser.
Audio button	Click the audio button  to enable the playback of audio files and to hear audio-out over the web in the case of an audio event.

From the Navigation Bar, select one of these tabs:

- [Live](#) – Displays the **Live View** screen
- [Settings](#) – Displays the **Settings** sidebar

9.2 Live View

To start Live View

1. From the Navigation Bar, click **Live View**. The **Live View** screen opens.

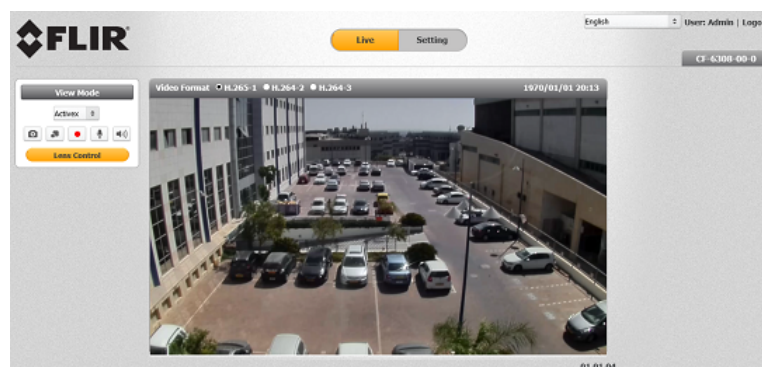

Live View Screen with Internet Explorer Browser

2. Click one of the buttons listed above for the desired action from the Live View toolbar.

The following sections include the following topics:

- [Recording](#)
- [Capturing a Picture](#)
- [Viewing Live Video from a Media Player](#)

9.2.1 Recording

Manual recordings (which are triggered from the **Live View** screen) are stored on the PC.

To start recording a Live View scene

1. Click the red **Manual Recording** icon  on the toolbar. The camera starts recording. A red dot is displayed in the upper right fixed of the **Live View** window, under the date and time display.



Note:

In order to save recordings on your PC, Internet Explorer should be run as Administrator.

2. Select the directory and folder to save the video, which is an `.avi` file.
3. Click the icon to stop recording. The icon turns gray .

To playback a Live View recording

1. Open the folder on the PC where the recording is stored.
2. Select the file.

Recordings that are triggered by events (such as motion detection) are stored on a microSDXC card, which can store up to 32GB of data. The card is not included.

To view a triggered event recording

1. In your browser, enter the camera's FTP address (ftp://camera_ip/).
2. Enter the Admin user name and password.
3. Open the folder for the event according to the type of event (motion detection, tampering, etc.). Files are displayed chronologically according to most recent date.
4. Select the file.

9.2.2 Capturing a Picture

It is possible to capture a picture as a snapshot in Live View mode and save it on your PC as a `.jpeg` or `.png` file image.



Note:

In order to save snapshots on your PC, Internet Explorer should be run as Administrator.

To capture a snapshot in Live View mode

1. In **Live View** mode, click the **Snapshot**  button on the toolbar to capture the live pictures.

To view a Live View snapshot

1. Open the folder on the PC where the snapshot is stored.
2. Select the file.

Snapshots that are triggered by events (such as motion detection) are stored on the camera's microSD card, which can store up to 64GB of data. The card is not included.

To view a triggered event snapshot

1. In your browser, enter the camera's FTP address (ftp://camera_ip/).
2. Enter the Admin's user name and password .
3. Open the folder for the snapshots. Files are displayed chronologically according to most recent date with an indication of the type of event, for example 20170118122205_motion_1.mp4.
4. Select the file.

9.2.3 Viewing Live Video from a Media Player

The Live View main stream and sub-stream can be viewed with a media player, such as VLC (download from <http://www.videolan.org/vlc/index.html>). Streams can be viewed for the three channels and two video encoding formats (H.264 and MJPEG).

The camera supports sending unicast and multicast streams via the RTSP protocol. Unicast streams include the suffix "stream" followed by the stream number without a space. Multicast streams include the suffix "streamXm", where "X" is the stream number (1, 2 or 3).

To view a media stream with VLC

1. Open VLC.
2. From the **Media** tab, select *Open Network Stream*. The **Open Media** screen is displayed.

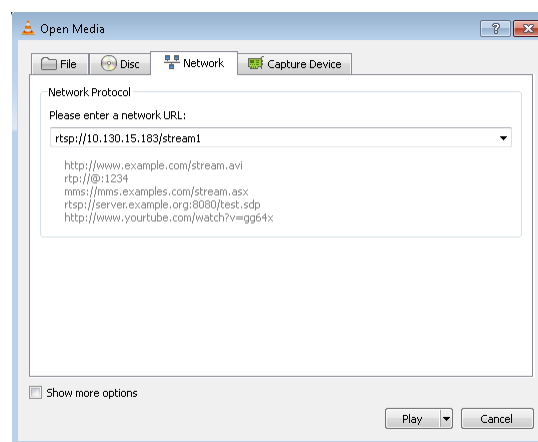

VLC Open Media Screen

3. In the **Network** tab, enter the URL for the stream in the address bar:
 - The syntax for entering the URL in the media player for the main stream is: `rtsp://(camera IP address)/(Unicast stream 1) or (Multicast stream 1)`. For example, `rtsp://192.168.0.250/stream1` for a unicast stream.
 - The syntax for entering the URL in the media player for the second stream is: `rtsp://(camera IP address)/(Unicast stream 2) or (Multicast stream 2)`. For example, `rtsp://192.168.0.250/stream2` for a unicast stream.
 - The syntax for entering the URL in the media player for the third stream is: `rtsp://(camera IP address)/(Unicast stream 3) or (Multicast stream 3)`. For example, `rtsp://192.168.0.250/stream3m` for a multicast stream.



Note:

1. It is also possible to change the syntax on the RTSP page, although this is not recommended if the camera is attached to a VMS.
2. Verify that the resolution entered in URL string agree with the resolution set in the [Streaming > Video Settings](#) screen.

4. Click **Play**. The video stream is displayed in the media player. If available, audio will also be streamed.

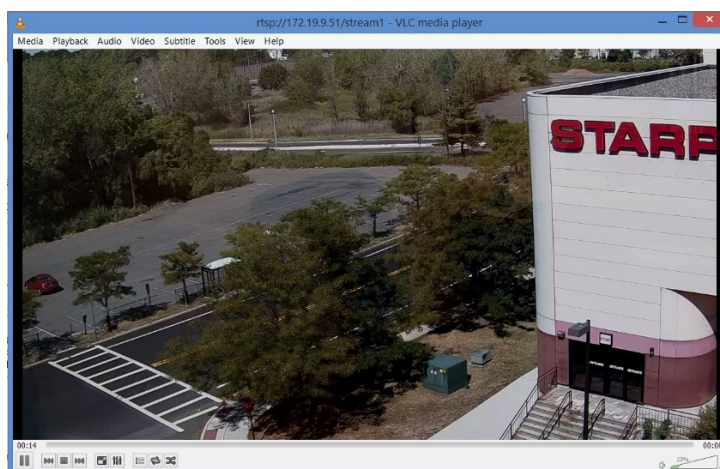

Media Player Screen

9.3 Settings

Device and client PC parameters are set from the **Settings** tab in the navigation bar. Upon clicking **Settings**, the **Settings** menu is displayed in the sidebar. Three sections are displayed: [System](#), [Streaming](#), and [Camera](#).

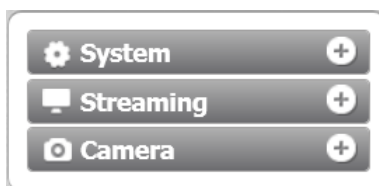

Unexpanded Sidebar

9.3.1 System Tab

The **System** tab is used for configuring essential system settings. Click the **System** tab to expand the menu.

The CF-6308 includes the following *System* menu:

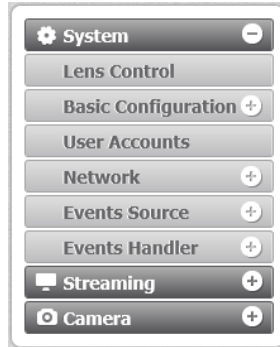

CF-6308 System Menu

Click the link to open the tabs for the various functions:

[Lens Control](#)

[Basic Configuration](#)

[User Accounts](#)

[Network](#)

[Events Source](#)

[Events Handler](#)

9.3.1.1 Lens Control

The **Lens Control** screen enables control of the focus functions.

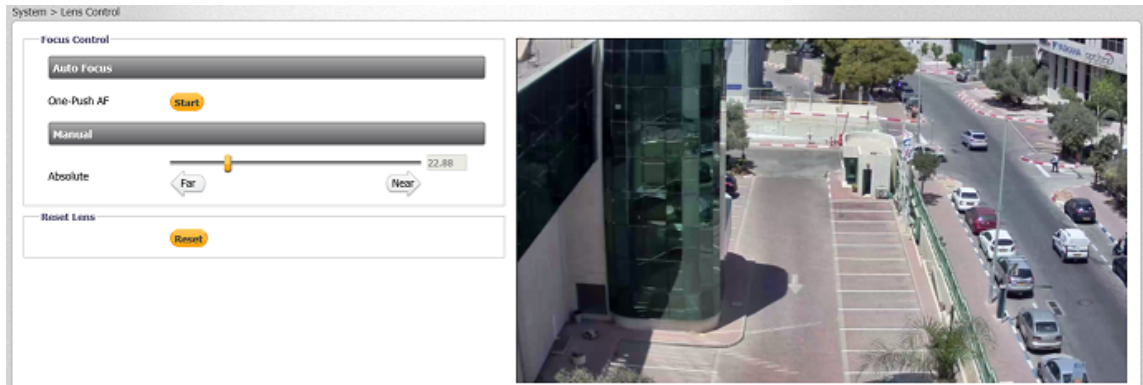

Lens Control Screen

To set Auto Focus

1. In the *Focus Control* section, click **Start**. Auto Focus is adjusted.



Note:

In very extreme cases, it may be necessary to manually re-zoom the camera and focus it again.

To manually set the focus

1. In the *Focus Control* section, move the slider to the desired focus between *Far* (1) to *Near* (100).
2. From the *Step* drop-down list, select the number of steps to set the focus: 1, 2, 4, 8, 16, 32, 64, or 128.

To revert to the previous settings (To reset the lens)

1. In the *Reset Lens* section, click **Reset**. The previous settings are restored.



Note:

After clicking the **Reset** button in the *Reset Lens*, it is necessary to click the **Start** button in the *Focus Control* section to refocus the lens.

9.3.1.2 Basic Configuration

The **Basic Configuration** tab includes the following screens:

- [Date & Time](#)
 [Audio](#)
 [Firmware](#)
 [Basic Operations](#)
 [OSD](#)

9.3.1.2.1 Date & Time

The current time is displayed in the *Current Camera Time* text box. To set the date and time, select **Basic Configuration > Date & Time**. The **Date & Time** screen is displayed.

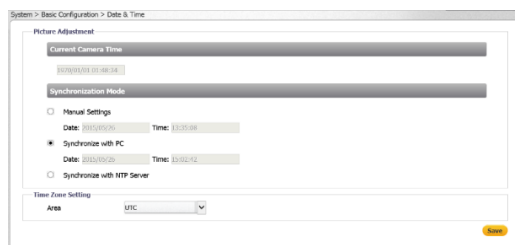

Date & Time Screen

To change the date and time

1. Select one of the following options
 - *Manual Settings* – Enter the date and time in the respective field.
 - *Synchronize with PC* – Enter the date and time in the respective field.
 - *Synchronize with NTP Server* – Selecting this option opens the *NTP Settings* section:

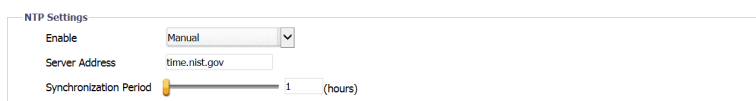

NTP Setting Section

- a. Enter the following details in the *NTP Setting* section:
 - *Enable* – From the drop-down list, select *Manual* to set the NTP server manually, or *From DHCP Server* to set the time according to the network DHCP server.
 - *Server Address* – Enter the IP address for the NTP server.
 - *Synchronization Period* – Select a number between 1-24 for the frequency (in number of hours) that the camera will synchronize with the NTP time server (i.e., every one hour, every two hours, etc.).
2. In the *Time Zone Setting* section, from the *Area* drop-down list, select your local time zone.
3. Click **Save**. The new time is displayed in the *Current Camera Time* text box.

9.3.1.2.2 Audio

The **Audio** screen is used for configuring *Audio In* and *Audio Out* settings.

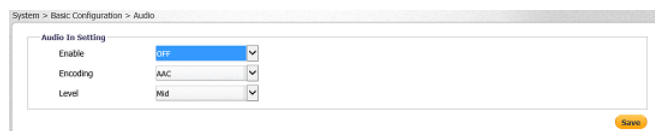

Basic Configuration > Audio Screen

To enable audio settings

1. From the *Enable* drop-down list, select *ON*.
2. From the *Encoding* drop-down list, select *G.711 a-law*, *G.711 μ -law*, or *AAC*. The default is *AAC*.
3. From the *Level* drop-down list, select *High*, *Mid*, or *Low*.

9.3.1.2.3 Firmware

The **Firmware** screen displays and is used to update the system firmware, and to display the hardware version, product name (model number), product serial number, and product MAC address. To access the **Firmware** screen, select **Basic Configuration > Firmware**.

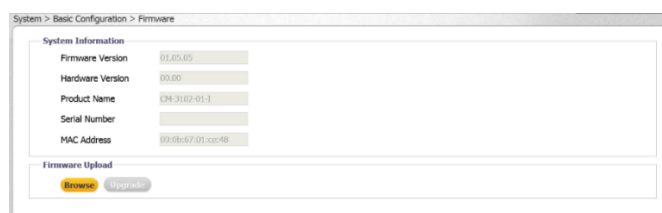

Firmware Screen

To update system firmware

1. Click **Browse** to locate the firmware file.
2. Select the file. The file name is displayed (for example, *ArielFHD_20161230*).
3. Click **Upgrade**. The upgrade process takes about three minutes. After the firmware has upgraded successfully, the camera reboots.

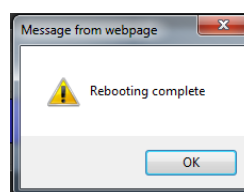

Rebooting Complete Dialog Box

4. Click **OK**. The **Live** screen opens.
5. If your browser requests you to close the window, click **Yes**. The window closes.
6. Open a new window and enter the camera's URL. The **Login** window opens. See Figure: [Login Window](#).
7. Enter your user credentials and log into the camera. The new firmware version is displayed in the *Firmware Version* text box.

9.3.1.2.4 Basic Operations

The **Basic Operations** screen is used for the following functions:

- Setting the TV format
- Setting the video out aspect ratio – Ensures that the video image is displayed correctly on the video monitor without distortion or a black border on the edge
- Importing settings from another unit
- Exporting settings to another unit
- Rebooting the camera – Saves configured settings
- Restoring partial factory defaults – Restores factory defaults, but retain network settings (IP address, netmask address, and gateway address), TV format, and image rotation settings
- Restoring full factory defaults – Restores factory defaults, including network settings



Basic Operations Screen

To take the above actions, from the **Basic Configuration** tab, select the **Basic Operations** tab.

To select the TV format

1. From the drop-down list, select *NTSC* or *PAL*. The default is *NTSC*.

To set the aspect ratio of the video out signal

1. From the *TV Out* drop-down menu, select one of the following:
 - Full – This sets the video stream to D1 and ensures that the video image completely fills the monitor display, regardless of its aspect ratio.
 - 4:3 – Select this configuration if the video monitor is set to 4:3 aspect ratio.
 - 16:9 – Select this configuration if the video monitor is set to 16:9 aspect ratio.

To import a setting

1. Click **Browse** to select the file.
2. Click **Import** to upload the file.

To export a setting

1. Click **Export**. An information bar opens.
2. Click **Save** in the information bar to save the file.

To reboot the camera

1. Click **Reboot**. The camera reboots. After the reboot finishes, a popup window opens with the message “Rebooting complete”.
2. Click **OK**. A dialog box opens, requesting you to close the tab in your browser.
3. Close the tab.
4. Open a new tab in your browser, and re-enter the camera’s IP address. The camera’s **Login** window opens.
5. Enter your login credentials. The camera’s home page opens.

To restore partial factory defaults

1. Click **Partial factory defaults**. The camera reboots. After the reboot finishes, a popup window opens with the message “Rebooting complete”.

**Note:**

Clicking **Partial factory defaults** restores all factory defaults except network settings

2. Click **OK**. A dialog box opens, requesting you to close the tab in your browser.
3. Close the tab.
4. Open a new tab in your browser, and re-enter the camera’s IP address. The camera’s **Login** window opens.
5. Enter your login credentials. The camera’s home page opens.

To restore full factory defaults

1. Click **Full factory defaults**. The camera reboots. After the reboot finishes, a popup window opens with the message “Rebooting complete”.



Note:

1. Selecting **Full factory defaults** causes the camera to lose all network settings.
2. Since the unit’s IP address might change when restoring full factory defaults, it is recommended to use DNA to discover the unit after rebooting.

2. Click **OK**. A dialog box opens, requesting you to close the tab in your browser.
3. Close the tab.
4. Open a new tab in your browser, and re-enter the camera’s IP address. The camera’s **Login** window opens.
5. Enter your login credentials. The camera’s home page opens.

9.3.1.2.5 OSD

The **OSD** (On-Screen Display) screen is used for setting the background color, text color, and location for displaying the date or text in two configurable locations on the **Live View** window. It is also possible to set the background color and text color to display upon the occurrence of an event.

Set the OSD location according to the following coordinates on the X and Y axes:

		1	2	3	4	5	6	7	8	9	10
Y-Axis	1	1x1	2x1	3x1	4x1	5x1	6x1	7x1	8x1	9x1	10x1
	2	1x2	2x2	3x2	4x2	5x2	6x2	7x2	8x2	9x2	10x2
	3	1x3	2x3	3x3	4x3	5x3	6x3	7x3	8x3	9x3	10x3
	4	1x4	2x4	3x4	4x4	5x4	6x4	7x4	8x4	9x4	10x4
	5	1x5	2x5	3x5	4x5	5x5	6x5	7x5	8x5	9x5	10x5
	6	1x6	2x6	3x6	4x6	5x6	6x6	7x6	8x6	9x6	10x6
	7	1x7	2x7	3x7	4x7	5x7	6x7	7x7	8x7	9x7	10x7
	8	1x8	2x8	3x8	4x8	5x8	6x8	7x8	8x8	9x8	10x8
	9	1x9	2x9	3x9	4x9	5x9	6x9	7x9	8x9	9x9	10x9
	10	1x10	2x10	3x10	4x10	5x10	6x10	7x10	8x10	9x10	10x10

X-Axis

OSD Location Coordinates

To configure OSD settings

1. Select **Basic Configuration > OSD**. The **OSD** screen is displayed.

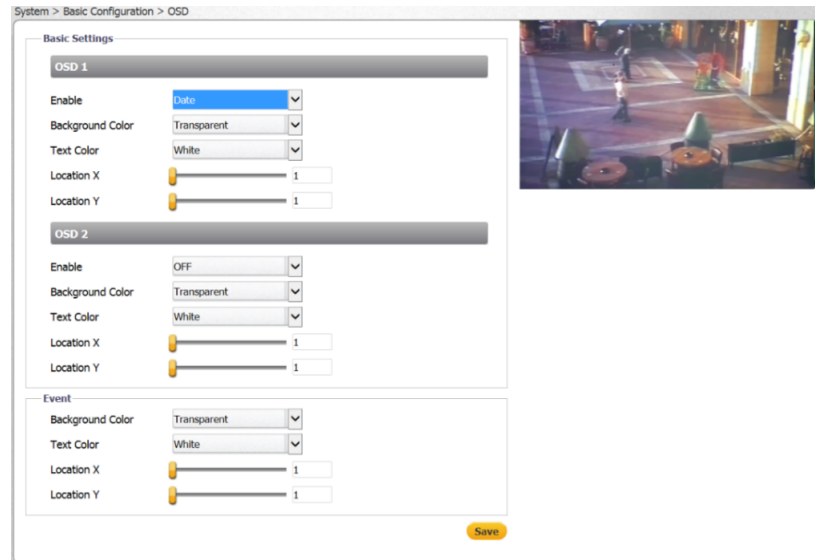

OSD Screen

2. In the *Basic Settings* section, configure the following settings for *OSD-1* and *OSD-2*:
 - *Enable* – From the drop-down list, select one of the following:
 - *Date* – Enables you to enter the date to display.
 - *Text* – Enables you to enter the time to display.
 - *OFF* – Disables the OSD function. This is the default setting.
 - *Background Color* – From the drop-down list, select *Black* or *Transparent* (default setting).
 - *Text Color* – From the drop-down list, select *Black* or *White* (default setting).
 - *Location X* – Move the slider from 1 to 10 to set the location on the screen for the OSD. The default setting is 1.
 - *Location Y* – Move the slider from 1 to 10 to set the location on the screen for the OSD. The default setting is 1.
3. In the *Event* section, configure the following settings in case an event occurs:
 - *Background Color* – From the drop-down list, select *Black* or *Transparent* (default setting).
 - *Text Color* – From the drop-down list, select *Black* or *White* (default setting).
 - *Location X* – Move the slider from 1 to 10 to set the location on the screen for the OSD. The default setting is 1.
 - *Location Y* – Move the slider from 1 to 10 to set the location on the screen for the OSD. The default setting is 1.
4. Click **Save** when finished.

9.3.1.3 User Accounts

The **User Accounts** screen is used for creating, modifying, and deleting accounts; creating or modifying credentials; and for assigning user access level (Administrator, Operator, and User). It is possible to create up to 10 users, in addition to the default Administrator, which cannot be deleted. There can be multiple users of all types.

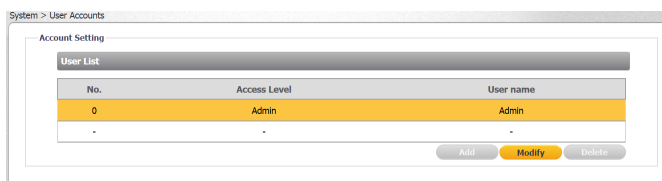

User Accounts-Account Setting Screen



Note:

1. User Name and Password can include up to 16 characters, including '0' to '9', 'a' to 'z', 'A' to 'Z', '!', '!', '+', '_' and '@'.
2. The user name and password are case-sensitive.

The following privileges are assigned to each access level:

- An *Administrator* has access to all screens. By default, the camera includes the *Administrator* access level. There can be more than one Administrator. The default Administrator cannot be deleted.
- An *Operator* has access to the **Live View** screen. An Operator can change the playback stream, take and store a snapshot, record live video and view it in full screen mode. There can be more than one Operator.
- A *User* can only view the **Live View** screen. A maximum of 9 Users is possible.

To modify default Administrator credentials

1. Click **Modify**. The **Access Level** dialog box opens.

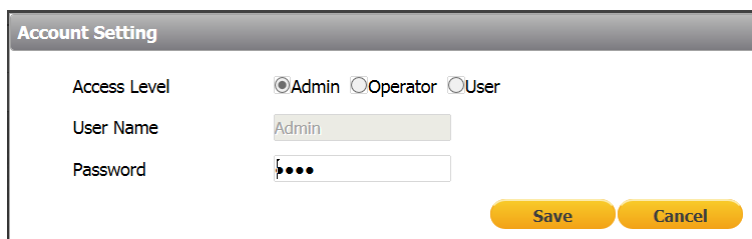

Default Administrator Access Level Dialog Box

2. For security reasons, enter a new User Name and /or Password. The default User Name is “Admin” and the default Password is “1234”. See the next section for conventions regarding the User Name and Password.
3. Click **Save**.

To add a new operator or user

- 1. Click the empty row.

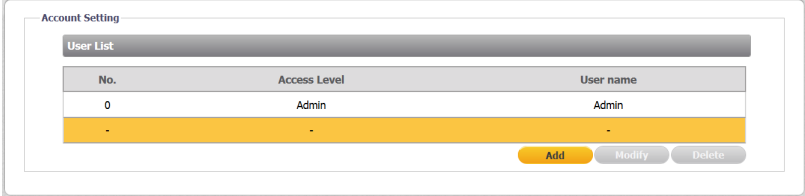

Add User Dialog Box

- 2. Click **Add**. The **Access Level** screen opens.

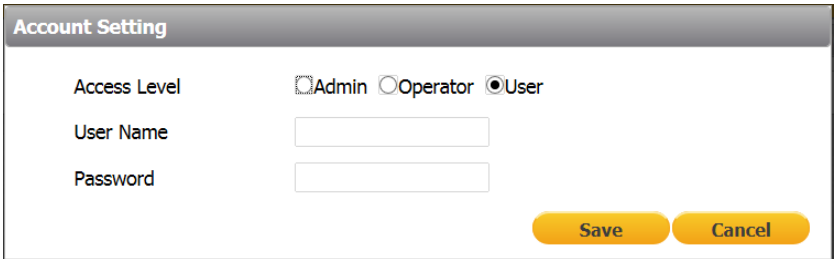

Empty Access Level Dialog Box

- 3. Select *Operator* or *User*, and enter the User Name and Password.

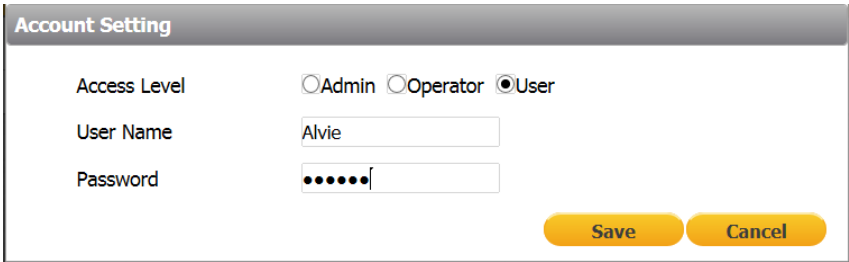

Filled Access Level Dialog Box

- 4. Click **Save**. The new Operator or User name is displayed in the *Account Setting* list.

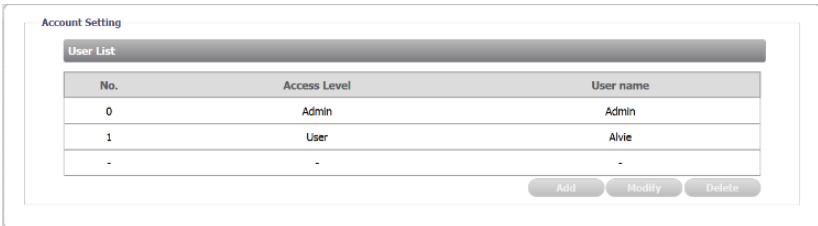

Updated Account Setting List

To modify an operator or user

- 1. Click **Modify**.
- 2. Enter the new User Name or Password.

To delete an operator or user

- 1. Click **Delete**. The operator or user is deleted from the Account Setting list.

9.3.1.4 Network

The **Network** tab includes the following screens:

[General](#) [FTP Server](#) [RTSP](#) [SNMP](#) [802.1X](#)
[IP Filter](#) [DDNS](#) [LDAP](#) [SSL](#)

9.3.1.4.1 General

The **General** screen is used for configuring most network settings.

Network > General Screen

To configure basic settings

1. In the *Basic Settings* section, do the following:
 - a. In the *Device Name* text box, enter a friendly name for the camera.
 - b. In the *HTTP Port* text box, enter the port number. The range is from 1025 to 65535. The default port is 80.
 - c. From the *Enable LDAP* drop-down list, select *ON* or *OFF*. If you select *ON*, verify that the information in **Network > LDAP** page is correct and that the LDAP server is online. The default is *OFF*.

2. Click **View** to view current network settings. The Internet Explorer **Basic Settings** dialog box opens, displaying network interface information, including Ethernet connection speed, Ethernet NIC MAC address, unit IP address, multicast address, and subnet mask. In the case of an IPv6 connection, the IPv6 address and IPv6 DNS address also are displayed.

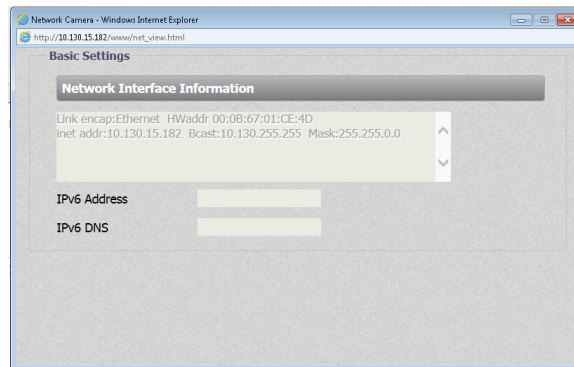

Internet Explorer Basic Settings Dialog Box

To configure IP settings

1. In the *IP Settings* section, configure the following settings
 - a. *Mode* – From the drop-down list, select one of the following:
 - *Manual* – Used for connecting to the network via a static IP address.
 - *PPPoE* – The camera can access the network via a DSL modem using the Point-to-Point Protocol over Ethernet (PPPoE). When connecting via a PPPoE connection, the *IP Address* field is disabled. After selecting this mode, enter the User Name and Password for the PPPoE account.
 - *DHCP* – Used for connecting to the network via a DHCP server. In DHCP mode, the *IPv4 Address*, *IPv4 Subnet Mask*, and *IPv4 Default Gateway* fields are disabled.
 - b. *IPv4 Address* – The IP address is necessary for network identification. Enter the IPv4 address if you are using IPv4 to connect to the network in Manual mode. In PPPoE and DHCP modes, the IPv4 address is assigned automatically.
 - c. *IPv4 Subnet Mask* – Used to determine if the destination is in the same subnet. The default value is 255.255.255.0. Enter the IPv4 subnet mask address if you are using IPv4 to connect to the network in Manual mode. In PPPoE and DHCP modes, the IPv4 subnet mask address is assigned automatically.
 - d. *IPv4 Default Gateway* – Used to forward frames to destinations in a different subnet. An invalid gateway setting causes transmission to destinations in other subnets to fail. Enter the IPv4 default gateway address if you are using IPv4 to connect to the network in Manual mode. In PPPoE and DHCP modes, the IPv4 default gateway address is assigned automatically.
 - e. *IPv6 Enable* – If you are using IPv6, select the checkbox to enable IPv6.
 - f. *Accept IPv6 Router Advertisement* – If you are using IPv6, select *ON*. The default is *OFF*.
 - g. *Enable DHCPv6* – If you are using IPv6, select *ON*. The default is *OFF*.
 - h. *IPv6 Address* – If you are using IPv6, enter the IPv6 address.
 - i. *Subnet Prefix Length* – If you are using IPv6, enter the subnet prefix length (1-128 digits).
 - j. *IPv6 Default Router Address* – If you are using IPv6, enter the IPv6 default router address.
 - k. *Subnet Prefix Length* – If you are using IPv6, enter the subnet prefix length (1-128 digits) for the IPv6 Default Router Address.
 - l. *IPv6 DNS* – If you are using IPv6, enter the IPv6 DNS address.

To configure the Wire Setting

- In the *Wire Setting* section, from the *Speed & Duplex* drop-down list, select one of the following:
 - 10 Mbps Half Duplex
 - 10 Mbps Full Duplex
 - 100 Mbps Half Duplex
 - 100 Mbps Full Duplex
 - Auto (default setting)

To enable UPnP settings

- In the *UPnP* section, from the *Enable UPnP* drop-down list, select *ON*. The default is *ON*. This enables the camera to be detected by any unit on the LAN.
- From the *Mode* drop-down list, select one of the following:
 - IP and Device Name* – The camera connects to the UPnP server by using its IP address and default device name. This is the default setting.
 - Device Name* – The camera connects to the UPnP server by using the default camera name.
 - User Input* – The camera connects to the UPnP server by using a friendly name. Enter the name in the *Friendly Name* text box that opens when this option is selected:

UPnP	
Enable UPnP	ON
Mode	User Input
Friendly Name	reception desk

UPnP User Input Screen

To enable SSL

- In the *SSL* section, from the *Enable SSL* drop-down list, select *ON*. The default is *OFF*.



Note:
You must install or generate an SSL certificate before enabling SSL.

9.3.1.4.2 FTP Server

The camera includes a built-in FTP server which enables remote access to files of events that are captured in snapshots or recorded on clips and are stored on the camera's microSD card. The **FTP Server** screen is used to enable remote access of the camera's microSD card. No configuration of the camera's internal FTP server is required by the user. The camera's IP address is ftp://<camera IP address>.

To access the FTP server

1. From the *Enable* drop-down list, select *ON*. The default is *OFF*.



Network > FTP Screen

2. Click **Save**.

Note:

Even when set to *Off*, recordings and snapshots will still be stored in the camera's microSD card. However, the user will not be able to remotely access them via FTP.

9.3.1.4.3 RTSP

The **RTSP** screen is used for transmitting the encoded video stream. The RTSP protocol is used for establishing the connection and controlling the streaming data between the camera and a device over the web. Each stream can be sent by unicast to one device or broadcasted by multicast to multiple devices. Unicast requires larger network bandwidth and more server resources, but is more stable than multicast, which requires more settings.

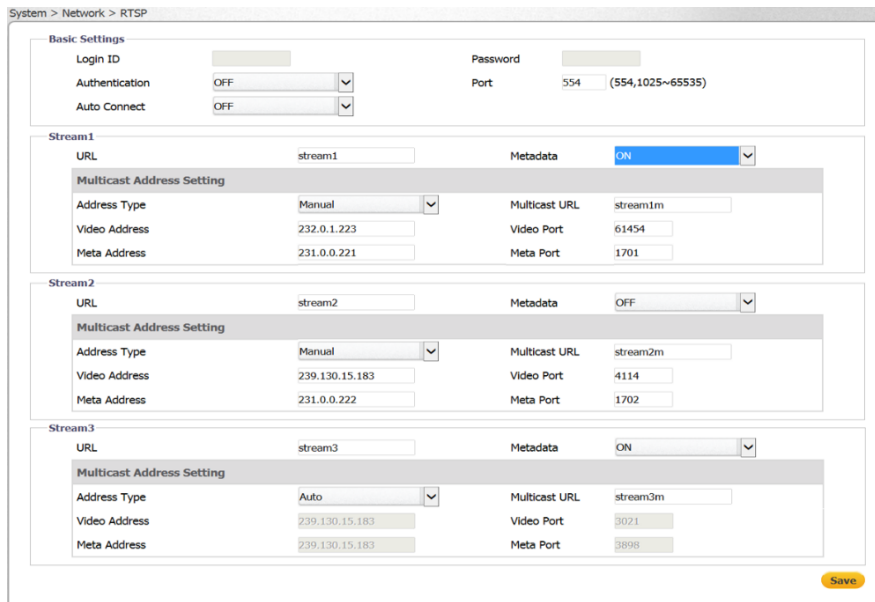

Network > RTSP Screen

To configure basic settings

1. In the *Login ID* text box, enter your Login ID number.



Note:

It is recommended, but not necessary, to enable authentication in order to use RTSP.

2. From the Authentication drop-down list, select *ON* to encrypt the transmission. The default is *OFF*.
3. In the *Password* text box, enter your password after selecting Authentication *ON*.
4. In the *Port* text box, enter the RTSP network port. The default is *554*. The range is *1025* to *65535*.
5. From the *Auto Connect* drop-down list, select *ON* or *OFF*. The default is *OFF*.

To configure the multicast address

1. In the *Stream1* section, in the URL text box, enter the RTSP server's URL. The default is *stream1*.
2. From the *Metadata* drop-down list, select *ON* or *OFF*. The default is *OFF*.
3. From the *Address Type* drop-down list, select *Manual* or *Auto*. The default is *Auto*.
4. In the *Multicast URL* text box, enter the multicast URL. The default is *stream1m*. Valid multicast addresses are in the range *224.0.1.1* – *239.255.255.254*.



Note:

Switches, routers and devices must be configured to support multicast if this mode is selected.

5. In the *Video Address* text box, enter the IP address for the RTSP server.
6. In the *Video Port* text box, enter the network port number for communicating with the RTSP server.
7. In the *Meta Address* text box, enter the IP address to which the metadata is sent.
8. In the *Meta Port* text box, enter the network port number for transmitting the metadata.
9. If you are using the second or third stream, in the *Stream2* or *Stream3* section, repeat the above steps.
10. Click **Save**.

9.3.1.4.4 SNMP

The **SNMP** screen enables the network management system to use the Simple Network Management Protocol (SNMP) to remotely monitor and manage the camera. Select one of the following SNMP versions: SNMP v1, SNMP v2c, or SNMP v3.

Network > SNMP Screen

To use SNMP v1

1. From the *SNMP v1* section's *Enable* drop-down list, select *ON*. The default is *OFF*.
2. Click **Save**.

To use SNMP v2c

1. From the *SNMP v2c* section's *Enable* drop-down list, select *ON*. The default is *OFF*.
2. In the *Read Community String* text box, enter the community name that has read-only access to all supported SNMP objects. The default value is *public*.
3. In the *Write Community String* text box, enter the community name that has read/write access to all supported SNMP objects (except read-only objects). The default value is *private*.
4. In the *Trap Community String* text box, enter the community to use when sending a trap message to the management system. The default value is *public*. Traps are used by the camera to send messages to the management system for important events or status changes.
5. Click **Save**.

To use SNMP v3

1. From the *SNMP v3* section's *Enable* drop-down list, select *ON*. The default is *OFF*.
2. From the *Authentication Mode* drop-down list, select *MD5*, *SHA*, or *NONE* (default).
3. If you select *MD5* or *SHA*, from the *Privacy Mode* drop-down list, select *AES*, *DES*, or *NONE* (default).
4. Enter the User Name. The default is *initial*.
5. If you select *MD5* or *SHA*, enter the Authentication Password in the *Authentication Password* text box.
6. The *Privacy Password* text box is disabled.
7. Click **Save**.

To use traps

1. In the *Trap* section, from the *Mode* drop-down list, select *V1*, *V2C*, *V3*, or *OFF*, according to the SNMP version that you select above. The default is *OFF*.
2. From the *Heartbeat* drop-down list, select *ON* or *OFF*. The default is *OFF*. When selected, this enables you to ping the VMS.
3. From the *Event* drop-down list, select *ON* to notify the VMS in case of an event. The default is *OFF*.
4. In the *Target IP* text box, enter the IP address of the Trap Host.
5. In the *Heartbeat Interval* text box, enter the interval of time in seconds for the camera to ping the VMS, for example, every 10 seconds. The range is 5-600. The default is 30.
6. Click **Save**.

To download the SNMP MIB

1. In the *Download MIB* section, click **Download**. The database used for managing the entities in the communications network is downloaded.

9.3.1.4.5 802.1X

The **802.1X** screen is used for enabling the camera to access a network protected by the 802.1X/EAPO (Extensible Authentication Protocol over LAN) authentication protocol. Before using this function, you must register a user name and password for the 802.1X server and configure the authentication server. Contact the network administrator to obtain certificates, user IDs, and passwords.

To enable 802.1X

1. From the *Protocol* drop-down list, select one of the following: *EAP-MD5*, *EAP-TTLS*, *MD5-PEAP*, or *NONE*. The default is *NONE*.



Network > 802.1X Screen

2. Click **Save**. The **Basic Settings** screen for the selected protocol opens.

To enable EAP-MD5

1. Select *EAP-MD5*. The **Basic Settings** screen opens.

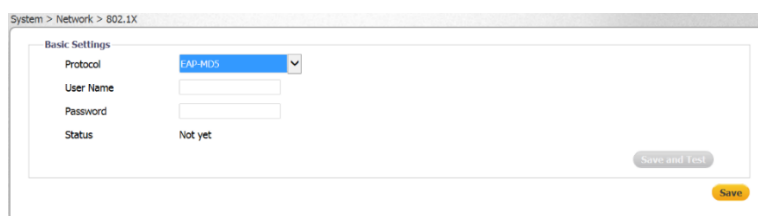

EAP-MD5 Screen

2. Enter the User Name and Password in the respective text box.
3. Do one of the following:
 - Click **Save**. The status is displayed as “Not yet” until the configuration is saved.
 - Click **Test and Save** to test and save the configuration.

To enable EAP-TTLS

1. Select *EAP-TTLS*. The **Basic Settings** screen opens.

The screenshot shows a web interface titled 'System > Network > 802.1X'. Under 'Basic Settings', the 'Protocol' dropdown is set to 'EAP-TTLS' and 'Inner Authentication' is set to 'CHAP'. There are three empty text input fields for 'User Name', 'Password', and 'Anonymous ID'. Below these, the 'Status' is 'Not Installed' and there is a yellow 'Browse' button next to 'CA Certificate'. At the bottom right, there are 'Save and Test' and 'Save' buttons.

EAP-TTLS Screen

2. From the *Inner Authentication* drop-down list, select one of the following protocols: *CHAP*, *EAP-MSCHAPV2*, *MD5*, *MSCHAP*, *MSCHAPV2*, or *PAP*.
3. Enter the User Name and Password in the respective text box.
4. Enter the Anonymous ID in the *Anonymous ID* text box.
5. Click **Browse** to download the CA Certificate. The Status is displayed as “Not Installed” until the CA certificate is downloaded.
6. Do one of the following:
 - Click **Save**. The status is displayed as “Not Installed” until the configuration is saved.
 - Click **Test and Save** to test and save the configuration.

To enable EAP-PEAP

1. Select *EAP-PEAP*. The **Basic Settings** screen opens. By default the Inner Authentication protocol is MSCHAPV2.

The screenshot shows a web interface titled 'System > Network > 802.1X'. Under 'Basic Settings', the 'Protocol' dropdown is set to 'EAP-PEAP' and 'Inner Authentication' is set to 'mschapv2'. There are two empty text input fields for 'User Name' and 'Password'. Below these, the 'Status' is 'Not Installed' and there is a yellow 'Browse' button next to 'CA Certificate'. At the bottom right, there are 'Save and Test' and 'Save' buttons.

EAP-PEAP Screen

2. Enter the User Name and Password in the respective text box.
3. Click **Browse** to download the CA Certificate.
4. Do one of the following:
 - Click **Save**. The status is displayed as “Not Installed” until the configuration is saved.
 - Click **Test and Save** to test and save the configuration.

9.3.1.4.6 IP Filter

The **IP Filter** screen is used for restricting access to the camera by allowing or denying specific IP addresses. It is possible to filter up to 10 IP addresses. The options are *Allow*, *Deny*, or *NONE* (default).

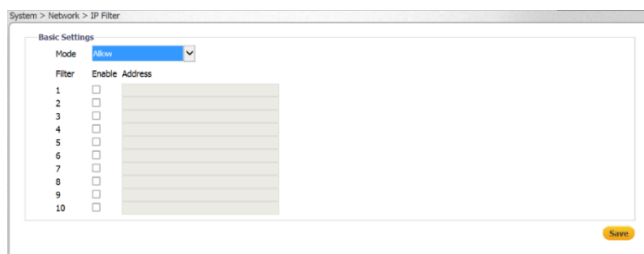

Network > IP Filter Screen

To allow an IP address

1. From the *Filter* drop-down list, select *Allow*.
2. Check the *Enable* checkbox for each IP address for which you want to allow access.
3. Enter the IP address in the *Address* text box.
4. Click **Save**.

To deny an IP address

1. From the *Filter* drop-down list, select *Deny*.
2. Check the *Enable* checkbox for each IP address for which you want to deny access.
3. Enter the IP address in the *Address* text box.
4. Click **Save**.

9.3.1.4.7 DDNS

The DDNS (Dynamic DNS) screen is used for network access if you select PPPoE as the default network connection. Before configuring the system to use DDNS, you must first register with a DDNS service provider.

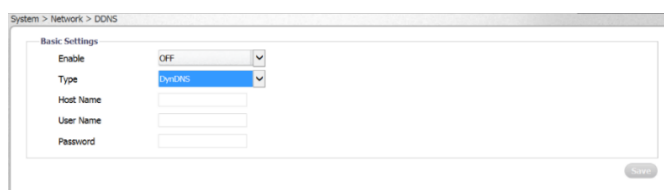

Network > DDNS Screen

To use DDNS

1. From the *Enable* drop-down list, select ON. The default is *OFF*.
2. From the *Type* drop-down list, select the DDNS service provider:
 - DynDNS: custom@dyndns.org (default)
 - No-IP: default@no-ip.com
 - Two-DNS: default@two-dns.de
 - FreeDNS: default@freedns.afraid.org
3. Enter the Host Name, User Name, and Password in the respective text box.

4. If you are using FreeDNS, the *Hash* text box also is displayed. Enter the Hash value, which is a hash of your user name and password. It is available from <http://freedns.afraid.org>.
5. Click **Save**.

9.3.1.4.8 LDAP

The **LDAP** screen is used for configuring use of the Lightweight Directory Access Protocol, an industry-standard protocol for accessing and maintaining distributed directory information services over an IP network.

System > Network > LDAP

Basic Settings

Server

Port (389, 1025~65535)

Base DN

Bind DN Template

Search Template

Group Mappings

Admins

Operators

Users

Authentication

User Name

Password

Save

Network > LDAP Screen

To configure LDAP basic settings

1. In the *Server* text box, enter the LDAP server address.
2. In the *Port* text box, enter the network port number of the LDAP server. The range is 1025 to 65535. The default is 389.
3. In the *Base DN* text box, enter or edit the default Distinguished Name (Domain Components) of the parent entry. This is used for searching the directory tree in the LDAP server. The default setting is *dc=ipcamera,dc=com*.
4. In the *Bind DN Template* text box, enter or edit the attributes used for authenticating the camera on the LDAP server. The default setting is *uid=%u,dc=users,dc=ipcamera,dc=com*.
5. In the *Search Template* text box, enter or edit the attribute used for the Common Name. The default is *cn=%u*.

To configure group mappings

1. In the *Admins* text box, enter or edit the attributes used for searching for an Administrator.
2. In the *Operators* text box, enter or edit the attributes used for searching for an Operator.
3. In the *Users* text box, enter or edit the attributes used for searching for a User.

To configure authentication settings

1. Enter the User Name and Password in the respective text boxes to access the LDAP server.
2. Click **Save**.

9.3.1.4.9 SSL

The **SSL** screen is used for configuring the Secure Socket Layer (SSL) or Transport Layer Security (TLS) protocol, which protects camera settings and username/password information. SSL/TLS is used, in turn, by the HTTPS protocol for allowing secure IP connections between the camera and a web browser over HTTP.



Note:
SSL is enabled from the [Network > General](#) screen.

In order to use HTTPS on the camera, an HTTPS certificate must be installed. The HTTPS certificate can be obtained either by creating and sending a certificate request to a Certificate Authority (CA) or by creating a self-signed HTTPS certificate as described below.



Note:
The self-signed certificate does not provide the same level of security as a CA-issued certificate.

To configure SSL settings

- From the *Method* drop-down list, select one of the following: *Self-Signed*, *Request*, or *Upload Certificate*. The default is *NONE*.



System > Network > SSL

Generate Certificate

Method: NONE

Network > SSL Screen

To obtain a self-signed certificate

- From the *Method* drop-down list, select *Self-Signed*. The **Self-Signed** screen is displayed.

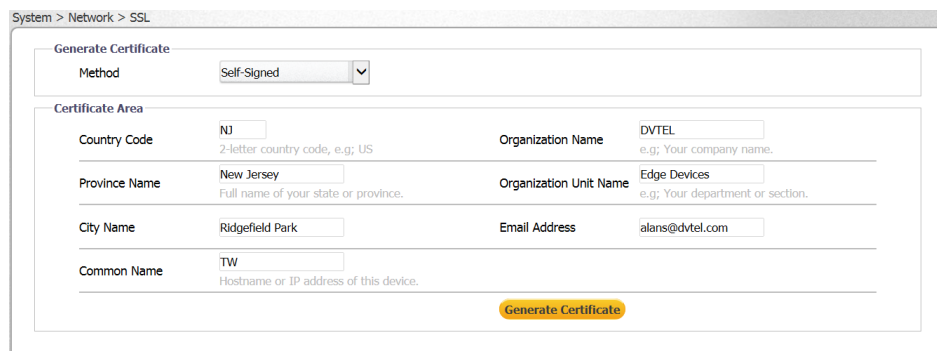

System > Network > SSL

Generate Certificate

Method: Self-Signed

Certificate Area

Country Code	<input type="text" value="NJ"/>	Organization Name	<input type="text" value="DVTEL"/>
	<small>2-letter country code, e.g; US</small>		<small>e.g; Your company name.</small>
Province Name	<input type="text" value="New Jersey"/>	Organization Unit Name	<input type="text" value="Edge Devices"/>
	<small>Full name of your state or province.</small>		<small>e.g; Your department or section.</small>
City Name	<input type="text" value="Ridgefield Park"/>	Email Address	<input type="text" value="alans@dvitel.com"/>
Common Name	<input type="text" value="TW"/>		
	<small>Hostname or IP address of this device.</small>		

Generate Certificate

SSL Self-Signed Screen

2. Enter the following information in the appropriate field. A definition of each of the required fields follows.
 - *Country Code* – Enter a two-letter combination code to indicate the specific country in which the certificate will be used. For instance, type “US” to indicate United States.
 - *Province Name* – Enter the local administrative region.
 - *City Name* – Enter other geographical information.
 - *Common Name* – Indicate the name of the person or other entity that the certificate identifies (often used to identify the website).
 - *Organization Name* – Enter the name of the organization to which the entity identified in *Common Name* belongs.
 - *Organization Unit Name* – Enter the name of the organizational unit to which the entity identified in the *Common Name* field belongs.
 - *Email Address* – Enter the email address of the person responsible for maintaining the certificate.
3. Click **Generate Certificate** to save the certificate request after completion. The details are displayed in the Certificate Information section that opens on the **SSL** screen.

Certificate Information			
Common Name	TW		
Organization	DVTEL	Country	NJ
Locality	Ridgefield Park, New Jersey	Issuer	DVTEL
Valid from	Mar 18 07:34:05 2014 GMT	To	Mar 18 07:34:05 2015 GMT

[Delete Certificate](#)

SSL Certificate Information Section

4. To delete the certificate, click **Delete Certificate**. The certificate is deleted.

To request a certificate

1. From the *Method* drop-down list, select *Request*. The **Request** screen is displayed.

System > Network > SSL

Generate Certificate

Method:

Certificate Area

Country Code: <input type="text" value="NJ"/> <small>2-letter country code, e.g; US</small>	Organization Name: <input type="text" value="DVTEL"/> <small>e.g; Your company name.</small>
Province Name: <input type="text" value="New Jersey"/> <small>Full name of your state or province.</small>	Organization Unit Name: <input type="text" value="Edge Devices"/> <small>e.g; Your department or section.</small>
City Name: <input type="text" value="Ridgefield Park"/>	Email Address: <input type="text" value="alans@dvstel.com"/>
Common Name: <input type="text" value="TW"/> <small>Hostname or IP address of this device.</small>	

[Generate Certificate](#)

SSL Request Screen

2. Follow steps 2-4 above to obtain a self-signed certificate.

To upload a certificate

1. From the *Method* drop-down list, select *Upload Certificate*. The **Upload Certificate** screen is displayed.

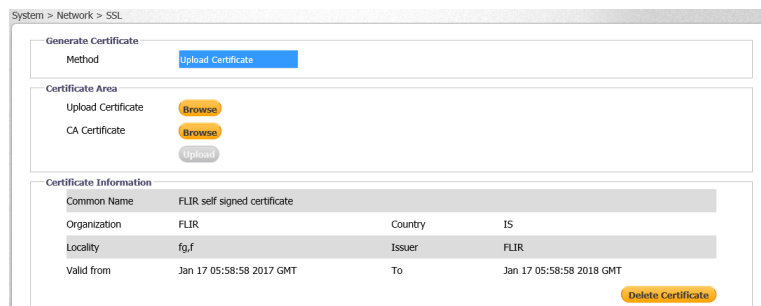

Upload Certificate Screen

2. Do one of the following:
 - To locate and upload a self-signed certificate, click **Upload Certificate > Browse**.
 - To locate and upload a Certificate Authority (CA) certificate, click **CA Certificate > Browse**.
3. Click **Upload**. The certificate is uploaded.

9.3.1.5 Events Source

The **Events Source** tab is used for configuring general settings related to event notification. It includes the following screens:

[Alarm](#) [Audio](#) [Motion](#) [Network](#) [Schedule](#) [Tampering](#)

9.3.1.5.1 Alarm

The **Events Source > Alarm** screen is used for enabling an alarm when an event occurs and for defining actions when an alarm occurs. Actions include:

- Sending an alarm
- Defining the method for storing a snapshot in the camera's microSD card
- Sending a snapshot of the event to an FTP server
- Recording an event in the camera's microSD card
- Sending email notifications
- Displaying text on-screen if the network connection is there is an alarm
- Setting the arming schedule

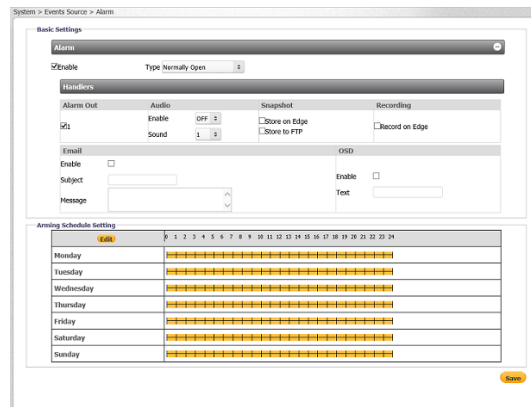

Events Source > Alarm Screen

To enable an alarm

1. Select the *Enable* checkbox.
2. Click **Save**.

To select the type of alarm

1. From the *Type* drop-down list, select *Normally Open* or *Normally Closed*.
2. Click **Save**.

To enable the Alarm Out function

1. In the *Handlers* section, select the *Alarm Out* checkbox. By default, it is not checked.
2. Click **Save**.

To enable audio

1. In the *Handlers* section, from the *Audio Enable* drop-down list, select *ON*. By default, it is not checked.
2. From the *Audio Sound* drop-down list, select the number for the audio file that you want to play. See the [Event Handler > Sound](#) section to load the audio files that are triggered upon occurrence of an event.
3. Click **Save**.

To define the method to store a snapshot

1. In the *Snapshot* section, select the *Store on Edge* checkbox to store a snapshot on the camera's microSD card. By default, it is not checked.
2. In the *Snapshot* section, select the *Store to FTP* checkbox to store a snapshot on a remote FTP site. By default, it is not checked.

To record an event

1. In the *Recording* section, select the *Record on Edge* checkbox to record a clip on the camera's microSD card. By default, it is not checked.
2. Click **Save**.

To send email notifications

1. In the *Email* section, select the *Enable* checkbox. By default, *Enable* is not checked.
2. In the *Subject* text box, enter the email subject text.
3. In the *Message* text box, enter the email message text.

4. Click **Save**.

To activate the on-screen display

1. In the *OSD* section, select *Enable*. By default, *Enable* is not checked.
2. In the *Text* text box, enter the text to display in the on-screen display.
3. Click **Save**.

To set the arming schedule

1. In the *Arming Schedule Setting* area, click **Edit**. The **Edit** screen opens.

	Start Time	End Time	Action
Monday			
	02:00	10:00	<input checked="" type="checkbox"/>
	12:00	15:30	<input checked="" type="checkbox"/>
	19:00	23:00	<input checked="" type="checkbox"/>
Tuesday			
	00:00	23:59	<input type="checkbox"/>
	00:00	23:59	<input type="checkbox"/>
	00:00	23:59	<input type="checkbox"/>
Wednesday			
	00:00	23:59	<input type="checkbox"/>
	00:00	23:59	<input type="checkbox"/>
	00:00	23:59	<input type="checkbox"/>
Thursday			
	00:00	23:59	<input type="checkbox"/>
	00:00	23:59	<input type="checkbox"/>
	00:00	23:59	<input type="checkbox"/>
Friday			
	00:00	23:59	<input type="checkbox"/>
	00:00	23:59	<input type="checkbox"/>
	00:00	23:59	<input type="checkbox"/>
Saturday			
	00:00	23:59	<input type="checkbox"/>
	00:00	23:59	<input type="checkbox"/>
	00:00	23:59	<input type="checkbox"/>
Sunday			
	00:00	23:59	<input type="checkbox"/>
	00:00	23:59	<input type="checkbox"/>
	00:00	23:59	<input type="checkbox"/>
<input type="checkbox"/> Select/Deselect All			<input type="button" value="Apply"/> <input type="button" value="Cancel"/>

2. In the *Start Time* column, enter the time(s) and day(s) you want to trigger an action.
3. In the *End Time* column, enter the time(s) and day(s) you want to stop the action.
4. Select the *Action* checkbox if you want to enable the action at these times.
5. Select the *Select/Deselect All* checkbox as required.
6. Click **Apply**. The times for the schedule are displayed in orange in the *Arming Schedule Setting* section of the **Defocus** screen.

Arming Schedule Setting

	0	1	2	3	4	5	6	7	8	9	10	11	12	13	14	15	16	17	18	19	20	21	22	23	24
Monday																									
Tuesday																									
Wednesday																									
Thursday																									
Friday																									
Saturday																									
Sunday																									

Updated Arming Schedule Setting Section

9.3.1.5.2 Audio

The **Events Source > Audio** screen is used for setting the audio threshold level of the audio input. An audio event is created when the Sound Intensity Threshold is exceeded. Actions include:

- Setting the audio threshold level, which creates an audio event when the Sound Intensity Threshold is exceeded
- Sending an alarm
- Defining the method for storing a snapshot in the camera's microSD card
- Sending a snapshot of the event to an FTP server
- Recording an event in the camera's microSD card
- Sending email notifications
- Displaying text on-screen if there is an audio event
- Setting the arming schedule

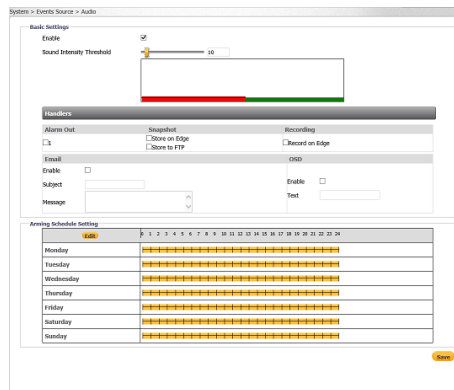

Events Source > Audio Screen



Note:

In order to use this function, audio must be enabled from the [System > Basic Configuration > Audio](#) screen.

A graph displays audio when is detected. Audio that is below the Sound Intensity Threshold is displayed in green. When audio exceeds the defined threshold, it creates an audio event and is displayed in red.

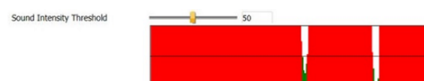

Sound Intensity Threshold

Setting a low threshold (for example, 25) means that the camera is more sensitive to noise, which results in more alerts (displayed in red). The setting depends on the situation and environment. If the scene is located in a quiet place, it is possible to use lower threshold. A noisy location requires a higher threshold.

When selecting *Record to Edge*, the recording includes the audio track. *OSD* must be enabled on the **Events Source > Audio** screen, as well as from the [System > Basic Configuration > OSD](#) screen, in order to insert on-screen displays on clips and snapshots.



Note:

Recording must be enabled from the [System > Events Handler > Recording Settings](#) screen in order to record audio.

To enable audio

1. Select the *Audio* checkbox.
2. Click **Save**.

To set the audio level

1. Move the *Sound Intensity Threshold* slider to the desired level between 1-100. The lower the setting, more sounds that are detected.
2. Click **Save**.

To define the method to store a snapshot

1. See instructions in the [Alarm](#) section.

To record an event

1. See instructions in the [Alarm](#) section.

To send email notifications

1. See instructions in the [Alarm](#) section.

To activate the on-screen display

1. See instructions in the [Alarm](#) section.

To set the arming schedule

1. See instructions in the [Alarm](#) section.

9.3.1.5.3 Motion

The **Events Source > Motion** screen is used for:

- Enabling and defining the motion zone area settings
- Sending an alarm upon a motion event
- Selecting and playing an audio file upon a motion event
- Defining the method for storing a snapshot in the camera's microSD card
- Sending a snapshot of the event to an FTP server
- Recording an event in the camera's microSD card
- Sending email notifications
- Displaying text on-screen upon a motion event
- Setting the arming schedule

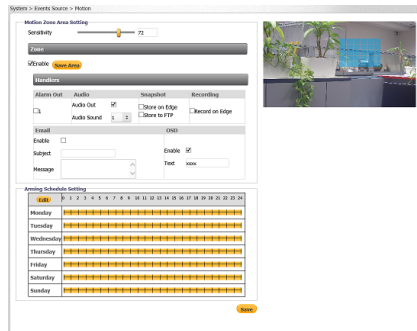

Events Source > Motion Screen

**Note:**

If the camera is attached to Latitude, motion detection configuration should be done from Latitude Admin Center, not from the web interface.

To configure motion zone area settings

1. From the *Sensitivity* drop-down list, select *High*, *Medium*, or *Low*. The camera reacts to slight changes in motion or brightness in the motion zone when set to *High*, while the camera reacts to big changes in brightness or motion when set to *Low*.

To enable motion settings

1. In the *Zone* section, click *Enable*. By default, *Enable* is not checked.
2. Set the motion detection area by left-clicking the screen and dragging the cursor over the area. Right-click the detection area to delete the area.
3. Click **Save Area**.

To enable the Alarm Out function

1. See instructions in the [Alarm](#) section.

To enable the Audio Out function

1. In the *Handlers* section, select the *Audio Out* checkbox. By default, it is not checked.
2. From the *Audio Sound* drop-down list, select the number for the audio file that you want to play. See the [Event Handler > Sound](#) section to load the audio files that are triggered upon occurrence of an event.
3. Click **Save**.

To define the method to store a snapshot

1. See instructions in the [Alarm](#) section.

To record an event

1. See instructions in the [Alarm](#) section.

To send email notifications

1. See instructions in the [Alarm](#) section.

To activate the on-screen display

1. See instructions in the [Alarm](#) section.

To set the arming schedule

1. See instructions in the [Alarm](#) section.

9.3.1.5.4 Network

The **Events Source > Network** screen is used for enabling notification in case the network connection is lost or if there is another device on the network that is using the same IP address as the camera. This screen enables you to:

- Send an alarm
- Select and play an audio file upon the occurrence of an event
- Record an event in the camera's microSD card
- Display text on-screen if the network connection is lost or if there is a network conflict

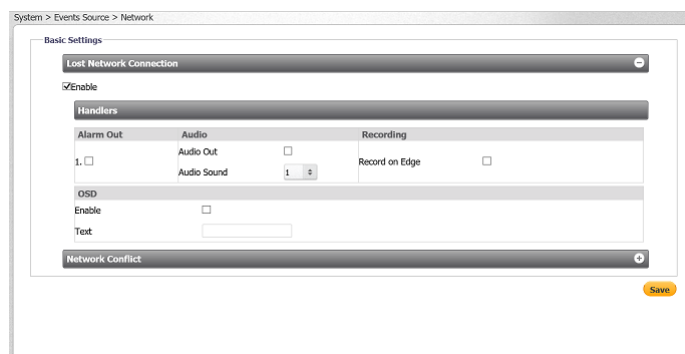

Events Source > Network Screen

To enable notifications

1. Select *Enable*. By default, *Enable* is not checked.
2. Click **Save**.

To enable the Alarm Out function

1. See instructions in the [Alarm](#) section.

To enable the Audio Out function

1. In the *Handlers* section, select the *Audio Out* checkbox. By default, it is not checked.
2. From the *Audio Sound* drop-down list, select the number for the audio file that you want to play. See the [Event Handler > Sound](#) section to load the audio files that are triggered upon occurrence of an event.
3. Click **Save**.

To record an event

1. See instructions in the [Alarm](#) section.

To activate the on-screen display

1. See instructions in the [Alarm](#) section.

9.3.1.5.5 Schedule

The **Events Source > Schedule** screen is used for:

- Setting a trigger interval for notifications
- Sending an alarm
- Selecting and playing an audio file upon the occurrence of an event
- Defining the method for storing a snapshot in the camera's microSD card
- Sending a snapshot of the event to an FTP server
- Recording an event in the camera's microSD card
- Sending email notifications
- Setting the alarm schedule

Events Source > Schedule Screen

To set a trigger interval

1. Select *Enable*. By default, *Enable* is not checked.
2. Move the *Trigger Interval* slider from 1 to 3600 seconds. The default setting is 10 seconds.

To enable the Alarm Out function

1. See instructions in the [Alarm](#) section.

To enable the Audio Out function

1. In the *Handlers* section, select the *Audio Out* checkbox. By default, it is not checked.
2. From the *Audio Sound* drop-down list, select the number for the audio file that you want to play. See the [Event Handler > Sound](#) section to load the audio files that are triggered upon occurrence of an event.
3. Click **Save**.

To define the method to store a snapshot

1. See instructions in the [Alarm](#) section.

To record an event

1. See instructions in the [Alarm](#) section.

To send email notifications

1. See instructions in the [Alarm](#) section.

To set the arming schedule

1. See instructions in the [Alarm](#) section.

9.3.1.5.6 Tampering

The **Events Source > Tampering** screen enables you to:

- Enable and define tampering settings
- Send an alarm upon a tampering event
- Select and play an audio file upon a tampering event
- Define the method for storing a snapshot in the camera’s microSD card
- Send a snapshot of the event to an FTP server
- Record an event in the camera’s microSD card
- Send email notifications
- Display text on-screen if there is a tampering event
- Set the alarm schedule

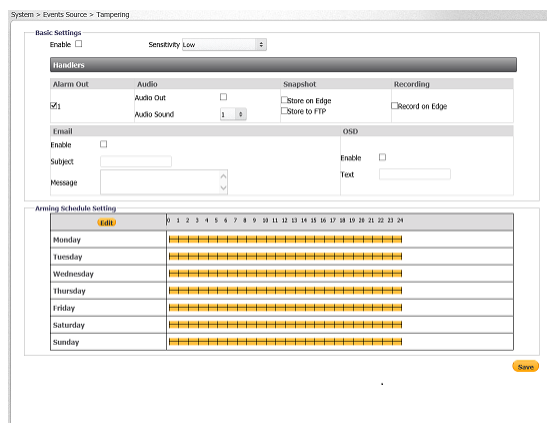

Events Source > Tampering Screen

To enable tamper detection

1. Select *Enable*. By default, *Enable* is not checked.
2. From the *Sensitivity* drop-down list, select *High*, *Medium*, or *Low*.

To enable the Alarm Out function

1. See instructions in the [Alarm](#) section.

To enable the Audio Out function

1. In the *Handlers* section, select the *Audio Out* checkbox. By default, it is not checked.
2. From the *Audio Sound* drop-down list, select the number for the audio file that you want to play. See the [Event Handler > Sound](#) section to load the audio files that are triggered upon occurrence of an event.
3. Click **Save**.

To define the method to store a snapshot

1. See instructions in the [Alarm](#) section.

To record an event

1. See instructions in the [Alarm](#) section.

To send email notifications

1. See instructions in the [Alarm](#) section.

To activate the on-screen display

1. See instructions in the [Alarm](#) section.

To set the arming schedule

1. See instructions in the [Alarm](#) section.

9.3.1.6 Events Handler

The **Events Handler** tab is used for configuring settings for the various methods used for event notification. The tab includes the following screens:

[Email](#) [Alarm Out](#) [FTP](#) [Recording Settings](#) [SD Card](#) [Snapshot](#) [Sound](#)

9.3.1.6.1 Email

It is possible to send notifications to up to 10 email addresses.

Note:

Before configuring email settings, check that:

- There is an SMTP mail server on the local area network (LAN).
- The network is connected to either an intranet or the Internet.
- TCP/IP settings, including DNS Server settings, are configured in the [Network > General](#) screen.

To configure email settings

1. Select the **Email** tab. The **Email** screen is displayed.

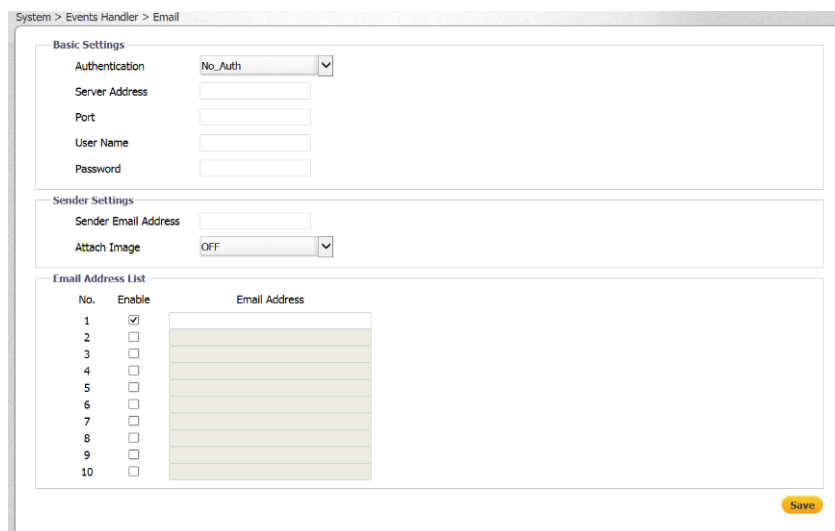

Events Handler > Email Screen

2. In the *Basic Settings* area, configure the following settings:
 - a. *Authentication* – From the drop-down list, select one of the following authentication methods:
 - *No_Auth* – No email authentication method is used. This is the default setting.
 - *SMTP Plain* – PLAIN is the least secure of all the SASL (Simple Authentication and Security Layer) authentication mechanisms because the password is sent unencrypted across the network. The PLAIN authentication mechanism is described in RFC 2595.
 - *Login* – The Login mechanism is supported by Microsoft's Outlook Express and by some other clients.
 - *TLS-TTLS* – The Tunneled Transport Layer Security is used to tunnel an entire network stack to create a VPN.
 - b. *Server Address* – In the text box, enter the email server IP address.
 - c. *Port* – In the text box, enter the email server port number. The default port is 25.
 - d. *User Name* – In the text box, enter the email server user name.
 - e. *Password* – In the text box, enter the email server password.
3. In the *Sender Settings* area, configure the following settings:
 - a. *Sender Email Address* – In the text box, enter the sender's email address.
 - b. *Attach Image* – From the drop-down list, select *ON* or *OFF* (default setting).
4. In the *Email Address List* section, do the following for each email address:
 - a. Select the checkbox in the *Enable* column. By default, *Enable* is not checked.
 - b. Enter the email address in the *Email Address* column.
 - c. Click **Save**.

9.3.1.6.2 Alarm Out

The **Alarm Out** screen is used for configuring settings for the camera's single alarm output.

There are two methods for enabling Alarm Out:

- *Pulse* – When this is selected, the user can select the Type *Normally Open* or *Normally Closed*.
 - When *Normally Open* is selected, new text boxes are displayed in which the user can specify the following:
 - *On Time* – amount of time (in seconds) that the alarm is ON
 - *Off Time* – amount of time (in seconds) between ON states
 - *Count* – the number of frames for the post-trigger buffer

System > Events Handler > Alarm Out

Alarm Out 1

Enable	ON
Method	Pulse
Type	Normally Open
On Time	<input type="text"/> (0.1~200 sec)
Off Time	<input type="text"/> (0.1~200 sec)
Count	<input type="text"/> (1~9999 Frame)

Save

- When *Normally Closed* is selected, these text boxes are not displayed, the alarm output is activated for the specified duration (*On Time*) during which the output opens. The same settings are displayed as on the *Normally Open* setting.

- *Normal* – When this is selected, a new field (*Post Duration*) is displayed. The Post Duration time determines the length of time that the alarm is triggered. It can be set to Infinite (the alarm is active until deactivated) or set to 5, 10, 15, or 30 seconds.



9.3.1.6.3 FTP

The **FTP** screen is used for configuring the settings of an FTP server located remotely on the network. The server is used for saving snapshots of events that are configured from the [Events Source](#) section and transmitted from the camera via FTP to the remote FTP server.

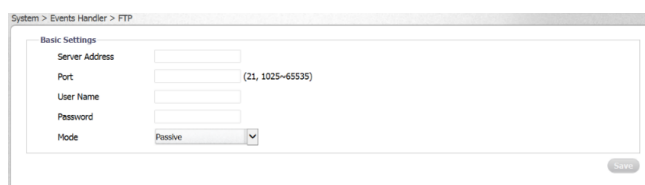

Events Handler > FTP Screen

To configure FTP server settings

1. In the *Server Address* text box, enter the FTP server IP address.
2. In the *Port* text box, enter the email server port number.
3. In the *User Name* text box, enter the FTP server user name.
4. In the *Password* text box, enter the FTP server manager's password.
5. From the *Mode* drop-down list, select *Active* or *Passive* (default setting). In passive mode, FTP the client initiates both connections to the server, solving the problem of firewalls filtering the incoming data port connection to the client from the server. In order to support passive mode FTP on the server-side firewall, the following communication channels must be opened:
 - FTP server's port 21 from anywhere (client initiates connection)
 - FTP server's port 21 to ports > 1023 (server responds to client's control port)
 - FTP server's ports > 1023 from anywhere (client initiates data connection to random port specified by server)
 - FTP server's ports > 1023 to remote ports > 1023 (server sends ACKs and data to client's data port)
6. Click **Save**.

9.3.1.6.4 Recording Settings

The **Recording Settings** screen is used to configure recording settings.

System > Events Handler > Recording Settings

Basic Settings

Record Status: One Shot (dropdown)

Clip Duration: 5 (5~10 sec)

Clip Size: 10 (10~20 MB)

Save

Events Handler > Recording Settings > One Shot Screen



Note:

In order to record, at least one stream must be set to *H.264*.

To configure recording settings

1. From the *Record Status* drop-down list, select *Video* or *Audio and Video*.
2. From the *Record Status* drop-down list, select *One Shot* (default) or *Continuous*.
 - If you select *One Shot*, do the following:
 - a. In the *Clip Duration* text box, enter a value from 5 to 10 seconds.
 - b. In the *Clip Size* text box, enter a value from 10 to 20 MB.
 - If you select *Continuous*, In the *Clip Size* text box, enter a value from 10 to 20 MB.

System > Events Handler > Recording Settings

Basic Settings

Record Type: Video (dropdown)

Record Status: Continuous (dropdown)

Clip Size: 10 (10~20 MB)

Save

Events Handler > Recording Settings > Continuous Screen

3. Click **Save**.

9.3.1.6.5 SD Card

The **SD Card** screen is used for configuring the microSD card. The card status is displayed in the *Mount Status* row. The status is displayed as *mounted* if the microSD card is installed and *not_mounted* if the card is not installed.

System > Events Handler > SD Card

Basic Settings

Overwrite: ON (dropdown)

Mount Status: not_mounted

Save

Events Handler > SD Card Screen

To configure the microSD card

1. From the *Override* drop-down list, select *ON*. The default is *OFF*.
2. Click **Save**.

9.3.1.6.6 Snapshot

The **Snapshot** screen is used for configuring snapshot settings.

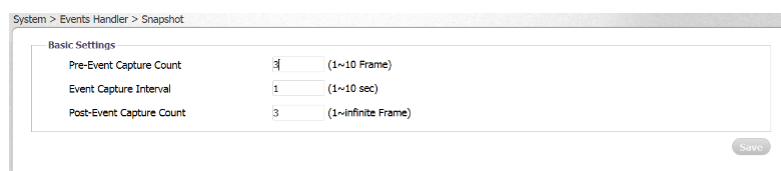

Events Handler > Snapshot Screen

To configure snapshot settings

1. In the *Pre-Event Capture Count* text box, enter the number of frames (1 to 10) to capture before taking a snapshot of an event. The default is 3 frames.
2. In the *Event Capture Interval* text box, enter the time interval (1 to 10 seconds) to capture between snapshots. The default is 1 frame.
3. In the *Post-Event Capture Count* text box, enter the number of frames (more than one) to capture after taking a snapshot. The default is 3 frames.
4. Click **Save**.

9.3.1.6.7 Sound

The sound screen enables you to upload up to 10 small PCM audio files. These sound files can be triggered upon any event that is set in the Events Source section. For example, you can trigger one warning recording that alerts an intruder that he has been detected and then a stronger warning to not to proceed if he has not left the scene. The file will be played when the audio is enabled on the Sound screen and the triggering event occurs.

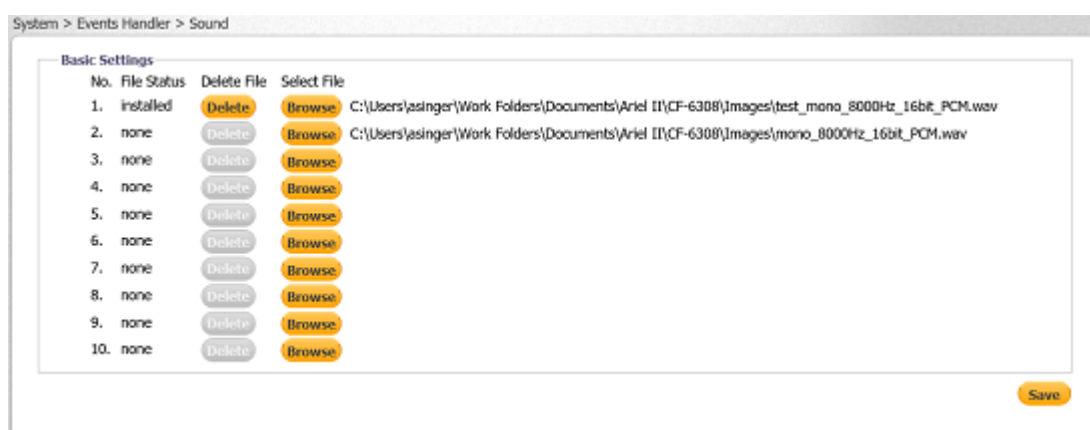

Sound Screen

9.3.2 Streaming Tab

The **Streaming** tab is used for configuring video streaming settings, privacy zones, and region of interest settings.

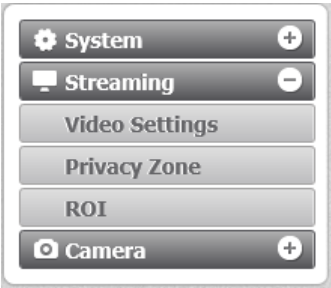

Streaming Tab

9.3.2.1 Video Settings

The CF-6308 camera supports three simultaneous streams with H.265, H.264 or MJPEG compression. MJPEG is supported on all streams and resolutions, except UHD/4K (3840x2160) on Stream1. The **Video Settings** screen is used for configuring the streams and such video parameters as resolution; video compression type and related settings; quality of service; and frame rate. Additional settings are available when using H.265 and H.264 compression.

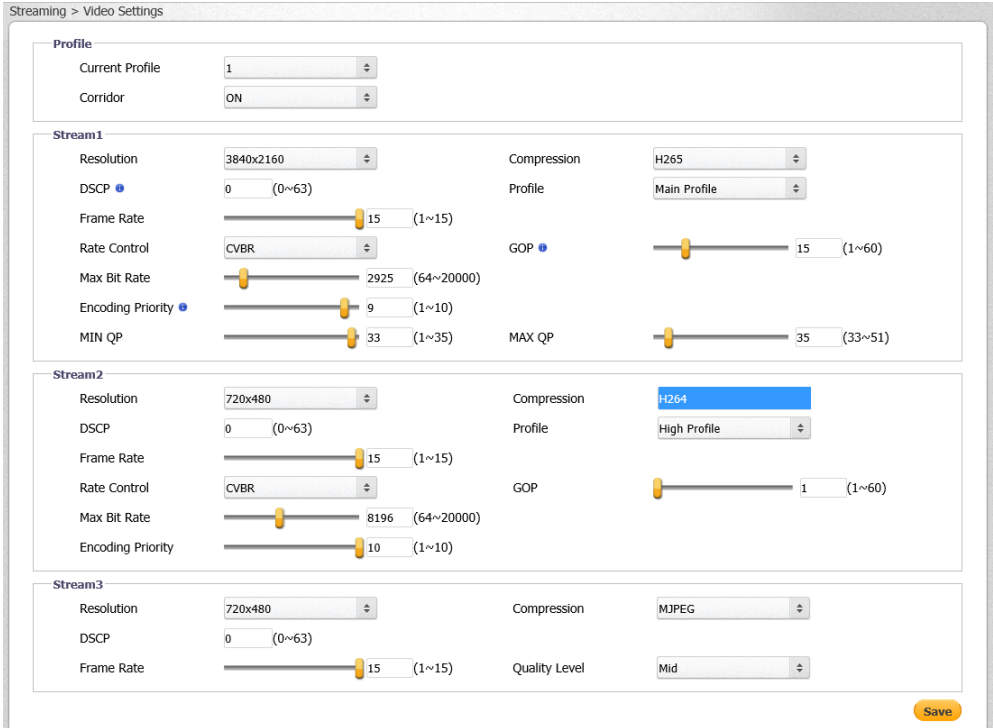

Video Settings Screen

9.3.2.1.1 Video Resolutions

The following resolutions are available:

H.265-Only	
PAL	NTSC
3840 x 2160 (25 fps)	3840 x 2160 (27 fps)
1920 x 1080 (50 fps)	1920 x 1080 (60 fps)
1280 x 720 (50 fps)	1280 x 720 (60 fps)
720 x 576 (50 fps)	720 x 480 (60 fps)

H.264-Only	
PAL	NTSC
3840 x 2160 (25 fps)	3840 x 2160 (30 fps)
1920 x 1080 (50 fps)	1920 x 1080 (60 fps)
1280 x 720 (50 fps)	1280 x 720 (60 fps)
720 x 576 (50 fps)	720 x 480 (60 fps)

H.265/H.264/MJPEG + H.265/H.264/MJPEG (NTSC)	
Stream 1	Stream 2
3840 x 2160 (15 fps @ H.264/H.265)	1920 x 1080 (15 fps @ H.264/H.265/MJPEG)
	1280 x 720 (15 fps @ H.264/H.265/MJPEG)
3840 x 2160 (25 fps @ H.264/H.265)	720 x 480 (25 fps @ H.264/H.265/MJPEG)
1920 x 1080 (60 fps @ H.264/H.265/MJPEG)	1280 x 720 (30 fps @ H.264/H.265/MJPEG)
	720 x 480 (30 fps @ H.264/H.265/MJPEG)
1280 x 720 (60 fps @ H.264/H.265/MJPEG)	1280 x 720 (30 fps @ H.264/H.265/MJPEG)
	720 x 480 (30 fps @ H.264/H.265/MJPEG)
720 x 480 (60 fps @ H.264/H.265/MJPEG)	720 x 480 (30 fps @ H.264/H.265/MJPEG)

H.265/H.264/MJPEG + H.265/H.264/MJPEG (PAL)	
Stream 1	Stream 2
3840 x 2160 (15 fps @ H.264/H.265)	1920 x 1080 (15 fps @ H.264/H.265/MJPEG)
	1280 x 720 (15 fps @ H.264/H.265/MJPEG)
3840 x 2160 (25 fps @ H.264/H.265)	720 x 576 (25 fps @ H.264/H.265/MJPEG)
1920 x 1080 (50 fps @ H.264/H.265/MJPEG)	1280 x 720 (25 fps @ H.264/H.265/MJPEG)
	720 x 576 (25 fps @ H.264/H.265/MJPEG)
1280 x 720 (50 fps @ H.264/H.265/MJPEG)	1280 x 720 (25 fps @ H.264/H.265/MJPEG)
	720 x 576 (25 fps @ H.264/H.265/MJPEG)
720 x 576 (50 fps @ H.264/H.265/MJPEG)	720 x 576 (25 fps @ H.264/H.265/MJPEG)

H.265/H.264/MJPEG + H.265/H.264/MJPEG + H.265/H.264/MJPEG (NTSC)		
Stream 1	Stream 2	Stream 3
3840 x 2160 (15 fps @ H.264/H.265)	1920 x 1080 (15 fps @ H.264/H.265/MJPEG)	720 x 480 (15 fps @ H.264/H.265/MJPEG)
	1280 x 720 (15 fps @ H.264/H.265/MJPEG)	1280 x 720 (15 fps @ H.264/H.265/MJPEG)
		720 x 480 (15 fps @ H.264/H.265/MJPEG)
1920 x 1080 (60 fps @ H.264/H.265/MJPEG)	1280 x 720 (30 fps @ H.264/H.265/MJPEG)	1280 x 720 (30 fps @ H.264/H.265/MJPEG)
	720 x 480 (30 fps @ H.264/H.265/MJPEG)	720 x 480 (30 fps @ H.264/H.265/MJPEG)
		720 x 480 (30 fps @ H.264/H.265/MJPEG)
1280 x 720 (60 fps @ H.264/H.265/MJPEG)	1280 x 720 (30 fps @ H.264/H.265/MJPEG)	1280 x 720 (30 fps @ H.264/H.265/MJPEG)
	720 x 480 (30 fps @ H.264/H.265/MJPEG)	720 x 480 (30 fps @ H.264/H.265/MJPEG)
		720 x 480 (30 fps @ H.264/H.265/MJPEG)
720 x 480 (60 fps @ H.264/H.265/MJPEG)	720 x 480 (30 fps @ H.264/H.265/MJPEG)	720 x 480 (30 fps @ H.264/H.265/MJPEG)

H.265/H.264/MJPEG + H.265/H.264/MJPEG + H.265/H.264/MJPEG (PAL)		
Stream 1	Stream 2	Stream 3
3840 x 2160 (15 fps @ H.264/H.265)	1920 x 1080 (15 fps @ H.264/H.265/MJPEG)	720 x 576 (15 fps @ H.264/H.265/MJPEG)
	1280 x 720 (15 fps @ H.264/H.265/MJPEG)	1280 x 720 (15 fps @ H.264/H.265/MJPEG)
		720 x 576 (15 fps @ H.264/H.265/MJPEG)
	720 x 576 (15 fps @ H.264/H.265/MJPEG)	720 x 576 (15 fps @ H.264/H.265/MJPEG)
1920 x 1080 (50 fps @ H.264/H.265/MJPEG)	1280 x 720 (25 fps @ H.264/H.265/MJPEG)	1280 x 720 (25 fps @ H.264/H.265/MJPEG)
		720 x 576 (25 fps @ H.264/H.265/MJPEG)
	720 x 576 (25 fps @ H.264/H.265/MJPEG)	720 x 576 (25 fps @ H.264/H.265/MJPEG)
1280 x 720 (50 fps @ H.264/H.265/MJPEG)	1280 x 720 (25 fps @ H.264/H.265/MJPEG)	1280 x 720 (25 fps @ H.264/H.265/MJPEG)
		720 x 576 (25 fps @ H.264/H.265/MJPEG)
	720 x 576 (25 fps @ H.264/H.265/MJPEG)	720 x 576 (25 fps @ H.264/H.265/MJPEG)
720 x 576 (50 fps @ H.264/H.265/MJPEG)	720 x 576 (25 fps @ H.264/H.265/MJPEG)	720 x 576 (25 fps @ H.264/H.265/MJPEG)

9.3.2.1.2 Configuring Video Settings

To configure video settings

1. From the *Current Profile* drop-down list, select 1, 2, or 3. The default is 1.

Each of the three Current Profiles has its own settings. The available parameters depend on the selected resolution. Each profile supports up to three concurrent streams (Stream1, Stream2, and Stream3), which can be configured separately to send two streams simultaneously with optimized quality and bandwidth.

2. From the *Corridor* drop-down list, select *ON* if you want to use this viewing mode. The image rotates 90° counter-clockwise (to the left) and is displayed in 16:9 aspect ratio. This mode is recommended when monitoring a long, narrow area, such as an aisle, hallway or corridor. This mode is referred to in Latitude as “90 and 270 degrees” mode when configuring the *Rotate Image* setting for the camera.

3. In the *Stream1* section, configure the following settings:
 - a. From *Resolution* drop-down list, select the desired resolutions. The default is the highest resolution for each stream.
 - b. From the *Compression* drop-down list, select *H.265* or *H.264* according to the required resolution, image quality and storage limitations. The default is *H.264*.

**Note:**

MJPEG is supported on Stream2 and Stream3 for all the available resolutions.

- i. If you selected H.265 or H.264, the following fields are displayed:

Compression	<input type="text" value="H264"/>	▼	
Profile	<input type="text" value="High Profile"/>	▼	
GOP	<input style="width: 100px;" type="range" value="30"/>	<input type="text" value="30"/>	(1~60)

H.264 Settings

- a. From the *Profile* drop-down list, select a profile: *High Profile* (H.265 and H.264) or *Main Profile* (H.265 only). Each profile targets specific classes of applications.
 - *High Profile (HP)*
High Profile is the primary profile for HD broadcast applications, providing the best trade-off between storage size and video latency. It can save 10-12% of the storage cost over Main Profile. However, it may also increase video latency, depending on the stream structure. This is the default profile.
 - *Main Profile (MP)*
This profile provides improved picture quality at reduced bandwidths and storage costs and is becoming more common as the camera processors (DSPs) become more able to handle the processing load.
- b. Set the *GOP* to a value from 1-60 (NTSC) or 1-50 (PAL). The default is 30 for NTSC and 25 for PAL (one I-Frame transmitted every second).

The GOP is a group of successive pictures within a coded video stream. Each coded video stream consists of successive GOPs. GOP structure, specifies the order in which intra-coded frames and inter-coded frames are arranged.

The GOP uses I-Frames (Intra-coded Frames), which are static image files (frames), as a reference for efficient H.265 and H.264 video compression. Transmitted video frames are compared to the I-Frame as they are transmitted. Video quality is higher when the interval between I-Frames is shorter, but the video needs more network capacity. When the interval between I-Frames is longer, the video transmission uses less bandwidth, but the video quality is lower.

ii. If you select *MJPEG*, the following fields are displayed:

Compression MJPEG ▼

Quality Level Mid ▼

MJPEG Settings

- a. From the *Quality Level* drop-down list, select *High*, *Mid*, or *Low*. The default is *Mid*. *High* produces the highest image quality, but increases the file size. *Low* produces the lowest image quality and decreases the file size.
- c. In the *DSCP* text box, enter a value between 0-63. The default DSCP value is 0 (DSCP disabled).

The DSCP (Differentiated Services Code Point) value defines the priority level or QoS (Quality of Service) for the specified type of traffic. The higher the value that is entered, the higher the priority, which reduces network delay and congestion. The camera supports the Video DSCP class, which consists of applications such as HTTP, RTP/RTSP, and RTSP/HTTP.



Note:

Remember to synchronize the QoS setting of the camera with the network router.

- d. Move the *Frame Rate* slider to the desired value. The choice of frame rates depends on the combination of the selected resolutions for the selected streams. The maximum frame is displayed by default. The higher the FPS, the smoother the motion in the video.
- e. Do one of the following:
 - If you selected *MJPEG*, continue with step 4.
 - If you selected *H.265* or *H.264*, *Rate Control* is displayed. From the *Rate Control* drop-down list, select *CBR* or *CVBR*. The default is *CBR*.
 - Select *CBR* (Constant Bit Rate) if you are monitoring simple scenes. *CBR* uses more storage capacity than *CVBR*. It wastes storage on simple scenes, while not allocating enough storage for complex sections (resulting in degraded quality). Move the slider to a number between 64 and 20000 bits per second. The default settings are *H.264* at 2925 kbps for UHD/4K, 691 kbps for HD 720p @ 15 fps, and 375 kbps for D1 @ 30 fps. The higher the bit rate, the better the image quality. Set the maximum bit rate high enough to allow for a high instantaneous bit for more complex video. A higher bit rate consumes more storage space.

- Select *CVBR* (Constrained Variable Bit Rate) to enable greater control over image parameters. CVBR uses less storage capacity than CBR. This is helpful in complex scenes, which use more bits than simple scenes. CVBR is desirable if you want an optimum bit rate from frame-to-frame with a relatively predictable file size. Continue with the following steps.
 - Set the *Max Bit Rate* to a value between 64 to 20000. The default settings are H.264 at 2925 kbps for UHD/4K @ 15 fps, 691 kbps for HD 720p @ 15 fps, and 375 kbps for D1 @ 15 fps. The higher the bit rate, the better the image quality. Set the maximum bit rate high enough to allow for a high instantaneous bit for more complex video. A higher bit rate consumes more storage space.
 - Set the *Encoding Priority*. This function enables the user to adjust the quality of the picture along a single axis. The slider ranges from 1 (low bit rate) to 10 (high picture quality). The default setting is 6.

The slider is configured based on Quantization Parameter (QP) values. Setting QP to a high value increases the bit rate and results in high compression, but this is at the expense of poor decoded image quality. Setting QP to a low value results in better decoded image quality, but with lower compression.

4. Repeat Step 3 for Stream2 and Stream3. If you are not using additional streams, select *Off* from the *Resolution* drop-down list.
5. Click **Save**.

9.3.2.2 Privacy Zone

A privacy zone enables users to cover a specific portion of the screen for privacy reasons. Users can define up to 8 privacy zones. After setting up a privacy zone, in the live view screen a frame is displayed whose color, size and position can be customized according to users' preference.

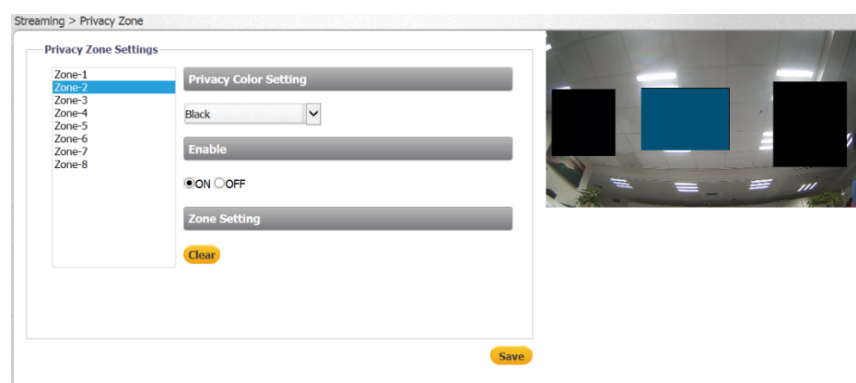

Privacy Zone Screen

To set a privacy zone

1. Select a privacy zone number from the list of *Zone-1* through *Zone-8*.
2. From the *Privacy Color Setting* drop-down list, select *Black*, *Grey*, or *White*. The default setting is *Black*.
3. In the *Enable* section, select *ON*. The default setting is *OFF*.
4. Use your mouse to draw a region of interest on the screen.
5. Click **Save**. The privacy zone is displayed on the screen. Repeat the above steps for each privacy zone.

To delete a privacy zone

1. Select the privacy zone.
2. Click **Clear**. The privacy zone is deleted.
3. Repeat the above steps for each privacy zone.

9.3.2.3 ROI

The **ROI** (Region of Interest) screen is used for configuring regions of interest on the **Live View** window.

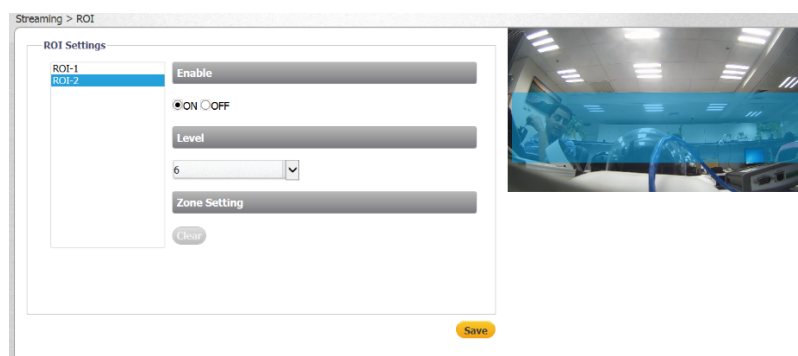

ROI Screen

The image displayed within the ROI box can be displayed with higher quality than the image outside of the box. Overall bit rate is not affected by selecting regions of interest. Enhancing the video where the quality is very important consumes more bandwidth, but enables lowering image quality and bandwidth consumption on less important zones in the scene.

To set a region of interest

1. From the *ROI* list, select *ROI-1* or *ROI-2*.
2. In the *Enable* section, select *ON*. The default setting is *OFF*.
3. Use your mouse to draw a region of interest on the screen.
4. From the *Level* drop-down list, select a number between *1-6*, where 1 is the lowest quality and 6 is the highest quality for the image within the region of interest.
5. Click **Save**. The region of interest is displayed on the screen.
6. To delete the region of interest, select *ROI-1* or *ROI-2* and click **Clear**. The ROI is deleted.

9.3.3 Camera Tab

The **Camera** tab includes three screens: [Exposure](#), [Picture Adjustment](#), and [White Balance](#).

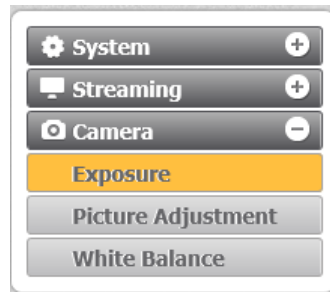

Camera Tab



Note:

Settings are saved automatically. Clicking **Reset** returns the settings to factory defaults.

9.3.3.1 Exposure Screen

The **Exposure** screen is used for configuring basic exposure settings and day/night settings. The configurable settings depend on the selected Exposure mode. In the *Exposure* section, select one of the following modes: *Auto Shutter*, *Flickerless*, *Auto Iris*, *Manual*, and *True WDR*. The choice of the Exposure mode determines the other configurable settings.

9.3.3.1.1 Auto Shutter Mode

Auto Shutter mode opens the shutter completely. Shutter speed and the AGC circuit function automatically in cooperating with the iris to achieve a consistent exposure output. The exposure priority is given to the iris. This mode is recommended to be used in indoor environments involving mixed lighting sources where the main source is fluorescent lighting combined with natural light that enters the scene through windows and other exposed areas. This is the default setting.

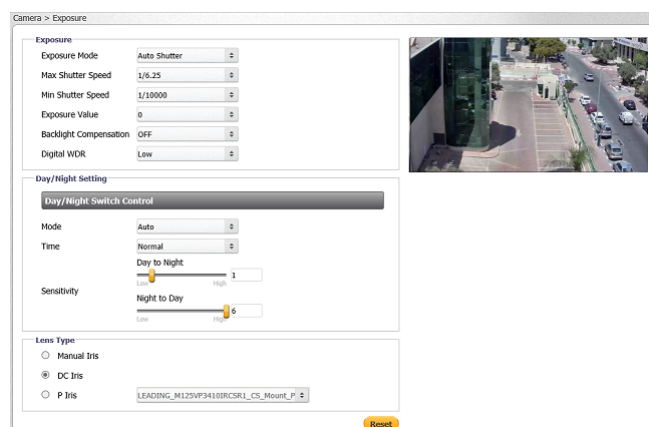

Auto Shutter Exposure Mode Settings

In the *Exposure* section, configure the following settings:

- *Max Shutter Speed* – Select a suitable shutter speed according to the environmental luminance. The following table displays the options:

Auto Shutter Max Shutter Speed	
PAL	NTSC
1/6.25	1/7.5
1/12.5	1/15
1/25	1/30
1/50	1/60



Caution:

Using a slow shutter speed causes moving objects to be blurred.

Attention:

L'utilisation de vitesses d'obturation faibles peut rendre les objets en mouvement flous.

- *Min Shutter Speed* – Select a suitable shutter speed according to the environmental luminance. The following table displays the options:

Auto Shutter Min Shutter Speed	
PAL	NTSC
1/100	1/120
1/250	1/250
1/500	1/500
1/1000	1/1000
1/2500	1/2500
1/5000	1/5000
1/10000	1/10000

- *Exposure Value* – This is a number that represents a combination of a camera's shutter speed and f-number, which brightens or darkens the scene accordingly. Select from the following options: -2, -5/3, -4/3, -1, -2/3, -1/3, 0, 1/3, 2/3, 1, 4/3, 5/3, or 2. The higher the number, the brighter the image. The default setting is 0.

- **Backlight Compensation** – In images where a bright light source is behind the subject of interest, the subject would normally appear in silhouette. The backlight function of the camera allows it to adjust the exposure of the entire image to properly expose the subject in the foreground. From the drop-down list, select one of the following options for the backlight compensation: *OFF*, *Upper 2/3rd*, *Lower 2/3rd*, *Central 1/3rd*, *Central 1/6th*, *Left*, *Right*, or *OFF* (default setting). The settings are as follows:

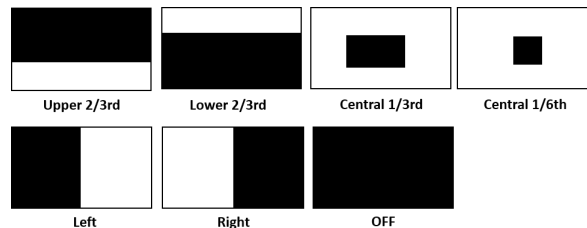

Backlight Compensation Settings

- **Digital WDR** – This function improves the image quality and amount of details in high contrast scenes. Such scenes combine areas with different lighting conditions, where some areas are very bright and others are dark. If this function was not used, the image either would be overexposed or too bright in bright areas and completely dark in dark areas. Digital WDR helps to improve image quality by producing a larger amount of details in both the dark and bright areas of the image.

Select *High*, *Medium*, *Low*, or *OFF*. When *High* is selected, the image has the highest wide dynamic range, so that the IP camera can capture the greatest scale of brightness. Selecting *OFF* disables this function. The default setting is *Medium*.

In the *Day/Night Switch Control* section, configure the following settings:

- **Mode** – The Day/Night switch activates the IR Cut (IRC) filter for electronic day/night operation. Three modes are available: *Auto*, *Color*, and *B/W*.
 - *Auto* – Select *Auto* for automatic operation according to the ambient light level. The camera converts from *Day* (color) mode to *Night* mode (monochrome/black and white) automatically at nighttime or in low-light conditions. When there is sufficient light, the camera converts automatically from *Night* mode to *Day* mode. This is the default setting.
 - *Color* – Select *Color* for daylight operation. This deactivates IR mode by putting the camera into *Day* mode.
 - *B/W* – Select *B/W* (black and white) for nighttime operation. This activates IR mode by putting the camera into *Night* mode.
- **Time** – Select *Fast*, *Normal*, or *Slow* to set the reaction time of the IRC filter. When set to *Fast*, the filter switches faster between *Day* and *Night* modes. The default setting is *Normal*.

In the *IR Control* section, configure the following settings:

- **Mode** – Select *Auto*, *ON*, or *OFF*. The default setting is *Auto*.
- **LED Brightness** – Select *High*, *Medium*, or *Low*. When set to *High*, the camera switches with almost no delay between *Color* and *B/W* modes. The default setting is *High*.

In the *Lens Type* section, select the lens type: *Manual Iris*, *DC Iris*, or *P Iris*. The selection is displayed in the text box next to the selected lens type.

Click **Reset** if you want to return to factory default settings.

9.3.3.1.2 Flickerless Mode

Flickerless mode eliminates flicker in indoor applications where fluorescent lighting is used. The darker the ambient lighting, the slower the shutter speed should be.

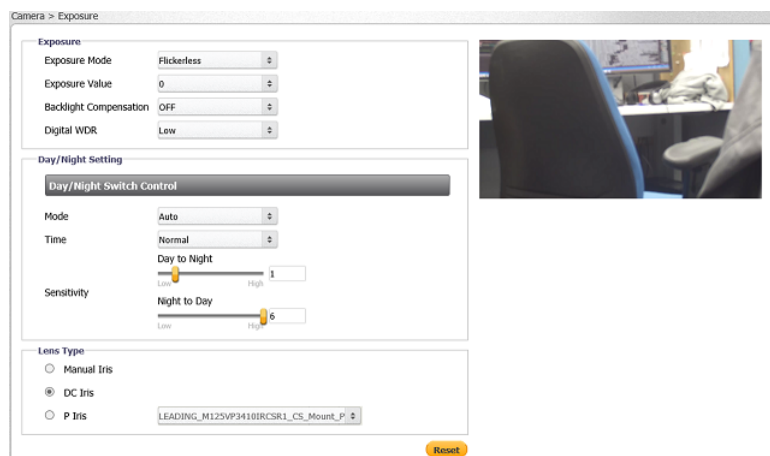

Flickerless Exposure Mode Settings

In the *Exposure* section, configure the following settings:

- *Exposure Value* – See the explanation in the [Auto Shutter](#) section above.
- *Backlight Compensation* – See the explanation in the [Auto Shutter](#) section above.
- *Digital WDR* – See the explanation in the [Auto Shutter](#) section above.

In the *Day/Night Switch Control* section, configure the following settings:

- *Mode* – See the explanation in the [Auto Shutter](#) section above.
- *Time* – See the explanation in the [Auto Shutter](#) section above.
- *Sensitivity* – See the explanation in the [Auto Shutter](#) section above.

In the *IR Control* section, configure the following settings:

- *Mode* – See the explanation in the [Auto Shutter](#) section above.
- *LED Brightness* – See the explanation in the [Auto Shutter](#) section above.

In the *Lens Type* section, select the lens type: *Manual Iris*, *DC Iris*, or *P Iris*. The selection is displayed in the text box next to the selected lens type.

Click **Reset** if you want to return to factory default settings.

9.3.3.1.3 Auto Iris Mode

Auto Iris mode sets a fixed exposure while other parameters can change.

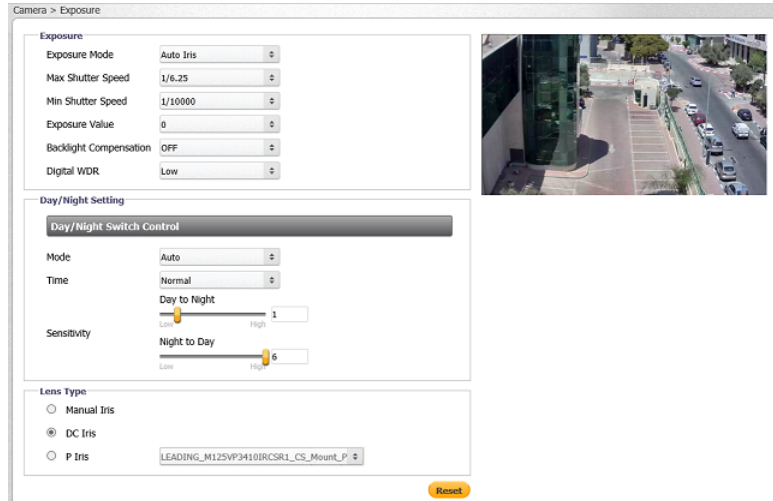

Auto Iris Exposure Mode Settings

In the *Exposure* section, configure the following settings:

- *Max Shutter Speed* – Select a suitable shutter speed according to the environmental luminance. The following table displays the options:

Auto Iris Max Shutter Speed	
PAL	NTSC
1/6.25	1/7.5
1/12.5	1/15
1/25	1/30
1/50	1/60



Caution:

Using a slow shutter speed causes moving objects to be blurred.

Attention:

L'utilisation de vitesses d'obturation faibles peut rendre les objets en mouvement flous.

- *Min Shutter Speed* – Select a suitable shutter speed according to the environmental luminance. The following table displays the options:

Auto Iris Min Shutter Speed	
PAL	NTSC
1/100	1/120
1/250	1/250
1/500	1/500
1/1000	1/1000
1/2500	1/2500
1/5000	1/5000
1/10000	1/10000

- *Exposure Value* – See the explanation in the [Auto Shutter](#) section above.
- *Backlight Compensation* – See the explanation in the [Auto Shutter](#) section above.
- *Digital WDR* – See the explanation in the [Auto Shutter](#) section above.

In the *Day/Night Switch Control* section, configure the following settings:

- *Mode* – See the explanation in the [Auto Shutter](#) section above.
- *Time* – See the explanation in the [Auto Shutter](#) section above.
- *Sensitivity* – Use the slider to set the sensitivity between *Low* and *High* when switching from *Day* to *Night* mode or *Night* to *Day* mode. When set to *High*, the camera automatically switches between *Day* and *Night* modes upon minor changes in light intensity. When set to *Low*, the camera automatically switches between *Day* and *Night* modes upon major changes in light intensity.

In the *IR Control* section, configure the following settings:

- *Mode* – See the explanation in the [Auto Shutter](#) section above.
- *LED Brightness* – See the explanation in the [Auto Shutter](#) section above.

In the *Lens Type* section, select the lens type: *Manual Iris*, *DC Iris*, or *P Iris*. The selection is displayed in the text box next to the selected lens type.

Click **Reset** if you want to return to factory default settings.

9.3.3.1.4 Manual Mode

Manual mode opens the iris completely with a fixed gain. This mode should only be used in indoor scenes with consistent lighting. Manual mode requires the user to set fixed values for shutter and gain levels. Increasing the value of the fixed shutter increases the amount of light entering the sensor, which allows a brighter and more detailed image. In a similar manner, utilizing gain and increasing its level increases the sensitivity of the image sensor, which brightens the image and add details. This increases the level of noise in the image.



Manual Exposure Mode Settings

In the *Exposure* section, configure the following settings:

- *Shutter Speed* – Select the shutter speed from the following options:

Manual Shutter Speed		Manual Shutter Speed	
PAL	NTSC	PAL	NTSC
1/25	1/30	1/1000	1/1000
1/50	1/60	1/2500	1/2500
1/100	1/120	1/5000	1/5000
1/250	1/250	1/10000	1/10000
1/500	1/500		

- *Gain* – Set the gain between 0-48 dB. Increasing the gain lightens dark pictures resulting from low-level lighting. The default is 0.
- *Digital WDR* – See the explanation in the [Auto Shutter](#) section above.

In the *Day/Night Switch Control* section, configure the following setting:

- *Mode* – See the explanation in the [Auto Shutter](#) section above.

In the *IR Control* section, configure the following settings:

- *Mode* – See the explanation in the [Auto Shutter](#) section above.
- *LED Brightness* – See the explanation in the [Auto Shutter](#) section above.

In the *Lens Type* section, select the lens type: *Manual Iris*, *DC Iris*, or *P Iris*. The selection is displayed in the text box next to the selected lens type.

Click **Reset** if you want to return to factory default settings.

9.3.3.1.5 True WDR Mode

True WDR mode is used to set a fixed exposure while other parameters can change. In this mode, the camera's shutter speed works automatically to achieve a consistent video output level in scenes with high contrast or changing light issues.

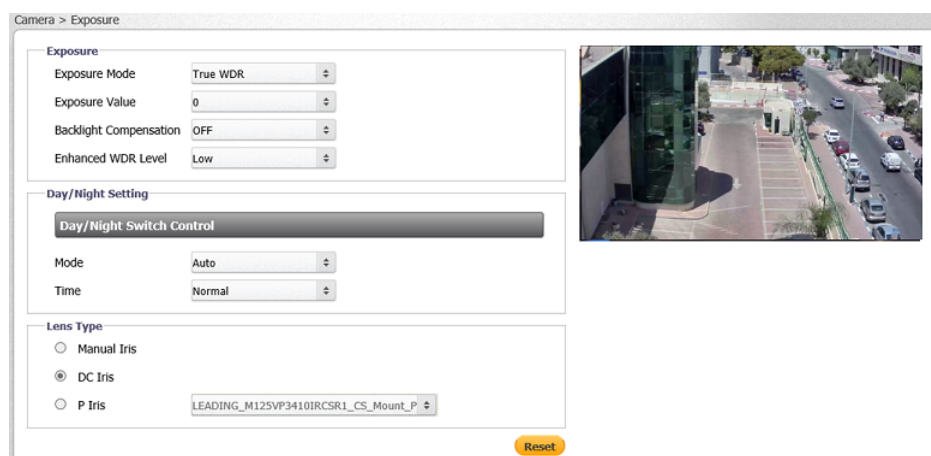

True WDR Exposure Mode Settings

When activated, a combination of slow- and fast-exposure shutters is used to create a new image with a wide dynamic range. The camera uses an algorithm to determine the optimal mix of light and dark regions within the scene from the two shutters in order to adjust the wide dynamic range of the scene and achieve a greater scale of brightness.



True WDR On



True WDR Off

In the *Exposure* section, configure the following settings:

- *Exposure Value* – See the explanation in the [Auto Shutter](#) section above.
- *Backlight Compensation* – See the explanation in the [Auto Shutter](#) section above.
- *Enhanced WDR Level* – Select the setting that provides the ideal brightness according to the environmental luminance: *High*, *Medium*, *Low* or *Off* (default). Selecting *High* provides the most brightness, while *Low* reduces brightness.

In the *Day/Night Switch Control* section, configure the following settings:

- *Mode* – See the explanation in the [Auto Shutter](#) section above.
- *Time* – See the explanation in the [Auto Shutter](#) section above.
- *Sensitivity* – See the explanation in the [Auto Shutter](#) section above.

In the *IR Control* section, configure the following settings:

- *Mode* – See the explanation in the [Auto Shutter](#) section above.
- *LED Brightness* – See the explanation in the [Auto Shutter](#) section above.

In the *Lens Type* section, select the lens type: *Manual Iris*, *DC Iris*, or *P Iris*. The selection is displayed in the text box next to the selected lens type.

Click **Reset** if you want to return to factory default settings.

9.3.3.2 Picture Adjustment

The **Picture Adjustment** screen enables you to configure picture quality, color and mirror flip settings.

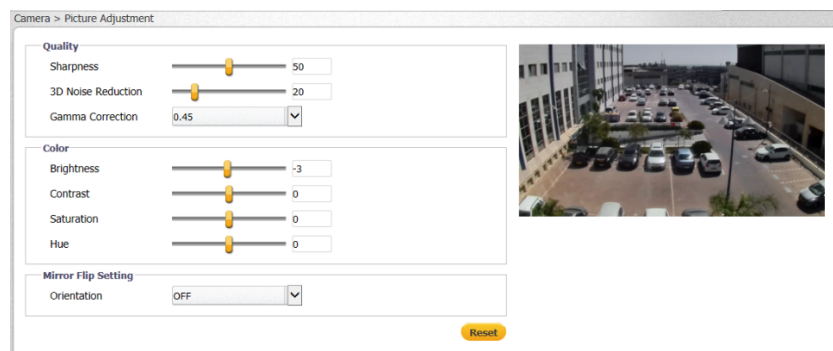

Picture Adjustment Screen

Settings are saved automatically after configuration. To restore settings to factory default, click **Reset**.

To configure quality settings

1. In the *Quality* section, configure the following settings:
 - *Sharpness* – Set the slider between *0-100*, which provides the highest sharpness around the edges and for small features. The default setting is *40*.
 - *3D Noise Reduction* – Set the slider between *0-100*. The default setting is *20*.
 - *Gamma Correction* – From the drop-down list, select *0.45* or *1*. The default setting is *0.45*. Gamma correction is used to ensure faithful reproduction of an image. When gamma = 1, the original image is the same as the image displayed on your screen. If the gamma is set at *0.45*, there will be less contrast.

To configure color settings

1. In the *Color* section, configure the following settings:
 - *Brightness* – Set the image brightness between *-100* to *100*, which provides the highest brightness. The default is *0*.
 - *Contrast* – Set the image contrast between *-100* to *100*, which provides the highest contrast. The default is *0*.
 - *Saturation* – Set the image saturation *-100* to *100*. The lower the number, the closer the image is to a grayscale (i.e., monochrome or black-and-white) image. The higher the number, the deeper the color image (i.e., reds will be redder and blues will be bluer). The default is *0*.

- *Hue* – Set the image hue between *-100* to *100*, which provides the deepest hue. The default is *0*.

To configure mirror flip settings

1. In the *Mirror Flip Setting* section, from the *Orientation* drop-down list, select one of the following:
 - *Flip* – This setting flips the image upside-down.
 - *Mirror* – This setting views the image from a different angle.
 - *Both* – This setting views the image upside-down from a different angle.
 - *OFF* (default)

9.3.3.3 White Balance

The **White Balance** screen is used to create the best color rendition.

To set the White Balance mode

1. From the *Mode* drop-down list, select one of the following options:
 - *ATW* – In *ATW* mode, color is continuously adjusted according to the color temperature of the scene illumination. This is the default setting.



White Balance ATW Mode Screen

- *Auto* – In *Automatic* mode, the color in a scene is automatically adjusted according to the ambient lighting between 2500°K to 10000°K.

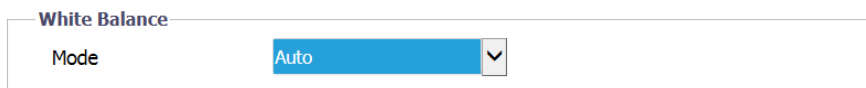

White Balance Auto Mode Screen

- *Manual* – In *Manual* mode, white balance is adjusted on-screen according to the type of lighting.

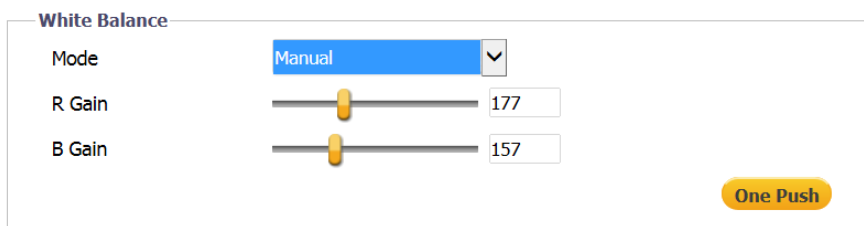

White Balance Manual Mode Settings

- a. To set the gain values, adjust the following settings:
 - R Gain: Adjusts the red color in the image from *0* to *511*. The higher the number, the redder the image. The default setting is *64*.
 - B Gain: Adjusts the blue color in the image from *0* to *511*. The higher the number, the bluer the image. The default setting is *64*.
- b. To quickly balance the color, click **One Push**.

9.4 Logout

Selecting the **Logout** link on the Home page to close the session. The following message appears:

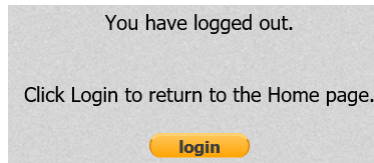

Logout Message

Upon clicking **Login**, the **Login** dialog box opens. See Figure: [Login Dialog Box](#).



10 Appendices

The following appendices are included in this section:

- [Technical Specifications](#)
- [Internet Security Settings on Internet Explorer](#)
- [Installing UPnP Settings on Internet Explorer](#)
- [Deleting Temporary Internet Files on Internet Explorer](#)
- [Installing and Deleting the Web Player](#)
- [Network Settings](#)
- [Troubleshooting](#)
- [Acronyms and Abbreviations](#)
- [Optional Lenses](#)

10.1 Technical Specifications

Following are the CF-6308 technical specifications:

Camera			
Image Sensor		1/2.5" Progressive Scan CMOS Sensor	
Effective Pixels (H x V)		3840 x 2160 pixels	
Sensor resolution		3840 x 2160 pixels	
Shutter Speed		1/6.25 (PAL) or 1/7.5 (NTSC) to 1/10,000 with up to 32x sensitivity boost in color or night mode	
Sensitivity	Color Mode	0.07 lux	
	B/W Mode	0.01 lux	
Video Compression		Dual-stream H.265 (Main Profile), H.264 (Main and High Profile), or MJPEG (Stream2 and Stream 3 only)	
Video Resolution (H.265, H.264, and MJPEG)	Stream 1	Stream 2	Stream 3
	UHD (4K) @ H.264/ H.265, Full HD 1080p, HD 720p, or D1 @ H.264/H.265/MJPEG	Full HD 1080p, HD 720p or D1 @ H.264/H.265/MJPEG	HD 720p or D1 @ H.264/H.265/MJPEG
Analog Video Output		1V p-p continuously enabled (PAL or NTSC), 1x BNC 75Ω connector	
Maximum Performance (16:9)		UHD @ 15 FPS @ H.264/H.265 + Full HD 1080p + D1 @ 15 FPS @ H.264/H.265/MJPEG (default configuration)	
Bit Rate Control		CBR (Constant Bit Rate) and SVBR (Shaped Variable Bit Rate): 64 – 20,480 Kbps (with H.265 and H.264)	
S/N Ratio		>50dB (AGC off)	
Lens			
Lens Type		CS Mount for P-Iris and DC-Iris lens with external back focus control (lens not supplied)	

Camera		
Operation		
Image Settings	Exposure Control	Yes
	Gain Control	Yes
	Backlight Compensation	Yes
	Gamma Correction	0.45, 1
	Brightness	Manual
	Contrast	Manual
	Saturation	Manual
	Hue	Manual
	Sharpness	Manual (0-100)
	White Balance	ATW/Auto/Manual/One Push
	Wide Dynamic Range (WDR)	sWDR
	3D Noise Reduction	Manual (0-100)
	Privacy Mask	Yes (3 masks)
	Orientation	0°, 180°
	True Day/Night	Removable IR Cut Filter
Mirror Flip	Flip/Mirror/Both/Off	
Audio	G.711 a-Law, G.711 μ -Law, and AAC Audio Compression	
	Audio Intensity Detection	
	1x Audio-in/1x Audio-out	
Alarm	1x Alarm-in/1x Alarm-out	
Languages	English, Arabic, Czech, Simplified Chinese, Traditional Chinese, French, German, Hungarian, Italian, Japanese, Polish, Portuguese, Russian, Spanish	
MicroSD Card Recording	Up to 32GB microSDXC (card not included)	

Camera	
Analytics	
Motion Detection	When the unit detects motion, a corresponding action is triggered. On/Off, by zone, object size, sensitivity level, and schedule.
Defocus	Notifications and On-Event Recording. Includes configurable alarms and broad range of recording on detection of video and snapshots.
Tampering Alarm	When the unit detects tampering, a corresponding action is triggered. On/Off, on-event notification, sensitivity level, schedule, recording to SD card, and more are supported as events in Latitude.
Network	
Interface	1 x 10/100 Mbps Ethernet RJ45 interface (IEEE 802.3/802.3u)
Services and Protocols	IPv4, IPv6 (including IPv6 addressing, IPv6 router advertisement, IPv6 DHCP, and IPv6 web support), TCP, UDP, IGMP, ICMP, DHCP, DNS, DDNS, RTP, RTSP, RTCP, NTP, SNTP, SMTP, HTTP, HTTPS, FTP, PPPoE, QoS, SNMPv1/v2c/v3 (MIB-II), UPnP, ONVIF Profile S and Profile G, LDAP
Video Streaming	RTSP/RTP
Event Notification	HTTP event query, HTTP event client pulling
Event Storage	Recordings and snapshots
Password Levels	User and Administrator
Security	802.1X (EAP-MD5, EAP-TTLS, EAP-PEAP), IP address filtering, SSL, SNMPv3 (AES, DES, MD5, and SHA)
Firmware Upgrade	Flash memory for upgrading camera firmware via HTTP
Operating Systems	Windows Server 2003, Windows Server 2008 (32-bit version); Windows 7, 8, 8.1, and 10 (all 64-bit versions)
Internet Browser	Microsoft Internet Explorer 10 (32-bit version) and above; Microsoft Edge 38 and above; Chrome v.55 and above; Firefox v.50 and above

Camera			
Power			
Source	802.3af PoE (Class 3); 12VDC; 24VAC		
Power Consumption	PoE	12VDC	24VAC
	8W	9.3W	8.2W
Power Input	48VDC, 0.2A; 12VDC, 0.6A; 24VAC 0.5A		
Physical			
Dimensions (L x H x W)	100 x 63 x 76mm (4 x 2.5 x 3")		
Weight	0.61 kg (1.34 lbs.)		
Enclosure	Aluminum camera body with plastic front cover		
Environmental Specifications			
Storage Temperature	-40° to 60°C (-40° to 140°F)		
Operating Temperature	-20° to 50°C (-4° to 122°F) with PoE		
Operating Humidity	Up to 90% relative humidity (non-condensing)		
Certifications			
Safety	EN61000-6-3:2007+A1:2011, Class B; EN50130-4:2011, Class B; UL 60950-1 and 60950-22		
Electromagnetic Interference (EMC)	IEC 60950-1:2005 (Second Edition) + Am 1:2009 + Am 2:2013; EN 60950-1:2006 + A11:2009 + A1:2010 + A12:2011 + A2:2013; EN55022:1998 Class A; FCC 47 CFR Part 15 Subpart B, Class B; ICES-003; EMC Directive 2004/108/EC; CISPR 22		
Environmental	RoHS compliant, excluding Pb in 2LI (lead on second level interconnect); WEEE Directive 2012/19/EU; REACH		

10.2 Internet Security Settings on Internet Explorer

If the existing ActiveX certificate is old or invalid, the ActiveX installation may fail in systems that are not connected to the Internet, which therefore cannot update their security certificates. In this case, the Setup.exe file in the ActiveX folder on the supplied CD should be run. You can then continue with the installation.

If ActiveX control installation is blocked, either set Internet security level to default or change ActiveX controls and plug-in settings.

To set the default Internet security level

1. Start Internet Explorer (IE).
2. From the Command Bar toolbar, select **Tools** and select *Internet Options* from the menu that appears.

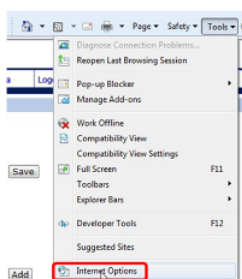

Command Bar Toolbar – Select Internet Options

3. In the **Internet Options** window that appears, select the **Security** tab.
4. Select  in *Select a zone to view or change security settings*.
5. If the settings are not defined as default, select *Default Level* and move the *Allowed* levels for this zone slider to *Medium-high* and select **OK**.

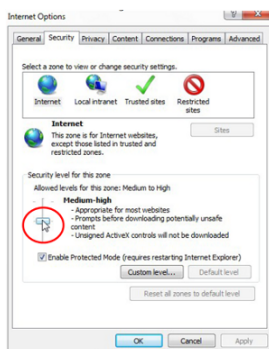

Internet Options > Security Tab

6. Close all browsers and reopen so that the settings take effect.

Configuring ActiveX Controls and Plug-in Settings

To create a custom level

1. Start Internet Explorer (IE).
2. From the Command Bar toolbar, select **Tools** and select *Internet Options* from the menu that appears.

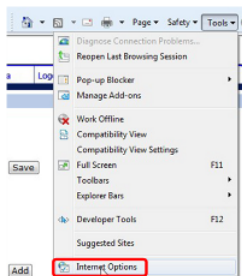

Command Bar Toolbar – Internet Options

3. In the **Internet Options** window that appears, select the **Security** tab.



4. If not already selected, select **Internet**, then select *Custom Level*. The **Security Settings-Internet Zone** dialog box opens.
5. In the **Security Settings-Internet Zone** dialog box, under **ActiveX controls and plug-ins** set all the following options to **Enable** or **Prompt**:

<ul style="list-style-type: none"> • Automatic prompting for ActiveX controls • Binary and script behaviors • Download signed ActiveX controls • Download using ActiveX controls • Initialize and script ActiveX not marked as safe • Run ActiveX controls and plug-ins • Script ActiveX controls marked safe for scripting 	
--	--

Security Settings-Internet Zone Screen

6. Click **OK** to accept the settings and close the **Security** tab.
7. Click **OK** to close the **Internet Options** window.
8. Close the browser window and restart IE again to access the camera.

10.3 Installing UPnP Settings on Internet Explorer

Open the **Desktop > Network** window. Follow the instructions below to enable UPnP so that the camera can be discovered and displayed in Network locations under *Other Devices*:

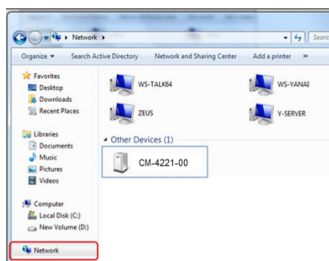

Control Panel > Network Window

To enable UPnP discovery in Windows 7, 8, and 8.1

1. Click  (Start) and select *Control Panel*.
2. Click *Network and Internet*.



3. Click *Network and Sharing Center*.

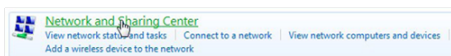

4. Click *Change advanced sharing settings*.

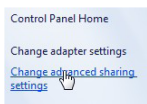

5. Expand the Home or Work node, select *Turn on network discovery*.

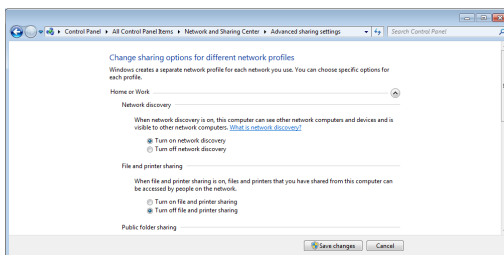

Windows 7, 8, and 8.1 Advanced Sharing Settings Dialog Box

6. Click **Save Changes**.

Note:

Network discovery requires that the DNS Client, Function Discovery Resource Publication, SSDP Discovery, and UPnP Device Host services are started, that network discovery is allowed to communicate through Windows Firewall, and that other firewalls are not interfering with network discovery.

To enable UPnP discovery in Windows 10

1. Open the Control Panel.
2. Click *Network and Sharing Center*.

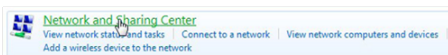

3. Click *Change advanced sharing settings*.

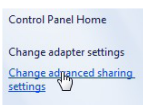

4. In the *Network discovery* and *File and printer sharing* sections, select *Turn on network discovery*.

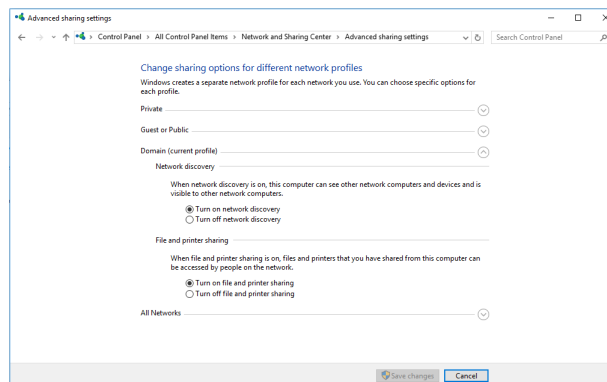

Windows 10 Advanced Sharing Settings Dialog Box

5. Click **Save Changes**.

To check that the UPnP Device Host services are running

1. Click  (Start) and type in the *Search* box **services.msc**. The **Services (Local)** dialog box appears.

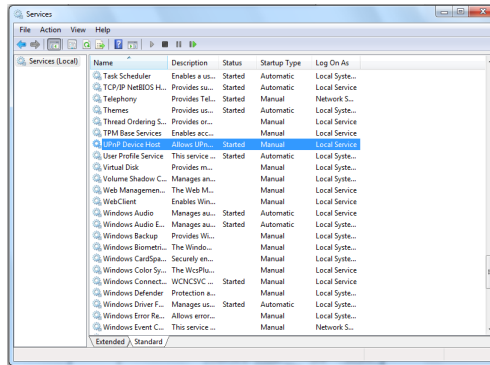

Windows Services (Local) Dialog Box

2. In the **Services (Local)** dialog box, scroll down the list to *UPnP Device Host* and verify that it shows the status *Started*. If *Started* is not displayed, right-click and select **Start** from the shortcut menu.

10.4 Deleting Temporary Internet Files on Internet Explorer

To improve browser performance, it is recommended to clean up all of the temporary Internet files.

To delete temporary Internet files

1. In Internet Explorer (IE), from the Command Bar toolbar, click **Tools** and select *Internet Options* from the menu that appears.

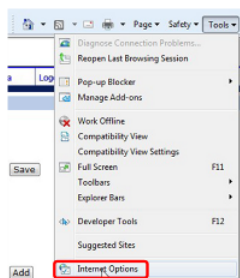

Command Bar Toolbar – Select Internet Options

2. In the **General** tab in the *Internet Options* dialog box, click **Delete**.
3. In the **Delete Browser History** dialog box that appears, select *Temporary Internet files*. Uncheck *Cookies* and *History* to keep this data. Then click **Delete**.

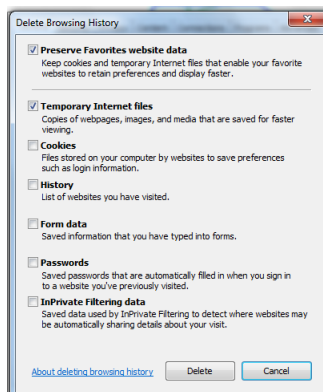

Delete Browser History Dialog Box

10.5 Installing and Deleting the Web Player

The Web Player enables you to view the camera's user interface.

- The Web Player installs automatically with Edge, Chrome, and Firefox browsers.
- If this is a first-time installation of the camera with Internet Explorer, the Web Player installation wizard opens after accessing the camera.

Installing the Web Player with Internet Explorer

If your browser is Internet Explorer, a message is displayed, requesting you to download the Microsoft Visual C++ 2008 Redistributable package and/or to install the Ariel Player add-on.

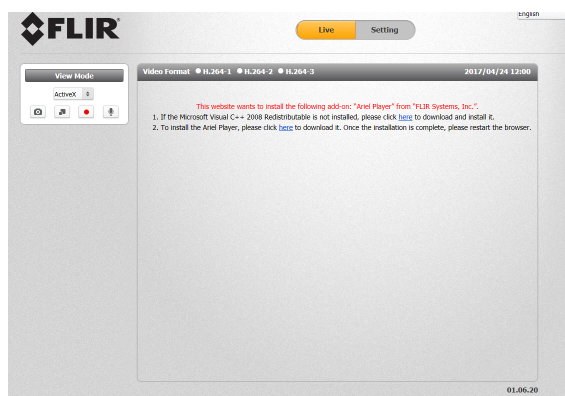

Web Interface with Internet Explorer Browser

- If the Microsoft Visual C++ 2008 Redistributable package is not installed in your computer, click the link to install it.
- If the Microsoft Visual C++ 2008 Redistributable folder is installed in your computer, install the Web Player.

To install the Web Player

1. Click “*here*” on the screen to download the Ariel Player plug-in. The Ariel Player plug-in information bar opens.



Run Ariel Player Plug-in Information Bar

- Click **Run** on the information bar to install the Ariel Player plug-in. The Windows Installer opens and the **Ariel Player Wizard** dialog box is displayed.

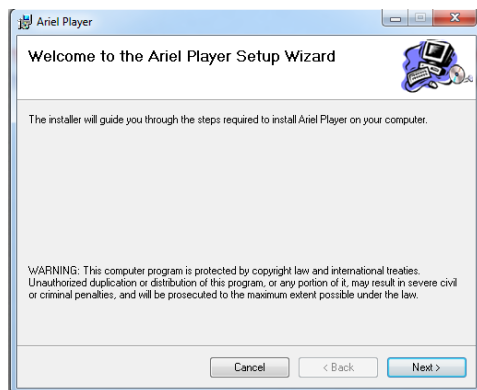

Web Player Installation Wizard

- Click **Next** to install the Ariel Player plug-in on your PC.

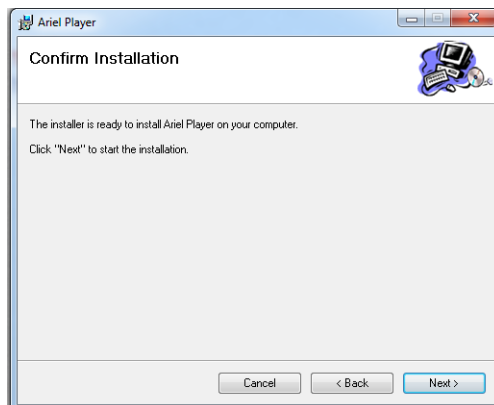

Ariel Player Setup Wizard Screen 2

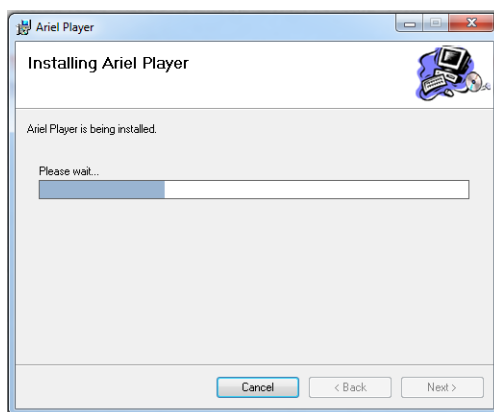

Ariel Player Setup Wizard Screen 3

- Click **Close** when the **Installation Complete** dialog box is displayed.

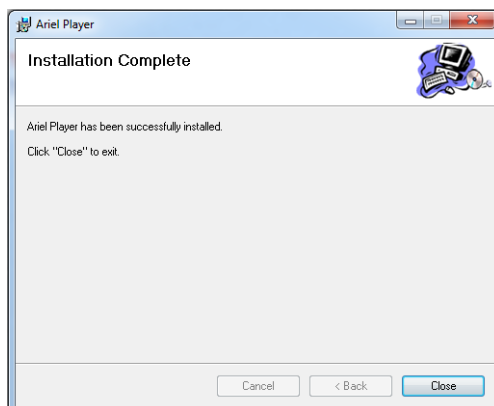

Ariel Player Setup Wizard Screen 4

- Click **Close**. *Ariel Player* is displayed in the **Programs and Features** window.

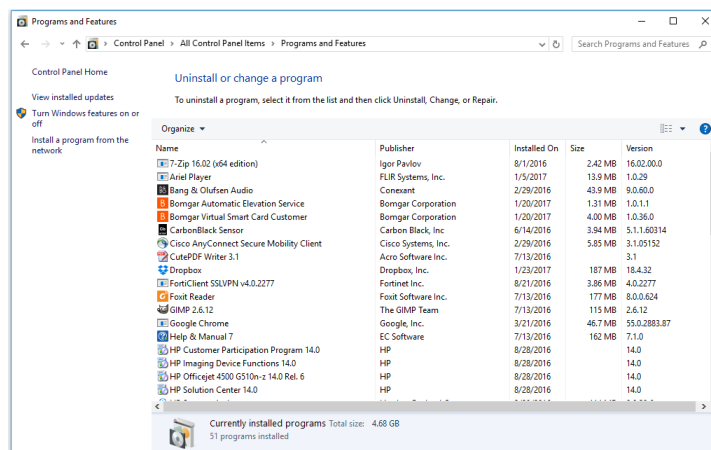

Programs and Features Window

- Click **Run** on the second information bar that is displayed after the download has completed.



Ariel Player Plug-in Download Completed Information Bar

- If you promptly close your browser, the [Live View](#) screen is displayed.
- If you do not promptly close your browser, a dialog box opens, prompting you to restart your computer, in order to save changes.

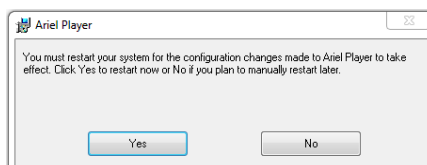

Ariel Player Restart System Dialog Box

- Click **Yes**. The computer reboots and the **Rebooting Completed** message appears.
- Click **OK**. The **Live View** screen is displayed.

Deleting the Web Player

Users who have previously installed the Web Player in the PC should first delete the existing player file from the PC and then install the new Web Player before accessing the camera.

To delete an existing Web Player file on Windows 7, 8, and 8.1

1. Click  **Start** and select **Control Panel**. The **Control Panel** opens.
2. In the Control Panel, click **Uninstall a program**.



3. From the **Programs and Features** window, select *Ariel Player*.
4. On the banner bar, click **Uninstall**.
5. If prompted to confirm the Uninstall, click **Yes**.

After deleting the previous player file, you must clear your computer's cache memory.

To delete an existing Web Player file on Windows 10

1. Click  **Start** and select **Control Panel**. The **Control Panel** opens.
2. In the Control Panel, select **Programs and Features**.
3. From the installed program list, select *Ariel Player*.
4. On the banner bar, click **Uninstall**.
5. If prompted to confirm the Uninstall, click **Yes**.

After deleting the previous player file, you must clear your computer's cache memory.

To clear your computer's cache memory

1. In the Control Panel, click **Internet Options**. The **Internet Properties** dialog box opens.

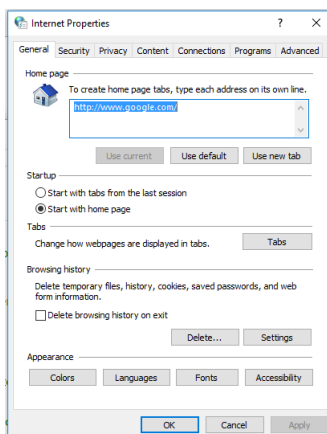

Internet Properties Window

- From the *Browsing History* section, click **Delete**. The **Delete Browsing History** dialog box opens.

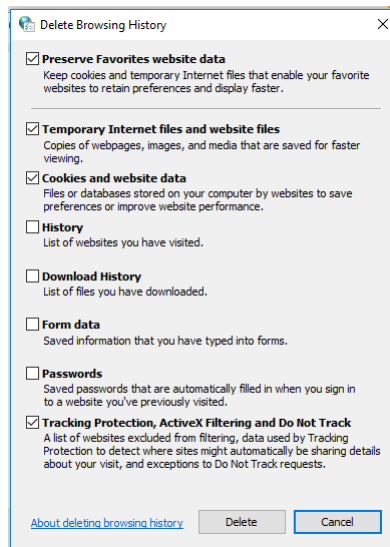

Delete Browsing History Dialog Box

- From the **Delete Browsing History** dialog box, check *Preserve Favorites website data*, *Temporary Internet files and website files*, *Cookies and website data*, and *Tracking Protection, ActiveX Filtering and Do Not Track*.
- Click **Delete**. The **Internet Properties** dialog box opens.
- Click **OK**. Your computer's cache memory is deleted. After the cache is cleared, the Web Player installation wizard opens.
- Follow instructions above to install the Web Player.

10.6 Network Settings

Following are the network protocols and ports used by the camera:

Protocol	Port	Usage
FTP	21	Uploading files to the FTP server
HTTP	80	Sending commands, requests, replies and notifications
HTTPS	443	Using the secure socket protocols SSL/TLS over HTTP. HTTPS must be enabled if your network uses SNMPv3.
Multicast Streaming	As defined in the units	Video/streaming (multicast). Uses the ONVIF address defined by the Video Management System
Multicast UDP	9766	Unit self-publishing. Uses IP address 224.9.9.9
NTP	123	Time synchronization with a network time server using SNTP
RTSP	554	RTP session setup
RTP	2000 to 65535	Multimedia streaming
SNMP	161	IP management system
SNMP Trap port	162	Sending alarm event and exception messages to the surveillance center

10.7 Troubleshooting

This section provides useful information and remedies for common situations where problems may be encountered.

Problem	Possible Solution
No network connection	<p>Hardware issues:</p> <ul style="list-style-type: none"> • Check that the network is working and the unit is powered on. • Check that the network (Ethernet) cable is properly attached to the unit. • Confirm that the network cables are not damaged and replace if necessary. <p>IP Address issues:</p> <ul style="list-style-type: none"> • Change the default IP address/addresses of the unit. • From the PC running the web browser, ping the unit IP address and confirm that it can be reached. • Confirm that the network settings/firewalls are set according to the requirements. • The camera might be located on a different subnet. Contact your IT administrator to get the IP address of the camera.
How do I find IP address of my unit?	<ul style="list-style-type: none"> • Check the network DHCP server IP address assignments and lease. • Alternatively, move the camera to an isolated network and make sure camera gets DHCP address and is accessible. Move the camera back to the network and test it. If you still have issues, reset the camera physically by pressing the reset button on the rear of the camera and test the camera again. This will ensure the camera releases the IP address.
The IP address responds to a ping on the network from the workstation but does not show in the Discovery List	<ul style="list-style-type: none"> • Disconnect the unit's Ethernet 10/100 port or turn the power to unit off, and then ping the IP address again. If the IP address responds, there is another device using the IP address. Consult with your network administrator to resolve the conflict. • Check the network port and ensure that it is working OK. • Ensure that the switch ports provide the necessary power.
The unit IP address is in use by another computer (collision)	<ul style="list-style-type: none"> • Check the DHCP settings. Obtain a new IP address using DHCP. Ensure this is a unique IP address. • Alternatively, change the unit IP address after connecting to it directly (not through the system network).

Problem	Possible Solution
Cannot login to the camera	<ul style="list-style-type: none"> • Check the login user ID of the user or admin. • Check the login password of the user or admin.
No video image displayed on the main menu or the view menu of the web interface	<ul style="list-style-type: none"> • Reset the browser security settings to the default value. • Check that the correct port was configured. The default port is 554.
Bad output video quality	<ul style="list-style-type: none"> • Check that the network cable is connected securely. • Check that the camera settings are correct on the camera and in the unit. • Check that the camera lens is clean and unobstructed. • Check that the cable length is within specification.
Streaming video image is hanging (stopped)	<ul style="list-style-type: none"> • Confirm the unit's video streaming settings. • Refresh your browser screen (F5). • Check that the bandwidth and bit rate settings of the network are set properly. • Check that other processes and applications are not causing undue latency. • Check that the firewall analysis or blocking is not interfering with the video stream and supports the required ports and communication protocols.
Bluish picture in an indoor scene (possibly mixing indoor and outdoor lighting)	Adjust the White balance configuration to <i>Auto</i> . If the lighting in the scene is fixed, manually adjust the White balance to an acceptable image.
Reddish picture and incorrect colors in the image	Check the PoE power supply and associated network cables. Connect directly to the PoE and compare the images. If the problem persists, contact support.

10.8 Acronyms and Abbreviations

Abbreviation	Description
802.1X	Network Access Control Port-based authentication standard
AES	Advanced Encryption Standard
AGC	Automatic Gain Control
DES	Data Encryption Standard
DHCP	Dynamic Host Control Protocol
EAP	Extensible Authentication Protocol
FTP	File Transfer Protocol
H.264	Video Compression Standard
HTTP	Hypertext Transport Protocol
HTTPS	Hypertext Transport Protocol Secure
IP	Internet Protocol
JPEG	Joint Photographic Experts Group
LDAP	Lightweight Directory Access Protocol
MD5	Message-Digest 5 encryption algorithm
MJPEG	Motion Joint Photographic Experts Group
NTP	Network Time Protocol
ONVIF®	Open Network Video Interface Forum
OSD	On-Screen Display
ROI	Region of Interest
RTP	Real-time Transport Protocol
RTSP	Real-time Streaming Protocol
SHA	Secure Hash Algorithm
TCP	Transmission Control Protocol
UDP	User Datagram Protocol
UPnP	Universal Plug and Play

10.9 Mounting and Lens Accessories

The camera body is shipped without a lens. The following lenses and mounting accessories are available. For more information on available options, contact your FLIR sales representative or visit www.flir.com/security.

Part Number	Item
<p>CF-X200-01</p> 	<p>Outdoor Fixed Camera Housing</p> <ul style="list-style-type: none"> • Equipped with heater and fan • 24VAC @ 20W • Aluminum with Sunshield • -30 to +50C (-22 to +122F) • 140 x 112 x 340mm/5.5 x 4.4 x 13.4" (W x H x L) • 1.51Kg/3.4 lbs.
<p>CF-X200-POLE</p> 	<p>Pole Mount Option for CF-X200-01 Housing</p>
<p>CF-L304-11-P</p>	<p>P-Iris Lens 1/2.5", F1.6, 3.4-10mm focal length, CS mount CCD/CMOS sensor 4:3 aspect ratio FoV (W - T): 115°-45° diagonal, 92°-36° horizontal, 67°-27° vertical Ø 33 x 33.87 x 45.5mm (Ø x L x W)</p>
<p>CF-L308-11-P</p> 	<p>DC-Iris/P-Iris Motorized Vari-Focal IR Lens 1/1.8", F1.4, 3.8-12mm focal length, CS mount FoV (W- T): 154.4° - 45.5° diagonal, 117.9° - 37.3° horizontal, 73.8° - 25.1° vertical 6.44MP sensor Ø 51.8 x 76.94 x 34.9mm (Ø x L x W)</p>



FLIR Systems, Inc.
6769 Hollister Ave.
Goleta, CA 93117
USA
PH: +1 805.964.9797
PH: +1 877.773.3547 (Sales)
PH: +1 888.747.3547 (Support)
FX: +1 805.685.2711
www.flir.com/security

Corporate Headquarters
FLIR Systems, Inc.
27700 SW Parkway Ave.
Wilsonville, OR 97070
USA
PH: +1 503.498.3547
FX: +1 503.498.3153

Document:
CF-6308 Box IP Camera User and Installation Guide
Version: Ver. 1
Date: May 21, 2017
Language: en-US