

# Value IP Series Outdoor Network Camera

2-Megapixel 288 Series / 3-Megapixel 368 Series / 4-Megapixel 468 Series

---

*User's Manual*



**EBN288/368/468**



**EDN288M/368M/468M**



**EZN288M/368M/468M**



**EMN468**



**EMN468W**



**EZN288/368/468**



Copyright © EverFocus Electronics Corp.

Release Date: January, 2018



Copyright © 1995-2018 EverFocus Electronics Corp.

### **Disclaimer**

All the images including product pictures or screen shots in this document are for example only. The images may vary depending on the product and software version. Information contained in this document is subject to change without notice.

### **Copyright**

All rights reserved. No part of the contents of this manual may be reproduced or transmitted in any form or by any means without written permission of the EverFocus Electronics Corporation.

EverFocus

12F-1, No.79, Sec. 1, Shin-Tai Wu Road,

Hsi-Chih, New Taipei City, Taiwan

TEL: +886 2 2698 2334

FAX: +886 2 2698 3943

[www.everfocus.com.tw](http://www.everfocus.com.tw)

January, 2018

## About this document

All the safety and operating instructions should be read and followed before the unit is operated. This manual should be retained for future reference. The information in this manual was current when published. The manufacturer reserves the right to revise and improve its products. All specifications are therefore subject to change without notice.

## Regulatory Notices

### FCC Notice "Declaration of Conformity Information"

This equipment has been tested and found to comply with the limits for a Class A digital device, pursuant to part 15 of the FCC Rules. These limits are designed to provide reasonable protection against harmful interference in a residential installation. This equipment generates, uses and can radiate radio frequency energy and, if not installed and used in accordance with the instructions, may cause harmful interference to radio communications. However, there is no guarantee that interference will not occur in a particular installation. If this equipment does cause harmful interference to radio or television reception, which can be determined by turning the equipment off and on, the user is encouraged to try to correct the interference by one or more of the following measures:

- Reorient or relocate the receiving antenna.
- Increase the separation between the equipment and receiver.
- Connect the equipment into an outlet on a circuit different from that to which the receiver is connected.
- Consult the dealer or an experienced radio/TV technician for help.

Warning: Changes or modifications made to this equipment, not expressly approved by EverFocus or parties authorized by EverFocus could void the user's authority to operate the equipment.

This device complies with part 15 of the FCC Rules. Operation is subject to the following two conditions:

- (1) This device may not cause harmful interference, and
- (2) This device must accept any interference received, including interference that may cause undesired operation.

EverFocus Electronics Corp.

12F-1, No. 79, Sec. 1, Shin-Tai Wu Rd.,

Hsi-Chi, New Taipei City, Taiwan

Value IP Series camera complies with CE and FCC.

# Precautions

## **Do not install the camera near electric or magnetic fields.**

Install the camera away from TV/radio transmitters, magnets, electric motors, transformers and audio speakers since the electromagnetic fields generated from these devices may distort the video image or otherwise interfere with camera operation.

## **Never disassemble the camera beyond the recommendations in this manual nor introduce materials other than those recommended herein.**

Improper disassembly or introduction of corrosive materials may result in equipment failure or other damage.

## **Try to avoid facing the camera toward the sun.**

In some circumstances, direct sunlight may cause permanent damage to the sensor and/or internal circuits, as well as creating unbalanced illumination beyond the capability of the camera to compensate.

### **1. Keep the power cord away from water and other liquids and never touch the power cord with wet hands.**

Touching a wet power cord with your hands or touching the power cord with wet hands may result in electric shock.

### **2. Never install the camera in areas exposed to oil, gas or solvents.**

Oil, gas or solvents may result in equipment failure, electric shock or, in extreme cases, fire.

### **3. Cleaning**

For cameras with interchangeable lenses, do not touch the surface of the sensor directly with the hands. Use lens tissue or a cotton tipped applicator and ethanol to clean the sensor and the camera lens. Use a damp soft cloth to remove any dirt from the camera body. Please do not use complex solvents, corrosive or abrasive agents for cleaning of any part of the camera.

### **4. Do not operate the camera beyond the specified temperature, humidity or power source ratings.**

Use the camera at temperatures within  $-10^{\circ}\text{C} \sim 50^{\circ}\text{C}$  /  $14^{\circ}\text{F} \sim 122^{\circ}\text{F}$ , and humidity between 0% and 90%; this device is not rated as submersible. The input power source is 12VDC / PoE. Be sure to connect the proper + / - polarity and voltage, as incorrect polarity or too high a voltage will likely cause the camera to fail, and such damage is not covered by the warranty. The use of properly fused or Class 3 power limited type supplies is highly recommended.

### **5. Mounting**

Use care in selecting a solid mounting surface which will support the weight of the camera plus any wind, snow, ice or other loading, and securely attach the camera to the mounting surface using screws and anchors which will properly support the camera. If necessary (e.g. when mounting to drop ceilings) use a safety wire to provide additional support for the camera.

# CONTENTS

<b>1.</b>	<b>Introduction.....</b>	<b>1</b>
<b>2.</b>	<b>Physical Description .....</b>	<b>3</b>
2.1.	Dimensions .....	5
<b>3.</b>	<b>FEATURES .....</b>	<b>7</b>
<b>4.</b>	<b>Installation.....</b>	<b>8</b>
4.1.	Packing List.....	8
4.2.	Optional Accessory .....	8
4.3.	Cables.....	9
4.4.	Basic Installation .....	11
4.4.1	Mounting and Wiring.....	11
4.4.2	Inserting a Micro SD Card .....	22
<b>5.</b>	<b>Accessing the Camera .....</b>	<b>25</b>
5.1.	Checking the Dynamic IP Address .....	25
5.2.	Settings for Microsoft Internet Explorer.....	27
5.3.	Connecting the Camera to the Network.....	28
5.4.	Live View Window .....	30
<b>6.</b>	<b>Quick Setup Panel .....</b>	<b>32</b>
6.1	Streaming.....	32
6.2	Camera.....	33
6.3	Lens CTRL.....	33
6.4	Account.....	34
<b>7.</b>	<b>System .....</b>	<b>34</b>
7.1.	System Settings.....	35
7.1.1	Network .....	35
7.1.1.1	IP Settings .....	35
7.1.1.2	Multicast Settings .....	37
7.1.1.3	DDNS Settings.....	38
7.1.2	Date / Time .....	40
7.1.2.1	Date/Time Settings.....	40
7.1.2.2	NTP Settings.....	40
7.1.2.3	DST Settings.....	41
7.1.3	Schedule Record .....	42
7.1.4	Storage .....	43

7.1.5	Display and Overlay.....	44
7.1.6	System Maintenance.....	45
7.1.5.1	Upgrade Firmware.....	45
7.1.5.2	Auto Reboot .....	45
7.1.5.3	Restore.....	46
7.1.7	System Information.....	48
7.1.8	User.....	49
7.1.9	Serial Communication.....	51
7.1.10	Local Settings .....	52
7.2.	Camera Settings.....	53
7.2.1	Streaming and Audio .....	53
7.2.1.1	Audio Settings.....	53
7.2.1.2	Stream Settings.....	54
7.2.1.3	Privacy Mask Settings.....	55
7.2.2	Camera.....	56
7.2.3	Image .....	59
7.3.	Event Settings .....	60
7.3.1	Event .....	60
7.3.1.1	Motion Settings .....	60
7.3.1.2	Tamper Detection Settings .....	62
7.3.1.3	Alarm Input.....	63
7.3.1.4	Alarm Output.....	65
7.3.1.5	Exception Settings .....	66
7.3.2	Notification .....	67
7.3.2.1	Email Settings .....	67
7.4.	Search and Play.....	68
7.4.1	Playback .....	68
7.4.2	File.....	70
7.4.3	View Log.....	72
<b>8.</b>	<b>Upgrading Firmware Using IP Utility.....</b>	<b>73</b>
<b>9.</b>	<b>Specifications .....</b>	<b>75</b>
<b>10.</b>	<b>Troubleshooting.....</b>	<b>77</b>
<b>Appendix</b>	<b>.....</b>	<b>77</b>
A.	Enabling the Multicast Function.....	77
B.	RTSP URL Syntax .....	79
C.	Setting up Port Forwarding Function.....	80
D.	Setting up DDNS Function .....	82

## 1. Introduction

The Value IP 2-megapixel 288 / 3-megapixel 368 / 4-megapixel 468 series H.265 Outdoor IP camera provides 30fps at 1920 x 1080 / 2048 x 1536 / 2592 x 1520 viewing resolution. The series supports dual streams from H.265 or H.264 video compression formats. In same resolution, the H.265 provides higher compression efficiency and lower bitrate comparing with H.264 codec, allowing more efficient bandwidth and data storage usage. The True Wide Dynamic Range (WDR) function on the other hand enables the IP camera to provide clear images even under back light circumstances where intensity of illumination can vary excessively.

Featured with a motorized zoom lens, EDN288M/368M/468M; EZN288M/368M/EZN468M can provide the desired field of view with superior video quality in precise focus. Equipped with a weather-proof (IP66) housing, the Value IP 288 / 368 / 468 series meets a wide variety of needs for outdoor surveillance. Except 12VDC power supply, the series also supports Power over Ethernet (IEEE 802.3af), which eliminates the need for power cables and thus reduce the installation costs.

The Value IP 288 / 368 / 468 series conforms to ONVIF for compatibility with other network video devices. You can also use EverFocus Mobile applications to remotely view the live views of the cameras through your iOS or android handheld devices; or use EverFocus CMS to remotely manage multiple IP devices connected on the network.

### Types of Models

The Value IP camera provides two types: **Standard type** and **Economic type**. The Standard type models provide full functionality; while the Economic type models provide basic functionality.

	Standard Type	Economic Type
<b>Supported Models</b>	EBN288/368/468 EDN288M/368M/468M EZN288/368/468 EZN288M/368M/468M	EBN288/368/468 EDN288M/368M/468M EMN468/468W EZN288/368/468 EZN288M/368M/468M
<b>Functions</b>		
<b>Audio In/Out</b>	Supported	-
<b>Alarm In/Out</b>	Supported	-
<b>RS-485</b>	Reserved	-

### Models Comparison

Model Name	Lens	Max. Resolution	Storage	IR / WDR	IP66 / IK10
EBN288	3.6mm Fixed Lens	1920 x 1080	-	Yes / T-WDR	Yes / -
EBN368		2048 x 1536		Yes / T-WDR	
EBN468		2592 x 1520		Yes / D-WDR	
EDN288M	2.8-12mm Motorized Lens	1920 x 1080	Micro SD / SDHC / SDXC (Max. 128GB)	Yes / T-WDR	Yes / Yes
EDN368M		2048 x 1536		Yes / T-WDR	
EDN468M		2592 x 1520		Yes / D-WDR	
<b>EMN468</b>	3.6mm Fixed Lens	2592 x 1520	Micro SD / SDHC / SDXC (Max. 128GB)	Yes / D-WDR	Yes / -
<b>EMN468W</b>	2.2mm Fixed Lens			- / D-WDR	
EZN288	3.6mm Fixed Lens	1920 x 1080	Micro SD / SDHC / SDXC (Max. 128GB)	Yes / T-WDR	Yes / -
EZN368		2048 x 1536		Yes / T-WDR	
EZN468		2592 x 1520		Yes / D-WDR	
EZN288M	2.8-12mm Motorized Lens	1920 x 1080	Micro SD / SDHC / SDXC (Max. 128GB)	Yes / T-WDR	Yes / -
EZN368M		2048 x 1536		Yes / T-WDR	
EZN468M		2592 x 1520		Yes / D-WDR	

### System Requirement

Before installing, please check that your computer meets the following system requirements.

- Operating System: Microsoft Windows XP / Vista (32-bit) / 7 (32-bit)
- Microsoft Internet Explorer 11 or later, Chrome (Windows version 44 and earlier), Firefox version 50 and earlier, EverFocus Browser

**Note:** For using the Internet Explorer, some settings are required. Please refer to [5.2 Settings for Microsoft Internet Explorer](#).



## 2. Physical Description

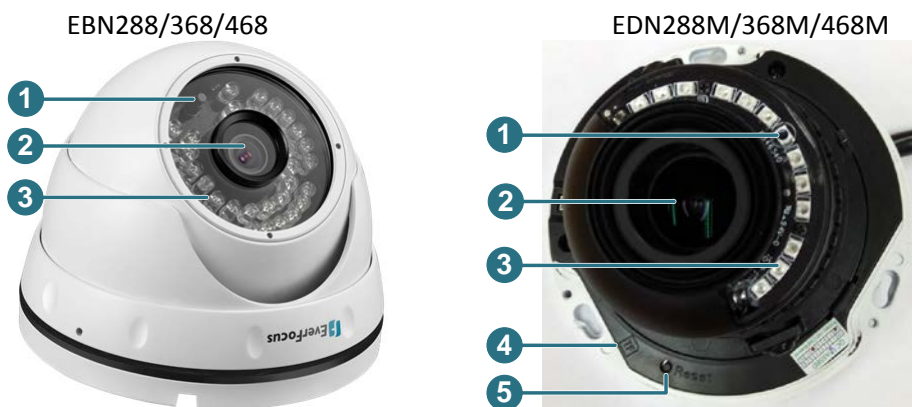

No.	Item Name	Descriptions
1	<b>Light Sensor</b>	Detects lights.
2	<b>Lens</b>	Lens.
3	<b>IR LEDs</b>	IR LEDs for infrared illumination in night vision applications.
4	<b>Micro SD/SDHC/SDXC Slot</b>	Insert a micro SD/SDHC/SDXC card. Please go to the web page of the IP camera to see the latest Storage Compatibility List. <a href="http://www.everfocus.com.tw">http://www.everfocus.com.tw</a>
5	<b>Reset Button</b>	Press the button to restore the camera to factory default.

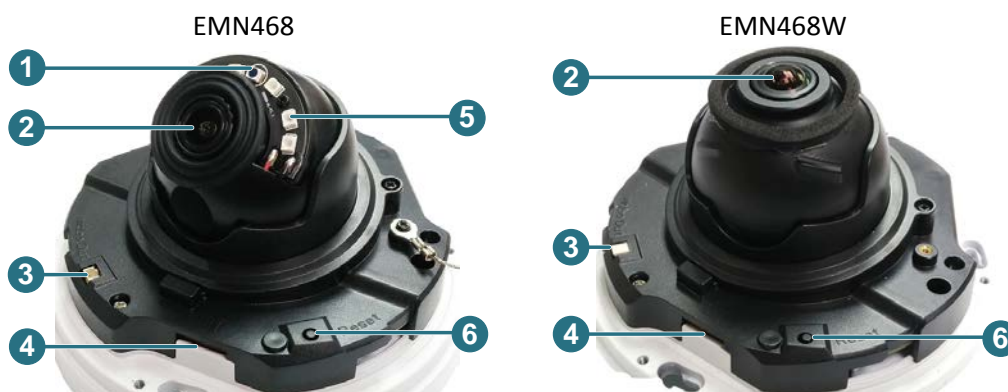

No.	Item Name	Descriptions
1	<b>Light Sensor</b>	Detects lights.
2	<b>Lens</b>	Lens.
3	<b>Video Test Output</b>	Connects to a monitor.
4	<b>Micro SD/SDHC/SDXC Slot</b>	Insert a micro SD/SDHC/SDXC card. Please go to the web page of the IP camera to see the latest Storage Compatibility List. <a href="http://www.everfocus.com.tw">http://www.everfocus.com.tw</a>
5	<b>IR LEDs</b>	IR LEDs for infrared illumination in night vision applications.
6	<b>Reset Button</b>	Press the button to restore the camera to factory default.

EZN288/368/468

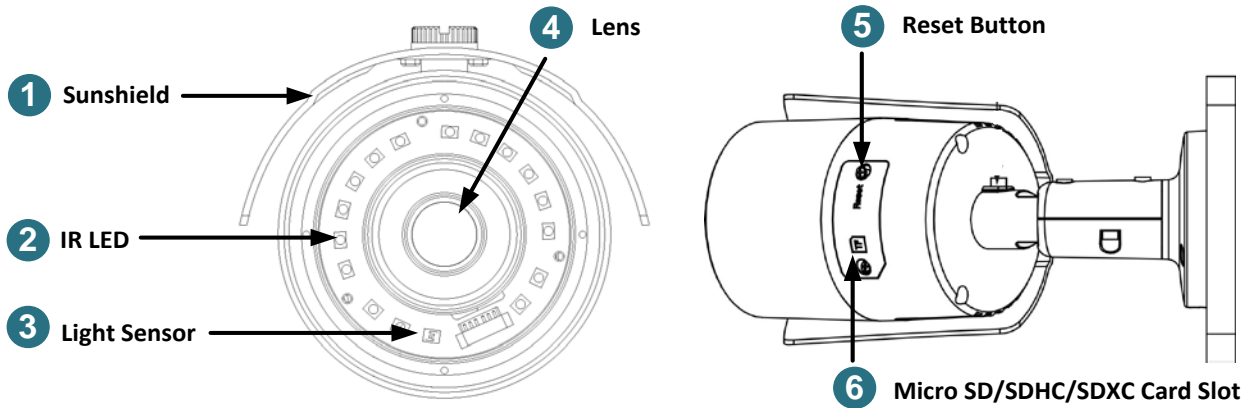

No.	Item Name	Descriptions
1	Sunshield	Protect the camera from the direct rays of the sun.
2	IR LEDs	IR LEDs for infrared illumination in night vision applications.
3	Light Sensor	Detects lights.
4	Lens	Fixed lens.
5	Reset Button	Press the button to restore the camera to factory default.
6	Micro SD/SDHC/SDXC Slot	Insert a micro SD/SDHC/SDXC card. Please go to the web page of the IP camera to see the latest Storage Compatibility List. <a href="http://www.everfocus.com.tw">http://www.everfocus.com.tw</a>

EZN288M/368M/468M

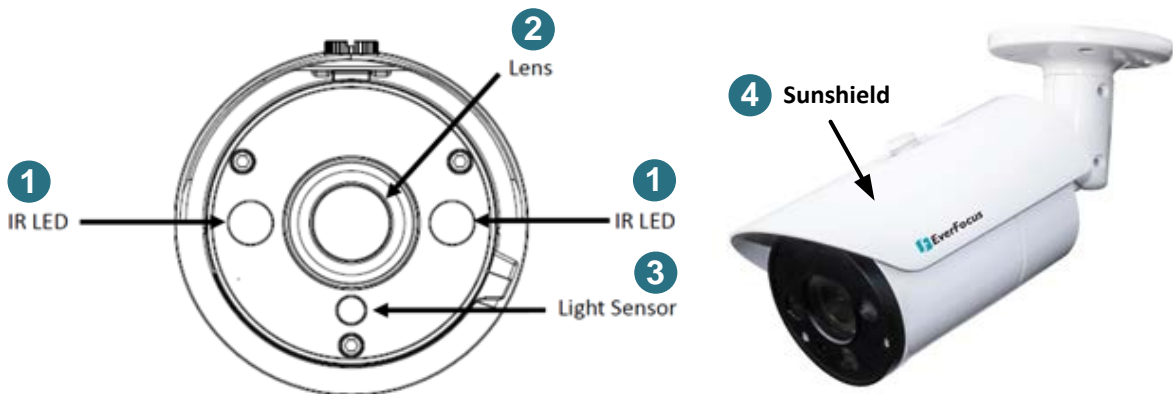

No.	Item Name	Descriptions
1	IR LEDs	IR LEDs for infrared illumination in night vision applications.
2	Lens	Motorized lens.
3	Light Sensor	Detects lights.
4	Sunshield	Protect the camera from the direct rays of the sun.

**2.1. Dimensions**

**EBN288/368/468**

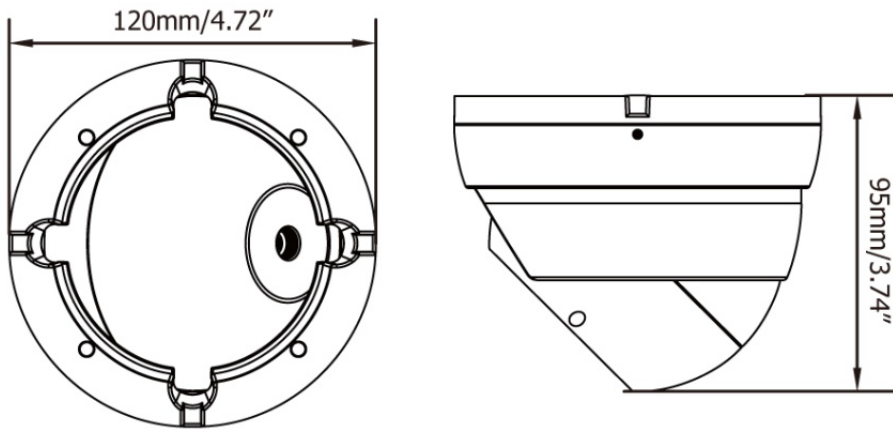

**EDN288M/368M/468M**

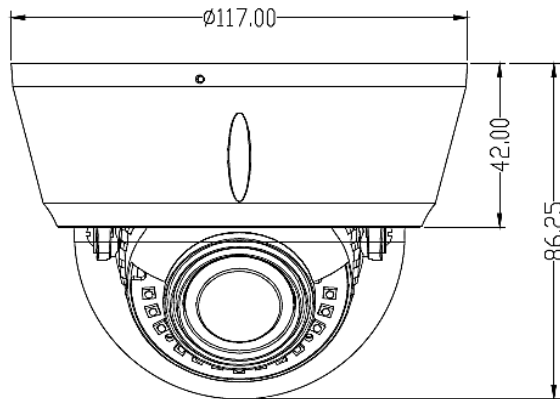

**EMN468/468W**

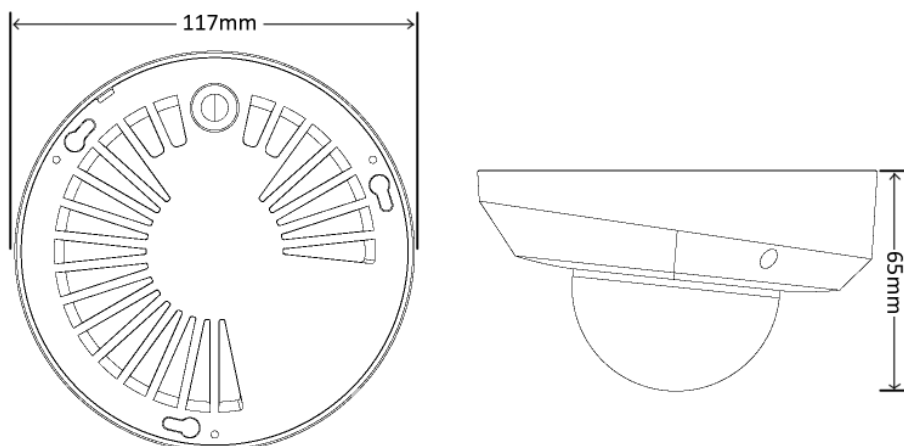

**EZN288/368/468**

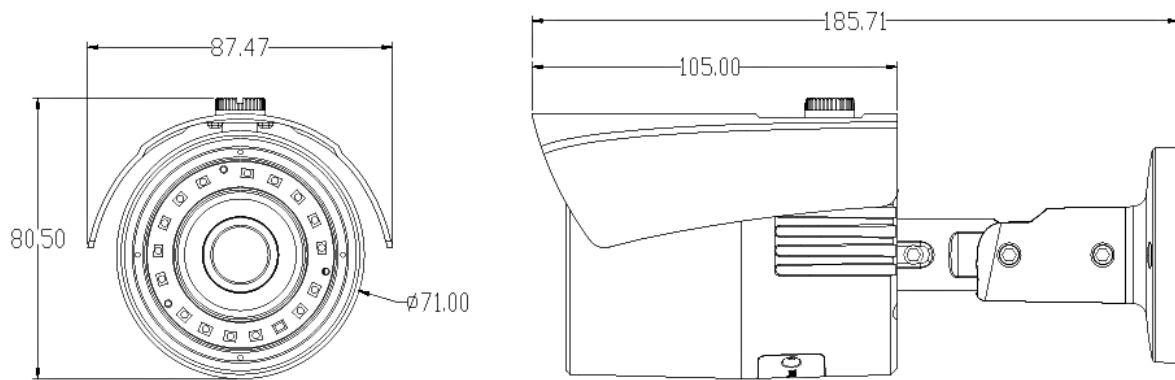

**EZN288M/368M/468M**

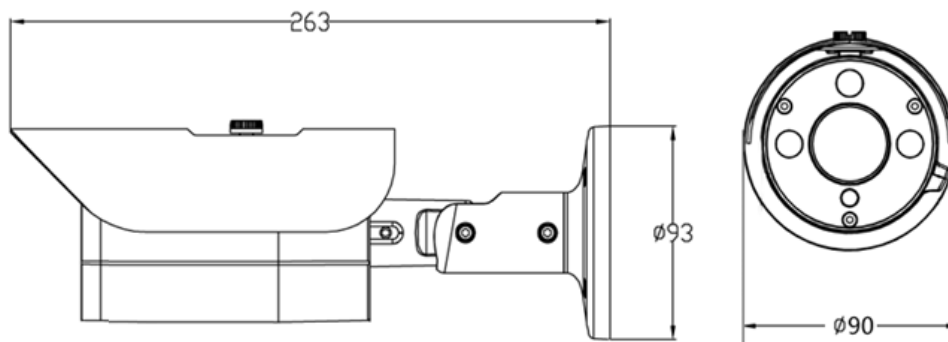

### 3. Features

- SONY Progressive Scan CMOS sensor
- Various lens selection:
  - Astounding image quality from the 3.6mm lens (**EBN288/368/468; EMN468; EZN288/368/468**)
  - Motorized 2.8-12mm lens to capture the desired field of view (**EDN288M/368M/468M; EZN288M/368M/468M**)
  - Wide angle of view with 2.2mm lens (FOV: Diagonal 165°) (**EMN468W**)
- Supports True Wide Dynamic Range (120dB) (**only for 2MP/3MP models**)
- Provides True Day/Night functionality with automatic IR filter operation
- Supports IR LEDs for night vision:
  - Extended IR range up to 30m / 100ft (Depending on scene IR reflectivity) (**for EBN/EDN/EZN series models**)
  - Extended IR range up to 10m / 33ft (Depending on scene IR reflectivity) (**for EMN468**)
- Multi-streaming from H.265 / H.264
- 1080p real time recording
- Weather proof IP66-rated
- The flexible angle viewing with 3-Axis rotation design (**EMN series models support 2-Axis**)
- Supports Motion Detection & Email Notification
- Supports mobile application for live monitoring - MobileFocus Apps (iOS & Android)
- Supports Power over Ethernet / 12VDC
- Ideal for low light and nighttime visibility
- Supports EverFocus Genie XMS CMS
- ONVIF profile S compliant
- Supports Micro SD card (**EBN series models are not supported**)
- Supports two-way audio\*
- Supports Alarm I/O\*
- Supports RS-485 (reserved)\*

\* Economic models do not include the feature

## 4. Installation

### 4.1. Packing List

Please check that there is no missing item in the package before installing.

No	Item Name	EBN288/ 368/468	EDN288M/ 368M/468M	EMN468/ 468W	EZN288/ 368/468	EZN288M/ 368M/468M
1	<b>Camera</b>	x 1	x 1	x 1	x 1	x 1
2	<b>MAC Address Sticker</b>	x 2	x 2	x 2	x 2	x 2
3	<b>Screw Anchor</b> (in conjunction with Screw)	x 4	x 3	x 3	x 3	x 4
4	<b>Screw</b>	x 4	x 3	x 3	x 3	x 4
5	<b>Hexagon Wrench</b> (for adjusting camera position)	x 1	-	x 1	x 1	x 1
6	<b>Cable Gland Kit</b> (connect to the LAN/PoE cable for waterproofing)	x 1	x 1	x 1	x 1	x 1
7	<b>Set Screw</b>	x 3	-	-	-	-
8	<b>Power Pigtail Cable</b>	x 1	x 1	x 1	x 1	x 1
9	<b>Accessories Instruction</b> (for installation of Set Screw)	x 1	-	-	-	-
10	<b>Software CD</b>	x 1	x 1	x 1	x 1	x 1
11	<b>Quick Installation Guide</b>	x 1	x 1	x 1	x 1	x 1
12	<b>Sticker</b> (Mounting Template)	x 1	x 1	x 1	x 1	x 1
13	<b>Gasket</b>	-	-	x 1 (EMN468W only)	-	-

#### Note:

- Equipment configurations and supplied accessories vary by country. Please consult your local EverFocus office or agents for more information. Please also keep the shipping carton for possible future use.
- Contact the shipper if any items appear to have been damaged in the shipping process.

### 4.2. Optional Accessory

You can go to the product page on EverFocus' website to check the related optional accessories.

[www.everfocus.com.tw](http://www.everfocus.com.tw)

**4.3. Cables**

For **Standard models**, the cables provide connections for Network, BNC output, power, audio input / output, RS-485 (reserved) and alarm inputs / output. A Reset Button is also provided. Note that the audio-in / out cable features a line 3.5mm jack (TRS). Be sure to prepare microphones / speakers with TRS connector (see TRS Connector image below). Also, microphones / speakers with a (built-in) amplifier and external power supply are required.

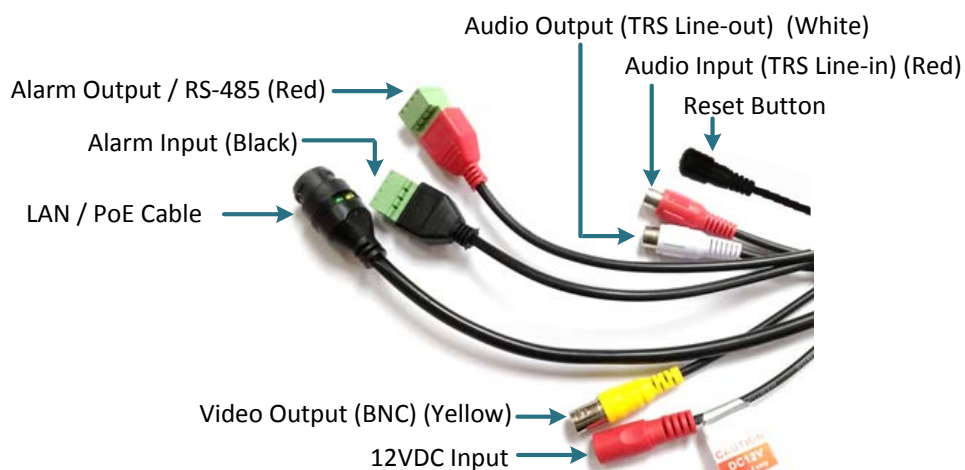

Cable	EBN288/ 368/468	EDN288M/ 368M/468M	EMN468/ 468W	EZN288/ 368/468	EZN288M/ 368M/468M
<b>Alarm In (with Terminal Block)</b>	Yes	Yes	-	Yes	Yes
<b>Alarm Out / RS-485 (reserved) (with Terminal Block)</b>	Yes	Yes	-	Yes	Yes
<b>Audio In (Red)</b>	Yes	Yes	-	Yes	Yes
<b>Audio Out (White)</b>	Yes	Yes	-	Yes	Yes
<b>Video Out (BNC)</b>	Yes	Yes	-	Yes	Yes
<b>LAN/PoE</b>	Yes	Yes	Yes	Yes	Yes
<b>12VDC</b>	Yes	Yes	Yes	Yes	Yes
<b>Reset Button (with a dust-proof cap)</b>	Yes	-	-	-	Yes

For **Economic models**, the cables provide connections for Network, power and Reset Button.



**Cables of Economic Models**

Model	LAN/PoE	12VDC	Reset Button
<b>EBN288/368/468</b>	Yes	Yes	Yes (with a dust-proof cap)
<b>EDN288M/368M/468M</b>	Yes	Yes	-
<b>EMN468/468W</b>	Yes	Yes	-
<b>EZN288/368/468</b>	Yes	Yes	-
<b>EZN288M/368M/468M</b>	Yes	Yes	Yes (with a dust-proof cap)

**Audio Function**

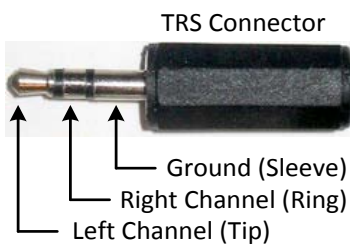

To activate the Audio function, the **Complex Stream** must be selected. See **Stream** in 7.2.1.2 Streaming Settings.

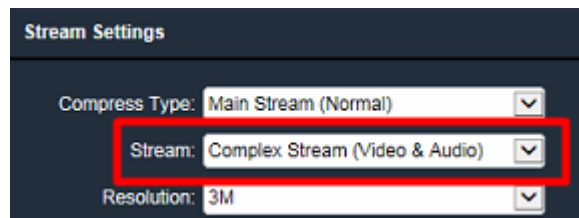

**Pin Assignment**

Alarm Output / RS-485 (reserved)		
	Alarm Output	COM (-)
		NO (+)
	RS-485 (reserved)	B (+)
		A (-)

Alarm Input		
	Alarm In 1	GND (-)
		Alarm In (+)
	Alarm In 2	Alarm In (+)
		GND (-)

**Reset Button**

**1. Reboot the camera:**

When the camera is powered up, press the **Reset Button** will reboot the camera.

**2. Restore the camera:**

Keep the **Reset Button** pressed, at the same time unplug the camera power then plug it back again will return camera settings to the factory default values.



**4.4. Basic Installation**

**4.4.1. Mounting and Wiring**

**EBN288/368/468**

1. Before screwing the camera to the wall, stick the **Sticker** on the wall / ceiling to mark the position for installation. Drill four holes on the wall / ceiling according to the supplied **Sticker** and push the supplied four **Screw Anchors** into the four holes on the wall / ceiling. Drill another hole in the middle of the **Sticker** if you wish to run the wires into the wall / ceiling.

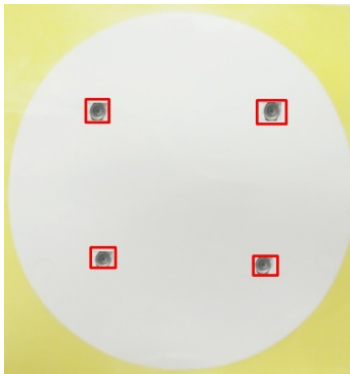

2. Twist the Outer Housing counterclockwise and then remove the Outer Housing from the camera base.



3. Place the camera base on the wall / ceiling and run the cable through the camera base first.
4. Tread the cables:
  - a. From the side cut of the camera base



- b. Through the wall / ceiling: run the cables through the hole on the wall / ceiling.

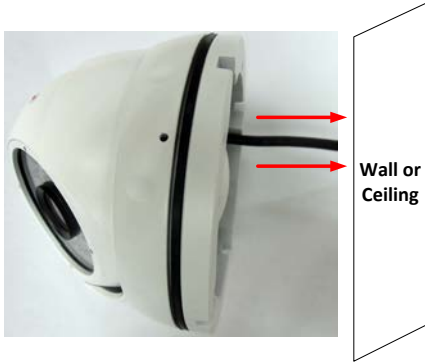

- 5. Use the supplied four **Screws** to screw the camera base to the ceiling / wall.



- 6. Adjust the camera angle and twist back the Outer Housing simultaneously.
- 7. Optionally screw back the **Set Screw** by using the supplied **Hexagon Wrench** to prevent uninstallation.



- 8. Connect the LAN / PoE cable to the camera.
  - a. Remove the **Screw Cap** from the **Cable Gland**.



- b. Insert a RJ-45 network cable (without the RJ-45 connector on the one end) through the **Cable Gland** and **Screw Cap**.



- c. Place the **Waterproof Ring** into the LAN / PoE cable. Connect the RJ-45 cable to the RJ-45 Connector Cable. Tightly screw the **Cable Gland** and **Screw Cap** to the RJ-45 Connector Cable.



9. Optionally connect the camera to the 12VDC power source using the supplied **Power Adapter Pigtail** or a power adapter.

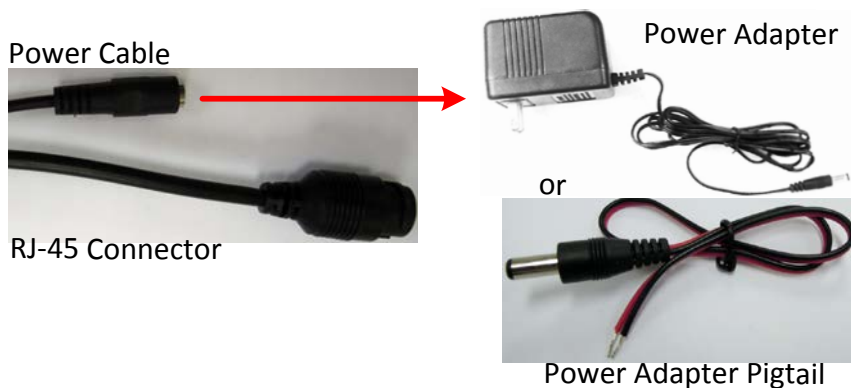

**EDN288M/368M/468M**

1. Before screwing the camera to the wall, stick the **Sticker** on the wall / ceiling to mark the position for installation. According to the supplied **Sticker**, drill three screw-depth holes on the wall / ceiling, and then drill a through-wall hole for wiring the camera cables. Push the supplied three **Screw Anchors** into the three holes on the wall / ceiling.

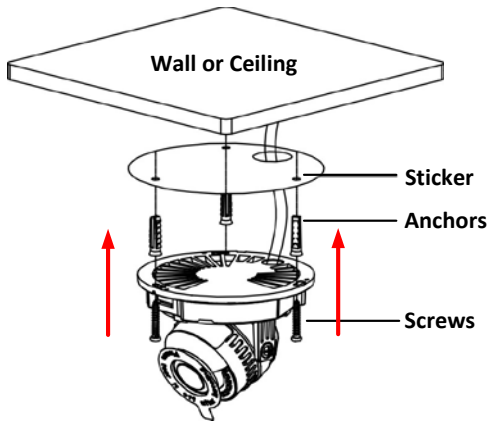

2. Unscrew the camera cover and screw the camera base to the ceiling / wall by using the supplied **Screws**.



3. Optionally insert the micro SDHC / SDXC card. Please refer to 4.4.2 *Inserting a micro SD Card*.

4. Connect the LAN / PoE cable to the camera.
  - a. Remove the **Screw Cap** from the **Cable Gland**.



- b. Insert a RJ-45 network cable (without the RJ-45 connector on the one end) through the **Cable Gland** and **Screw Cap**.



- c. Place the **Waterproof Ring** into the LAN / PoE cable. Connect the RJ-45 cable to the RJ-45 Connector Cable. Tightly screw the **Cable Gland** and **Screw Cap** to the RJ-45 Connector Cable.



5. Optionally connect the camera to the 12VDC power source using the supplied **Power Adapter Pigtail** or a power adapter.

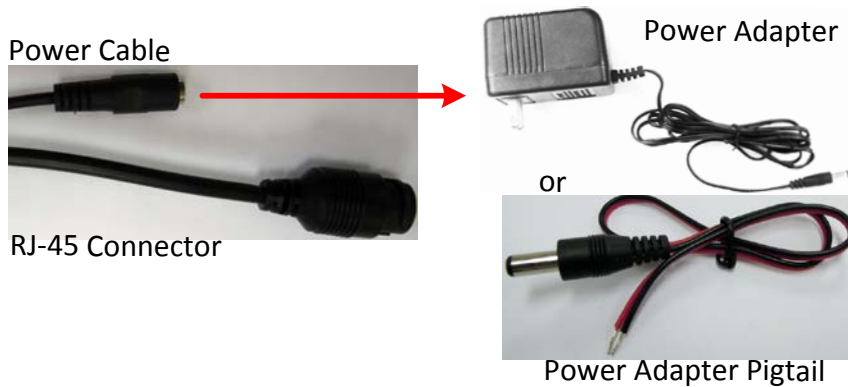

6. Access the camera live view. See 5. *Accessing the Camera*. Or using a video Test-Out cable to connect a monitor to the camera for setting image aim and focus.

7. To adjust camera angles.

**Pan Adjustment:** Simply turn left / right of the 3-Axis bracket by 75° to the desired position.

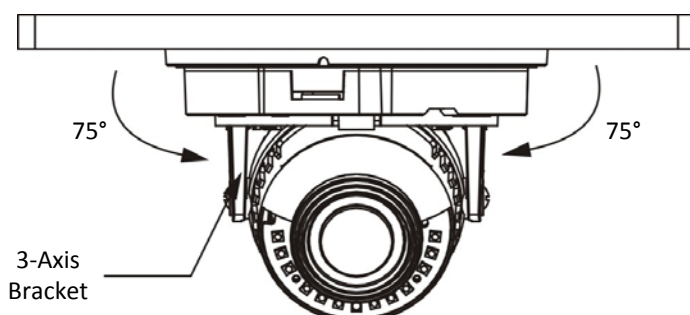

**Rotational Adjustment:** Loosen the rotate screw and rotate the camera left / right to the desired position, then tighten the rotate screw. Due to the internal connector design, it is recommended not to rotate the camera more than 30°.

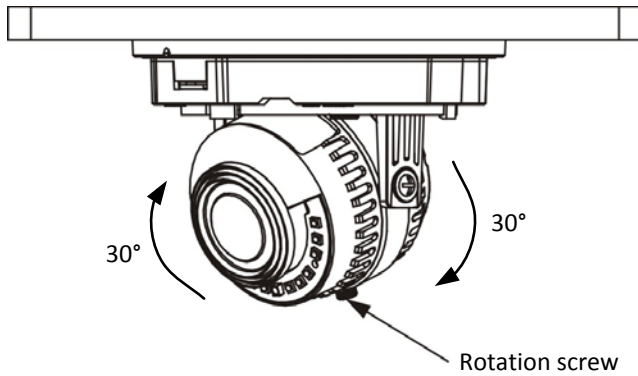

**Tilt Adjustment:** Loosen the two tilt screws and adjust the angle by 75° to the desired position, then tighten the tilt screw.

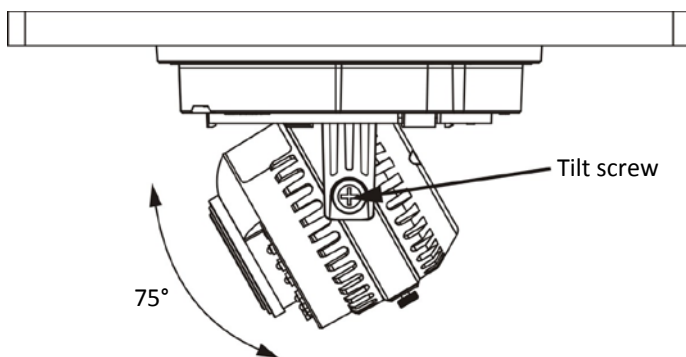

8. Secure the cover back to the camera.

**EMN468/468W**

1. Before screwing the camera onto the surface, stick the **Sticker** onto the surface to mark the position for installation. According to the supplied **Sticker**, drill three holes on the surface, and optionally drill a through-out hole for wiring the camera cables. Push the supplied three **Screw Anchors** into the three holes on the surface.
2. Unscrew the camera cover and screw the camera base to the surface by using the supplied **Screws**. Note that for EMN468W, place the supplied **Gasket** between the camera base and the surface; and then screw the camera base to the surface with the Gasket in the middle.



3. Connect the LAN / PoE cable to the camera.
  - a. Remove the **Screw Cap** from the **Cable Gland**.



- b. Insert a RJ-45 network cable (without the RJ-45 connector on the one end) through the **Cable Gland** and **Screw Cap**.



- c. Place the **Waterproof Ring** into the LAN / PoE cable. Connect the RJ-45 cable to the RJ-45 Connector Cable. Tightly screw the **Cable Gland** and **Screw Cap** to the RJ-45 Connector Cable.



- Optionally connect the camera to the 12VDC power source using the supplied **Power Adapter Pigtail** or a power adapter.

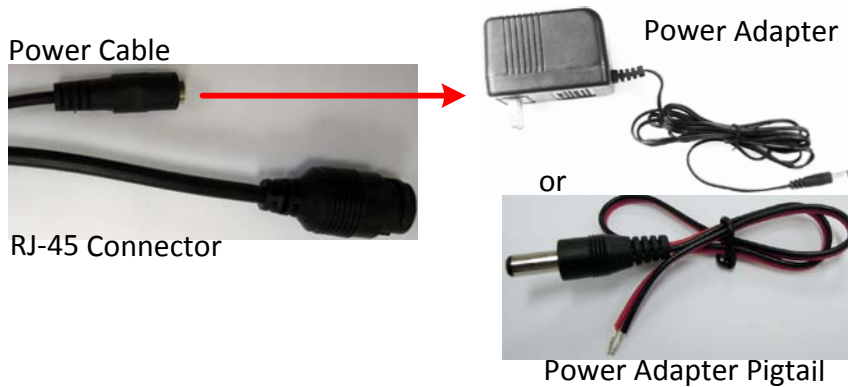

- Access the camera live view. See 5. *Accessing the Camera*. Or using a video Test-Out cable to connect a monitor to the Video Test Output on the camera for setting camera angles.



- To adjust camera angles.

**Pan Adjustment:** Simply turn left / right of the camera by 175° each side to the desired position.

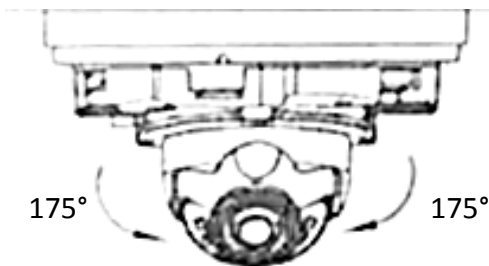

**Tilt Adjustment:** Adjust the tilt angle between 25° and 90°.

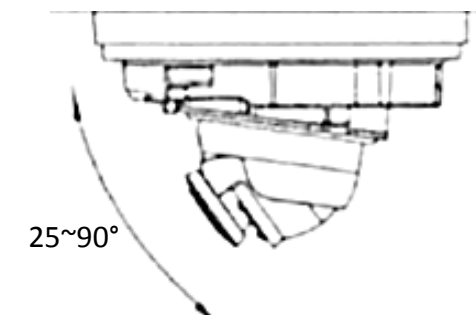

- Secure the cover back to the camera.



**EZN288/368/468 & EZN288M/368M/468M**

1. Before screwing the camera to the wall, stick the **Sticker** on the wall / ceiling to mark the screw position. Drill three (**EZN288/368/468**) or four (**EZN288M/368M/468M**) holes on the wall / ceiling according to the supplied **Sticker** and push the supplied **Anchors** into the holes on the wall / ceiling. Drill another hole in the middle of the **Sticker** if you wish to run the wires into the wall / ceiling.

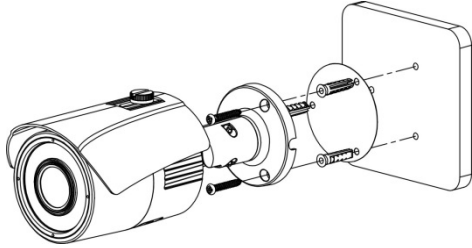

**EZN288/368/468**

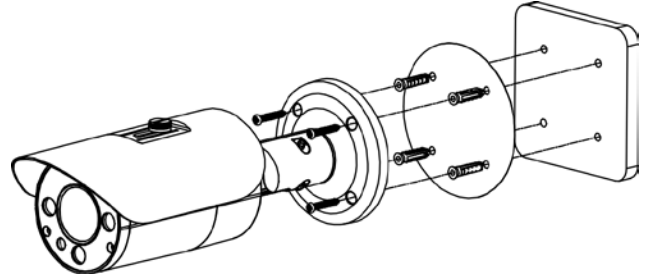

**EZN288M/368M/468M**

2. You can wire the cables from the side of the camera or through the wall.



Wire the cables from the side of the camera



Wire the cables through the wall

3. Place the camera's base against the anchoring surface so that the holes line up. Screw the camera to the wall / ceiling using the supplied **Screws**.
4. Optionally insert a micro SD / SDHC / SDXC card into the card slot. Please refer to 4.4.2 *Inserting a micro SD Card*.
5. Connect the LAN / PoE cable to the camera.
  - a. Remove the **Screw Cap** from the **Cable Gland**.



- b. Insert a **RJ-45 network cable** (without the RJ-45 connector on the one end) through the **Cable Gland** and **Screw Cap**.



- c. Place the **Waterproof Ring** into the LAN / PoE cable. Connect the RJ-45 cable to the RJ-45 Connector Cable. Tightly screw the **Cable Gland** and **Screw Cap** to the RJ-45 Connector Cable.



- 6. Optionally connect the camera to the 12VDC power source using the supplied **Power Adapter Pigtail** or a power adapter.

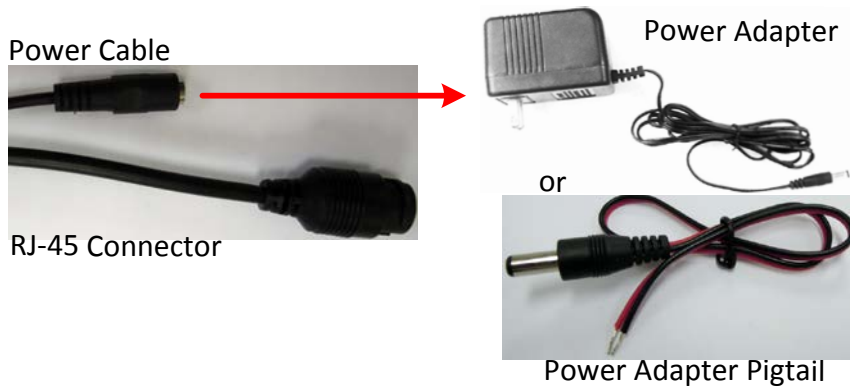

- 7. Access the camera live view. See 5. *Accessing the Camera*. Or connect a handheld test monitor to the CVBS wire on the Cable Assembly for adjusting viewing angles.

- 8. To adjust the camera angles:

**Pan Adjustment:** Loosen the Set Screw using the supplied **Hexagon Wrench**. Rotate the camera by 360° to the desired position and screw the Set Screw until it locks against the Camera Base.

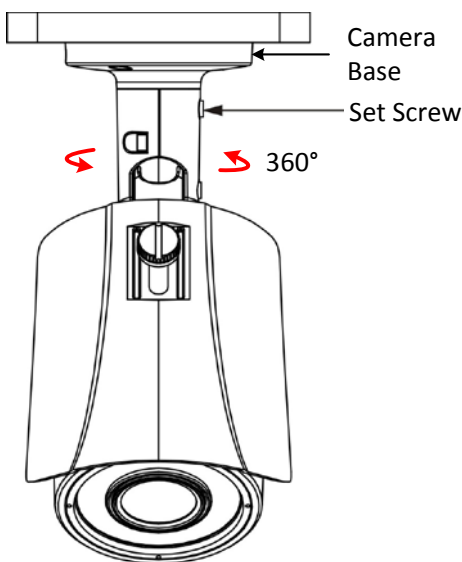

**EZN288/368/468**

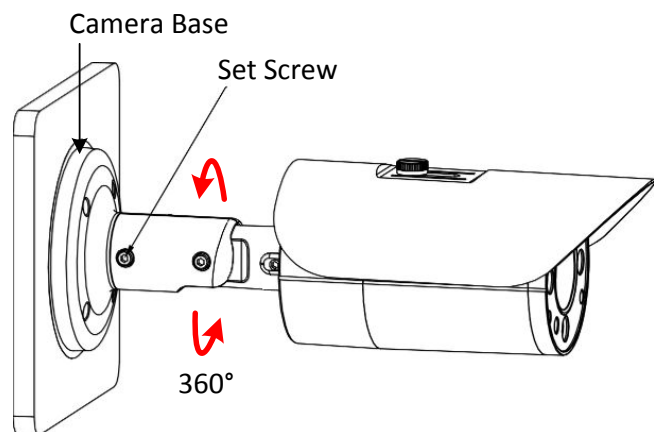

**EZN288M/368M/468M**

**Tilt Adjustment:** Loosen the Set Screw using the provided **Hexagon Wrench** and adjust the angle by 90°.

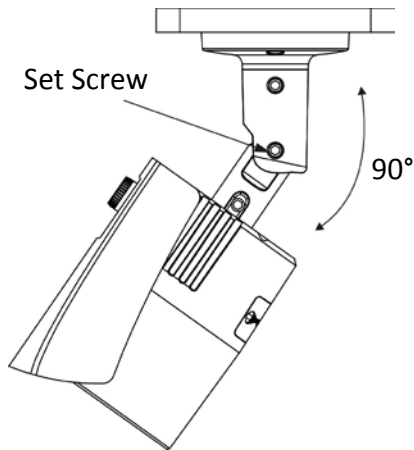

**EZN288/368/468**

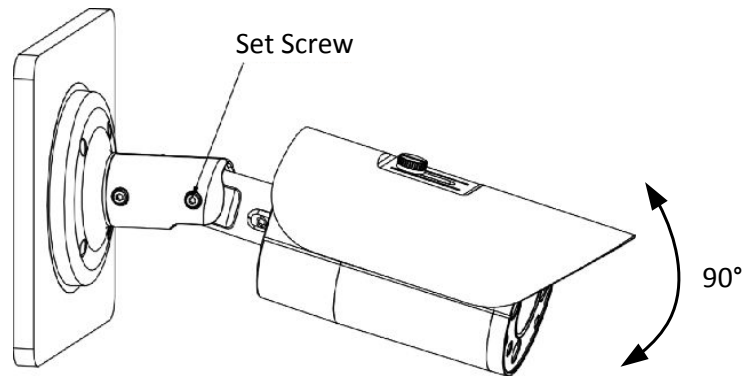

**EZN288M/368M/468M**

**Rotational Adjustment:** Loosen the Screw using the provided **Hexagon Wrench** and rotate the camera by 360°.

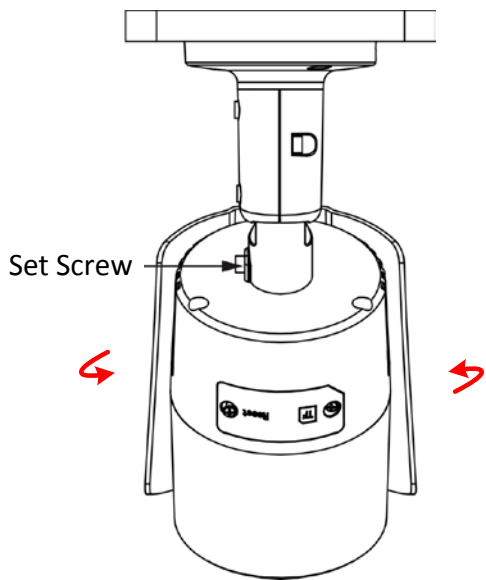

**EZN288/368/468**

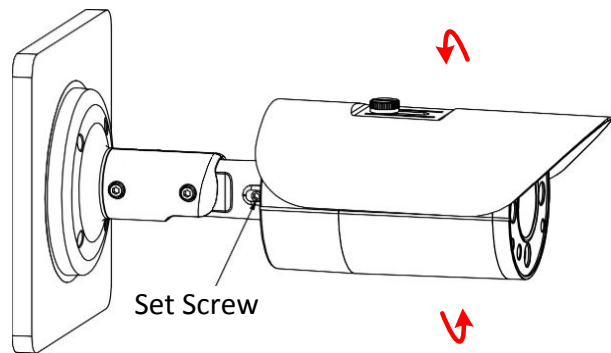

**EZN288M/368M/468M**

**Note:**

1. Before start operating the IP camera, please make sure the camera date and time are correct. To configure the camera date/time, go to System > Date/Time setting page on Web UI.
2. By default, the system will automatically adjust the IR LED strength according to the scene, so please avoid IR reflection when installing the camera to prevent out-of-focus at night.
3. Under **Auto** focus mode, if the camera does not focus after switching the Day/Night mode, it is recommended to switch the focus mode to **Manual** and adjust focus manually.

#### 4.4.2. Inserting a Micro SD Card

You can optionally insert a micro SD card to the card slot on the camera module for recording videos. Before inserting a micro SD card, make sure you turn off the camera first.

##### **EDN288M/368M/468M**

1. Unscrew and then remove the camera cover.



2. Insert a micro SD card into the card slot.



##### **EMN468/468W**

1. Unscrew and then remove the camera cover.
2. Insert a micro SD card into the card slot.



**EZN288/368/468**

1. Open the cover on the bottom of the camera by loosening the screws.

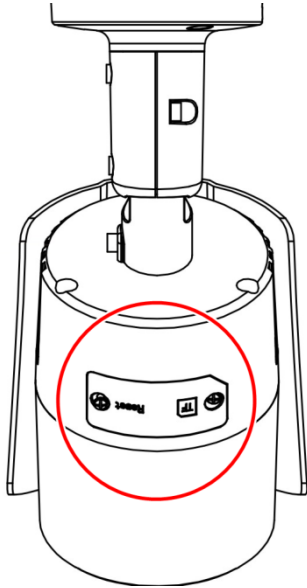

2. Insert a micro SD card into the card slot.

**EZN288M/368M/468M**

1. Loosen the two set screws on the bracket.

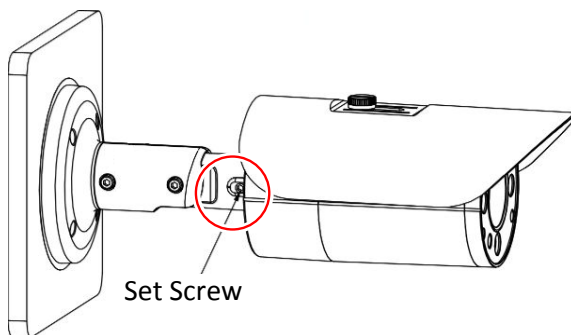

2. Loosen the three screws on the rear housing. Rotate and then remove the rear housing.

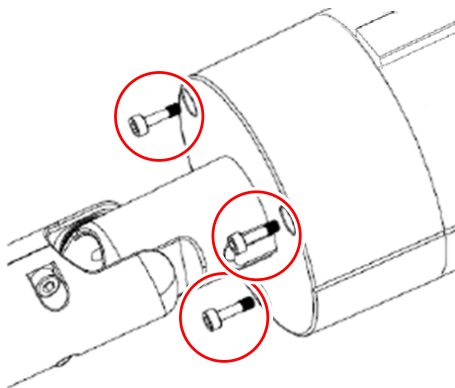

3. Loosen the four screws on the IPC board.



4. Insert a micro SD card into the card slot.



5. Put the water-proof ring on the groove that near the edge of the housing. Place the desiccant bag beside the IPC board.

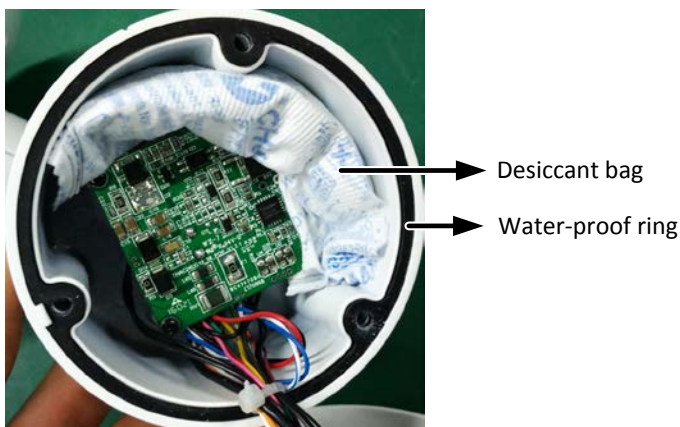

6. Screw back the IPC board, secure the rear housing back to the front housing and tighten the set screws on the bracket.

**Note:** Please make sure you wear the antistatic gloves or antistatic wrist strap when installing the Micro SD card to protect the device from damage.

**5. Accessing the Camera**

This section explains how to access the Web interface of the camera for configuration.

**5.1. Checking the Dynamic IP Address**

You can look up the IP address and access the Web interface of the IP camera using the **IP Utility (IPU)** program, which is included in the software CD. The IP Utility can also be downloaded from EverFocus' Website: [http://www.everfocus.com.tw/HQ/Support/DownloadCenter\\_p1.aspx](http://www.everfocus.com.tw/HQ/Support/DownloadCenter_p1.aspx) (Support > Download Center > Keyword Search: IP Utility). Please connect the IP camera on the same LAN of your computer.

1. Save **IP Utility Setup .exe**  in your computer. Double click the .exe file and follow the on-screen instructions to install the IP Utility.

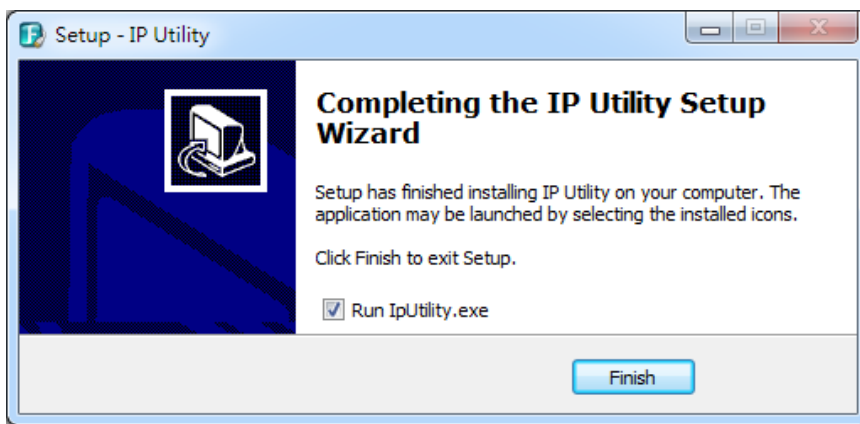

2. Click the **Finish** button, the IP Utility will be automatically launched to search the IP devices connected on the same LAN.

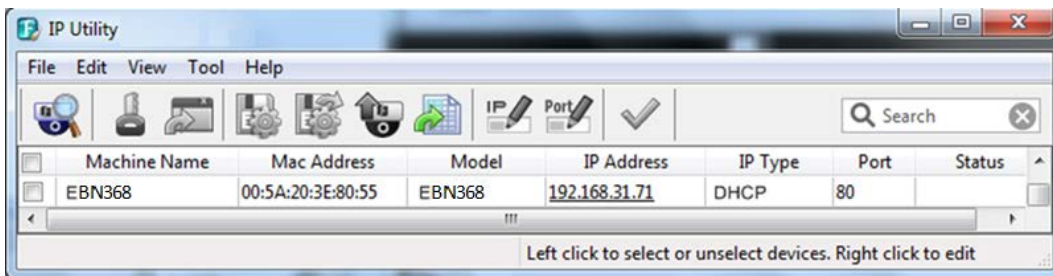

3. To access the Live View window, double click the IP address of the desired device, the login window pops up. Type the user ID and password to log in. By default, the user ID is **user1** and the password is **11111111**

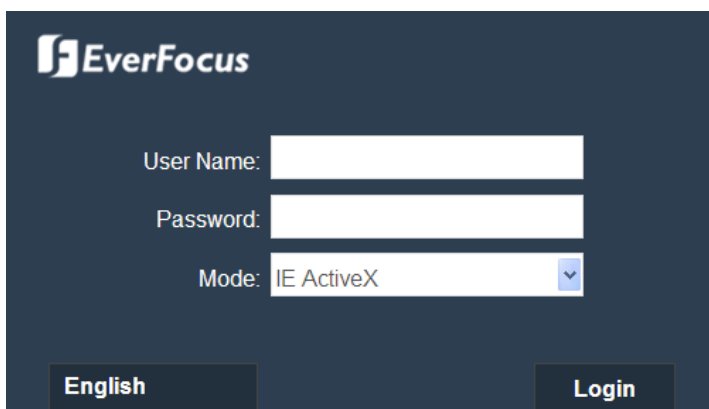

4. Click **Login**, the Live View window appears.

**Note:**

1. To enable Remote Live View, Firmware Upgrade and ActiveX Prompt on Internet Explorer, some settings have to be complete. Please refer to *5.2 Settings for Microsoft Internet Explorer*.
2. The default IP mode of the IP camera is DHCP. However, if there is no dynamic IP address assigned to the device, its IP will switch to **192.168.0.10**.

5. To optionally configure the Machine Name, IP Address, IP Type or Port Number using the IPU:
  - a. Log in the camera by checking the desired model and then click the **Log in**  icon. The Log in dialog box appears.



- b. Type the Username and Password. Click the **OK** button, the **Login** status displays.

	Machine Name	Model	IP Address	IP Type	Port	Status
<input checked="" type="checkbox"/>	EBN368	EBN368	192.168.32.135	DHCP	80	Login

**Note:**

1. The default user ID is **user1** and the default password is **11111111**.
2. If you select more than one camera that has the same user ID / password, you will be able to log in several cameras at once.

- c. Right click the column to configure the settings. Click the **Apply Changes**  button to apply and save the settings.

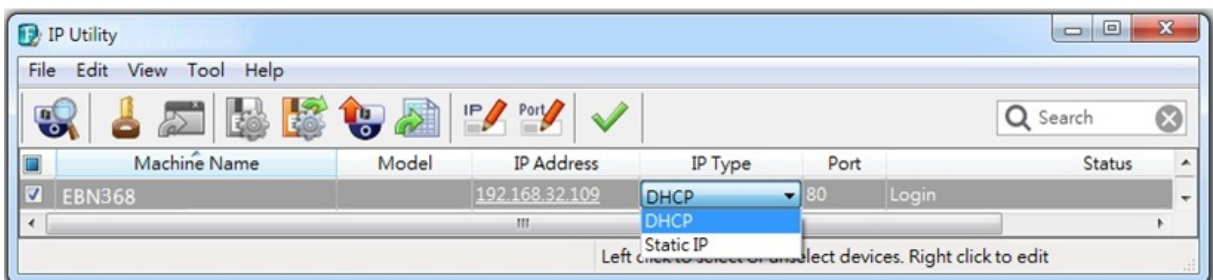



**5.2. Settings for Microsoft Internet Explorer**

If you have difficulties viewing live view or upgrading firmware, it is suggested to complete the following settings of your computer.

1. If your PC or laptop is running with Windows, it's required to run the browser as administrator when first entering the remote web page of the device. Go to **C:\Program Files (x86)\Internet Explorer**, right-click the browser and then click **Run as administrator**.

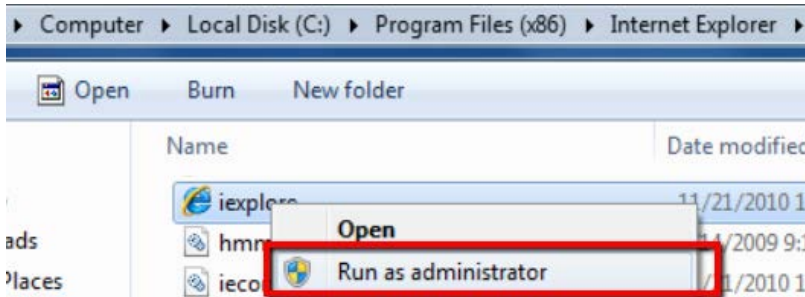

2. You may need to turn User Account Control off if you still can't see the Remote Live View. On the computer, click Start > Control Panel > System and Security > Action Center (click Change User Account Control Settings), the **User Account Control Settings** window appears. Adjust the slide bar to **Never Notify** and then click **OK**. Restart your computer if requested.

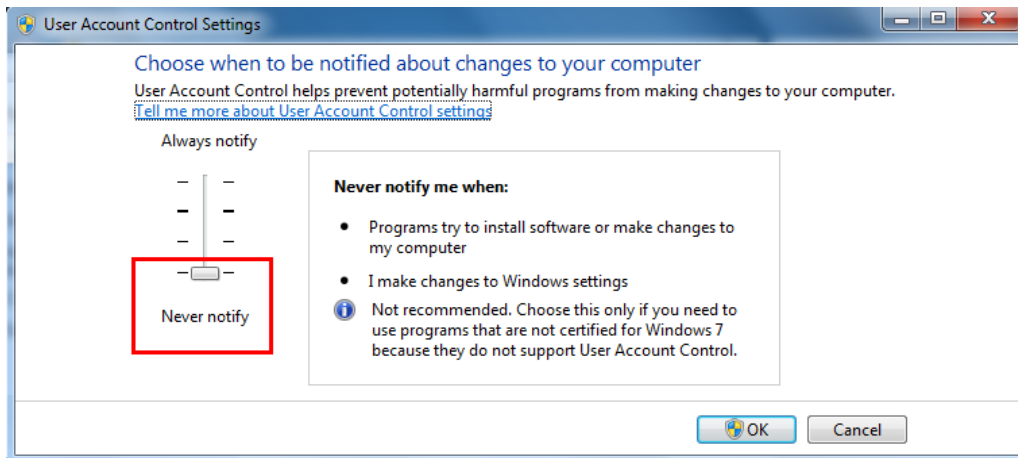

### 5.3. Connecting the Camera to the Network

There are three methods to connect the IP camera to the network: **Router or LAN Connection**, **Direct High-Speed Connection** and **One-to-One Connection**.

#### Router or LAN connection

This is the most common connection in which the IP camera is connected to a router and allows multiple users on and off site to see the IP camera on a LAN / WAN (Internet). The camera must be assigned an IP address that is compatible with its LAN. By setting up port forwarding on the router, you can remotely access the cameras from outside of the LAN via the Internet. To remotely access the Web interface of the IP camera, please refer to [7.1.1 Network \(DDNS Settings\)](#). To set up port forwarding, please refer to [Appendix D. Setting up Port Forwarding Function](#).

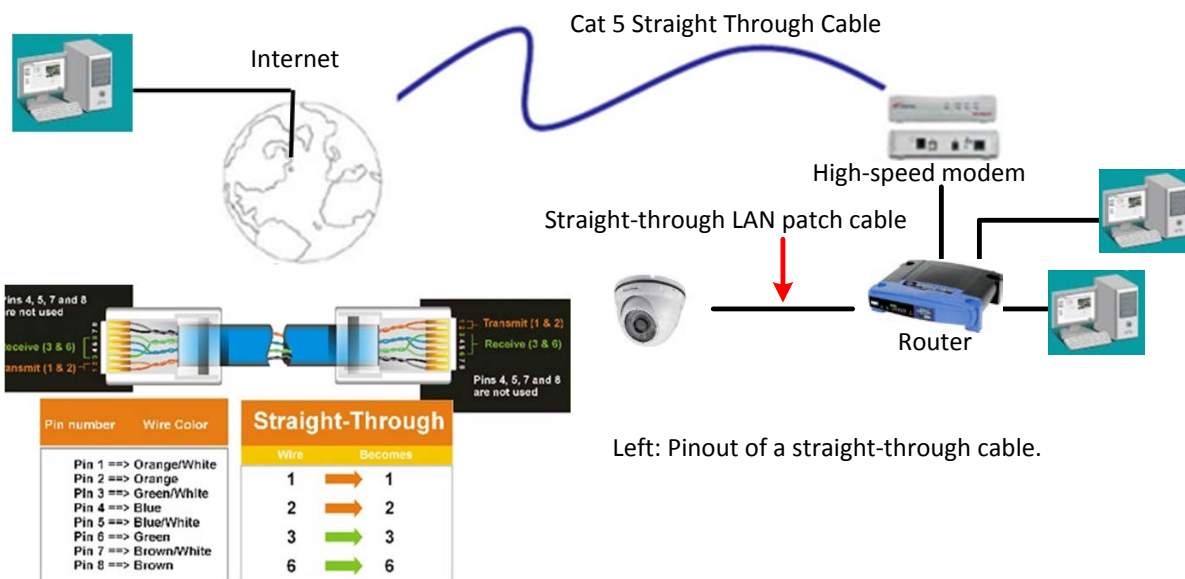

**Direct High-Speed Connection**

In a Direct High-Speed Connection, the camera connects directly to a modem without the need for a router. You need to set the static or dynamic WAN IP address assigned by your ISP (Internet Service Provider) in the camera’s configuration web pages. To access the camera, just type “http://xxx.xxx.xxx.xxx”, where xxx.xxx.xxx.xxx is the IP address given by your ISP. If you have a dynamic IP address, this connection may require that you use DDNS for a reliable connection. Please refer to [Appendix E. Setting up DDNS Function](#).



**One-to-One Connection (Directly from PC to IP Camera)**

You can connect directly without using a switch, router or modem. However, only the PC connected to the camera will be able to view the IP camera. You will also have to manually assign a compatible IP address to both the computer and the IP camera. Unless the PC has another network connection, the IP camera will be the only network device visible to the PC. See the diagram below:

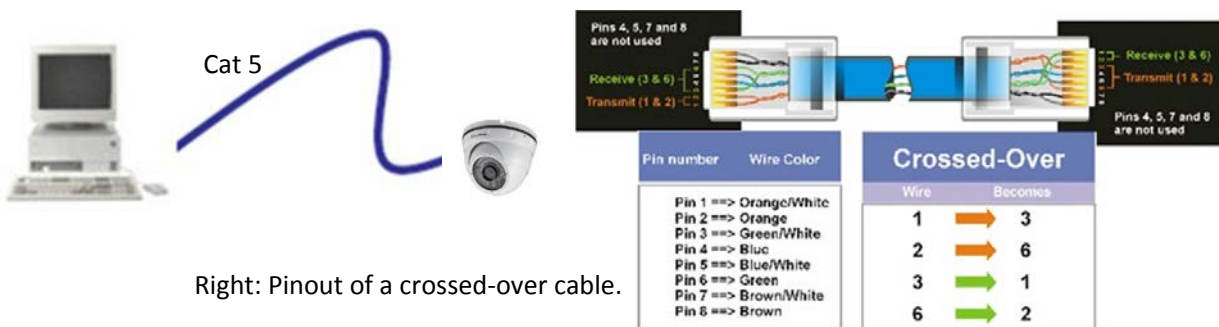

5.4. Live View Window

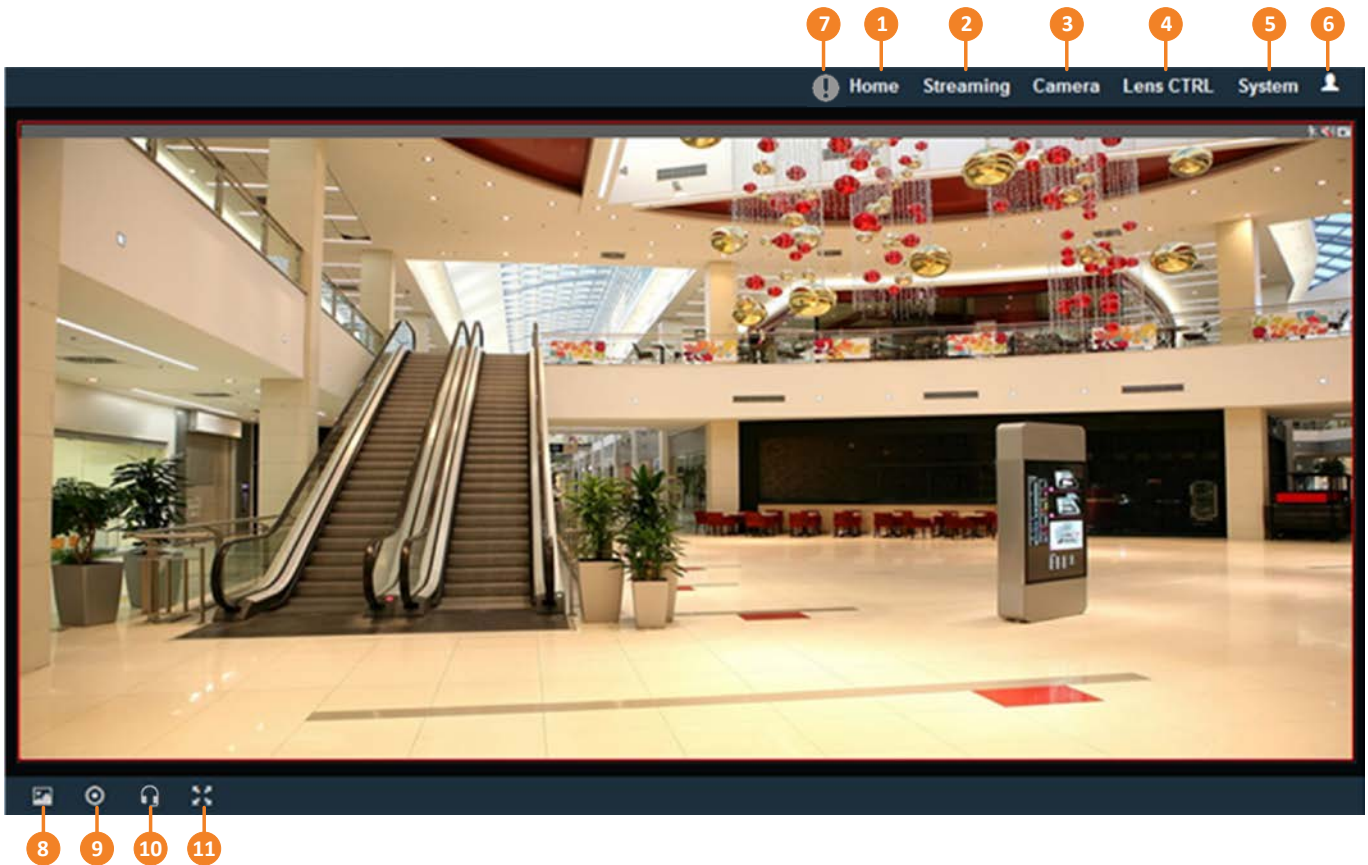

1. **Home**

Click the tab to display the Live View window. On the Live View Window, you can directly operate the zoom in / out by scrolling your mouse wheel over the image.

2. **Streaming**

Click the Streaming tab to display the Streaming quick setup panel. See 6.1 Streaming for more details.

3. **Camera**

Click the tab to display the Camera quick setup panel. See 6.2 Camera for more details.

4. **Lens CTRL**

Click the tab to display the Lens Control quick setup panel. See 6.3 Lens CTRL for more details. The function is only available for **EDN288M/368M/468M** and **EZN288M/368M/468M**.



5. **System**

Click the tab to enter the Settings page. See 7. System for more details.

6. **Account**

Click the  button to display the Account panel. You can check the current log-in information, or log out of the Web interface by clicking Logout. See 6.4 Account for more details.

## 7. Event signal icons

When an event is triggered, the alarm icon  at the top of the Live View window will turn red and blink  to alert the user. Click the icon to view the alarm information. On the pop-up window, click **Disarming / Arming** to stop / start prompting alarm information, click **Clear Alarm** to remove the current alarm information from the list.

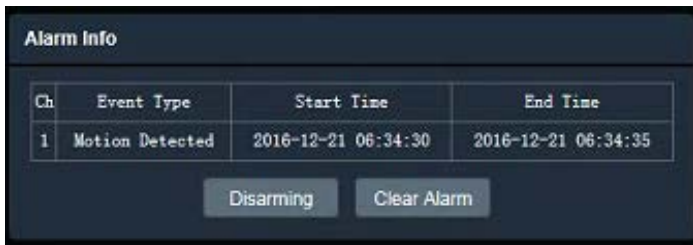

## 8. Snapshot

Click the **Snapshot** button to take a snapshot, and the storage folder will pop up automatically. By default, the snapshot will be saved at C:Everfocus/Value\_3M/Snapshots. To change the location, see **Live View Snapshot** in 7.1.9 Local *Settings*.

## 9. Record



Click the **Record** button to start / stop recording the current video stream. By default, the recordings will be saved at C:Everfocus/Value\_3M/Recordings. To change the location, see **Live View Recording** in 7.1.9 *Local Settings*.

## 10. Two-way Audio

Click the **Two-way Audio** buttons to switch the sound on / off for the speakers and microphones (if such external devices have been connected to the camera directly or via the network). To activate the Audio function, the **Complex Stream** must be selected. See **Stream** in 7.2.1.2 *Stream Settings*. Note that the camera provides the TRS line-in / out terminal I/O, therefore, TRS microphones / speakers with a (built-in) amplifier and external power supply are required.

## 11. Full Screen

Click to display the current camera stream in full screen. To exit full screen, right-click the mouse or press the **ESC** button on keyboard. Under full screen mode, these icons help you quickly be alerted of motion events, turn the audio on/off and take snapshots.

 When a motion event is triggered, the alarm icon will turn red  to alert the user.

 Click the **Audio** buttons to switch the sound on / off for the speakers (if such external devices have been connected to the camera directly or via the network).

 Click the **Snapshot** button to take a snapshot.

## 6. Quick Setup Panel

You can click the ► button to display the panel over the live view. Click the ◀ button to fix the panel on the right-side. Click the X button or the **Close Control Panel** button to close the panel.

### 6.1 Streaming

Click the **Streaming** tab to display the streaming quick setup panel.

Live View Stream	Main Stream
Stream Info	<input type="checkbox"/>
Alarm Info	<input type="checkbox"/>
Live View Size	Full
Live View Mode	0
Camera Title	CH01
Show Camera Title	<input checked="" type="checkbox"/>
Video Format	H264
Resolution	3M
Frame Rate	FULL
Rate Control	CBR
Quality	Highest
Bitrate (kbps)	6000
GOP	25
Close Control Panel	

**Live View Stream:** Select from Main Stream and Sub Stream.

**Stream Info:** Check to show the current bitrate and current frame rate at the top of the Live View window.

**Alarm Info:** Check to show the current triggered alarm type and trigger time.

**Live View Size:** Select the appropriate view size of the live view window.

**Live View Mode:** Slide the bar to set up the live stream performance between Real Time (smaller value) and Smooth way (larger value).

**Camera Title:** Type a name in the column to change the title.

**Show Camera Title:** Check to show the camera title.

**Format:** Select the encoding format – H.265 or H.264.

**Resolution:** Select the most suitable resolution for your needs.

**Frame Rate:** Select from 1fps to Full Frame. The default frame rate is Full Frame.

**Rate Control:** If required, select whether you want the stream to stream a **CBR** (Constant Bit Rate) or a **VBR** (Variable Bit Rate), and set the values of whichever option you choose.

**Quality:** Select the desired front end devices video coding quality, from Lowest to Highest.

**Bitrate (kbps):** For **CBR**, Slide the bar to adjust the customized Constant Bit Rate. For **VBR**, Slide the bar to adjust the Variable Constant Bit Rate limit.

**GOP:** Slide the bar to adjust the GOP (Group of pictures) level to adjust the frequency of generating I-frames per second.

## 6.2 Camera

Click the **Camera** tab to display the camera quick setup panel.

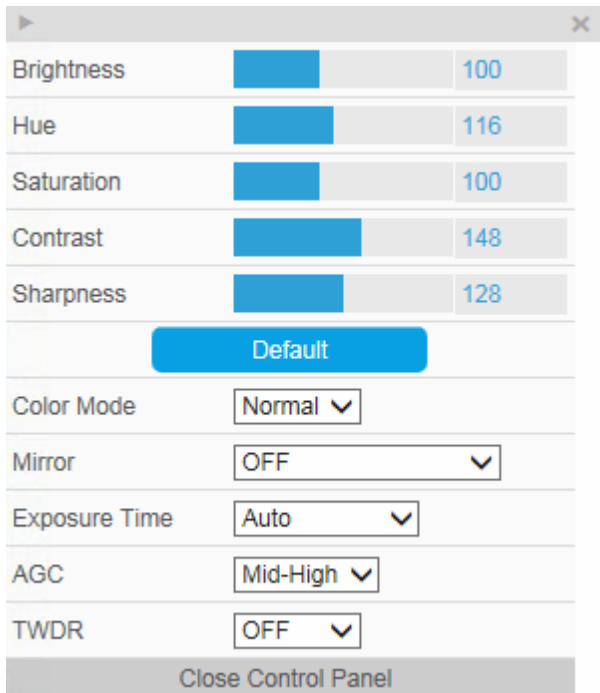

**Brightness:** Slide the bar to adjust brightness.

**Hue:** Slide the bar to adjust hue.

**Saturation:** Slide the bar to adjust saturation.

**Contrast:** Slide the bar to adjust contrast.

**Sharpness:** Slide the bar to adjust sharpness.

**Default:** Click to return the above value to factory default.

**Color Mode:** Select a color mode from Normal, Bright or Nature. The default color mode is Normal.

**Mirror:** Select a mirror mode from OFF, Horizontal Mirror, Vertical Mirror or 90 / 180 / 270 degree Rotation (see 7.2.3 *Image* for more details). The default Mirror mode is OFF.

**Exposure Time:** Select an exposure mode from auto or a shutter speed (from 1/25 ~ 1/10,000 seconds).

**AGC:** For **Auto** Exposure mode, you can further configure the **AGC** value. Select the Auto Gain Control level from Low to High (see 7.2.2 *Camera* for more details). The default AGC level is Mid-High.

**TWDR:** There are four value options: Close, Low, Mid and High (see 7.2.2 *Camera* for more details). The default TWDR mode is OFF.

## 6.3 Lens CTRL

Click the **Lens CTRL** tab to display the lens control quick setup panel.

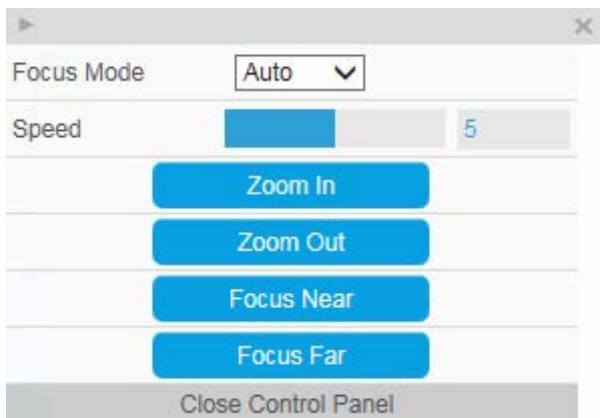

**Focus Mode:** Select a focus mode from Auto, or Manual. For **Manual**, use the **Focus Near / Focus Far** buttons to adjust focus.

**Speed:** Use the slider to adjust the speed for Zoom and Focus.

**Zoom In / Zoom Out:** Use the buttons to adjust Zoom in or out.

**Focus Near / Focus Far:** Use the buttons to adjust Focus near or far.

### Note:

1. By default, the system will automatically adjust the IR LED strength according to the scene, so please avoid IR reflection when installing the camera to prevent out-of-focus at night.
2. Under **Auto** focus mode, if the camera does not focus after switching the Day/Night mode, it is recommended to switch the focus mode to **Manual** and adjust focus manually.

## 6.4 Account

Click the  button to display the account panel.

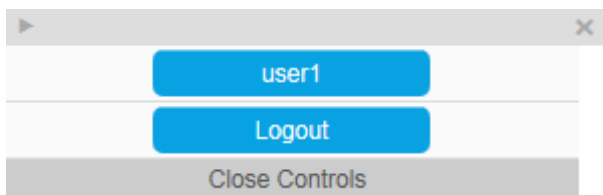

**Account:** Display the current user's login account.

**Logout:** Click to log out of the Web interface.

## 7. System

Click the **System** tab on the Live View Window to enter the setting page. Click the item of the one you want to see in the setting menu to display the details.

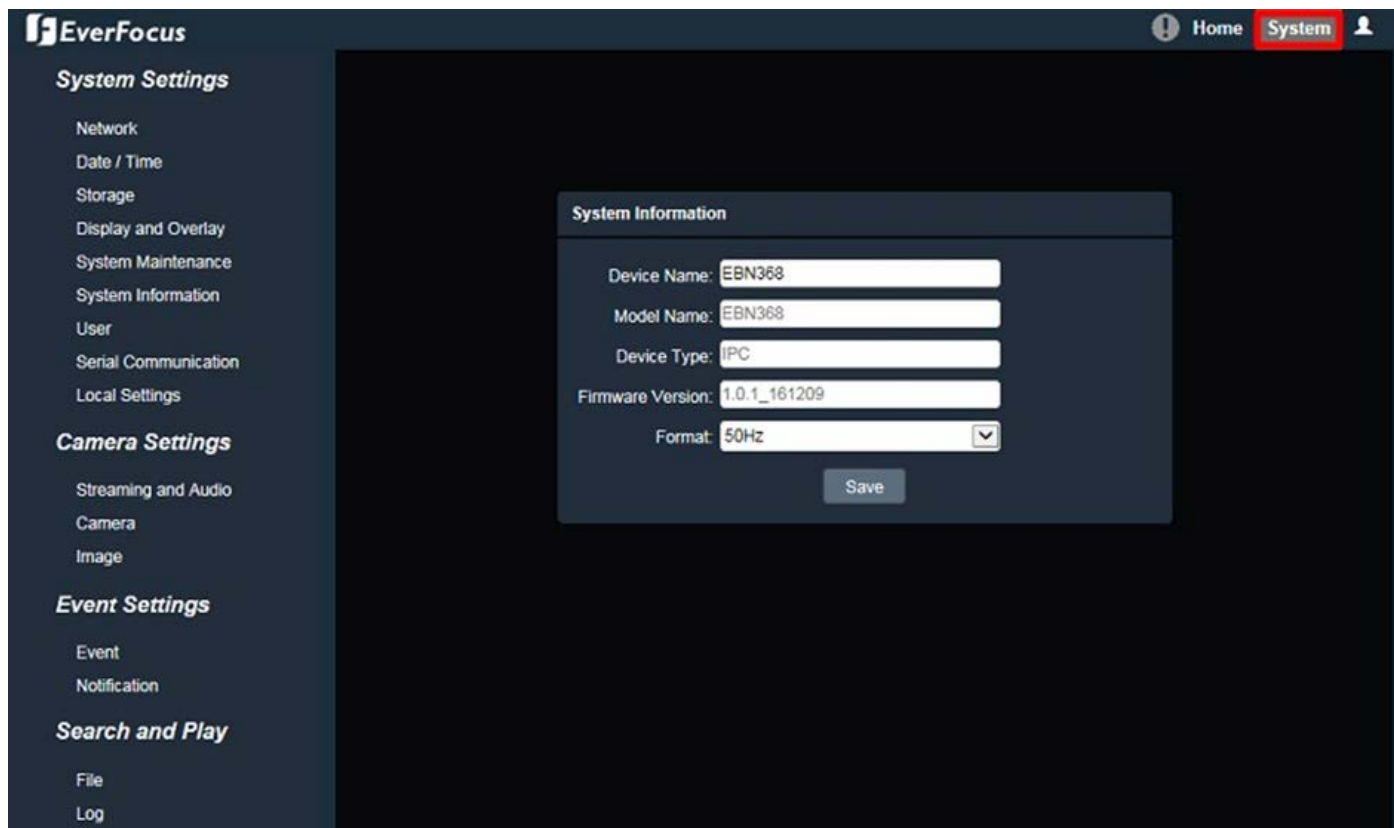



7.1. System Settings

7.1.1. Network

You can configure network-related settings, including IP, Multicast, DHCP, DDNS and Port on this page. Click the tab of the one you want to see.

7.1.1.1. IP Settings

Enter the IPv4 details in this area, which applies to your system.

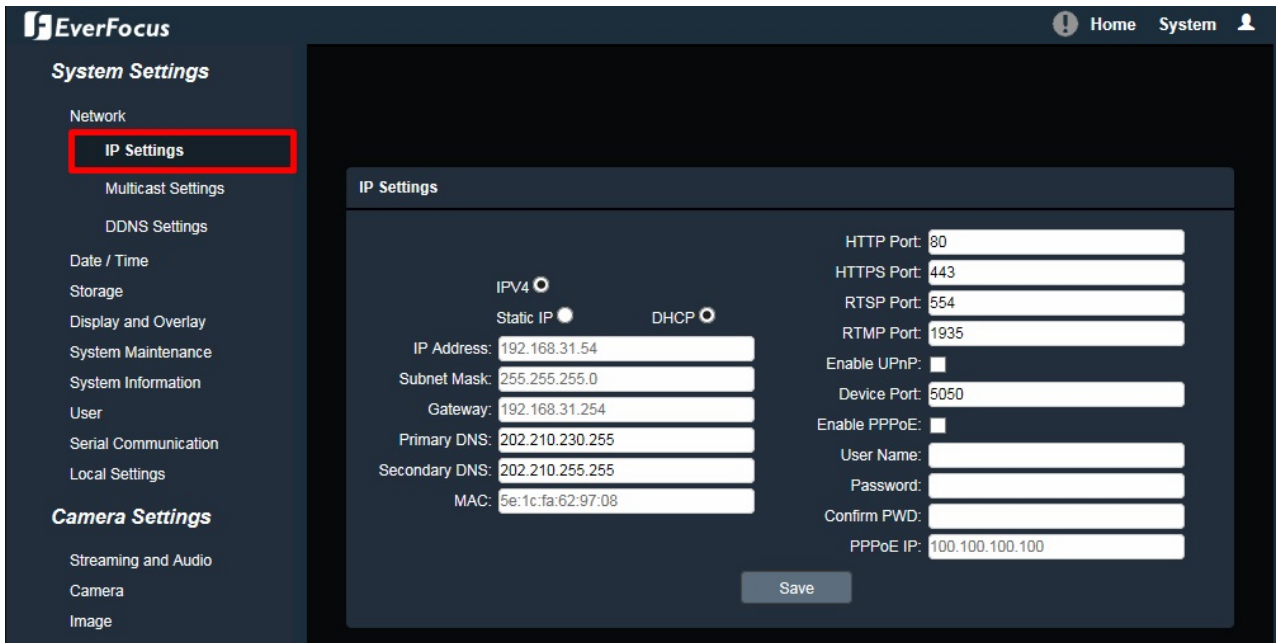

**IPV4:** Click the radio to enable IPv4 (Internet Protocol version 4), and then enter the IPv4 details in this area.

**Static IP:** Click the radio to enable Static IP. You can manually set the Static IP address. This type of address is stable and cannot change, but the user has to make sure there are no address conflicts with other network-connected devices.

**DHCP:** Click the radio to enable DHCP. This setting lets the system use an automatically assigned (dynamic) IP address. This address can change under certain circumstances. For instance, when the camera’s network switch / hub has to be rebooted. Do not assign to the DHCP server the same IP addresses used for the other network cameras and PCs with unique IP addresses.

**IP Address:** When DHCP is not used, the user needs to manually enter the IP address of the camera. Do not enter an IP address that is already used for your computer or other network cameras.

**Subnet Mask:** This field is used to set the subnet mask for your network, so that the IP camera will be recognized within the network. Example: 255.255.255.0. When DHCP is selected, the DHCP server will assign this value automatically.

**Gateway:** This field is used to set the gateway for your network so that the IP camera will be recognized within the network. When DHCP is selected, the DHCP server will assign this value automatically.

**Primary DNS:** Enter the IP address of the DNS server if this is provided by an ISP.

**Secondary DNS:** If your ISP provided you with a secondary DNS address, please enter it here.

**MAC:** The value of MAC address cannot be changed on this page, and are for reference only.

**HTTP Port:** Enter HTTP port numbers. The default port number is 80.

**HTTPS Port:** Enter HTTPS port numbers. The default port number is 443.

**RTSP Port:** Use domain name to access and login device need mapping RTSP. The default port number is 554.

**RTMP Port:** Use domain name to access and login device need mapping RTMP. The default port number is 1935.

**Enable UPnP:** Click the box to enable UPnP. Promoted by the UPnP Forum (Universal Plug and Play), the UPnP is a networking architecture providing compatibility among networked devices listed in the networked device table. Enable the UPnP function means you can directly connect the cameras listed in the networked device table by clicking on them.

**Device Port:** Enter device port numbers. The default port number is 5050.

**Enable PPPoE:** Click the box to enable PPPoE. This is a DSL-connection application. The ISP will ask the user to input a username and password. Contact your ISP for these details.

**User Name:** Enter the account's username for PPPoE.

**Password:** Enter the account's password for PPPoE.

**Confirm PWD:** Enter the password again to confirm it.

**PPPoE IP:** Enter the device's dynamic IP address.

After complete the settings, click **Save** to apply the changes.

### 7.1.1.2. Multicast Settings

Enable if required, fill in the setting options for main stream / sub stream video and audio. For more details, please refer to Appendix B. Enabling the Multicast Function.

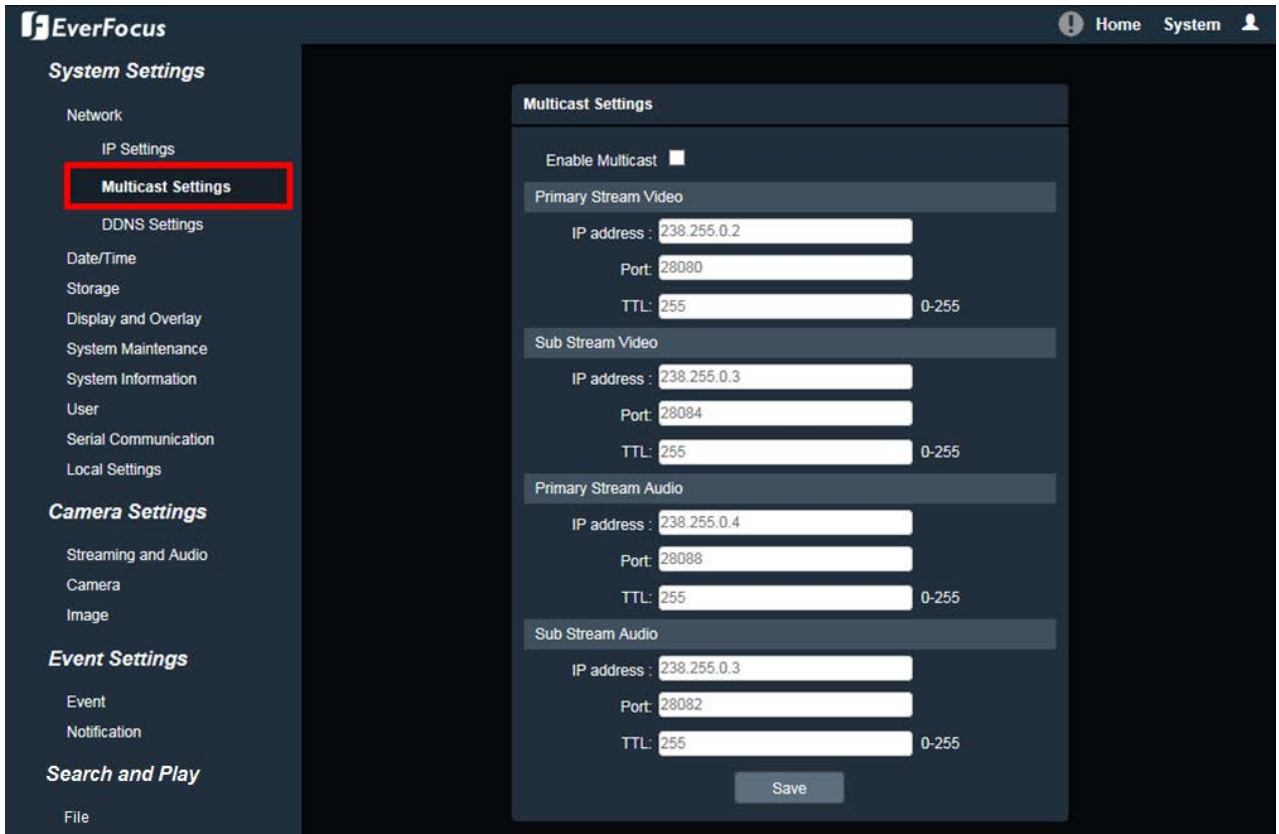

**Enable Multicast:** Check the box to enable the Multicast function.

**IP Address:** Fill in the multicast IP address. IP addresses in the range of 224.0.0.0 through 239.255.255.255 are reserved for multicasting. For devices, you can use 225.x.x.x - 232.x.x.x and 234.x.x.x - 238.x.x.x. Click [here](#) for more details.

**Port:** Change the port number if necessary.

**TTL:** Input a Time-To-Live (TTL) value. The TTL value specifies the number of routers (hops) that multicast traffic is permitted to pass through before expiring on the network.

After complete the settings, click **Save** to apply the changes.

7.1.1.3. DDNS Settings

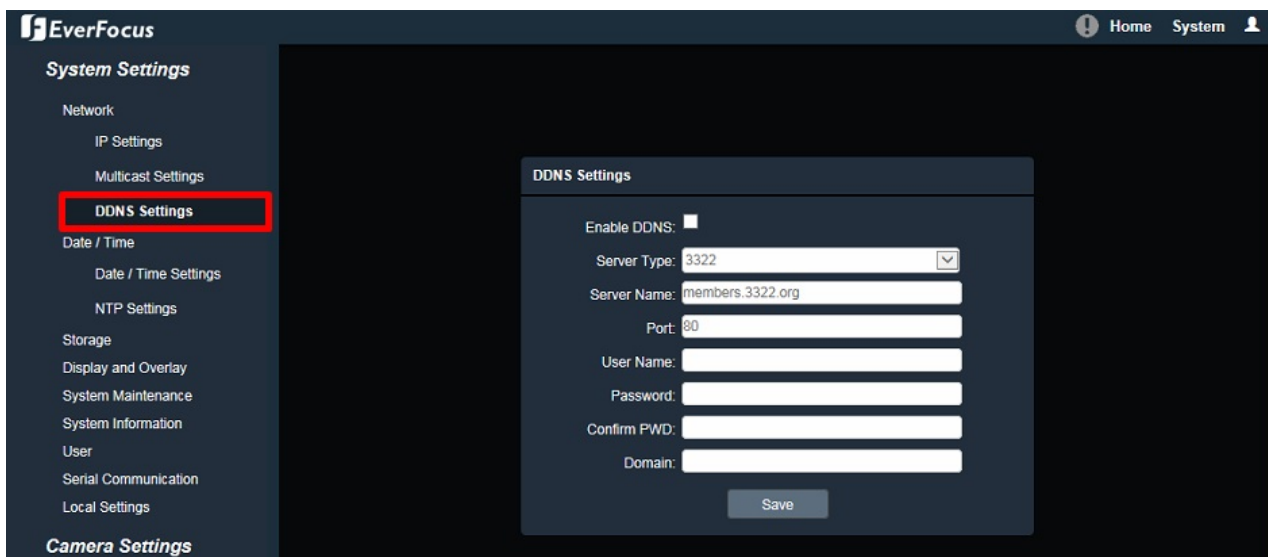

DDNS (Dynamic Domain Name System) is a service used to map a domain name to the dynamic IP address of a network device. You can set up the DDNS service for remote access to the IP camera. DDNS assigns a domain name (URL) to the IP camera, so that the user does not need to go through the trouble of checking if the IP address assigned by DHCP Server has changed. Once the IP is changed, the IP camera will automatically update the information to the DDNS to ensure it is always available for remote access. For setting up the DDNS function, please refer to [Appendix E. Setting up DDNS Function](#).

Before enabling the following DDNS function, user should have applied for a host name from the DDS service provider’s website. We support these DDNS server providers: www.everfocusddns.com, members.dyndns.org, ddns.oray.org, dynupdate.no-ip.com, members.3322.org and www.dnsdynamic.org

**Note:** We highly recommend that you use **xxxx.everfocusddns.com** for the simplicity of setting up your IP cameras.

**Enable DDNS:** Check the box to enable DDNS function.

**Service:** You can either apply for a host name from **EverFocus** or other DDNS server providers (**Dyndns**, **PeanutHull**, **NO-IP**, **3322** and **DnsDynamic**). If you choose the EverFocus DDNS server, you can obtain a free host name from EverFocus.

**From EverFocus:** To obtain a free host name from EverFocus, type a desired host name in the **Domain** field (there is no need to enter username / password).

**From other DDNS server providers:** To obtain a domain name from one of the three DDNS server providers, you have to register your name with the provider first, and then select the provider

and fill in the required information. Please refer to the specific DDNS company's website for further information.

**Server Name:** The server name of the DDNS provider. For example, *www.everfocusddns.com*. You can modify the server name if required.

**Port:** Enter the port numbers. The default port number is 80.

**User Name / Password:** Type the login account of your DDNS server provider. Type the password again in the **Confirm PWD** field.

**Domain:** Type the registered domain name from the DDNS server provider.

After complete the settings, click **Save** to apply the changes.

**Note:**

1. In order to support the full functionality of the camera, you must open the port numbers (80, 554, 443) on the router for remote access to the IP camera. This function is available on most routers in the market and is often known as "Port Forwarding". To set up Port Forwarding, please consult the manual of the router.
2. In certain router models, it is possible that you will not be able to access the camera using DDNS while inside the router's network. Please try using a PC located outside of your router's network.

**Default Ports on All EverFocus IP Cameras:**

HTTP: 80

RTSP: 554

HTTPS: 443

### 7.1.2. Date / Time

You can set up the system’s time and NTP server. Click the tab of the one you want to see.

**Note:** Before start operating the IP camera, please make sure the camera date and time are correct.

#### 7.1.2.1. Date/Time Settings

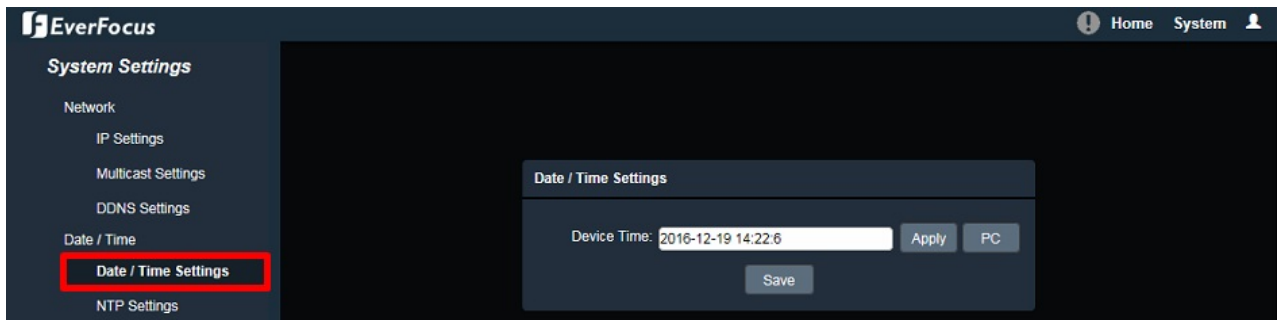

**Device Time:** Display the device current time. You can manually set up and click **Apply** to save the time setting. Click **PC** to automatically adjust the camera’s time by synchronizing with the PC.

After complete the settings, click **Save** to apply the changes.

#### 7.1.2.2. NTP Settings

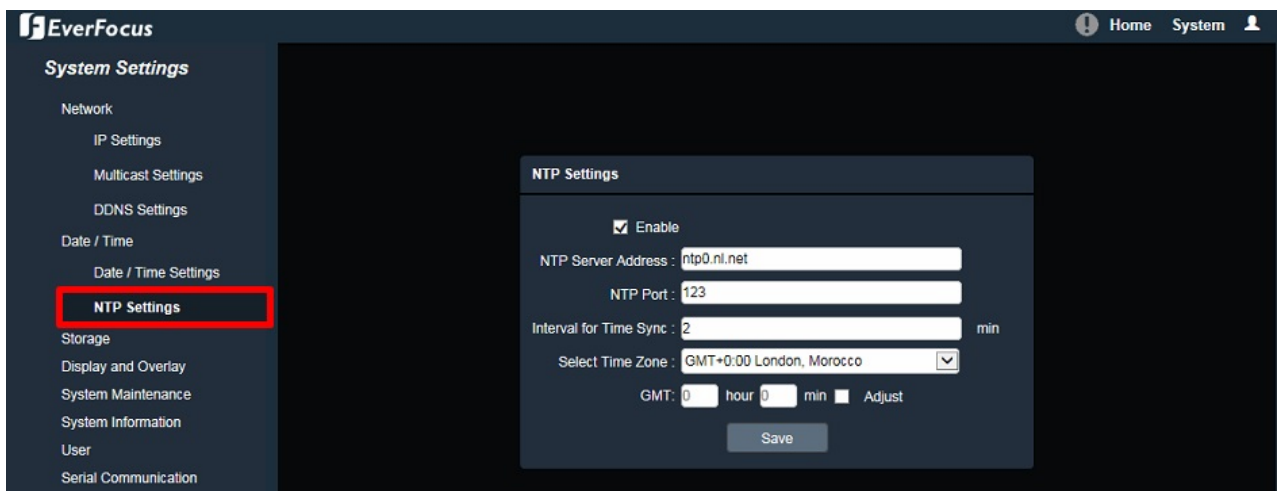

**Enable:** Check the box to enable NTP function.

**NTP Server Address:** Enter the Network Time Protocol server, if applicable. The camera’s time will be automatically adjusted by synchronizing with the NTP server.

**NTP Port:** Enter the Network Time Protocol port. The default port number is 123.

**Interval for Time Sync:** Input the interval time for automatic time synchronization with NTP.

**Select Time Zone:** Select the time zone of the camera’s location.

**GMT:** Check the **Adjust** box to enable adjusting the offset and set the desired minute in the **min** field.

After complete the settings, click **Save** to apply the changes.

### 7.1.2.3. DST Settings

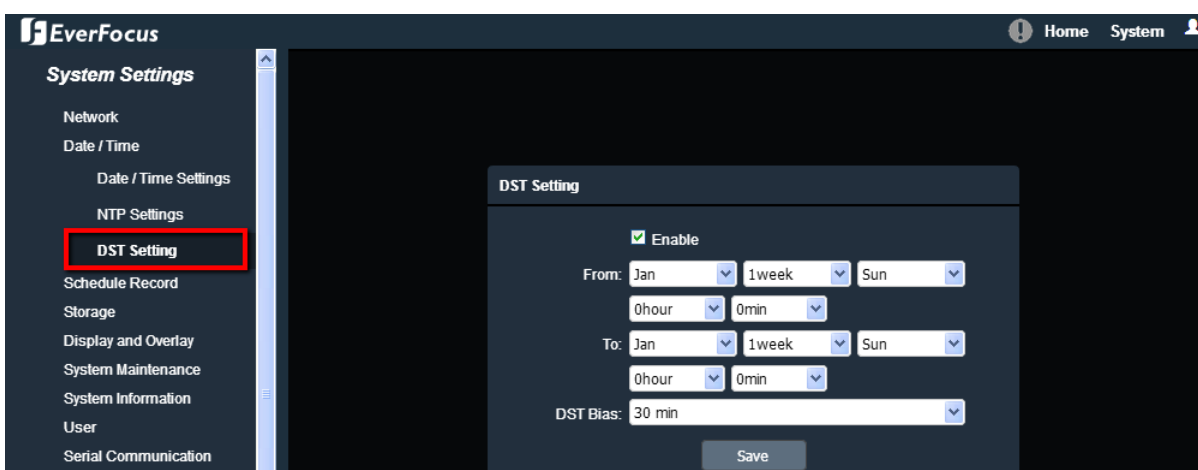

**Enable:** Check the box to enable DST function.

**From:** Select the date and time when the region’s daylight saving time to start.

**To:** Select the date and time when the region’s daylight saving time to end.

**DST Bias:** Select a shift time for the DST function.

After complete the settings, click **Save** to apply the changes.

7.1.3. Schedule Record

You can set up schedule record for the camera. This page will only appear when a micro SD card has been inserted to the card slot (please refer to 4.4.2 *Inserting a Micro SD Card*).

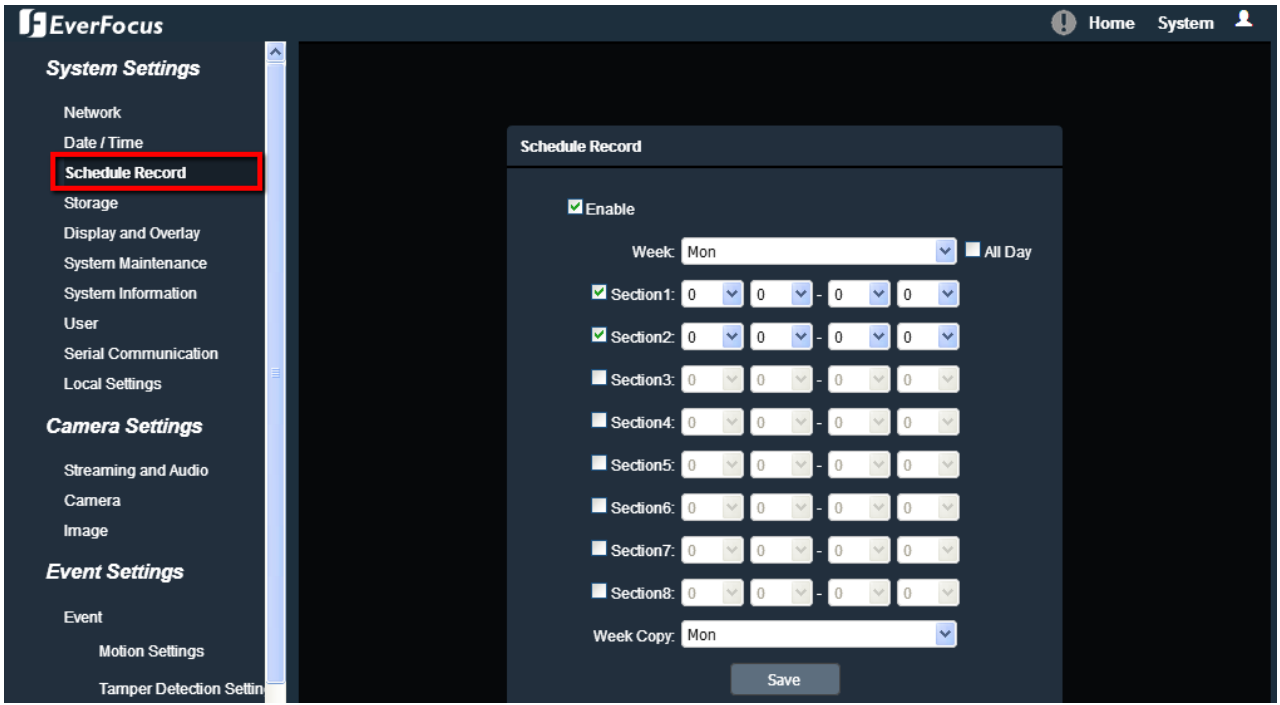

To set up a Record Schedule:

1. Check the **Enable** box to enable the Schedule Record function.
2. Select a day (Monday ~ Sunday) from the **Week** drop-down list to configure the schedule.
3. Set up schedules to active the Schedule Record function. Check the box of the desired section to configure the schedule, and select a start / end time from the drop-down list for the section.
4. You can optionally use the **Week Copy** function to copy the configurations and then apply to other days.
5. Click **Save** to save the settings.

**Note:**

1. EBN series models do not support the Schedule Record function.
2. Before you insert or remove the SD card, please turn off the IP camera first.



7.1.4. Storage

You can check the SD Card utility or format the SD Card using this page.

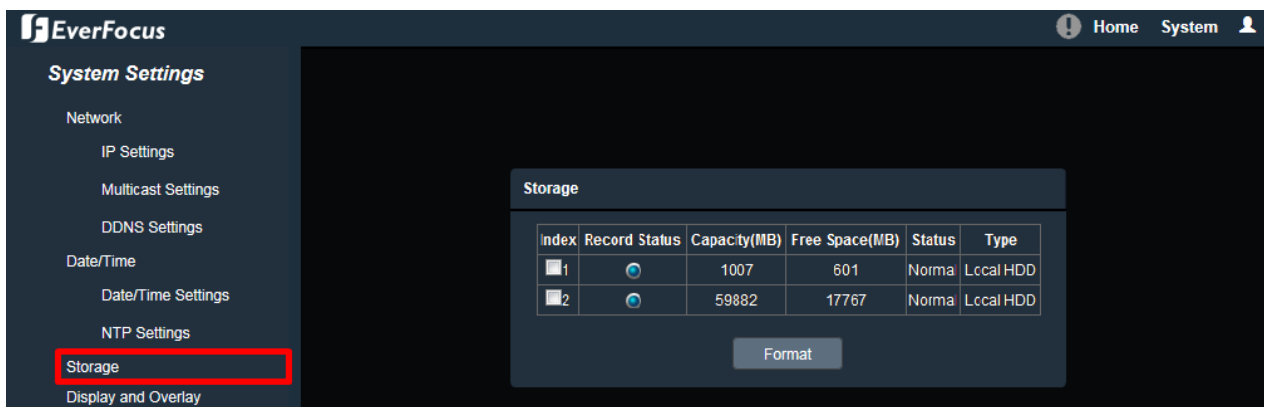

If a micro SD card has been inserted to the micro SD card slot of the camera, the micro SD card information will be displayed in this field, such as capacity, available free space and record status. To format the card, click the **Format** button and all data saved on the micro SD card will be removed (see 4.4.2 Inserting a Micro SD Card).

**Note:**

1. EBN series models do not support the Schedule Record function.
2. Before you insert or remove the SD card, please turn off the IP camera first.

### 7.1.5. Display and Overlay

You can enable displaying camera information on the live view / backup images using this page.

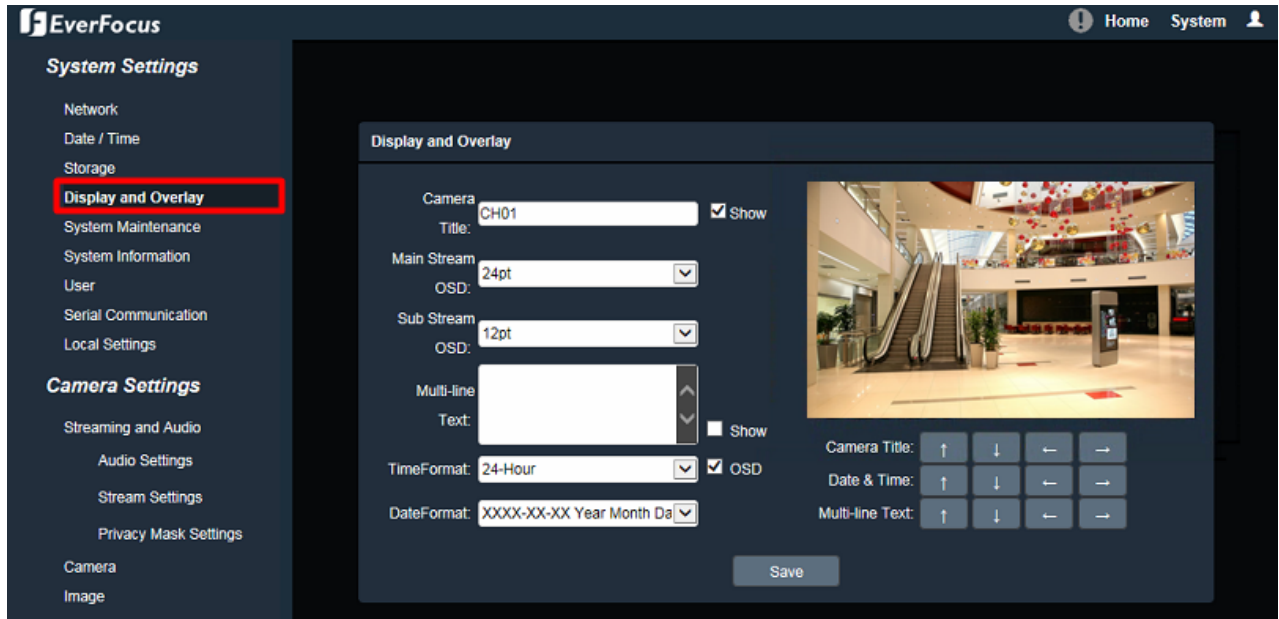

**Camera Title:** Check the **Show** box to enable the Camera Title function. Type a name in the column to change the title.

**Main Stream OSD:** Select the font size for main stream OSD.

**Sub Stream OSD:** Select the font size for sub stream OSD.

**Multi-line Text:** Enter the desired text in the input field, and check the **Show** box to display the text.

**Time Format:** Check the **OSD** box to enable the Time Format function. Select the desired time format from the drop-down list.

**Date Format:** Check the **OSD** box to enable the Date Format function. Select the desired date format from the drop-down list.



**Camera Title:** You can adjust the position of the title by the arrow buttons.

**Date & Time:** You can adjust the position of the date / time by the arrow buttons.

**Multi-line Text:** You can adjust the position of the Multi OSD by the arrow buttons.

7.1.6. System Maintenance

7.1.5.1. Upgrade Firmware

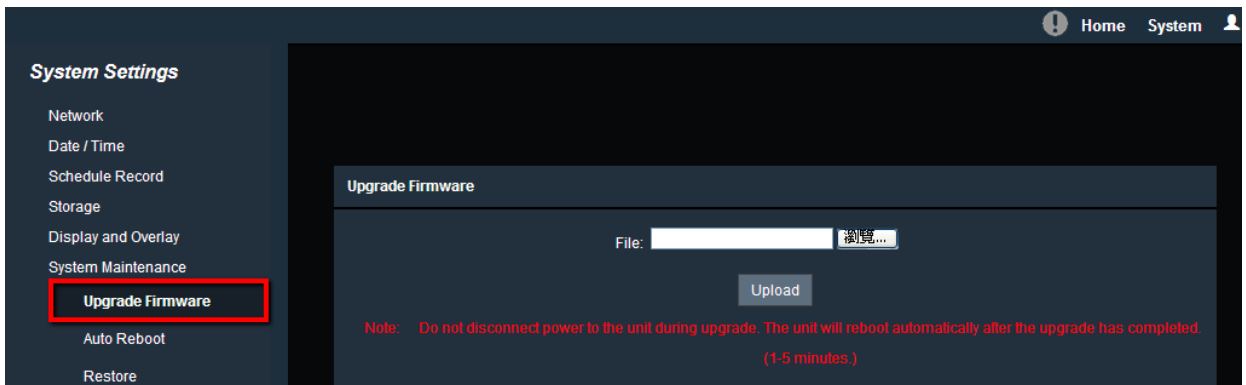

Click the **Browse** button to find a previously prepared firmware upgrade file. Click the **Update** button to install the new firmware. You can also upgrade firmware using IP Utility, see [8. Upgrading Firmware Using IP Utility](#).

**Note:**

1. System updating should only be accomplished by trained staff.
2. Do not disconnect power to the IP camera during the upgrade sequence. The IP camera will reboot automatically after the upgrade has completed (1-5 minutes).

7.1.5.2. Auto Reboot

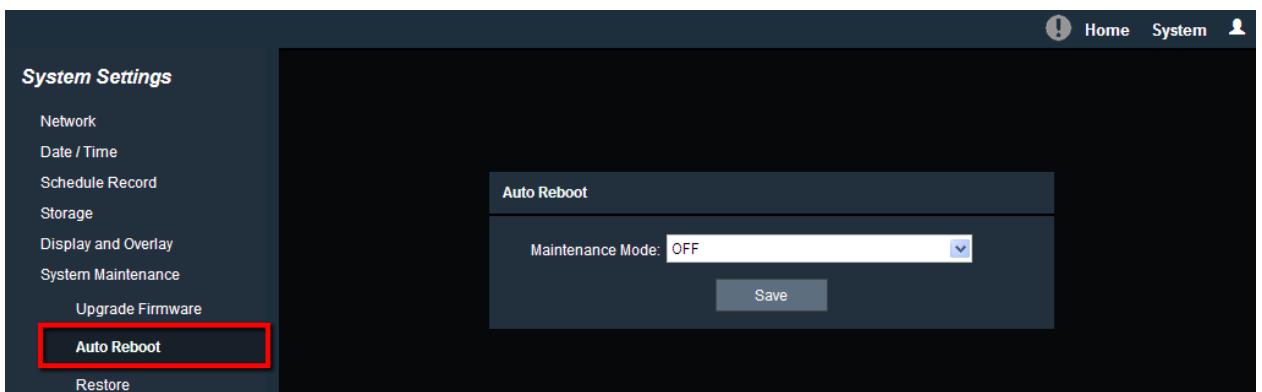

Select OFF to disable the Auto Reboot function, or select an interval for the Auto Reboot function from Every Day, Every Week or One Time. The IP camera will automatically reboot at the specified time.

- **OFF:** The IP camera will not reboot automatically.
- **Every Day:** The IP camera will reboot automatically every day at the specified time (hh:mm).

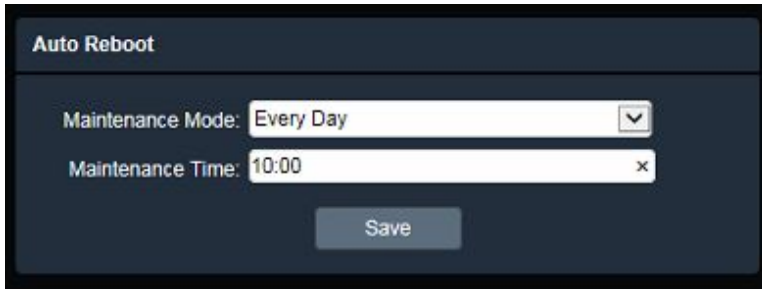

- **Every Week:** On the selected day, the IP camera will reboot automatically at the specified time (hh:mm).

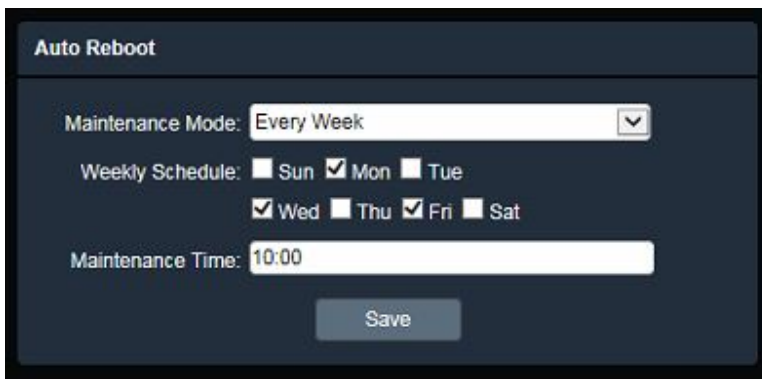

- **One Time:** The IP camera will reboot at the specified time (YYYY/MM/DD hh:mm:ss).

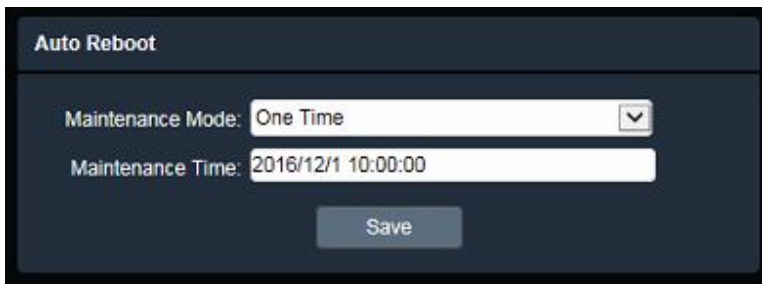

After complete the settings, click **Save** to apply the changes.

### 7.1.5.3. Restore

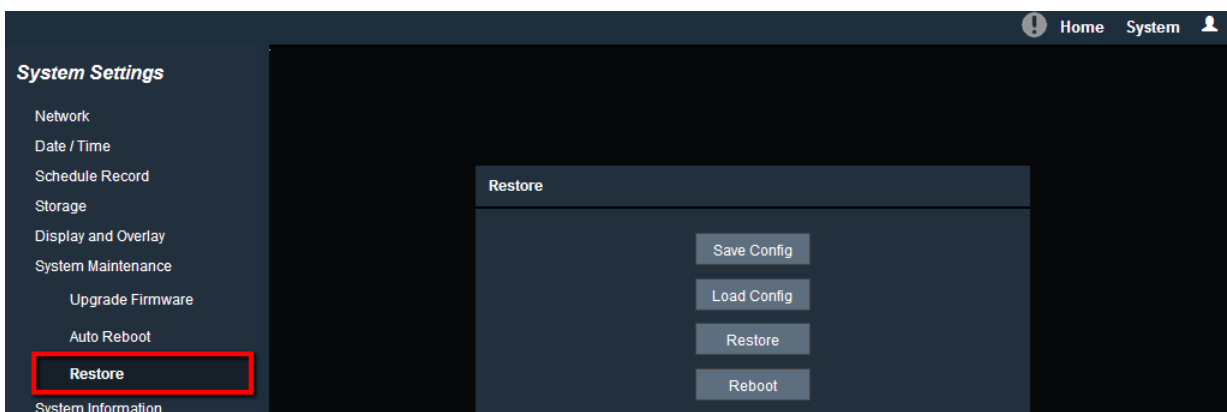

**Save Config:** To make a backup file of the machine's current configurations, click this button to export all the configurations to a configuration file. This will enable the user to reload these configuration settings if the settings are changed and there is unexpected behavior.

**Load Config:** Click to import a previously prepared configuration file and then apply the parameters from the configuration file to the system.

**Restore:** This button should be used with caution. Clicking this button will return the selected camera settings to the factory default values.

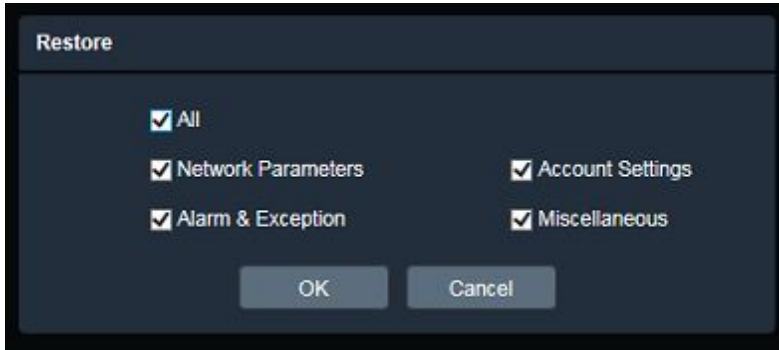

**Reboot:** Click to reboot the IP camera without changing any of the settings. Use this function if the IP camera is not behaving as expected.

7.1.7. System Information

You can check the system information or set up NTSC / PAL on this page.

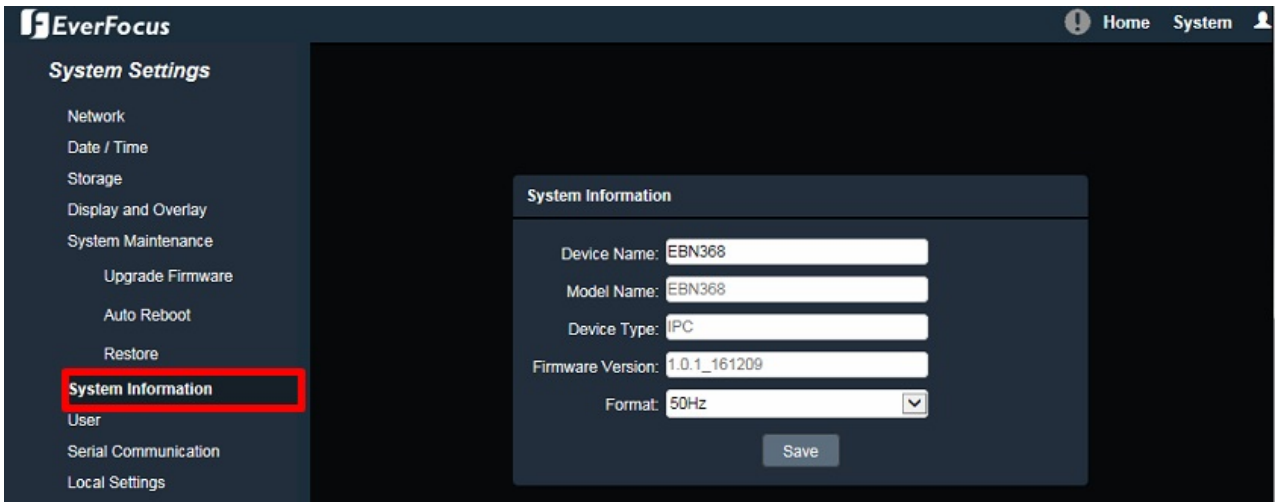

**Device Name:** If required, enter a desired name for the machine. This name will be visible in the Machine Name field of the IP Utility software.

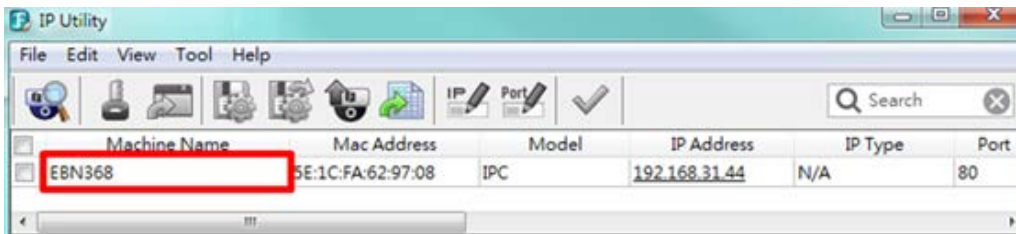

**Model Name:** Display the model name of the camera. The values cannot be changed on this page.

**Device Type:** Display the device type. The values cannot be changed on this page.

**Firmware Version:** Display the current software version. The values cannot be changed on this page.

**Format:** Select NTSC (60Hz) or PAL (50Hz) for your local scanning system.

**Note:** Modifying the Format will cause the system to reboot automatically. Please create a new network connection to the IP camera when the reboot is complete.

After complete the settings, click **Save** to apply the changes.

7.1.8. User

The system administrator can create user accounts on this page.

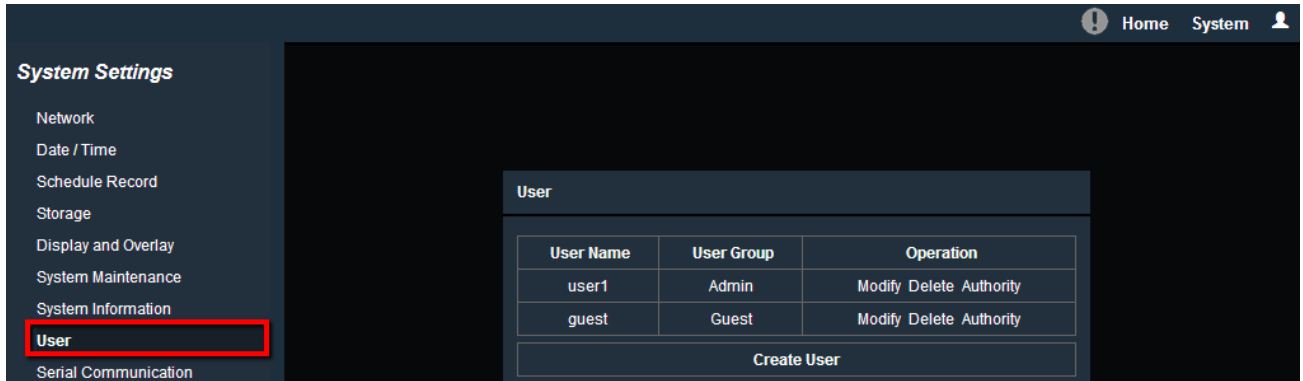

To add a user account:

1. Click the **Create User** button and the following dialog box appears.

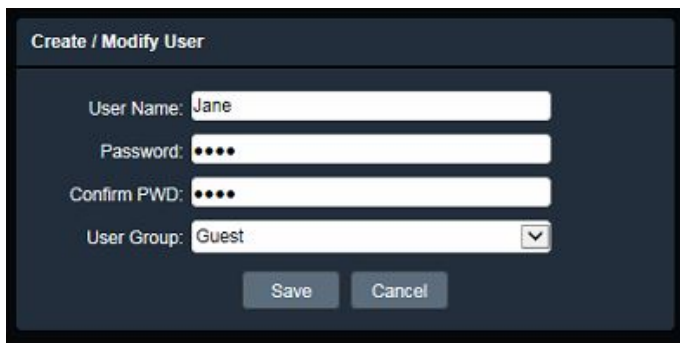

2. Type the user name and password for the account. Type the password again in the **Confirm PWD** field.
3. Select an authority level for the user account from the **User Group** drop-down list. The default authority for each group is listed below. You can still configure the privileges for each account by clicking **Authority**.

Default Authority	Admin	Guest	Operator
Remote PTZ	Yes	-	Yes
Remotely Playback	Yes	Yes	Yes
Remote Parameter Setting	Yes	-	-
Remotely Query Log	Yes	Yes	Yes
Remotely Upgrade and Format	Yes	-	Yes
Remote 2-Way Audio	Yes	-	Yes
Remote Live View	Yes	Yes	Yes
Remotely Reboot	Yes	Yes	Yes

**Note:** Multiple Guest / Operator account can be configured, but only one Admin account can be created for an IP camera.

4. Click **Save** to add the user account.

To modify a user account:

1. Click the **Modify** button in the Operation column. The following dialog box appears.

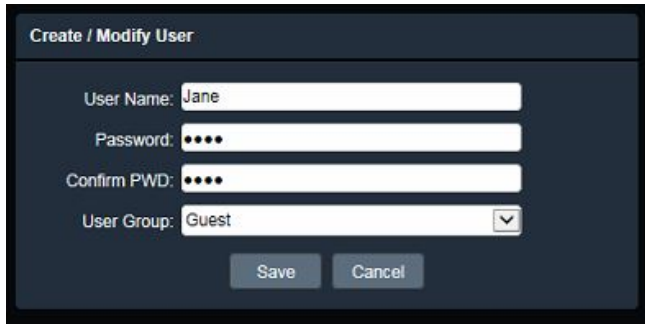

2. Edit the user name and password. Type the password again in the **Confirm PWD** field.
3. Edit the authority level for the user account from the **User Group** drop-down list.
4. Click **Save** to save all the settings.

To delete a user account:

1. Click the **Delete** button in the Operation column. The following dialog box appears. The following dialog box appears.

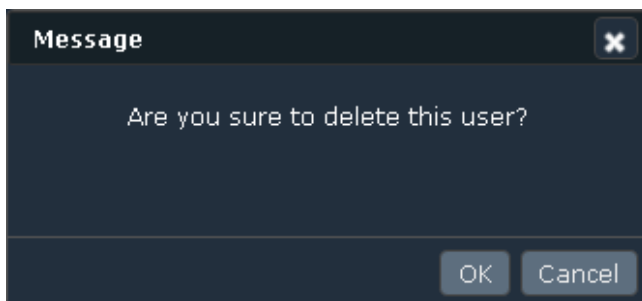

2. Click **OK** to delete the user account.

To set up privileges for a user account:

1. Click the **Authority** button in the Operation column. The following dialog box appears.

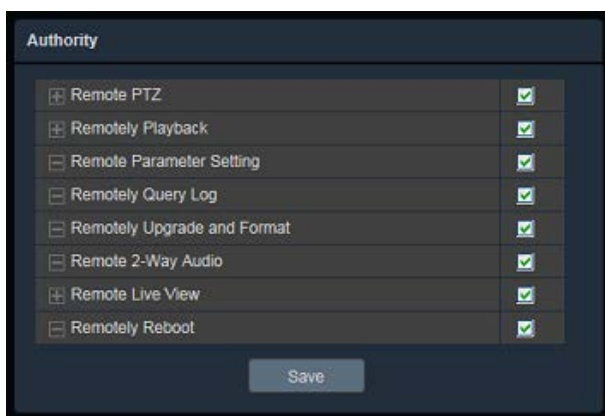

2. Check the box to grant the privileges to this user account.
3. Click **Save** to save all the settings.



### 7.1.9. Serial Communication

The function is currently reserved.

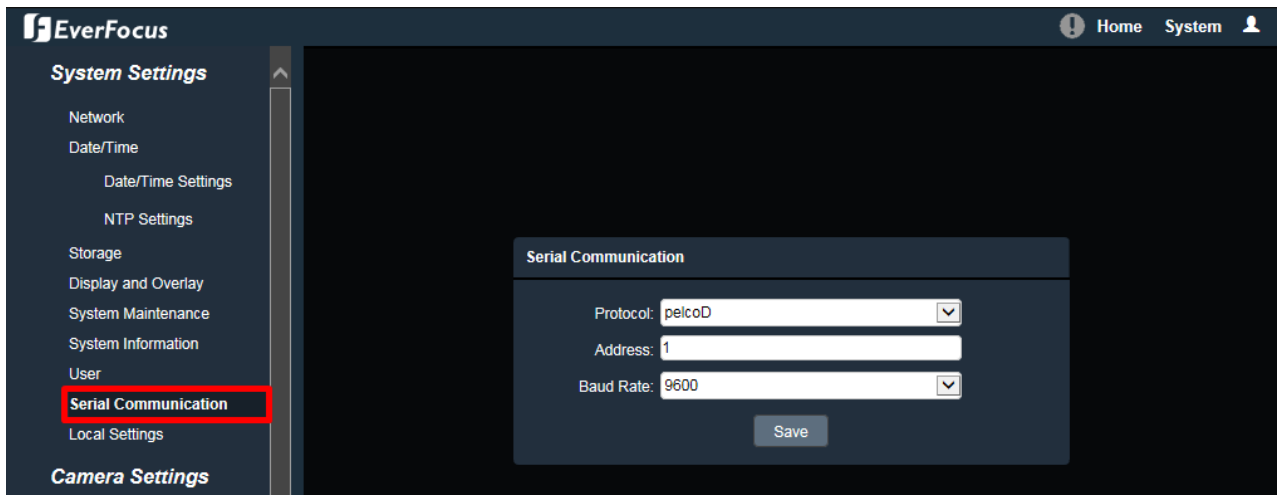

**Protocol:** Select a protocol from Pelco-D or Pelco-P.

**Address:** Enter the address from 0 to 255.

**Baud Rate:** This field is to set the speed at which is used to transmit instruction or information through the RS-485 port (reserved) on the video encoder. There are six different speeds, from 50 to 115200.

After complete the settings, click **Save** to apply the changes.

**7.1.10. Local Settings**

You can configure the storage path for storing the recordings / snapshot on your PC.

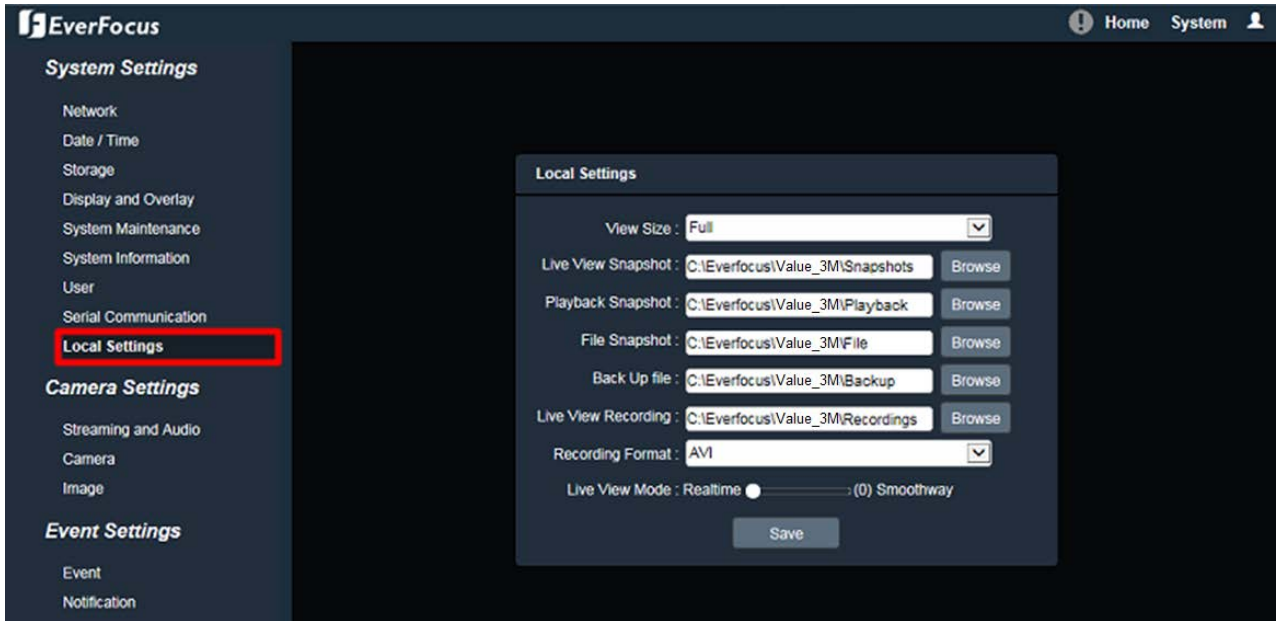

**View Size:** Select the appropriate view size of the live view window.

**Live View Snapshot:** Type the storage path for snapshots captured in the Home page (Live View window).

**Playback Snapshot:** Type the storage path for snapshots captured in the Playback page.

**File Snapshot:** Type the storage path for snapshots captured in the File page.

**Backup file:** Type the storage path for recording files backed up in the Playback page.

**Live View Recording:** Type the storage path for recordings recorded in the Home page (Live View window).

**Record Format:** Currently only AVI is available.

**Live View Mode:** Slide the bar to set up the live stream performance between Real Time and Smooth way.

After complete the settings, click **Save** to apply the changes.

**Note:** The Playback related settings are only functional if the micro SD Card has been inserted in the camera’s micro SD card slot.

## 7.2. Camera Settings

You can configure camera related settings, such as video, audio, image and privacy mask.

### 7.2.1. Streaming and Audio

#### 7.2.1.1. Audio Settings

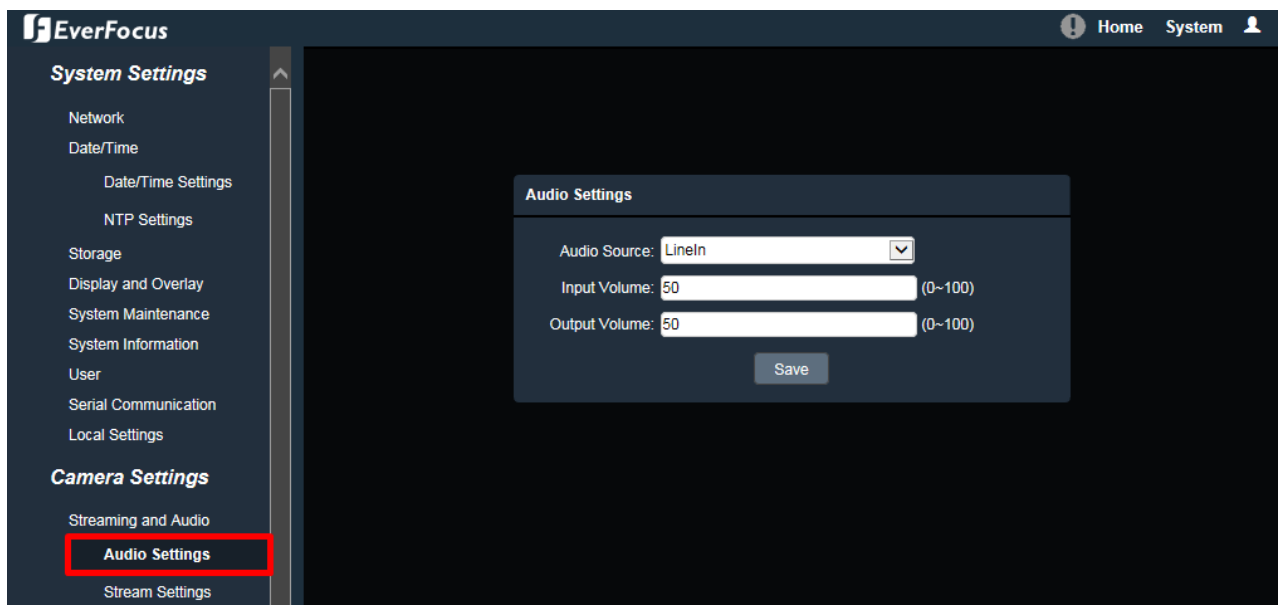

The camera can transmit audio to your computer if you have connected an external line-in audio device to its audio Input. Select an audio source (currently only Line-in is available) then adjust the audio input / output volume. Note that the camera provides the line-in / out audio ports, therefore, microphones / speakers with an (built-in) amplifier and external power supply are required.

After complete the settings, click **Save** to apply the changes.

7.2.1.2. Stream Settings

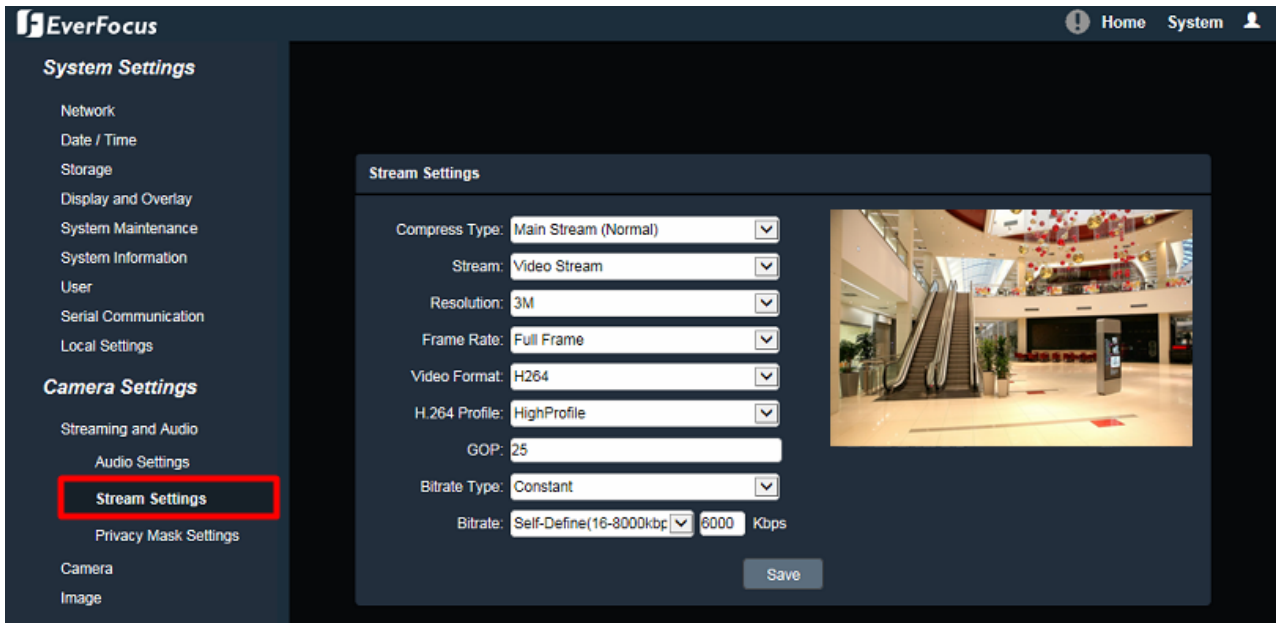

**Compress Type:** Select from Main Stream or Sub Stream.

**Stream:** Select from Video Stream (video only) or Complex Stream (video & audio).

**Resolution:** Select the most suitable resolution for your needs.

**Frame Rate:** Select from 1fps to Full Frame. The default frame rate is Full Frame.

**Video Format:** Select the encoding format – H.265 or H.264.

**H264 Profile:** Select the video coding level from Main Profile, Baseline or High Profile.

**GOP:** Enter the I-frame interval time from 2 to 255 to adjust the frequency of generating I-frames per second.

**Bitrate Type:** If required, select whether you want the stream to stream a **Constant** Bit Rate or a **Variable** Bit Rate, and set the values of whichever option you choose.

**Bitrate:** For **Constant** Bit Rate only. Select the desired Bit Rate from the drop-down list or enter a customized Constant Bit Rate (16 to 8000 kbit) in the  **Kbps** field.

**Max Bitrate:** For **Variable** Bit Rate only. Select the desired Max Bit Rate from the drop-down list or enter a customized Max Bit Rate (16 to 8000 kbit) in the  **Kbps** field.

**Quality:** For **Variable** Bit Rate only. Select the desired front end devices video coding quality, from Lowest to Highest.

After complete the settings, click **Save** to apply the changes.

**Note:** If you connect to the camera via the Internet and experience a delay (lag time) in the video feed, try to reduce the quality and resolution of the streams – but keep the frame rate at its maximum.

### 7.2.1.3. Privacy Mask Settings

The Privacy Mask can block out sensitive areas from view, covering the areas with black boxes in both live view and recorded clips. This feature is useful when users' don't want the sensitive information visible. Up to four Privacy Masks can be configured.

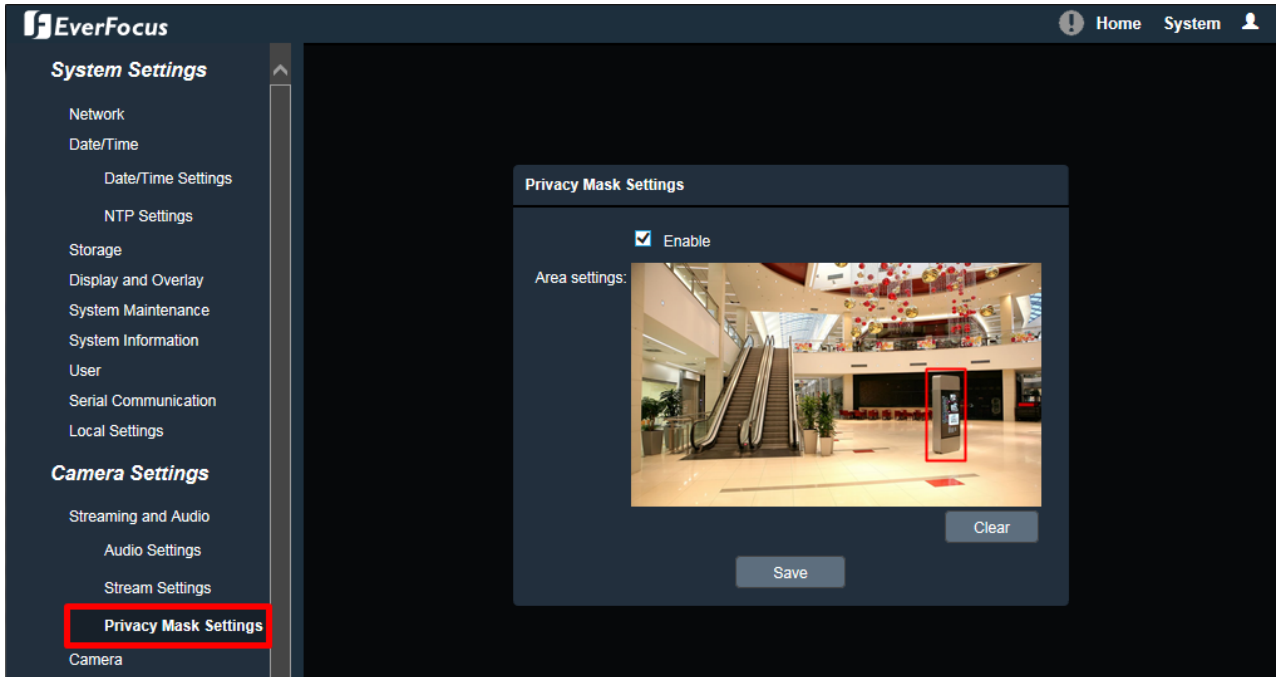

To set up a Privacy Mask:

1. Check the **Enable** box to enable the Privacy Mask function.
2. In the **Area Settings** field, move the cursor to the position where you want the mask rectangle to start and then click it. Move the cursor to the position (diagonally opposing corner) where you want the mask rectangle to end and then click it.
3. You can remove the configured mask by clicking the **Clear** button.

After complete the settings, click **Save** to apply the settings.

7.2.2. Camera

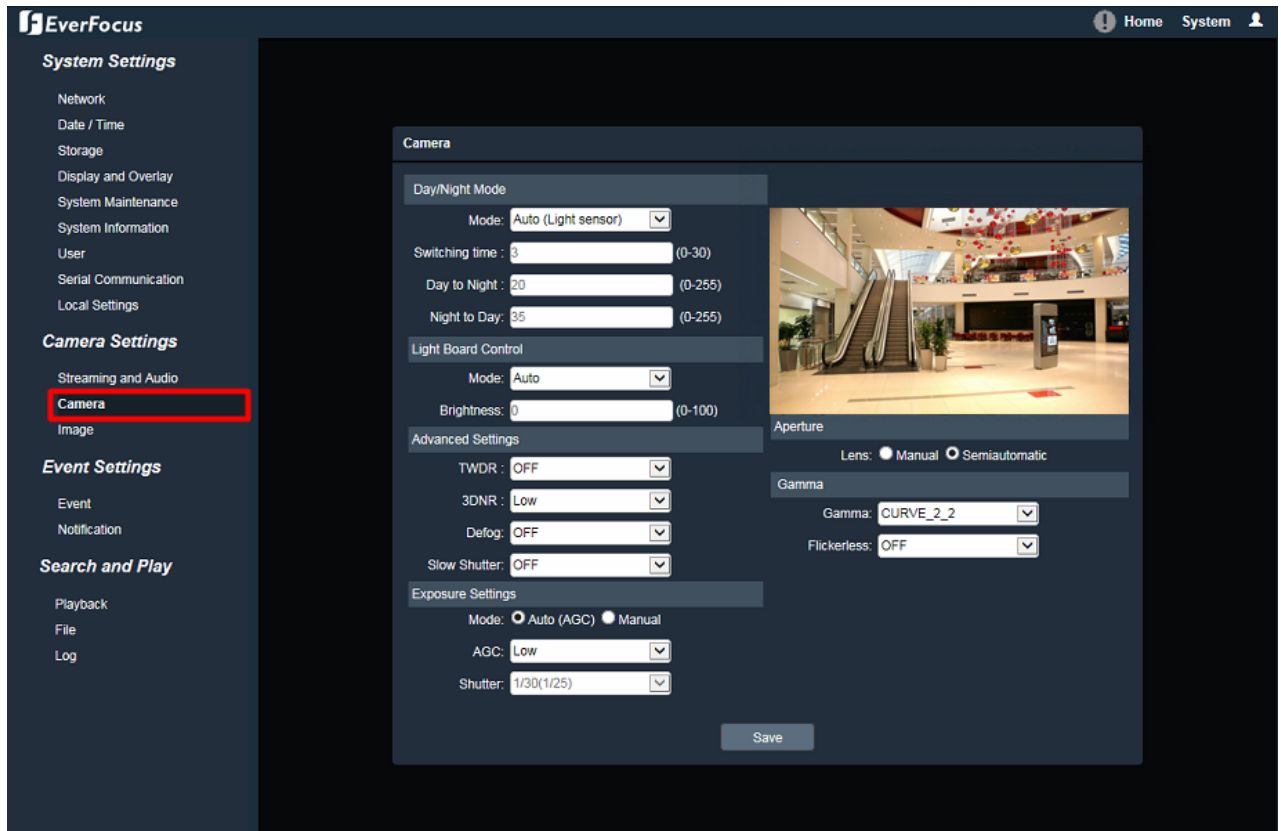

**Day/Night Mode**

**Mode:** Select a mode from the drop-down list. The default Day/Night mode is Auto(Light sensor).

- **Auto(Light sensor):** Select to let the camera automatically switch to Day mode (color images) or Night mode (black and white images with IR LED on) based on the light sensor’s detection on the light level.
- **Auto(AGC):** Select to let the camera automatically switch to Day mode (color images) or Night mode (black and white images with IR LED on) based on the AGC value of the current video image.
- **Color:** Select to keep the camera in Day mode (color images with IR LED off), even in nighttime.
- **Black White:** Select to keep the camera in Night mode (black and white images with IR LED on), even in daytime.

**Switching Time:** Select the transition duration a switching will take for **Auto(AGC)** Day/Night Mode, from 0 to 30 second(s). The default switching time is 3 seconds.

**Day to Night:** You can configure the sensitivity for **Auto(AGC)** Day/Night Mode ranging from 0-255. The camera will automatically switch from day mode to night mode based on the setup sensitivity. The default value is 20.

**Night to Day:** You can configure the sensitivity for **Auto(AGC)** Day/Night Mode ranging from 0-255. The camera will automatically switch from night mode to day mode based on the setup sensitivity. The default value is 35.

### Light Board Control

**Mode:** Select a mode (OFF, Manual, Auto) from the drop-down list. The default Light Board Control mode is OFF.

**Brightness:** You can configure the brightness for **Manual** Light Board Control Mode.

### Advanced Settings

**TWDR (True Wide Dynamic Range):** The WDR function provides clearer images when both of the very bright and dark areas simultaneously appear on the camera view. There are four value options: OFF, Low, Mid and High. Note that when WDR is enabled, some parts of the image may appear solarized. This is normal for WDR, and is not a camera malfunction. The default TWDR mode is OFF.

**3DNR (3D Noise Reduction):** Noise Reduction limits the amount of digital “video noise” that is usually found in any video stream, and helps to reduce file size. There are five value options: OFF, Low, Mid, Mid-High and High. The default 3DNR mode is Low.

**Defogging:** The Defog function makes the subject appear clearer when the surrounding area of the subject is foggy and low contrast. There are four value options: OFF, Low, Mid and High. The default defogging mode is OFF.

**Slow Shutter:** Select from OFF or ON.

---

**Note:** Modifying the TWDR mode will cause the system to reboot automatically. Please create a new network connection to the IP camera when the reboot is complete.

---

### Exposure Control

**Mode:** Select a mode from Auto or Manual. The default Exposure mode is Auto.

- **Auto(AGC):** Selecting Auto for the camera to automatically adjust the Shutter based on the measured light level. You can further configure the AGC value.
- **Manual:** Select this option to manually set up the Shutter value.

**AGC:** For **Auto(AGC)** Exposure mode, you can further configure the **AGC** value. Select the Auto Gain Control level from Low to High. The lower the AGC level, the lower the video signal and the noise. The higher the AGC level, the better the sensitivity under low illumination, while the noise will be more obvious. The default AGC level is Mid-High.

**Shutter:** For **Manual** Exposure mode, you can further configure the **Shutter** value. If enabled, this setting lets you set the shutter speed yourself (measured in fractions of a second).

### Aperture

**Lens:** Select a mode from Manual or Semiautomatic. The default Iris mode is Semiautomatic.

**Note:** The **Aperture** function is only available for **EDN288M/368M/468M** and **EZN288M/368M/468M**.

### Gamma

**Gamma:** Users can use this field to optimize video quality of the monitor. Choose CURVE\_1\_6, CURVE\_1\_8, CURVE\_2\_0 or CURVE\_2\_2 from the drop down list. The darker the environment is, the higher Gamma value you should choose. The default Gamma mode is CURVE\_2\_0.

**Flikerless:** Choose between OFF, 50HZ or 60HZ. The default Flikerless mode is OFF.

After complete the settings, click Save to apply the changes.



7.2.3. Image

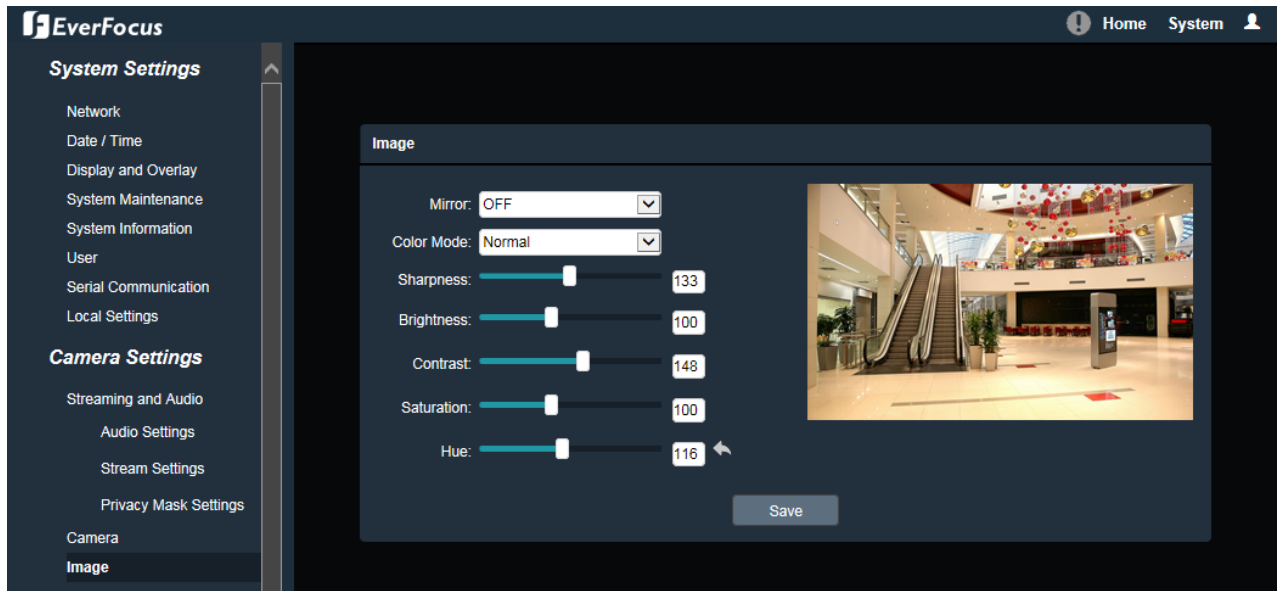

**Mirror:** Select a mirror mode from OFF, Horizontal Mirror, Vertical Mirror, 180 degree Rotation, 90 degree Rotation or 270 degree Rotation. The default Mirror mode is Close.

- **Horizontal Mirror:** The image will be rotated horizontally around a vertical axis.
- **Vertical Mirror:** The image will be rotated vertically around a horizontal axis.
- **180 degree Rotation:** The image will be rotated 180 degree.
- **90 degree Rotation:** The image will be rotated 90 degree.
- **270 degree Rotation:** The image will be rotated 270 degree.

**Note:** Set up 90 / 180 / 270 degree rotation will cause the system to reboot automatically. Please create a new network connection to the IP camera when the reboot is complete.

**Color Mode:** Select a color mode from Normal, Bright or Nature. The default color mode is Normal.

**Sharpness:** Slide the bar to adjust the sharpness.

**Brightness:** Slide the bar to adjust the brightness.

**Contrast:** Slide the bar to adjust the contrast.

**Saturation:** Slide the bar to adjust the saturation.

**Hue:** Slide the bar to adjust the hue.

Click the **Default** button  to return the color settings (Bright, Contrast, Saturation and Hue) to the default value.



After complete the settings, click **Save** to apply the changes.

### 7.3. Event Settings

You can set up the Motion Detection event or Tampering Detection event to automatically notify the users when an event occurs.

#### 7.3.1. Event

##### 7.3.1.1. Motion Settings

Use this page to configure the area in which motion will be detected, and set up schedules to active alarm functions. When a motion is detected by the camera, the alarm icon  at the top of the Live View window will turn red and blink  to alert the user. Up to four Motion areas can be configured.

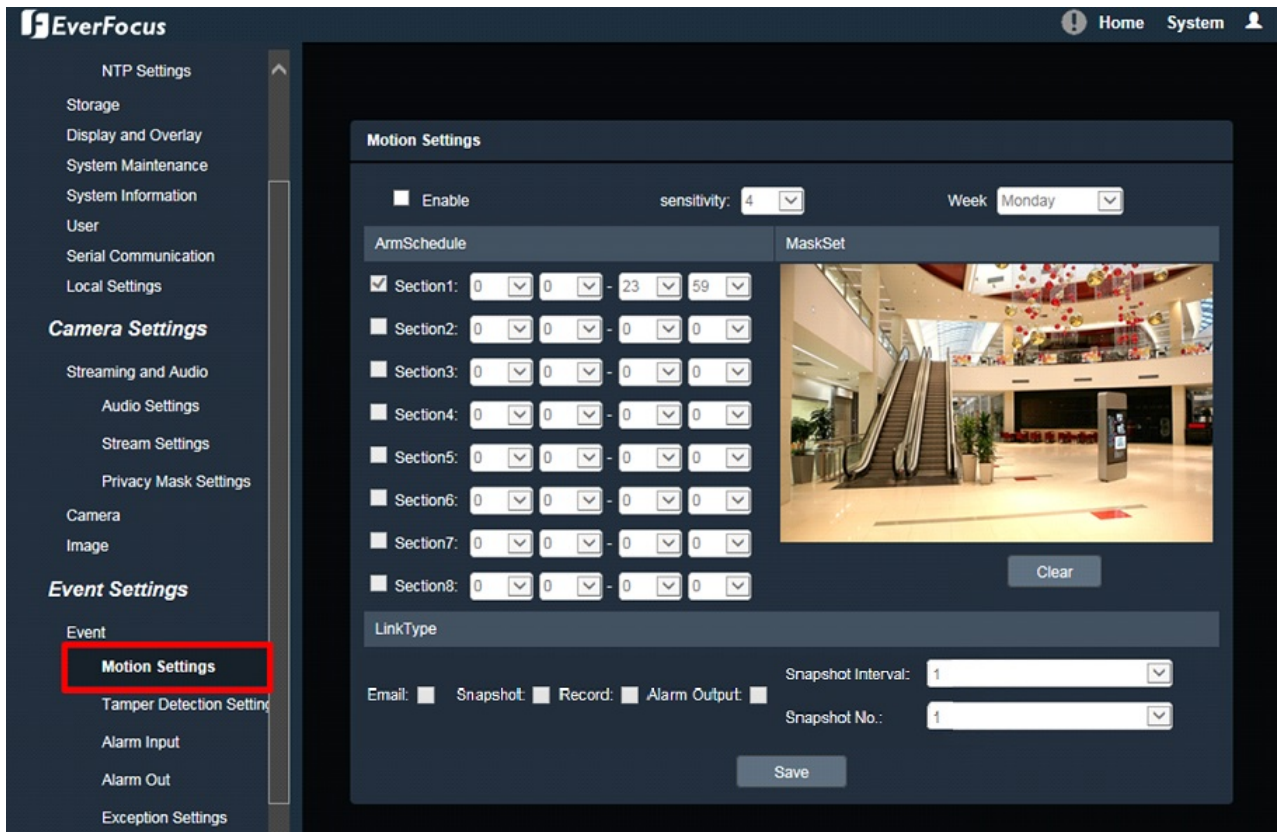

To set up a Motion Detection area:

1. Check the **Enable** box to enable the Motion Detection function. Select a value from the drop-down list to set the sensitivity of the Motion Detection.
2. Select a day (Monday ~ Sunday) from the **Week** drop-down list to configure the schedule.

3. Set up schedules to active the alarm functions and send alarm notification. Check the box of the desired section to configure the schedule, and select a start / end time from the drop-down list for the section.
4. On the preview window, click and drag to draw the desired Motion Detect area, the area will be marked in red.
5. You can remove the configured Motion Detection area by clicking the **Clear** button.
6. Set up event reactions for the Motion Detection function. Check the box of the desired reaction (Email, Snapshot, Record or Alarm output) to link with the function.

**Email:** Check the box to enable transmitting the alarm notification to the mail server. To configure Email settings, see *7.3.2.1 Email Settings*.

**Snapshot:** Check the box to enable taking snapshots to the micro SD Card when an event occurs. You can further configure the Snapshot settings including **Snapshot Interval** and **Snapshot No.**. For example, if you set up the **Snapshot Interval** to 5 and **Snapshot No.** to 3, system will take 3 snapshots every 5 seconds.



**Record:** Check the box to enable recording to the micro SD Card when an event occurs.

**Alarm Output:** Check the box to enable triggering the external alarm device.

After complete the settings, click **Save** to apply the settings.

**Note:** The Snapshot and Record settings are only functional if the micro SD Card has been inserted in the camera's micro SD card slot.

7.3.1.2. Tamper Detection Settings

Use this page to configure the area in which tampering will be detected and set up schedules to active alarm functions. When a tampering is detected by the camera, the alarm icon  at the top of the Live View window will turn red and blink  to alert the user.

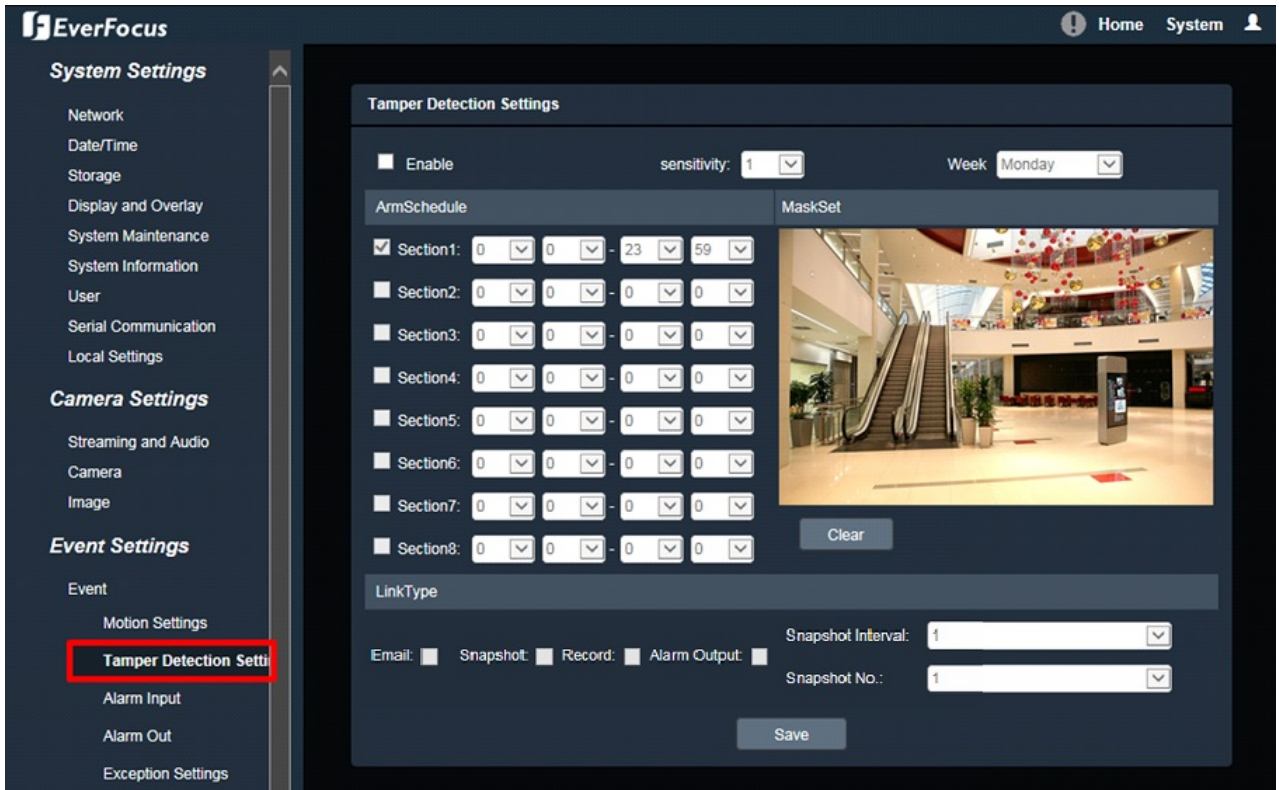

To set up a Tampering Detection area:

1. Check the **Enable** box to enable the Tampering Detection function. Select a value from the drop-down list to set the sensitivity of the Tampering Detection.
2. Select a day (Monday ~ Sunday) from the **Week** drop-down list to configure the schedule.
3. Set up schedules to active the alarm functions and send alarm notification. Check the box of the desired section to configure the schedule, and select a start / end time from the drop-down list for the section.
4. On the preview window, click and drag to draw the desired Tampering Detection area, the area will be marked in red.
5. You can remove the configured Tampering Detection area by clicking the **Clear** button.
6. Set up event reactions for the Tampering Detection function. Check the box of the desired reaction (Email, Snapshot, Record or Alarm output) to link with the function.

**Email:** Check the box to enable transmitting the alarm notification to the mail server. To configure Email settings, see 7.3.2.1 *Email Settings*.

**Snapshot:** Check the box to enable taking snapshots to the micro SD Card when an event occurs. You can further configure the Snapshot settings including **Snapshot Interval** and **Snapshot No.**. For example, if you set up the **Snapshot Interval** to 5 and **Snapshot No.** to 3, system will take 3 snapshots every 5 seconds.



**Record:** Check the box to enable recording to the micro SD Card when an event occurs.

**Alarm Output:** Check the box to enable triggering the external alarm device.

After complete the settings, click **Save** to apply the settings.

**Note:** The Snapshot and Record settings are only functional if the micro SD Card has been inserted in the camera's micro SD card slot.

### 7.3.1.3. Alarm Input

Use this page to configure the alarm input channel in which event will be triggered and set up schedules to active alarm functions. When an event is triggered by the alarm input, the alarm icon  at the top of the Live View window will turn red and blink  to alert the user.

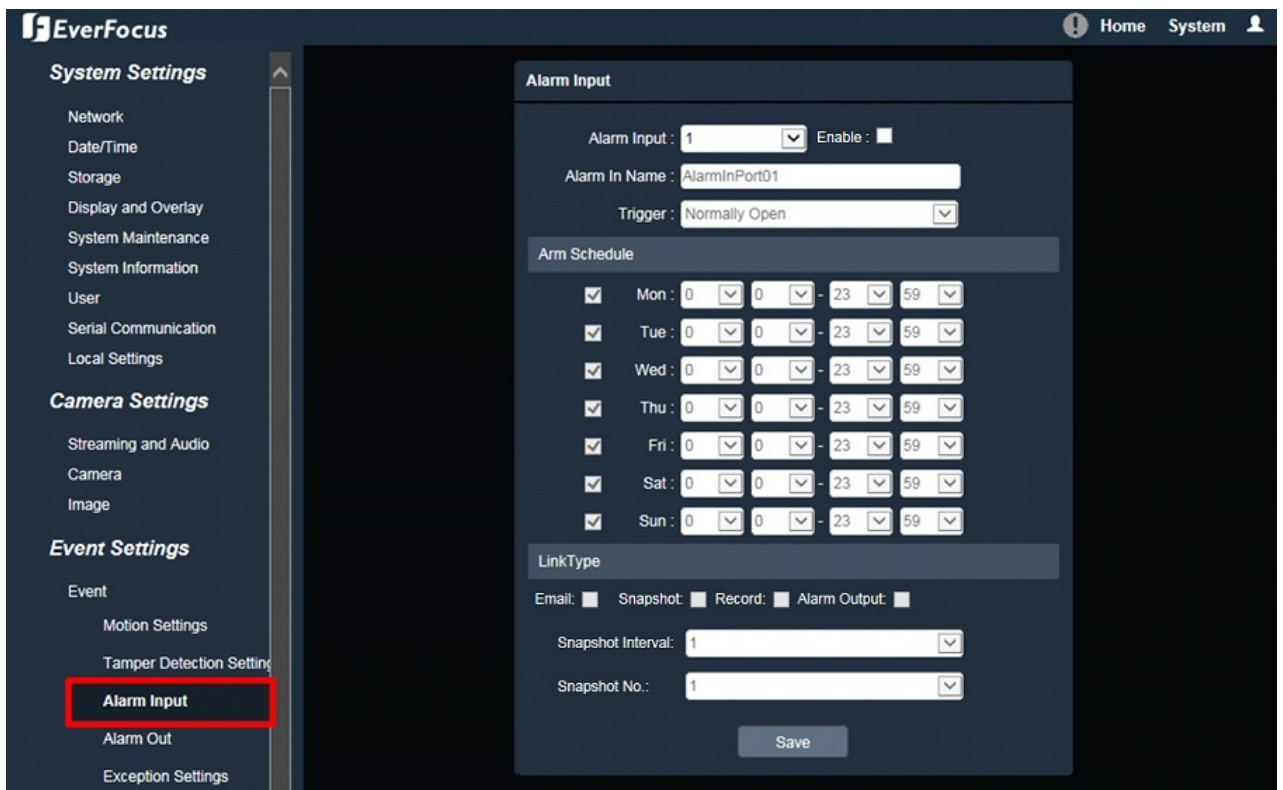

To set up the Alarm Input function:

1. Select a camera's Alarm Input channel from the drop-down list and check the **Enable** box to enable this channel. After enabling this channel, you can further configure the Alarm Input schedules and event reactions.
2. Enter a name for the Alarm Input channel in the **Alarm Input Title** field (the name will show up in the event notifications and logs) and select Normally Open or Normally Close from the **Trigger Type** drop-down list.
3. Set up schedules to active the alarm functions and send alarm notification. Check the box of the desired day (Monday ~ Sunday) to configure the schedule, and select a start / end time from the drop-down list for each day.
4. Set up event reactions for the Alarm Input channel. Check the box of the desired reaction (Email, Snapshot, Record or Alarm output) to link with the function.

**Email:** Check the box to enable transmitting the alarm notification to the mail server. To configure Email settings, see *7.3.2.1 Email Settings*.

**Snapshot:** Check the box to enable taking snapshots to the micro SD Card when an event occurs. You can further configure the Snapshot settings including **Snapshot Interval** and **Snapshot No.**. For example, if you set up the **Snapshot Interval** to 5 and **Snapshot No.** to 3, system will take 3 snapshots every 5 seconds.

**Record:** Check the box to enable recording to the micro SD Card when an event occurs.

**Alarm Output:** Check the box to enable triggering the external alarm device.

After complete the settings, click **Save** to apply the settings.

**Note:** The Snapshot and Record settings are only functional if the micro SD Card has been inserted in the camera's micro SD card slot.

**7.3.1.4. Alarm Output**

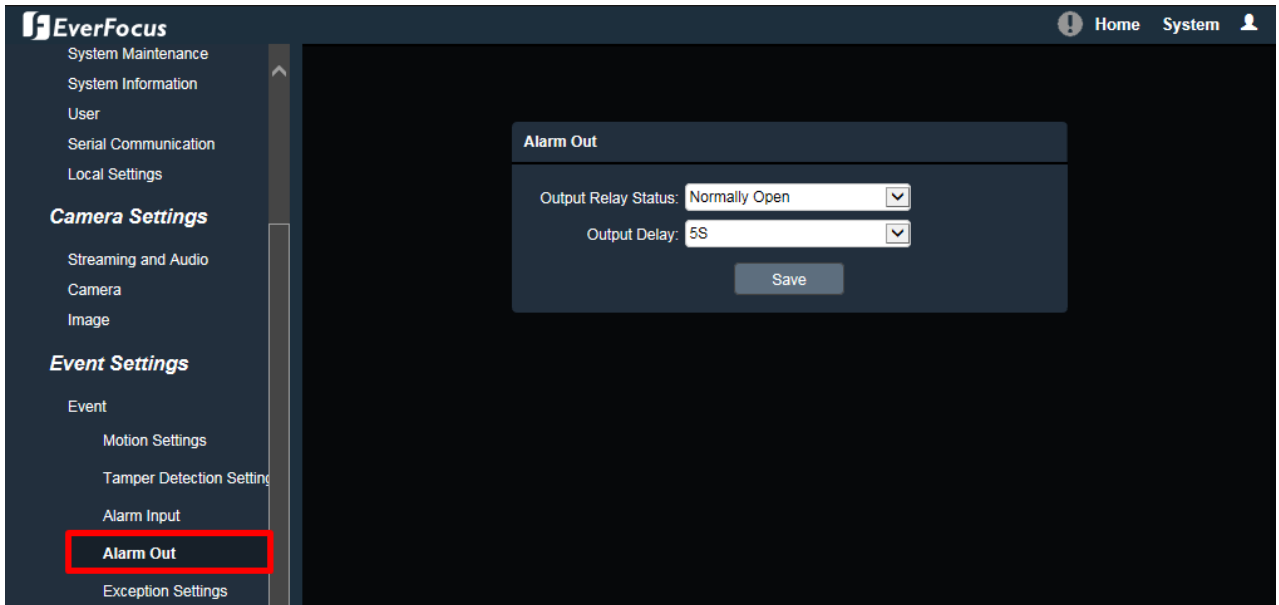

**Output Relay Status:** Select Normally Open or Normally Close from the drop-down list.

**Output Delay:** Select the duration (5 seconds - 10 minutes) for the buffer. This will determine the length of time after the event trigger moment that the external alarm device will keep alarming.

After complete the settings, click **Save** to apply the settings.

**7.3.1.5. Exception Settings**

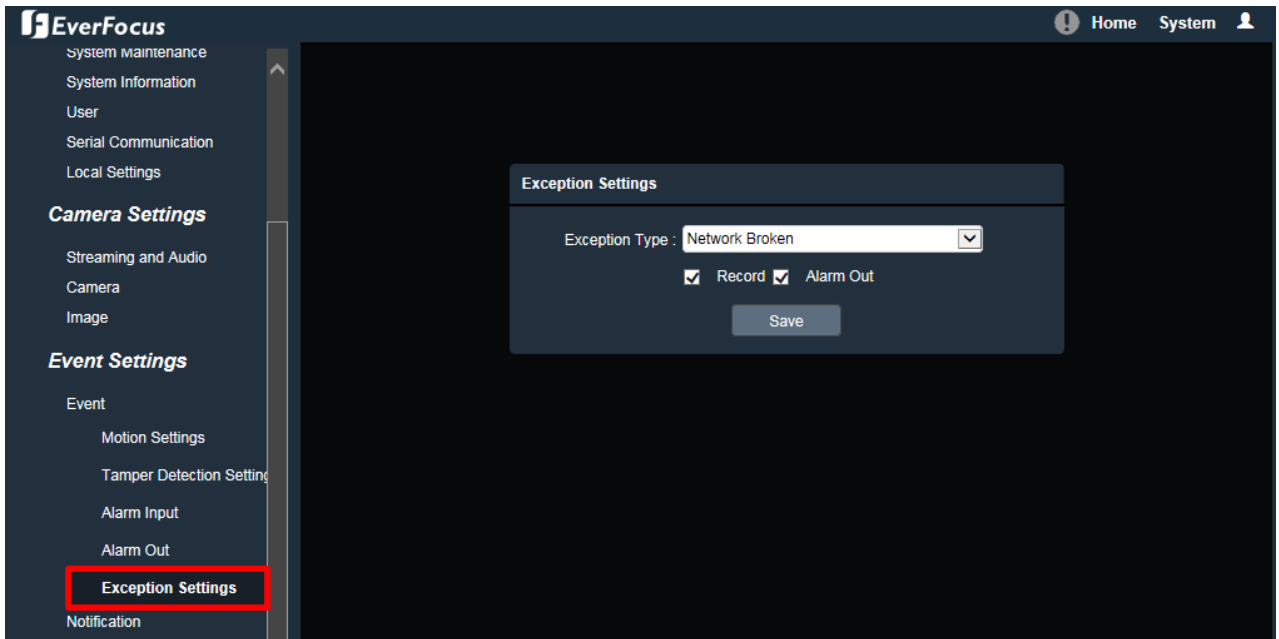

**Exception Type:** Select an exception type from Network Broken, IP Address Conflict or Illegal Access.

**Record:** Check the box to enable recording to the micro SD Card when an event occurs.

**Alarm Output:** Check the box to enable triggering the external alarm device.

After complete the settings, click **Save** to apply the settings.

**Note:** The Record setting is only functional if the micro SD Card has been inserted to the camera’s micro SD card slot.



7.3.2. Notification

7.3.2.1. Email Settings

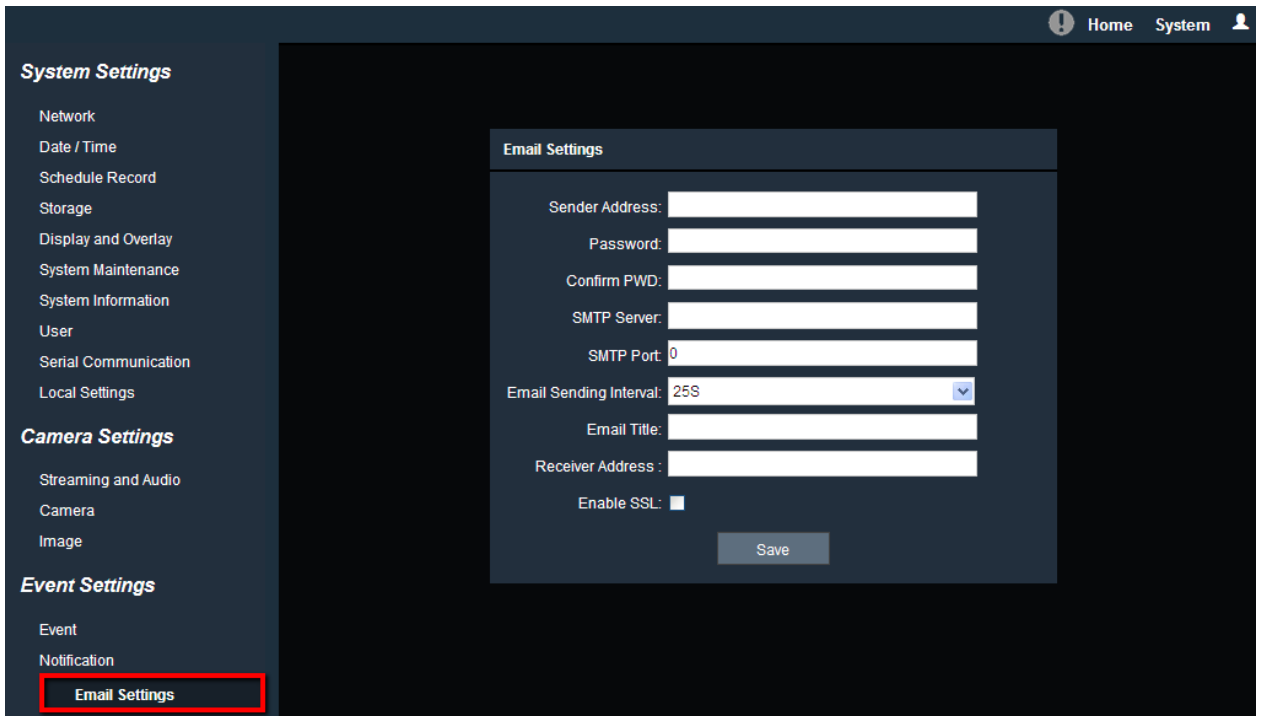

**Sender Address:** Input the sender’s e-mail address, so that the receiver can recognize the sender when an event message is received.

**Password:** Input the user’s login password if the SMTP server requires authentication.

**Confirm PWD:** Type the password again to confirm it.

**SMTP Server:** Enter the IP address or the host name of the SMTP server used to send e-mails.

**SMTP Port:** Enter the port number for SMTP.

**Email Sending Interval:** Input the interval time for sending e-mail notification.

**Email Title:** Type the e-mail title.

**Receiver Address:** Input the e-mail addresses for receiving an e-mail message when events occur. Currently only one receiver address can be configured.

After complete the settings, click **Save** to apply the settings.

## 7.4. Search and Play

You can remotely play back the recordings stored in the on-camera micro SD card on the Playback page, or play back the snapshots / recordings stored in the computer on the File page.

### 7.4.1. Playback

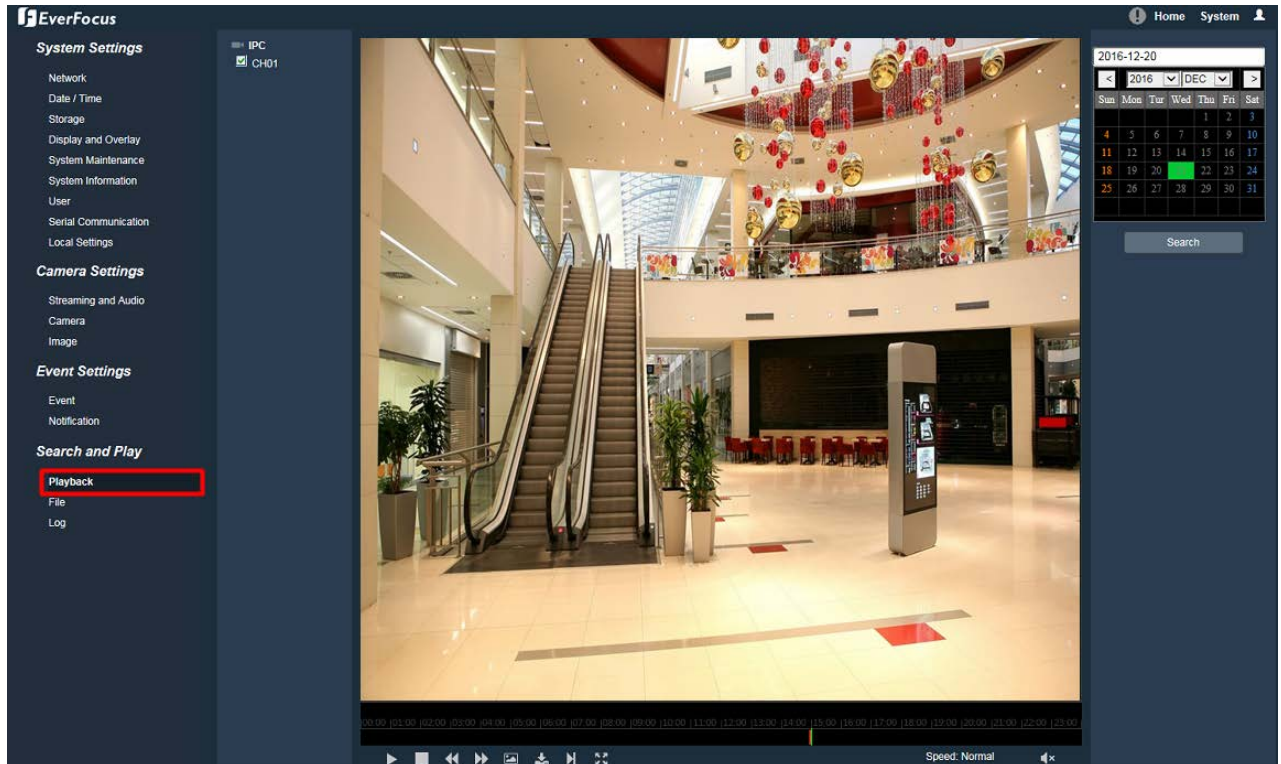

Playback is designed as a quick way to check recent event recordings in the on-camera micro SD card. This page is only available when a micro SD card has been inserted to the SD card slot.



To search and then play back the recording:

Check the **CH01** box to select the IP camera on the left-side panel, and then select the date you want to search on the right-side panel. Click **Search** to get your search results. Double-click on the Time Bar to play back from the specified time, or click the **Start** to play back from the start.



**Start / Pause:** Click  to play the recording file. Click  to pause playing back.

**Stop:** Click  to stop playing back.

**Slow:** Click  to slow down the playback speed (switch between 1/2, 1/4, 1/8 and 1/16).

**Fast:** Click  to speed up the playback speed (switch between 2, 4, 8 and 16).

**Capture:** Click  to take a snapshot.

**Backup:** Click  and a Video Download window will pop up.

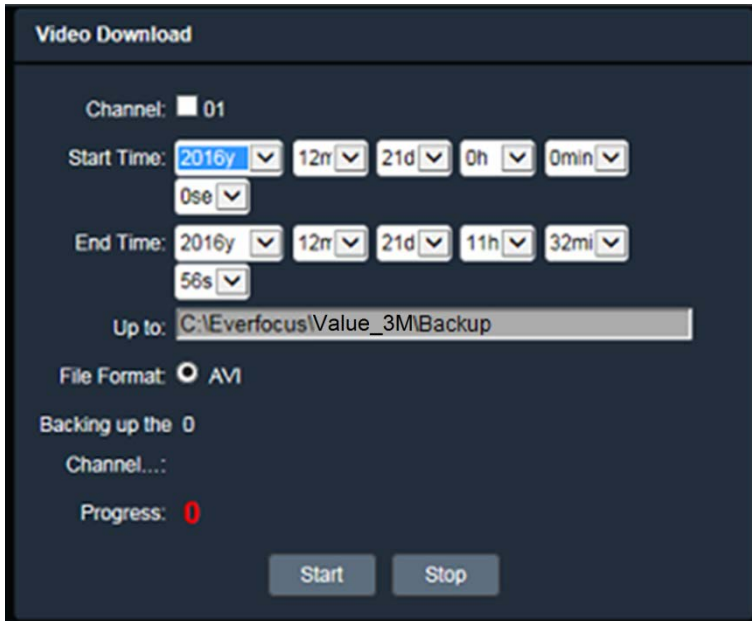

To back up the recording:

1. Check the **01** box to select the IP camera
2. Select the **Start/End** Time for the recordings you want to back up.
3. Specify the storage path for the backup files in the **Up to** column.
4. Click **Start** to download the recording files; click **Stop** to stop downloading.

**Frame Play:** Click  to play the recording file frame by frame.

**Full Screen:** Click  to display the current recordings in full screen.

**Speed:** Display the current playback speed.

**Voice:** Click  to adjust the volume or switch the sound on / off for of the recording.

**Note:** The Playback page is only accessible if the micro SD Card has been inserted in the camera's micro SD card slot.

### 7.4.2. File

File is a tool to check all the snapshots, recordings and backup files in the on-camera micro SD card or the local storage.

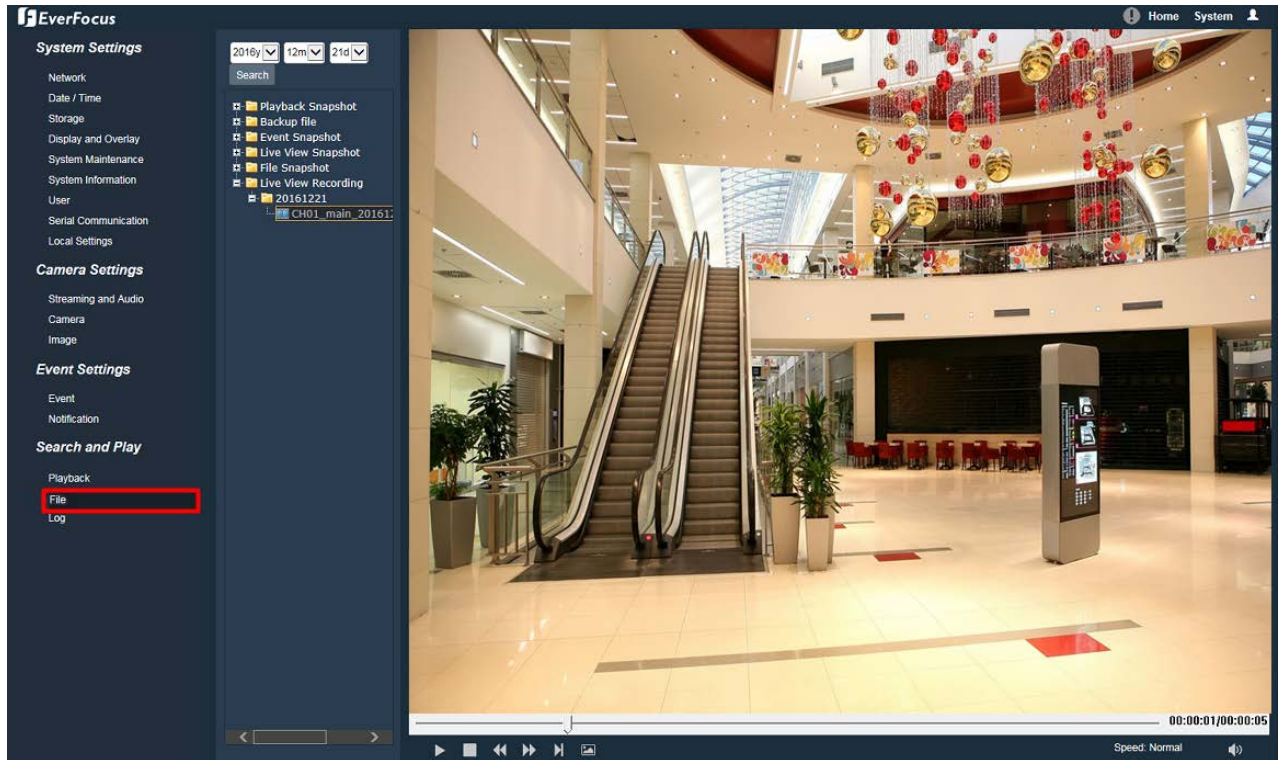

To search and then view the snapshot / recording file:

1. On the left-side panel, select the date you want to search and then click **Search**.
2. Click the  node of the desired file type to expand the sub-folder (date folder).

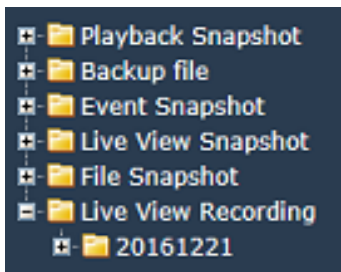

3. Click the  node of the desired date folder to list all files captured or recorded on this date.



4. Double-click on the file to display it.

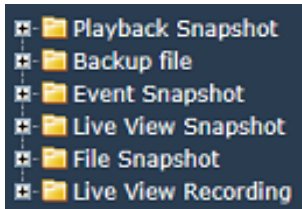

**Playback Snapshot:** Click to list all snapshots captured in the **Playback** page.

**Backup file:** Click to list all recording files backed up in the **Playback** page.



**Event Snapshot:** Click to list all snapshots captured by the triggering of Events.

**Live View Snapshot:** Click to list all snapshots captured in the **Home** page (Live View window).

**File Snapshot:** Click to list all snapshots captured in this (**File**) page.

**Live View Recording:** Click to list all recordings recorded in the **Home** page (Live View window).



**Start / Pause:** Click  to play the file. Click  to pause playing.

**Stop:** Click  to stop playing.

**Slow:** Click  to slow down the play speed (switch between 1/2, 1/4, 1/8 and 1/16)

**Fast:** Click  to speed up the play speed (switch between 2, 4, 8 and 16)

**Frame Play:** Click  to play the recording file frame by frame.

**Capture:** Click  to take a snapshot.

**Speed:** Display the current speed.

**Voice:** Click  to adjust the volume or switch the sound on / off for of the recording file.

To change the storage path, see 7.1.9 Local Settings.

---

**Note:** The Playback Capture / Backup / Linkage Capture folders are only accessible if the micro SD Card has been inserted in the camera's micro SD card slot.

---

### 7.4.3. View Log

The screenshot shows the EverFocus web interface. On the left, there is a sidebar with navigation menus: **System Settings** (Network, Date / Time, Storage, Display and Overlay, System Maintenance, System Information, User, Serial Communication, Local Settings), **Camera Settings** (Streaming and Audio, Audio Settings, Stream Settings, Privacy Mask Settings, Camera, Image), **Event Settings** (Event, Notification), and **Search and Play** (File, **Log**). The main content area is titled 'Log' and contains a search form with 'Log Type' set to 'All', 'Start Time' as '2016-12-10', 'End Time' as '2016-12-15', and 'No. per Page' set to '22'. A 'Search' button is below the form. To the right is a table of log entries:

Index	Log Time	Log Type	Log Theme	Ch	User Address
1	2016-12-15 08:01:01	Additional Information	Set up NTP Application Parameters	1	192.168.31.100
2	2016-12-15 08:00:44	Additional Information	Set up Device Time	1	192.168.31.100
3	2016-12-15 16:35:43	Additional Information	Set up NTP Application Parameters	1	192.168.31.100
4	2016-12-15 16:35:36	Additional Information	Set up Device Time	1	192.168.31.100
5	2016-12-15 08:31:31	Operation	Remotely Logoff	1	
6	2016-12-15 08:30:19	Operation	Remotely Logoff	1	
7	2016-12-15 08:29:30	Operation	Remotely Logoff	1	
8	2016-12-15 08:28:54	Operation	Remotely Upgrade	1	
9	2016-12-15 06:29:41	Operation	Remotely Logoff	1	
10	2016-12-15 06:22:16	Operation	Remotely Logoff	1	
11	2016-12-15 06:21:42	Operation	Remotely Reboot	1	192.168.31.100
12	2016-12-15 06:21:41	Additional Information	Set up SENSOR	1	192.168.31.100
13	2016-12-15 06:21:40	Additional Information	Set up OSD Image Parameters	1	192.168.31.100
14	2016-12-15 06:19:29	Operation	Remotely Logoff	1	
15	2016-12-14 02:03:26	Operation	Remotely Logoff	1	
16	2016-12-13 09:42:33	Operation	Remotely Logoff	1	
17	2016-12-12 20:16:30	Operation	Remotely Logoff	1	
18	2016-12-12 19:57:53	Additional Information	Set up Multi-card Parameters	1	
19	2016-12-12 19:57:52	Operation	Remotely Logoff	1	
20	2016-12-12 19:57:42	Operation	Remotely Reboot	1	192.168.31.44
21	2016-12-12 19:51:51	Additional Information	undefined	1	192.168.31.44
22	2016-12-12 19:51:21	Operation	Remotely Logoff	1	

At the bottom right of the table, it says 'Total 686 Records Current 1 Page Next Page Last Page Go to 1 Page'.

To search the system log:

1. On the left-side panel, click on the **Main Type** drop-down list to select a log type from All, Alarm, Exception Settings, Operation and Setup.
2. Click on the **Start/End Time** column to bring up the calendar and then select a start/end date.
3. Click the **Search** button, the search result will be displayed in the right part of the page.
4. You can specify how many logs to display on each page in the **No. per Page** column.

## 8. Upgrading Firmware Using IP Utility

You can upgrade the Firmware using the **IP Utility** software included in the software CD. The IP Utility can also be downloaded from EverFocus'

Website: [http://www.everfocus.com.tw/HQ/Support/DownloadCenter\\_p1.aspx](http://www.everfocus.com.tw/HQ/Support/DownloadCenter_p1.aspx) (Support > Download Center > Keyword Search: IP Utility). Please connect the IP camera on the same LAN of your computer.

1. Install and then start the IPU program , the following IPU window appears. The IPU will automatically search the IP devices connected in the LAN.

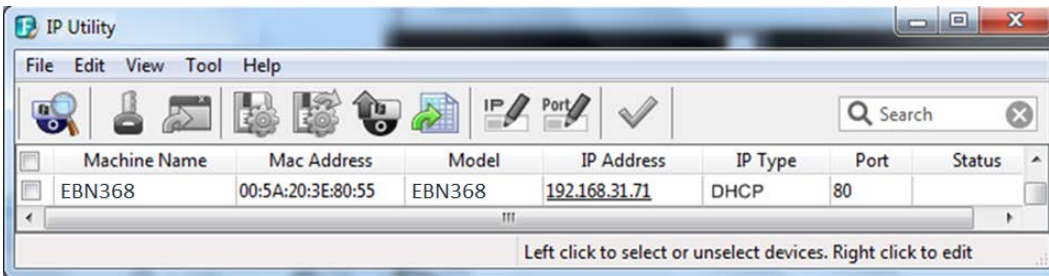

2. Log in the camera by checking the desired model and then click the **Log in**  icon. The Log in dialog box appears.

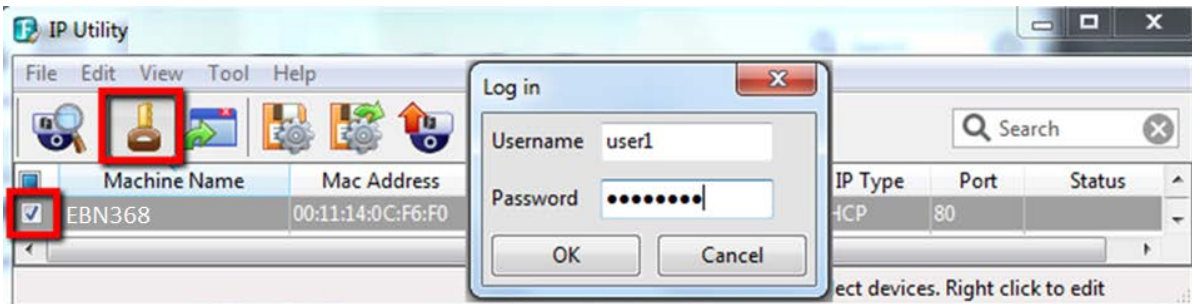

3. Type the Username and Password. Click the **OK** button, the **Login** status displays.

Machine Name	Mac Address	Model	IP Address	IP Type	Port	Status
<input checked="" type="checkbox"/> EBN368	00:11:14:12:30:A4	EBN368	192.168.31.67	DHCP	80	Login

**Note:**

1. The default user ID is **user1** and the default password is **11111111**
2. If you select more than one camera that has the same user ID / password, you will be able to log in several cameras at once.
3. Up to 10 cameras can be simultaneously upgraded to the latest firmware. If you connect the cameras to a PoE switch, please make sure the Power Consumption of the PoE switch is sufficient.

- Click the **Upgrade Firmware** button , a browsing window appears.

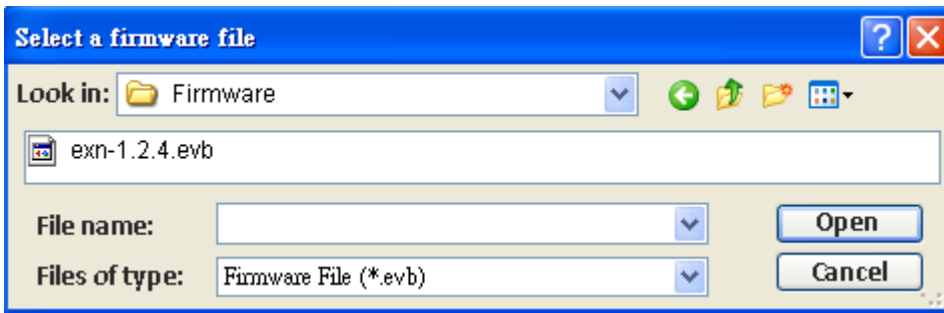

- Select the **firmware file (.evb)** and then click **Open**. The IPU will automatically upgrade the firmware. The camera will reboot once the upgrade process is complete.

	Machine Name	Model	IP Address	IP Type	Port	Status
<input checked="" type="checkbox"/>	EBN368	EBN368	<a href="#">192.168.31.215</a>	Static IP	80	Success



## 9. Specifications

Model	EBN288/ 368/468	EDN288M /368M/468M	EMN468/ 468W	EZN288/ 368/468	EZN288M/ 368M/468M
<b>Camera</b>					
Megapixel	<b>288 Series:</b> 2MP ; <b>368 Series :</b> 3MP ; <b>468 Series :</b> 4MP				
Pickup Device	Sony Progressive Scan CMOS sensor				
Min. Illuminations	<b>288/268 Series:</b> <u>Color:</u> 0.05Lux @ F1.4; <u>B/W:</u> 0.005Lux @ F1.4 <b>468 Series:</b> <u>Color:</u> 0.5Lux @ F1.4; <u>B/W:</u> 0.2Lux @ F1.4				
Day/Night	True Day/Night with ICR				
Shutter Time	1/25 ~ 1/10,000				
Scanning System	NTSC / PAL				
WDR	<b>288/268 Series:</b> T-WDR (120dB) <b>468 Series:</b> D-WDR				
AGC	Yes				
AWB	Yes				
<b>Lens</b>					
Lens	<b>3.6mm fixed lens:</b> EBN288/368/468; EMN468; EZN288/368/468 <b>Motorized 2.8-12mm lens:</b> EDN288M/368M/468M; EZN288M/368M/468M <b>2.2mm lens FOV 152°(H) x 83°(V) x 173°(D):</b> EMN468W				
Lens Angle of View	-	Horizontal 150°, Vertical 75°	-	Horizontal 360°, Vertical 90°	Horizontal 360°, Vertical 90°
Day/Night	True Day/Night with ICR (EMN468W does not feature this function)				
IR Distance	30m / 100ft.		10m / 33ft.*	30m / 100ft.	
IR LED Quantity	18	12	6*	15	3 (High Power IR LEDs)
IRIS	Fixed Iris				
<b>Video</b>					
Video Compression	H.265 / H.264				
Max. Video Resolution	<b>288 Series:</b> 1920 x 1080 ; <b>368 Series :</b> 2048 x 1536 ; <b>468 Series :</b> 2592 x 1520				
Frame Rate	25fps / 30fps (PAL / NTSC)				
S/N Ratio	<b>288/268 Series:</b> ≥ 50dB (AGC OFF) <b>468 Series:</b> ≥ 35dB (AGC OFF)				
Image Settings	Contrast, Brightness, Saturation, Sharpness, Mirroring of Images				
<b>Audio</b>					
Audio Compression	G.711A / 64Kbps / Two-way audio**				
Audio Input / Output	1 In (Line-in 3.5mm stereo TRS jack)** 1 Out (Line-out 3.5mm stereo TRS jack)**				

Model	EBN288/ 368/468	EDN288M /368M/468M	EMN468/ 468W	EZN288/ 368/468	EZN288M/ 368M/468M
<b>Network</b>					
Interface	RJ-45 10M/100M adaptive				
Supported Protocols	TCP/IP, UDP, HTTP, DHCP, RTSP, DDNS, NTP, PPPOE, UPNP, SMTP, ONVIF				
Connector	Power	12VDC, PoE			
	Ethernet	RJ-45			
<b>Event / Notification</b>					
Event Trigger	Motion Detection				
Notification	Email Notification				
<b>General</b>					
Storage	-	Micro SD / SDHC / SDXC slot (Max. 128G, up to class 10)			
RS-485	RS-485 x 1 (reserved)**				
Alarm Input / Output	2 / 1**				
Video Output	Video Output cable**				
Power Supply	12VDC / PoE (IEEE802.3af Class 3)				
Max. Power Consumption (IR LEDs on)	12VDC 5.2W / PoE 5.8W	12VDC 4.5W / PoE 4.9W	EMN468: 12VDC/PoE: 7W EMN468W: 12VDC/PoE: 6W	12VDC 3.5W / PoE 3.9W	12VDC 7.4W / PoE 8.2W
Water Proof	IP66				
Humidity	0% ~ 90% not condensing				
Operating Temperature	-10°C ~ 50°C / 14°F ~ 122°F				
Dimensions	120 x 95mm/ 4.72" x 3.74"	117 x 86mm / 4.61" x 3.39"	117 x 65mm / 4.61" x 2.60"	186 x 71mm / 7.32" x 2.80"	263 x 93mm / 10.35" x 3.66"
Weight	740g / 1.63lb	660g / 1.46lb	EMN468: 516g / 1.14lb EMN468W: 514g / 1.13lb	600g / 1.32lb	957g / 2.11lb
Certificates	CE / FCC				

\* EMN468W does not feature IR LEDs.

\*\*Economic models do not include the feature

## 10. Troubleshooting

### Low Frame Rate

If the frame rate is lower than expected, follow the steps below to fix the problem.

1. Reduce the number of applications running on your PC.
2. Limit the number of users that access camera live view.
3. Check whether the network bandwidth is sufficient.
4. Lower the video resolution.
5. Lower the camera Bit Rate by configuring Constant Bit Rate or Variable Bit Rate (see 7.2.1 Streaming and Audio).

## Appendix

### A. Enabling the Multicast Function

The Multicast Function is a technique for one-to-many communication over an IP infrastructure in a network that is designed to share IP camera loading and reduce network bandwidth. Note that for this function to work, the router / switch must support multicast function.

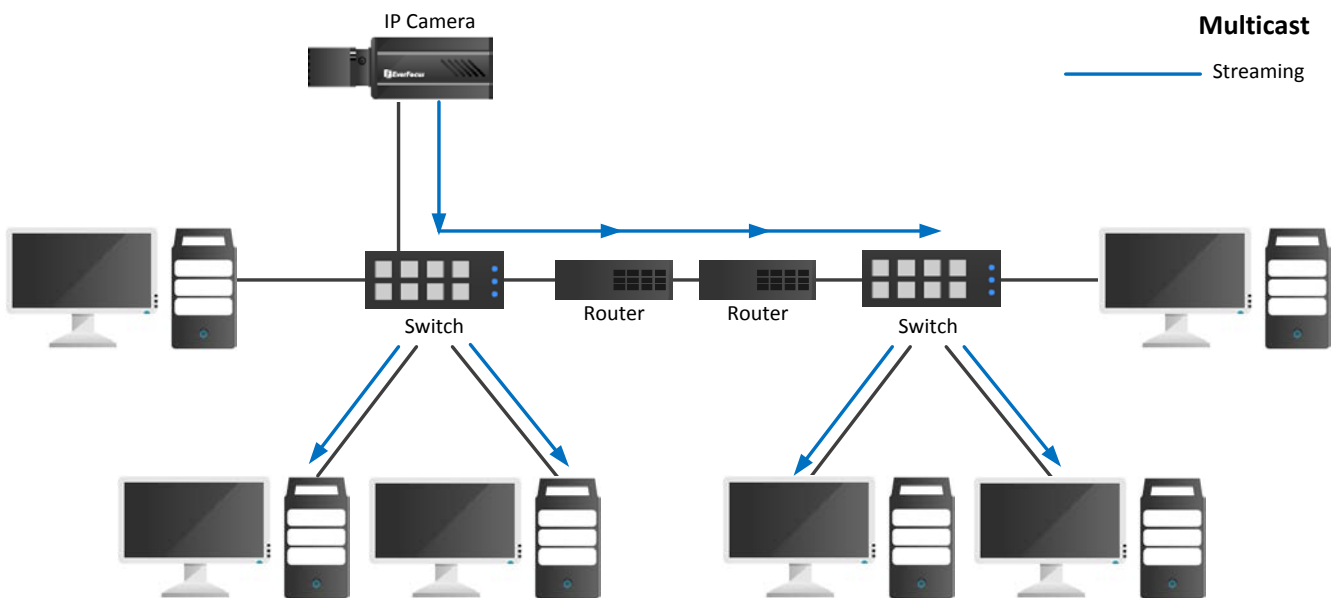

#### To enable the Multicast Function:

1. Complete the installation of the IP cameras, routers / switches and computers (refer to diagram above).
2. Access to the Web UI of the IP camera to enable the Multicast function. Click the **Save** button to save the setting. (System > System Settings > Network > Multicast Settings > **Enable Multicast**)

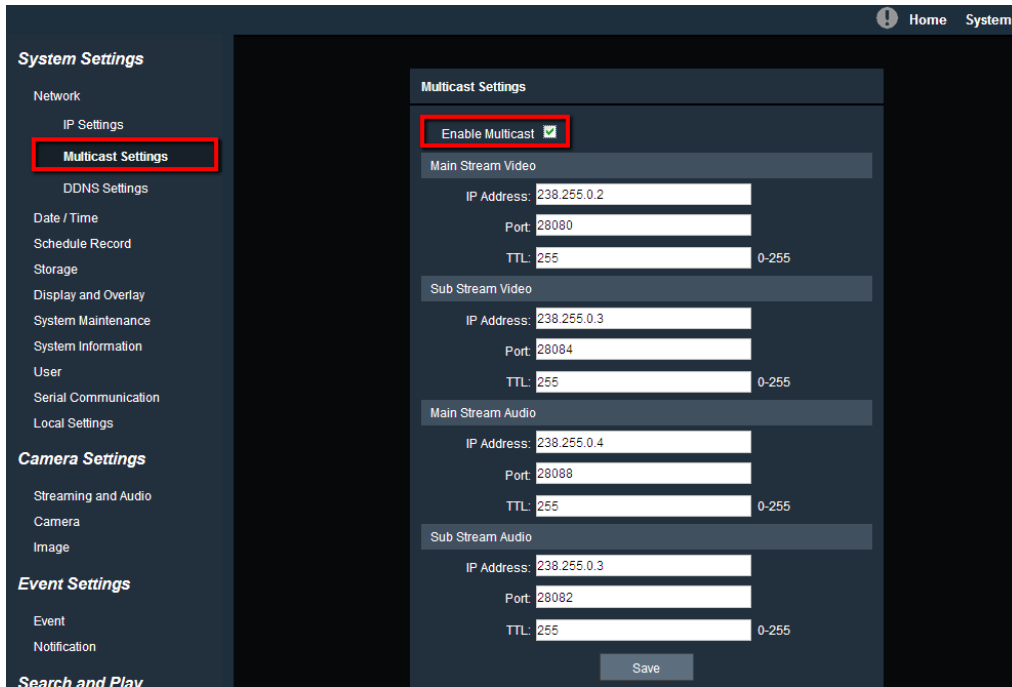

- Go to the setting page of the router / switch to enable the Multicast function. Here we use a D-Link DIR655 router and EverFocus 24-port switch for example.

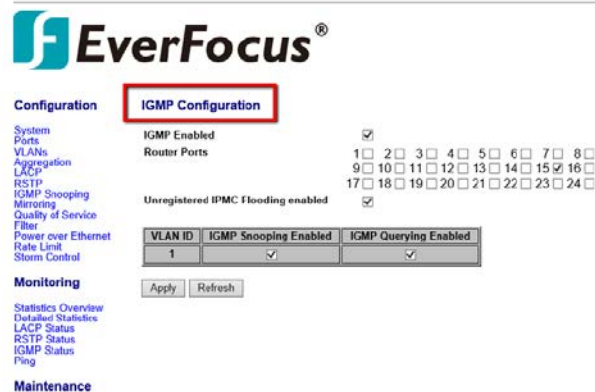
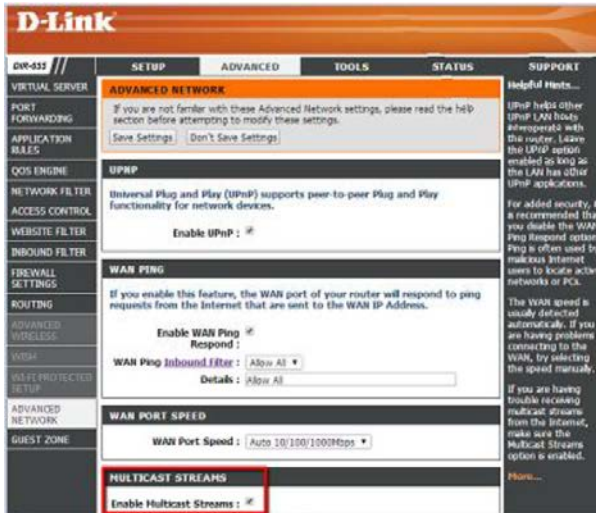

- The Multicast function setup is now complete.

## B. RTSP URL Syntax

Following is the RTSP URL syntax of EverFocus' IP cameras.

```
rtsp://[device-ip-address]/ch1_[main]
```

\* [device-ip-address] is the IP address of the IP camera

\* [main] is for Main Stream; [sub] is for Sub Stream

For example, if the IP address of the IP camera is 192.168.37.55, the RTSP URL (main stream / sub stream) of this IP camera will be:

Main Stream:

```
rtsp://192.168.37.55/ch1_main
```

Sub Stream:

```
rtsp://192.168.37.55/ch1_sub
```

**Note:** If you have difficulty getting the live view image, please reduce the number of clients accessing the IP camera.

**C. Setting up Port Forwarding Function**

IP Camera port forwarding can be used when users need to access a certain IP camera from outside of the local network where the IP camera is connected to.

To enable the IP camera port forwarding function, you have to configure the port forwarding settings both on the IP camera and the router (UPnP-enabled). Please follow the steps below:

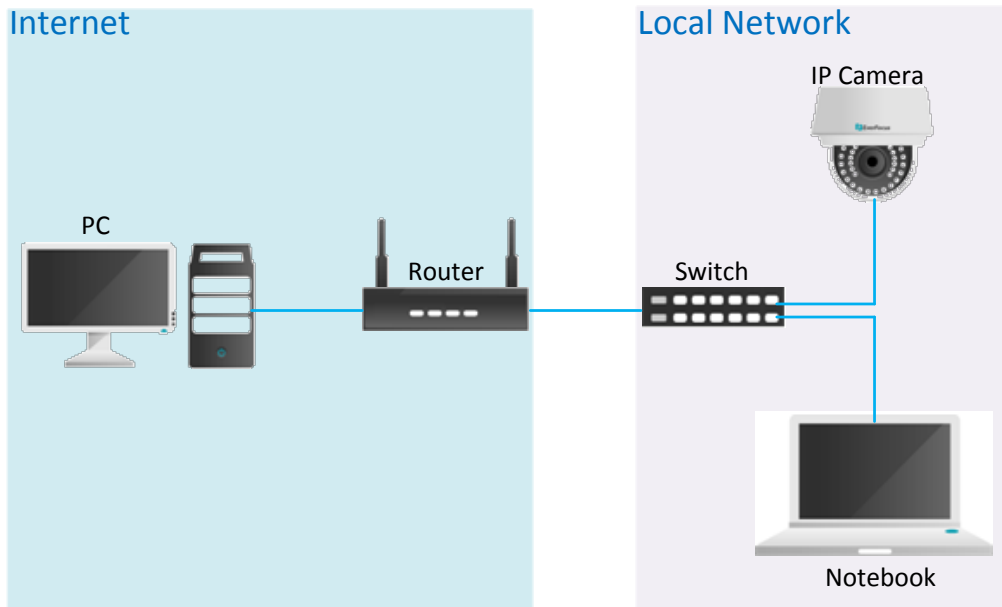

1. Go to System > System Settings > Network > IP Settings.

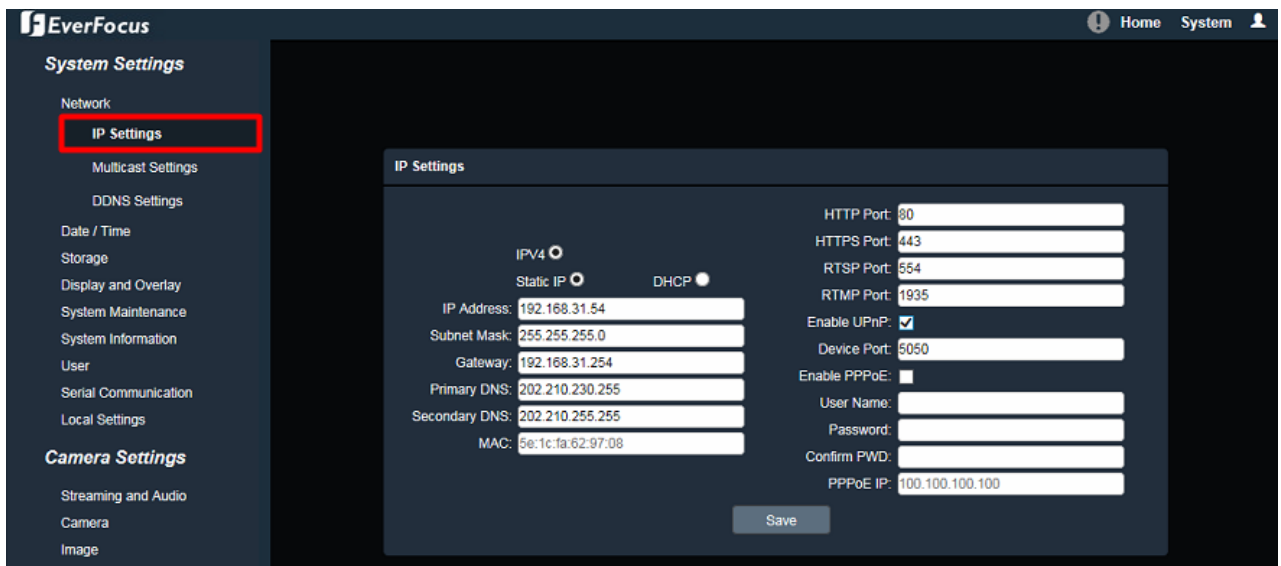

- a. Set up a static IP for the IP camera. Type in the subnet mask, gateway and the DNS if provided by the Internet Service Provider.
- b. Enter the port numbers and check the **Enable UPnP** box to enable the port forwarding function. Click the **Save** button.

The default ports of all EverFocus' IP cameras are as below. You can change the port numbers if necessary. Be sure the port numbers setup on the router match the ones setup here.

HTTP: 80

HTTPS: 443

RTSP: 554

- Set up the port forwarding settings on the router. Here we use D-Link's router for example.

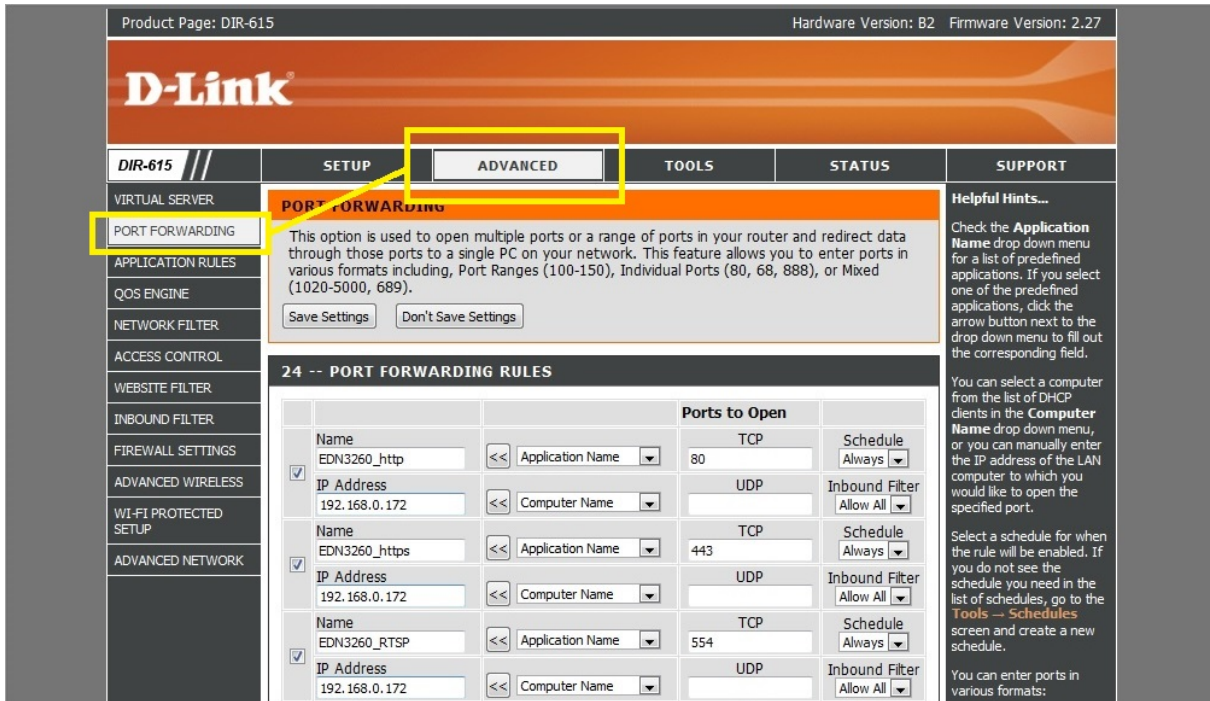

Please be noted that each router may look different in some ways, however, the concept of the port forwarding setting is the same. For more details, please consult the manual of your router.

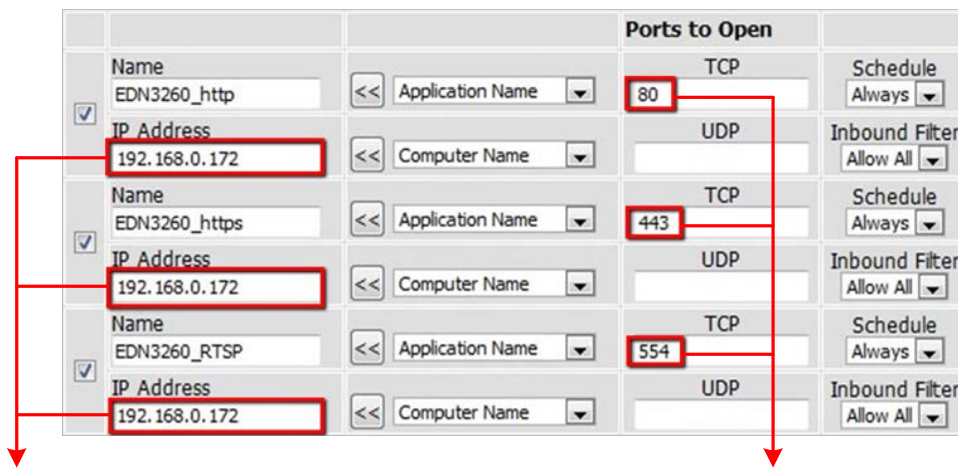

Enter the IP address of the IP camera

Enter the HTTP/HTTPS/RTSP port numbers of the IP camera

- Open a browser and type in the IP address of the router, now you are able to access the IP camera from the Internet.

**D. Setting up DDNS Function**

If you set up your IP Camera with DHCP network, the IP address of your IP Camera may change at different times for different reasons, particularly after a power failure. The changing IP address of the IP Camera may cause you difficulties accessing the IP Camera. To solve this problem, you can set up the DDNS function to your IP Camera, and access your IP Camera with a fixed host name whenever the IP address of your IP Camera changes.

DDNS (Dynamic Domain Name System) is a service used to map a domain name to the dynamic IP address of a network device. It assigns a domain name (URL) to the IP Camera, so that the user does not need to go through the trouble of checking if the IP address assigned by DHCP Server has changed. Once the IP is changed, the IP Camera will automatically update the information to the DDNS to ensure it is always available for remote access.

To set up DDNS for your IP Camera, you have to 1) enable the DMZ or Port Forwarding function of your router 2) configure the network setting of your IP Camera 3) configure the DDNS setting of your IP Camera. Please follow the steps below.

**To enable the DDNS function:**

1. In order to access the IP camera from outside of the local network, enable either the **Port Forwarding** or **DMZ** function of your router. Please refer to the manual of your router for more details.



**Note:** If you enable the Port Forwarding of your router, the **Enable UPnP Port Forwarding** function must be enabled on the IP camera (see **Port Settings** field in the *Step 2* image).



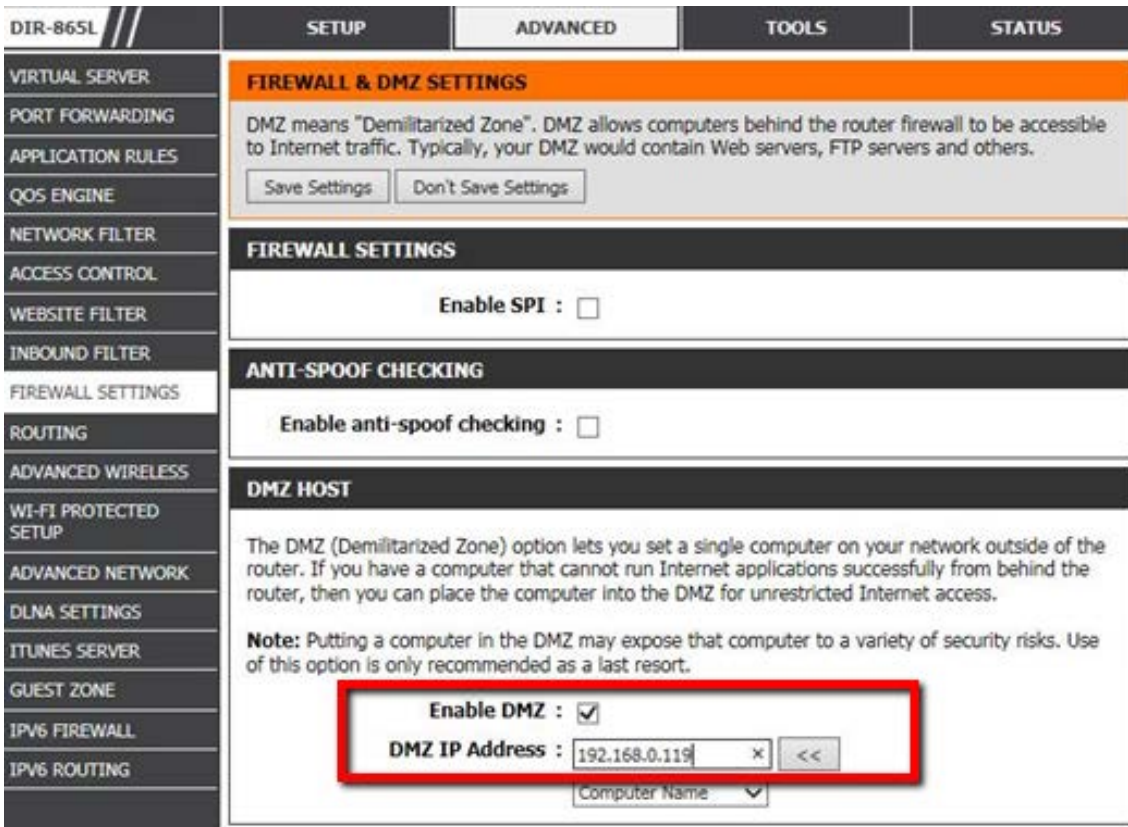

- On the Network Setting page (Setting > System Settings > Network > IP Settings), configure the IP Settings, keep the default Port Settings and then click the **Save** button.

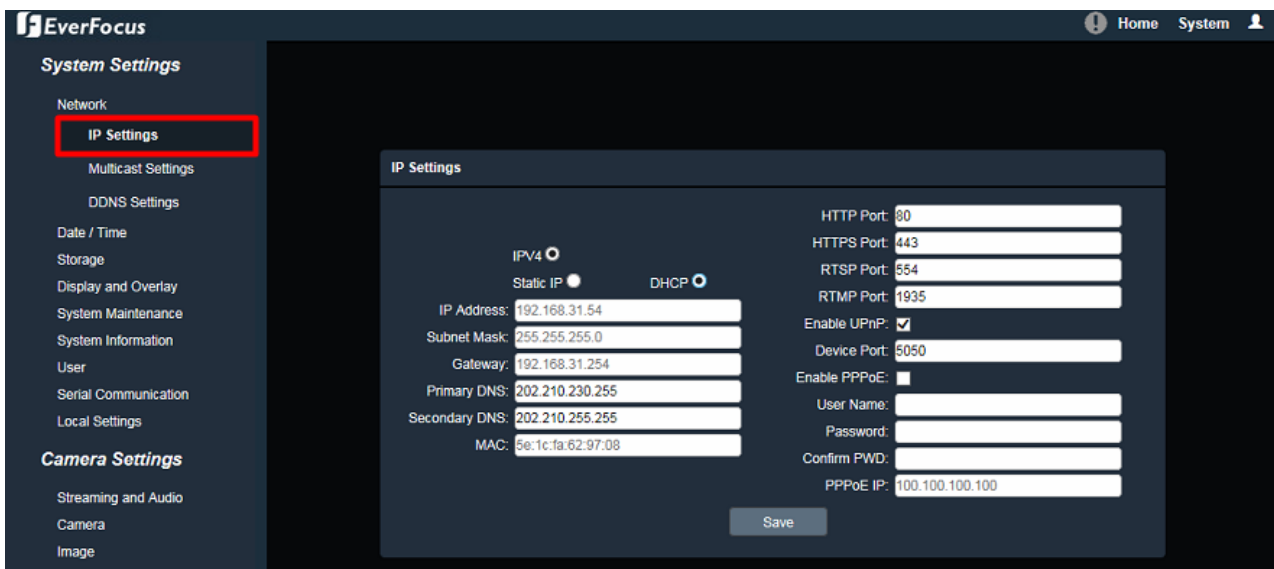

- If **Static IP** is selected: Enter the IP address, subnet mask, default gateway and the DNS Server. Please consult with your ISP service provider for the information of subnet mask, default gateway and the DNS Server.
- If **DHCP** is selected: The IP address, subnet mask, default gateway and the DNS Server will be assigned automatically by DHCP server.
- If **Enable PPPoE** is selected: Enter the User Name (e.g. xxxx@hinet.net) and Password provided by your ISP service provider.

3. In the DDNS Settings field (Setting > System Settings > Network > DDNS Settings), register a free host name from EverFocus DDNS and then click the **Save** button.

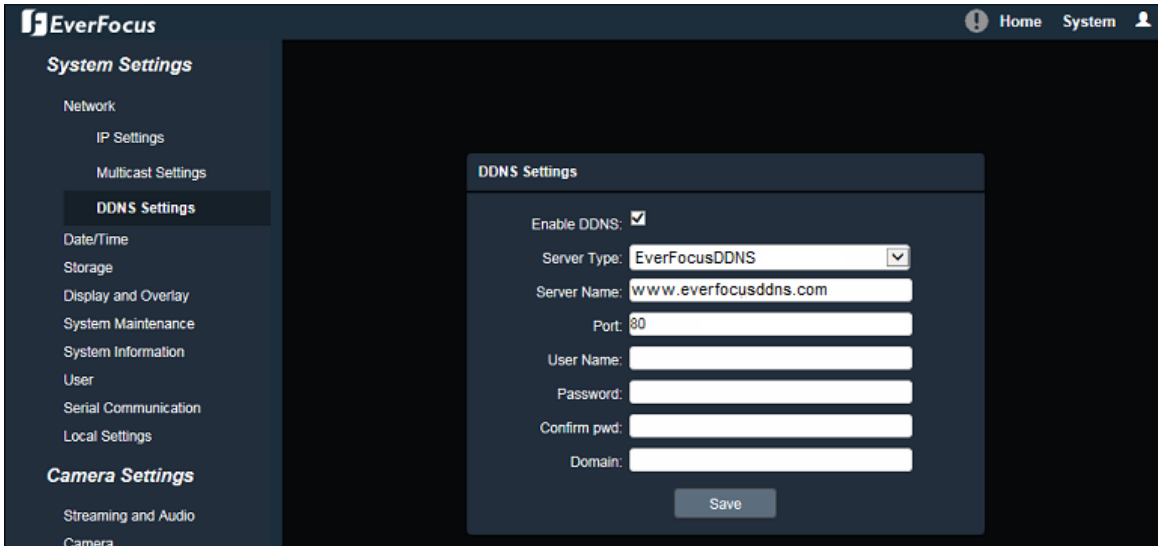

- a. Check **Enable DDNS** to enable the DDNS function.
- b. Select **www.everfocusddns.com** and enter a desired host name in the **Domain** field.

**Note:** The host name should not include a space, or a dot (period) or any special characters particularly `_~!@#$%^&*()+<>"';:.,`

- c. Click **Save**.
4. The DDNS setup is now complete. Open a browser and enter the domain name (`http://[host name].everfocusddns.com`) in the address field. The Web interface of the device should be displayed. For example, if you've obtained the host name "HQtest" from EverFocus DDNS server, enter <http://HQtest.everfocusddns.com> in the address field of the browser.

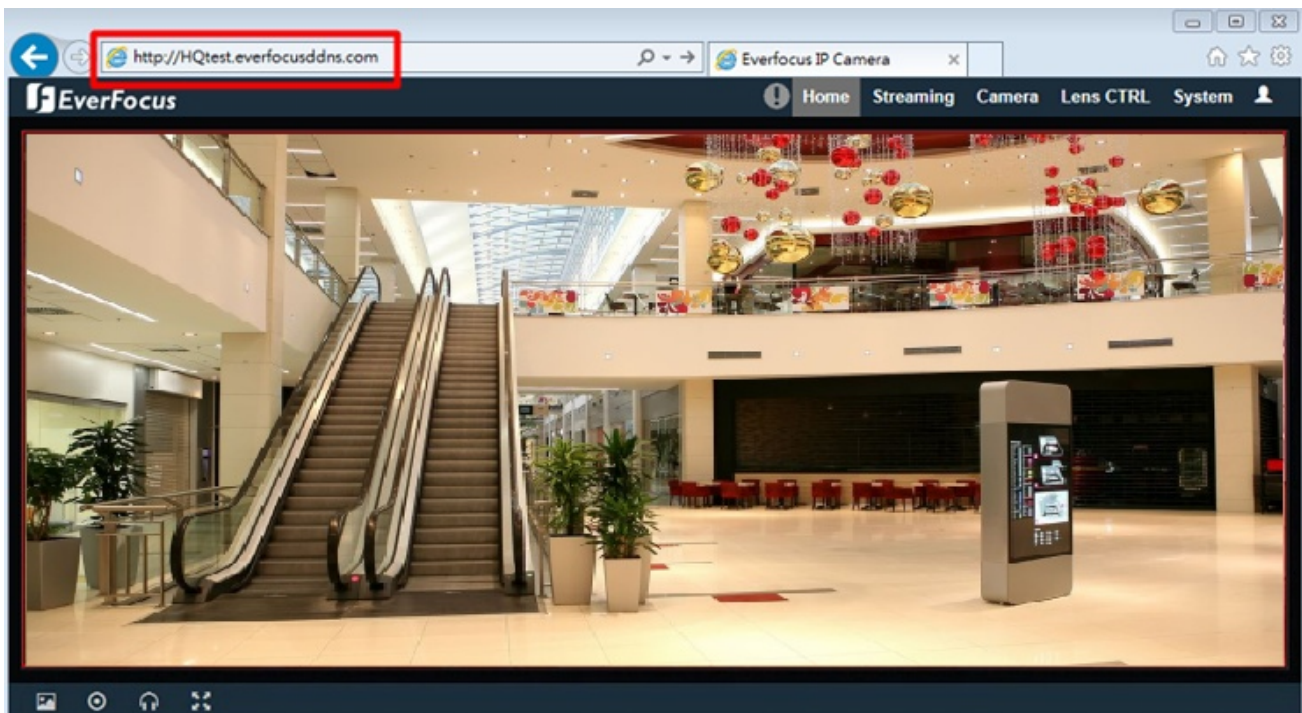

# EverFocus Electronics Corp.

## EverFocus Taiwan:

12F-1, No.79, Sec. 1, Shin-Tai Wu Road,  
Hsi-Chih, New Taipei City, Taiwan  
TEL: +886 2 2698 2334  
FAX: +886 2 2698 3943  
[www.everfocus.com.tw](http://www.everfocus.com.tw)  
[marketing@everfocus.com.tw](mailto:marketing@everfocus.com.tw)

## EverFocus China - Beijing:

Room 609, Technology Trade Building,  
Shangdi Information Industry Base,  
Haidian District, Beijing 100085, China  
TEL: +86 10 6297 3336~39  
FAX: +86 10 6297 1423  
[www.everfocus.com.cn](http://www.everfocus.com.cn)  
[marketing@everfocus.com.cn](mailto:marketing@everfocus.com.cn)

## EverFocus USA - California:

1801 Highland Avenue, Unit A, Duarte, CA 91010,  
USA  
TEL: +1 626 844 8888  
FAX: +1 626 844 8838  
[www.everfocus.com](http://www.everfocus.com)  
[sales@everfocus.com](mailto:sales@everfocus.com)

## EverFocus Europe - Germany:

Albert-Einstein-Strasse 1, D-46446  
Emmerich, Germany  
TEL: +49 2822 93940  
FAX: +49 2822 939495  
[www.everfocus.de](http://www.everfocus.de)  
[sales@everfocus.de](mailto:sales@everfocus.de)

## EverFocus China - Shenzhen:

3F, Building 7, Longcheng Industrial  
Park, No.440, Longguan Road, Dalang Street,  
Longhua, Shenzhen, Guangdong, China  
TEL: +86 755 2765 1313  
FAX: +86 755 2765 0337  
[www.everfocus.com.cn](http://www.everfocus.com.cn)  
[marketing@everfocus.com.cn](mailto:marketing@everfocus.com.cn)

## EverFocus Japan:

3F, Kuramochi, Building II  
2-2-3 Koto-Bashi, Sumida-Ku,  
Tokyo, 130-0022, Japan  
TEL: +81 3 5625 8188  
FAX: +81 3 5625 8189  
[www.everfocus.co.jp](http://www.everfocus.co.jp)  
[info@everfocus.co.jp](mailto:info@everfocus.co.jp)

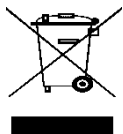

Your EverFocus product is designed and manufactured with high quality materials and components which can be recycled and reused. This symbol means that electrical and electronic equipment, at their end-of-life, should be disposed of separately from your household waste. Please, dispose of this equipment at your local community waste collection/recycling centre. In the European Union there are separate collection systems for used electrical and electronic product. Please, help us to conserve the environment we live in!

Ihr EverFocus Produkt wurde entwickelt und hergestellt mit qualitativ hochwertigen Materialien und Komponenten, die recycelt und wieder verwendet werden können. Dieses Symbol bedeutet, dass elektrische und elektronische Geräte am Ende ihrer Nutzungsdauer vom Hausmüll getrennt entsorgt werden sollen. Bitte entsorgen Sie dieses Gerät bei Ihrer örtlichen kommunalen Sammelstelle oder im Recycling Centre. Helfen Sie uns bitte, die Umwelt zu erhalten, in der wir leben!

