



Cisco 5520 Wireless Controller Installation Guide

First Published: 2015-06-03

Last Modified: 2016-11-11

Americas Headquarters

Cisco Systems, Inc.
170 West Tasman Drive
San Jose, CA 95134-1706
USA
<http://www.cisco.com>
Tel: 408 526-4000
800 553-NETS (6387)
Fax: 408 527-0883

THE SPECIFICATIONS AND INFORMATION REGARDING THE PRODUCTS IN THIS MANUAL ARE SUBJECT TO CHANGE WITHOUT NOTICE. ALL STATEMENTS, INFORMATION, AND RECOMMENDATIONS IN THIS MANUAL ARE BELIEVED TO BE ACCURATE BUT ARE PRESENTED WITHOUT WARRANTY OF ANY KIND, EXPRESS OR IMPLIED. USERS MUST TAKE FULL RESPONSIBILITY FOR THEIR APPLICATION OF ANY PRODUCTS.

THE SOFTWARE LICENSE AND LIMITED WARRANTY FOR THE ACCOMPANYING PRODUCT ARE SET FORTH IN THE INFORMATION PACKET THAT SHIPPED WITH THE PRODUCT AND ARE INCORPORATED HEREIN BY THIS REFERENCE. IF YOU ARE UNABLE TO LOCATE THE SOFTWARE LICENSE OR LIMITED WARRANTY, CONTACT YOUR CISCO REPRESENTATIVE FOR A COPY.

The Cisco implementation of TCP header compression is an adaptation of a program developed by the University of California, Berkeley (UCB) as part of UCB's public domain version of the UNIX operating system. All rights reserved. Copyright © 1981, Regents of the University of California.

NOTWITHSTANDING ANY OTHER WARRANTY HEREIN, ALL DOCUMENT FILES AND SOFTWARE OF THESE SUPPLIERS ARE PROVIDED "AS IS" WITH ALL FAULTS. CISCO AND THE ABOVE-NAMED SUPPLIERS DISCLAIM ALL WARRANTIES, EXPRESSED OR IMPLIED, INCLUDING, WITHOUT LIMITATION, THOSE OF MERCHANTABILITY, FITNESS FOR A PARTICULAR PURPOSE AND NON-INFRINGEMENT OR ARISING FROM A COURSE OF DEALING, USAGE, OR TRADE PRACTICE.

IN NO EVENT SHALL CISCO OR ITS SUPPLIERS BE LIABLE FOR ANY INDIRECT, SPECIAL, CONSEQUENTIAL, OR INCIDENTAL DAMAGES, INCLUDING, WITHOUT LIMITATION, LOST PROFITS OR LOSS OR DAMAGE TO DATA ARISING OUT OF THE USE OR INABILITY TO USE THIS MANUAL, EVEN IF CISCO OR ITS SUPPLIERS HAVE BEEN ADVISED OF THE POSSIBILITY OF SUCH DAMAGES.

Any Internet Protocol (IP) addresses and phone numbers used in this document are not intended to be actual addresses and phone numbers. Any examples, command display output, network topology diagrams, and other figures included in the document are shown for illustrative purposes only. Any use of actual IP addresses or phone numbers in illustrative content is unintentional and coincidental.

Cisco and the Cisco logo are trademarks or registered trademarks of Cisco and/or its affiliates in the U.S. and other countries. To view a list of Cisco trademarks, go to this URL: <http://www.cisco.com/go/trademarks>. Third-party trademarks mentioned are the property of their respective owners. The use of the word partner does not imply a partnership relationship between Cisco and any other company. (1110R)

© 2016 Cisco Systems, Inc. All rights reserved.



CONTENTS

Preface

Preface v

About this Guide v

Conventions v

Related Documentation vi

Obtaining Documentation and Submitting a Service Request vi

CHAPTER 1

Overview of Cisco 5520 Wireless Controller 1

Summary of Cisco 5520 Wireless Controller Features 1

Platform Components 2

Cisco 5520 Wireless Controller Front Panel View 2

Front Panel LEDs: Definitions of States 3

Front Panel KVM Breakout Connector 4

Cisco 5520 Wireless Controller Rear Panel View 5

Rear Panel LEDs: Definitions of States 6

Setting Up the CIMC Interface 7

Switching Between 10 G and 1 G 8

SFP Support 8

Customer Replaceable Units 9

References 10

CHAPTER 2

Installing the Cisco 5520 Wireless Controller 11

Unpacking and Inspecting the Controller 11

Preparing for Controller Installation 12

Installation Guidelines 12

Rack Requirements 13

Equipment Requirements 13

Slide Rail Adjustment Range 13

- Installing the Controller in a Rack 13
 - Installing the Slide Rails 13
 - Installing the Cable Management Arm (Optional) 16
 - Reversing the Cable Management Arm (Optional) 18
- Initial Controller Setup 18
- System BIOS and Cisco Integrated Management Controller Firmware 19
 - Updating the BIOS and Cisco Integrated Management Controller Firmware 19
 - Accessing System BIOS 19

APPENDIX A

Controller Specifications 21

- Physical Specifications 21
- Environmental Specifications 21
- Power Specifications 22
 - 770 W AC Power Supply 22

APPENDIX B

Power Cord Specifications 25

- Supported Power Cords and Plugs 25
- AC Power Cord Illustrations 28



Preface

This preface describes this guide and provides information about the conventions used in this guide, and related documentation. It includes the following sections:

- [About this Guide, page v](#)
- [Conventions, page v](#)
- [Related Documentation, page vi](#)
- [Obtaining Documentation and Submitting a Service Request, page vi](#)

About this Guide

This guide is designed to help experienced network administrators install and minimally configure Cisco 5520 Wireless Controller.

Conventions

This document uses the following conventions for notes, cautions, and safety warnings. Notes and cautions contain important information that you should know.



Note

Means *reader take note*. Notes contain helpful suggestions or references to material not covered in the manual.



Caution

Means *reader be careful*. Cautions contain information about something you might do that could result in equipment damage or loss of data.



Warning

Safety warnings appear throughout this guide in procedures that, if performed incorrectly, can cause physical injuries. A warning symbol precedes each warning statement.

Related Documentation

- For information about Cisco Wireless Controller software, see:
<http://www.cisco.com/c/en/us/support/wireless/wireless-lan-controller-software/tsd-products-support-series-home.html>
- For information about the Cisco 5520 Wireless Controller, see:
<http://www.cisco.com/c/en/us/support/wireless/5500-series-wireless-controllers/tsd-products-support-series-home.html>
- *Cisco 5520 Wireless Controller Deployment Guide*
http://www.cisco.com/c/en/us/td/docs/wireless/controller/technotes/8-1/5520-WLC-DG/b_Cisco-5520-WLC-deployment-guide.html
- *Regulatory Compliance and Safety Information*
<http://www.cisco.com/c/dam/en/us/td/docs/wireless/controller/5500/5520/regulatory/RCSI-0294-book.pdf>

Obtaining Documentation and Submitting a Service Request

For information on obtaining documentation, using the Cisco Bug Search Tool (BST), submitting a service request, and gathering additional information, see [What's New in Cisco Product Documentation](#).

To receive new and revised Cisco technical content directly to your desktop, you can subscribe to the [What's New in Cisco Product Documentation RSS feed](#). RSS feeds are a free service.



CHAPTER 1

Overview of Cisco 5520 Wireless Controller

The Cisco 5520 Wireless Controller provides centralized control, management, and troubleshooting for high-scale deployments in service provider and large campus deployments. It offers flexibility to support multiple deployment modes in the same controller: for example, centralized mode for campus, Cisco FlexConnect mode for lean branches managed over the WAN, and mesh (bridge) mode for deployments where full Ethernet cabling is unavailable. As a component of the Cisco Unified Wireless Network, this controller provides real-time communications between Cisco Aironet access points, the Cisco Prime Infrastructure, and the Cisco Mobility Services Engine, and is interoperable with other Cisco controllers.

For more information about features and benefits, see the [Cisco 5520 Wireless Controller Datasheet](#).

Figure 1: Cisco 5520 Wireless Controller



- [Summary of Cisco 5520 Wireless Controller Features, page 1](#)
- [Platform Components, page 2](#)

Summary of Cisco 5520 Wireless Controller Features

Table 1: Cisco 5520 Wireless Controller Features

Feature	Description
Chassis Height	One rack-unit (1RU)
Throughput	20 Gbps
AP Support	1500

Feature	Description
Client Support	20000
Data Ports	2x SFP+
Storage Temperature	-40 to 149°F (-40 to 65°C)
Operating Temperature	41 to 104°F (5 to 40°C)
Operating Humidity	10–90% (noncondensing)
Power Options	770W AC

Platform Components

Cisco 5520 Wireless Controller Front Panel View

Cisco 5520 Wireless Controller has several buttons, LED indicators, and a KVM connector on the front panel.

Figure 2: Cisco 5520 Wireless Controller Front Panel View

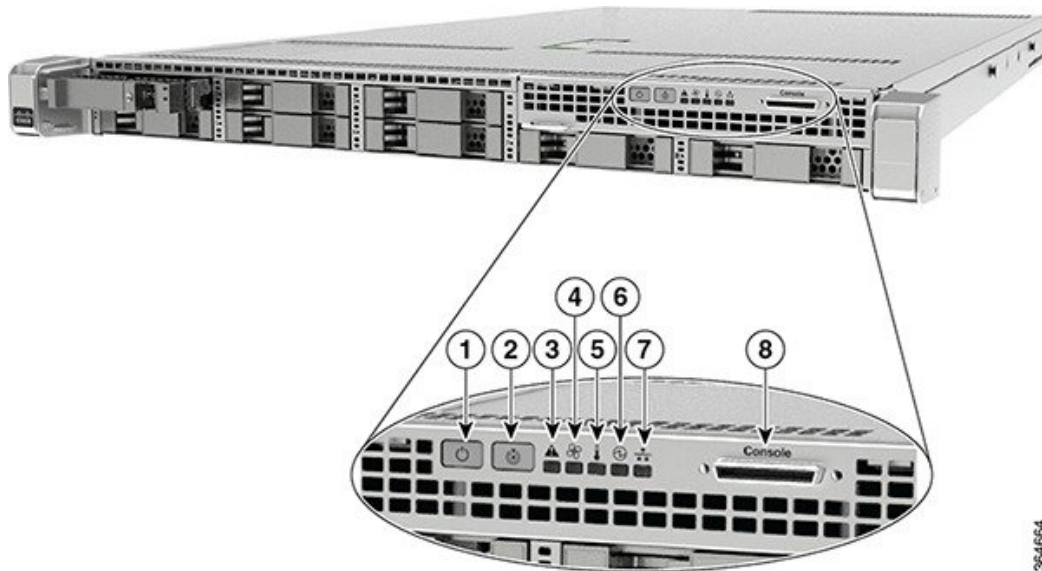

1	Power button/power status LED	5	Temperature status LED
2	Locator (Unit identification) button LED	6	Power supply status LED

3	System status LED	7	Network link activity LED (this indicates the network activity only on Service port, RP port, and CIMC port)
4	Fan status LED	8	KVM connector (used with KVM cable that provides two USB 2.0, one VGA, and one serial connector)



Note

The power supply, fan, and temperature status are periodically polled from the Cisco WLC software in the intervals of 600 seconds (10 minutes). Therefore, any change in the status of power supply, fan, or temperature can take up to 600 seconds to be reflected. However, the **show imm chassis** command can show the current status.

Front Panel LEDs: Definitions of States

Table 2: Cisco 5520 Wireless Controller Front Panel LEDs: Definitions of States

LED Name	Function	State
Power Button	Indicates the system power status	Off—System power is off Amber On—Soft off Green On—System power is on
Locator (Unit Identification) Button	A Unit Identify push button with integrated LED is available on the front panel and rear panel. Each press on the button toggles between active and non-active states	Off—The unit identification function is not in use Blue—The unit identification function is activated
System Status	Indicates the overall system health	Green On—System is in normal operating condition Amber On—System is in a degraded operational state Amber Blinking—Critical Fault State
Fan Status	Indicates the fan health	Green On—Fans are operating and no error condition has been detected Amber On—Fans are in a degraded operational state. One of N fans has a fault Amber Blinking—Critical fault state. Two or more fans have a fault

LED Name	Function	State
Temperature Status	Indicates whether or not the system is operating within acceptable temperature limits.	Green On—System is operating at normal temperature Amber On—One or more temperature sensors reaches UCR threshold Amber Blinking—One or more temperature sensors reaches UNR threshold
Power Supply Status	Indicates the functioning of the power supply	Green On—AC power supplies are operating and no error condition has been detected Amber On—One or more power supplies are in a degraded operational state Amber Blinking—One or more power supplies are in a critical fault state
Network Link Activity	Indicates the network activity only on Service port, RP port, and CIMC port	Green On—Link on any of the ports, but no activity Green Blinking—Activity on any of the ports

Front Panel KVM Breakout Connector

A single female connector provides access to video, two USB ports for keyboard and mouse, and an RS-232C console serial port. An external breakout connector to industry standard interfaces is required. The following figure shows a sample cable.

Figure 3: Front Panel KVM Breakout Connector

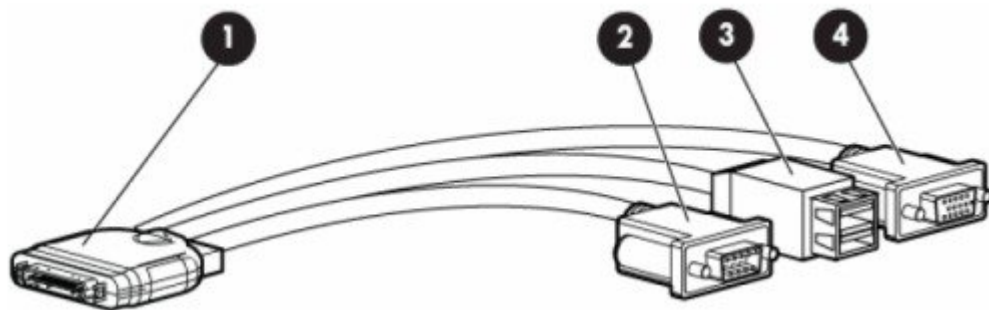

The interfaces for the cable are as follows:

- Front panel KVM/Console connector
- DB9 serial port connector
- Dual Type-A USB 2.0 connectors
- DB15 Video connector (does not show anything once the Cisco WLC software starts except the initial BIOS parameters. All the prints from this point onwards are available on the serial console)

Cisco 5520 Wireless Controller Rear Panel View

Figure 4: Cisco 5520 Wireless Controller Rear Panel View

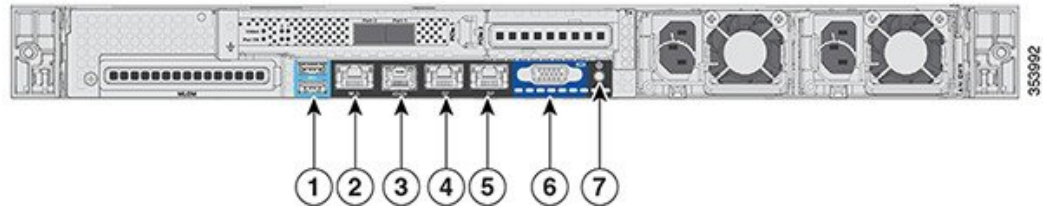

1	Two Type A 3.0 USB ports	5	Redundancy Port (RP)
2	CIMC port 10/100/1000 Base-T	6	VGA Connector—Rear panel has a standard VGA port using a female D-Sub-15 Connector (does not show anything once the Cisco WLC software starts except the initial BIOS parameters. All the prints from this point onwards are available on the serial console)
3	SerialCOM Connector—Standard RS-232 Serial COM port using RJ-45 connector	7	ID Switch and LED
4	Ethernet Service Port (SP)—Management 10/100/1000 Base-T		

Figure 5: Cisco 5520 Wireless Controller Rear Panel SFP Ports and LEDs

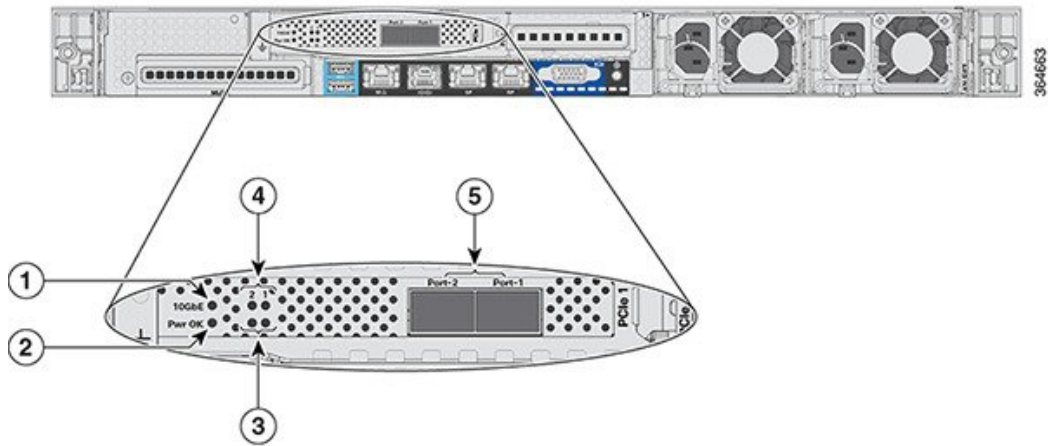

1	10 G	4	Port-n Link Activity
2	Pwr OK	5	Two 1/10 G SFP/SFP+ Ports
3	Port-n Link Status		

Rear Panel LEDs: Definitions of States

Table 3: Cisco 5520 Wireless Controller Rear Panel LEDs: Definitions of States

LED Name	Function	State
Pwr OK	—	Amber On—Power is good
10 G	—	Amber On—10 G mode Amber Off—1 G mode
Port-n Link Status	—	Green On—Link is up in 10 GbE mode Amber On—Link is up in 1 GbE mode Off—Link status is down
Port-n Link Activity	—	Green blinking—Link activity

LED Name	Function	State
Service Port and Redundancy Port LED (present on the port)	Interface Port Speed (the left LED on the port)	Off—Link Speed = 10 Mbps Amber On—Link Speed = 100 Mbps Green On—Link Speed = 1 Gbps
	Interface Port Status (the right LED on the port)	Off—No link Green On—Link Blinking—Traffic present

Setting Up the CIMC Interface

Perform these tasks to set up the CIMC interface:

- Step 1** Connect the CIMC cable to the CIMC management port.
The CIMC management port is shown in [Figure 1-3 on page 1-4](#).
- Step 2** Press the Power On button in front of the unit, and wait until you see the login prompt.
- Step 3** Enter the username as admin and password as either password or Cisco1234 respectively to get to the Cisco WLC CLI prompt, and follow the CIMC setup step.

Example:

```
(Cisco Controller)
Enter User Name (or 'Recover-Config' this one-time only to reset configuration to factory defaults)

User: admin
Password:*****
```

Note You can also set up CIMC via console during bootup from power reset. You can use the F8 key to configure the CIMC.

- Step 4** Enable DHCP to set the IP by entering the **imm dhcp enable** command.
- Step 5** If DHCP is not available, use the **imm address ip-addr net-mask gateway-ip-addr** command.
- Step 6** View the IP and details by entering the **imm summary** command.

Example:

```
(Cisco Controller) >imm ?
address      IMM Static IP Configuration
dhcp        Enable | Disable | Fallback DHCP
restart      Saves settings and Restarts IMM Module
summary      Displays IMM Parameters
username     Configures Login Username for IMM
(Cisco Controller) >show imm chassis ?
bios         Fetch Chassis BIOS information
current     Fetch Chassis Current information
fan         Fetch Chassis Fan information
mac         Fetch Chassis MAC information
memory      Fetch Chassis Memory information
power-s     Fetch Chassis Power Supply information
```

```
sol-info          Fetch Chassis Serial Over LAN information
temperature      Fetch Chassis Temperature information
```

Note CIMC web interface is for advanced debugging for TAC and escalation use only. Changing of settings in the CIMC by customers can cause adverse impact on controller software and functionality.

Switching Between 10 G and 1 G

- The SFP installed in port 1 determines the modes for port 2 at power-up; the mode cannot be changed after power-up. The default modes for both the ports is 10G when no SFP is installed in port 1.
- Conversely, if an SFP module is installed and the user wants to switch to 2x 10G mode, then an SFP+ module must be installed in port 1 and the WLC rebooted.
- Thus, Online Insertion and Removal (OIR) of SFP and SFP+ between 10G and 1G is not possible.
- OIR of 10G to 10G and 1G and 1G is possible.



Note

We do not recommend a mix of 1G and 10G SFPs. In case they are different, port 1 SFP determines the mode of operation and functionality on the other SFPs may not work. The SFP/SFP+ must be MSA-compliant for the units to configure the 1G/10G modes correctly.

Table 4: Functionality of Cisco 5520 WLC when OIR Occurs

Hot Swap of SFP/SFP+	Port1	Port2	Remarks
1G to 1G	No	Yes	Cisco 5520 WLC requires reboot for Port1 OIR in 1G
1G to 10G	No	No	Cisco 5520 WLC requires reboot between 1G and 10G
10G to 1G	No	No	Cisco 5520 WLC requires reboot between 10G and 1G
10G to 10G	Yes	Yes	No reboot required

SFP Support

Network ports for Cisco 5520 Wireless Controllers support the following Cisco SFP/SFP+ modules:

- GLC-TE
- GLC-T

- SFP-10G-SR
- SFP-10G-LR
- SFP-10G-LRM
- SFP-H10GB-CU1M
- SFP-H10GB-CU2M
- SFP-H10GB-CU2-5M
- SFP-H10GB-CU3M
- SFP-H10GB-CU5M
- SFP-H10GB-ACU7M
- SFP-H10GB-ACU10M
- SFP-10G-AOC7M
- SFP-H10GB-CU1-5M
- SFP-10G-AOC3M
- SFP-10G-AOC1M
- SFP-10G-AOC2M
- SFP-10G-AOC5M
- SFP-10G-AOC10M
- GLC-LH *
- GLC-EX-SMD *
- GLC-SX-MMD *
- SFP-10G-SR-S
- SFP-10G-LR-S

**Note**

* Needs GLC-T on Port 1.

Customer Replaceable Units

Cisco 5520 Wireless Controller has a minimal amount of separate orderable items, including all of the following:

- Power supply (AIR-PSU1-770W=)
- SSD Hard Disk Drive (HDD) (AIR-SD240G0KS2-EV=)
- Option to add a redundant power supply on the Cisco 5520 WLC (AIR-PSU1-770W=)

References

- For instructions about how to replace the power supplies, see the "Replacing Power Supplies" section at: http://www.cisco.com/c/en/us/td/docs/unified_computing/ucs/c/hw/C220M4/install/C220M4/replace.html
- For instructions about how to replace the SSD Hard Disk Drive (HDD), see the "Replacing Hard Drives or Solid State Drives" section at: http://www.cisco.com/c/en/us/td/docs/unified_computing/ucs/c/hw/C220M4/install/C220M4/replace.html



Note

Only the HDD01 drive on the 8-drive version is applicable to the Cisco 5520 Wireless Controller.



CHAPTER 2

Installing the Cisco 5520 Wireless Controller

This chapter describes how to install the Cisco 5520 Wireless Controller.



Warning

IMPORTANT SAFETY INSTRUCTIONS

This warning symbol means danger. You are in a situation that could cause bodily injury. Before you work on any equipment, be aware of the hazards involved with electrical circuitry and be familiar with standard practices for preventing accidents. Use the statement number provided at the end of each warning to locate its translation in the translated safety warnings that accompanied this device. **Statement 1071**

SAVE THESE INSTRUCTIONS

- [Unpacking and Inspecting the Controller, page 11](#)
- [Preparing for Controller Installation, page 12](#)
- [Installing the Controller in a Rack, page 13](#)
- [Initial Controller Setup, page 18](#)
- [System BIOS and Cisco Integrated Management Controller Firmware, page 19](#)

Unpacking and Inspecting the Controller



Caution

When handling internal controller components, wear an ESD strap and handle modules by the carrier edges only.



Tip

Retain the shipping container in case the controller requires shipping in the future.

**Note**

The chassis is thoroughly inspected before shipment. If any damage occurred during transportation or any items are missing, contact your customer service representative immediately.

-
- Step 1** Remove the controller from its container and save all the packaging material.
- Step 2** Compare the shipment to the equipment list provided by your Cisco customer service representative. Verify that you have all the items.
- Step 3** Check for damage and report discrepancies or damage, if any, to your Cisco customer service representative. Before speaking to the representative, have the following information ready:
- Invoice number of shipper (see the packing slip)
 - Model and serial number of the damaged unit
 - Description of damage
 - Effect of damage on the installation
-

Preparing for Controller Installation

Installation Guidelines

**Warning**

To prevent the system from overheating, do not operate it in an area that exceeds the maximum recommended ambient temperature of: 40° C (104° F). **Statement 1047**

**Warning**

The plug-socket combination must be accessible at all times, because it serves as the main disconnecting device. **Statement 1019**

**Warning**

This product relies on the building's installation for short-circuit (overcurrent) protection. Ensure that the protective device is rated not greater than: 250 V, 15 A. **Statement 1005**

**Warning**

Installation of the equipment must comply with local and national electrical codes. **Statement 1074**

**Caution**

To ensure proper airflow it is necessary to rack the controllers using rail kits. Physically placing the units on top of one another or “stacking” without the use of the rail kits blocks the air vents on top of the controllers, which could result in overheating, higher fan speeds, and higher power consumption. We recommend that you mount your controllers on rail kits when you are installing them into the rack because these rails provide the minimal spacing required between the controllers. No additional spacing between the controllers is required when you mount the units using rail kits.

The rail mounting kit (Part Number: UCSC-RAILB-M4=) is provided along with the Cisco 5520 WLC and you do not have to order it separately.

**Caution**

Avoid UPS models that use ferroresonant technology. These UPS models can become unstable with systems such as the Cisco UCS, which can have substantial current draw fluctuations from fluctuating data traffic patterns.

Rack Requirements

This section provides the requirements for the standard open racks.

The rack must be of the following type:

- A standard 19-in. (48.3-cm) wide, four-post EIA rack, with mounting posts that conform to English universal hole spacing, per section 1 of ANSI/EIA-310-D-1992.
- The rack post holes can be square 0.38-inch (9.6 mm), round 0.28-inch (7.1 mm), #12-24 UNC, or #10-32 UNC when you use the supplied slide rails.
- The minimum vertical rack space per controller must be one RU, equal to 1.75 in. (44.45 mm).

Equipment Requirements

The slide rails sold by Cisco Systems for this controller do not require tools for installation.

Slide Rail Adjustment Range

The slide rails for this controller have an adjustment range of 24 to 36 inches (610 to 914 mm).

Installing the Controller in a Rack

Installing the Slide Rails

This section describes how to install the controller in a rack using the rack kits that are sold by Cisco Systems.

**Warning**

To prevent bodily injury when mounting or servicing this unit in a rack, you must take special precautions to ensure that the system remains stable. The following guidelines are provided to ensure your safety: This unit should be mounted at the bottom of the rack if it is the only unit in the rack. When mounting this unit in a partially filled rack, load the rack from the bottom to the top with the heaviest component at the bottom of the rack. If the rack is provided with stabilizing devices, install the stabilizers before mounting or servicing the unit in the rack. **Statement 1006**

Step 1

Attach the inner rails to the sides of the controller:

- a) Align an inner rail with one side of the controller so that the three keyed slots in the rail align with the three pegs on the side of the controller (see *Attaching Inner Rail to Side of Controller*).
- b) Set the keyed slots over the pegs, and then slide the rail toward the front to lock it in place on the pegs. The front slot has a metal clip that locks over the front peg.
- c) Install the second inner rail to the opposite side of the controller.

Figure 6: Attaching Inner Rail to Side of Controller

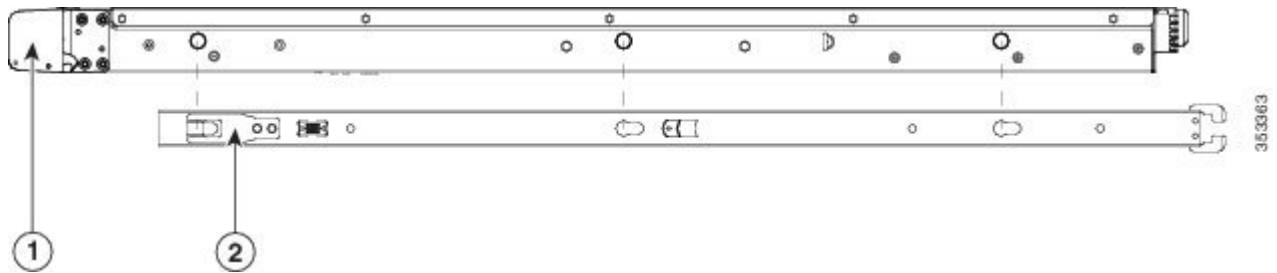

1	Front of controller	2	Locking clip on inner rail
---	---------------------	---	----------------------------

Step 2

Open the front securing plate on both slide-rail assemblies. The front end of the slide-rail assembly has a spring-loaded securing plate that must be open before you can insert the mounting pegs into the rack-post holes (see *Front Securing Mechanism, Inside of Front End*).

On the *outside* of the assembly, push the green arrow button towards the rear to open the securing plate.

Figure 7: Front Securing Mechanism, Inside of Front End

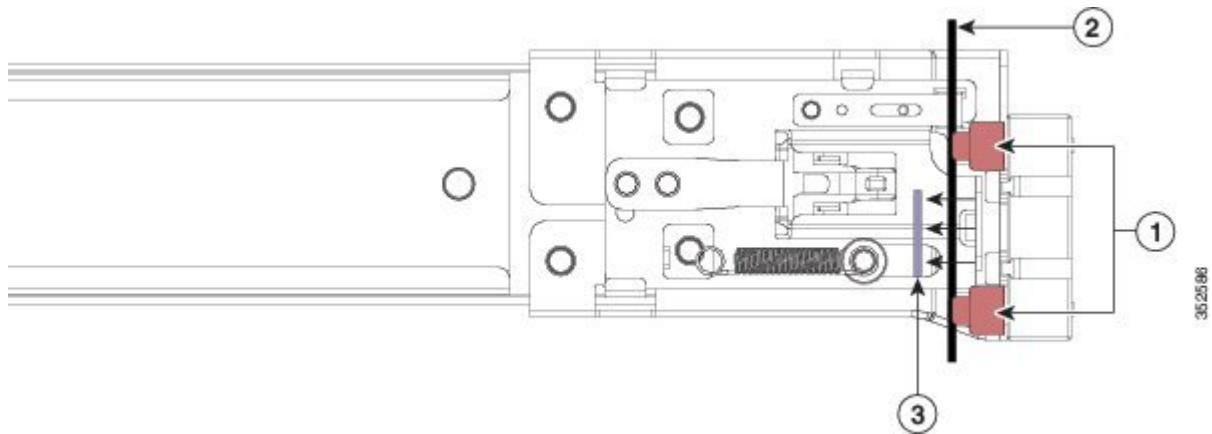

1	Front-mounting pegs	3	Securing plate shown pulled back to Open position
2	Rack post		

Step 3 Install the outer slide rails into the rack:

- a) Align one slide-rail assembly front end with the front rack-post holes that you want to use. The slide rail front-end wraps around the outside of the rack post and the mounting pegs enter the rack-post holes from the outside-front (see *Front Securing Mechanism, Inside of Front End*).

Note The rack post must be between the mounting pegs and the open securing plate.
- b) Push the mounting pegs into the rack-post holes from the outside-front.
- c) Press the securing plate release button, marked PUSH. The spring-loaded securing plate closes to lock the pegs in place.
- d) Adjust the slide-rail length, and then push the rear mounting pegs into the corresponding rear rack-post holes. The slide rail must be level front-to-rear. The rear mounting pegs enter the rear rack-post holes from the inside of the rack post.
- e) Attach the second slide-rail assembly to the opposite side of the rack. Ensure that the two slide-rail assemblies are at the same height with each other and are level front-to-back.
- f) Pull the inner slide rails on each assembly out toward the rack front until they hit the internal stops and lock in place.

Step 4 Insert the controller into the slide rails:

- Caution** This controller can weigh up to 67 pounds (59 kilograms) when fully loaded with components. We recommend that you use a minimum of two people or a mechanical lift when lifting the controller. Attempting this procedure alone could result in personal injury or equipment damage.
- a) Align the rear of the inner rails that are attached to the controller sides with the front ends of the empty slide rails on the rack.
 - b) Push the inner rails into the slide rails on the rack until they stop at the internal stops.

- c) Slide the release clip toward the rear on both inner rails, and then continue pushing the controller into the rack until its front slam latches engage with the rack posts.

Figure 8: Inner Rail Release Clip

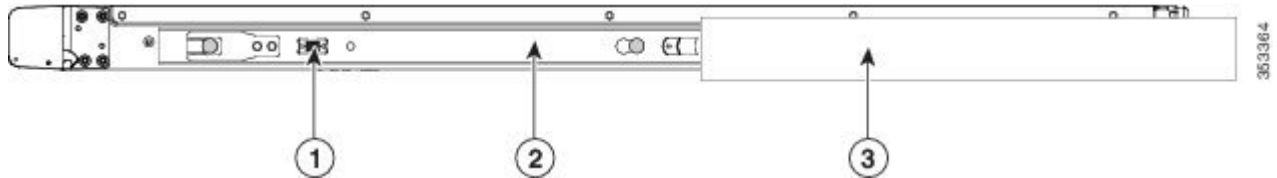

1	Inner rail release clip	3	Outer rail attached to rack post
2	Inner rail attached to controller and inserted into outer rail		

Step 5

(Optional) Secure the controller in the rack more permanently by using the two screws that are provided with the slide rails. Perform this step if you plan to move the rack with controller installed. With the controller fully pushed into the slide rails, open a hinged slam latch lever on the front of the controller and insert the screw through the hole that is under the lever. The screw threads into the static part of the rail on the rack post and prevents the controller from being pulled out. Repeat for the opposite slam latch.

Installing the Cable Management Arm (Optional)

Step 1

With the controller pushed fully into the rack, slide the CMA tab of the CMA arm that is farthest from the controller onto the end of the stationary slide rail that is attached to the rack post (see *Attaching the Cable Management Arm to the Rear of the Slide Rails*). Slide the tab over the end of the rail until it clicks and locks.

Note The CMA is reversible left to right. To reverse the CMA, see *Reversing the Cable Management Arm (Optional)* before installation.

- Step 2** Slide the CMA tab that is closest to the controller over the end of the inner rail that is attached to the controller (see *Attaching the Cable Management Arm to the Rear of the Slide Rails*). Slide the tab over the end of the rail until it clicks and locks.
- Step 3** Pull out the width-adjustment slider that is at the opposite end of the CMA assembly until it matches the width of your rack (see *Attaching the Cable Management Arm to the Rear of the Slide Rails*).
- Step 4** Slide the CMA tab that is at the end of the width-adjustment slider onto the end of the stationary slide rail that is attached to the rack post (see *Attaching the Cable Management Arm to the Rear of the Slide Rails*). Slide the tab over the end of the rail until it clicks and locks.
- Step 5** Open the hinged flap at the top of each plastic cable guide and route your cables through the cable guides, as required.

Figure 9: Attaching the Cable Management Arm to the Rear of the Slide Rails

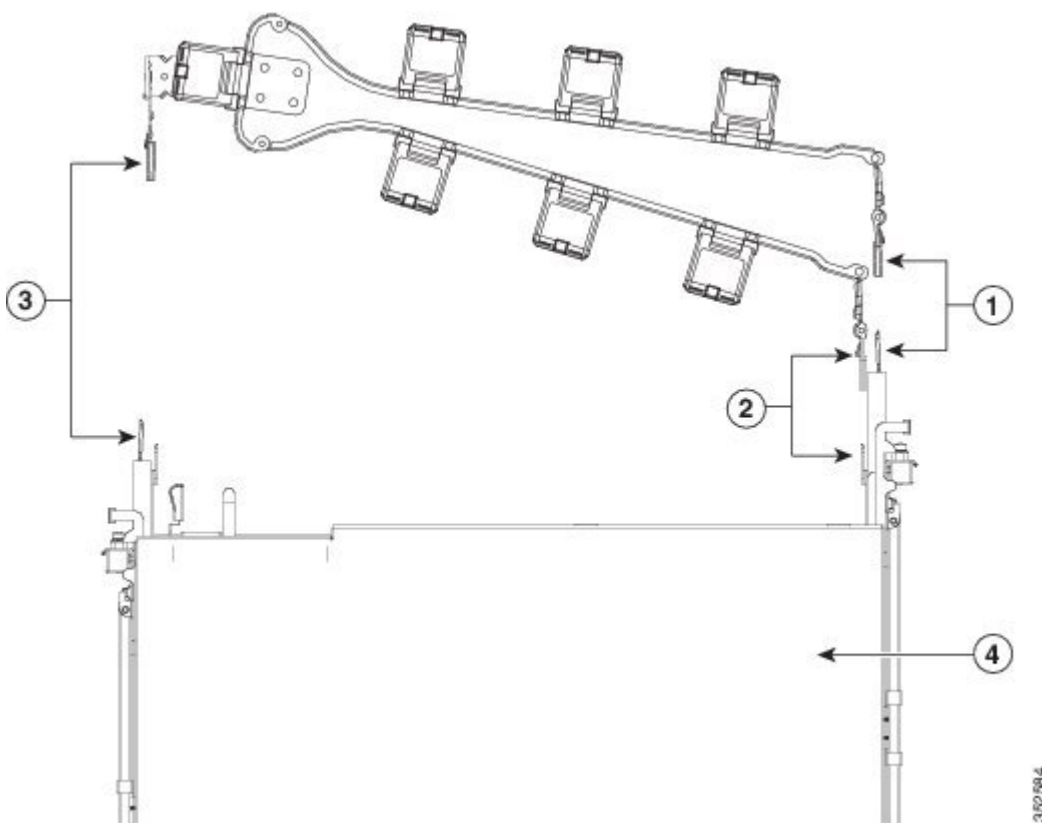

1	CMA tab on arm farthest from controller and end of stationary outer slide rail	3	CMA tab on width-adjustment slider and end of stationary outer slide rail
2	CMA tab on arm closest to the controller and end of inner slide rail attached to controller	4	Rear of controller

Reversing the Cable Management Arm (Optional)

- Step 1** Rotate the entire CMA assembly 180 degrees. The plastic cable guides must remain pointing upward.
- Step 2** Flip the tabs at the end of each CMA arm so that they point toward the rear of the controller.
- Step 3** Pivot the tab that is at the end of the width-adjustment slider. Depress and hold the metal button on the outside of the tab and pivot the tab 180 degrees so that it points toward the rear of the controller.

Figure 10: Reversing the CMA

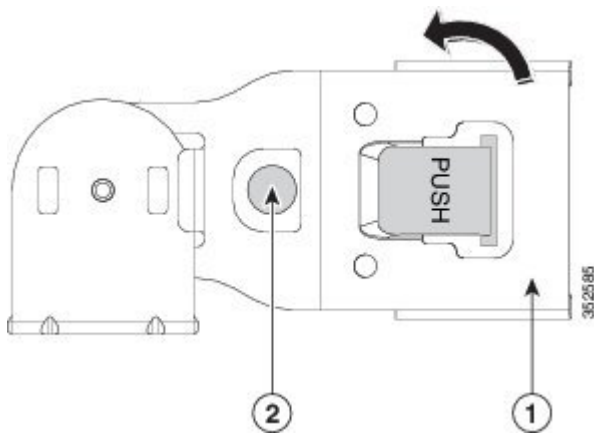

1	CMA tab on end of width-adjustment slider	2	Metal button for rotating
---	---	---	---------------------------

Initial Controller Setup

For instructions on performing initial setup of controller, see the [Cisco 5520 Wireless Controller Deployment Guide](#).

System BIOS and Cisco Integrated Management Controller Firmware

Updating the BIOS and Cisco Integrated Management Controller Firmware

**Caution**

The BIOS and Cisco IMC firmware need not be upgraded when you first bring up the unit.

When you upgrade the BIOS firmware, you must also upgrade the Cisco IMC firmware to the same version or the controller does not boot. Do not power off the controller until the BIOS and Cisco IMC firmware are matching or the controller does not boot.

Cisco provides the Cisco Host Upgrade Utility to assist with simultaneously upgrading the BIOS, Cisco IMC, and other firmware to compatible levels.

**Warning**

After the firmware is upgraded, do not reset the system to factory default. Doing so will delete the initial BIOS setup and boot orders.

The controller uses firmware obtained from and certified by Cisco. Cisco provides release notes with each firmware image.

The only supported method to update the firmware is using the Cisco Host Upgrade Utility.

Accessing System BIOS

-
- Step 1** Enter the BIOS setup utility by pressing the **F2** key when prompted during bootup.
- Note** The version and build of the current BIOS are displayed on the Main page of the utility.
- Step 2** Use the arrow keys to select the BIOS menu page.
- Step 3** Highlight the field to be modified by using the arrow keys.
- Step 4** Press **Enter** to select the field that you want to change, and then modify the value in the field.
- Step 5** Press the right arrow key until the Exit menu screen is displayed.
- Step 6** Follow the instructions on the Exit menu screen to save your changes and exit the setup utility (or press **F10**). You can exit without saving changes by pressing **Esc**.
-



APPENDIX **A**

Controller Specifications

This appendix lists the technical specifications for the controller.

- [Physical Specifications, page 21](#)
- [Environmental Specifications, page 21](#)
- [Power Specifications, page 22](#)

Physical Specifications

Table 5: Physical Specifications

Description	Specification
Height	1.7 in. (4.3 cm)
Width	16.9 in. (42.9 cm)
Depth	29.8 in. (75.8 cm)
Maximum weight (fully loaded chassis)	SFF 8-drive: 37.9 lb. (17.2 kg)

Environmental Specifications

Table 6: Environmental Specifications

Description	Specification
Temperature, operating	41 to 104°F (5 to 40°C) Derate the maximum temperature by 1°C per every 305 meters (1000 ft) of altitude above sea level.

Description	Specification
Temperature, non-operating(when the controller is stored or transported)	-40 to 149°F (-40 to 65°C)
Humidity (RH), noncondensing	10 to 90%
Altitude, operating	0 to 10,000 ft
Altitude, non-operating(when the controller is stored or transported)	0 to 40,000 ft
Sound power level Measure A-weighted per ISO7779 LwAd (Bels) Operation at 73°F (23°C)	5.4
Sound pressure level Measure A-weighted per ISO7779 LpAm (dBA) Operation at 73°F (23°C)	37

Power Specifications



Note Do not mix power supply types in the controller. Both power supplies must be identical.

770 W AC Power Supply

[Table 7: Power Supply Specifications](#), on page 22 lists the specifications for each 770 W AC power supply (Cisco part number UCSC-PSU1-770W).

Table 7: Power Supply Specifications

Description	Specification
AC input voltage range	90 to 264 VAC (Self-ranging, 100 to 264 VAC nominal)
AC input frequency	Range: 47 to 63 Hz (Single phase, 50 to 60Hz nominal)
AC line input current (steady state)	9.5 A peak at 100 VAC 4.5 A peak at 208 VAC

Description	Specification
Maximum output power for each power supply	770 W
Power supply output voltage	Main power: 12 VDC Standby power: 12 VDC



Power Cord Specifications

This appendix provides supported power cable specifications.

- [Supported Power Cords and Plugs](#), page 25
- [AC Power Cord Illustrations](#), page 28

Supported Power Cords and Plugs

Each power supply has a separate power cord. Standard power cords or jumper power cords are available for connection to the controller. The jumper power cords, for use in racks, are available as an optional alternative to the standard power cords.



Note

Only the approved power cords or jumper power cords provided with the controller are supported.

Table 8: Supported Power Cords for the Controller

Description	Feet	Meters	Power Cord Reference Illustration
SFS-250V-10A-AR Power Cord, 250 VAC 10 A IRAM 2073 Plug Argentina	8.2	2.5	Figure <i>SFS-250V-10A-AR</i>
CAB-9K10A-AU 250 VAC 10 A 3112 Plug Australia	8.2	2.5	Figure <i>CAB-9K10A-AU</i>

Description	Feet	Meters	Power Cord Reference Illustration
SFS-250V-10A-CN Power Cord, 250 VAC 10 A GB 2009 Plug China	8.2	2.5	Figure <i>SFS-250V-10A-CN</i>
CAB-9K10A-EU Power Cord, 250 VAC 10 A M 2511 Plug Europe	8.2	2.5	Figure <i>CAB-9K10A-EU</i>
SFS-250V-10A-ID Power Cord, 250 VAC 16A EL-208 Plug South Africa, United Arab Emirates, India	8.2	2.5	Figure <i>SFS-250V-10A-ID</i>
SFS-250V-10A-IS Power Cord, 250 VAC 10 A SI32 Plug Israel	8.2	2.5	Figure <i>SFS-250V-10A-IS</i>
CAB-9K10A-IT Power Cord, 250 VAC 10 A CEI 23-16 Plug Italy	8.2	2.5	Figure <i>CAB-9K10A-IT</i>
CAB-9K10A-SW Power Cord, 250 VAC 10 A MP232 Plug Switzerland	8.2	2.5	Figure <i>CAB-9K10A-SW</i>
CAB-9K10A-UK Power Cord, 250 VAC 10 A BS1363 Plug (13 A fuse) United Kingdom	8.2	2.5	Figure <i>CAB-9K10A-UK</i>
CAB-AC-250V/13A Power Cord, 250 VAC 13 A IEC60320 Plug North America	6.6	2.0	Figure <i>CAB-AC-250V/13A</i>

Description	Feet	Meters	Power Cord Reference Illustration
CAB-N5K6A-NA Power Cord, 250 VAC 13 A NEMA 6-15 Plug, North America	8.2	2.5	Figure <i>CAB-N5K6A-NA</i>
CAB-9K12A-NA Power cord, 125 VAC, 13 A, NEMA 5-15 Plug North America	8.2	2.5	Figure <i>CAB-9K12A-NA</i>
CAB-C13-CBN Cabinet Jumper Power Cord, 250 VAC 10 A, C13-C14 Connectors	2.2	0.68	Figure <i>CAB-C13-CBN, Jumper Power Cord (0.68 m)</i>
CAB-C13-C14-2M Cabinet Jumper Power Cord, 250 VAC 10 A, C13-C14 Connectors	6.6	2.0	Figure <i>CAB-C13-C14-2M, Jumper Power Cord (2 m)</i>
CAB-C13-C14-AC Cabinet Jumper Power Cord, 250 VAC 10 A, C13-C14 Connectors	9.8	3.0	Figure <i>CAB-C13-C14-AC, Jumper Power Cord (3 m)</i>

AC Power Cord Illustrations

This section includes the AC power cord illustrations. See *SFS-250V-10A-AR* to *CAB-C13-C14-AC, Jumper Power Cord (3 m)*.

Figure 11: SFS-250V-10A-AR

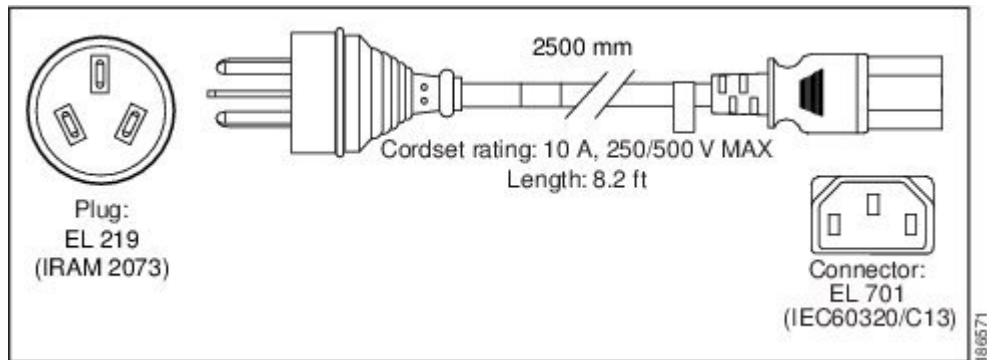

Figure 12: CAB-9K10A-AU

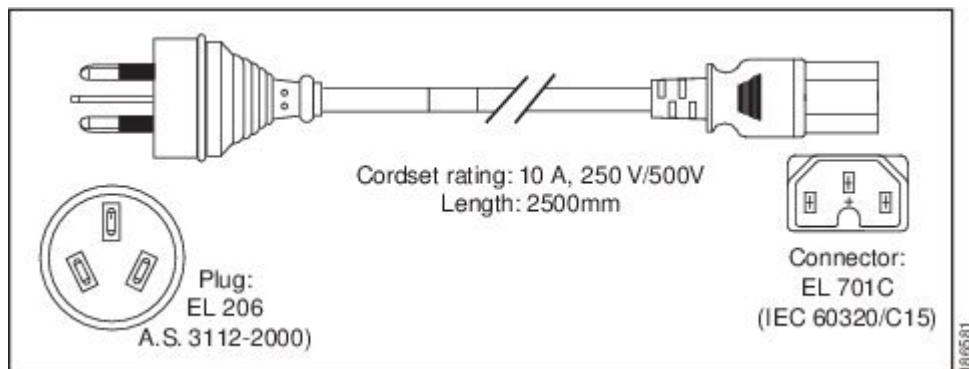

Figure 13: SFS-250V-10A-CN

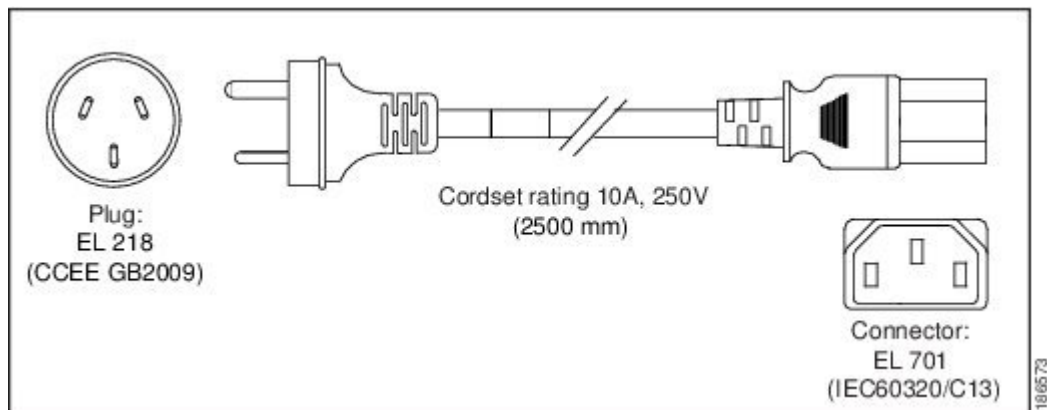

Figure 14: CAB-9K10A-EU

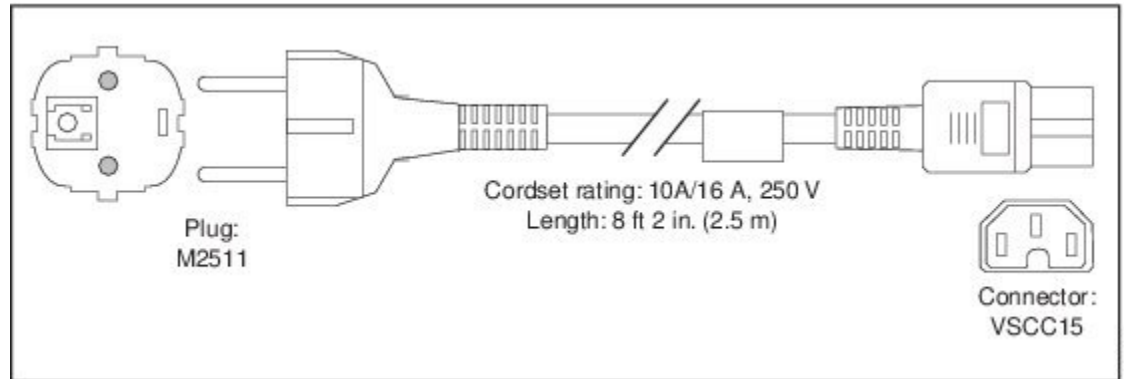

Figure 15: SFS-250V-10A-ID

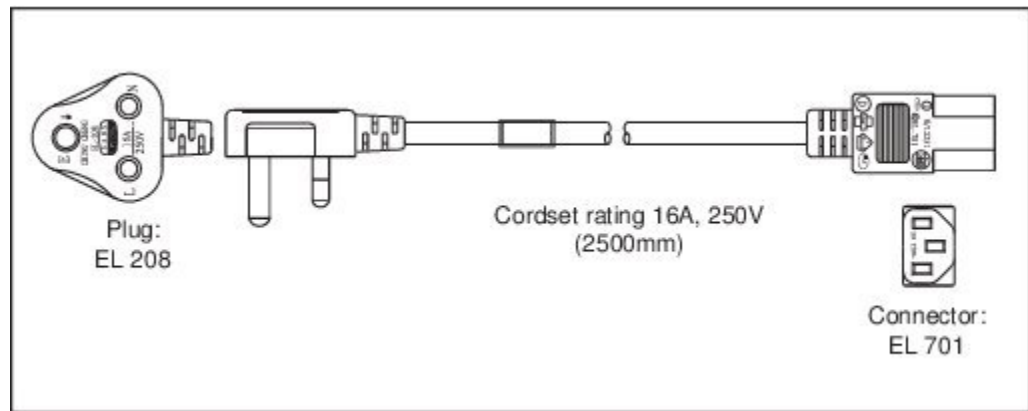

Figure 16: SFS-250V-10A-IS

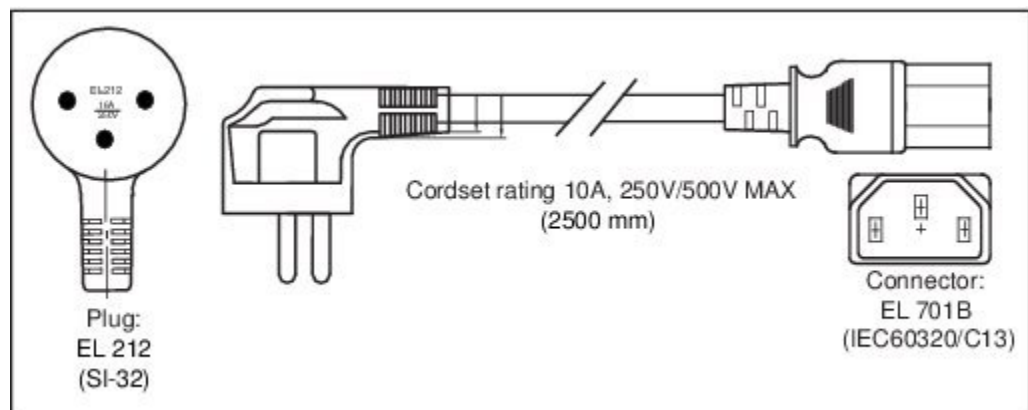

Figure 17: CAB-9K10A-IT

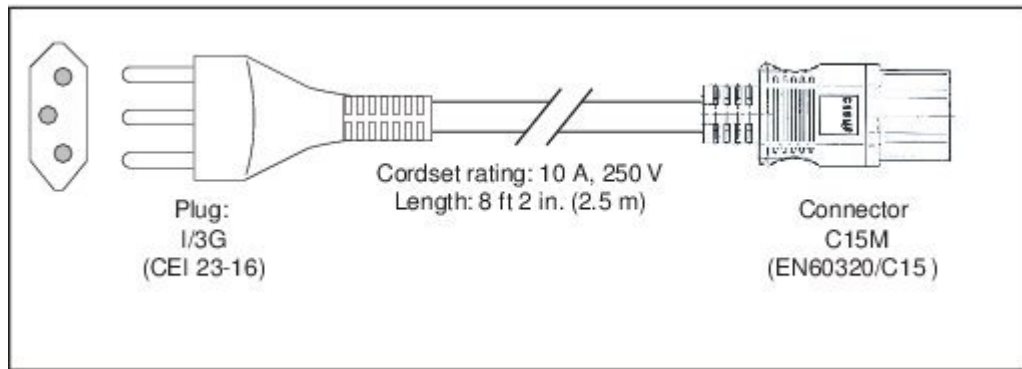

Figure 18: CAB-9K10A-SW

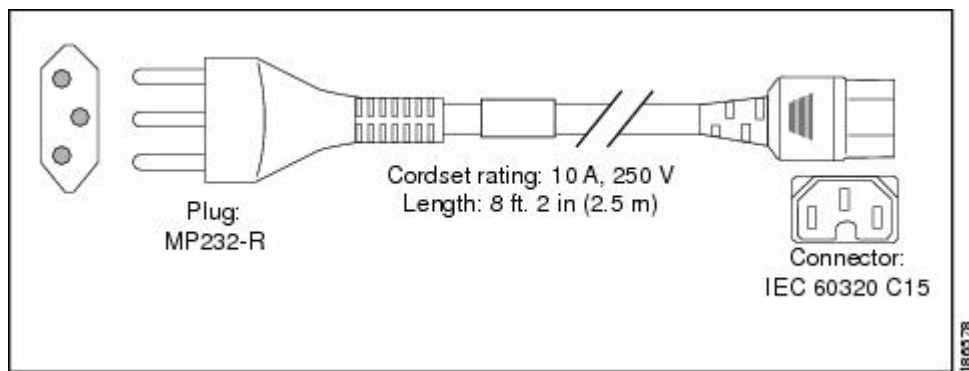

Figure 19: CAB-9K10A-UK

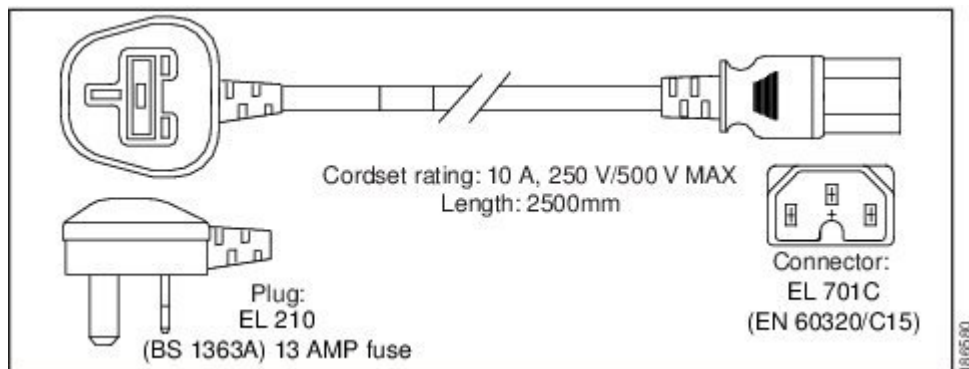

Figure 20: CAB-AC-250V/13A

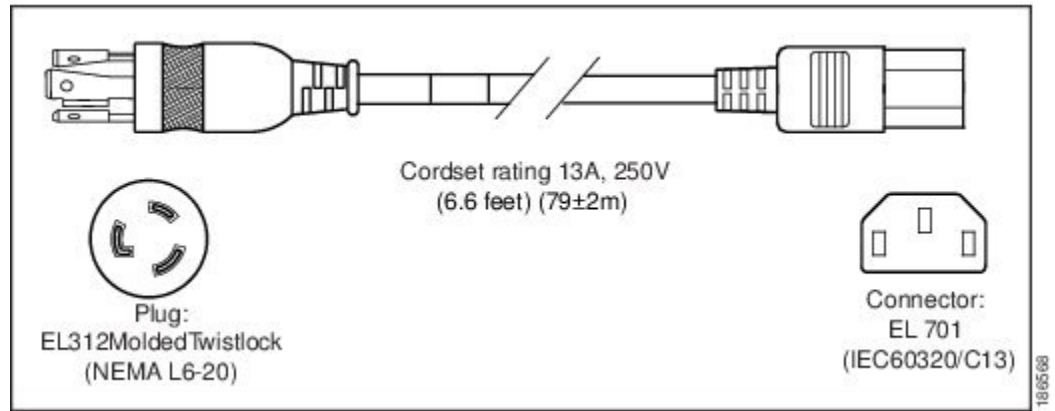

Figure 21: CAB-N5K6A-NA

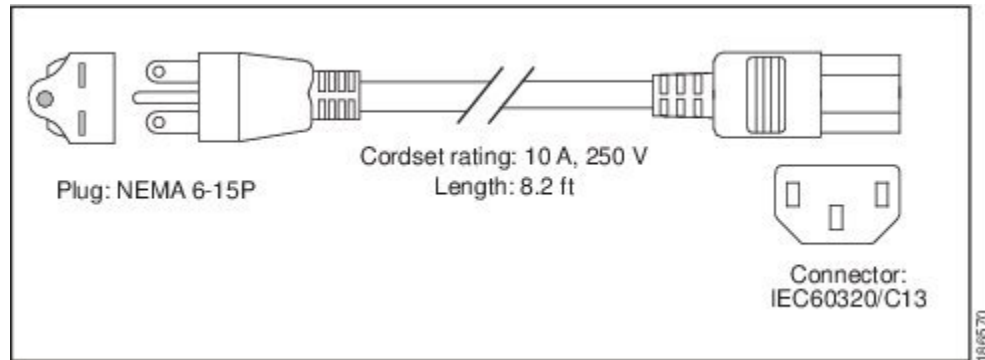

Figure 22: CAB-9K12A-NA

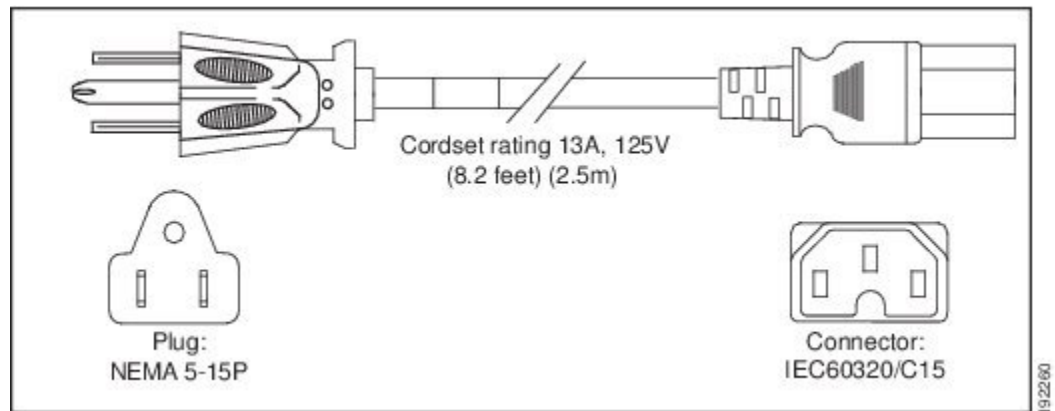

Figure 23: CAB-C13-CBN, Jumper Power Cord (0.68 m)

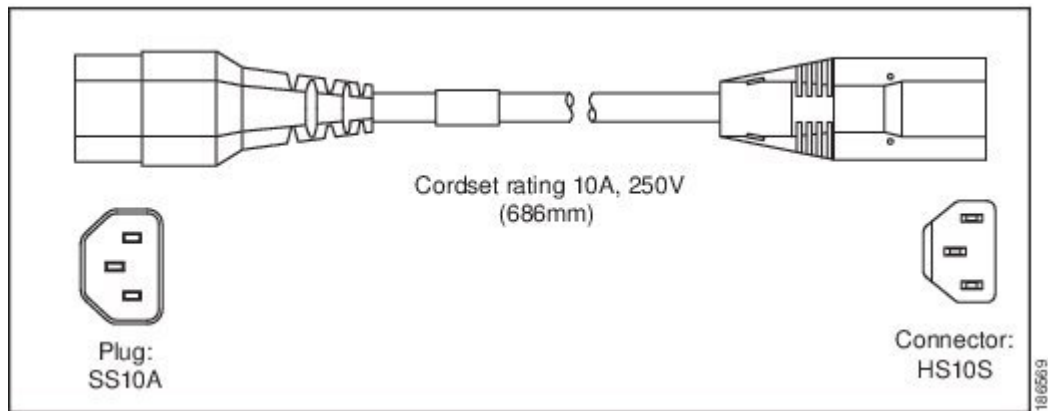

Figure 24: CAB-C13-C14-2M, Jumper Power Cord (2 m)

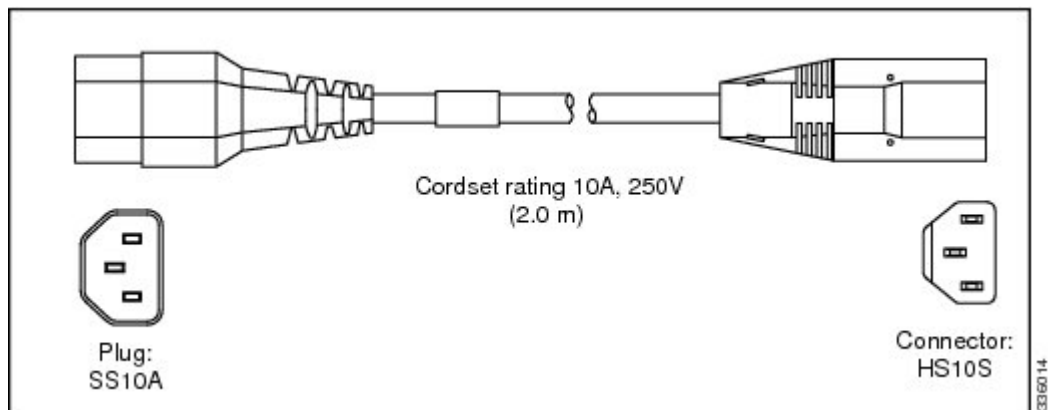
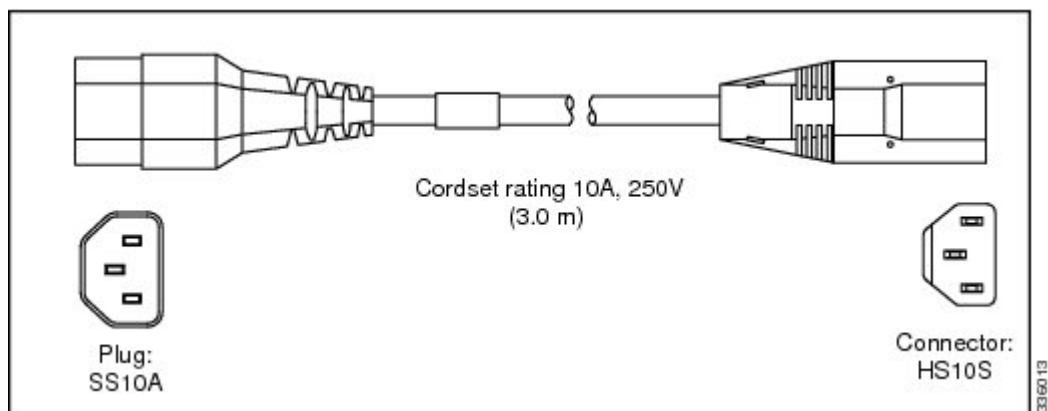

Figure 25: CAB-C13-C14-AC, Jumper Power Cord (3 m)





INDEX

B

- BIOS [19](#)
 - using the setup utility [19](#)

C

- CIMC firmware, updating [19](#)

E

- environmental specifications [21](#)

F

- firmware [19](#)
 - updating CIMC [19](#)

I

- initial power-on and setup (standalone) [18](#)
- installation [12](#), [13](#), [18](#)
 - initial power-on and setup (standalone) [18](#)
 - preparing for installation [12](#)
 - rack installation [13](#)

- installation (*continued*)

- rack requirements [13](#)
- required equipment [13](#)
- site preparation guidelines [12](#)

P

- physical specifications [21](#)
- power [22](#)
 - specifications [22](#)
- preparing for server installation [12](#)

R

- rack installation [13](#)
- rack requirements [13](#)
- required equipment [13](#)
 - installation [13](#)

S

- site preparation guidelines [12](#)
- specifications [21](#), [22](#)
 - environmental [21](#)
 - physical [21](#)
 - power [22](#)

