

INSTRUCTION MANUAL

Speco 3MP-TVI IR Series

HT7043T

(IR Bullet Camera)

HT5943T

(IR Dome Camera)



Contents

● Contents.....	1
● Precautions	2-3
● Safety Instructions	4
● Package Contents.....	5
● Camera Installation	6-9
● Lens Adjustment	10-11
● Specifications.....	12-13
● Camera Dimension	14
● Features.....	15
● OSD Menu Details	16-29
● Trouble Shooting.....	30

Precautions

Do not install the camera in extreme temperature conditions.

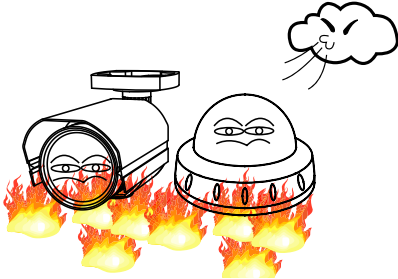

Only use the camera under conditions where temperatures are between -10°C and $+50^{\circ}\text{C}$. Be especially careful to provide ventilation when operating under high temperatures.

Do not install the camera under unstable lighting conditions.

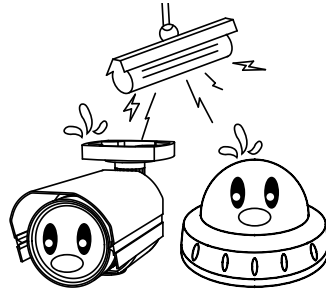

Severe lighting change or flicker can cause the camera to work improperly.

Do not touch the front lens of the camera.

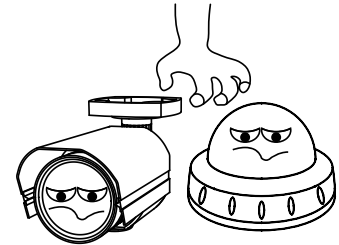

This is one of the most important parts of the camera. Be careful not to leave fingerprints on the lens cover.

Never keep the camera pointed directly at strong light.

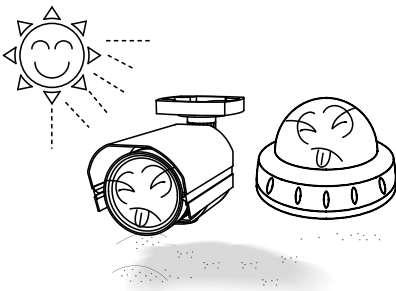

It can cause malfunctions to occur.

Do not drop the camera or subject it to physical shocks.

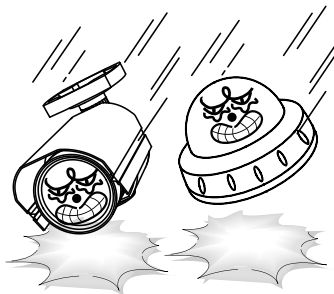

Housing damage can compromise weatherproof ratings.

Do not expose the camera to radioactivity.

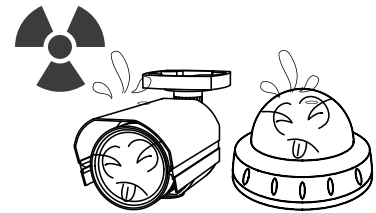

If exposed to radioactivity the CCD will fail.

NOTE

* If the camera is exposed to spotlight or object reflecting strong light, smear or blooming may occur.

* please check that the power satisfies the normal specification before connecting the camera.

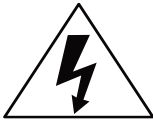

The lightning flash with an arrowhead symbol, within an equilateral triangle is intended to alert the user to the presence of uninsulated dangerous voltage within the product's enclosure that may be of sufficient magnitude to constitute a risk of electric shock to persons.



The exclamation point within an equilateral triangle is intended to alert the user to the presence of important operating and maintenance (servicing) instructions in the literature accompanying the appliance.

In USA and Canada, Use Class 2 Power Supply Only

INFORMATION - This equipment has been tested and found to comply with limits for a Class A digital device, pursuant to part 15 of the FCC Rules & CE Rules. These limits are designed to provide reasonable protection against harmful interference when the equipment is operated in a commercial environment. This equipment generates, uses, and can radiate radio frequency energy and, if not installed and used in accordance with the instruction manual, may cause harmful interference to radio communications. Operation of this equipment in a residential area is likely to cause harmful interference in which case the user will be required to correct the interference at their own expense.

WARNING - Changes or modifications not expressly approved by the manufacturer could void the user's authority to operate the equipment.

WARNING - To prevent electric shock and risk of fire hazards:

- ◆ Do NOT use power sources other than that specified.
- ◆ Do NOT expose this appliance to rain or moisture.

Apparatus shall not be exposed to dripping or splashing and no objects filled with liquids, such as vases, shall be placed on the apparatus.

CAUTION : To prevent electric shock and risk of fire hazards:

- ☞ Do NOT use power sources other than those specified.

Safety Instructions

Precautions for use

- ① This camera should be installed by qualified personnel only
- ① There are no user serviceable parts inside
- ① Do not disassemble this camera other than to make initial adjustments
- ① Use a UL approved regulated 24 volt AC or 12 volt DC power supply
- ① Use appropriate low voltage power cable to prevent fire or electrical shock
- ① Please insure that your installation area can support the weight of the camera

Please handle this camera carefully :

- ① Do not use a strong or abrasive detergent when cleaning the camera
- ① Do not install near cooling or heating device

Package Contents

Please make sure that the following items are included in the Package:

- 1) HT7043T
 - 1 Video Test Connector, Power Jack
 - 1 Focus Adjustment
 - 1 Bracket Base
 - 1 Wrench
 - Set Screw
 - 4 Tapping Screws 4x25
 - 4 Hexagon Socket Screws M5x10

- 2) HT5943T
 - 1 Video Test Connector, Power Jack
 - 1 Chameleon Cover
 - 1 Wrench
 - Set Screw
 - 3 Tapping Screws 3.5x20

CAMERA INSTALLATION

CONNECT POWER CABLE

1. WHEN USING 12 VOLTS DC (constant voltage 500mA)

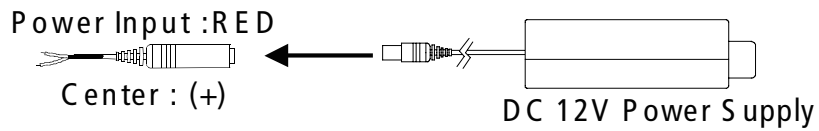

2. WHEN USING 24 VOLTS AC (40 Volt Amps)

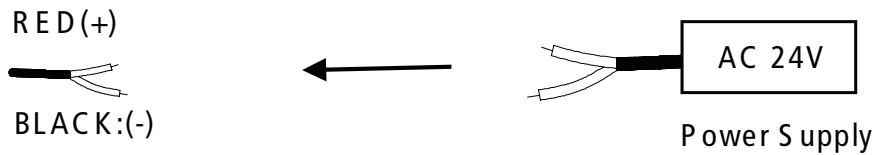

3. CONNECT VIDEO CABLE

CONNECT BLACK COLOR BNC CABLE TO THE BNC JACK.

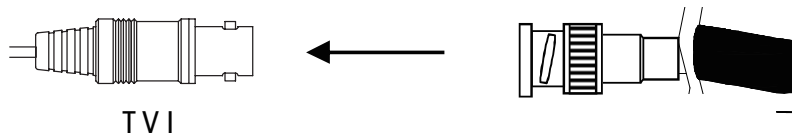

CAMERA INSTALLATION

Compatibility

1) HT7043T

CVCJBB

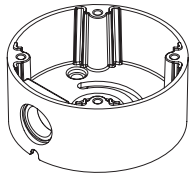

INTJBS

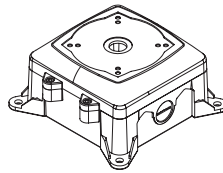

INTCM

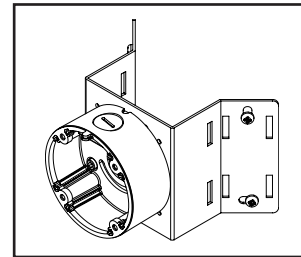
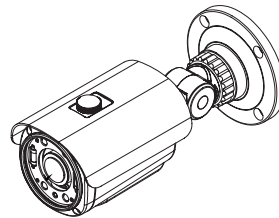
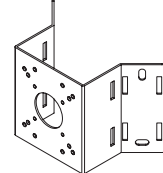

2) HT5943T

CVCJBD

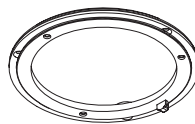
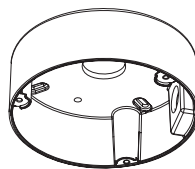

→ Adaptor plate(59PLATE) with rubber

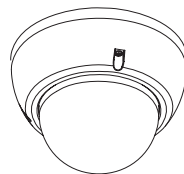

CAUTION : The installation instructions in this manual are for use by qualified service personnel only. To reduce the risk of electric shock, do not perform any servicing other than that contained in the operating instructions unless you are qualified to do so.

CAMERA INSTALLATION

1. HT7043T

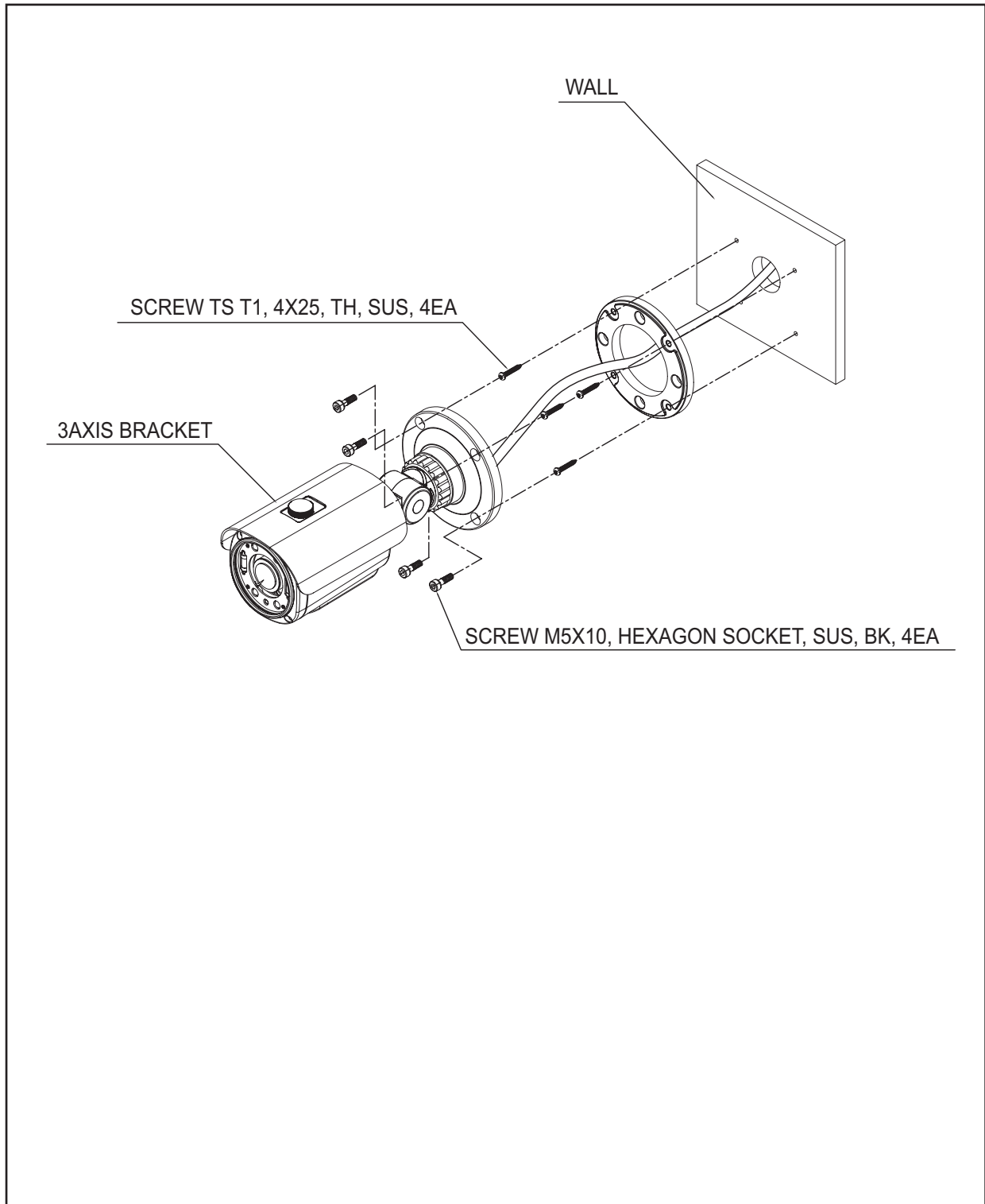

CAMERA INSTALLATION

2. HT5943T

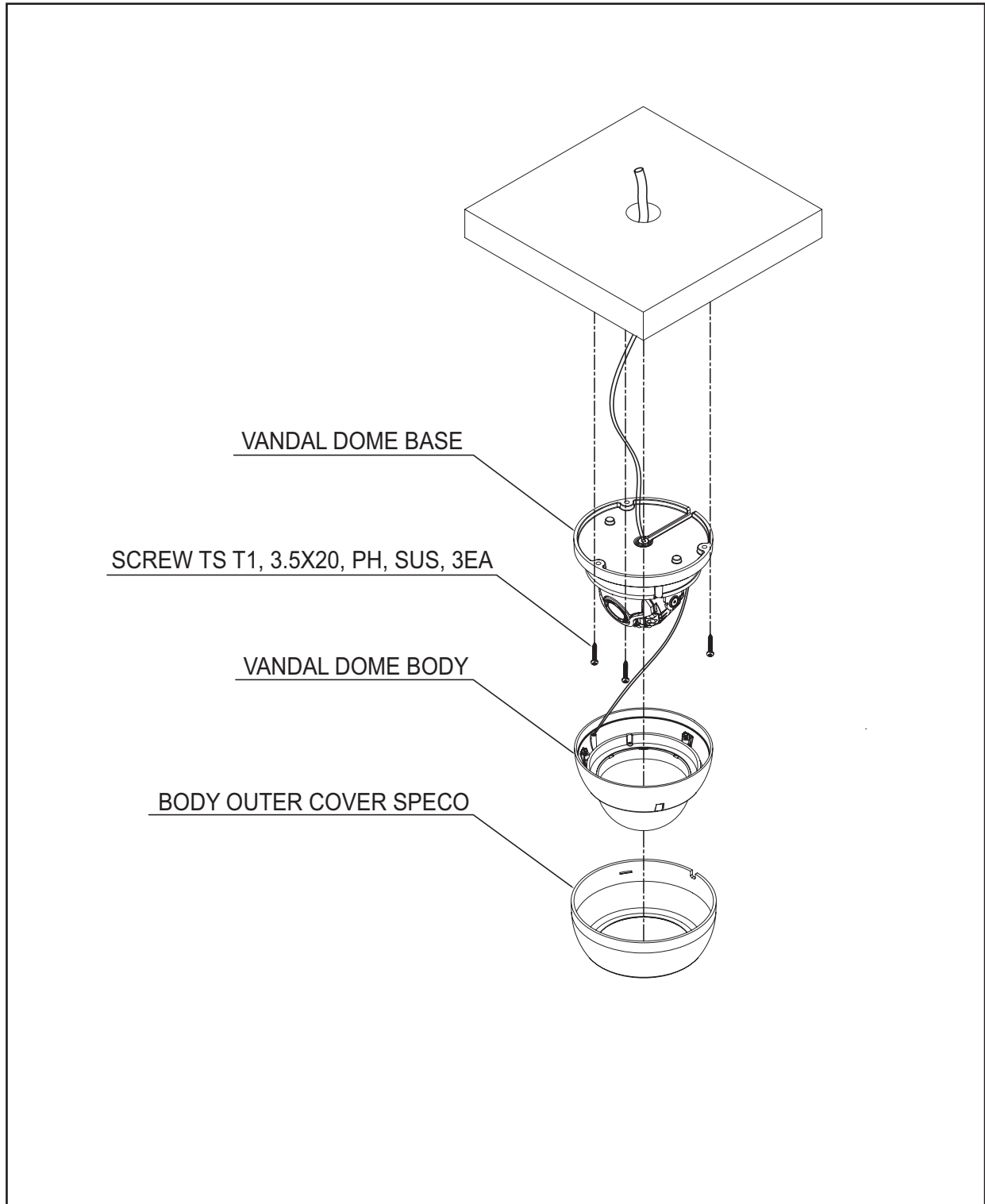

LENS ADJUSTMENT

1. HT7043T

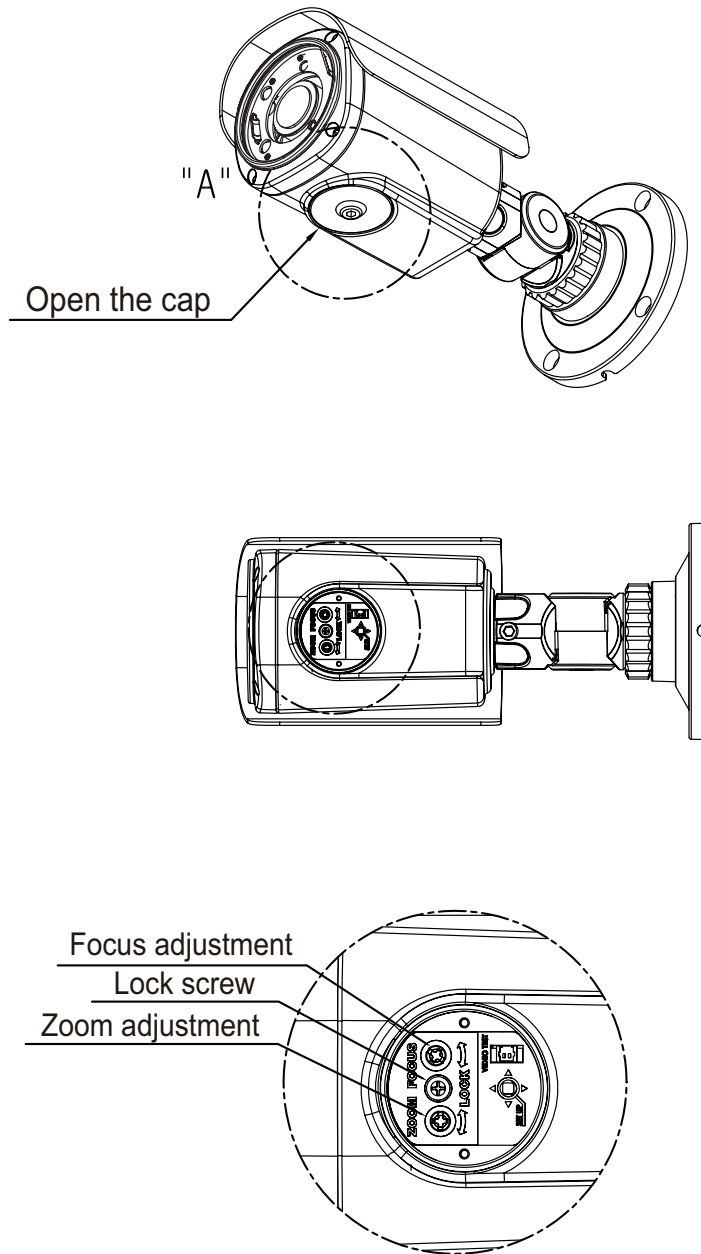

LENS ADJUSTMENT

2. HT5943T

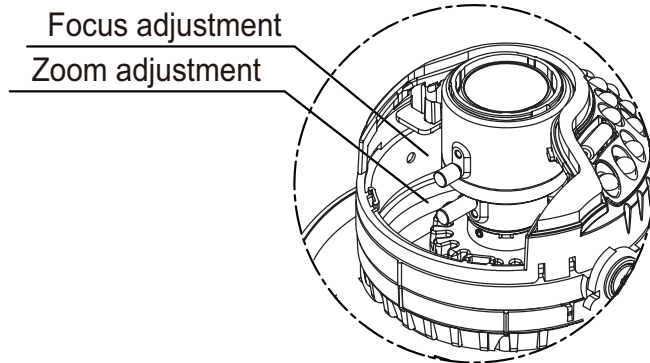
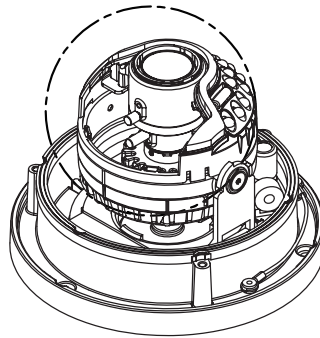
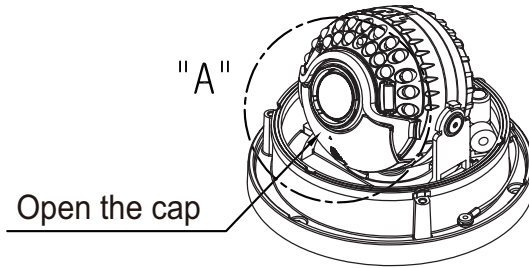

Speco 3MP-TVI IR Series

DC Auto Iris Varifocal Lens 2.8-12mm



HT7043T (2.8-12mm)



SPECIFICATIONS

MODEL	HT7043T
Image Sensor	1/2.8" SONY 3Mega Exmor CMOS Sensor
Effective pixels	2065(H) X 1553(V), 3.21M Pixels
Total pixels	2065(H) X 1565(V), 3.23M Pixels
Resolution	2048X1536(1536p@18.75f)
Scanning system	Progressive Scan
Min. illumination	B/W : 0.5Lux @ F1.4 (AGC Max) 0.01Lux @ F1.4 (AGC Max, Sens-up Max)
Video Output	1.0Vp-p TVI(Transport Video Interface) 75 Ohms
S/N Ratio	More than 50dB
Lens	DC Auto Iris Varifocal Lens(2.8mm-12mm)
AGC	0~20 Level Adjustable
Shutter Speed	AUTO / Manual(1/18.75Sec~1/9,600Sec) / FLICKER
Brightness	0~20 Level Adjustable
Sens-UP	OFF / x2~x32
Backlight Compensation(BLC)	OFF/ON
HSBLC	OFF/ON
ACE(D-WDR/ART-EX)	OFF/LOW/MIDDLE/HIGH
Motion Detection\	OFF/ON(4Zone)
Alam Output	Option
Privacy Masking	OFF/ON(16Zone)
Day & Night	AUTO / COLOR / B&W / EXTERN
Smart-IR(IR OPTIMIZER)	0~20 Level Adjustable
White Balance	AUTO(2,500K ~ 9,500K) / AWC →Set / Manual / AWB
Digital Noise Reduction	2D, 3DNR(CVBS OFF)
Mirror	MIRROR , V-FLIP
D-ZOOM(EZOOM)	OFF/ON (x2 ~ x8)
Sharpness	0~20 Level Adjustable
DEFOG	OFF/ON
GAMMA Correction	r=0.45~0.65
Language	EBG/KOR/CHN1/CHA2/JPN
Defect(White pix mask)	AUTO / Manual(1042EA)
CVBS	ON(DNR:OFF / SEN-UP:OFF / Flip:OFF / D-ZOOM:OFF)OFF
Power Source	DUAL
Power Consumption	DC 12V: 770mA(LED ON) / 350mA(LED OFF) AC 24V: 310mA(led on) / 180mA(LED OFF)
Storage Temperature	-20°C ~ +60°C(Humidity : 20%RH ~ 95%RH)
Operating Temperature	-10°C ~ +50°C(Humidity : 20%RH ~ 80%RH)
Dimensions(WxHxD) or ØxH	3.94" (W)*3.94" (H)*8.27" (D)
Unit Weight	3.09lbs

Speco 3MP-TVI IR Series

DC Auto Iris Varifocal Lens 2.8-12mm



■ HT5943T (2.8-12mm)

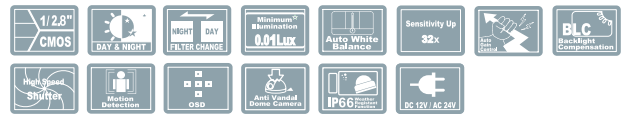

SPECIFICATIONS

MODEL	HT5943T
Image Sensor	1/2.8" SONY 3Mega Exmor CMOS Sensor
Effective pixels	2065(H) X 1553(V), 3.21M Pixels
Total pixels	2065(H) X 1565(V), 3.23M Pixels
Resolution	2048X1536(1536p@18.75f)
Scanning system	Progressive Scan
Min. illumination	B/W : 0.5Lux @ F1.4 (AGC Max) 0.01Lux @ F1.4 (AGC Max, Sens-up Max)
Video Output	1.0Vp-p TVI(Transport Video Interface) 75 Ohms
S/N Ratio	More than 50dB
Lens	DC Auto Iris Varifocal Lens(2.8mm-12mm)
AGC	0~20 Level Adjustable
Shutter Speed	AUTO / Manual(1/18.75Sec~1/9,600Sec) / FLICKER
Brightness	0~20 Level Adjustable
Sens-UP	OFF / x2~x32
Backlight Compensation(BLC)	OFF/ON
HSBLC	OFF/ON
ACE(D-WDR/ART-EX)	OFF/LOW/MIDDLE/HIGH
Motion Detection\	OFF/ON(4Zone)
Alam Output	Option
Privacy Masking	OFF/ON(16Zone)
Day & Night	AUTO / COLOR / B&W / EXTERN
Smart-IR(IR OPTIMIZER)	0~20 Level Adjustable
White Balance	AUTO(2,500K ~ 9,500K) / AWC →Set / Manual / AWB
Digital Noise Reduction	2D, 3DNR(CVBS OFF)
Mirror	MIRROR , V-FLIP
D-ZOOM(EZOOM)	OFF/ON (x2 ~ x8)
Sharpness	0~20 Level Adjustable
DEFOG	OFF/ON
GAMMA Correction	r=0.45~0.65
Language	EBG/KOR/CHN1/CHA2/JPN
Defect(White pix mask)	AUTO / Manual(1042EA)
CVBS	ON(DNR:OFF / SEN-UP:OFF / Flip:OFF / D-ZOOM:OFF)OFF
Power Source	DUAL
Power Consumption	DC 12V: 560mA(LED ON) / 350mA(LED OFF) AC 24V: 250mA(led on) / 180mA(LED OFF)
Storage Temperature	-20°C ~ +60°C(Humidity : 20%RH ~ 95%RH)
Operating Temperature	-10°C ~ +50°C(Humidity : 20%RH ~ 80%RH)
Dimensions(WxHxD) or ØxH	4.72" (Dia)*3.35" (H)
Unit Weight	2.20lbs

CAMERA DIMENSION

1) HT7043T

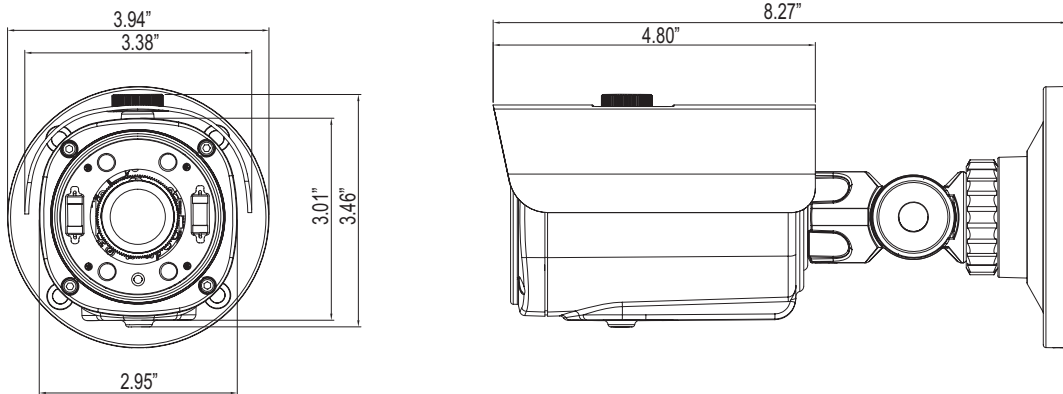

2) HT5943T

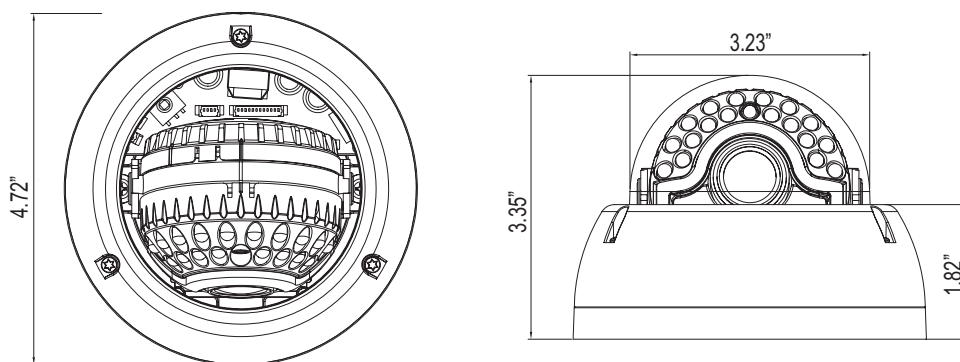

General Features

● Transfer Video Interface

The combination of a 3Mega CMOS image sensor and TVI DSP provides an excellent resolution of TVI picture.

● 3D-DNR

Smart 3DNR prevents the image blurring of moving object and activates only if moving objects are appearing on the scene.

● Smart-IR

No saturation image, vivid image in darkness! "TVI" camera makes very sharp video image in darkness! This technology eliminates saturation of video image of the closer object in darkness by control of the IR sensitivity. Saturation never happens in our "TVI" cameras, you can enjoy vivid image in any dark condition!

● Sens-Up

Despite a limited & low light condition, Sens-Up - Max. x32 helps the viewer to get visible and clear images.

● Defog

Defog function improve the clarity of images taken in poor conditions such as fog, smoke, rain or snow.

● Intelligent Function

An extra ordinary technology enables Speco Technologies TVI become an ultimate and of solution by providing intelligent features based on motion detection. It strengthens crime prevention and detection.

How to Set Up the camera menu

● Setup Menu

MENU				
1.LENS	DC	MODE	INDOOR / OUTDOOR / DEBLUR	
		RETURN		
	MANUAL	MODE	NORMAL / DEBLUR	
		RETURN		
2.EXPOSURE		BRIGHTNESS	0~20	
		SHUTTER	AUTO	
			MANUAL	SPEED 1/18.75~1/9600
			RETURN	
			FLICKER	
		SENS-UP	OFF ~ X32	
		AGC	0~20	
		RETURN		
3.WHITE BAL	AUTO			
	AWB			
	AWC-SET			
	MANUAL	KELVIN	LOW / MIDDLE / HIGH	
		R-GAIN	0 ~ 20	
B-GAIN		0 ~ 20		
		RETURN		
4.BACKLIGHT	OFF			
	HLC	LEVEL	0 ~ 20	
		MODE	ALL DAY / NIGHT ONLY	
		RETURN		
	BLC	H-POS	0 ~ 18	
		V-POS	0 ~ 17	
		H-SIZE	0 ~ 18	
V-SIZE		0 ~ 17		
		RETURN		
5.SPECO DNR	OFF / LOW / MIDDLE / HIGH			
6.DAY&NIGHT	AUTO	SMART IR	0~20	
		AGC THRES	0~20	
		AGC MARGIN	0~20	
		DELAY	LOW / MIDDLE / HIGH	
		RETURN		
	COLOR			
	B/W	SMART IR	0~20	
		RETURN		
	EXTERN	SMART IR	0~20	
		DELAY	LOW / MIDDLE / HIGH	
RETURN				
7.IMAGE		SHARPNESS	0 ~ 20	
		GAMMA	0.45 ~ 0.65	
		COLOR GAIN	0 ~ 20	
		MIRROR	ON/OFF	
		FLIP	ON/OFF	
		D-ZOOM	X 1.0 ~ X8.0	
		ACE	LOW/MIDDLE/HIGH	
		DEFOG	OFF	
			ON	MODE AUTO / MANUAL
			RETURN	LEVEL LOW / MIDDLE / HIGH

How to Set Up the camera menu

● Setup Menu

MENU					
7.IMAGE		PRIVACY	OFF		
			ON	ZONE NUM	0~15
				ZONE DISP	ON/OFF
				H-POS	0~64
				V-POS	0~46
				H-SIZE	0~65
				V-SIZE	0~47
				Y LEVEL	0~20
				CR LEVEL	0~20
				CB LEVEL	0~20
RETURN					
8.MOTION	OFF				
	ON	SENSITIVITY	0 ~ 20		
		DC MODE	1 ~ 6		
		WINDOW TONE	0 ~ 3		
		WINDOW USE	OFF/ON		
		DET H-POS	1 ~ 63		
		DET V-POS	1 ~ 47		
		DET H-SIZE	1 ~ 64		
		DET V-SIZE	1 ~ 48		
		ALARM	OFF/ON		
		RETURN			
9.SYSTEM	COM.	CAM ID	0 ~ 255		
		BAUDRATE	2400 / 4800 / 9600 / 57600 / 115200		
		RETURN			
	IMAGE RANGE	FULL			
		COMP			
		USER	OFFSET	0 ~ 20	
			RETURN		
	COLOR SPACE	YUV / SD-CBCR / HD-CBCR			
	VIDEO FREQ	PAL / NTSC			
	CVBS	OFF/ON			
	LANGUAGE	ENG / CHN / CHN(S) / JPN / KOR			
RESET	ON				
RETURN					
10.EXIT					

Menu Set Up

Menu setting can be selected by the button inside the camera.

1. Press the set button.

* The Set Up menu will be displayed on the monitor.

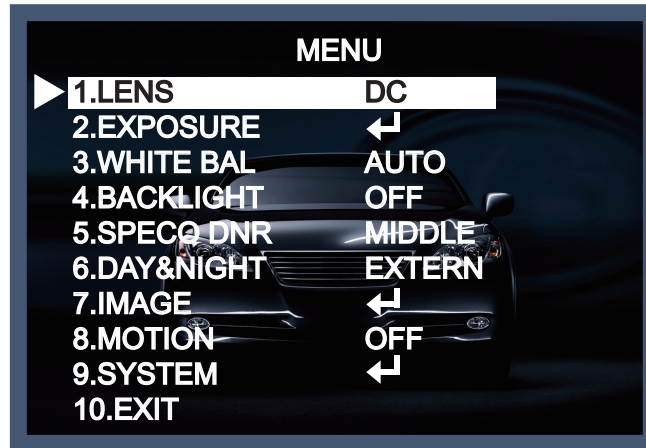

2. Move and select the required function using the Up and Down button.

* Move the triangular indicator Up or Down to select the desired feature by pressing the Up or Down button.



3. Change menu settings using the Left or Right button.

* Available values or Status are displayed by pressing the Left or Right buttons.

Press the button until desired value / status is displayed.

4. After Changing the setting move the arrow indicator to EXIT and press the SET button to EXIT.

NOTE

* Move to the available submenu by moving  arrow to desired feature.

LENS

1. Move the triangular indicator to LENS using the Up and Down buttons on the Set Up menu screen.
2. Select the desired lens type by pressing the Left of Right button.

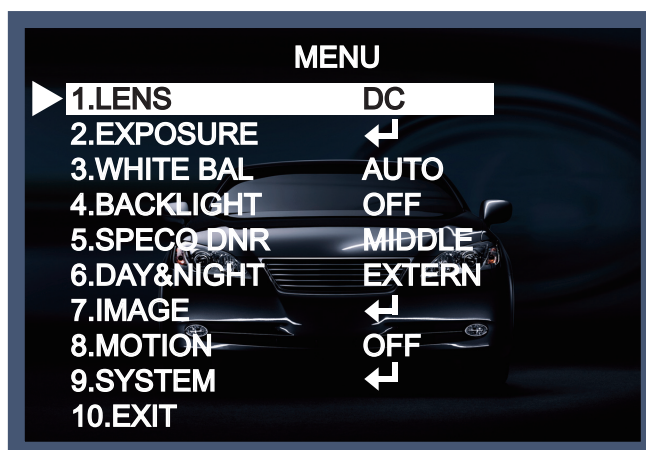

NOTE



- * When you select the mode setup, you can select INDOOR, OUTDOOR or DEBLUR depending on the installation environment.
- * On manual mode, you can select NORMAL or DEBLUR depending on the installation environment.

EXPOSURE

1. On the Set Up menu, Select EXPOSURE by using the Up or Down button.

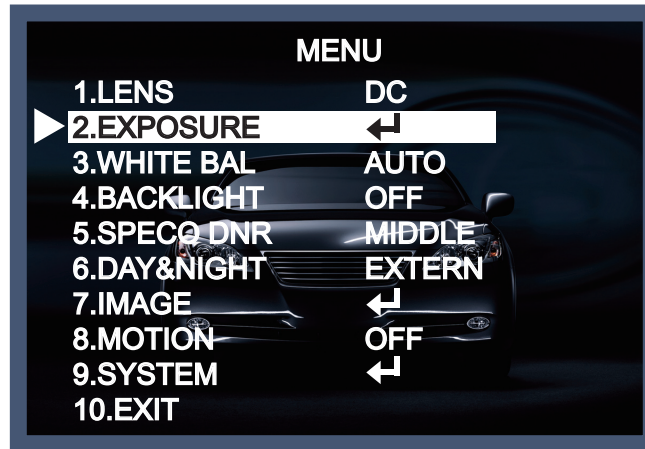

2. Select the desired shutter mode by pressing the Left or Right button.

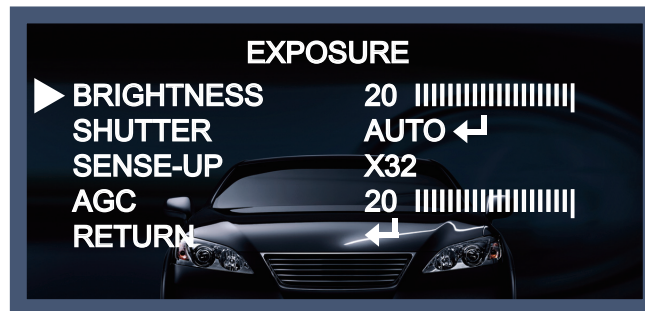

- ◆ BRIGHTNESS : The brightness can be adjusted. The brightness control range is 1~20.
- ◆ SHUTTER : DC lens is launched with the setting of 1/30 and the manual lens is launched with the setting of Auto shutter, but the shutter speed can be adjusted from 1/30 to 1/30,000.
 - FLK : Select FLK mode if flickering occurs ; caused by the unmatched frequency of electric light.
- ◆ SENSE-UP : The bright screen can be displayed by sensing the degree of the darkness automatically under the circumstance of low light condition or at night.
 - Off ~x32 Level Adjustable.
- ◆ AGC (Auto Gain Control) : The higher the AGC level is, the more noises appear.
 - 0~20 Level selectable.

NOTE

* Sense-Up mode is not worked when Electronic shutter is selected as Manual.

White Balance

Use this function when the color adjustment of a screen is needed.

1. Move the triangular indicator to WHITE BAL on the SETUP menu screen using the Up and Down button.
2. Select the desired mode by using the left or Right button.

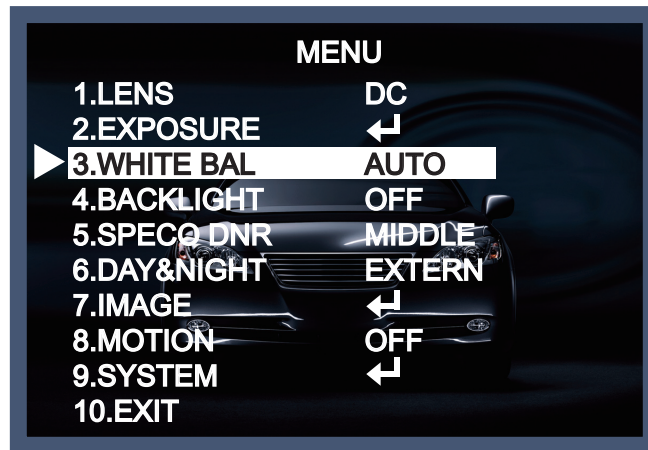

- ◆ AUTO : Use this mode when the color temperature is from 2,500k to 9,500k.
- ◆ AWB : The function to search for the color which is matched well with the ambient environment.
- ◆ AWC→SET : After letting camera focus on the blank white paper to the best condition of current lighting environment, press the SET button. If the lighting condition is changed, Re-adjustment should be needed.
- ◆ MANUAL : Manual compensation make the more detailed control possible. First, after adjusting the white balance using the ATW or AWB mode, change the mode into the manual compensation mode and then press Set button. While looking at the color change of the subject seen on the screen after setting up the proper color temperature, increase the each value of the blue and the red.

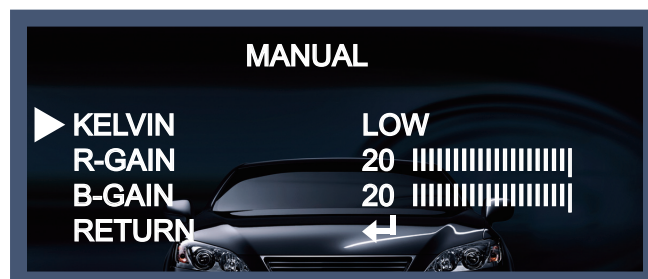

- KELVIN : LOW/MIDDLE/HIGH level adjustable.
- R-GAIN : 0~20 level adjustable.
- B-GAIN : 0~20 level adjustable.
- Return : Every function is set up at the EXPOSURE menu, and then return the previous menu.

NOTE

The White Balance may not be worked properly in the following conditions. If this doesn't work, use the AWB mode.

- * When there is a very high color temperature in the circumstances of the subject.
(for example, clear sky, Sunset)
- * It is very dark.
- * If the camera is headed to the fluorescent light directly or if there is a drastic lighting change, The operation of White balance may become unstable.

BACKLIGHT

On this menu, backlight image can be compensated by users selecting one of modes. (HLC, BLC, WDR)

1. Move the triangular indicator to BACKLIGHT on the SETUP menu screen using the Up and Down button.
2. Select the desired mode by using the left or Right button.

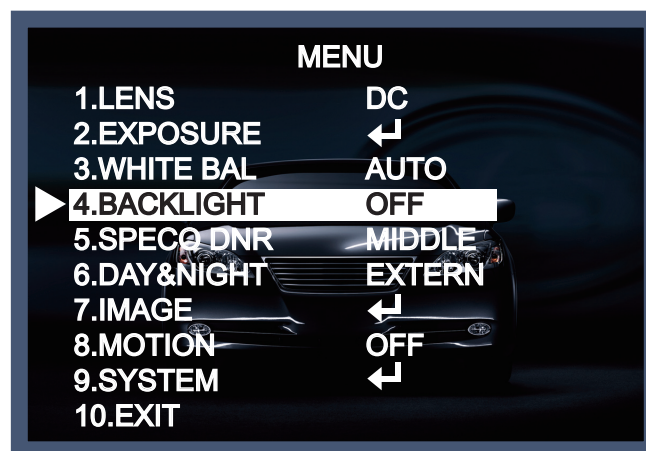

- ◆ Off : Deactivated status.
- ◆ HLC : This function is used to suppress or strong light source (for example, headlights of cars during nighttime) so that other subjects can be seen in more detail. If you select HCL, a submenu appears where you can make finer adjustments.
 - LEVEL : Adjust the brightness level from which on the light source is to be masked out.
0~20 level adjustable.
 - MODE : All day/night only adjustable.



- ◆ BLC : This function is used to counterbalance the screen image by increasing the brightness so that a subject which appears dark due to a strong backlight can be displayed in more detail. If you select BLC, a submenu appears where you can make finer adjustments.
- H-POS/V-POS/H-SIZE/V-SIZE : Define the position and size of the area of interest by changing the position & size.

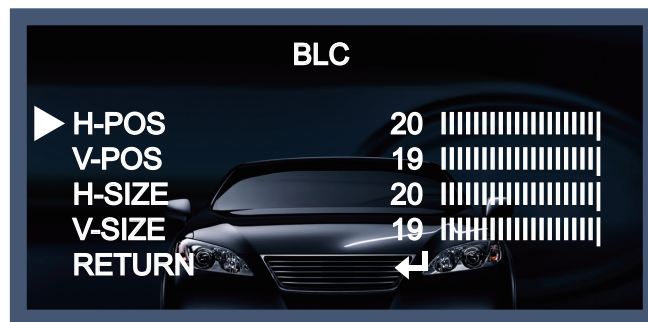

- ◆ WDR : The WDR (Wide Dynamic Range) function works to correct excessive light within the frame to produce a usable image. When the image has simultaneous bright and dark areas, it makes both areas distinct. If you select WDR, a submenu appears where you can make finer adjustments.
- WEIGHT [MIDDLE, HIGH, LOW] : Select the WDR level of the camera.



SPECO DNR

This function is used to improve the picture quality by filtering the noise which is generated under low brightness conditions. You can set different levels here.

1. Move the triangular indicator to DNR by using the Up and Down button.
2. Select the mode to use by pressing the left or Right button and OFF/LOW/MIDDLE/HIGH level selectable.



Day&Night

You can change the color mode of color or black / white by setting up the mode.

1. Select Day&Night using the Up or Down button on the Set Up menu screen.
2. Select the desired mode using the Left or Right buttons.

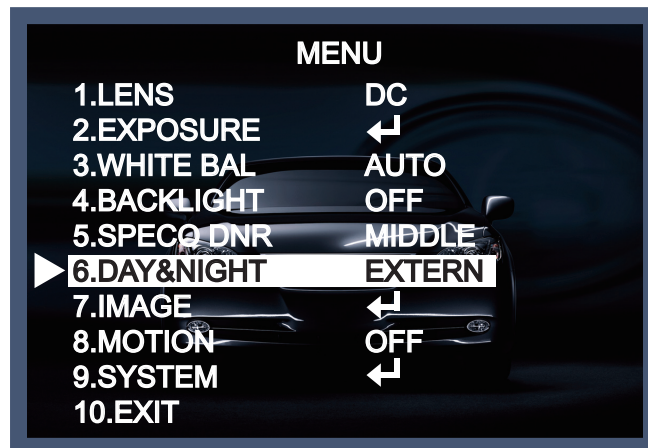

- ◆ **AUTO** : Automatically, It shifts into the color mode in the bright environment and the B/W mode in the low light condition. It can adjust the delay time, starting brightness and end brightness according to the ambient conditions by pressing the Set button.



- SMART-IR : 0~20 SMART-IR level adjustable.
- AGC THRES : 0~20 AGC THRES level adjustable.
- AGC MARGIN : 0~20 AGC MARGIN level adjustable.
- DELAY [LOW/MIDDLE/HIGH] : Set the delay time for switching between COLOR and B/W
- ◆ **COLOR** : Making the video output color always.
- ◆ **B / W** : Making the video output B/W always.
- ◆ **EXTERN** : It can change the color or B/W mode automatically through the connection with the ground terminal. (Option for box camera and IR camera)
- SMART-IR : It controls the IR LED (bright portion base), saturation is not expected. 0~20 level adjustable.



- DELAY [LOW/MIDDLE/HIGH] : Set the delay time for switching between color and B/W .

IMAGE

When selecting, the following submenu will appear.



Here you can optimize the image quality by adjusting different options.

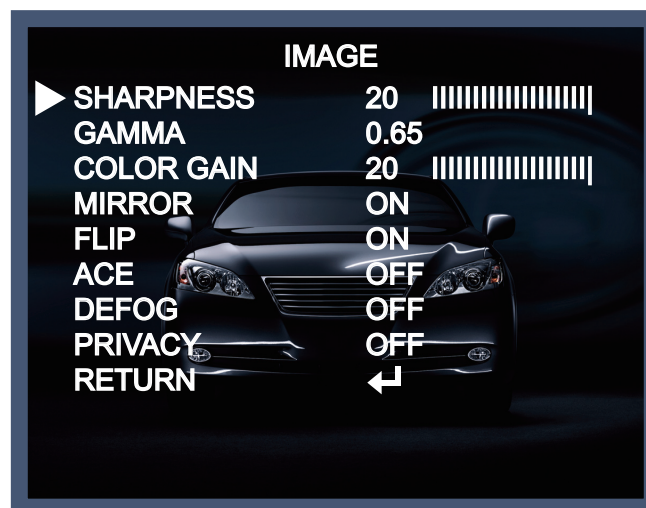

- ◆ SHARPNESS [0 ~ 20] : Adjusts the image sharpness. If the level goes up excessively, it may affect the video image and generate a noise.
- ◆ GAMMA [0.45 ~ 0.65] : Changes the gamma curve of the camera.
- ◆ COLOR GAIN [0 ~ 20] : Changes the color gain of the camera.
- ◆ MIRROR [ON, OFF] : Mirrors the image horizontally on the screen.
- ◆ FLIP [ON, OFF] : Flips the image vertically on the screen.
- ◆ ACE [OFF/LOW/MIDDLE/HIGH] : Intelligent lighting level control to over come even strong backlight conditions.
- ◆ DEFOG [ON, OFF] : This function helps to recognize the object in a dusty weather condition.
ON, a submenu appears where you can make finer adjustments.

- ◆ **PRIVACY [ON, OFF]** : This is used to hide certain areas on the monitor. You can designate each different 16 area. The size of a designated area can be adjusted. The color of a privacy area can be selected various colors. When you select the return, the setting values in this function menu are saved, then get out of this menu.

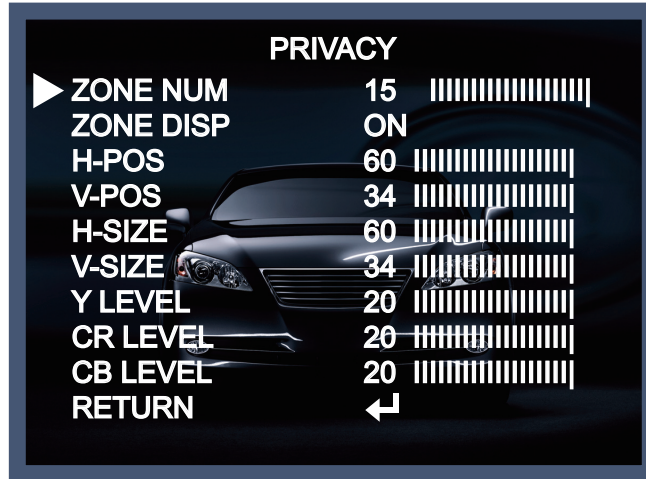

- ZONE NUM [0~15] : Select a mask out of the 16 mask areas and set the options below for the selected mask.
- ZONE DISP [ON, OFF] : Choose ON to activate privacy masks and press OFF to deactivate masks.
- H-POS [0~60] : Define the horizontal start position of the privacy mask.
- V-POS [0~34] : Define the vertical start position of the privacy mask.
- H-SIZE [0~60] : Define the horizontal size of the privacy mask.
- V-SIZE [0~34] : Define the vertical size of the privacy mask.
- Y LEVEL [0~20] : Define the brightness of the mask color.
- CR LEVEL [0~20] : Define the red amount of the mask color.
- CB LEVEL [0~20] : Define the blue amount of the mask color.

MOTION

This function is used to detect moving objects in the monitored area. When choosing ON, the following submenu will appear where you can adjust the settings for the MOTION function.

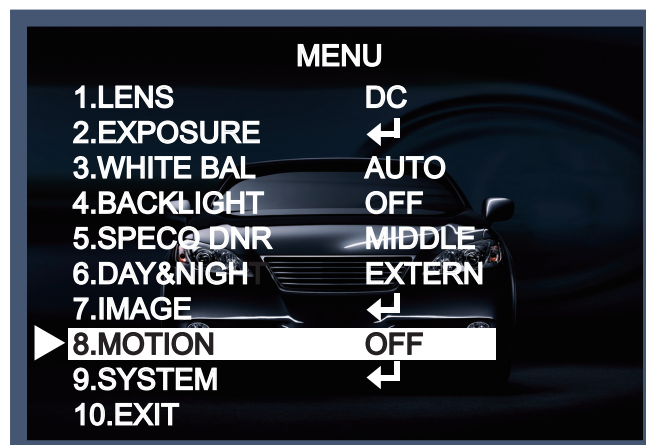

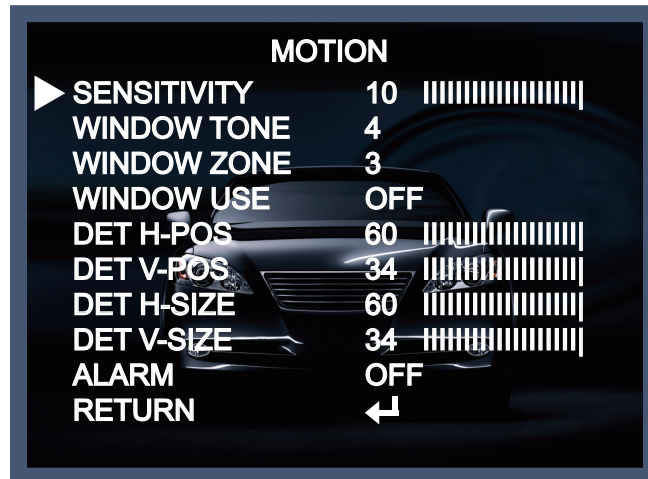

- ◆ SENSITIVITY [0~10] : The higher the setting value is, the higher the sensitivity gets, even though the movement of a subject.
- ◆ WINDOW TONE [0~4] : Set out area tone of motion zone.
- ◆ WINDOW ZONE [0~3] : Select the window area.
- ◆ WINDOW USE [ON, OFF]
- ◆ DET H-POS [0~60] : Define the horizontal start position of the monitoring area.
- ◆ DET V-POS [0~34] : Define the vertical start position of the monitoring area.
- ◆ DET H-SIZE [0~60] : Define the horizontal size of the monitoring area.
- ◆ DET V-SIZE [0~34] : Define the vertical size of the monitoring area.
- ◆ ALARM [ON, OFF] : In motion situation, you can select the detail of option setting.

SYSTEM

This can be used when you want to select the additional function control.

1. When the SETUP menu is displayed, select SYSTEM using the Up and Down button.
2. Select one of the mode using the Up and Down button.

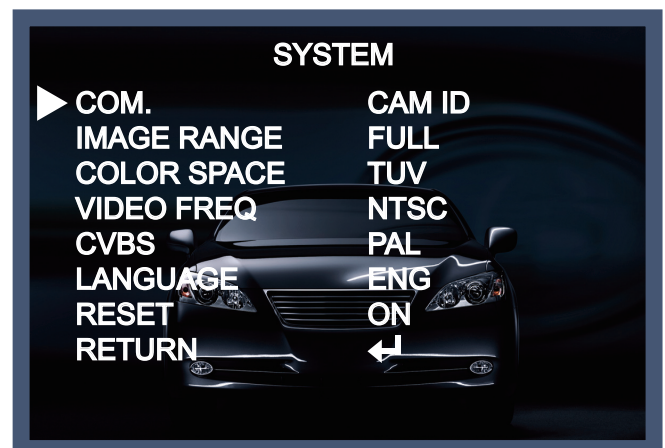
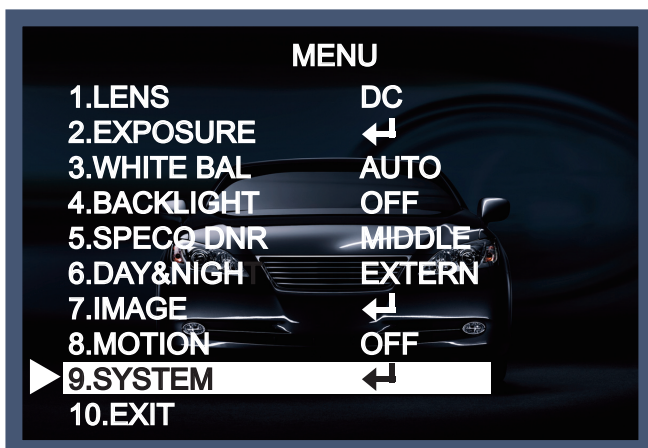

- ◆ COM. : This menu is used for RS-485 communication. Users are able to select 'CAM ID(0~255)' and 'BAUDRATE(2400/4800/9600/57600/115200).
- ◆ IMAGE RANGE [FULL/COMP/USER] : Adjust the rate of YC signal to 100%(FULL), 75%(COMP) or 100%~75%(USER).
- ◆ COLOR SPACE [YUV/SD-CBCR/HD-CBCR] : Select different color settings for a warmer or a colder image.
- ◆ VIDEO FREQ: TV System is Switchable 'NTSC' or 'PAL'
- ◆ CVBS [PAL/NTSC] : Select the video format that matches the present TV system.
- ◆ LANGUAGE : ENG, CHN, CHN(S), JPN, KOR
- ◆ RESET [ON] : Return to factory default setting value.

Exit

Press the Set button in the exit menu to save the current settings and exit the Set Up menu.

• Trouble Shooting

PROBLEM	POSSIBLE CAUSE
Nothing appears on the screen.	☞ Check the power cable, power supply output and video connection between the camera and monitor.
The image on the screen is dim.	☞ Are the camera lens or the lens glass dirty? Clean the lens / glass with a soft clean cloth. ☞ Adjust the monitor controls, as required. ☞ If the camera is facing a very strong light, change the camera position. ☞ Adjust the lens focus.
The image on the screen is dark.	☞ Adjust the contrast control of the monitor. ☞ If there is an intermediate device, correctly set the 75Ω/Hi-z.
The camera is not working properly and the surface of the camera is hot.	☞ Check the camera is correctly connected to an appropriate regulated power source.
Motion Detection is not activated.	☞ Has MOTION DET been set to ON in the menu? ☞ Has MD AREA been properly defined?
The color of the picture is not correct.	☞ Check the settings in WHITE BALANCE menu.
The image on the screen flickers.	☞ Make sure that the camera isn't facing direct sunlight or fluorescent lighting. If necessary, change the camera position.
The INTENSIFY does not work.	☞ Check that the AGC setting in the EXPOSURE menu is not set to OFF. ☞ Check the EXPOSURE menu and make sure SHUTTER is set to----- .



LIMITED WARRANTY - VIDEO PRODUCTS

THIS WARRANTY IS VALID ONLY ON PRODUCTS PURCHASED AND USED IN THE UNITED STATES OF AMERICA AND CANADA. THIS WARRANTY APPLIES ONLY TO THE ORIGINAL USER.

SUBJECT TO CONDITIONS AND EXCLUSIONS FOUND BELOW, THIS PRODUCT IS WARRANTED AGAINST MANUFACTURING DEFECTS IN MATERIAL AND WORKMANSHIP FOR THE FOLLOWING PERIOD FOR PARTS AND LABOR:

SPECO TECHNOLOGIES CAMERAS	5 YEARS	DVRs	3 YEARS
SPECO TECHNOLOGIES IP CAMERAS.....	2 YEARS	NVRs	3 YEARS
SPECO PTZ AND VL CAMERAS.....	1 YEAR	BALANCE OF	
SPECO TECHNOLOGIES MONITORS.....	1 YEAR	SPECO TECHNOLOGIES LINE	1 YEAR
IR LEADS	90 DAYS		

SPECO TECHNOLOGIES WILL REPAIR OR REPLACE (AT OUR DISCRETION) ANY PARTS FOUND TO BE DEFECTIVE FOR THE WARRANTY PERIOD SPECIFIED. WE WILL PROVIDE A REPLACEMENT FOR ANY DEFECTIVE PART.

CONDITIONS

- 1. YOU MUST OBTAIN A RETURN AUTHORIZATION (RA) NUMBER FOR ANY MERCHANDISE BEING RETURNED TO SPECO TECHNOLOGIES, WHETHER FOR RETURN/EXCHANGE OR REPAIR, WHETHER IN OR OUT OF WARRANTY.**
2. THIS WARRANTY WILL BE HONORED ONLY UPON PRESENTATION OF THE ORIGINAL DATED BILL OF SALE OR SALES SLIP.
3. TRANSPORTATION OF THE PRODUCT TO OUR SERVICE DEPARTMENT IS THE RESPONSIBILITY OF THE USER. REPAIRED OR REPLACED PRODUCT WILL BE RETURNED PREPAID DURING THE WARRANTY PERIOD.
4. SPECO TECHNOLOGIES DOES NOT AUTHORIZE ANY INTERNET OR MAIL ORDER PRODUCT SALES. IF A SPECO TECHNOLOGIES PRODUCT IS PURCHASED FROM AN UNAUTHORIZED DISTRIBUTOR OR OTHER SOURCE, INCLUDING RETAILERS, MAIL ORDER SELLERS AND ONLINE SELLERS, IT WILL NOT BE HONORED OR SERVICED UNDER THE EXISTING SPECO TECHNOLOGIES WARRANTY POLICY. ANY SPECO TECHNOLOGIES PRODUCT PURCHASED FROM THESE ONLINE MERCHANTS WILL VOID THE APPLICABLE WARRANTY AND IS INELIGIBLE FOR TECHNICAL SUPPORT. IF YOU HAVE QUESTIONS ABOUT A RESELLER, PLEASE CONTACT SPECO TECHNOLOGIES AT 1-800-645-5516 FOR A LIST OF UNAUTHORIZED DEALERS, VISIT: www.specotech.com/unauthorized.

EXCLUSIONS

1. THIS WARRANTY SHALL NOT COVER ADJUSTMENT OF CUSTOMER OPERATED CONTROLS AS EXPLAINED IN THE APPROPRIATE Model 's INSTRUCTION MANUAL OR PRODUCTS WHICH HAVE BEEN ALTERED, ABUSED, OR HAVE MISSING OR ALTERED SERIAL NUMBERS.
2. THIS WARRANTY SHALL NOT APPLY TO UNCRATING, SETUP, INSTALLATION, OR THE REMOVAL AND REINSTALLATION OF PRODUCTS AFTER REPAIR.
3. THIS WARRANTY SHALL NOT APPLY TO REPAIRS OR REPLACEMENTS NECESSITATED BY ANY CAUSE BEYOND THE RESULT OF MANUFACTURE INCLUDING, BUT NOT LIMITED TO, ANY MALFUNCTION, DEFECTS OR FAILURE CAUSED BY OR RESULTING FROM UNAUTHORIZED SERVICE OR PARTS, IMPROPER MAINTENANCE, MODIFICATION OR REPAIR BY THE USER, ABUSE, MISUSE, NEGLIGENCE, ACCIDENT, FIRE, FLOOD, OR OTHER ACTS OF NATURE, INCORRECT LINE VOLTAGE, DAMAGE OR IMAGE BURNS TO TELEVISION PICTURE TUBES CAUSED BY OR ATTRIBUTABLE TO THE USE OF ANY ACCESSORY, ELECTRONICS GAME OR DEVICE, OR DAMAGE CAUSED TO IMAGE PICKUP DEVICES BY EXCESSIVE LIGHT.

THE FOREGOING IS IN LIEU OF ALL OTHER EXPRESSED WARRANTIES AND WE DO NOT AUTHORIZE ANY PARTY TO ASSUME FOR US ANY OTHER OBLIGATION OR LIABILITY. IN NO EVENT SHALL WE BE LIABLE FOR INCIDENTAL OR CONSEQUENTIAL DAMAGES ARISING FROM THE USE OF THIS PRODUCT, OR FOR ANY DELAY IN THE USE OF THIS PRODUCT DUE TO CAUSES BEYOND OUR CONTROL. SOME STATES DO NOT ALLOW LIMITATIONS OF HOW LONG AN IMPLIED WARRANTY LASTS AND/OR DO NOT ALLOW THE EXCLUSION OR LIMITATION OF CONSEQUENTIAL DAMAGES. THE ABOVE LIMITATIONS ON IMPLIED WARRANTY AND CONSEQUENTIAL DAMAGES MAY NOT APPLY TO YOU.

THIS WARRANTY GIVES YOU SPECIFIC LEGAL RIGHTS. YOU MAY HAVE OTHER RIGHTS WHICH VARY FROM STATE TO STATE.

NOTE: FOR YOUR PROTECTION IN THE EVENT OF THEFT OR LOSS OF THIS PRODUCT, PLEASE FILL IN THE INFORMATION REQUESTED BELOW AND RETAIN WITH YOUR SALES RECEIPT.

MODEL NO.: _____ SERIAL NO.: _____
(LOCATED ON BACK OR BOTTOM OF UNIT)

DATE OF PURCHASE: _____

WHERE PURCHASED: _____ PURCHASE PRICE: _____

Speco Technologies 200 New Highway Amityville, NY 11701 www.specotech.com	FOR MORE INFORMATION REGARDING SERVICE OR RETURN, CALL US TOLL FREE: 1-800-645-5516 IN METRO NY: 631-957-8700
---	---

ALWAYS USE DISCRETION WHEN INSTALLING VIDEO AND/OR AUDIO SURVEILLANCE EQUIPMENT ESPECIALLY WHEN THERE IS AN EXPECTATION OF PRIVACY. INQUIRE REGARDING FEDERAL, STATE AND/OR LOCAL REGULATIONS APPLICABLE TO THE LAWFUL INSTALLATION OF VIDEO AND/OR AUDIO RECORDING OR SURVEILLANCE EQUIPMENT. PARTY CONSENT MAY BE REQUIRED.

▶MEMO

▶MEMO

▶MEMO



**200 New Highway
Amityville, NY 11701
631-957-8700
1 800 645 5516
www.specotech.com**