

All New EZN Series IR Bullet Network Camera

Auto Focus, WDR & IR

User's Manual



 **EverFocus**

Copyright © EverFocus Electronics Corp,
Release Date: November, 2016



Copyright © 1995-2016 EverFocus Electronics Corp.

Disclaimer

All the images including product pictures or screen shots in this document are for example only. The images may vary depending on the product and software version. Information contained in this document is subject to change without notice.

Copyright

All rights reserved. No part of the contents of this manual may be reproduced or transmitted in any form or by any means without written permission of the EverFocus Electronics Corporation.

EverFocus

12F-1, No.79, Sec. 1, Shin-Tai Wu Road,

Hsi-Chih, New Taipei City, Taiwan

TEL: +886 2 2698 2334

FAX: +886 2 2698 3943

www.everfocus.com.tw

November, 2016

About this document

All the safety and operating instructions should be read and followed before the unit is operated. This manual should be retained for future reference. The information in this manual was current when published. The manufacturer reserves the right to revise and improve its products. All specifications are therefore subject to change without notice.

Regulatory Notices

FCC Notice "Declaration of Conformity Information"

This equipment has been tested and found to comply with the limits for a Class A digital device, pursuant to part 15 of the FCC Rules. These limits are designed to provide reasonable protection against harmful interference in a residential installation. This equipment generates, uses and can radiate radio frequency energy and, if not installed and used in accordance with the instructions, may cause harmful interference to radio communications. However, there is no guarantee that interference will not occur in a particular installation. If this equipment does cause harmful interference to radio or television reception, which can be determined by turning the equipment off and on, the user is encouraged to try to correct the interference by one or more of the following measures:

- Reorient or relocate the receiving antenna.
- Increase the separation between the equipment and receiver.
- Connect the equipment into an outlet on a circuit different from that to which the receiver is connected.
- Consult the dealer or an experienced radio/TV technician for help.

Warning: Changes or modifications made to this equipment, not expressly approved by EverFocus or parties authorized by EverFocus could void the user's authority to operate the equipment.

This device complies with part 15 of the FCC Rules. Operation is subject to the following two conditions:

- (1) This device may not cause harmful interference, and
- (2) This device must accept any interference received, including interference that may cause undesired operation.

EverFocus Electronics Corp.

12F-1, No. 79, Sec. 1, Shin-Tai Wu Rd.,

Hsi-Chi, New Taipei City, Taiwan

EZN Series cameras comply with CE and FCC.

Precautions

1. Do not install the camera near electric or magnetic fields.

Install the camera away from TV/radio transmitters, magnets, electric motors, transformers and audio speakers since the electromagnetic fields generated from these devices may distort the video image or otherwise interfere with camera operation.

2. Never disassemble the camera beyond the recommendations in this manual nor introduce materials other than those recommended herein.

Improper disassembly or introduction of corrosive materials may result in equipment failure or other damage.

3. Try to avoid facing the camera toward the sun.

In some circumstances, direct sunlight may cause permanent damage to the sensor and/or internal circuits, as well as creating unbalanced illumination beyond the capability of the camera to compensate.

4. Keep the power cord away from water and other liquids and never touch the power cord with wet hands.

Touching a wet power cord with your hands or touching the power cord with wet hands may result in electric shock.

5. Never install the camera in areas exposed to oil, gas or solvents.

Oil, gas or solvents may result in equipment failure, electric shock or, in extreme cases, fire.

6. Cleaning

For cameras with interchangeable lenses, do not touch the surface of the sensor directly with the hands. Use lens tissue or a cotton tipped applicator and ethanol to clean the sensor and the camera lens. Use a damp soft cloth to remove any dirt from the camera body. Please do not use complex solvents, corrosive or abrasive agents for cleaning of any part of the camera.

7. Do not operate the camera beyond the specified temperature, humidity or power source ratings.

Use the camera at temperatures within $-40^{\circ}\text{C} \sim 55^{\circ}\text{C}$ / $-40^{\circ}\text{F} \sim 131^{\circ}\text{F}$ (12VDC) or $-20^{\circ}\text{C} \sim 55^{\circ}\text{C}$ / $-4^{\circ}\text{F} \sim 131^{\circ}\text{F}$ (PoE), and humidity between 20% and 80%; this device is not rated as submersible. The input power source is 12 VDC / PoE. Be sure to connect the proper + / - polarity and voltage, as incorrect polarity or too high a voltage will likely cause the camera to fail, and such damage is not covered by the warranty. The use of properly fused or Class 3 power limited type supplies is highly recommended.

8. Mounting

Use care in selecting a solid mounting surface which will support the weight of the camera plus any wind, snow, ice or other loading, and securely attach the camera to the mounting surface using screws and anchors which will properly support the camera. If necessary (e.g. when mounting to drop ceilings) use a safety wire to provide additional support for the camera.

CONTENTS

1. Introduction	1
2. Physical Description	2
2.1 Dimensions	2
3. Features	3
4. Installation	4
4.1 Packing List	4
4.2 Optional Accessory	4
4.3 Cables	5
4.4 Basic Installation	6
4.4.1 Mounting and Wiring	6
4.4.2 Inserting a Micro SD Card	9
5. Accessing the Camera	10
5.1 Checking the Dynamic IP Address	10
5.2 Settings for Microsoft Internet Explorer	13
5.3 Connecting the Camera to the Network	15
5.4 Live View Window	17
6 Playback	22
6.1 Remote Playback Using Playback Page	22
6.2 Setting up the Playback Function	24
6.2.1 Inserting / Removing the micro SD Card	24
6.2.2 Testing the Playback Function	25
6.3 Playing Back Using ARV Viewer	27
7 Settings	29
7.1 System Settings	30
7.1.1 Network	30
7.1.2 Date / Time	36
7.1.3 Storage	37
7.1.4 Display and Overlay	39
7.1.5 System Maintenance	41
7.1.6 System Information	44
7.1.7 User	45
7.1.8 Black / White List	47
7.2 Camera Settings	48

7.2.1	Streaming and Audio	48
7.2.2	Profile	51
7.2.3	Camera	53
7.2.4	Schedule	57
7.2.5	Image	58
7.2.6	Serial Communication	60
7.3	Event Settings	61
7.3.1	Event Wizard	61
7.3.2	Event	62
7.3.3	Notification	66
7.4	Link to Smart Phone App	69
8.	Upgrading Firmware Using IP Utility	70
9.	Specifications	72
10.	Troubleshooting	74
Appendix	77
A.	Tested Card Brands.....	77
B.	Enabling the Multicast Function	78

1. Introduction

The new EZN series IP bullet camera comes with two models: 1.3 MP and 2 MP, providing up to 30 fps at 1280 x 1024 / 1920 x 1080 viewing resolution. Equipped with an auto focus lens, the series can provide the desired field of view with superior video quality in precision focus. Users can remotely adjust camera focus through the Web interface of the camera.

The new EZN series supports dual streams from H.264 and MJPEG. Equipped with a P-Iris, the cameras are capable of controlling the best iris position automatically and precisely in varying lighting conditions, expanding the focus area of the images and meanwhile improve the image sharpness. Featured with a weather-resistant (IP66) housing plus 44 IR LEDs for enabling the night visibility of up to 40m / 131ft., the cameras meet a wide variety of needs for outdoor surveillance.

The new EZN series features the Wide Dynamic Range (WDR) function, which can provide clear images even under back light circumstances where intensity of illumination can vary excessively. The DNR (Digital Noise Reduction) function is designed for reducing the noises in the images, allowing the camera to better distinguish between real motion and image noise, and thus results in a possibility to store more video evidence on the connected storage devices.

A built-in micro SDHC card slot and Power over Ethernet (IEEE802.3af Class 3) features are also provided. You can power the camera over the network or by connecting the camera to a 12VDC power supply. Since the EZN series conforms to ONVIF for compatibility with other network video devices, it interoperates with a wide variety of hardware and software systems. You can also use EverFocus Mobile Applications to remotely view the live views of the cameras through your handheld devices; or use EverFocus CMS to remotely manage multiple IP devices connected on the network.

The EZN Series Models

Model Name	Megapixel	Auto Focus	Smart IR	P-IRIS	DNR	WDR
EZN3160	1.3MP	Yes	Yes	Yes	Yes	Yes
EZN3260	2MP	Yes	Yes	Yes	Yes	Yes

System Requirement

Before installing, please check that your computer meets these system requirements.

- Operating System: Microsoft Windows XP / Vista (32-bit) / 7 (32-bit)
- Microsoft Internet Explorer 7 or above

Note: For using the Internet Explorer, some settings are required. Please refer to *5.2 Settings for Microsoft Internet Explorer*.

2. Physical Description



No.	Name	Description
1	Micro SD / SDHC Slot	For inserting a micro SD / SDHC card.
2	Reset Button	Resets all configurations to the factory default settings. Press and hold the Reset Button for 5 seconds.
3	IR LEDs	44 IR LEDs for infrared illumination in night vision applications.
4	Lens	3.3 – 10 mm, auto focus, varifocal, F1.3 – 360C.
5	Light Sensor	Detects lights.
6	Sunshield	Protect the camera from the direct rays of the sun.

2.1 Dimensions

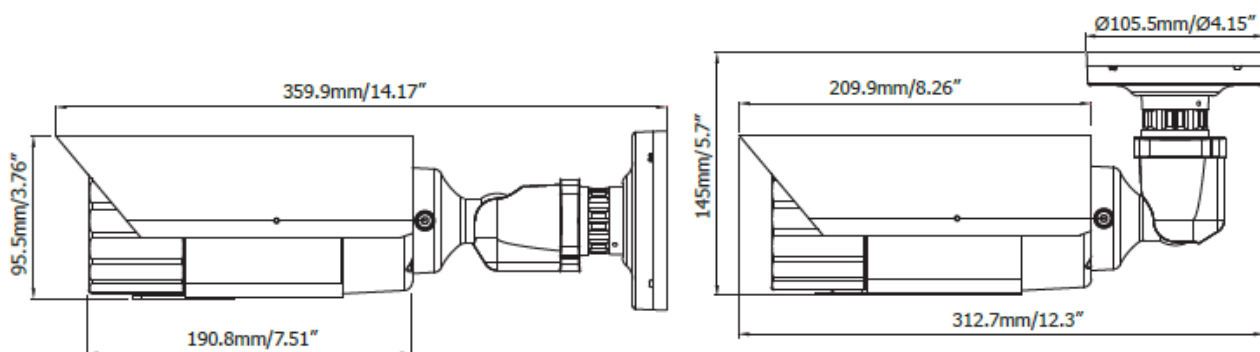

3. Features

- 1/2.8" HD color CMOS image sensor delivers high resolution, and supports both H.264 and M-JPEG in full frame rate
- One push auto focus for remote image adjustment
- P-IRIS lens with a stepping motor for exact positioning to improve the IRIS performance
- Smart IR function eliminates overexposure problems
- High Performance Noise Filter improves image quality
- Wide Dynamic Range
- Provides true day/night functionality with automatic IR filter operation
- Multi profiles settings for allows choice of image quality to fit the environment
- Two Way Audio transport (line level input/output)
- Dual power capability PoE or 12VDC for flexible installation
- Local alarm inputs and outputs
- Extended IR range of up to 40M/131ft. with 44 LEDs
- Split glass to prevent internal IR reflections
- E-Z lock ring at the base is designed with easy to grip tabs for firmly clamp the camera in place, plus a set screw for added security
- IP68 water proof and IK10 vandal resistance(for metal casing)
- Built-in SDHC slot for a micro SDHC card enabling local storage, up to 32GB, support manual/event/schedule recording
- Supports live monitoring of video from mobile devices via MobileFocus / MobileFocus Plus apps (iOS and Android)
- ONVIF compliant

4. Installation

4.1 Packing List

Please check that there is no missing item in the package before installing.

- EZN Series Camera x 1
- Cable Gland Kit x 1 (connect to the LAN/PoE cable for waterproofing)
- Quick Mounting Ring x 1
- MAC Address Sticker x 2
- Mounting Kit x 1
 - Long Screw x 4 (for attaching the Quick Mounting Ring to the mounting surface)
 - Short Screw x 4 (for connecting the camera base to the Quick Mount Ring)
 - Screw Anchor x 4 (in conjunction with Long Screw)
 - Hexagon Wrench x 1 (for adjusting the camera position)
 - Thinner Hexagon Wrench x 1 (for removing the Sunshield)
 - Desiccant Bag x 1
- Power Pigtail Cable x 1
- Plug x 1 (inserting to the Quick Mounting Ring for through-the-wall installation)
- Software CD x 1
- Quick Installation Guide x 1

Note:

1. Equipment configurations and supplied accessories vary by country. Please consult your local EverFocus office or agents for more information. Please also keep the shipping carton for possible future use.
2. Contact the shipper if any items appear to have been damaged in the shipping process.

4.2 Optional Accessory

You can use the optional accessory to expand the capabilities and versatility of the camera. Please contact your dealer for more information.

- IP Sidekick - ESK1000



Using IP Sidekick – ESK1000 for installation, you do not need to pre-configure the IP address or to use an additional monitor to check and adjust all the IP cameras. The IP Sidekick can assign an IP address to the camera through its Wi-Fi network, and then you can connect and check the camera live view using our mobile app. For details about IP Sidekick, please refer to the *IP Sidekick – ESK1000 User’s Manual*.

4.3 Cables

The Cables provide connections for Network, GND, CVBS output, power, audio input / output and alarm input / output. Note that the audio-in / out cable features a line 3.5mm jack (TRS). Be sure to prepare microphones / speakers with TRS connector (see TRS Connector image below). Also, microphones / speakers with a (built-in) amplifier and external power supply are required.

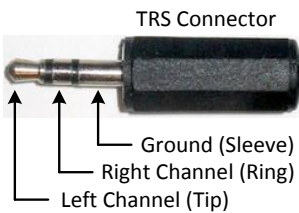
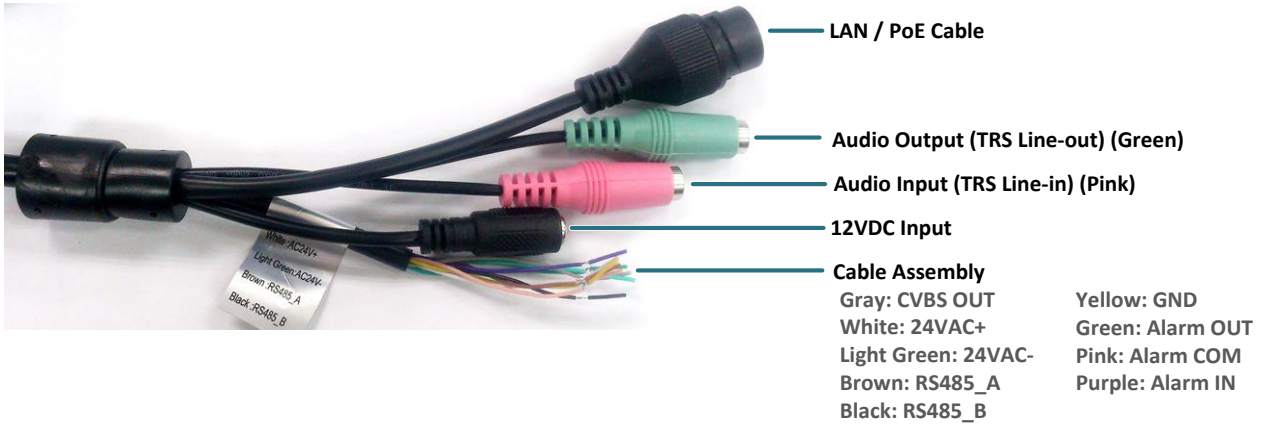

To activate the Audio function, the **Enable Audio** must be checked. See *7.2.1 Streaming and Audio*.

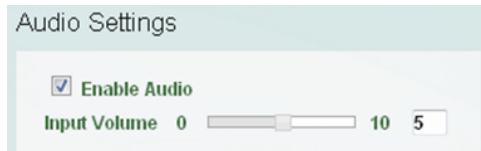

4.4 Basic Installation

4.4.1 Mounting and Wiring

Follow the steps below for mounting and wiring the camera.

1. Before screwing the camera to the wall, drill four holes on the wall according to the hole-positions on the supplied **Quick-Mounting Ring**. If you wish to run the wires into the wall, drill another hole in the middle of the circular area within the **Quick-Mounting Ring**.

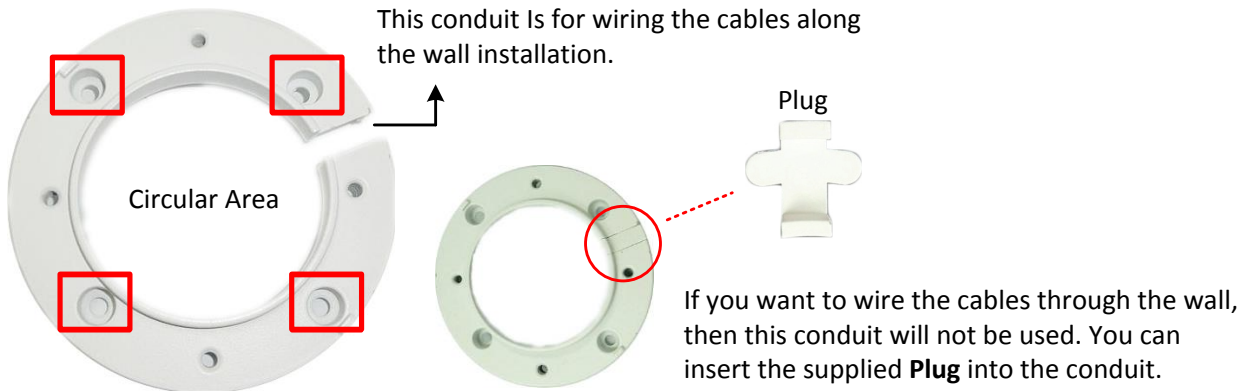

2. Push the four supplied **Anchors** into the four holes on the wall. Place the **Quick-Mounting Ring** against the anchoring surface so that the holes line up. Screw the **Quick-Mounting Ring** to the wall using the supplied **Long Screws**.

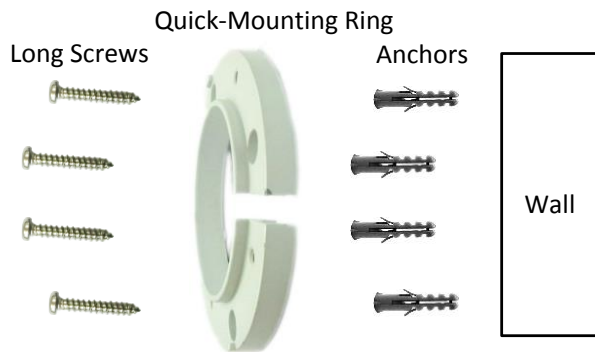

3. Screw the camera base to the **Quick-Mounting Ring** using the supplied four **Short Screws**.

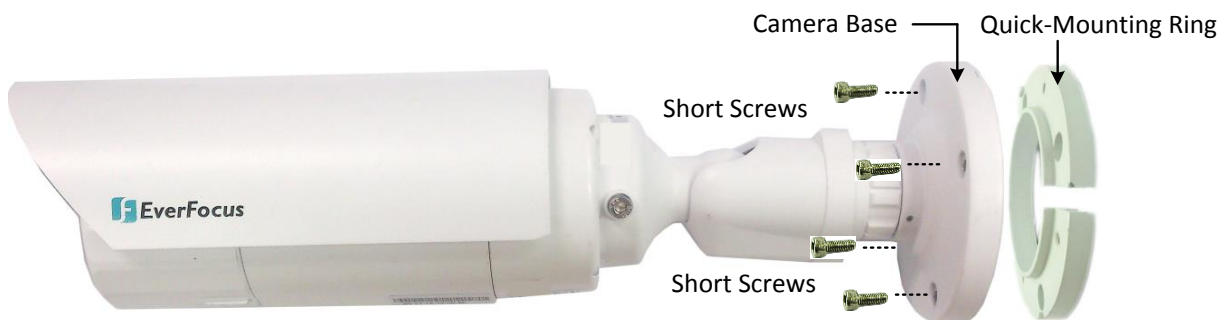

You can wire the cables from the side of the camera or through the wall.



Wire the cables from the side of the camera



Wire the cables through the wall

4. Connect the network, power and other cables of the camera to the related devices.
 - If you want to use the **Cable Gland** to connect the network cable for waterproofing:
 - a. Insert the supplied **Stopper** to the **Cable Gland**.

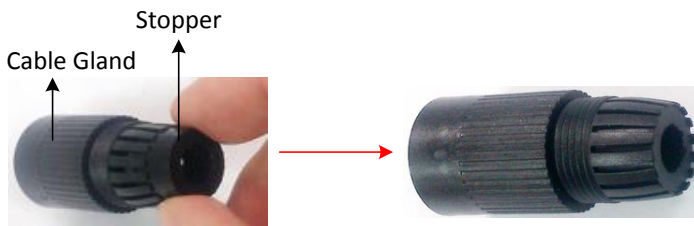

- b. Insert a RJ-45 network cable (without the RJ-45 connector on the one end) through the **Screw Cap** and **Cable Gland**.



- c. Crimp the RJ-45 connector onto the network cable. Note that the wires should be placed into the RJ-45 connector based on the following order (from left to right).

- Orange with white stripe
- Orange
- Green with white stripe
- Blue
- Blue with white stripe
- Green
- Brown with white stripe
- Brown



- d. Connect the RJ-45 network cable to the LAN / PoE Cable. Tightly screw the **Cable Gland** and **Screw Cap**.



5. Optionally insert a micro SD / SDHC card into the card slot. Please refer to 4.2.2 *Inserting a micro SD Card*.

6. Access the camera live view. See 5. *Accessing the Camera*. Or connect a handheld test monitor to the CVBS wire on the Cable Assembly for adjusting viewing angles.
7. To adjust the camera angles:

Pan Adjustment: Unscrew the Set Screw using the supplied Thinner Hexagon Wrench. Twist the Camera Body forcefully until it unscrews from the Camera Base. Rotate the camera by 360° to the desired position and screw the E-Z Lock Ring until it locks against the Camera Base. Screw back the Set Screw.



Tilt Adjustment: Loosen the Tilt Screw using the provided Hexagon Wrench and adjust the tilt angle by 90°.

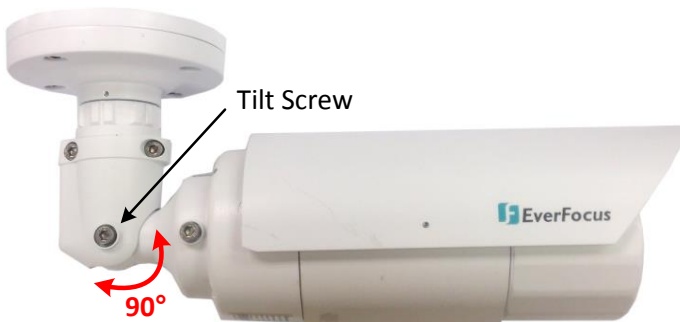

Rotational Adjustment: Loosen the Rotate Screws on both side of the camera body using the providing Hexagon Wrench and rotate the camera by 360° (180° to the left / 180° to the right).

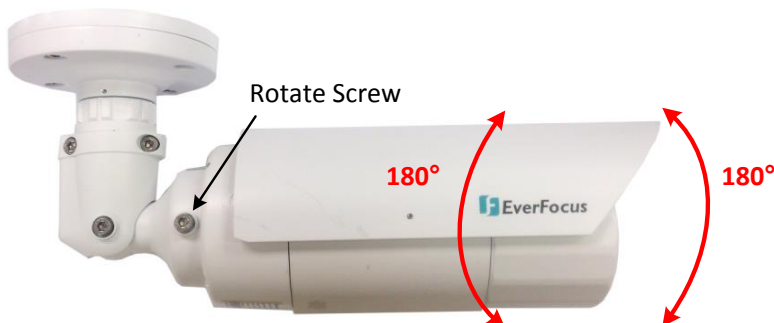

8. To adjust zoom and focus, please use **Lens Control** buttons on the Live View window. Please refer to 5.4 *Live View Window* in the *User's Manual*.

Note: Before start operating the IP camera, please make sure the camera date and time are correct. To configure the camera date/time, go to System > Date/Time setting page on Web UI.

4.4.2 Inserting a Micro SD Card

You can optionally insert a micro SD card to the card slot on the camera module for recording videos.

1. Remove the **Sunshield** from the camera. Loosen the set screw on the **Sunshield** using the provided **Thinner Hexagon Wrench**. Slide the Sunshield out from the rail on the camera body.



2. Rotate and then remove the camera cover, and insert a micro SD card into the card slot.

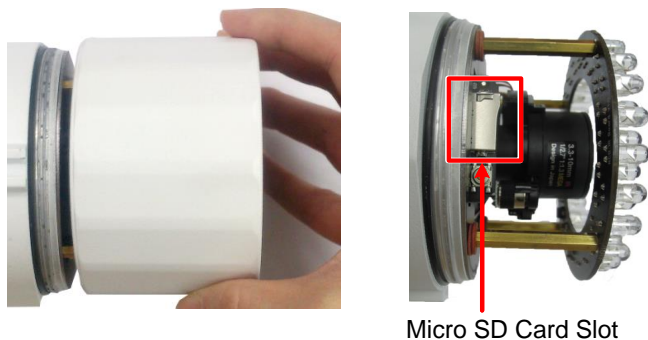

Note: After opening the camera cover for inserting the micro SD card, you have to close the cover immediately in case of reducing the absorption capacity of the desiccant bag inside the camera.

3. Stick the supplied **Desiccant Bag** inside the camera.



4. Firmly close the camera cover for waterproofing and then slide the **Sunshield** back to the camera body.

Note: When properly installed, the rear-side of the **Sunshield** should be even with the rear-side of the camera body. Extending the **Sunshield** in order to shade the lens will compromise the image quality.

5. Accessing the Camera

This section explains how to access the Web interface of the camera for configuration.

5.1 Checking the Dynamic IP Address

You can look up the IP address and access the Web interface of the camera using the **IP Utility (IPU)** software included in the software CD or from the Website of EverFocus (click [here](#) to download). Please connect the IP camera in the same LAN of your computer.

1. Save **IP Utility Setup AutoRun.exe**  in your computer. Double click the **.exe** file and follow the on-screen instructions. Check **Run IPUtility.exe** and click the **Finish** button, the IP Utility will be launched to search the IP devices connected in the same LAN automatically.

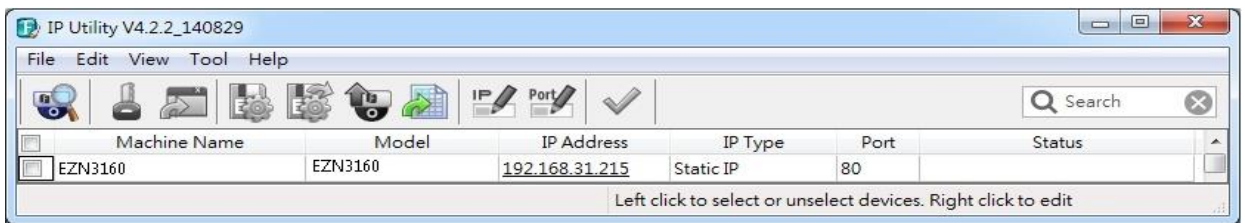
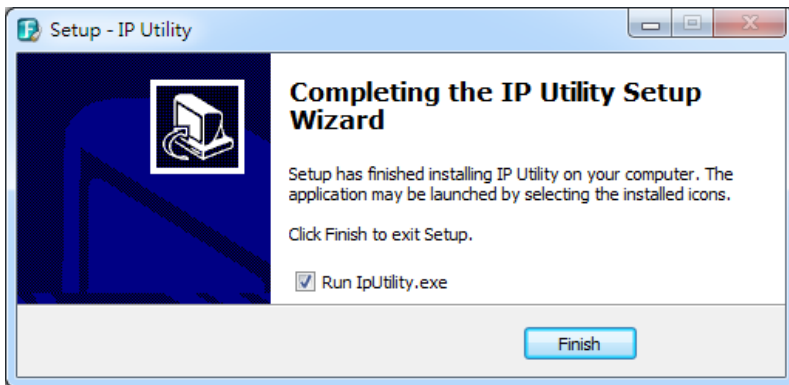

2. To access to the Live View window, double click the IP address of the desired device, the login window pops up. Type the user ID and password to log in. By default, the user ID is **user1** and the password is **11111111**.

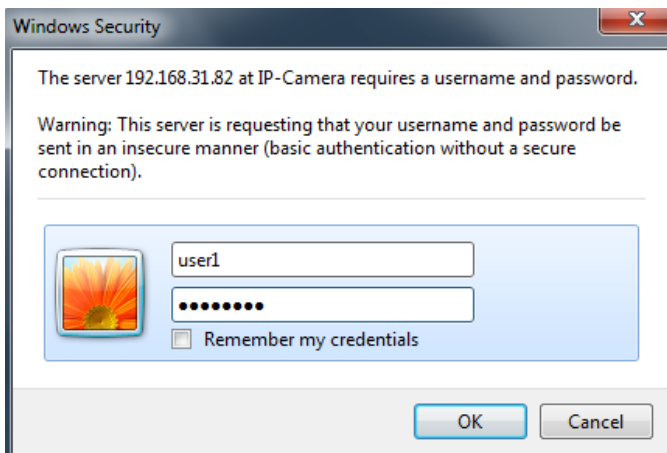

- Click **OK**, the Live View window appears.

Note:

- You might be required to download **ActiveX** for viewing the camera feed. If asked, click **Yes**.
- To enable Remote Live View, Firmware Upgrade and ActiveX Prompt on Internet Explorer, some settings have to be complete. Please refer to *5.2 Settings for Microsoft Internet Explorer* in the *User's Manual*.

- To optionally configure the Machine Name, IP Address, IP Type or Port Number using the IPU:
 - Log in the camera by checking the desired model and then click the **Log in**  icon. The Log in dialog box appears.



- Type the Username and Password. Click the **OK** button, the **Login** status displays.

Machine Name	Model	IP Address	IP Type	Port	Status
<input checked="" type="checkbox"/> EZN3160	EZN3160	192.168.31.215	Static IP	80	Login

Note:

- The default user ID is **user1** and the default password is **1111111**.
- If you select more than one camera that has the same user ID / password, you will be able to log in several cameras at once.

- Right click the column to configure the settings. Click the **Apply Changes**  button to apply and save the settings.

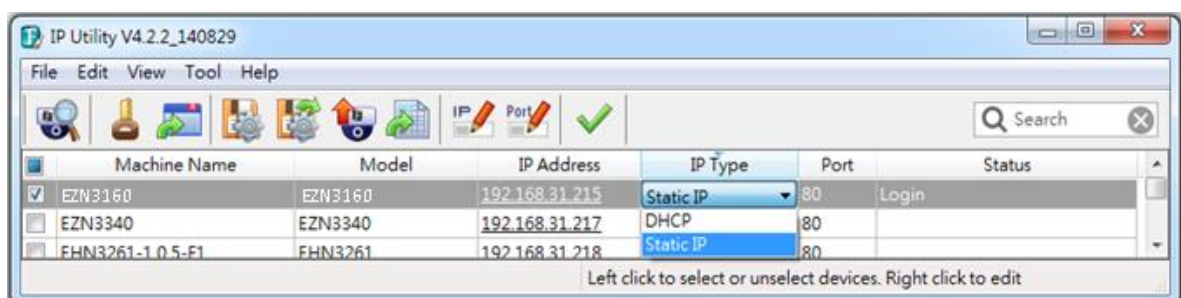

Note:

- Most networks uses DHCP to assign IP address, if you are unsure of your network settings, please consult your network administrators for configuration details.
- If you want to set up PPPoE, please refer to *7.1.1 Network*.

To set up a static IP:

By default, EverFocus' IP cameras are set up with DHCP. To change the IP setting to static IP, select **Static** from **IP Type** drop-down list and set up the desired IP Address, for example, 172.17.0.145. Please also set up the Subnet Mask and Gateway. Click the **Apply Changes** button to apply and save the settings.

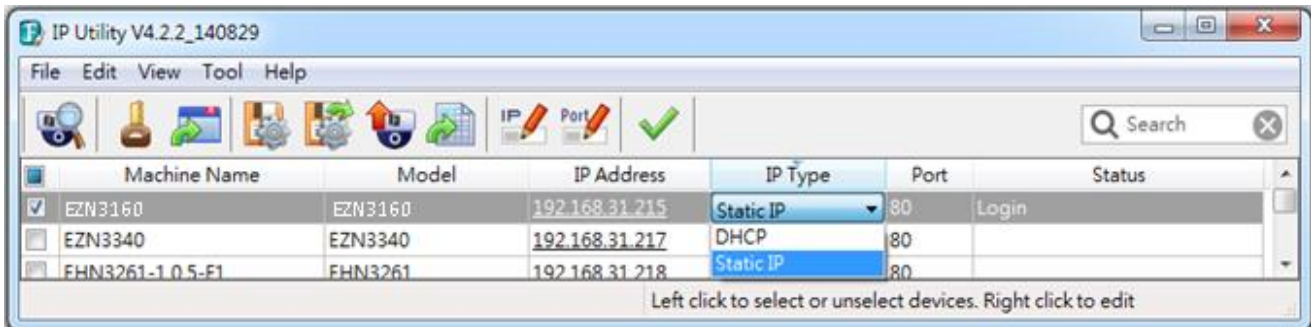

To show the Subnet Mask and Gateway items on the title bar, right click the title bar to display the **Customize Columns** window, select **Subnet Mask** and **Gateway** and then click **OK**.

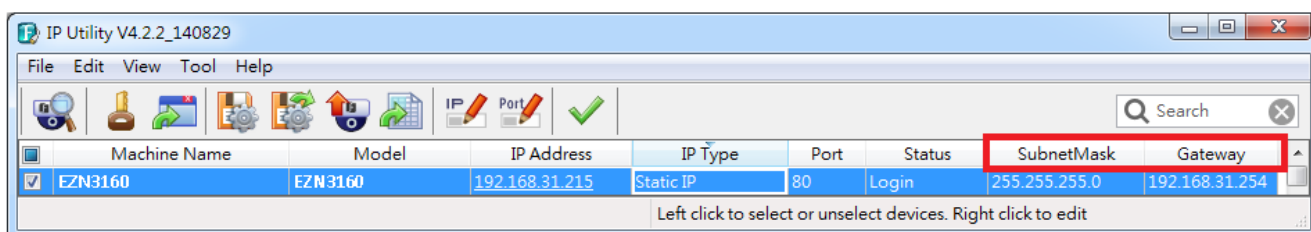
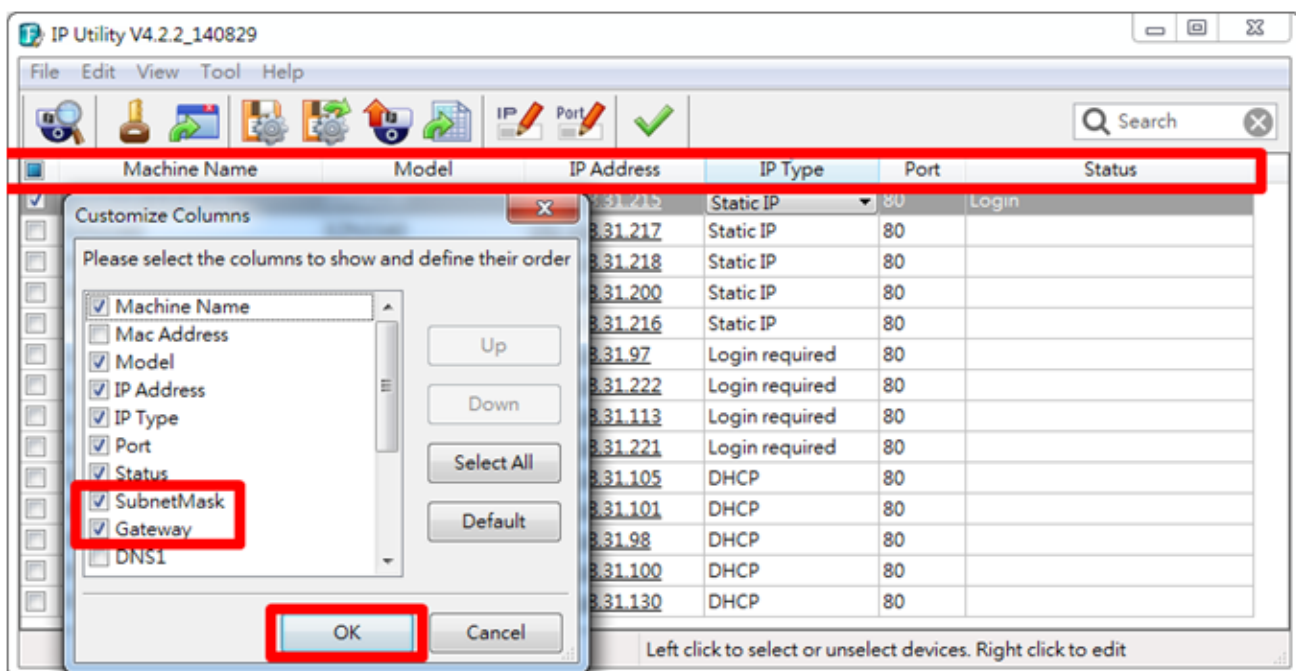

5.2 Settings for Microsoft Internet Explorer

To enable Remote Live View, Firmware Upgrade and ActiveX Prompt on Internet Explorer, some settings have to be complete. Please follow the steps below:

1. On the computer, click Start > Control Panel > System and Security > Action Center (click Change User Account Control Settings), the **User Account Control Settings** window appears. Adjust the slide bar to **Never Notify** and then click **OK**. Restart your computer if requested.

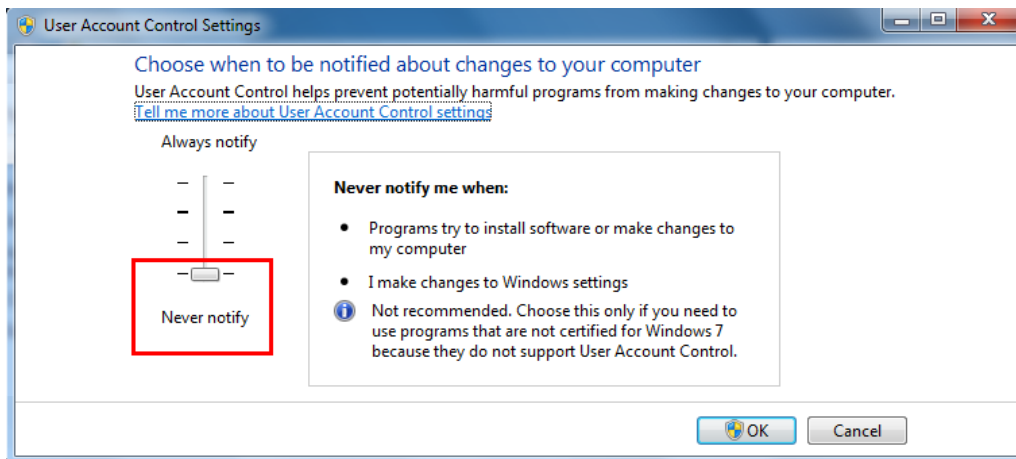

2. Open the Internet Explore, click Tools > Internet Options > Security Tab > Custom Level, the **Security Settings** windows appears.

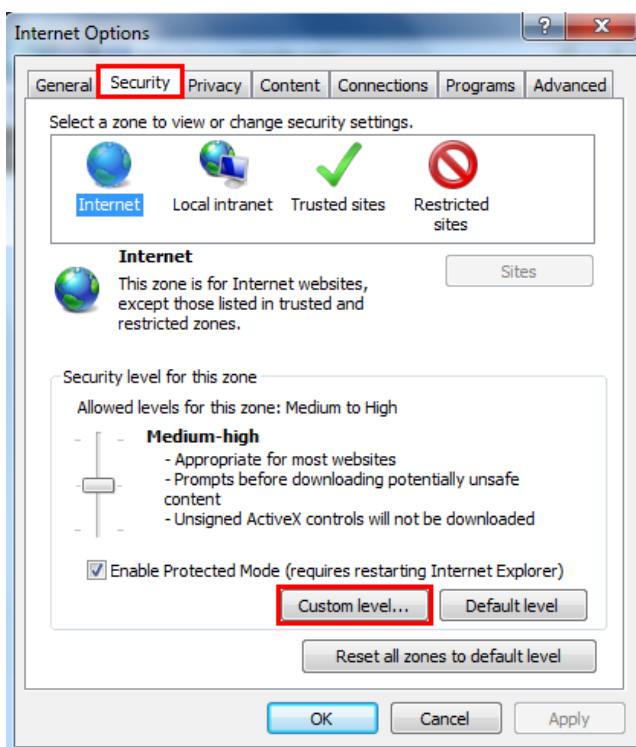

3. In the **Download unsigned ActiveX controls** field, select **Prompt**. In the **Include local directory path when uploading files to a server** field, select **Enable**. Click **OK**.

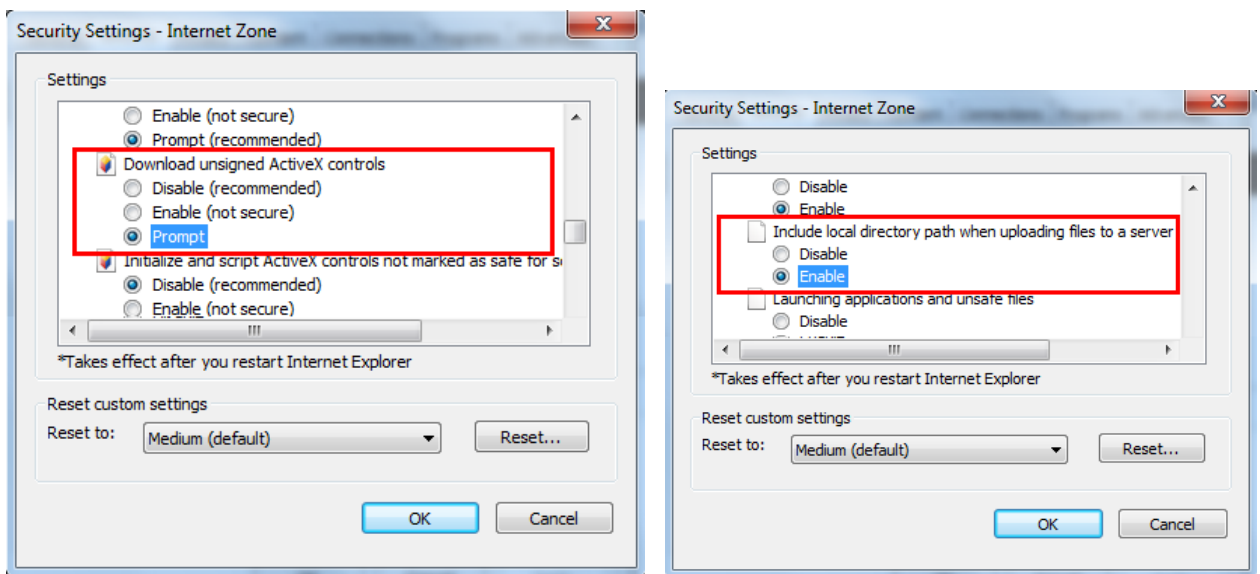

4. In the Internet Options window, click the **Advanced** tab and then disable **Enable memory protection to help mitigate online attacks** to help mitigate online attacks. Click **OK**.

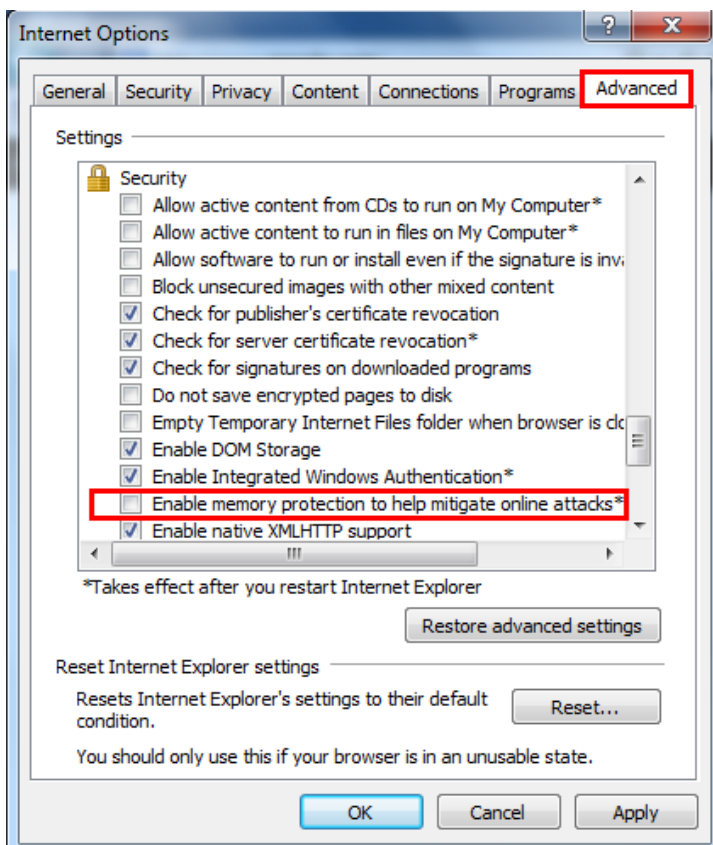

5.3 Connecting the Camera to the Network

There are three methods to connect the IP camera to the network: **Router or LAN Connection**, **Direct High-Speed Connection** and **One-to-One Connection**.

Router or LAN connection

This is the most common connection in which the IP camera is connected to a router and allows multiple users on and off site to see the IP camera on a LAN/WAN (Internet). The camera must be assigned an IP address that is compatible with its LAN. By setting up port forwarding on the router, you can remotely access the cameras from outside of the LAN via the Internet. To remotely access the Web interface of the IP camera, please refer to *DDNS Settings* in *7.1.1 Network*. To set up port forwarding, please consult the manual of the router.

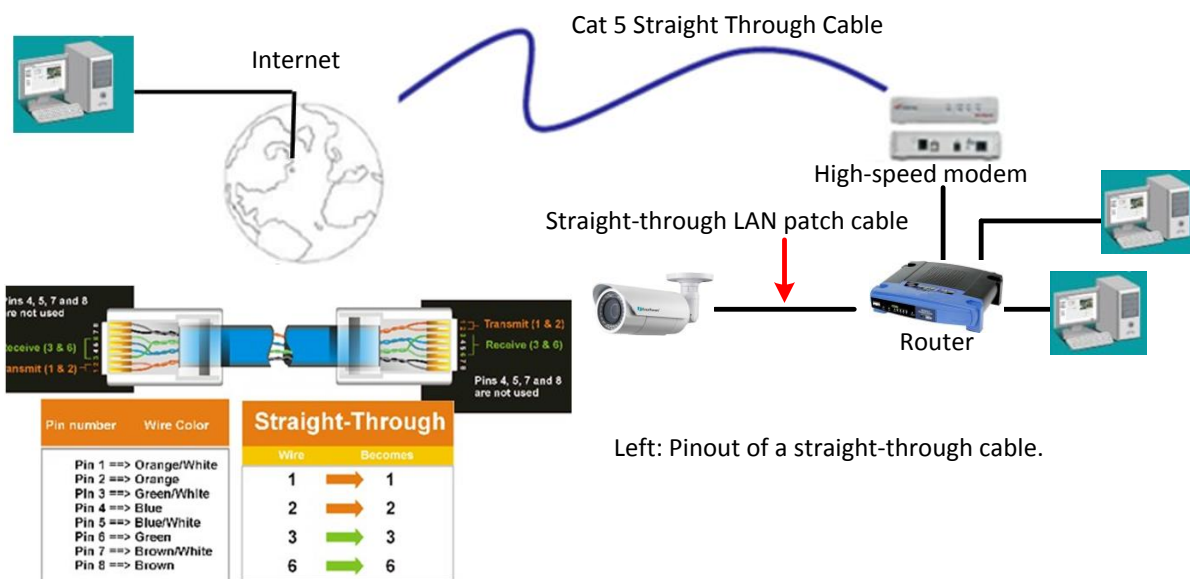

Direct High-Speed Connection

In a Direct High-Speed Connection, the camera connects directly to a modem without the need for a router. You need to set the static or dynamic WAN IP address assigned by your ISP (Internet Service Provider) in the camera’s configuration web pages. To access the camera, just type “http://xxx.xxx.xxx.xxx”, where xxx.xxx.xxx.xxx is the IP address given by your ISP. If you have a dynamic IP address, this connection may require that you use DDNS for a reliable connection. Please refer to *DDNS Settings in 7.1.1 Network*.



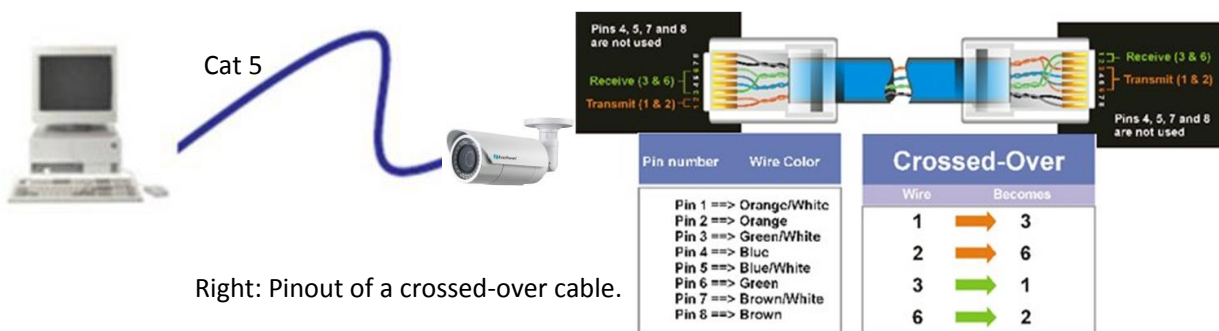

One-to-One Connection (Directly from PC to IP Camera)

You can connect directly without using a switch, router or modem. However, only the PC connected to the camera will be able to view the IP camera. You will also have to manually assign a compatible IP address to both the computer and the IP camera. Unless the PC has another network connection, the IP camera will be the only network device visible to the PC. See the diagram below:



5.4 Live View Window

When enter the Live View page, the control menu on the left side is hidden. Click **image adjustment**  icon to show the control menu. If you want to close the control menu, click **Close**  icon.

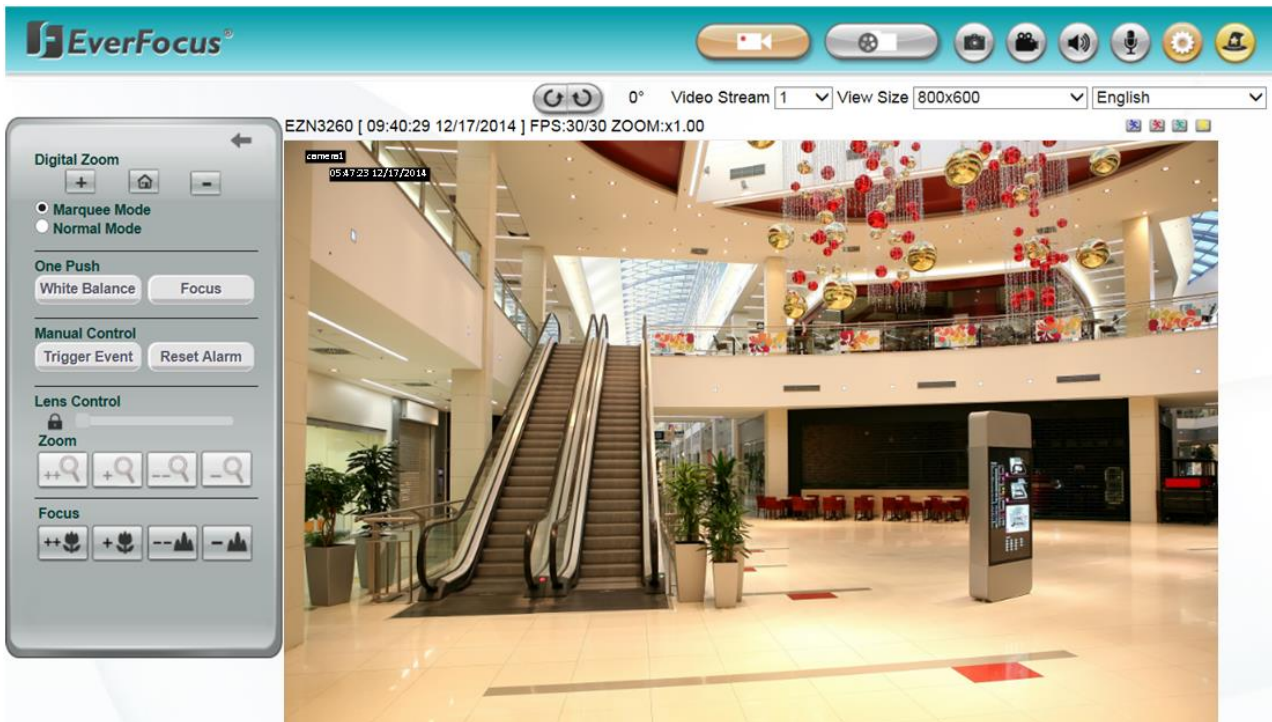

1. Live View

Click the **Live View** button to display the Live View window. If you experience video feed lag time (if connected via Internet), you can reduce the resolution or limit the number of streams. See [7.2.1 Streaming and Audio](#).

2. Playback

Click the **Playback** button to play back the recorded data directly from the on-camera micro SD / SDHC card. For this function to become active, you have to insert a micro SD / SDHC card into the micro SD / SDHC card slot on the camera (see [6.2 Setting up the Playback Function](#)). For the tested card brands, please refer to [Appendix](#).

3. Snapshot

Click the **Snapshot** button to take a snapshot. By default, the snapshot will be saved at C:\EverFocus\. To change the location, see [Record to Local](#) in [7.1.3 Storage](#).

Note: For Microsoft IE10 and above users, some settings have to be complete to enable this function (see [B. Snapshot/Record error message](#) in [10. Troubleshooting](#)).

4. **Record** 

Click the **Record** button to start / stop recording the current video stream. By default, this icon is only for one-minute video recording and the recordings will be saved at C:\EverFocus\. To change the recording time, see *File Size* in 7.1.3 *Storage*. To change the location, see *Record to Local* in 7.1.3 *Storage*. To record long-period recordings, please set up a recording schedule (7.3.2 *Schedule Settings*). To change the source video stream and recording format, see *Recording and Snapshot Settings* in 7.1.3 *Storage*.

Note: For Microsoft IE10 and above users, some settings have to be complete to enable this function (see *B. Snapshot/Record error message* in 10. *Troubleshooting*).

5. **Speaker / Microphone**  

Click the **Speaker** and **Microphone** buttons to switch the sound on/off for the speakers and microphones respectively (if such external devices have been connected to the camera directly or via the network). To activate the Audio function, the **Enable Audio** must be selected. See *Audio Settings* in 7.2.1 *Streaming and Audio*. Note that the camera provides the TRS line-in / out terminal I/O, therefore, TRS microphones / speakers with a (built-in) amplifier and external power supply are required.

6. **Setting** 

Click the **Setting** button to enter the Settings page (see 7. *Settings*).

7. **Wizard** 

Click the **Wizard** button to enter the Setup Wizard.

8. **Hallway Display (9:16):** Click the **Rotate** button 

to rotate the live image. The rotation degree will display next to the button. This function allows users to monitor vertically-oriented areas such as hallway, corridors and aisles.



Note: To achieve the best 9:16 display effect, it is recommended to:

1. Install the camera sideways by rotating the camera to the left or right by 90°.

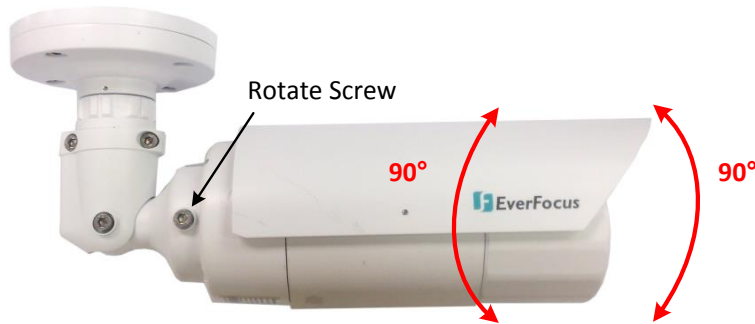

2. Select a 16:9 View Size (e.g. 1920x1080 / 1024x768).
3. Use the Rotate button.

9. Video Stream

Select the Video Stream (Stream 1 and Stream 2) that will be displayed in the live view window on the bottom. (see *7.2.1 Streaming and Audio*). The default setting is Stream 1 only. If extra streams required, EverFocus can customize the settings.

10. View Size

Use this to select the appropriate view size and shape of the live view window on the bottom. A smaller size might increase transmission speed and video quality.

11. Language

Click the Language drop-down list to select the desired language.

12. Digital Zoom

Click the zoom in / zoom out buttons to zoom in / out the camera live view. Click the Home button to go back to the home position.

Marquee Mode: Select this mode to drag around a portion of the live view window you want to zoom into with your mouse.

Normal Mode: Select this mode to set the zoom level in the magnified window. Clicking on the magnified image will re-center the image around that point.

13. One Push

The One Push buttons can be displayed on the live view window by enabling the **Show One Push Buttons** function in the Live View Layout Settings (see *7.1.4 Display and Overlay*).

White Balance: To enable the button (turned from faded to clear), on the Settings > Advanced > Camera Settings > Image, select **One Push** from the mode drop-down list in the White Balance Settings field. Once this is done, clicking the **White Balance** button on the Live View Window will instruct the camera to adjust the white balance settings, and these settings will be active until the button is clicked again. This is like a “semi-automatic” way to adjust white balance to suit the user, if the Auto or Manual mode does not give the result the user wants.

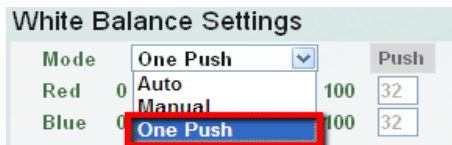

Focus: The **Focus** (Auto Focus) button is enabled by default on the Live View window. Click the Focus button to instruct the camera to focus automatically. To hide the **Focus** button on the Live View window, disable the **Show One Push Buttons** function in the Live View Layout Settings (see 7.1.4 *Display and Overlay*).

14. Manual Control



Click the  button to trigger an event directly from the window. If you have configured an event (in the Event List) that will trigger a reaction (like a recording) when a *Manual Trigger* event occurs, clicking this button will trigger that reaction. You can select what that reaction will be. You can, for instance, set the camera to record the audio/video feed to the micro SD card on board the camera. You can then click on the **Playback** button to open the Playback page and search for and play all such recordings that had been stored on the card. Such event actions will be effective once they have been configured in the Event List (see 7.3.2 *Event*).

Click the  button to reset the alarm output remotely.



15. Lens Control

The Lens Control buttons can be hidden on the Live View window by disable the **Show Lens Control Buttons** function in the Live View Layout Settings (see 7.1.4 *Display and Overlay*).

■ Zoom (Optical Zoom)

To adjust zoom buttons and slide bar, you need to click the **Lock**  icon to unlock first. Click the **Unlock**  icon again to lock the zoom functions. The slide bar can be used for major adjustment while zoom buttons are suitable for fine tuning. The bar value is defined by 1X, 2X and 3X values as shown below. Slide the bar to the desired value.



When using buttons to control the zoom in / out actions, the slide bar will act accordingly. Click and hold the  buttons to continuously zoom in / out. Click the  buttons to zoom in / out one step forward or backward.

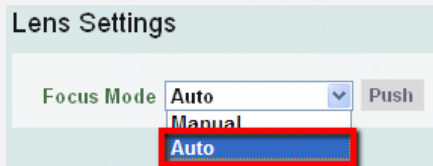

Note:

1. If you select **Auto** from the Focus Mode drop-down list, the camera will automatically adjust focus every time you click the Zoom in / out buttons.



2. It is recommended to adjust camera zoom only when necessary. Adjusting camera zoom in Day mode or Night mode may cause an unfocused camera when it automatically switches from day to night mode or from night to day mode. When unfocused camera symptom occurs, click the **Focus** button for the camera to automatically adjust the focus or click the Focus buttons to fine tune camera focus.

■ **Focus**

To use the buttons to adjust focus, click and hold the  buttons to continuously focus closer or farther. Click the  buttons to focus one step closer or farther.

16. Status Display (info line that can be placed above video box or at bottom of page)

This shows the name of the camera that is currently active or being configured, current date/time and current frame rate. You can activate these info displays in the Overlay Text Settings (see 7.1.4 *Display and Overlay*).

17. Event signal icons (above video screen)

When an alarm or motion event is triggered, a signal icon will appear at the top right of the Live View window to alert the user.

Alarm event icon  : When an alarm is triggered, this icon appears.

Motion detection icons  : The colors of these motion event icons correspond to the colors of the motion trigger areas you have configured in the Motion Settings (see 7.3.2 *Event*).

Recording icon  : When the camera is recording to a PC-based folder, this icon appears.

6 Playback

You can remotely play back the recordings stored in the on-camera micro SD card on the Web interface, or play back the recordings stored in the computer using the **ARV Viewer** included in the software CD.

Playback is designed as a quick way to check recent recordings that were triggered by Events that were configured to “Record to micro SD Card” in the Event Management (see 7.3.2 Event).

Note: The Playback page is only accessible once the on-camera micro SD card is inserted and active. Please refer to *Appendix A* for the tested card brands.

6.1 Remote Playback Using Playback Page

On the Live View Window, click the **Playback** button  to open the Playback page.

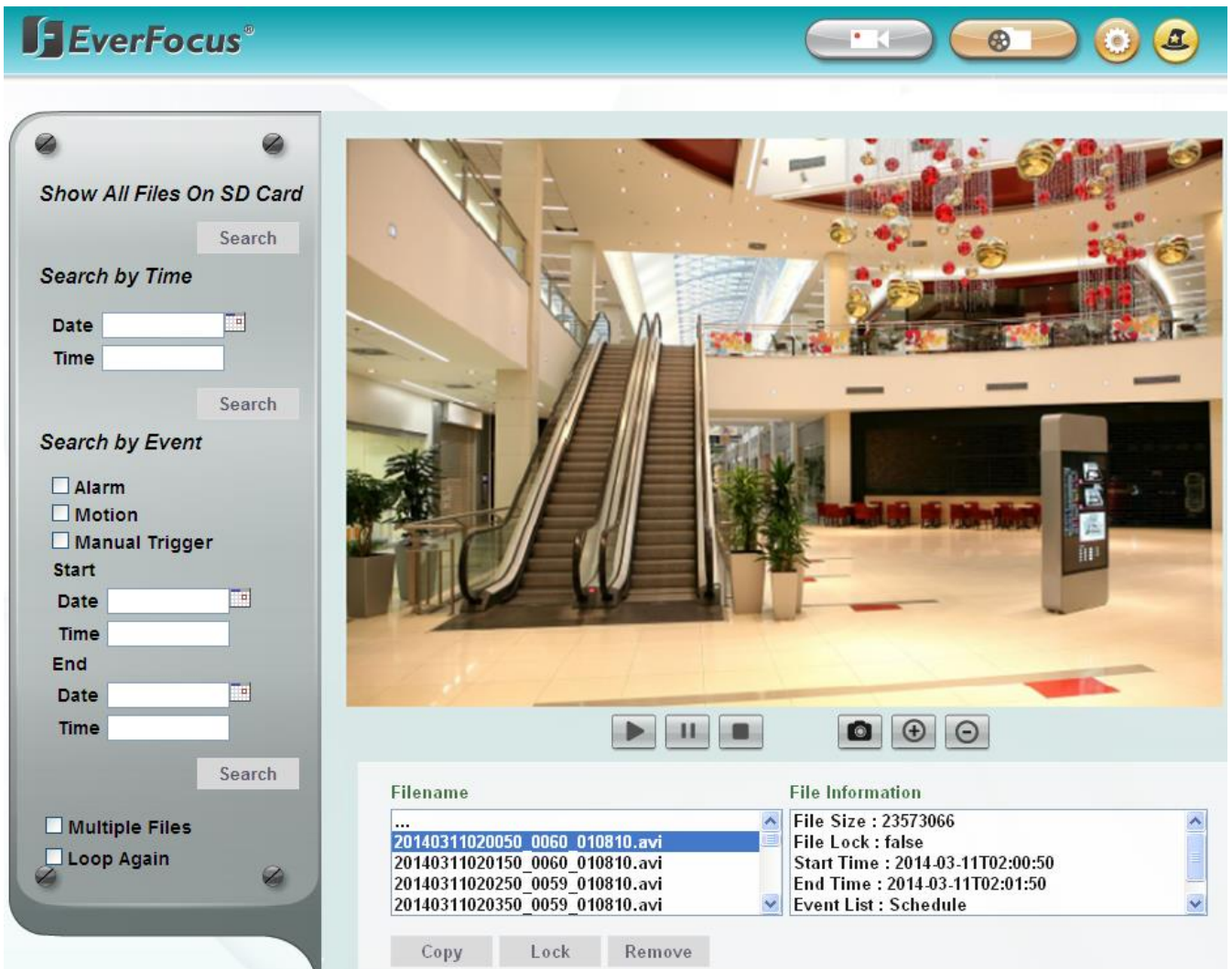

Filename	File Information
...	File Size : 23573066
20140311020050_0060_010810.avi	File Lock : false
20140311020150_0060_010810.avi	Start Time : 2014-03-11T02:00:50
20140311020250_0059_010810.avi	End Time : 2014-03-11T02:01:50
20140311020350_0059_010810.avi	Event List : Schedule

Search by File: Click the **Search** button to search for all recording files on the on-camera micro SD card. Search results will be displayed in the Filename area.

Search by Time: Click the **Date / Time** column and select the date and time from which you want to search until the present moment. Click **Search** to get your search results, which will be displayed in the Filename area.

Search by Event: Select the type of Event recordings you want to search for (Alarm, Motion, Manual Trigger) and then click the **Start Date / Time; End Date / Time** column to select the Start Time date/time and the End Time date/time of your search. Click **Search** to get your search results, which will be displayed in the Filename area.

Multiple Files: Check this box if you want the video player to play all the files in the selected folder. The files will be displayed in the Filename area.

Loop Again: Check this box if you want the video player to play the selected file over and over again.

Play: Once you have opened the file's folder and have clicked on the file to highlight it, its details will be displayed in the File Information area. You can now click **Play**  to play that specific file.

Pause: Click  to pause playing back.

Stop: Click  to stop playing back.

Snapshot: Click  to take a snapshot.

Zoom In: Click  to zoom in.

Zoom Out: Click  to zoom out.

Filename: This area will display a list of search results (recording files and folders). Folders (named with the recorded date) will be displayed first. Click on the folder and click on each subfolder until the recording files (.arv) in that folder is listed.

File Information: Click a file on the Filename list, the selected file information will be listed.

Copy: Click to copy the selected file to the computer-based folder of your choice. A browsing box will open so that you can search for the folder of your choice. You can use the ARV Viewer to play back the recordings recorded in your computer. For details on ARV Viewer, see *6.3 Playing Back Using ARV Viewer*.

Lock: Click to lock the selected file. This will protect that file from being overwritten during any overwrite procedure. The file will thus be saved on the micro SD card indefinitely. However, the file will still be deleted if the micro SD card is ever formatted.

Remove: Click to delete the selected file.

6.2 Setting up the Playback Function

Note that the Playback function will not be activated until the user has inserted a micro SD card in the camera's micro SD card slot. The card may also have to be formatted in the Secure Digital Card field (see 7.1.3 Storage). For the tested card brands, please refer to *Appendix*.

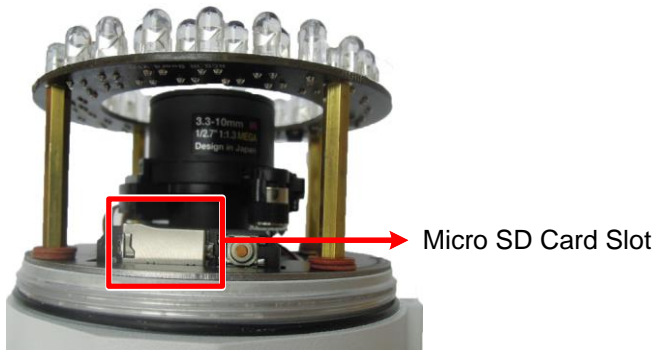

6.2.1 Inserting / Removing the micro SD Card

1. **To insert the micro SD card:** Remove the camera cover and insert the micro SD card into the micro SD card slot before powering on the camera.
2. **To remove the micro SD card:** Click the **Remove** button (Advanced tab > System Settings > Storage > Secure Digital Card) when the camera is powered on, the micro SD card information “micro SD card is not mounted” will display and the Remove button will change to **Attach**, and then you may remove the micro SD card. If you want to insert the micro SD card again, insert the micro SD card and then click the **Attach** button.

After inserting the micro SD card into the micro SD card slot, the **Playback** button on the Live View page should be activated. If not, click the **Refresh** button for the camera to detect the micro SD card. Then, the **Playback** button should be activated now.

Note: For the first-time user, click the **Format** button to format the card. All data on the disk **will** be deleted if the **Format** button is clicked.

6.2.2 Testing the Playback Function

- To test the Playback function (this is not required), set up a “Manual Trigger” Recording Event by clicking Event Settings > Event.

Event Management

Event List			
Name	Type	Notification	Enable
new event	Alarm Input	FTP,SD,syslog	Yes
new event1	Motion Detectio	syslog	Yes
new event2	Tampering Det	email	Yes

View 1 - 3 of 3

Event Name

Event Trigger Type Manual Trigger Motion Area1

Enable This event

Enable Re-trigger miniman interval between triggers second

Enable Pre-trigger Buffer

Enable Post-trigger Buffer

Notification Over

Log

Trigger Alarm Output Duration Time second

Send Mail Notification

Upload to FTP

Record to micro SD Card

Network Alarm

Create Remove
Edit Cancel

Event Trigger Settings

Input 1 Trigger Type Normal Open

Output 1 Contact Type Normal Open

Apply Cancel

Event Trigger Settings

Input 1 Trigger Type Normal Open

Output 1 Contact Type Normal Open

Apply Cancel

Tamper Detection Settings

Tamper Duration Time second

Apply Cancel

Trigger Options Settings

Pre-trigger Buffer second

Post-trigger Buffer second

Apply Cancel

2. Give the event a name, like “1”.
3. In the “Event Triggered Type” field, click on Manual Trigger.
4. Below this, check “Enable This Event”, “Enable Post-trigger Buffer”, and “Record to micro SD Card”. For Alarm Input, Manual Trigger, and Tampering Detection trigger types, multiple events can be created on the Event List but only one event can be enabled. For example, if you create three Alarm Input trigger events, only one event under this trigger type can be enabled. The option of **Enable This Event** for the rest of two Alarm Input events will be grayed out and display “This Trigger Type has already been enabled.” To enable another event under the same type, uncheck to disable the event first and check the desired event.
5. To save your settings, click the **Create** button, and the Event will be listed in the Event List.
6. Look at the “Post-trigger Buffer” at the bottom to make sure the buffer time is set to 10 seconds. Click the **Apply** button.
7. Click the **LiveView** button to go back to the Live View page.
8. Get ready to click the **Trigger Event** button on the Live View page. Before you do, see if you can find something in the view screen that will give you a visual time marker. For instance, if you can get your hand in front of the camera’s lens, get ready to count down on your fingers.
9. Click the **Trigger Event** button and slowly count down on your fingers in front of the lens (if you are able to do so – if not, try to find visual cues on the view screen that will help you to mark the moment you pushed the trigger). The recording period will be as long as the buffer time you selected – the default period is 10 seconds.
10. Click the **Playback** button to open the Playback page.
11. There are different ways to search for recording files on the camera’s micro SD card (i.e. the Playback memory). For a recent recording like your test event, simply click the “Search” button under the “Show All Files on micro SD Card” header.
12. If the micro SD card is active and formatted correctly, the recording folder’s name (the recording day’s date) will appear in the Filename area. Click on this folder to open it. If there are sub-folders, click on the bottom one (the most recent would be at the bottom) until you can click on a file that cannot open to another sub-level and shows data in the File Information area to the right. This would be the file of the most recent recording event.
13. To play this file, click the **Play** button below the video box. The test footage you have recorded should start playing. Play time should be 10 seconds if you left the Post-trigger Buffer as 10 seconds.

6.3 Playing Back Using ARV Viewer

You can play back the recordings stored in the computer using the **ARV Viewer**  included in the software CD. To store the recordings in the computer, please refer to Copy in *6.1 Remote Playback Using Playback Page*.



No	Item Name	Descriptions
1	Snapshot	Click to take and save a snapshot.
2	Load File	Click to load the recordings for playing back.
3	Convert ARV to AVI	Convert the recording from ARV format to AVI format.
4	Ceiling Mount	Click to enable the Ceiling Mount view modes on the right-side bar. Please refer to the View Mode Table below for more details.
5	Desk Mount	Click to enable the Desk Mount view modes on the right-side bar. Please refer to the View Mode Table below for more details.
6	Wall Mount	Click to enable the Wall Mount view modes on the right-side bar. Please refer to the View Mode Table below for more details.
7	Fisheye View	Click to display fisheye view.
8	Single View	Click to display single view.
9	Quad View	Click to display quad view.
10	Dual 180 Degree	Click to display dual 180 degree view.

11	360 Degree	Click to display 360 degree view.
12	Wall 180 Degree	Click to display 180 degree view.
13	Playback Time	Display the playback time.
14	Total Time of Recording	Display the total time of the recording.
15	Stop	Click to stop playing the recording.
16	Step Reverse	Click to display the previous frame.
17	Play	Click to play back the recording.
18	Pause	Click to pause the recording.
19	Step Forward	Click to display the next frame.

Note: No. 4 – 12 are only available for Fisheye cameras.

7 Settings

Click the **Setting** button  on the Live View Window to enter the setting submenu. There are two tabs: Basic and Advanced on the left-side bar. You can set up the basic camera settings in the **Basic** tab. To further set up comprehensive camera settings, click the **Advanced** tab, which includes all the settings to be configured. The chapters below describe the detailed information of the Advanced tab.

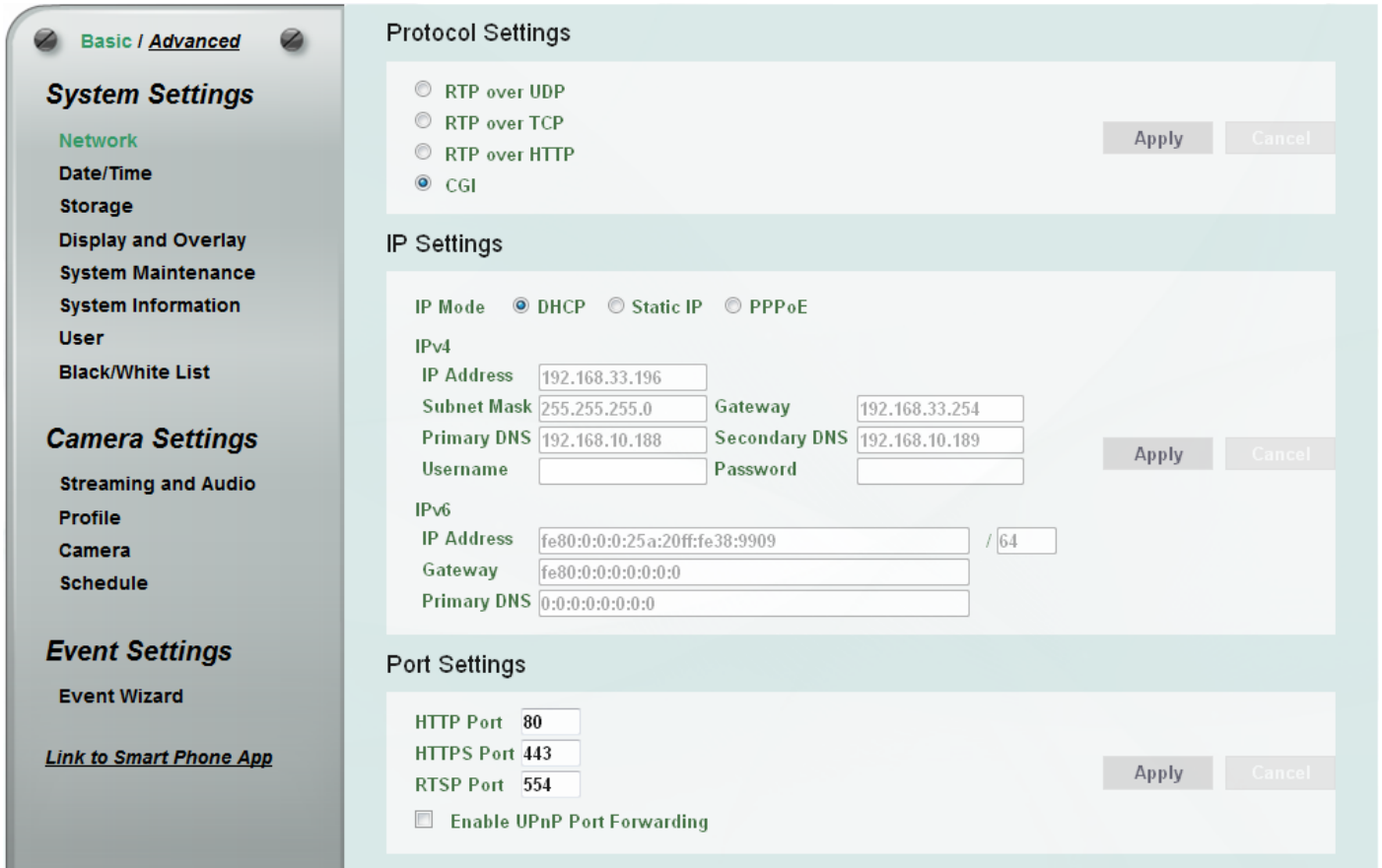

The screenshot displays the camera's settings interface. On the left is a sidebar with a menu:

- Basic / **Advanced**
- System Settings
 - Network
 - Date/Time
 - Storage
 - Display and Overlay
 - System Maintenance
 - System Information
 - User
 - Black/White List
- Camera Settings
 - Streaming and Audio
 - Profile
 - Camera
 - Schedule
- Event Settings
 - Event Wizard
- [Link to Smart Phone App](#)

The main content area is divided into three sections:

- Protocol Settings:**
 - RTP over UDP
 - RTP over TCP
 - RTP over HTTP
 - CGI
- IP Settings:**
 - IP Mode: DHCP Static IP PPPoE
 - IPv4:
 - IP Address: 192.168.33.196
 - Subnet Mask: 255.255.255.0
 - Gateway: 192.168.33.254
 - Primary DNS: 192.168.10.188
 - Secondary DNS: 192.168.10.189
 - Username: [] Password: []
 - IPv6:
 - IP Address: fe80:0:0:0:25a:20ff:fe38:9909 / 64
 - Gateway: fe80:0:0:0:0:0:0:0
 - Primary DNS: 0:0:0:0:0:0:0:0
- Port Settings:**
 - HTTP Port: 80
 - HTTPS Port: 443
 - RTSP Port: 554
 - Enable UPnP Port Forwarding

7.1 System Settings

7.1.1 Network

Protocol Settings

RTP over UDP
 RTP over TCP
 RTP over HTTP
 CGI

IP Settings

IP Mode DHCP Static IP PPPoE

IPv4

IP Address
 Subnet Mask Gateway
 Primary DNS Secondary DNS
 Username Password

IPv6

IP Address / 64
 Gateway
 Primary DNS

Port Settings

HTTP Port
 HTTPS Port
 RTSP Port

Enable UPnP Port Forwarding

Multicast Settings

Enable Multicast Multicast IP
 Port Time to Live

DDNS Settings

Enable Service ISP
 www.everfocusddns.com

IP Camera Name .everfocusddns.com

www.sitelutions.com www.dyndns.com www.no-ip.com

Record ID FQDN
 Username Password

HTTPS Settings

Create Certificated Mode Self-signed Certificated
 Certificate Request

Country Name
 State or Province Name
 Locality Name
 Organization Name
 Organization Unit Name
 Common Name
 Email
 Validity Day

Created Request

Install Signed Certificated

Install Certificated Info

Property Information

QoS Settings

Enable QoS/DSCP

Live video :
 Live audio :
 Management :

【Protocol Settings】 You can transmit the data stream from the IP cameras using the RTSP (Real Time Streaming Protocol) on the network. The RTSP is a protocol that allows you to access video streams by using the compatible media players. Click **Apply** to apply the changes or **Cancel** to cancel the changes and return to the previous settings.

- **RTP over UDP:** The RTSP protocol uses UDP for camera data stream transmission.
- **RTP over TCP:** The RTSP protocol uses TCP for camera data stream transmission.
- **RTP over HTTP:** The RTSP protocol uses HTTP for camera data stream transmission.
- **CGI:** use CGI for camera data stream transmission.

【IP Settings】 Enter the IPv4 / IPv6 details in this area, which applies to your system. Click **Apply** to apply the changes or **Cancel** to cancel the changes and return to the previous settings.

■ **IPv4:**

IP Mode: Refer to the network administrator for these settings of the server. **Default: DHCP.**

- **DHCP:** This setting lets the system use an automatically assigned (dynamic) IP address. This address can change under certain circumstances. For instance, when the camera's network switch/hub has to be rebooted. Do not assign to the DHCP server the same IP addresses used for the other network cameras and PCs with unique IP addresses.
- **Static IP:** The user can manually set the Static IP address. This type of address is stable and cannot change, but the user has to make sure there are no address conflicts with other network-connected devices.
- **PPPoE:** This is a DSL-connection application. The ISP will ask the user to input a username and password. Contact your ISP for these details.

IP address: When DHCP is not used, the user needs to manually enter the IP address of the camera. Do not enter an IP address that is already used for your computer or other network cameras.

Subnet Mask: This field is used to set the subnet mask for your network, so that the IP camera will be recognized within the network. Example: 255.255.255.0. When DHCP is selected, the DHCP server will assign this value automatically.

Gateway: This field is used to set the gateway for your network so that the IP camera will be recognized within the network. When DHCP is selected, the DHCP server will assign this value automatically.

Primary DNS: Enter the IP address of the DNS server if this is provided by an ISP.

Secondary DNS: If your ISP provided you with a secondary DNS address, please enter it here.

Username: Enter the account's username (used only for PPPoE).

Password: Used only for PPPoE.

- **IPv6:** Enter the IPv6 details in this area, if this applies to your system.

【Port Settings】 Enter the HTTP, HTTPS and RTSP port numbers. Check the **Enable UPnP Port Forwarding** box to enable the UPnP function. Click **Apply** to apply the changes or **Cancel** to cancel the changes and return to the previous settings.

Promoted by the UPnP Forum (Universal Plug and Play), the UPnP is a networking architecture providing compatibility among networked devices listed in the networked device table. Enable the UPnP function means you can directly connect the cameras listed in the networked device table by clicking on them.

Note:

1. For the UPnP function to work, an UPnP-enabled router is required.
2. The UPnP function may fail owing to the compatibility between the camera and the router.

【Multicast Settings】 Enable if required, fill in the setting options and click **Apply** to save. For more details, please refer to *Appendix B. Enabling the Multicast Function*.

Enable Multicast: Check the box to enable the Multicast function.

Multicast IP: Fill in the multicast IP address. IP addresses in the range of 224.0.0.0 through 239.255.255.255 are reserved for multicasting. For devices, you can use 225.x.x.x - 232.x.x.x and 234.x.x.x - 238.x.x.x. Click [here](#) for more details.

Port: Change the port number if necessary. The port number has set to 50000 by default.

Time to Live: Input a Time-To-Live (TTL) value. The TTL value specifies the number of routers (hops) that multicast traffic is permitted to pass through before expiring on the network.

【DDNS Settings】This function can only be set up in the **Advanced** tab. DDNS (Dynamic Domain Name System) is a service used to map a domain name to the dynamic IP address of a network device. You can set up the DDNS service for remote access to the IP camera. DDNS assigns a domain name (URL) to the IP camera, so that the user does not need to go through the trouble of checking if the IP address assigned by DHCP Server has changed. Once the IP is changed, the IP camera will automatically update the information to the DDNS to ensure it is always available for remote access. Before enabling the following DDNS function, user should have applied for a host name from the DDS service provider's website. We support these four DDNS server providers: www.everfocusddns.com, www.sitelutions.com, www.dyndns.com, and www.no-ip.com

Note: We highly recommend that you use xxx.everfocusddns.com for the simplicity of setting up your IP cameras.

- **Enable Service ISP:** Check this box to enable the DDNS function. You can either apply for a host name from **EverFocus** or **other DDNS server providers**.
- **From EverFocus:** If you choose the EverFocus DDNS server, you can obtain a free host name from EverFocus. To obtain a free host name from EverFocus, type a desired host name in the textbox, click the **Register / Update** button, and then click the **Apply** button.
- **From other DDNS server providers:** To obtain a domain name from one of the three DDNS server providers, you have to register your name with the provider first, and then select the provider and fill in the required information. Please refer to the specific DDNS company's website for further information.

Record ID: Type the record ID if provided by the DDNS server provider.

FQDN: Type the fully qualified domain name applied from the DDNS server provider. For example, xxxx.dyndns.com

Username / Password: Type the login account of your DDNS server provider.

Click **Apply** to apply the changes or **Cancel** to cancel the changes and return to the previous settings.

Note:

1. In order to support the full functionality of the camera, you must open the port numbers (80, 554, 443) on the router for remote access to the IP camera. This function is available on most routers in the market and is often known as "Port Forwarding". To set up Port Forwarding, please consult the manual of the router.
2. In certain router models, it is possible that you will not be able to access the camera using DDNS while inside the router's network. Please try using a PC located outside of your router's network.

Default Ports on All EverFocus IP Cameras:

HTTP: 80

RTSP: 554

HTTPS: 443

【HTTPS Settings】 This function can only be set up in the **Advanced** tab. Hypertext Transfer Protocol Secure (HTTPS) is a combination of the Hypertext Transfer Protocol and the SSL / TLS protocol that provides encrypted communication and secure identification of a network web server. Before using the HTTPS function for communication with the IP camera, a Certificate must be created first. There are two ways to create and install a certificate: **Self-Signed Certificated** and **Certificate Request**.

Self-Signed Certificated

Please note that even though self-signed certificates are free and offer some protection, true security is only implemented after the installation of a signed certificate issued by a certificate authority.

1. Select **Self-Signed Certificated** and fill in the following information.

Create Certificated Mode	<input checked="" type="radio"/> Self-signed Certificated <input type="radio"/> Certificate Request
Country Name	TW
State or Province Name	TPE
Locality Name	TPE
Organization Name	EF
Organization Unit Name	PM
Common Name	1
Email	everfocus@everfocus.c
Validity	7 Day

2. Click the **Apply** button. The subject line will be displayed in the Install Certificated Info field.

Install Certificated Info	<input type="text"/>	<input type="button" value="Property"/>	<input type="button" value="Remove"/>
---------------------------	----------------------	---	---------------------------------------

3. Click the **Property** button, a pop-up window appears to display the details of the certificate.

Property Information
Install Certificated Info Property
Not Valid Before : Thu Jan 1 00:00:00 1970
Not Valid After : Thu Jan 1 00:00:00 1970
Subject :
Certificated (PEM format) :

4. To optionally create and install other certificates, remove the existing one by clicking the **Remove** button to erase the certificate.
5. On the Web page, change the address from “http://” to https:// in the address bar and press Enter on the keyboard. Some Security Alert dialogs will pop up. Click **OK** or **Yes** to enable HTTPS.

Create Certificate Request

You can apply for an official certificate from an issuing Certificate Authority.

1. Select **Certificate Request** and fill in the following information.

Create Certificated Mode	<input type="radio"/> Self-signed Certificated <input checked="" type="radio"/> Certificate Request
Country Name	TW
State or Province Name	TPE
Locality Name	TPE
Organization Name	EF
Organization Unit Name	PM
Common Name	1
Email	everfocus@everfocus.c
Validity	7 Day

2. Type the required Certificate information and then click the **Apply** button. The subject line will be displayed in the Created Request field

Created Request	<input type="text"/>	<input type="button" value="Property"/>	<input type="button" value="Remove"/>
-----------------	----------------------	---	---------------------------------------

3. Click the **Property** button, a pop-up window appears to display the details of the certificate.

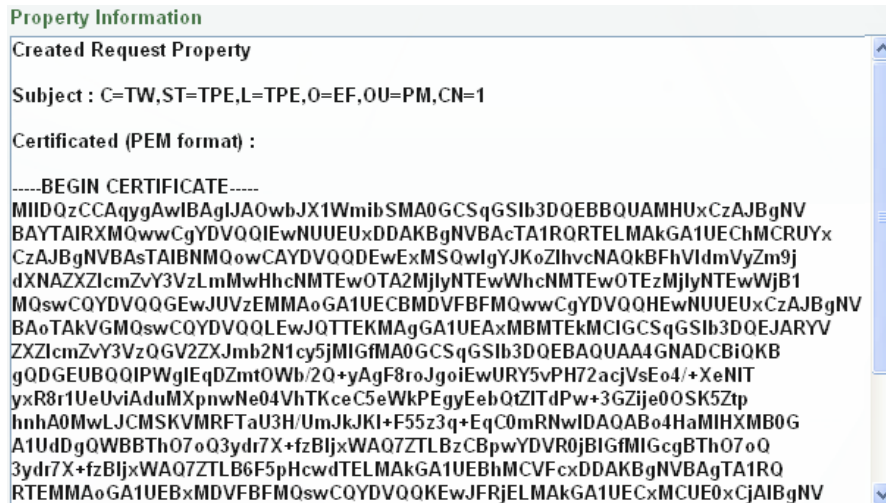

4. To optionally create and install other certificates or request, remove the existing one by clicking the **Remove** button to erase the certificate or request.
5. Copy the contents of the Certificate request (in PEM format) and paste it to the certificate request field on the Web page of the 3rd party certification authority such as Symantec VeriSign. Wait for the certificate authority to issue an SSL/TLS certificate and then download the issued certificate on your computer.
6. In the Install Signed Certificated field, click the **Browse** button to search for the issued certificate, and then click the **Upload** button to import the certificate. Once the certificate has been uploaded, this field will show the subject line of the certificate.

【QoS Settings】 This function can only be set up in the **Advanced** tab used to set up the priority of package transmission. Check the Enable QoS / DSCP box and then adjust the value from 0 – 64 for Live video, Live audio and Management (UI operation). The higher the value, the higher the priority. Click **Apply** to save the changes.

7.1.2 Date / Time

You can set up the system’s time on this page.

Note: Before start operating the IP camera, please make sure the camera date and time are correct.

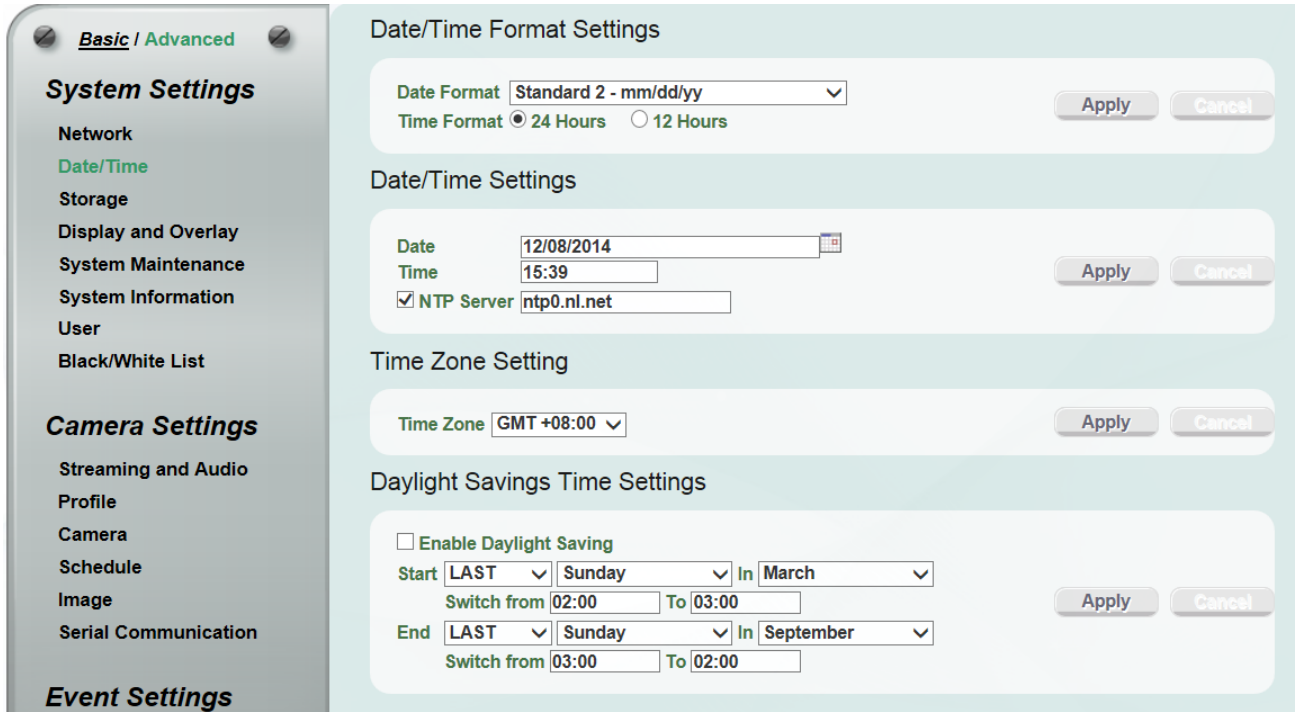

【Date/Time Format Settings】 Select the desired Date / Time format and then click the **Apply** button. To enable displaying the date and time information on the Live View Window, you have to check the **Date/Time** box in the Overlay Text Settings (see 7.1.4 Display and Overlay).

【Date/Time Settings】

- **Date:** Set the date by clicking the calendar. Click **Apply** to save the setting.
- **Time:** Click time to set desired hour and minute. Click **Apply** to save the setting.
- **NTP:** Enter the Network Time Protocol server, if applicable. The camera’s time will be automatically adjusted by synchronizing with the NTP server. Click **Apply** to save the setting.

【Time Zone Setting】 Set the time zone of the camera’s location. Click **Apply** to apply the changes or **Cancel** to cancel the changes and return to the previous settings.

【Daylight Savings Time Settings】 Click **Enable Daylight Saving** to enable this schedule, and select the dates when the region’s daylight saving period begins and ends. Click **Apply** to apply the changes or **Cancel** to cancel the changes and return to the previous settings.

7.1.3 Storage

You can configure the recording path / format, source video stream and micro SD card settings on this page.

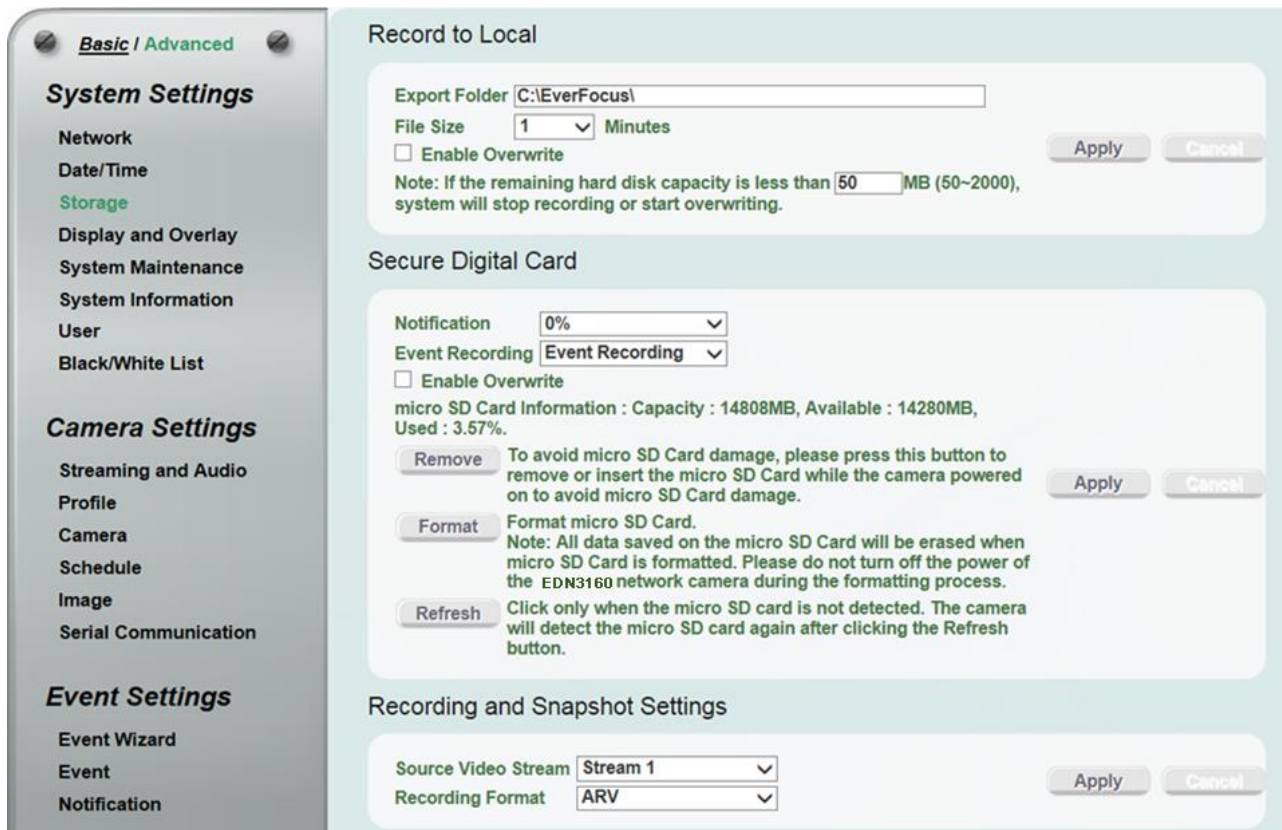

【Record to Local】This function can only be set up in the **Advanced** tab. You can configure the storage path for storing the recordings / snapshot on your PC.

- **Export Folder:** Type the storage path for storing the recordings / snapshot.
- **File size:** The user can limit the size of each recorded file here (in minutes). Once you click the **Record** button on the Live View window, the camera will start recording the live stream to your computer. When a single recording file exceeds the time you set, the system will create a new file to save that data to.
- **Enable Overwrite:** Check the box for overwriting recording / snapshot file when the disk storage capacity is full. The user can set the storage capacity limitation in the in-sentence box below the Enable Overwrite setting: “If the remaining hard disk capacity is less than ____ MB (50 ~ 2000),... “

Click **Apply** to apply the changes or **Cancel** to cancel the changes and return to the previous settings.

【Secure Digital Card】

- **Notification:** Select the percentage of storage space that should be left on the card before the camera notifies you of the impending storage shortage or overwrite.
- **Event Recording:** Select the location where you want the camera to send the impending storage shortage text notification to.
 - **FTP Back Up Only:** Select to send the impending storage shortage text notification to the FTP server entered in the FTP Repository Settings (see 7.3.3 *Notification*).
 - **Event Recording:** Select to send the impending storage shortage text notification to the checked locations in the Event Management (see 7.3.2 *Event*).

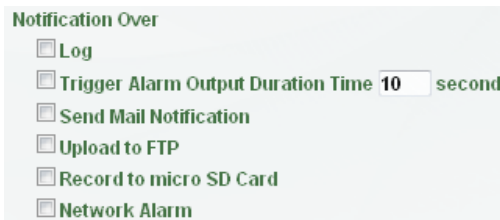

- **Both:** Select to send the impending storage shortage text notification to the FTP or the selected locations in the Event Management (see 7.3.2 *Event*).
- **Enable Overwrite:** Check the box for overwriting files when the micro SD card is full.

Micro SD Card Information: If a micro SD card has been inserted to the micro SD card slot of the camera, the micro SD card information will be displayed in this field.

 - **Remove:** Click before removing the card from the system (6.2.1 *Inserting / Removing the micro SD Card*).
 - **Format:** For the first-time user, click to format the card. All data saved on the micro SD card will be removed if the card is formatted (6.2.1 *Inserting / Removing the micro SD Card*).
 - **Refresh:** Click the button when the micro SD card is not detected.

Click **Apply** to apply the changes or **Cancel** to cancel the changes and return to the previous settings.

【Recording and Snapshot Settings】 Select the desired video stream and recording format. The video stream can be configured in 7.2.1 *Streaming and Audio*. Click **Apply** to apply the changes or **Cancel** to cancel the changes and return to the previous settings.

7.1.4 Display and Overlay

You can configure the recording path / format, source video stream and micro SD card settings on this page.

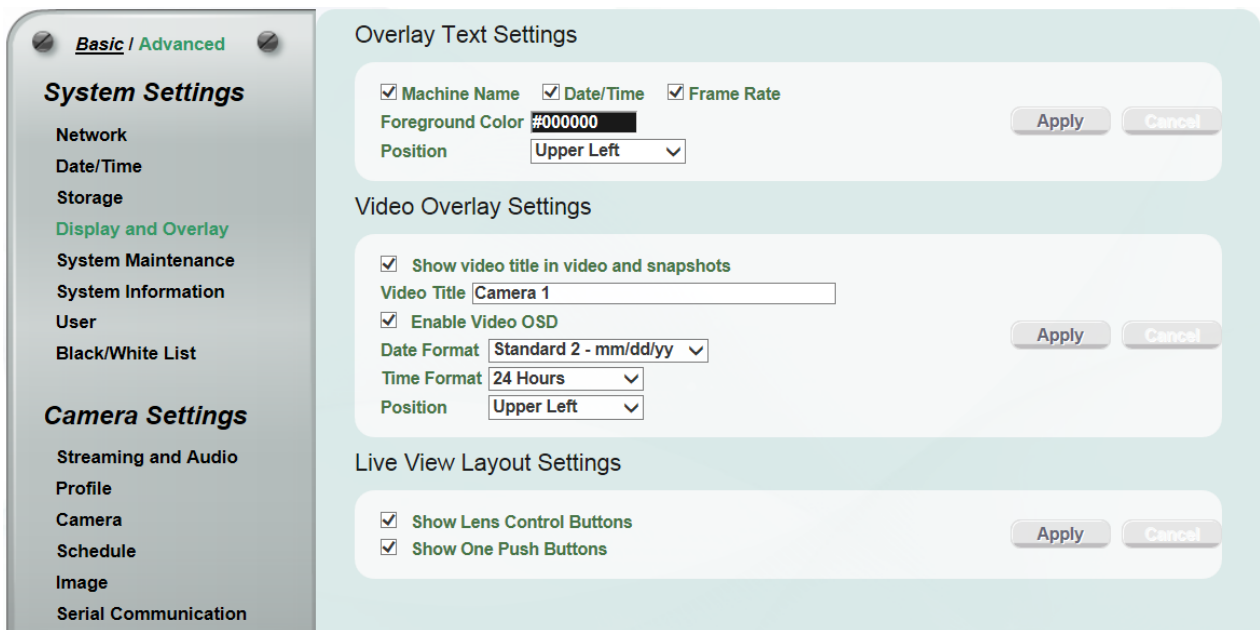

【Overlay Text Settings】 Check the boxes to display the information on the Live View Window. The information will only be displayed on the Live View Window and will not be displayed on the live view video images nor snapshots. To change the foreground color of the text, directly click on the box and then select a color. Select a position where you want the information to be displayed on the Live Window. To change the Machine Name, see *Machine Name* in 7.1.5 System Maintenance. To change the day and time setting, see 7.1.2 Date / Time. Click **Apply** to apply the changes or **Cancel** to cancel the changes and return to the previous settings.

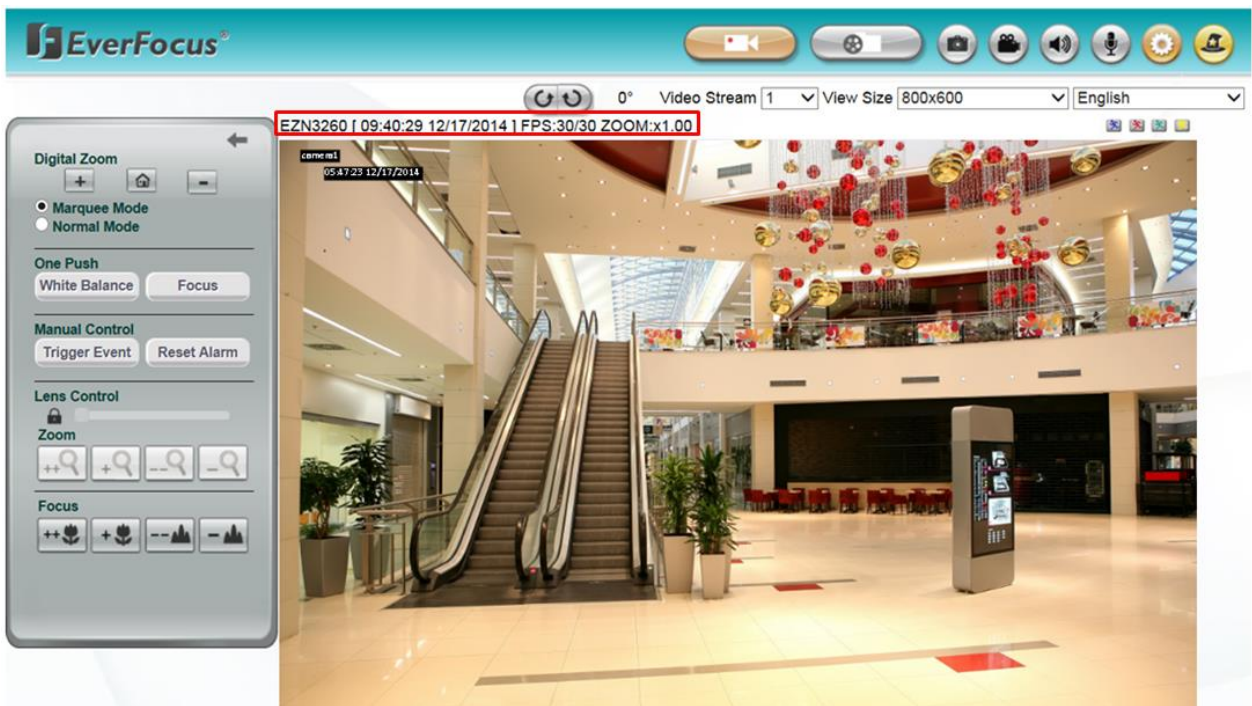

【Video Overlay Settings】 Check the boxes to enable displaying video title or date/time on the live view video images. Click **Apply** to apply the changes or **Cancel** to cancel the changes and return to the previous settings.



- **Show video title in video and snapshots:** Check the box to enable displaying video title on the live view video images and snapshots. To change the title, type a name in the **Video Title** column.
- **Enable Video OSD:** Check the box to enable displaying date/time information on the live view video images. Select the desired **Date/Time Format**.
Position: Select a position where you want the video title or date/time information to be displayed on the live view video images.

【Live View Layout Settings】 Check the boxes if you want to show the **Lens Control** or **One Push** buttons on the Live View Window. Uncheck to hide the functions. Click **Apply** to apply the changes or **Cancel** to cancel the changes and return to the previous settings.

7.1.5 System Maintenance

You can configure the recording path / format, source video stream and micro SD card settings on this page.

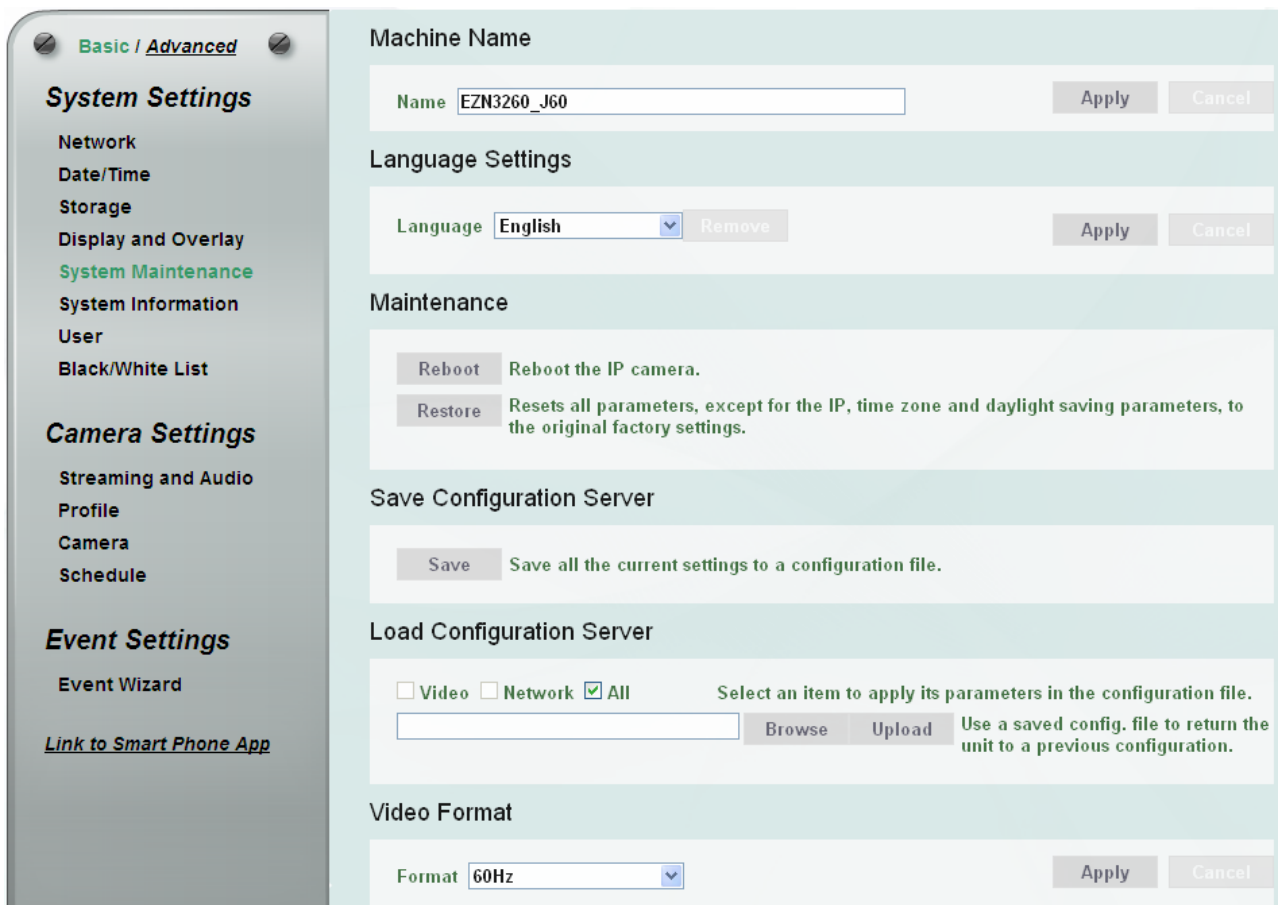

【Machine Name】 If required, enter a new name for the machine. This name will be visible in the Machine Name field of the IP Utility software, which is included in the software CD or from the Website of EverFocus (click [here](#) to download. Please refer to 5. Accessing the User Interface). Click **Apply** to apply the changes or **Cancel** to cancel the changes and return to the previous settings.

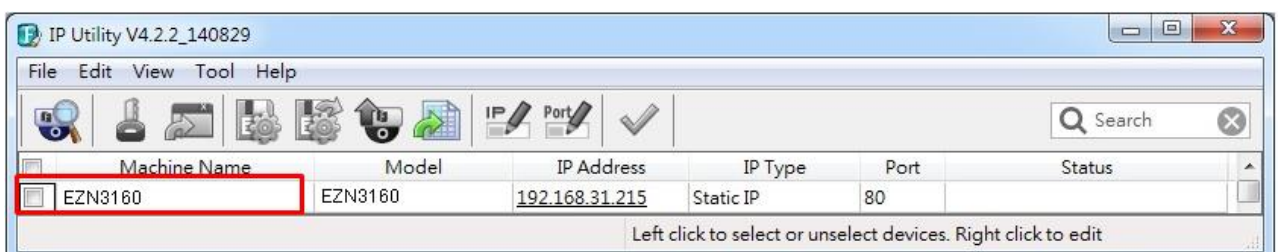

【Language Settings】 Select the language to be displayed on the Web interface of the IP camera. The default language is English.

To add a new language not listed in the current Language list, click the **Browse** button to locate the new language file (.evb) on your computer and then click the **Upload** button. Updated language files might be available on the manufacturer's website. Contact your vendor if required.

Click **Apply** to apply the changes or **Cancel** to cancel the changes and return to the previous settings.

Note: Uploading a new language file will cause the system to reboot automatically. Please create a new network connection to the IP camera when the reboot is complete.

【Maintenance】

- **Reboot:** Click to reboot the unit without changing any of the settings. Use this function if the unit is not behaving as expected.
- **Restore:** Click to restart and reset most of the current settings to their factory default values. The only settings that will not be changed to default are: IP Settings and DDNS Settings.
- **Initialize:** This function can only be set up in the **Advanced** tab. This button should be used with caution. Clicking this button will return all of the camera's settings, including the IP address, to the factory default values. The camera will then have to be reconfigured.

【Save Configuration Server】

Save: To make a backup file of the machine's current configurations, click this button to save all the configurations to a configuration file. This will enable the user to reload these configuration settings if the settings are changed and there is unexpected behavior.

【Load Configuration Server】

Select **Video** to apply only the video parameters from the configuration file to the system. Select **Network** to apply only the network parameters from the configuration file to the system. Select **All** to apply all the parameters from the configuration file to the system.

Browse: Click the **Browse** button to locate the saved config. File.

Upload: Click the **Upload** button to restore the system based on the selected parameters (Video, Network or All).

【Video Format】 Select 60Hz (NTSC) or 50Hz (PAL) for your local scanning system. Click **Apply** to save the setting.

【Upgrade Firmware】 This function can only be set up in the **Advanced** tab. Click the **Browse** button to find a previously prepared firmware upgrade file. Click the **Upload** button to install the new firmware.

Note:

1. Do not disconnect power to the unit during the upgrade sequence. The unit will reboot automatically after the upgrade has completed (1-5 minutes).
2. During the upgrade process, all event recording actions will be stopped. Event recording actions will resume after the camera is rebooted.
3. If the *"File Error, Please re-login!!"* warning message appears when upgrading the firmware, please try the following instructions:
 - a. Go to Internet Explorer > Tools > Internet Option > Security > Custom.
 - b. Find and enable the **Include local directory path when uploading files to a server**.

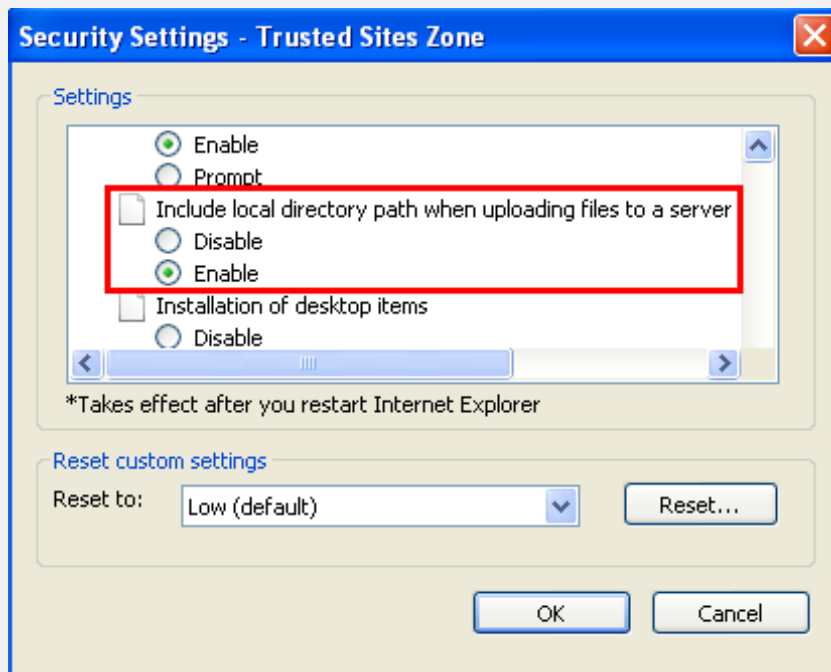

7.1.6 System Information

You can see the system information and log information displayed on this page.

The screenshot shows the 'System Information' page in the EverFocus web interface. On the left is a navigation menu with categories like System Settings, Camera Settings, and Event Settings. The 'System Information' option is highlighted. The main content area is divided into two sections: 'System Status' and 'System Log'.

System Status

Firmware Version	2.0.1_150312
Hardware Version	J60
MAC Address	00:11:14:12:06:8f
Model Name	EZN3260
TV Out Format	NTSC
Uptime	up 3:30

System Log

001	2015-03-25	10:07:08	Device boots up
002	2015-03-19	03:49:25	Power loss
003	2015-03-12	18:59:53	Set Cameras configuration: Video configuration setting. (user1/ [::ffff:192.168.0.111])
004	2015-03-12	10:53:51	Device boots up
005	2015-03-12	09:19:14	Power loss
006	2015-03-12	09:16:11	Device boots up
007	2015-03-12	09:13:55	Firmware update. (user1/[::ffff:10.0.0.243])
008	2015-03-12	09:13:06	Device boots up
009	2015-03-04	10:22:53	Firmware update. (user1/[::ffff:192.168.0.111])
010	2015-03-04	10:21:23	Device boots up
011	2015-03-03	09:19:09	Power loss
012	2015-03-03	09:17:05	Device boots up
013	2015-03-03	08:50:59	Power loss
014	2015-03-03	08:48:55	Device boots up
015	2015-03-03	08:48:07	Loading factory default. (user1/[::ffff:192.168.88.29])
016	2015-03-03	08:46:55	Device boots up
017	2015-03-03	07:51:08	Device boots up
018	2015-03-03	07:50:19	Loading factory default. (user1/[::ffff:192.168.1.25])
019	2015-03-03	07:50:12	Set Cameras configuration: Video configuration setting. (user1/ [::ffff:192.168.1.25])
020	2015-03-03	07:47:50	Device boots up
021	2015-02-16	10:48:30	Device boots up
022	2015-02-16	10:25:40	Device boots up

An 'Export Log' button is located at the bottom right of the log list.

【System Status】 Displayed the system information. The values cannot be changed on this page. The Uptime represents the period since the camera has been powered on. For example, up 7:48 represents the camera has been powered on for 7 hours and 48 minutes.

【System Log】 Displayed the sequence number, date, time and event messages of the log event. The log will display the last 256 log events. Click the **Export Log** button to export the system log event list into a “.txt” file and select the location where the exported log file will be saved to. Click the **Clear Log** to erase all the log data from the camera. The system will be required to reboot after clicking the Clear Log button.

7.1.7 User

The system administrator can create up to ten user accounts on this page.

User Management

Account	Authority	Description	Status	Enable micro SD Card
user1	Supervisor	user1	Active	Yes
user2	Guest	user2	Disable	No
user3	Guest	user3	Disable	No
user4	Guest	user4	Disable	No
user5	Guest	user5	Disable	No
user6	Guest	user6	Disable	No
user7	Guest	user7	Disable	No
user8	Guest	user8	Disable	No
user9	Guest	user9	Disable	No
user10	Guest	user10	Disable	No

View 1 - 10 of 10

Account:

Password:

Confirm Password:

Authority:

Description:

Status:

Enable micro SD Card

Buttons: Create, Remove, Edit, Cancel

Anonymous Settings

Anonymous viewer login

Note: To protect your camera from begin taken over by unauthorized persons, make sure the "Anonymous viewer login" button IS NOT checked/selected.

Buttons: Apply, Cancel

【User Management】 The system has automatically created ten user accounts.

To set up an user account:

1. Highlight a user account and its information will be displayed in the field below the account list.
2. Revise the account name, password and description. Select an authority level for the user account.

The default setting is Supervisor when using user1 account to log in.

- **Administrator:** The only difference between a supervisor and administrator is that a supervisor can edit an administrator’s account and password, but an administrator cannot edit the supervisor’s account and password. The supervisor and administrators all have unrestricted access to the Setting submenus and can determine the registration of all other users.

- **User:** A user can not only view the live view but also view/configure the below camera settings.

View	Configure
System Settings	
Network	Network > Protocol Settings
Date/Time	Date/Time > Date/Time Format Settings
Storage > Record to Local	Storage > Record to Local
Display and Overlay > Overlay Text Settings	Display and Overlay > Overlay Text Settings
Display and Overlay > Video Overlay Time Stamp Settings	Display and Overlay > Video Overlay Time Stamp Settings
System Maintenance > Language Settings	System Maintenance > Language Settings
System Information	System Information > Export Log
Camera Settings	
Streaming and Audio	-
Camera	-
Schedule	-
Image	-

- **Guest:** The lowest level of access, which only allows the user access to the live view page.
3. Select **Active** or **Disable** to active or disable the user account.
 4. Check the Enable micro SD Card box to allow the user to access the micro SD card playback function.
 5. Click the **Edit** button to save the changes.

Create : The button is only activated when the number of list is less than ten. Enter the account information and click the **Create** button, the new account will be listed in the account list.

Remove : Highlight an account and then click the **Remove** button to remove the highlighted account.

Edit : Highlight an account and enter the account information in the boxes below the account list. Click the **Edit** button and the account will be edited.

Cancel : Click the button to cancel the changes and return to the previous settings.

【Anonymous Settings】 Check the box to allow the unauthorized persons to log in the camera. Click **Apply** to apply the changes or **Cancel** to cancel the changes and return to the previous settings.

7.1.8 Black / White List

Use this page to specify IP addresses that are allowed / denied to access this camera. By default, any IP address can access the camera.

Note: The Allowed IP addresses only become relevant when the Denied items contain a **Network** or **Range**, and the supervisor wants to allow one or more IP addresses within that excluded range or network. In such a scenario, the user would enter the excluded range or network for the Denied items, and enter the exceptions for the Allowed items.

Black/White Management

Black/White List							
Permissi	Mask	IPv4 Address	IPv4 From	IPv4 End	IPv6 Address	IPv6 From	IPv6 End
deny			192.168.12.1	192.168.12.1			
allow			192.168.121.	192.168.121.2			

View 1 - 2 of 2

IP Type
Permission Type
Rule
IP Address From

- **IP Type:** Select IPv4 or IPv6 from the drop-down list.
- **Permission Type:** Select **Deny** to deny the IP addresses configured below from accessing the camera. The **Allow** option is only relevant if you've set up at least one Deny item configured with Network or Range network rule from the Rule drop-down list.
- **Rule:** Select a network rule and then fill in the IP information in the below boxes.
 - **Single:** Type a single IP address in the IP Address field below.
 - **Network:** Type the IP address and subnet mask in the field below.
 - **Range:** Type a range for the IP addresses.

Create : Set up the IP information and click the **Create** button, the created IP information will be listed in the Black/White list.

Remove : Highlight an item in the list and then click the **Remove** button to remove the highlighted item.

Edit : Highlight an item in the list and set up the IP information in the boxes below the Black/White list. Click the **Edit** button and the item will be edited.

Cancel : Click the button to cancel the changes and return to the previous settings.

7.2 Camera Settings

You can configure camera related settings, such as video / audio, region of interest and privacy mask.

7.2.1 Streaming and Audio

Basic / Advanced

System Settings

- Network
- Date/Time
- Storage
- Display and Overlay
- System Maintenance
- System Information
- User
- Black/White List

Camera Settings

- Streaming and Audio
- Profile
- Camera
- Schedule
- Image
- Serial Communication

Event Settings

- Event Wizard
- Event
- Notification

[Link to Smart Phone App](#)

Stream Settings

Streaming Preview

Stream 1

Enable Stream 1

Format

Resolution

Frame Rate

Bit Rate

Constant Bit Rate Bit/s

Variable Bit Rate

Stream 2

Enable Stream 2

Format

Resolution

Frame Rate

Bit Rate

Constant Bit Rate Bit/s

Variable Bit Rate

Region of Interest Settings

ROI Draw Tool

Area 1 Quality	<input type="text" value="10"/>	
Area 2 Quality	<input type="text" value="10"/>	
Area 3 Quality	<input type="text" value="10"/>	
Area 4 Quality	<input type="text" value="10"/>	
Area 5 Quality	<input type="text" value="10"/>	
Area 6 Quality	<input type="text" value="10"/>	
Area 7 Quality	<input type="text" value="10"/>	
Area 8 Quality	<input type="text" value="10"/>	

Privacy Mask Settings

Privacy Mask Draw Tool

Color

Level

Enable Area 1

Enable Area 2

Enable Area 3

Enable Area 4

Audio Settings

Enable Audio

Input Volume 0 10



【Stream Settings】 This IP camera can output three video streams simultaneously. For each of these streams, the user can set the compression format, resolution, bit rate, and frame rate individually. Stream 1 is always enabled for live view. To enable/disable Stream1 or Stream2, check the **Enable Stream 1 / Enable Stream 2** box.

Note: If you connect to the camera via the Internet and experience a delay (lag time) in the video feed, try to reduce the number of streams and the quality and resolution of the streams – but keep the frame rate at its maximum.

Format: Select the encoding format – H.264 or MJPEG.

Resolution: Select the most suitable resolution for your needs.

Frame Rate: This function can only be set up in the **Advanced** tab. Select from 1 to 30 fps.

Bit Rate: This function can only be set up in the **Advanced** tab. If required, select whether you want the stream to stream a **Constant Bit Rate** or a **Variable Bit Rate**, and set the values of whichever option you choose.

Click **Apply** to apply the changes or **Cancel** to cancel the changes and return to the previous settings.

【Region of Interest Settings】 This function can only be set up in the **Advanced** tab. The Region of Interest (ROI) function allows users to set up multiple regions within an image with better quality and less distortion than the rest of the image. You can also use this function together with the Digital Zoom function on the Live View window to get a better image result. Up to eight ROIs can be configured in this field.

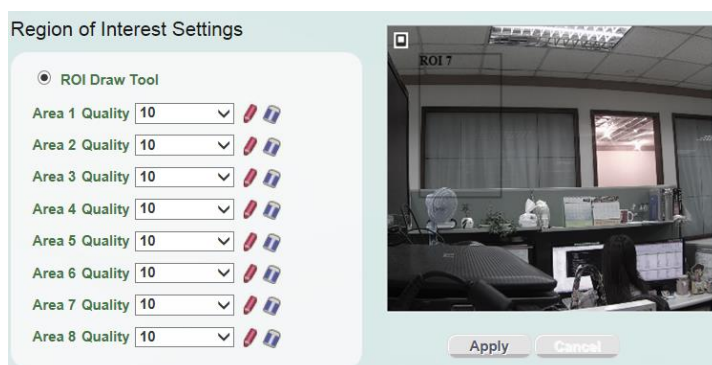

To set up an ROI region:

1. Enabled the **ROI Draw Tool** and click the **Draw** button .
2. On the left-side live image, move the cursor to the position where you want the ROI rectangle to start and then click. Move the cursor to the position (diagonally opposing corner) where you want the ROI rectangle to end and then click.
3. Select a quality value for the ROI from the Quality drop-down list.
4. Click the **Apply** button to apply the settings, or click the **Cancel** button to reset without saving the settings.

【Privacy Mask Settings】 This function can only be set **up in** the **Advanced** tab. The Privacy Mask can block out sensitive areas from view, covering the areas with colored or black and white boxes in both live view and recorded clips. This feature is useful when users' don't want the sensitive information visible. Up to four Privacy Masks can be configured.

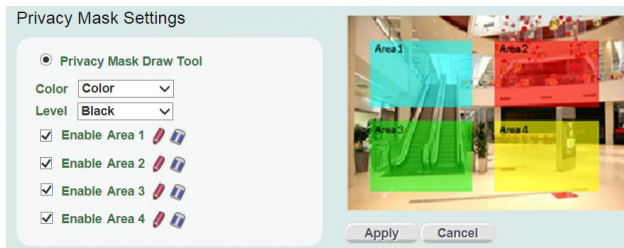

To set up a Privacy Mask:

1. Enabled the **Privacy Mask Draw Tool**.
2. From the Color drop-down list, select **Color** to make the masks appear as colored rectangles on the screen; or select **B/W** to make the masks appear as gray rectangles on the screen.
3. Select a color if you select **Color** from the color drop-down list. Select a level of grayness if you select B/W from the color drop-down list.
4. Check the **Enable** box to enable the configured privacy mask.
5. Click the **Draw** button  and move the cursor on the left-side live image.
6. Move the cursor to the position where you want the mask rectangle to start and then click. Move the cursor to the position (diagonally opposing corner) where you want the mask rectangle to end and then click.
7. Click the **Apply** button to apply the settings, or click the **Cancel** button to reset without saving the settings.

【Audio Settings】 The camera can transmit audio to your computer if you have connected an external microphone / line-in audio device to its audio Input. Check the **Enable Audio** box to enable the camera's audio input function and then adjust the audio input volume. Note that the camera provides the line-in / out terminal I / O, therefore, microphones / speakers with an (built-in) amplifier and external power supply are required.

Click **Apply** to apply the changes or **Cancel** to cancel the changes and return to the previous settings.

7.2.2 Profile

The Profile Settings is designed with four camera modes, which can be applied in various scenes to enhance image quality. You can apply different camera modes to the daytime and nighttime.

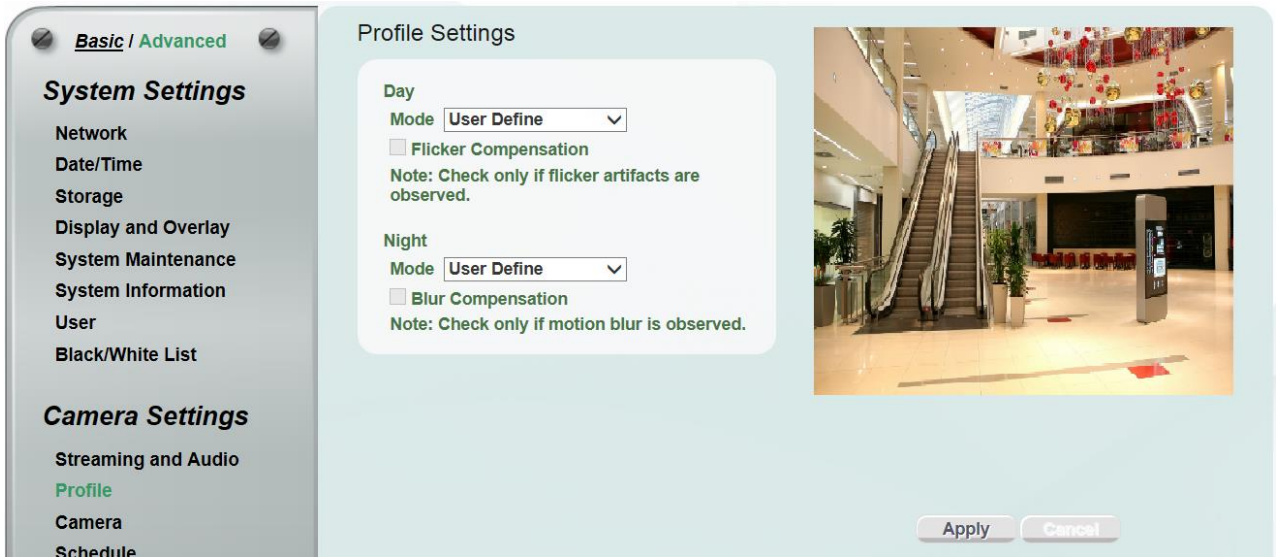

【Day Mode】 Select a camera mode and then click the **Apply** button to save the settings.

- **Vivid:** Select Vivid mode to have images with optimized contrast ratio. You can further configure the camera settings on the Camera setup page if required. Note that selecting the Vivid mode will lock (grayed-out) some Camera Settings on the Camera setup page such as **Exposure Settings (AE), Noise Reduction Settings and Monitor Settings.**
- **Standard:** Select Standard mode to have images with system configured settings. You can further configure the camera settings on the Camera setup page if required. Note that selecting the Standard mode will lock (grayed-out) some Camera Settings on the Camera setup page such as **Exposure Settings (AE), Noise Reduction Settings and Monitor Settings.**
- **More Detail:** Select More Detail mode to enhance the dark parts of the images. You can further configure the camera settings on the Camera setup page if required. Note that selecting the More Detail mode will lock (grayed-out) some Camera Settings on the Camera setup page such as **Exposure Settings (AE), Noise Reduction Settings and Monitor Settings.**
- **User Define:** Select User Define mode to customize the camera settings. You can configure all the camera settings on the Camera setup page.

Flicker Compensation: Check the box to enable the Flicker Compensation function. Please enable this function only if flicker artifacts are observed.

【Night Mode】 Select a camera mode and then click the **Apply** button to save the settings.

- **Vivid:** Select Vivid mode to have images with optimized contrast ratio. You can further configure the camera settings on the Camera setup page if required. Note that selecting the Vivid mode will lock (grayed-out) some Camera Settings on the Camera setup page such as **Exposure Settings (AE), Noise Reduction Settings and Monitor Settings.**
- **Standard:** Select Standard mode to have images with system configured settings. You can further configure the camera settings on the Camera setup page if required. Note that selecting the Standard mode will lock (grayed-out) some Camera Settings on the Camera setup page such as **Exposure Settings (AE), Noise Reduction Settings and Monitor Settings.**
- **More Detail:** Select More Detail mode to enhance the dark parts of the images. You can further configure the camera settings on the Camera setup page if required. Note that selecting the More Detail mode will lock (grayed-out) some Camera Settings on the Camera setup page such as **Exposure Settings (AE), Noise Reduction Settings and Monitor Settings.**
- **User Define:** Select User Define mode to customize the camera settings. You can configure all the camera settings on the Camera setup page.

Blur Compensation: Check the box to enable the Blur Compensation function. Please enable this function only if motion blur is observed.

7.2.3 Camera

【Day/Night Settings】

- **Mode:** Select a mode from the drop-down list.
 - **Auto:** Select to let the camera automatically switch to Night mode (black and white images with IR LED on) when the light levels fall to a specified level, and back to Day mode (color images) when the light levels rise to a specified level.
 - **Day:** Select to keep the camera in Day mode (color images with IR LED off), even in nighttime.
 - **Night:** Select to keep the camera in Night mode (black and white images with IR LED on), even in daytime.
 - **Schedule:** Select to let the camera to switch to Day mode or Night mode (IR LED on) based on the day and night schedule settings (see 7.2.3 *Schedule*).

- **Auto mode without IR LED:** Select to let the camera automatically switch to Night mode (black and white images with IR LED off) when the light levels fall to a specified level, and back to Day mode (color) when the light levels rise to a specified level.
- **Night mode without IR LED:** Select to keep the camera in Night mode (black and white images with IR LED off), even in daytime.
- **Schedule without IR LED:** Select to let the camera to switch to Day mode or Night mode (IR LED off) based on the day and night schedule settings (see 7.2.3 *Schedule*).
- **D/N Level:** This function can only be activated if you select **Auto / Auto mode without IR LED** mode in the Day/Night Settings field. Adjust the level (0 - 46 lux) for the camera to switch from Day mode to Night mode based on the light level detected by the Light Sensor. Click **Apply** to apply the changes or **Cancel** to cancel the changes and return to the previous settings.

Day Profile / Night Profile: Select **Day Profile** to configure the following settings for daytime and select **Night Profile** to configure the following settings for nighttime. Click the **Apply** button to save the settings.

Note: Some settings in the Exposure Settings / Features may be grayed-out. To configure all the settings, select **User Define** from the Day Mode / Night Mode drop-down list (see 7.2.2 *Profile*).

【Lens Settings】 Click **Apply** to apply the changes or **Cancel** to cancel the changes and return to the previous settings.

- **Focus Mode:** Select **Manual** to manually adjust the focus or select **Auto** to enable the Focus button on the live view window (see 5.4 *Live View Window*). Note that if you select **Auto**, the camera will automatically adjust focus every time when you click the zoom in / out button on the Live View window.

【Exposure Settings】 This function can only be set up in the **Advanced** tab and can only be activated when you select **User Define** from the Day Mode / Night Mode drop-down list (see 7.2.2 *Profile*). This setting is used to adapt to the amount or type of light used by the camera. Click **Apply** to apply the changes or **Cancel** to cancel the changes and return to the previous settings.

- **Mode:** Select a mode from the drop-down list.
 - **Auto:** Selecting Auto for the camera to automatically adjust the Shutter based on the measured light level.
 - **ALC (Shutter Priority):** Selecting ALC (Automatic Light Control) allows the camera circuitry to either take bright spots more into consideration (peak), bringing out detail in bright areas, or less into consideration (average) bringing out detail in shadows.
 - **Manual:** Select this option to manually set up the IRIS, Shutter (Manual) and AGC (Manual) values.

- **IRIS:** This function is only activated if you select **Manual** in the Mode field.
- **Shutter (Manual):** The function is only activated if you select **ALC** or **Manual** in the Mode field. If enabled, this setting lets you set the shutter speed yourself (measured in fractions of a second).
- **AGC (Manual):** The function is only activated if you select **Manual** in the Mode field. Set the Auto Gain Control limit here. The lower the AGC level, the lower the video signal and the noise.
- **Slow Shutter:** The function is only activated if you select **Auto** in the Mode field.
- **AGC:** The function is only activated if you select **Auto** or **ALC** in the Mode field. Set the Auto Gain Control limit here. The lower the AGC level, the lower the video signal and the noise.
- **Flickerless:** The function is only activated if you select **Auto** in the Mode field. Choose between OFF, 50HZ or 60HZ.

【Backlight Compensation Settings】 Backlight Compensation Settings is used to make the subject appear clearer when it is set against a bright background. Click **Apply** to apply the changes or **Cancel** to cancel the changes and return to the previous settings.

OFF: Select to switch Back Light Compensation functions off.

ON (BLC): This option is useful when the background of the subject is very bright and the subject itself is dark. The BLC will measure the light of the image center and the lens iris will automatically set for optimal image quality.

BLC Edit Mode: Click the **Enable** button, the BLC grids appear on the image. Click on the grids to enable / disable the BLC function. The selected grids (in green) will be applied with the BLC function.



【Features】 This function can only be set up in the **Advanced** tab. Click **Apply** to apply the changes or **Cancel** to cancel the changes and return to the previous settings.

- **Noise Reduction (NR):** This limits the amount of digital “video noise” that is usually found in any video stream, and helps to reduce file size. Select **Manual /Auto** to enable / disable the Noise Reduction function. Slide the Level bar to set up the level. The higher the level, the more the reduction.

2D DNR: Select **Manual** to enable the 2D DNR function and use the slide bar to set up the level. The greater the value, the more the reduction. Select **Auto** for the system to automatically adjust to the optimal 2D DNR value.

Level: Slide the bar to set up 2D DNR level.

3D DNR: Select **Manual** to enable the 3D DNR function and use the slide bar to set up the level. The greater the value, the more the reduction. Select **Auto** for the system to automatically adjust to the optimal 3D DNR value. You can further set up the following two settings. You can reach optimal results once two settings are balanced.

Strength: The greater the value, the greater the strength is, the more the reduction, and the lower the image sharpness.

Stabilizer: The greater the value, the greater the stabilizer is, the more the reduction, and the streaking phenomenon appeared.

- **Wide Dynamic Range (WDR):** The WDR function provides clearer images when both of the very bright and dark areas simultaneously appear on the camera view. There are three value options: OFF, ON and Auto. Note that when WDR is ON, some parts of the image may appear solarized. This is normal for WDR, and is not a camera malfunction.
- **Black Level:** Slide the Level bar to set up the level (0 – 46).
- **Monitor Type:** Users can use this field to optimize video quality of the monitor. Choose Vivid, Standard, or Neutral from the drop down list.

7.2.4 Schedule

The Schedule setup page is designed for users to configure the daytime and nighttime of each day. The Schedule setting is only functional if you select **Schedule** from the D / N Mode drop-down list on the Camera setup page.

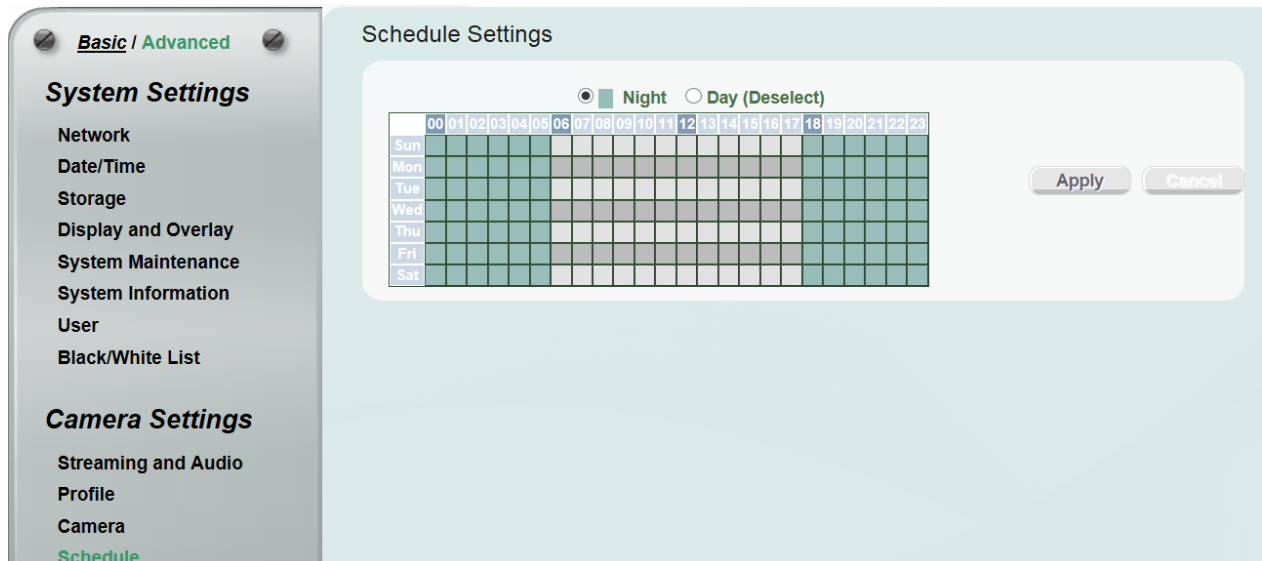

Select **Night** and then move the cursor on the desired time square, click and drag the cursor over the time squares to configure them to the Night mode (green color). Select **Day** and then move the cursor on the desired time square, click on the time squares to configure them to the Day mode (gray color).

Click **Apply** to apply the changes or **Cancel** to cancel the changes and return to the previous settings.

7.2.5 Image

This function can only be set up in the **Advanced** tab.

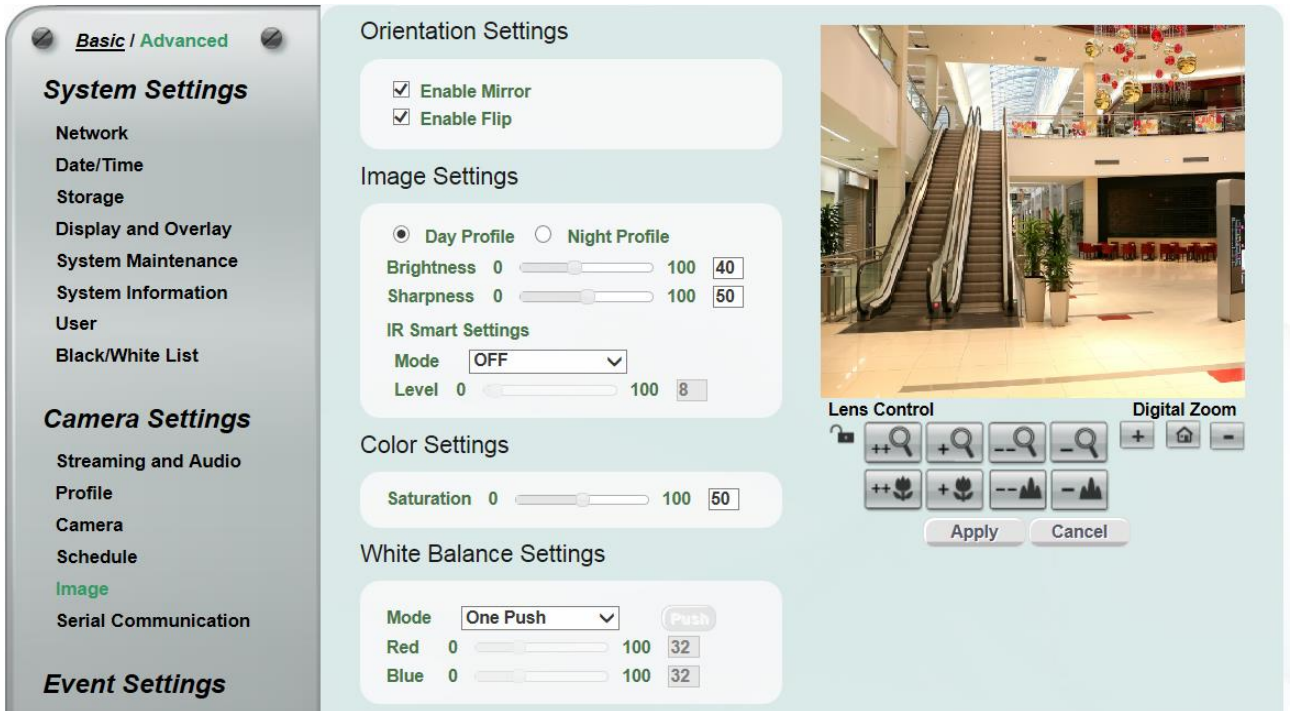

【Orientation Settings】

- **Enable Mirror:** Check the box to enable the mirror function. The image will be rotated horizontally around a vertical axis.
- **Enable Flip:** Check the box to enable the flip function. The image will be rotated vertically around a horizontal axis.

【Image Settings】

- Select **Day Profile** or **Night Profile**
- Configure the **Brightness** and **Sharpness** by using the level bars
- **IR Smart Settings:** Select **OFF** or **ON** mode. Use the level bar to adjust the level.

【Color Settings】 Slide the bar to adjust the **Saturation**.

【White Balance Settings】 Select a mode that delivers the best image quality for the camera’s light environment.

- **Auto:** Select to let the camera automatically adjust the White Balance. In the Auto mode the camera computes the white balance value output using color information from the entire screen. It outputs the proper value using the color temperature radiating from a black subject based on a range of value from 3000 to 7500K.
- **Manual:** Select to adjust the **Red** and **Blue** values below this field.
- **One Push:** Select to enable the **Push** button Push next to the Mode drop-down field. This will allow you to force the camera to readjust the white balance every time you push the **Push** button. The lens will hold the same focal position until the next trigger command is received. This function helps to prevent incorrect focusing in dark environments.

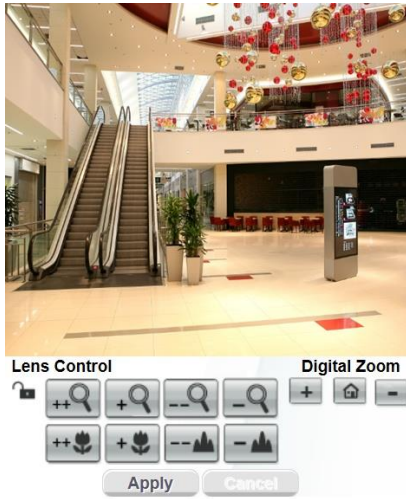

【Lens Control】

The Lens Control buttons can be hidden on the Live View window by disable the **Show Lens Control Buttons** function in the Live View Layout Settings (see 7.1.4 Display and Overlay).

■ **Zoom (Optical Zoom)**

To adjust zoom buttons, click the **Lock** icon to unlock first. Click the **Unlock** icon again to lock the zoom functions. Click and hold the buttons to continuously zoom in / out. Click the buttons to zoom in / out one step forward or backward.

Note:

1. If you select **Auto** from the Focus Mode drop-down list, the camera will automatically adjust focus every time you click the Zoom in / out buttons.

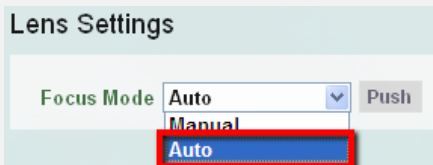

2. It is recommended to adjust camera zoom only when necessary. Adjusting camera zoom in Day mode or Night mode may cause an unfocused camera when it automatically switches from day to night mode or from night to day mode. When unfocused camera symptom occurs, click the **Focus** button for the camera to automatically adjust the focus or click the Focus buttons to fine tune camera focus.

■ **Focus**

To use the buttons to adjust focus, click and hold the buttons to continuously focus closer or farther. Click the buttons to focus one step closer or farther.

【Digital Zoom】

Click the zoom in / zoom out buttons to zoom in / out the camera live view. Click the Home button to go back to the home position.

7.2.6 Serial Communication

This function can only be set up in the **Advanced** tab.

The screenshot shows the 'Advanced' tab of the 'System Settings' menu. Under 'Serial Communication', there are two main sections: 'RS485 Setting' and 'Server Settings'. The 'RS485 Setting' section includes four dropdown menus: 'Baud Rate' (set to 38400), 'Data Bit' (set to 8), 'Stop Bit' (set to 1), and 'Parity' (set to None). There are 'Apply' and 'Cancel' buttons to the right of these settings. The 'Server Settings' section includes an 'Enable' checkbox (unchecked), and three input fields for 'IP Address', 'Username', and 'Password'. There are also 'Apply' and 'Cancel' buttons to the right of these fields.

【RS485 Setting】

Baud Rate: This field is to set the speed at which is used to transmit instruction or information through the RS485 port on the video encoder. There are six different speeds, 2400 / 4800 / 9600 / 19200 / 38400 / 57600.

Data Bit: This field is the data bit at which you will be transferring.

Stop Bit: This field is to set the stop bit for the RS485 connection. There are two different stop bits, 1 or 2.

Parity: This field is to select the parity level at which you will be connected. You can choose between **None**, **Odd**, or **Even** parity levels.

【Server Setting】

To set up server for data transmission, enter **IP Address**, **Username** and **Password** and check the **Enable** box. Click **Apply** to save your settings.

7.3 Event Settings

You can set up the Motion Detection event or Tampering Detection event to automatically notify the users when an event occurs. You can also set up a schedule to automatically record the videos when an event occurs.

7.3.1 Event Wizard

The Event Wizard allows users to easily configure the event settings. Follow the on-screen instructions to complete the event settings.

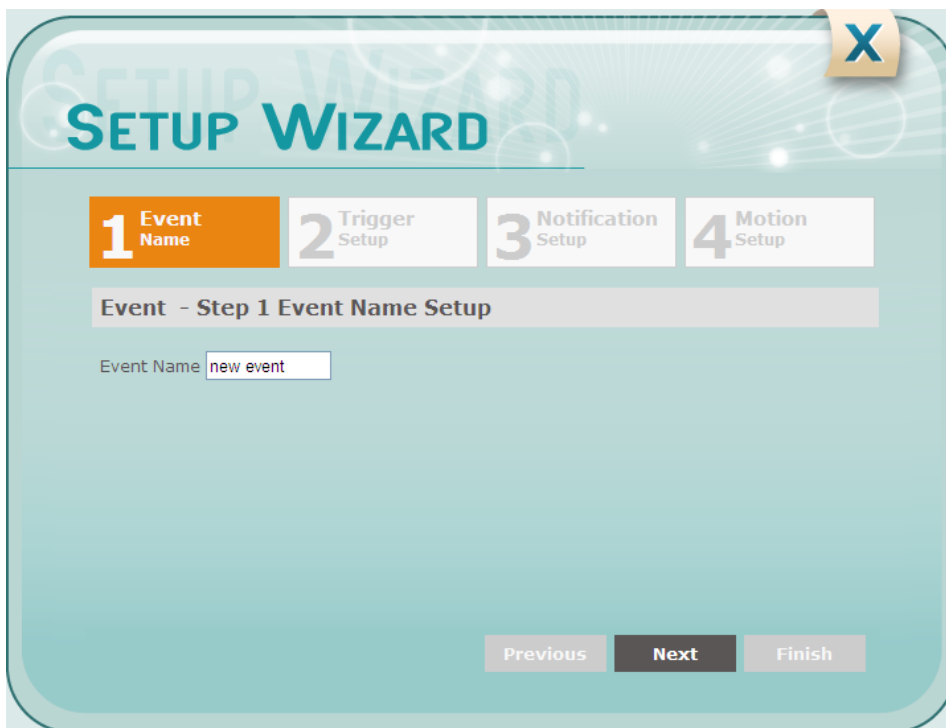

7.3.2 Event

This function can only be set up in the **Advanced** tab. Except the Event Wizard, you can also configure the event settings along with the Recording Schedule on this page.

Basic / Advanced

System Settings

- Network
- Date/Time
- Storage
- Display and Overlay
- System Maintenance
- System Information
- User
- Black/White List

Camera Settings

- Streaming and Audio Profile
- Camera
- Schedule
- Image
- Serial Communication

Event Settings

- Event Wizard
- Event**
- Notification

[Link to Smart Phone App](#)

Event Management

Name	Type	Notification	Enable
new event	Alarm Input	FTP,SD,syslog	Yes
new event1	Motion Detectic	syslog	Yes
new event2	Tampering Det	email	Yes
new event3	Motion Detectic	syslog	Yes

View 1 - 4 of 4

Event Name:

Event Trigger Type: Alarm Input Motion Area1

Enable This event This Trigger Type has already been enabled

Enable Re-trigger miniman interval between triggers second

Enable Pre-trigger Buffer

Enable Post-trigger Buffer

Notification Over

Log

Trigger Alarm Output Duration Time second

Send Mail Notification

Upload to FTP

Record to micro SD Card

Network Alarm

Event Trigger Settings

Input 1 Trigger Type: Normal Open

Output 1 Contact Type: Normal Open

Tamper Detection Settings

Tamper Duration Time second

Trigger Options Settings

Pre-trigger Buffer second

Post-trigger Buffer second

Schedule Settings

Event Schedule Event + Schedule Deselect

	00	01	02	03	04	05	06	07	08	09	10	11	12	13	14	15	16	17	18	19	20	21	22	23
Sun																								
Mon																								
Tue																								
Wed																								
Thu																								
Fri																								
Sat																								

Motion Settings

Area 1 ■ Enable

Sensitivity [Red] [Blue]

Area 2 ■ Enable

Sensitivity [Red] [Blue]

Area 3 ■ Enable

Sensitivity [Red] [Blue]

Area 4 ■ Enable

Sensitivity [Red] [Blue]

【Event Management】 You can set up the events such as Motion Detection or Tampering Detection to automatically notify the users when an event occurs.

Event Name: Type an event name.

- **Event Trigger Type:** Select an event for the to-be-specified-below reaction/s.
 - **Alarm Input:** Select this if you want a reaction trigger coming from any external, connected sensor to activate a to-be-specified-below reaction/s via the camera system. Make sure that a suitable device is actually connected to the alarm input relay.
 - **Manual Trigger:** Select this option if you want to manually trigger the alarm by clicking the **Trigger Event** button on the Live View Page.
 - **Motion Detection:** Select this option to trigger the to-be-specified-below reaction/s when motion events occur. You have to pre-configure the Motion Settings for this function to work.
 - **Schedule Recording:** Select this option if you want the Schedule Recording periods configured in the Schedule Settings to activate this event. In this scenario, a preconfigured event reaction like a log entry will list the start and end times of each period. Actual recording will only be triggered if the event is preconfigured to do so.
 - **Tampering Detection:** Select this option if you want the camera's tampering detection sensor to trigger the to-be-specified-below reaction/s. You can set up the tamper duration time in the Event Trigger Settings field below.
- **Enable This Event:** Check the box to activate the event. For Alarm Input, Manual Trigger, and Tampering Detection trigger types, multiple events can be created on the Event List but only one event can be enabled. For example, if you create three Alarm Input trigger events, only one event under this trigger type can be enabled. The option of **Enable This Event** for the rest of two Alarm Input events will be grayed out and display **"This Trigger Type has already been enabled."** To enable another event under the same type, uncheck to disable the event first and check the desired event.
- **Enable Re-trigger minimum interval between triggers second:** Check the box to set a minimum time after the event is triggered before the event can be triggered again.
- **Enable Pre-trigger Buffer:** Check the box if you want the Event reaction (as selected in the "Notification Over" field below) to be the activation of the video recording function, and if you want the recording to include the video feed from the time period (configurable in the Schedule Settings field) just before the Event trigger occurred.
- **Enable Post-trigger Buffer:** Check the box if you want the Event reaction (as selected in the Notification Over field) to be the activation of the video recording function, and if you want the recording to include the video feed from a time period (configurable in the Schedule Settings field) just after the Event trigger occurred.

Notification Over: Select the desired notification types from the following items.

- **Log:** Check the box if you want the camera to list the event’s details in its log if the event is triggered.
- **Trigger Alarm Output Duration Time** **second:** Check if you want the camera to relay the event reaction to a device attached to the alarm relay output wire and then set up the alarm output duration time.
- **Send Mail Notification:** Check the box if you want the camera to send an email text notification and one image file to the email address entered in the SMTP Settings field (see 7.3.3 *Notification*).
- **Upload to FTP:** Check the box if you want the camera to upload the recordings to the FTP server entered in the FTP Repository Settings (see 7.3.3 *Notification*).
- **Record to micro SD Card:** Check the box if you want the camera to start recording its video feed (when the event occurs) on an on-camera micro SD Card (if such a card has been inserted).

Note: The recording will only be as long as the combined Pre- and Post-trigger Buffers, so make sure you enable at least one of these buffers, especially the Post-trigger Buffer.

- **Network Alarm:** Check the box if you want the camera to send a network alarm signal (when the event occurs) to the CMS servers. Note that you have to configure the Network Alarm Settings for this function to work (see 7.3.3 *Notification*).

Create : Set up the Event information and click the **Create** button, the created Event information will be listed in the Event List.

Remove : Highlight an item in the Event List and then click the **Remove** button to remove the highlighted item.

Edit : Highlight an item in the Event List and edit the Event information on the left-side. Click the **Edit** button and the item will be edited.

Cancel : Click the button to cancel the changes and return to the previous settings.

【Event Trigger Settings】

- **Input 1 Trigger Type:** Select **Normal Open** or **Normal Close** from the drop-down list.
- **Output 1 Contact Type:** Select **Normal Open** or **Normal Close** from the drop-down list.

【Tamper Detection Settings】

- **Tamper Duration Time:** Set up a duration time between 10 and 120 seconds.

【Trigger Options Settings】

- **Pre-trigger Buffer** **second:** Select the duration for the buffer. This will determine the amount of footage (length of time) before the event trigger moment that will be included in an event-triggered video recording, if that buffer and video recording has been enabled in the Event Management field.
- **Post-trigger Buffer** **second:** Select the duration for the buffer. This will determine the amount of footage (length of time) after the event trigger moment that will be included in an event-triggered video recording, if that buffer and video recording has been enabled in the Event Management field.

Click **Apply** to apply the changes or **Cancel** to cancel the changes and return to the previous settings.

【**Schedule Settings**】 Users can configure the recording schedule here. Select the desired recording types among the options below. Click and drag the cursor on the time block, which will be applied with the selected recording type.

- **Event (Red):** Select for the camera to activate all the Event Recording set up in the Event Management field (Event Trigger Type), except the Schedule Recording.
- **Schedule (Green):** Select for the camera to activate only the Schedule Recording set up in the Event Management field (Event Trigger Type).
- **Event + Schedule (Yellow):** Select for the camera to active both of the configured Event and Schedule Recordings.
- **Deselect (Grey):** Select for the camera to stop recording.

Click **Apply** to apply the changes or **Cancel** to cancel the changes and return to the previous settings.

【**Motion Settings**】 Use this page to configure up to four areas in which motion will be detected.

When a motion is detected by the camera, the motion detection icon  will appear at the top right corner on the Live View Window to alert the user. This function can also be linked with correctly configured Events to trigger Event reactions like the activation of video recording periods, snapshots, etc.

To set up the Motion area:

1. Check the **Enable** box to enable the selected area.
2. Select a sensitivity value of the motion detection sensor function.
3. Click the **Draw** button  and move the cursor on the left-side live image.
4. Move the cursor to the position where you want the motion rectangle to start and then click. Move the cursor to the position (diagonally opposing corner) where you want the motion rectangle to end and then click.
5. Click the **Apply** button to apply the settings, or click the **Cancel** button to reset without saving the settings.

7.3.3 Notification

This function can only be set up in the **Advanced** tab.

Basic / **Advanced**

System Settings

- Network
- Date/Time
- Storage
- Display and Overlay
- System Maintenance
- System Information
- User
- Black/White List

Camera Settings

- Streaming and Audio Profile
- Camera
- Schedule
- Image
- Serial Communication

Event Settings

- Event Wizard
- Event
- Notification

[Link to Smart Phone App](#)

SMTP (Email) Settings

SMTP Server

SMTP Port

Authentication

Username

Password

Receiver Address Apply Cancel

(use ; to separate addresses)

Sender Address

Attach Image

SSL Connection

Send Test Email

FTP Repository Settings

FTP Server

FTP Port

Recording Path

Username Apply Cancel

Password

PASV Mode

Test FTP Server

SNMP Settings

Enable SNMP v1/v2/v2c

Read-Only Community

Read-Write Community

Trap Community

Trap Address

Enable SMNP v3

Read-Only Username

Read-Only Auth. Method Apply Cancel

Read-Only Auth. Key

Read-Only Privacy Method

Read-Only Privacy Key

Read-Write Username

Read-Write Auth. Method

Read-Write Auth. Key

Read-Write Privacy Method

Read-Write Privacy Key

Network Alarm Settings

Protocol Port No

Unique ID Server 1

Server 2 Server 3

Apply Cancel

【SMTP (Email) Settings】 This area is for configuring the mail server that is used to send e-mail text notifications and one image file from the camera to predefined addresses via SMTP. Note that to enable e-mail notification function, you have to check the **Send Mail Notification** box in the Event Management field (see 7.3.2 *Event*).



- **SMTP Server:** Enter the IP address or the host name of the SMTP server used to send e-mails.
- **SMTP Port:** Enter the port number for SMTP. The default is 25.
- **Authentication:** Check the box if the SMTP server requires authentication (user / password).
- **Username:** Input the user’s login ID if the SMTP server requires authentication.
- **Password:** Input the user’s login password if the SMTP server requires authentication.
- **Receiver Address:** Input the e-mail addresses for receiving an e-mail message when events occur. Please use “;” to separate multiple addresses.
- **Sender Address:** Input the sender’s e-mail address, so that the receiver can recognize the sender when an event message is received.
 - **Attach Image:** Check the box if you want to attach an image when events occur.
 - **SSL Connection:** Check the box to enable the SSL function. Enable this function means you can access the camera through the SSL protocol that provides communication security over the Internet.
- **Send Test Email:** Click the **Test** button to send a testing email to the assigned address.

Click **Apply** to apply the changes or **Cancel** to cancel the changes and return to the previous settings.

【FTP Repository Settings】 This area is for configuring the FTP server that is used to send alarm recordings from the camera to the preconfigured FTP server. Note that to enable uploading recordings to the FTP server function, you have to check the **Upload to FTP** box in the Event Management field (see 7.3.2 *Event*).

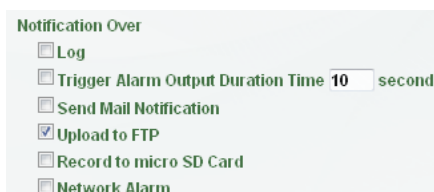

- **FTP Server:** Enter the IP address or the host name of the FTP server.
- **FTP Port:** Enter the port number for the FTP server. Default is 21.
- **Recording Path:** Assign the recording path.
- **Username:** Set FTP User’s name.
- **Password:** Set FTP password.
- **PASV mode:** Check the box to enable Passive mode. Passive mode is normally enabled. If a connection cannot be established, uncheck "PASV Mode".

- **Test FTP Server:** Click the **Test** button to send a testing file to the assigned FTP server.

Click **Apply** to apply the changes or **Cancel** to cancel the changes and return to the previous settings.

Note: If the camera lost connection to the FTP server, the recordings will be automatically uploaded to the micro SD card on the camera. Once the connection between FTP server and camera has re-established, the camera will resume uploading recordings to the FTP server. However, the recordings uploaded to the micro SD card during the disconnection period will not be uploaded to the FTP server.

【SNMP Settings】 The default values for SNMP v1/v2/v2c and SNMP v3 are already filled in. Click either of the Enable buttons to enable either of the two. Make your changes as desired. Click on the **Trap Address** field to enter the digits, if required.

Click **Apply** to apply the changes or **Cancel** to cancel the changes and return to the previous settings.

【Network Alarm Settings】 This function works with EverFocus CMS software. The camera can send a network alarm signal (when the event occurs) to the CMS servers. To establish the connection between the camera and CMS servers, the protocol and port number should match with each other. For more details, please refer to the CMS user’s manual. Note that to enable the Network Alarm function, you have to check the **Network Alarm** box in the Event Management field (see *7.3.2 Event*).

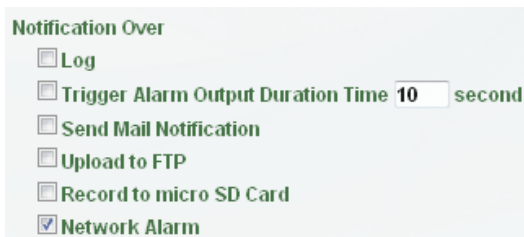

Click **Apply** to apply the changes or **Cancel** to cancel the changes and return to the previous settings.

7.4 Link to Smart Phone App

You can access camera live view or take a snapshot via your smart phone. This page is designed for users to download the mobile app to your mobile phone by scanning the QR code.

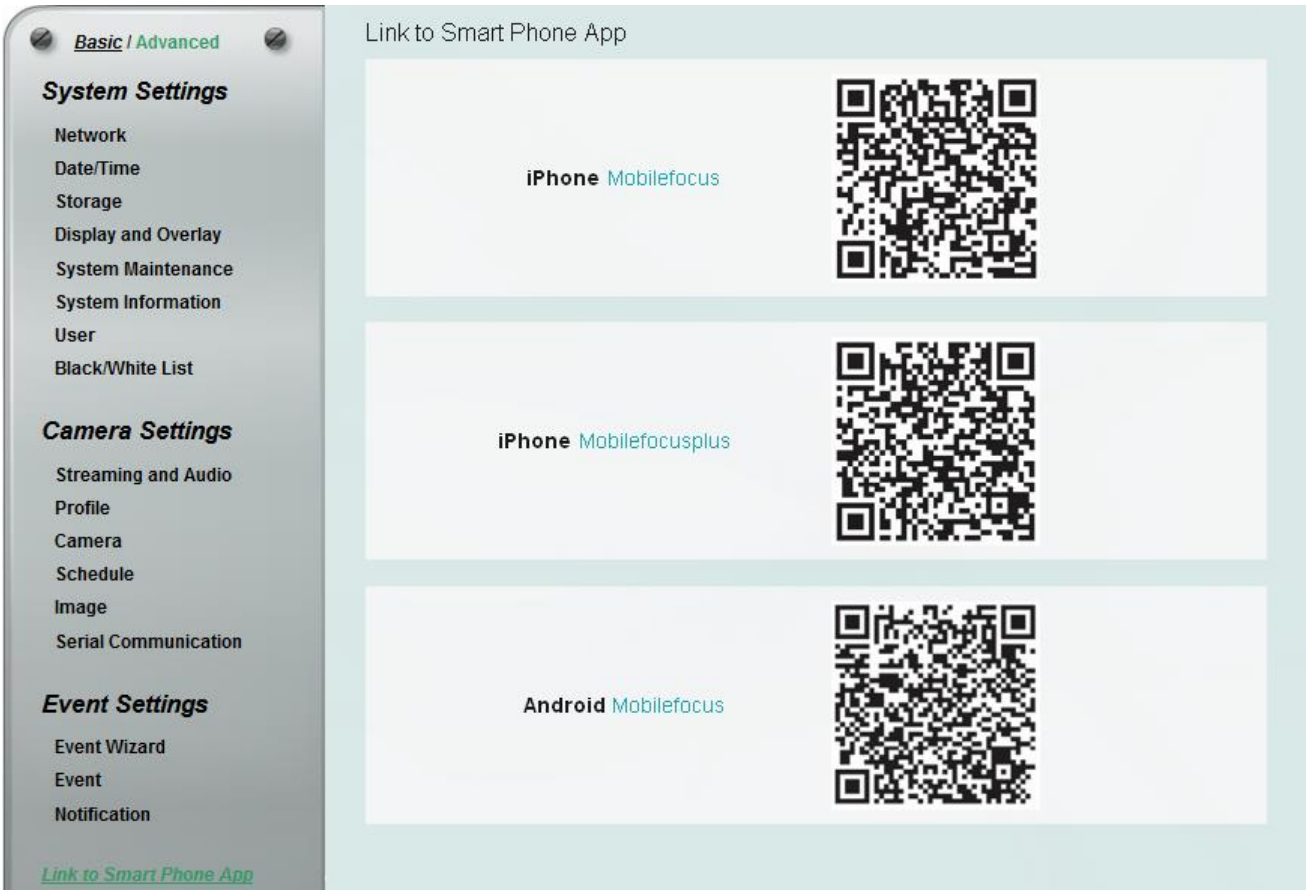

MobileFocus for iPhone



MobileFocusPlus for iPhone



MobileFocus for Android-based smart phone

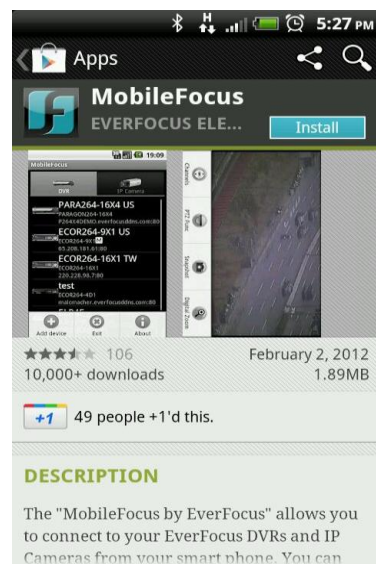

8. Upgrading Firmware Using IP Utility

You can upgrade the Firmware using the **IP Utility** software included in the software CD or from the Website of EverFocus (click [here](#) to download).

1. Save **IP Utility Setup AutoRun.exe**  in your computer. Double click the .exe file and follow the on-screen instructions. Check **Run IPUtility.exe** and click the **Finish** button, the IP Utility will be launched to search the IP devices connected in the same LAN automatically.

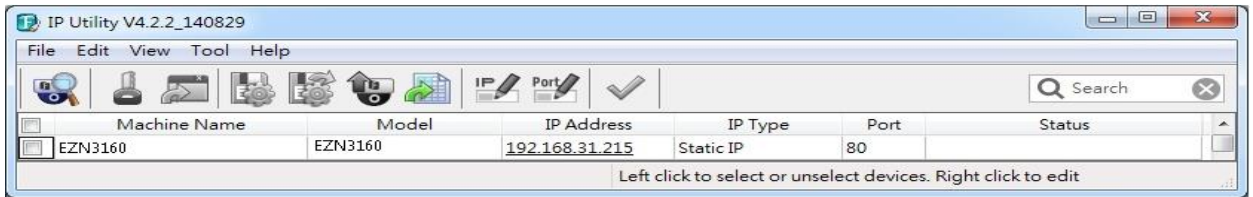

2. Log in the camera by checking the desired model and then click the **Log in**  icon. The Log in dialog box appears.

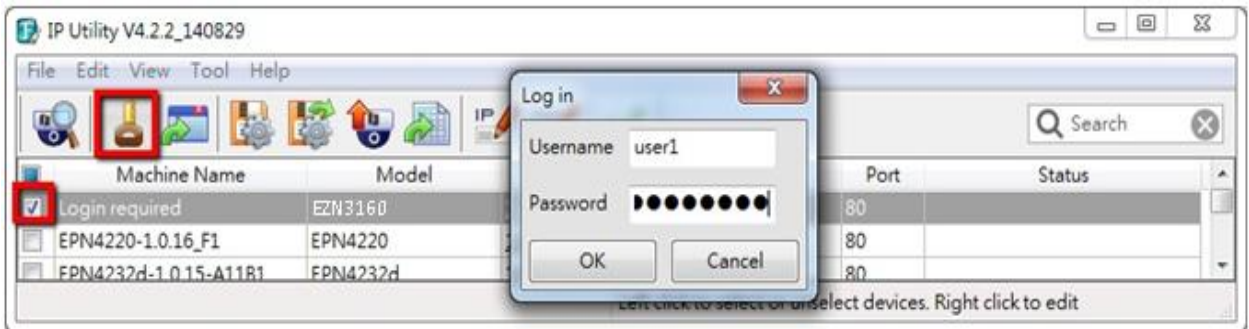

3. Type the Username and Password. Click the **OK** button, the **Login** status displays.

Machine Name	Model	IP Address	IP Type	Port	Status
<input checked="" type="checkbox"/> EZN3160	EZN3160	192.168.31.215	Static IP	80	Login

Note:

1. The default user ID is user1 and the default password is 11111111.
2. If you select more than one camera that has the same user ID / password, you will be able to log in several cameras at once.
3. Up to 10 cameras can be simultaneously upgraded to the latest firmware. If you connect the cameras to a PoE switch, please make sure the Power Consumption of the PoE switch is sufficient.

- Click the **Upgrade Firmware** button , a browsing window appears.

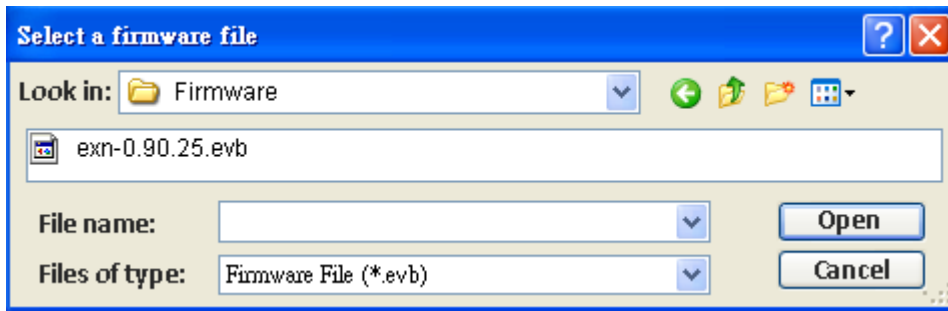

- Select the **firmware file (.evb)** and then click **Open**. The IPU will automatically upgrade the firmware. The camera will reboot once the upgrade process is complete.

	Machine Name	Model	IP Address	IP Type	Port	Status
<input checked="" type="checkbox"/>	EZN3160	EZN3160	192.168.31.215	Static IP	80	Login

9. Specifications

Model	EZN3160		EZN3260	
Camera				
Image Sensor	1/2.8" full HD progressive scan CMOS sensor			
Megapixel	1.3MP		2MP	
Min. Illumination	Color: 0.1 Lux at F1.3 B/W: 0.02 Lux at F1.3 0 Lux at F1.3 (IR LEDs on)			
Electronic Shutter	1/7.5 ~ 1/15,000sec			
Scanning System	60Hz (NTSC) / 50Hz (PAL)			
WDR	Yes			
BLC	Yes			
Gain Control	Yes			
White Balance	Yes			
Lens				
Lens Type	Varifocal, Auto Focus			
Focal Lens	3.3 ~ 10mm			
Aperture Ratio	F1.3			
P-Iris	Yes			
Day / Night	Yes (with removable IR-cut filter)			
Angle of View	Horizontal 108.2° ~ 35.4°, Vertical 56.2° ~ 19.8°, Diagonal 129.3° ~ 40.5°			
IR Distance	40m / 131ft.			
IR LED Quantity	44			
Video				
Video Compression	H.264 / MJPEG			
Resolution	NTSC	1920 x 1080 (for EZN3260), 1280 x 1024, 1280 x 720 (for EZN3260), 1024 x 768, 720 x 480, 704 x 480, 640 x 480, 352 x 240, 320 x 240		
	PAL	1920 x 1080 (for EZN3260), 1280 x 1024, 1280 x 720 (for EZN3260), 1024 x 768, 720 x 576, 704 x 576, 640 x 480, 352 x 288, 320 x 240		
Frame Rate	30fps at 1280 x 1024		30fps at 1920 x 1080	
Audio				
Audio Streaming	Two-way audio			
Audio Compression	G.711			

Network		
Interface	10BASE-T / 100BASE-TX auto-negotiation, RJ-45 socket Support MDI / MDI-X auto crossover function	
Supported Protocols	TCP / IP, IPV6, UDP, ICMP, DHCP, NTP, DNS, DDNS, SMTP, SNMP, FTP, HTTP, HTTPS, PPPoE, UPnP, Bonjour, RTP, RTSP, RTCP, UDP, IGMP, SSL, ICMP, ARP, ONVIF, QoS	
Bandwidth Control	Min. 256 k Byte / sec adjustable	
Mechanical		
Camera Angle Adjustment	Pan	360°
	Tilt	90°
	Rotate	180°
Connector	Power	12VDC, PoE
	Ethernet	RJ-45
	Memory Card	One micro SD / SDHC card slot (up to 32GB)
Terminal Block	Audio In/Out	1 in 1 out
	Alarm	1 in 1 out triggered by intelligent event and external input
General		
Power Source	12VDC / PoE (IEEE802.3af Class 3)	
Max. Power Consumption	12VDC 9.1W (IR LEDs on) / PoE 9.436W (IR LEDs on)	
Operating Temperature	-40°C ~ 55°C / -40°F ~ 131°F (12VDC); -20°C ~ 55°C / -4°F ~ 131°F (PoE)	
Humidity	20% ~ 80% (no condensing)	
Safety	CE, FCC	
Weather-Resistant	IP68	
Vandal Proof	IK10 for metal casing	
Housing Material	Aluminum	
Dimensions (Φ x H) (Φ x H x L)	In line: 105.5 x 359.9mm / 4.15 x 14.17" Right angle: 105.5 x 145 x 312.7mm / 4.15 x 5.7 x 12.3"	
Weight	1.6kg / 3.53lb	
Language	Czech, Dutch, English, French, German, Japanese, Polish, Portuguese, Russian, Simplified Chinese, Spanish, Traditional Chinese	

10. Troubleshooting

Error messages pop up

A. When these error messages pop up, follow the steps below to fix the problem.



1. To enter the Registry Editor of your computer: Click **Start** and type “**regedit**” in the *Search Program and Files* field.

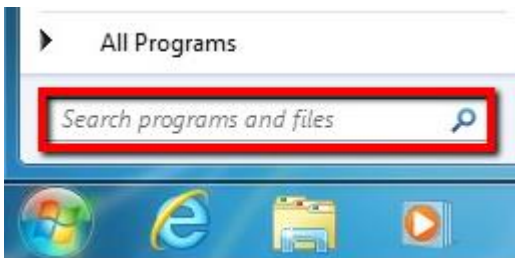

2. Click the **Enter** button, the Registry Editor window appears.

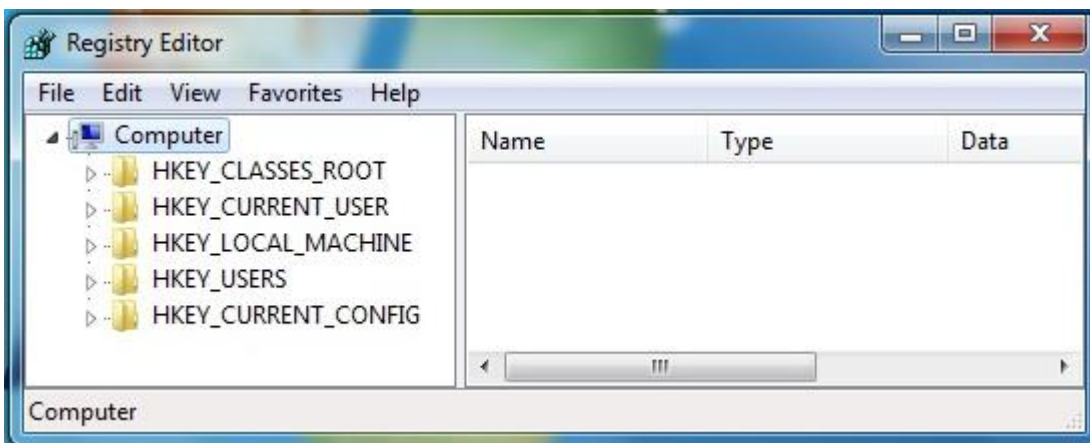

3. Find the **KeepAlive Timeout** Dword by following the path:

\HKEY_CURRENT_USER\Software\Microsoft\Windows\CurrentVersion\Internet Settings

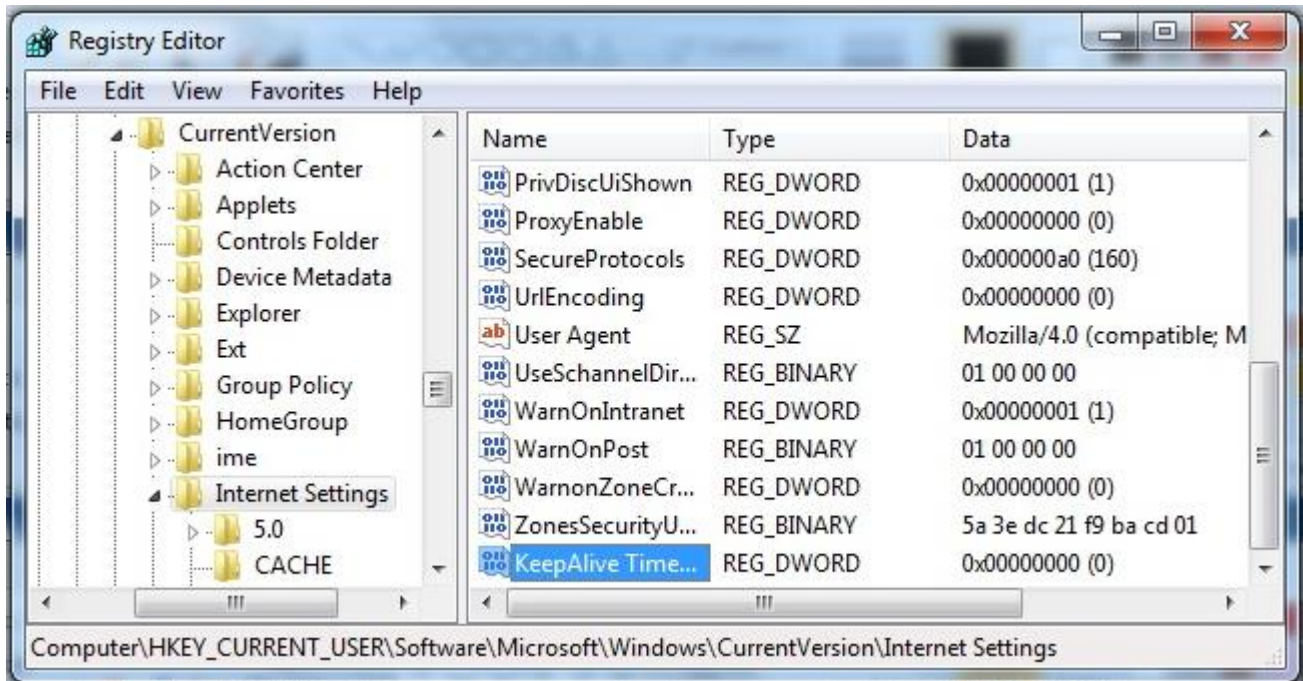

4. Double-click **KeepAlive Timeout** and this window appears.

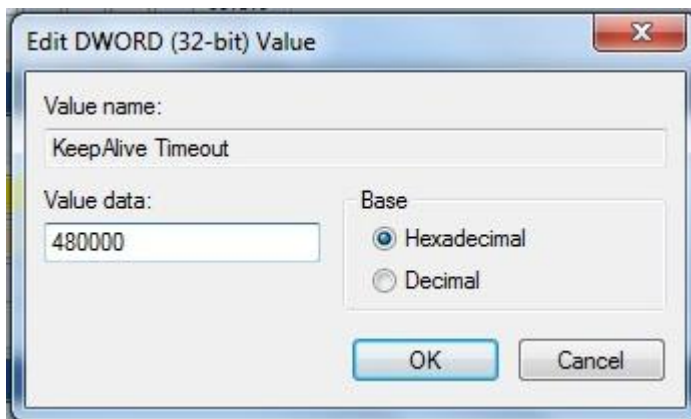

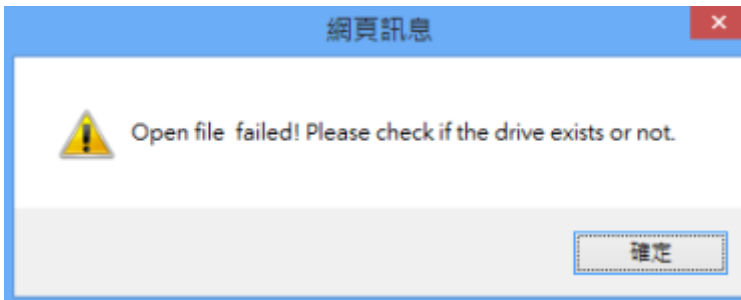

5. Change the Value data to **480000** and click **OK**.

B. Snapshot / Record error message.



For Microsoft IE10 and above users, you may have the above error message pop up when you click the

Snapshot  or **Record**  button on the Live View window. You can simply solve this problem by setting up your Microsoft Internet Explorer to **Run as administrator**.

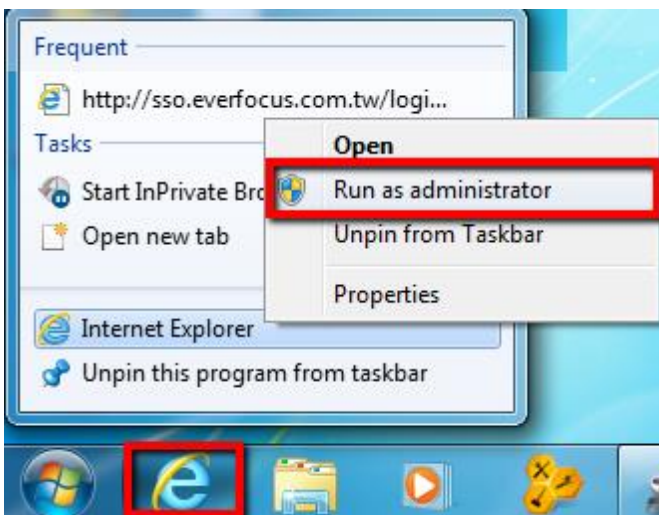

Low Frame Rate

If the frame rate is lower than expected, follow the steps below to fix the problem.

1. Reduce the number of applications running on your PC.
2. Limit the number of users that access camera live view.
3. Make sure you have sufficient bandwidth.
4. Lower the video resolution.
5. Lower the camera Bit Rate by configuring Constant Bit Rate or Variable Bit Rate (see 7.2.1 *Streaming and Audio*).

Appendix

A. Tested Card Brands

This IP Camera supports micro SD / SDHC card up to 32GB. The following brands of the micro SD cards have been tested by EverFocus and are recommended to work with EverFocus IP camera.

Brand	AData	Kingston	Samsung	SanDisk	Transcend
Card Capacity	32GB	32GB	32GB	32GB	32GB
Card Rate Level	Class 10	Class 10	Class 10	Class 10	Class 10

AData: Premier microSDHC/SDXC UHS-I Class10

Kingston: MicroSDXC UHS-I Class10 32GB

Samsung: MicroSDXC 32GB UHS-I

SanDisk: Ultra® microSDXC™ UHS-I card

Transcend: MicroSDXC Class 10 UHS-I memory card 300x

B. Enabling the Multicast Function

The Multicast Function is a technique for one-to-many communication over an IP infrastructure in a network that is designed to share IP camera loading and reduce network bandwidth. Note that for this function to work, the router / switch must support multicast function.

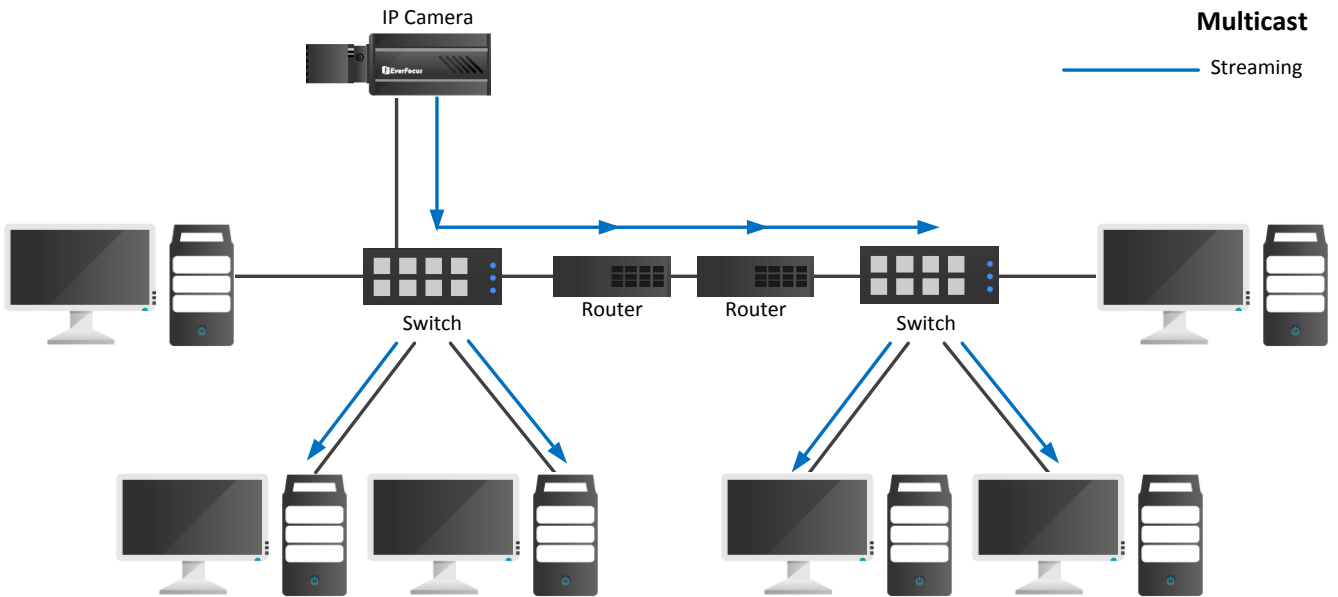

To enable the Multicast Function:

1. Complete the installation of the IP cameras, routers/ switches and computers (refer to diagram above).
2. Install VLC and Wireshark in your computer. Click [VLC](#) and [Wireshark](#) to download.
3. Access to the Web UI of the IP camera to enable the Multicast function. Click the **Apply** button to save the setting. (Advanced tab > Network> Multicast Settings> Enable Multicast)

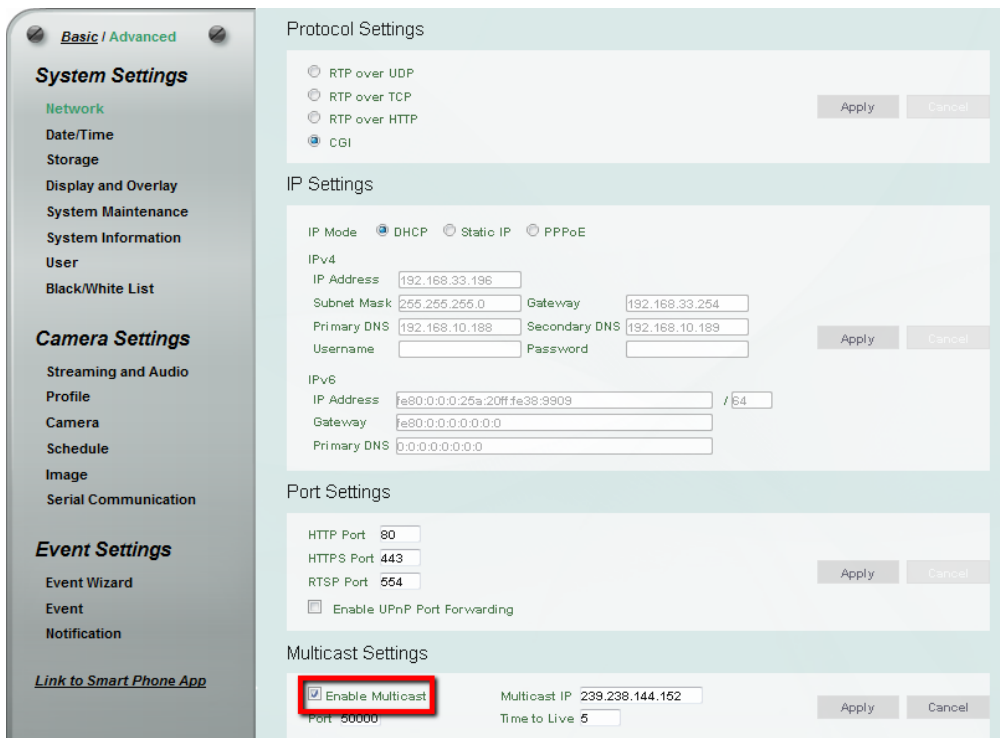

- Go to the setting page of the router/switch to enable the Multicast function.
Here we use a D-Link DIR655 router and EverFocus 24-port switch for example.

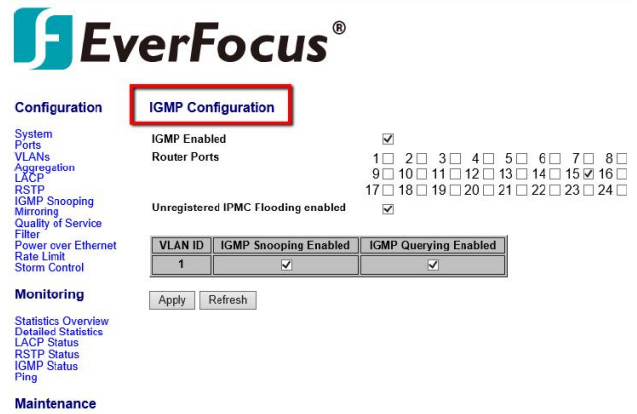

- The Multicast function setup is now complete.

EverFocus Electronics Corp.

EverFocus Taiwan:

12F-1, No.79, Sec. 1, Shin-Tai Wu Road,
Hsi-Chih, New Taipei City, Taiwan
TEL: +886 2 2698 2334
FAX: +886 2 2698 3943
www.everfocus.com.tw
marketing@everfocus.com.tw

EverFocus China - Beijing:

Room 609, Technology Trade Building,
Shangdi Information Industry Base,
Haidian District, Beijing 100085, China
TEL: +86 10 6297 3336~39
FAX: +86 10 6297 1423
www.everfocus.com.cn
marketing@everfocus.com.cn

EverFocus USA - California:

1801 Highland Avenue, Unit A, Duarte, CA 91010,
USA
TEL: +1 626 844 8888
FAX: +1 626 844 8838
www.everfocus.com
sales@everfocus.com

EverFocus Europe - Germany:

Albert-Einstein-Strasse 1, D-46446
Emmerich, Germany
TEL: +49 2822 93940
FAX: +49 2822 939495
www.everfocus.de
sales@everfocus.de

EverFocus China - Shenzhen:

4F, No. 2, D4 Building, Wan Yelong
Industrial Park, Tangtou Road, Shiyan,
Baoan, Shenzhen, Guangdong 518101, China
TEL: +86 755 2765 1313
FAX: +86 755 2765 0337
www.everfocus.com.cn
marketing@everfocus.com.cn

EverFocus Japan:

3F, Kuramochi, Building II
2-2-3 Koto-Bashi, Sumida-Ku,
Tokyo, 130-0022, Japan
TEL: +81-3-5625-8188
FAX: +81 3 5625 8189
www.everfocus.co.jp
info@everfocus.co.jp



Your EverFocus product is designed and manufactured with high quality materials and components which can be recycled and reused.
This symbol means that electrical and electronic equipment, at their end-of-life, should be disposed of separately from your household waste. Please, dispose of this equipment at your local community waste collection/recycling centre.
In the European Union there are separate collection systems for used electrical and electronic product. Please, help us to conserve the environment we live in!

Ihr EverFocus Produkt wurde entwickelt und hergestellt mit qualitativ hochwertigen Materialien und Komponenten, die recycelt und wieder verwendet werden können.
Dieses Symbol bedeutet, dass elektrische und elektronische Geräte am Ende ihrer Nutzungsdauer vom Hausmüll getrennt entsorgt werden sollen.
Bitte entsorgen Sie dieses Gerät bei Ihrer örtlichen kommunalen Sammelstelle oder im Recycling Centre.
Helfen Sie uns bitte, die Umwelt zu erhalten, in der wir leben!



P/N: 4605PZ3160B123A-Ver.C