

---

# INSTALLATION INSTRUCTIONS

---

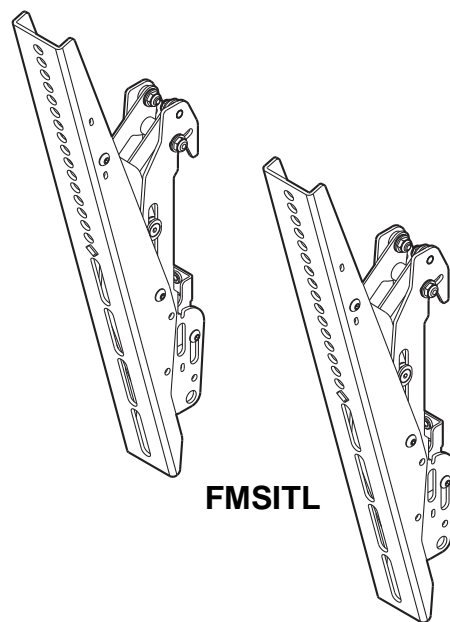
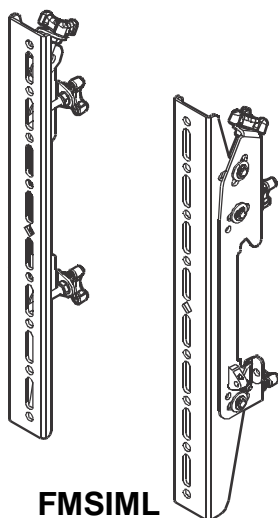
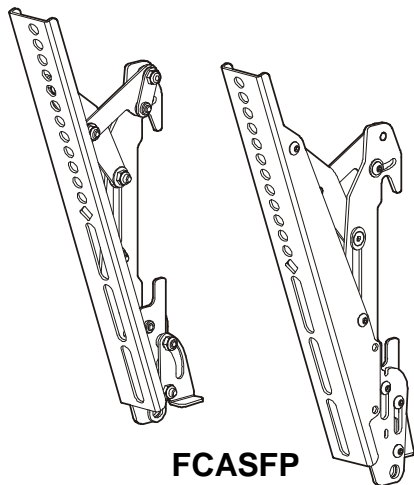

---

## Menu Board Interface Kits

---

**DISCLAIMER**

Milestone AV Technologies and its affiliated corporations and subsidiaries (collectively “Milestone”), intend to make this manual accurate and complete. However, Milestone makes no claim that the information contained herein covers all details, conditions or variations, nor does it provide for every possible contingency in connection with the installation or use of this product. The information contained in this document is subject to change without notice or obligation of any kind. Milestone makes no representation of warranty, expressed or implied, regarding the information contained herein. Milestone assumes no responsibility for accuracy, completeness or sufficiency of the information contained in this document.

Chief® is a registered trademark of Milestone AV Technologies. All rights reserved.

**DEFINITIONS**

**MOUNTING SYSTEM:** A MOUNTING SYSTEM is the primary Chief product to which an accessory and/or component is attached.

**ACCESSORY:** AN ACCESSORY is the secondary Chief product which is attached to a primary Chief product, and may have a component attached or setting on it.

**COMPONENT:** A COMPONENT is an audiovisual item designed to be attached or resting on an accessory or mounting system such as a video camera, CPU, screen, display, projector, etc.

 **WARNING:** A WARNING alerts you to the possibility of serious injury or death if you do not follow the instructions.

 **CAUTION:** A CAUTION alerts you to the possibility of damage or destruction of equipment if you do not follow the corresponding instructions.

 **IMPORTANT SAFETY INSTRUCTIONS**

 **WARNING:** Failure to read, thoroughly understand, and follow all instructions can result in serious personal injury, damage to equipment, or voiding of factory warranty! It is the installer’s responsibility to make sure all parts are properly assembled and installed using the instructions provided.

 **WARNING:** Failure to provide adequate structural strength for this accessory can result in serious personal injury or damage to equipment! It is the installer’s responsibility to make sure the structure to which the mounting system is attached can support five times the combined weight of all equipment.

 **WARNING:** Exceeding the weight capacity can result in serious personal injury or damage to equipment! It is the installer’s responsibility to make sure the combined weight of all components located on the accessory does not exceed the weight capacity listed in Table 1.

**Table 1: Weight Capacity**

Maximum Weight Allowed	
<b>FCASFP</b>	75 lbs (34.0 kg)
<b>FMSIML</b>	125 lbs (56.7 kg)
<b>FMSITL</b>	125 lbs (56.7 kg)

 **WARNING:** Use this accessory only for its intended use as described in these instructions. Do not use attachments not recommended by the manufacturer.

 **WARNING:** Never operate this accessory if it is damaged. Return the accessory to a service center for examination and repair.

 **WARNING:** Do not use this product outdoors.

**--SAVE THESE INSTRUCTIONS--**

TABLE OF CONTENTS	
<b>FCASFP.....</b>	<b>3</b>
<b>FMSIML.....</b>	<b>7</b>
<b>FMSITL.....</b>	<b>11</b>

**DIMENSIONS**

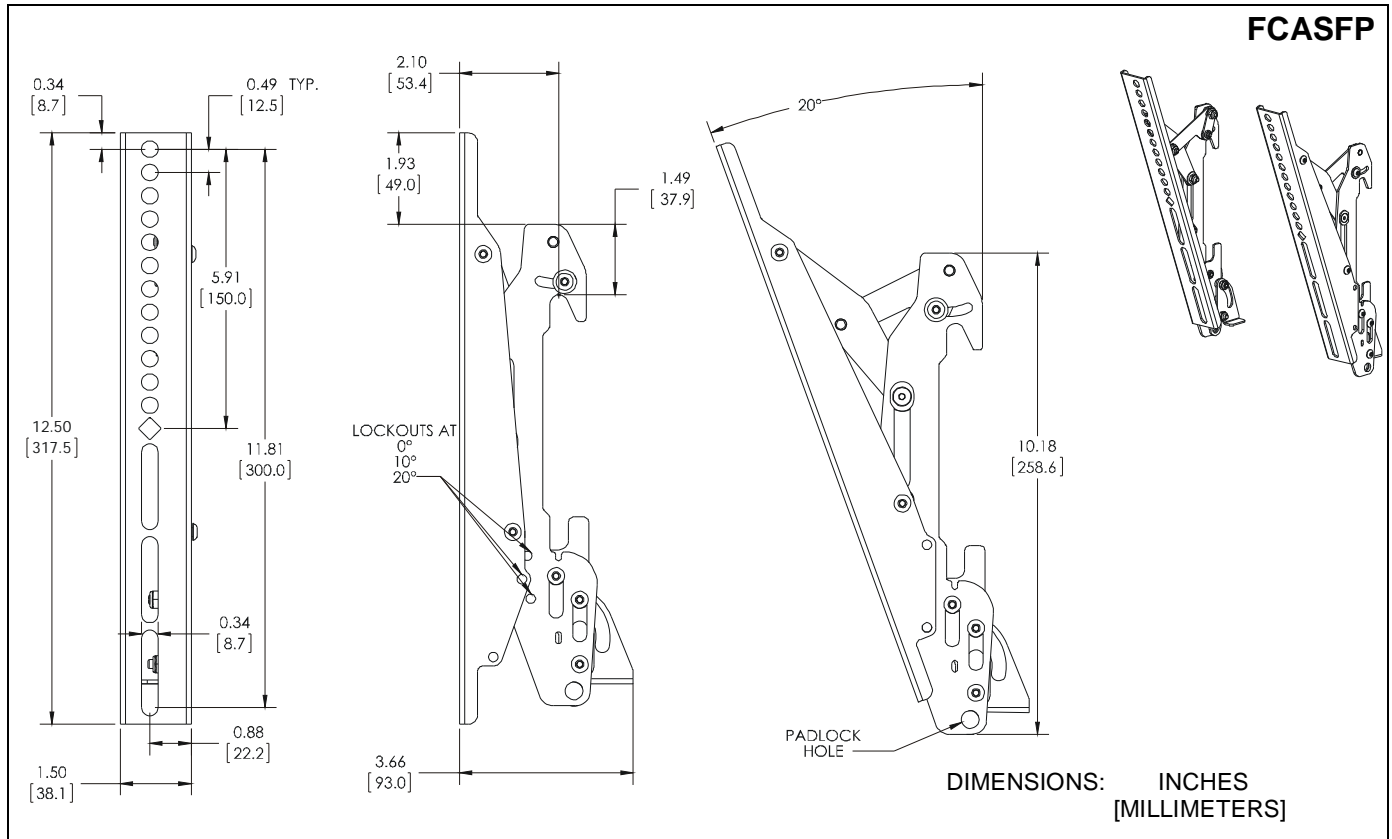

**FCASFP**

**LEGEND**





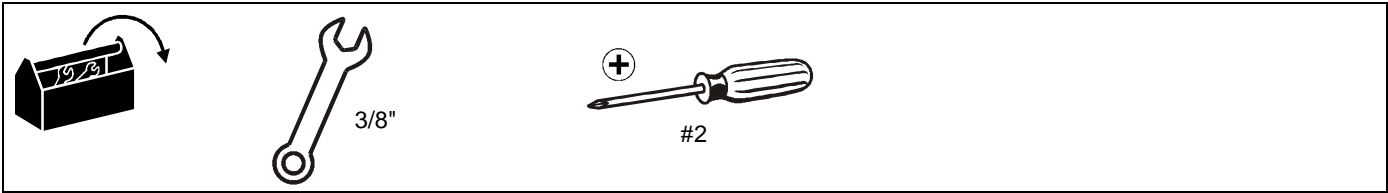









	<b>Tighten Fastener</b>		<b>Phillips Screwdriver</b>
	Apretar elemento de fijación		Destornillador Phillips
	Befestigungsteil festziehen		Kreuzschlitzschraubendreher
	Apertar fixador		Chave de fendas Phillips
	Serrare il fissaggio		Cacciavite a stella
Bevestiging vastdraaien	Kruiskopschroevendraaier		Tournevis à pointe cruciforme
Serrez les fixations			
	<b>Loosen Fastener</b>		<b>Open-Ended Wrench</b>
	Aflojar elemento de fijación		Llave de boca
	Befestigungsteil lösen		Gabelschlüssel
	Desapertar fixador	Chave de bocas	
	Allentare il fissaggio	Chiave a punte aperte	
Bevestiging losdraaien	Steeksleutel		
Desserrez les fixations	Clé à fourche		

**TOOLS REQUIRED FOR INSTALLATION - FCASFP**

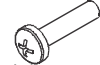



**PARTS - FCASFP**

**DISPLAY ATTACH HARDWARE BAG**  
(Letters correspond to letters on bag)

 A (4) M4x12mm	 B (4) M4x20mm	 C (4) M4x25mm
 D (4) M5x12mm	 E (4) M5x20mm	 F (4) M5x25mm
 G (4) M6x12mm	 H (4) M6x20mm	 I (4) M6x25mm
 J (4) M8x12mm	 K (4) M8x20mm	 L (4) M8x30mm
 MA (4) .750 x .323 x .250	 MB (4) .750 x .344 x .500	 N (4) [Universal washer]

**Locking Hardware Kit**

 P (2) 10-24 x 5/8"	 Q (2) 10-24
--	---

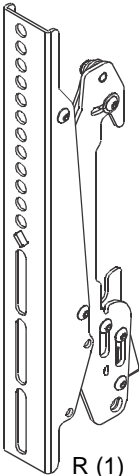
  
R (1)  
[Left interface bracket]

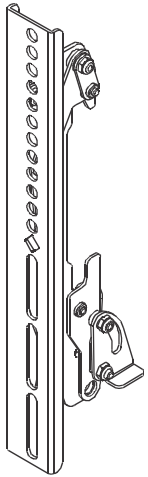
  
S (1)  
[Right interface bracket]

## INSTALL INTERFACE BRACKETS TO DISPLAYS

1. Raise the latch mechanism on both interface brackets (R and S) to the **OPEN** position. (See Figure 1)

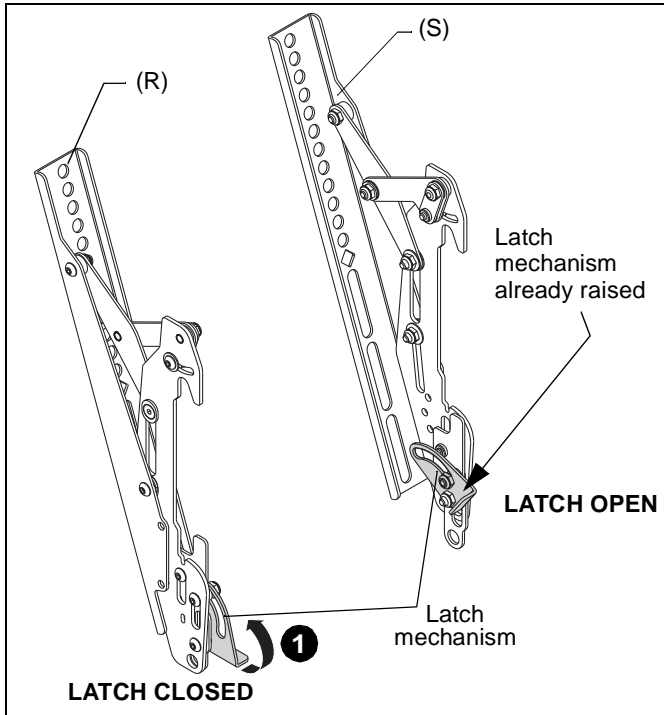

Figure 1

2. Place displays face down on a soft, non-abrasive surface.



**WARNING:** IMPROPER INSTALLATION CAN LEAD TO DISPLAY FALLING CAUSING SERIOUS PERSONAL INJURY OR DAMAGE TO EQUIPMENT! Using screws of improper size may damage your display. Properly sized screws will easily and completely thread into display mounting holes. If spacers are required, be sure to use longer screws of the same diameter.

3. Select screw *diameter* by examining hardware (A-L) and comparing with mounting holes on display. (See Figure 2)
4. Select spacers:
  - Spacers are **NOT** required if mounting holes are not recessed and interface brackets (R and S) can lay flat against display.
  - Spacers (MA or MB) **ARE** required if mounting holes are recessed, or if protrusions prevent interface brackets (R and S) from laying flat.
5. Select screw *length*: (See Figure 2)
  - By hand, insert **SHORTEST** length screw of selected diameter (A, D, G or J) through universal washer (N - if required), bracket (R or S), selected spacer (MA or MB-if required), into display mounting hole. Do **NOT** thread screw into hole at this time.

**IMPORTANT ! :** The M8 screws do **NOT** require a washer. Use the universal washer (N) **ONLY** with M4, M5 and M6 screws.

- Proper screw length requires base of screw head to protrude above flat washer a *distance equal to or greater than the screw diameter*. If screw length is inadequate, select longer screw. Select *shortest* screw which will protrude the required distance.

6. Align the center of the interface brackets (R and S) with center of screen. (See Figure 2)

**NOTE:** The diamond-shape hole in the bracket corresponds to the center of the mount.

7. Use selected screws (A-L), universal washers (N-if required) and spacers (MA or MB-if required), to connect interface brackets (R and S) to back of display. (See Figure 2)

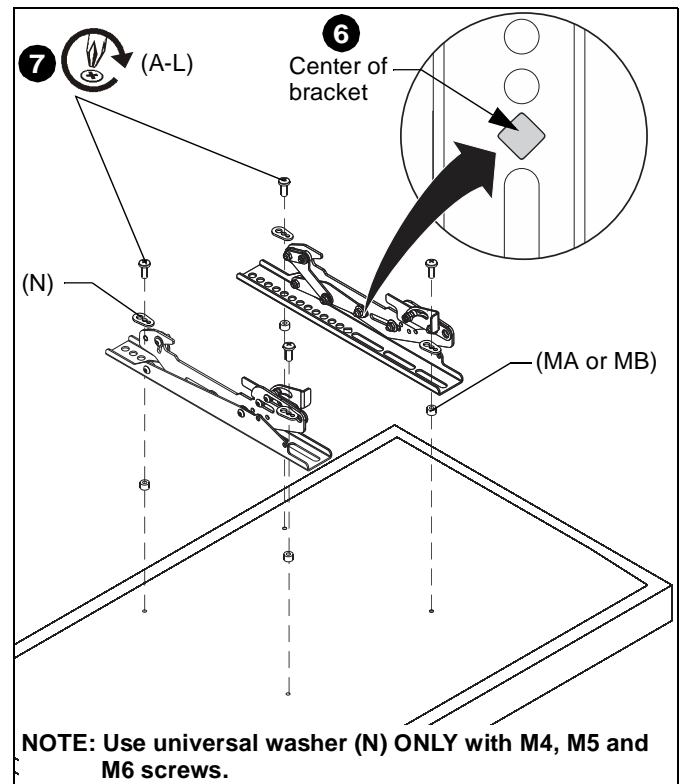

Figure 2

## ATTACH DISPLAYS TO MOUNTING RAIL

**WARNING:** IMPROPER INSTALLATION CAN LEAD TO DISPLAY FALLING CAUSING SERIOUS PERSONAL INJURY OR DAMAGE TO EQUIPMENT! The displays must be located approximately evenly across the length of the rail.

1. Ensure that the latch mechanisms on interface brackets (R and S) are already raised to the OPEN position. (See Figure 1)

**CAUTION:** BEFORE adding displays to the mounting rails, ensure end caps (FMSECAP) are in place at BOTH ends of mounting rail following instructions included with the FMSECAP.

2. While supporting both sides of display, lower display onto mounting rail, hooking top of interface brackets onto top of mounting rail. (See Figure 3)
3. Lower the latch mechanism on both interface brackets to lock bracket in place. (See Figure 3)

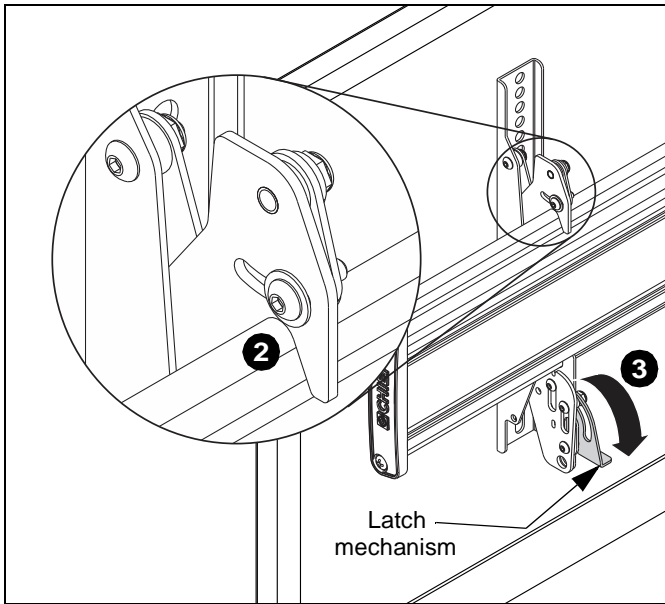

Figure 3

4. Repeat for remaining interface bracket.

### Interface Bracket Adjustment

**CAUTION:** ALWAYS keep a small distance between screens when making adjustments! Damage to screens possible if placed too close together.

#### Tilt

The interface brackets allow 0° to 20° tilt, and can be locked at 0°, 10° and 20° tilt.

5. If necessary, loosen button head tilt friction bolt (located on side of interface bracket). (See Figure 4)

6. Adjust tilt as required. (See Figure 4)
7. The tilt may be locked at 0°, 10° and 20° using one 10-24 x 5/8" Phillips head screw (P) and one 10-24 lock nut (Q) per interface bracket. (See Figure 4)
8. Tighten tilt friction bolt as necessary.

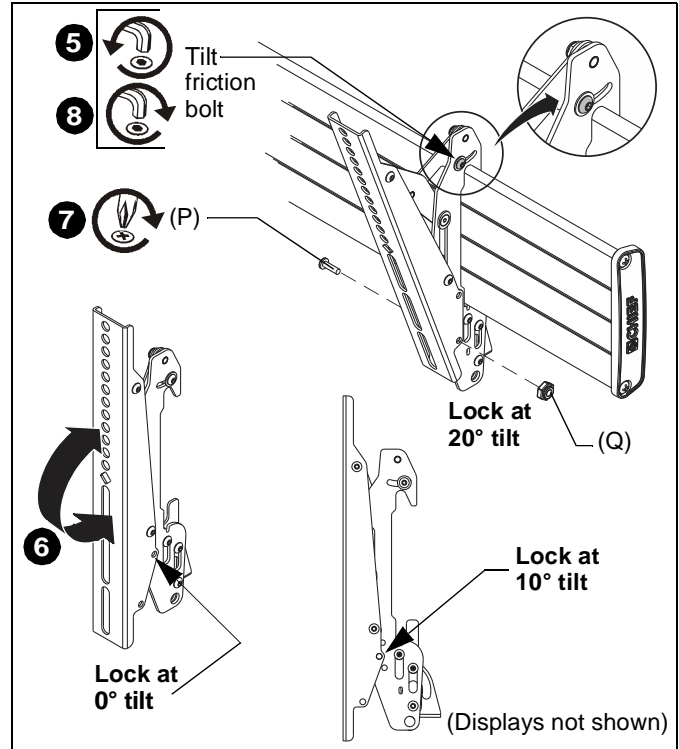

Figure 4

### OPTIONAL: Security

1. **OPTIONAL:** Add padlock (not included) to each interface bracket to lock display to mounting rail. (See Figure 5)

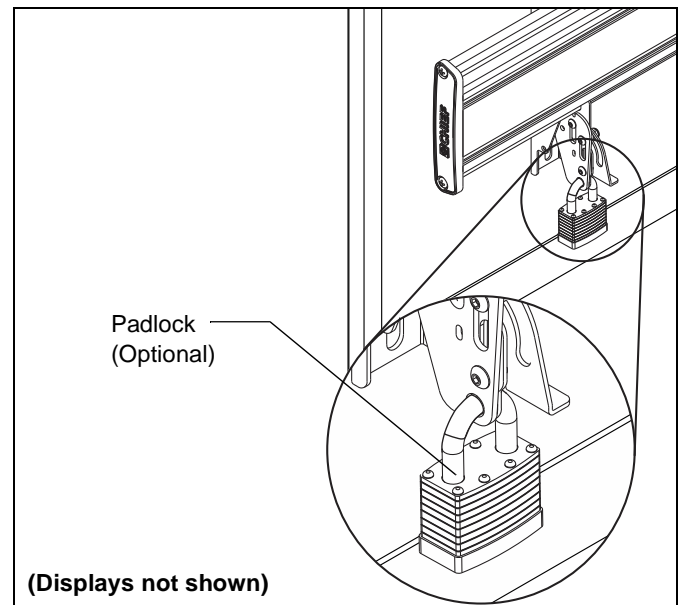
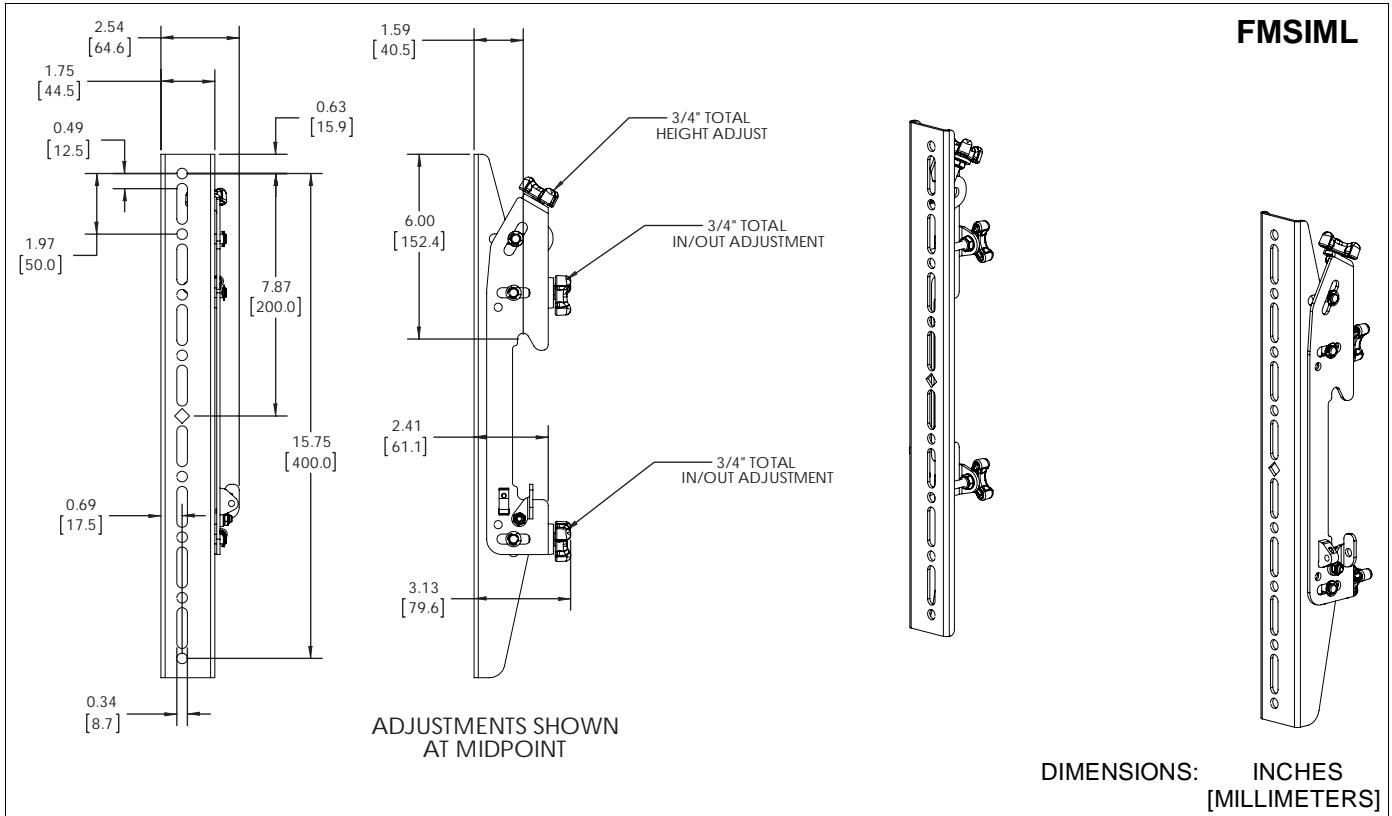

Figure 5

**DIMENSIONS**



**LEGEND**

	<b>Tighten Fastener</b>		<b>Phillips Screwdriver</b>
	Apretar elemento de fijación		Destornillador Phillips
	Befestigungsteil festziehen		Kreuzschlitzschraubendreher
	Apertar fixador		Chave de fendas Phillips
	Serrare il fissaggio		Cacciavite a stella
	Bevestiging vastdraaien		Kruiskopschroevendraaier
Serrez les fixations	Tournevis à pointe cruciforme		
	<b>Loosen Fastener</b>		<b>Open-Ended Wrench</b>
	Aflojar elemento de fijación		Llave de boca
	Befestigungsteil lösen		Gabelschlüssel
	Desapertar fixador		Chave de bocas
	Allentare il fissaggio		Chiave a punte aperte
	Bevestiging losdraaien		Steeksleutel
Desserrez les fixations	Clé à fourche		

**FMSIML**

**TOOLS REQUIRED FOR INSTALLATION - FMSIML**

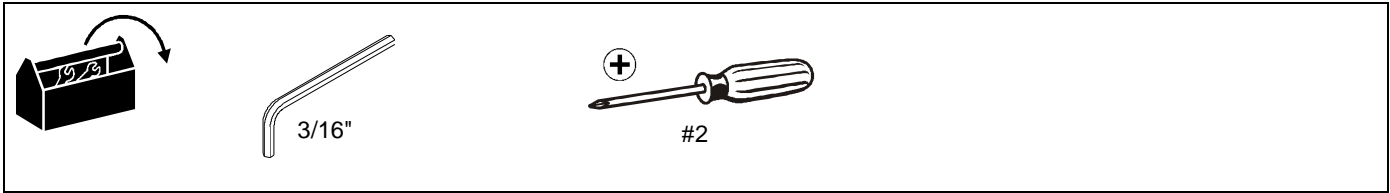

**PARTS - FMSIML**

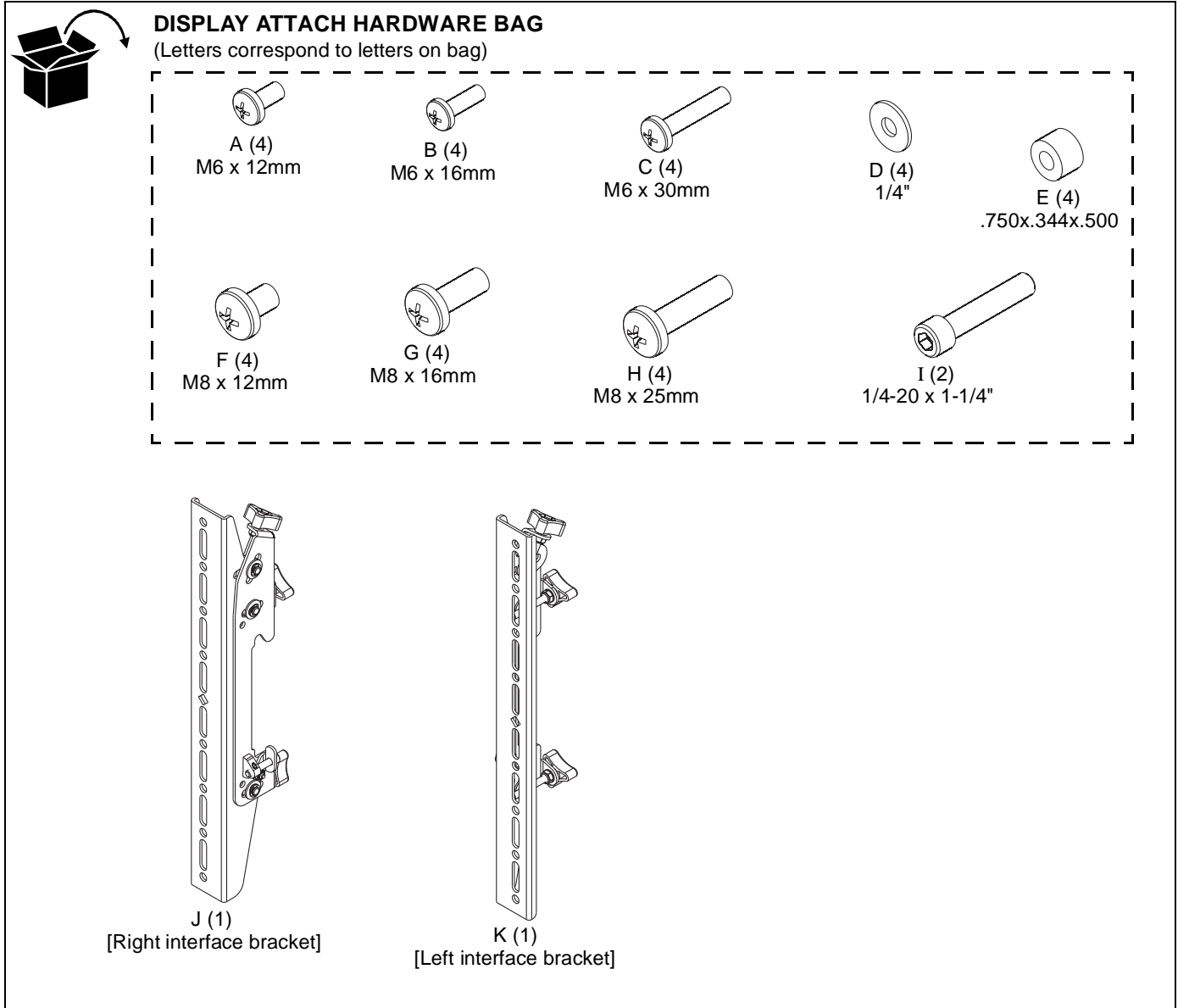



## INSTALL INTERFACE BRACKETS TO DISPLAYS

1. Place displays face down on a soft, non-abrasive surface.



**WARNING:** IMPROPER INSTALLATION CAN LEAD TO DISPLAY FALLING CAUSING SERIOUS PERSONAL INJURY OR DAMAGE TO EQUIPMENT! Using screws of improper size may damage your display. Properly sized screws will easily and completely thread into display mounting holes. If spacers are required, be sure to use longer screws of the same diameter.

2. Select screw *diameter* by examining hardware (A-C and F-H) and comparing with mounting holes on display. (See Figure 6)
3. Select spacers:
  - Spacers are **NOT** required if mounting holes are not recessed and interface brackets (J and K) can lay flat against display.
  - Spacers (E) **ARE** required if mounting holes are recessed, or if protrusions prevent interface brackets (J and K) from laying flat.

4. Select screw *length*: (See Figure 6)
  - By hand, insert **SHORTEST** length screw of selected diameter (A or F) through 1/4" washer (D), bracket (J or K), selected spacer (E, if required), into display mounting hole. Do **NOT** thread screw into hole at this time.
  - Proper screw length requires base of screw head to protrude above flat washer a *distance equal to or greater than the screw diameter*. If screw length is inadequate, select longer screw. Select *shortest* screw which will protrude the required distance.

5. Align the center of the interface brackets (J and K) with center of screen. (See Figure 6)

**NOTE:** The diamond-shape hole in the bracket corresponds to the center of the mount.

6. Use selected screws (A-C or F-H), washers (D) and spacers (E), if necessary, to connect interface brackets (J and K) to back of display. (See Figure 6)

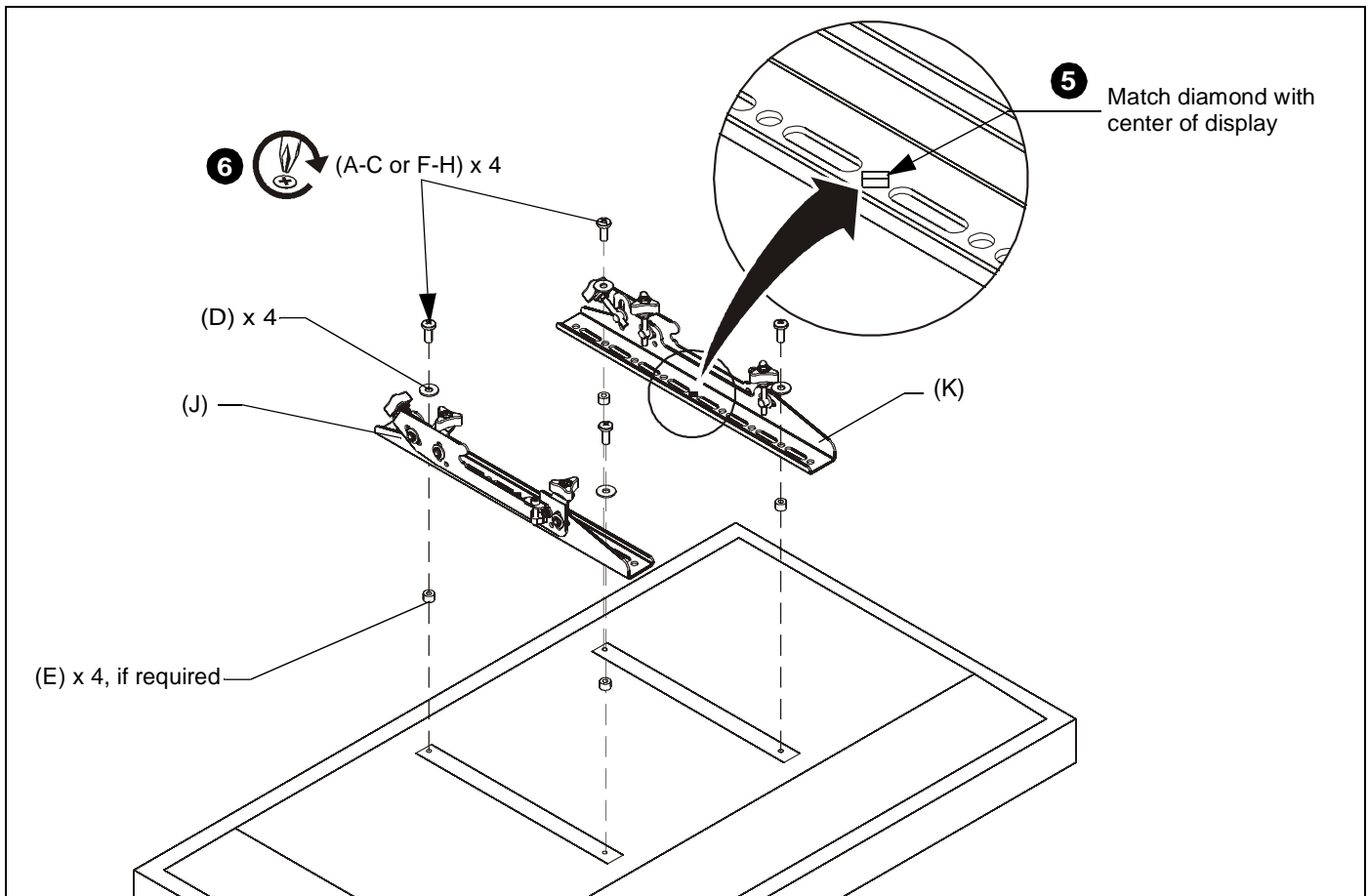

Figure 6

## ATTACH DISPLAYS TO MOUNTING RAIL

**⚠ WARNING:** IMPROPER INSTALLATION CAN LEAD TO DISPLAY FALLING CAUSING SERIOUS PERSONAL INJURY OR DAMAGE TO EQUIPMENT! The displays must be located approximately evenly across the length of the rail.

1. Ensure that the latch mechanisms on interface brackets (J and K) are already raised to the OPEN position. (See Figure 7)

**⚠ CAUTION:** BEFORE adding displays to the mounting rails, ensure end caps (FMSECAP) are in place at BOTH ends of mounting rail following instructions included with the FMSECAP.

2. While supporting both sides of display, lower display onto mounting rail, hooking top of interface brackets onto top of mounting rail. (See Figure 7)

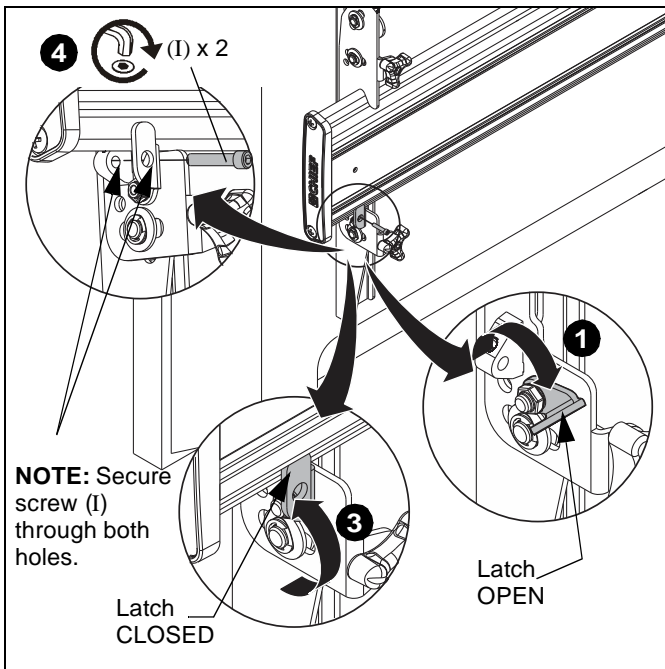

Figure 7

3. Raise latch on interface bracket and close into place against mounting rail. (See Figure 7)
4. Fasten latch into place using one 1/4-20 x 1-1/4" socket head screw (I). (See Figure 7)

**NOTE:** Socket head screws (I) must engage through both holes to be fully secured. (See Figure 7)

5. Repeat for each interface bracket on the mounting rail.

## Interface Bracket Adjustment

**⚠ CAUTION:** **ALWAYS** keep a small distance between screens when making adjustments! Damage to screens possible if placed too close together.

6. Move displays so that screens are nearly flush and level with each other.
7. Use upper knob on back of interface brackets (J and K) to adjust the height of each display. (See Figure 8)

**NOTE:** Adjust both brackets in order to maintain a level mount.

8. Use middle and lower knobs on back of interface brackets (J and K) to make plumb adjustments to each display. (See Figure 8)

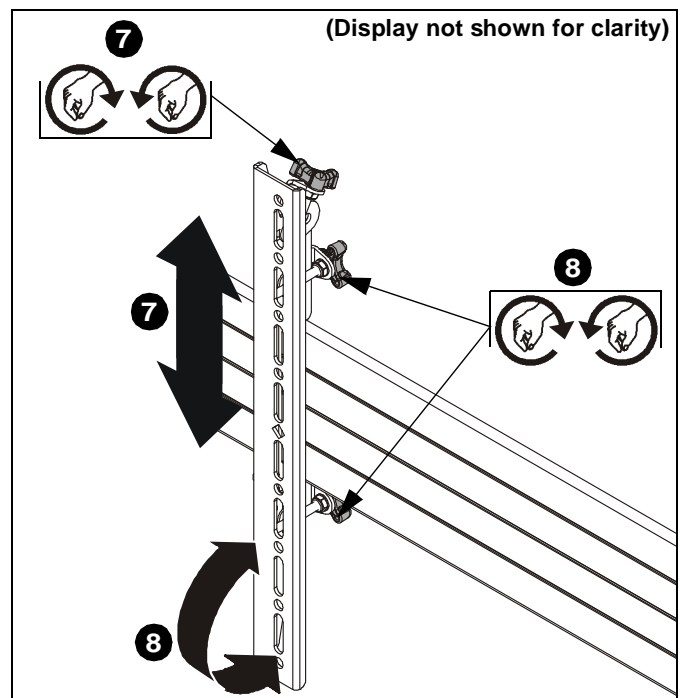
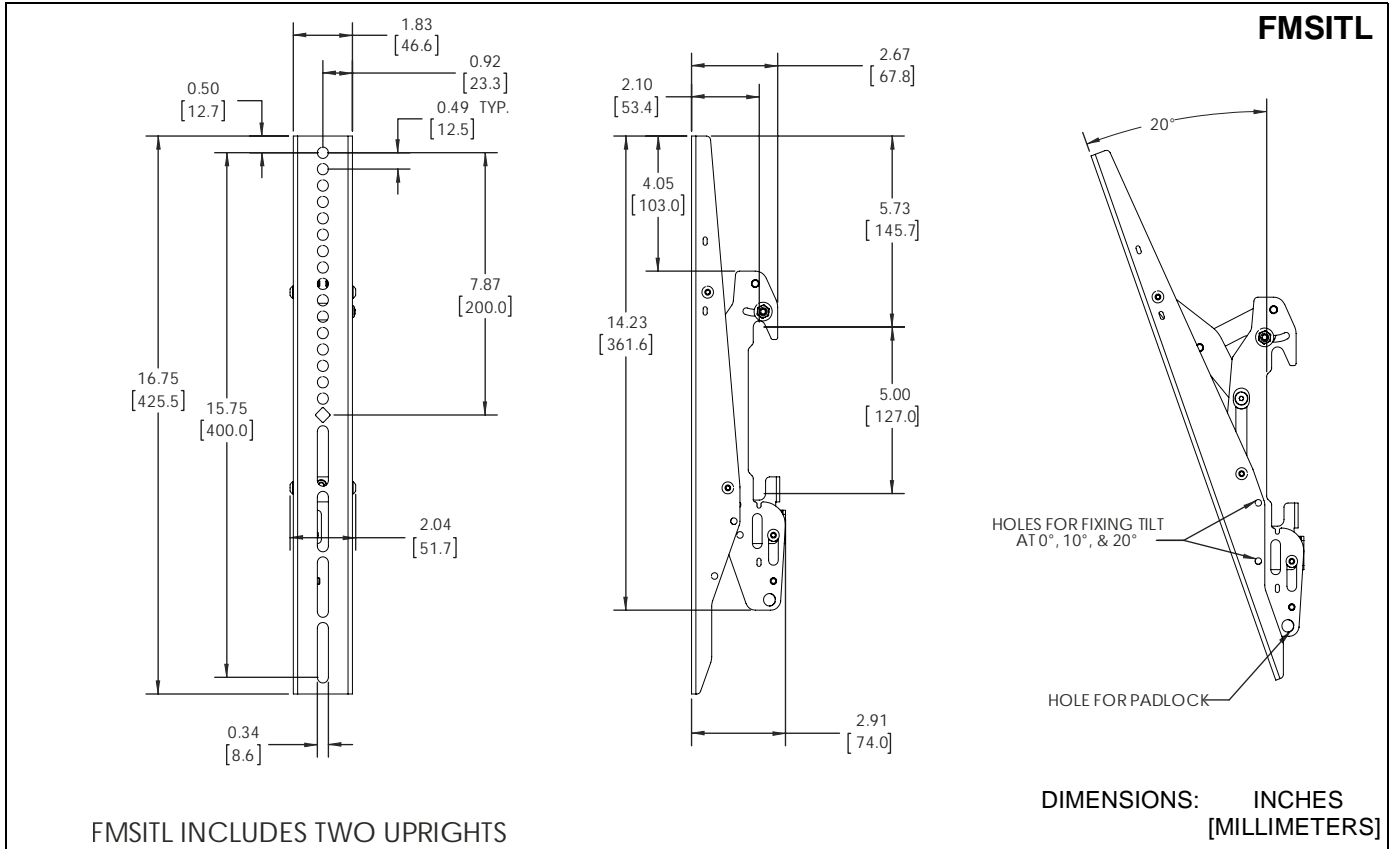

Figure 8

**DIMENSIONS**



**LEGEND**

	<b>Tighten Fastener</b>		<b>Phillips Screwdriver</b>
	Apretar elemento de fijación		Destornillador Phillips
	Befestigungsteil festziehen		Kreuzschlitzschraubendreher
	Apertar fixador		Chave de fendas Phillips
	Serrare il fissaggio		Cacciavite a stella
Bevestiging vastdraaien	Kruiskopschroevendraaier		<b>Open-Ended Wrench</b>
Serrez les fixations	Tournevis à pointe cruciforme		Llave de boca
	<b>Loosen Fastener</b>		Gabelschlüssel
	Aflojar elemento de fijación		Chave de bocas
	Befestigungsteil lösen		Chiave a punte aperte
	Desapertar fixador	Steeksleutel	
	Allentare il fissaggio	Clé à fourche	
Bevestiging losdraaien		<b>Hex-Head Wrench</b>	
Desserrez les fixations		Llave de cabeza hexagonal	
		Sechskantschlüssel	
		Chave de cabeça sextavada	
		Chiave esagonale	
	Zeskantsleutel		
	Clé à tête hexagonale		

**TOOLS REQUIRED FOR INSTALLATION - FMSITL**

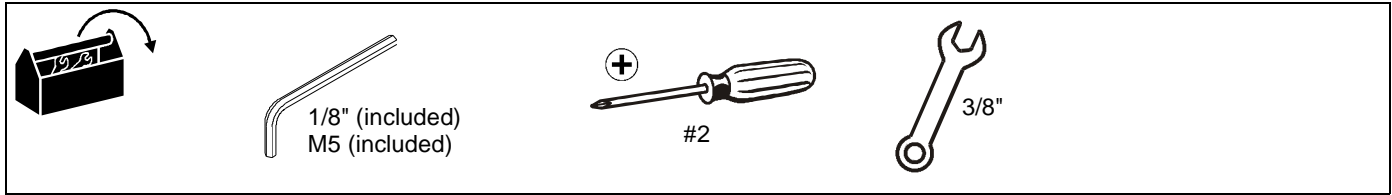

**PARTS - FMSITL**

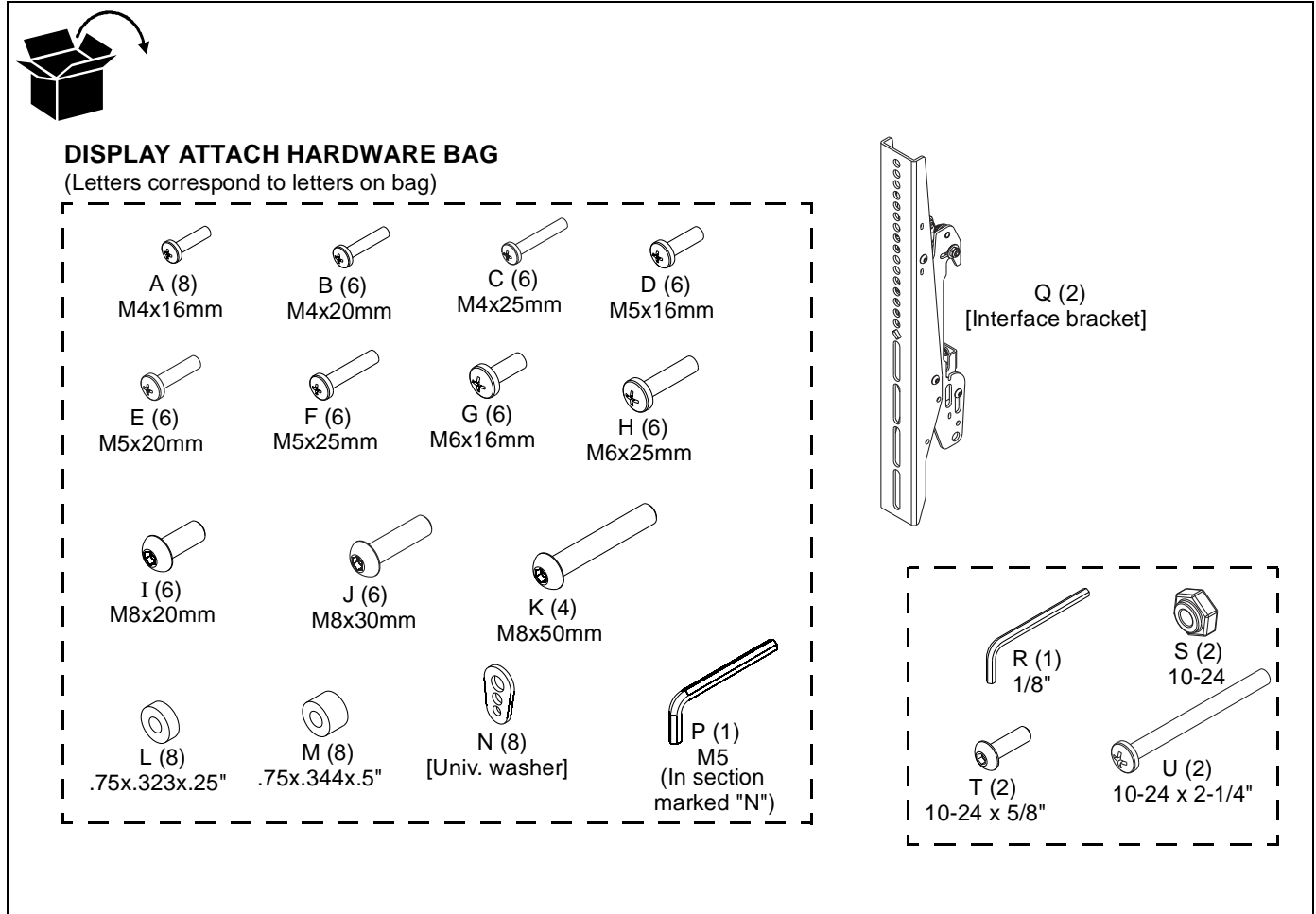

## INSTALL INTERFACE BRACKETS TO DISPLAYS

1. Lower the latch mechanism on each interface bracket (R). (See Figure 9)

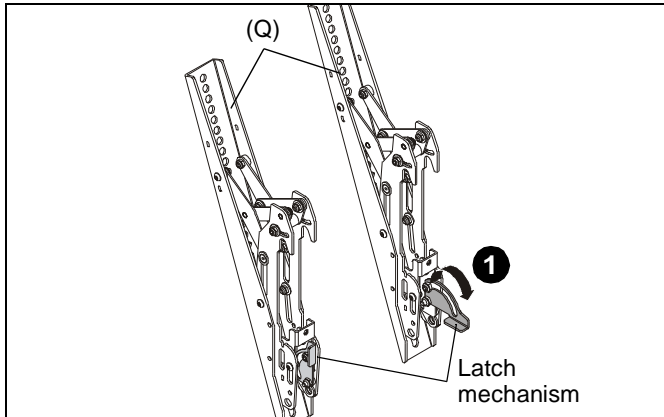

Figure 9

2. Place displays face down on a soft, non-abrasive surface.



**WARNING:** IMPROPER INSTALLATION CAN LEAD TO DISPLAY FALLING CAUSING SERIOUS PERSONAL INJURY OR DAMAGE TO EQUIPMENT! Using screws of improper size may damage your display. Properly sized screws will easily and completely thread into display mounting holes. If spacers are required, be sure to use longer screws of the same diameter.

3. Select screw *diameter* by examining hardware (A-K) and comparing with mounting holes on display. (See Figure 10)

4. Select spacers:

- Spacers are **NOT** required if mounting holes are not recessed and interface brackets (Q) can lay flat against display.
- Spacers (L or M) **ARE** required if mounting holes are recessed, or if protrusions prevent interface brackets (Q) from laying flat.

5. Select screw *length*: (See Figure 10)

- By hand, insert **SHORTEST** length screw of selected diameter (A, D, G or I) through universal washer (N - if required), bracket (Q), selected spacer (L or M-if required), into display mounting hole. Do **NOT** thread screw into hole at this time.

**IMPORTANT ! :** The M8 screws (I, J and K) do **NOT** require a washer. Use the universal washer (N) **ONLY** with M4 (A-C), M5 (D-F) and M6 (G and H) screws.

- Proper screw length requires base of screw head to protrude above flat washer a *distance equal to or greater than the screw diameter*. If screw length is inadequate, select longer screw. Select *shortest* screw which will protrude the required distance.

6. Align the center of the interface brackets (Q) with center of screen. (See Figure 10)

**NOTE:** The diamond-shape hole in the bracket corresponds to the vertical center of the mount.

7. Use selected screws (A-K), universal washers (N-if required) and spacers (L or M-if required), to connect interface brackets (Q) to back of display. (See Figure 10)

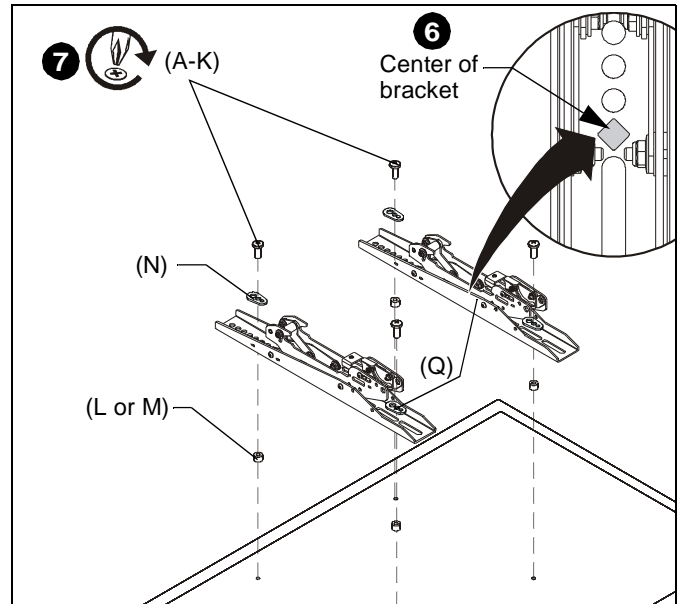

Figure 10

## ATTACH DISPLAYS TO MOUNTING RAIL



**WARNING:** IMPROPER INSTALLATION CAN LEAD TO DISPLAY FALLING CAUSING SERIOUS PERSONAL INJURY OR DAMAGE TO EQUIPMENT! The displays must be located approximately evenly across the length of the rail.

1. Ensure that the latch mechanisms on interface brackets (Q) are already lowered to OPEN position. (See Figure 11)



**CAUTION:** BEFORE adding displays to the mounting rails, ensure end caps (FMSECAP) are in place at BOTH ends of mounting rail following instructions included with the FMSECAP.

2. While supporting both sides of display, lower display onto one side of mounting rail, hooking top of interface brackets onto front of mounting rail. (See Figure 11)
3. Raise the latch mechanism on both interface brackets to lock bracket in place. (See Figure 11)

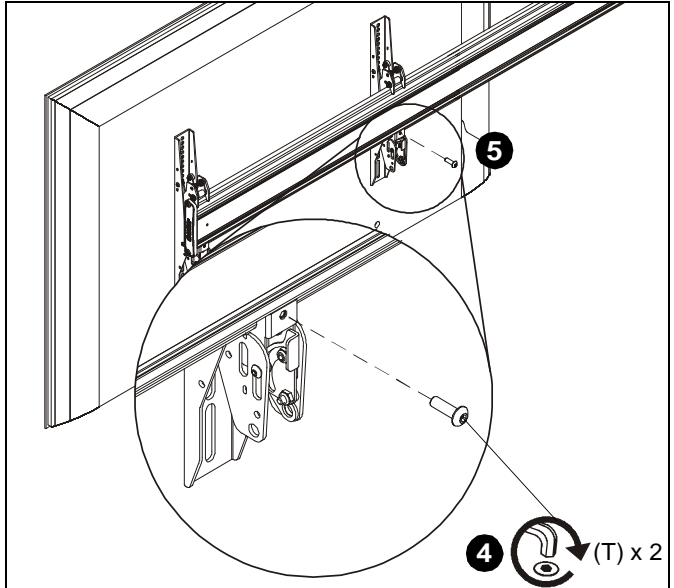

Figure 12

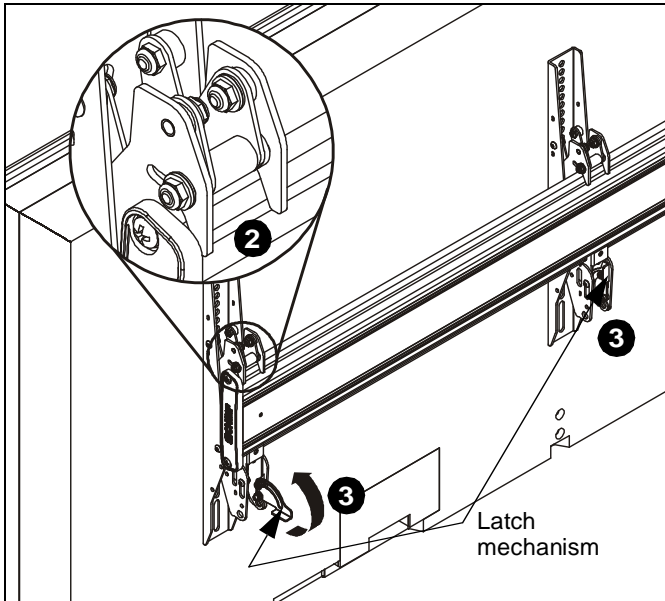

Figure 11

4. Fasten bracket against mounting rail using one 10-24 x 5/8" button head cap screw (T). (See Figure 12)
5. Repeat for other interface bracket.

### Interface Bracket Adjustment



**CAUTION:** **ALWAYS** keep a small distance between screens when making adjustments! Damage to screens possible if placed too close together.

#### Tilt

The interface brackets allow 0° to 20° tilt, and can be locked at 0°, 10° and 20° tilt.

1. If necessary, loosen button head tilt friction bolt (located on side of interface bracket). (See Figure )
2. Adjust tilt as required. (See Figure )
3. The tilt may be locked at 0°, 10° and 20° using one 10-24 x 2-1/4" Phillips head screw (U) and one 10-24 lock nut (S) per interface bracket. (See Figure )
4. Tighten tilt friction bolt as necessary.

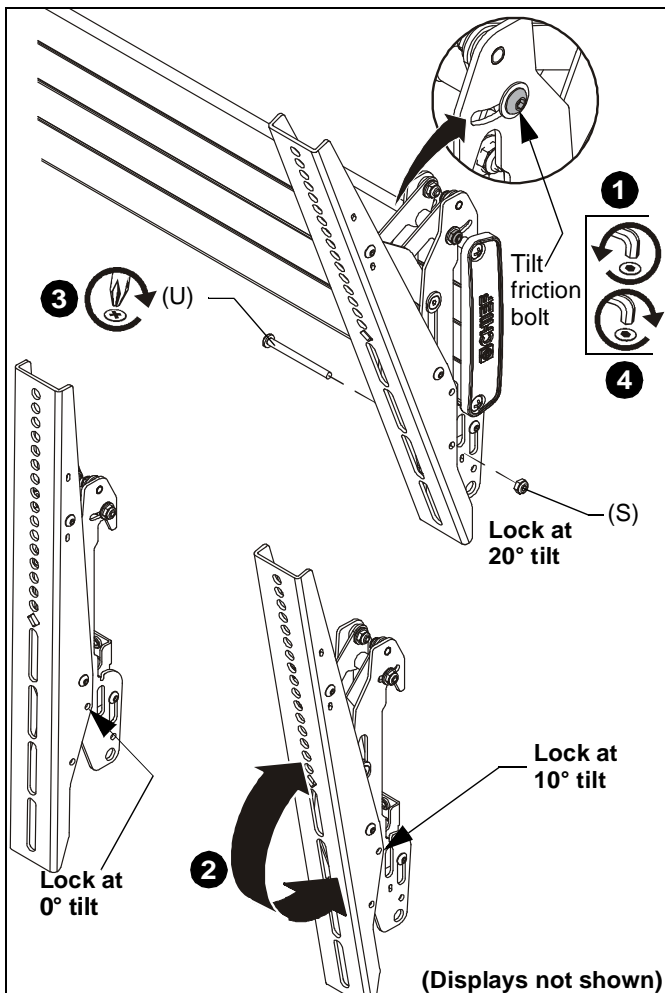

Figure 13

### OPTIONAL: Security

1. **OPTIONAL:** Add padlock (not included) to each interface bracket to lock display to menu board. (See Figure 14)

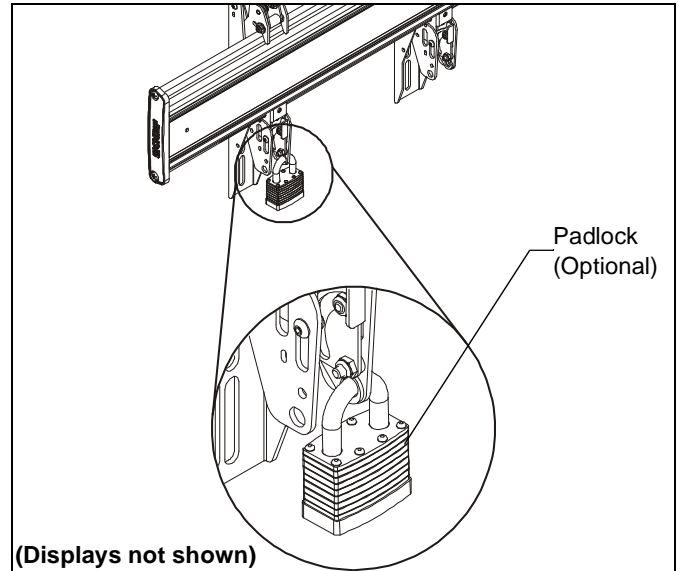

Figure 14



Our Mounts. **Your Vision.**

Chief, a products division of  
Milestone AV Technologies

8800-003032 Rev00  
©2018 Milestone AV Technologies  
[www.milestone.com](http://www.milestone.com)  
02/18

<b>USA/International</b>	<b>A</b> 6436 City West Parkway, Eden Prairie, MN 55344
	<b>P</b> 800.582.6480 / 952.225.6000
	<b>F</b> 877.894.6918 / 952.894.6918
<b>Europe</b>	<b>A</b> Franklinstraat 14, 6003 DK Weert, Netherlands
	<b>P</b> +31 (0) 495 580 852
	<b>F</b> +31 (0) 495 580 845
<b>Asia Pacific</b>	<b>A</b> Office No. 918 on 9/F, Shatin Galleria 18-24 Shan Mei Street Fotan, Shatin, Hong Kong
	<b>P</b> 852 2145 4099
	<b>F</b> 852 2145 4477

