

**Saitek®**



**X-56 RHINO H.O.T.A.S. SYSTEM™**  
**HANDS ON THROTTLE AND STICK**

**USER MANUAL**

## Welcome Message from the Developers

The Saitek Pro Flight team thanks you for purchasing this groundbreaking piece of Pro Flight hardware. Rest assured that, as with all the products we've developed over the years, a wealth of knowledge, skill, and endeavor went into the development phase. Thanks to our dedicated pool of beta testers – comprised of actual pilots and sim pilots – we created a piece of hardware to satisfy your needs for years to come. Combine this product with others in the range, like the Combat Rudder Pedals and Pro Flight Instrument Panels, and Saitek Pro Flight becomes a one-stop-shop for all your combat flying equipment.

TheSaitekProFlightTeam



## STICK OVERVIEW

- A. POV
- B. Thumb Pickle Button
- C. Thumb HATs, Witches and Castle
- D. Stick Buttons with Trigger and 2 x Head Buttons
- E. X, Y, and Rz Axes, Elevator, Aileron and Rudder Axes
- F. Pinkie and Flying Pinkie
- G. F.E.E.L. Spring System



## THROTTLE OVERVIEW

- A. Throttle Rotaries with inset buttons
- B. 2-position Slider
- C. Thumb Controls with 2 HATs, Thumb Button, Mini AnalogStick
- D. Twin Throttles with Throttle Lock
- E. Throttle Tension Adjuster
- F. 3-position Mode Switch
- G. Base Controls with 7 Toggles and 2 Rotaries

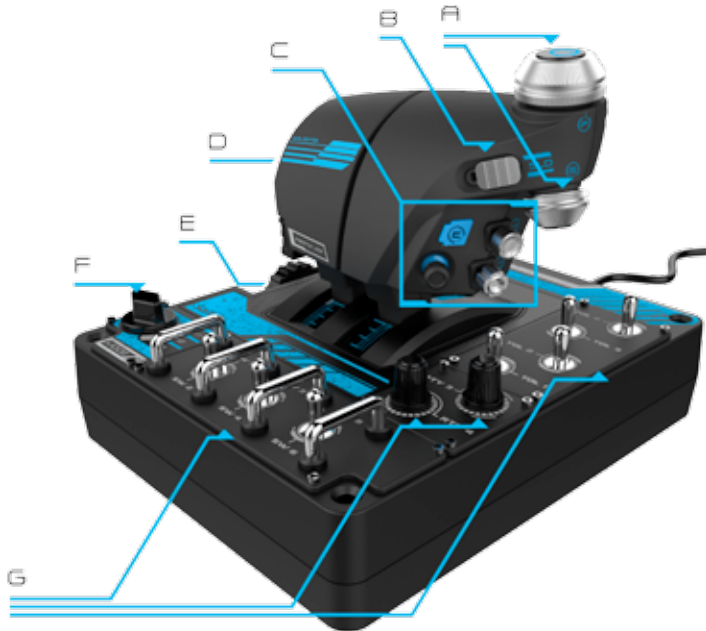

## GETTING STARTED

### Drivers and Software Installation

#### Windows® 8/10 (32- and 64-bit)

##### ***A) Drivers Only***

1. Download and install the X-56 Rhino Software from [www.saitek.com](http://www.saitek.com)
2. After reading the Disclaimer, select the **'I accept the terms of the Disclaimer'** option and click **'Next'** to continue
3. At the **Plug In** screen, plug the Stick and Throttle units into the PC. Click **'Next'** when it becomes highlighted
4. The **Windows Security** popup will ask **'would you like to install this device software?'** Before clicking install, check the box that says **'always trust software from Mad Catz Ltd.'** Now click **'Install'**
5. At the next screen, click **'Next'** to go to the **Controller Test page**
6. Use the **Controller Test** page to test all the X-56's axes, buttons and functions. Once you have tested all the functions, click **'OK'** to continue
7. From the end screen, click **'Finish.'** Your drivers are now installed

##### ***B) H.U.D. Software***

1. Download and install the X-56 Rhino Software from [www.saitek.com](http://www.saitek.com)
2. After clicking **'Run setup.exe,'** your Windows 8 system will drop out of the Metro/Start screen and ask via popup if **'you want to allow the following program to make changes to this computer.'** Click **'Yes'**
3. After reading the Disclaimer, select the **'I accept the terms of the Disclaimer'** option and click **'Next'** to continue. The H.U.D. Software will now install
4. On the finish screen, you can use the checkbox to run the H.U.D. Software when you click **'Finish,'** or remove the check mark from the checkbox to just finish the installation

##### ***C) .NET Framework***

1. If this is the first Mad Catz product that you have installed, you may be asked to install .NET Framework after the HUD Software installation finishes. **This is strongly recommended; this Microsoft Feature Update is required by the HUD Software**
2. Click **'Download and install this file.'** The PC will now find the correct files from the Internet and download them
3. When the installation finishes, click **'Close'**

## Windows® 7 (32- and 64-bit)

---

### A) Drivers Only

1. Download and install the X-56 Rhino Drivers from [www.saitek.com](http://www.saitek.com)
2. After reading the Disclaimer, select the '**I accept the terms of the Disclaimer**' option and click '**Next**' to continue
3. At the **Plug In** screen, plug the Stick and Throttle units into the PC. Click '**Next**' when it becomes highlighted
4. The **Windows Security** popup will ask '**would you like to install this device software?**' Before clicking install, check the box that says '**always trust software from Mad Catz Ltd.**' Now click '**Install**'
5. At the next screen, click '**Next**' to go to the Controller Test page
6. Use the **Controller Test** page to test the X-56's axes, buttons, and functions. After testing, click '**OK**' to continue.
7. From the end screen, click '**Finish.**' Your drivers are now installed

### B) H.U.D. Software

1. Download and install the X-56 Rhino Software from [www.saitek.com](http://www.saitek.com)
2. After reading the Disclaimer, select the '**I accept the terms of the Disclaimer**' option and click '**Next**' to continue. The HUD Software will now install
3. On the finish screen, you can use the checkbox to run the HUD Software when you click '**Finish,**' or remove the check mark from the checkbox to just finish the installation

### C) .NET Framework

1. If this is the first Mad Catz product that you have installed, you may be asked to install .NET Framework after the HUD Software installation finishes. **This is strongly recommended; this Microsoft Feature Update is required by the HUD Software**
2. Click '**Download and install this file.**' The PC will now find the correct files from the Internet and download them
3. When the installation finishes, click '**Close**'

## CONTROLLER SETTINGS

If at any time you wish to check that the X-56 is working correctly, open the **Game Controllers** page and click on the controller's **Properties** tab.

Here are the various ways to do this from each operating system:

### Windows® 8/10 (all 32- and 64-bit versions)

1. From the **Metro/Start** screen, click the **'Control Panel'** icon. **NOTE:** If you have no Control Panel icon on your Metro/Start screen, type **'control panel'** and the icon for the **Control Panel** will appear
2. Once the **Control Panel** is open, double-click on the **'Devices and Printers'** icon. **NOTE:** If you cannot see this icon, make sure that you have large icons selected
3. With the **Devices and Printers** screen open, find the **X-56 Rhino** in the device list and right-click on this icon. From the dropdown menu, select **'Game Controller Settings'**
4. From the **Game Controllers** window, you should see the X-56 Rhino listed and selected. Click **'Properties'** and this should take you to the **Controller Test** screen

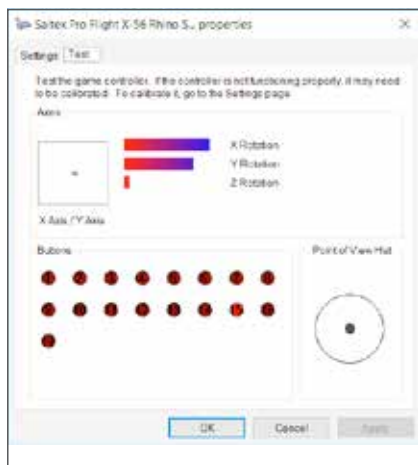

From the **Controller Test** screen you can test all the functions, axes, buttons, rotaries, etc. When you have completed your tests, click **'OK'** twice to get back to the main desktop

### Windows® 7 (all 32- and 64-bit versions)

1. Click on the **'Windows'** icon from the system tray. Hover over the **All Programs** menu. Click the **'Games'** folder and then the **'Games Explorer'** icon
2. Click the **'Tools'** option (with downward facing arrow) from the list across the top of the window. From the dropdown list, click **'Input Devices'**
3. From the **Game Controllers** window, you should see the X-56 Rhino listed and selected. Click **'Properties'** and this should take you to the **Controller Test** screen

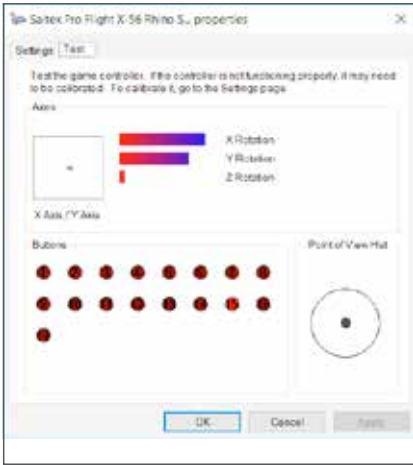

From the **Controller Test** screen you can test all the functions, axes, buttons, rotaries, etc. When you have completed your tests, click 'OK' twice to get back to the main desktop



## F.E.E.L. Spring Tension System

Each spring placed on the Rhino stick shaft will give a different feeling. You can also operate the stick without a spring, providing a total of five different forces.

Each spring has a unique feel and different identification. These identifiers are color swatches at the top of each spring – Red, Yellow, Blue, and Green. This table lists some of the calculations used for differentiation:



	RED	GREEN	YELLOW	BLUE	Notes
k = Rate	1	2	3	4	
<b>OD = Outside diameter</b>	<b>33</b>	<b>33</b>	<b>33</b>	<b>33</b>	
<b>d = Wire diameter</b>	<b>1.8</b>	<b>1.8</b>	<b>1.8</b>	<b>1.8</b>	
E = Youngs Modulus ( 210000 )	210000	210000	210000	210000	N/mm2
<b>FL = Free length</b>	<b>52</b>	<b>47</b>	<b>42</b>	<b>36</b>	Un-compressed
WL = Working length	30.8	30.8	30.8	30.8	Pre-compressed
P1L = Position 1 length	25.8	25.8	25.8	25.8	Full Working Compression
n = Total Number of coils	4.5	4.5	4.5	4.5	Active coils (6.5 coils in spring)
D = Mean Diameter	31.2	31.2	31.2	31.2	
Rate K= $Ed^4 / 8n D^3$	1.70	1.70	1.70	1.70	N/mm
<b>Load @ Breakout BL = FL-WL x k</b>	<b>36.12</b>	<b>27.60</b>	<b>19.08</b>	<b>8.86</b>	N
<b>Load @ P1L SoL = FL - SL x k</b>	<b>44.64</b>	<b>36.12</b>	<b>27.60</b>	<b>17.38</b>	N
Stress= $8 \times P \times D / 3.14 \times d^3$	608.50	492.38	376.25	236.90	N/mm2
<b>% UTS ( M4 Music Wire )</b>	<b>30.89</b>	<b>24.99</b>	<b>19.10</b>	<b>12.03</b>	%

## Changing or removing a spring

To insert, change, or remove a spring, follow these steps. Ensure the trigger is facing away from you and that the X-56 Rhino logo plate is facing you.

1. Turn the Locking Bezel (part B) counterclockwise until the Stick comes away from the base.
2. Remove the Seal Ring (part C) by placing the fingers from your left and right hand under the ring on either side, and then lift up. The Seal Ring is stiff by design.
3. Pry apart the Locking Clamps (part D). These pull apart from the stick, but are under load from the spring. Take one half off first, hold the spring, and then remove the other half.
4. Remove the Spring (part E), then either replace with a new Spring or leave the Spring off.

To reassemble, reverse the order of the above steps, making sure to securely seat the Seal Ring (Part C) and firmly tighten the Locking Bezel (part D) on the Stick base.



1. Turn Locking Bezel counterclockwise



2. Remove Stick



3. Remove Seal Ring



4. Pry apart Locking Clamps



5. Remove Spring

## H.U.D. Software Overview

H.U.D. Software allows you to program the X-56 Rhino with an array of keyboard commands, from basic single-key commands to very advanced, timed, and macro commands. It will also allow you to program any axis with keyboard commands, and program mouse commands.

In the H.U.D. Software you can also alter the response curves and deadbands of the main axis – we'll cover the explanation of these topics later in the manual.

### There are two ways to launch the H.U.D. Software:

1. From the desktop icon that looks like this
2. From the start menu bar...

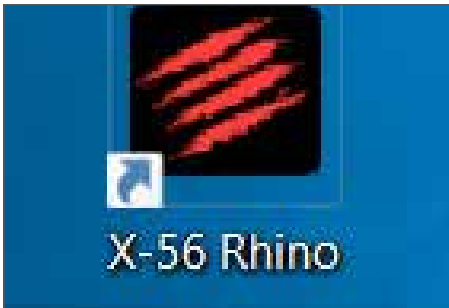

Once the H.U.D. Software launches, you will be presented with the Home Screen.

If it's the first time you've run the H.U.D. Software, you will be asked to choose your language. Once this is done the main Home Screen will appear. If you've made a mistake choosing your language or you wish to choose another language, the language menu can be accessed by clicking on the icon in the bottom-right corner of the Home Screen.

### There are four main Tabs within the H.U.D. Software:

1. HOME
2. PROGRAMMING
3. SETTINGS
4. SUPPORT

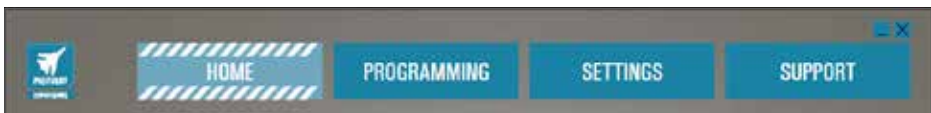

HOME TAB



On the Home screen you'll see:

- Close-up of the product
- Related products that we feel that you would be interested in
- Live Facebook feed from Saitek Pro Flight
- Social media and website short cuts, Saitek.com, Twitter, YouTube, Instagram, etc
- Language selection, use the flag icon in the bottom-right corner to access this

## PROGRAMMING TAB

After selecting the PROGRAMMING Tab you will see the X-56's programming environment.

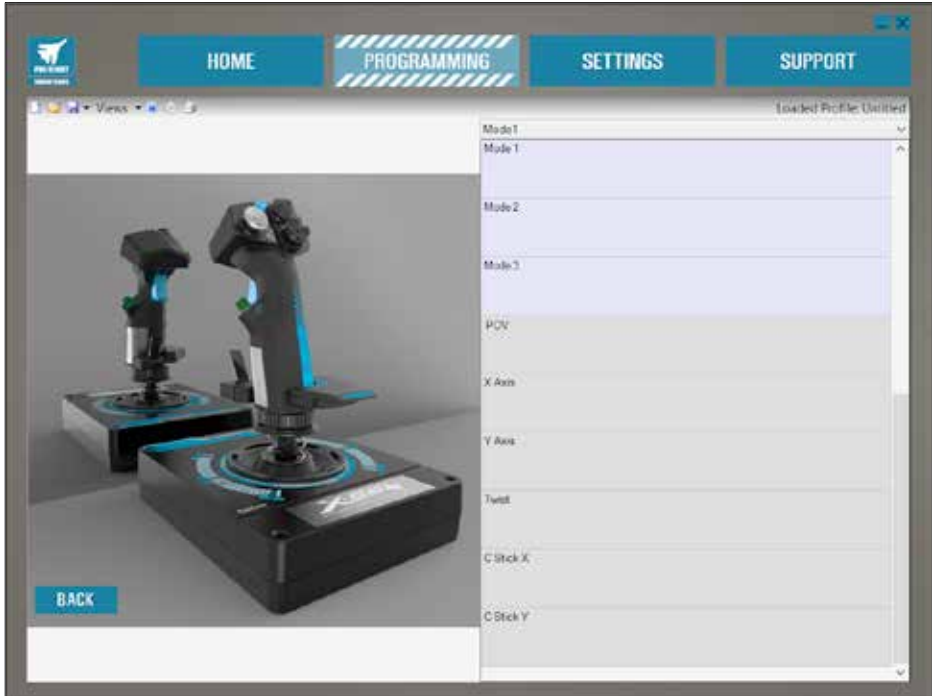

You will see a high-resolution image of the controller you are going to program on the left side of the screen. On the right side of the screen you will see a list of command boxes, called "Cells," going down the page.

At the top of the image panel you will see Stick and Throttle icons. Clicking on either of these will change the current unit you are programming. The unit you are programming is easily recognizable by the larger image that fills the window.

In the PROGRAMMING Tab you can mimic your controller to directly copy any of the keyboard commands used in your favorite games. The commands are then saved in what we call a Profile.

### What is a Profile?

A Profile is the name given to a file that has programmed controller commands saved into it. For example, you may have a Joystick with a number of buttons/hats. If you want one of these to do something in-game that you would normally have to use a keyboard shortcut for, you can "assign" that command to that button. If you want Button 'A' to activate the landing gear (which is the "G" key on a keyboard), you can use the H.U.D. Software to assign this function. You can also create more complicated assignments, like "shift+F2," or even timed commands and macros.

## Making your first Profile

1. Either hover the mouse pointer over the Cell, or press the button you want to create a Profile for on the controller. If you hover your mouse over the **Button 'A'** Cell, **Button 'A'** will light up on the 3D Joystick image. Or just click **Button 'A'** on the stick and the correct Cell will light up.

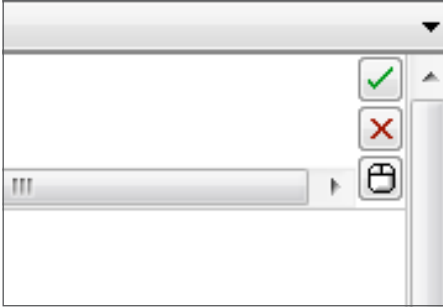

2. When the correct Cell is lit, left-click in it and a large flashing cursor will appear in the left side of the Cell. You will also see a green tick, a red cross, and a mouse icon on the right side of the Cell.

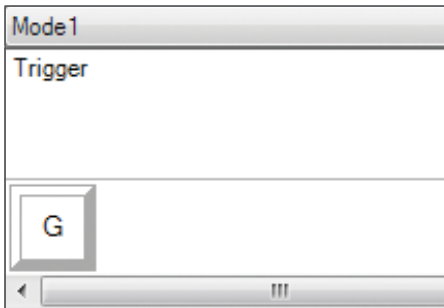

3. The Cell is now waiting for the keyboard command. Using your keyboard, press the button on the keyboard you would like **Button 'A'** on the stick to activate. For this example we will use the **'G'** key, which usually activates landing gear. When you press **'G'** on the keyboard, a large white tile with the letter **'G'** should appear in the Cell, as shown here.

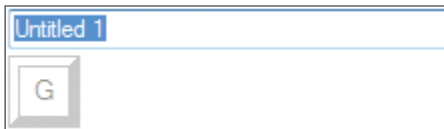

4. If this is the correct keyboard command, press the green tick icon on the right side. If not, press the red cross and redo the procedure to get the keyboard command into the Cell again. After pressing the green tick icon, the command name box will appear, labeled as "Untitled" (left image, below). Simply choose a name for the command and type the name into this box. For this example, we chose "Landing gear." Press the enter key to complete the Cell. **Button 'A'** = Landing gear, which is your keyboard's **'G'** key (right image, below).

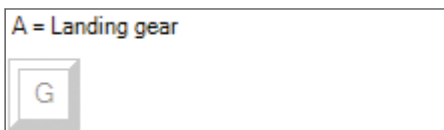



5. Test your Profile by opening the “Testing” window. Above the 3D image there are seven icons. The one that is second from the right, which looks like a silver cog, is labeled “Test Profile.”

Click on this icon and a new window will open. A cursor will already be flashing in the test area. Simply press **Button ‘A’** on the X-56. When this is pressed, letter ‘G’ will appear in the window, which proves your first programmed button is working.

Close this window by clicking on the “OK” icon in the bottom-right corner of the Testing window.

6. You can add other keyboard commands if you wish and then test them. Just remember to save your work before you shut down the H.U.D. Software.

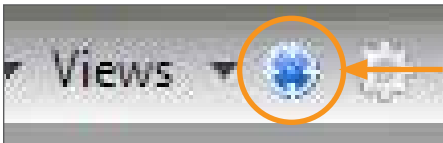

7. To make the programming you have just created work in your game, you must first save it as a Profile and then activate it. This can be done with one click. In the icon row just above the 3D image, you will see an icon that looks like a blue target. If you hover over this icon a tool tip labeled “Profile” will appear.

Click this icon and a standard Windows save box will appear. Give your Profile a name and save it. After saving, the Profile will become active and you can shut down the H.U.D. Software and play your game. The X-56 will now respond as you have programmed it.

8. The H.U.D. Software is capable of many other powerful programming features that we have not yet covered. For example, you can program axes, mouse movement and mouse buttons, hats, and special timed or complicated commands. For a full list of features and full manual please go to the **SUPPORT** Tab and click on “Read H.U.D. Programming Manual,” or watch the specially designed H.U.D. programming video.

## Icons in the Profile Editor



### 1. **New Profile**

Opens a blank Profile for you to edit/build.

### 2. **Open Profile**

Opens a previously created Profile for editing.

### 3. **Save Profile**

Clicking “Save” will save a new Profile or overwrite a current Profile.

Using the drop-down arrow next to “Save,” you can “Save as,” allowing you to save the current Profile to a different location or as a different name.

### 4. **Views**

You can change the view in the Profile Editor to be just programming Cells (i.e., no image). Clicking the “Views” button again will restore the default view and the image will reappear.

### 5. **Profile**

If you are working on a Profile to use immediately, so you can get flying straight away, click here.

### 6. **Test Profile**

Clicking this icon will bring up the test window. This is especially useful if you are attempting to program advanced timed or macro commands as it gives you a place to test your work before you fly.

### 7. **Print**

By pressing this icon, the Profile that you are currently building will be sent to the default printer on your system.



## Settings

The settings page will allow you to alter the deadzone and response curves of all axes on both the Stick and the Throttle.

### Response Curves

Depending on the type of aircraft that you fly, you may want your joystick to be more or less sensitive around the middle or end points of the axes. For example, if you're flying an F/18 on a refueling mission at 25,000 feet, you will be making very fine movements to get into the correct position. Having a shallower response curve around the center point of the joystick's X and Y axes will enable you to make very fine adjustment to your aircraft.

### Deadbands

A deadband, sometimes known as a deadzone or neutral zone, is a part of the range in which an axis moves, undetected by the drivers and without effect on in-game progress. It may be around the center point of the axis range, or at either end of the axis range.

### Axis Range Adjustment

The axis range adjustment, or axis saturation to assign its correct name, allows you to shrink the raw data range of an axis.

### Physical Axis Adjustment

The physical axis adjustment, or physical saturation, allows you to shrink the full axis data range into a small physical stick movement.

### S-Curves and J-Curves

There are two types of adjustable curves – S-Curves and J-Curves. J-Curves are linear axes, like throttles and rotaries. S-Curves are non-linear, like X and Y axes.



The first screen you'll see is the 'SELECT DEVICE TO MODIFY' screen.

You have two choices; choose to alter either the Stick or the Throttle axis.

Once you are in the 'STICK // AXIS MODIFICATION' screen, you'll see a raft of options. We'll go through them one by one.

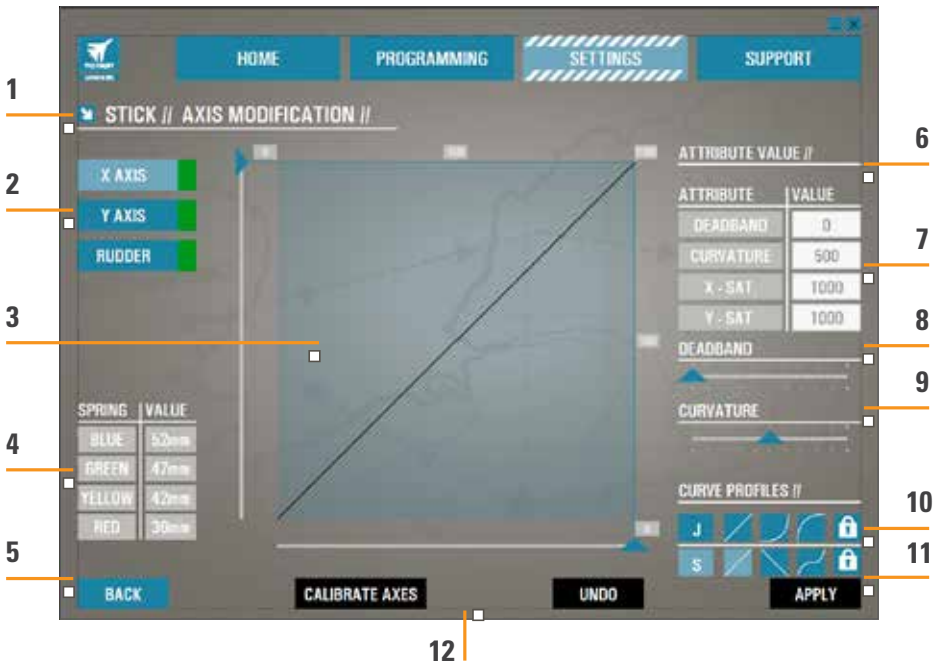

1. Name of the Part being Modified
2. Modifiable Axes
3. Manual Axis Adjustment and Test Area
4. Spring Values – for Reference when Changing Axis Data
5. Back Button
6. Physical Axis Adjustment Slider
7. Manual Axis Attribute Boxes
8. Deadzone Adjustment
9. Axis Curvature Adjustment
10. Pre-made Profiles
11. Apply Button
12. Undo Button

## 1. Name of the Part being Modified

This will either be the Stick or the Throttle unit for the X-56. If you wish to change the part that you're not currently on, use the back button (5) to go back to the selection screen.

## 2. Modifiable Axes

This shows a list of all modifiable axes. The Stick has three modifiable axes:

- X Axis
- Y Axis
- Rudder Axis

The Throttle unit has six modifiable axes:

- Left Throttle
- Right Throttle
- Rotary 1
- Rotary 2
- Rotary 3
- Rotary 4

## 3. Manual Axis Adjustment and Test Area

This area will show you how the current response curves / dead zones / saturation points are set up on the selected axis. You can also adjust the center deadzone, the range saturation, physical saturation, and the response curve on the selected axis. There is also a cross-hair which will show the physical position of the axis you are manipulating.

## 4. Spring Values

This is a reference section when you are adjusting the axes on the Stick. It will act as a guide for axis modification, and you may choose differing axis curves or deadzones depending on the Spring you have fitted to the Stick. If you are modifying the Throttle unit's axes you will not see this reference section.

## 5. Back Button

Takes you to the device selection screen.

## 6. Physical Axis Adjustment Slider

Allows the ends of the axes, the far left and far right on the X Axis or full up and full down on the Y Axis, to be moved inwards towards the center point. It is similar to setting up a deadzone at the far ends of your axes. on the Y-Axis to be moved inwards towards the center point, it is similar to setting up a deadzone at the far ends of your axis.

## 7. Manual Axis Attribute Boxes

This area allows you to input raw data to setup your deadband, curvature, range saturation, and physical saturation settings. This is very useful if you already have the data or a third-party source is supplying the data. For example, a forum post on how to setup the response curve for an F/A-18F.

## 8. Deadzone Adjustment

The deadzone slider will allow you to adjust the deadzone around the center point of the axis you currently have selected.

## 9. Axis Curvature Adjustment Slider

Shrinks the range of an axis. Instead of going from 0 to 65555, for example, we can shrink it to 300 to 62555.

## 10. Pre-made Profiles

We have included a set of predefined curves to select. This is to make it easier for those who do not wish to make their own curves. There are two different types of curves to choose from:

1. J-Curves – these curves will give you a single point of manipulation and are ideal for throttles and rotaries.
2. S-Curves – these curves will give you two points of manipulation and are ideal for setting up X and Y axes.

## 11. Apply Button

This button will save the curve that you are manipulating on the selected axis. Once saved, this axis will perform as saved, for all games, until the axis is adjusted and resaved or the reset button is used.

## 12. Undo Button

This button will turn the response curves on your currently selected axis back to their default state. This can be very useful when experimenting with curves and deadbands.

## Altering Axis Attributes

### Axis Status Notifications

You'll need to be aware of several notifications in the axis highlighter box when manipulating and applying axis data. On the left is a list of the current device's axes. The colors indicate the status of each axis.



Light Blue in the larger box indicates the currently selected axis.



Orange in the larger box indicates the axis isn't selected. Green in the smaller box indicates that the data on the settings page and the data on the device are in sync for this axis.



Yellow in the smaller box indicates that the data for this axis has been modified on the settings page but has not yet been synced to the device.



To sync data, click 'Apply' in the bottom right. The entire box will turn Yellow then start to fill up Green to indicate that the data on the settings page is being synced to the device. Once data is fully synced, the larger box will revert to Light Blue and the smaller box will stay Green.



When the Axis box turns Green, the data from the settings page saves to the physical device. The main Axis box will then turn Blue and the slash will turn to Green.

### Setting a Deadzone

To set a deadzone on an axis, whether it's an S-Curve or a J-Curve, simply move the deadzone slider (part 8). You will see the axis start to split from the middle in the manual adjust area. The deadzone will become larger as the slider moves farther.

### Setting a Response Curve

To set a response curve on an axis, whether it's an S-Curve or a J-Curve, simply move the curvature slider. On an S-Curve setting you will see the curve turn snake-like, which indicates curvature above and below the center point the axis.

On a J-Curve setting you will see the whole axis curve as the slider moves. You can also change the curvature of either curve by moving the points in the manual adjustment area (part 4). If you move the points in the area, 2 for an S-Curve and 1 for a J-Curve, then the curve will adjust to the new points.

### Setting an Axis Range

To set an axis range, simply move the Axis Range Adjustment Slider (part 5). This will shrink the data for that axis from the full negative side and from the full positive side. Now when you use the axis that you have just altered, the axis data output will only output up to the points that you have set in the settings.

## Setting a Physical Axis

To set the physical axis range on any axis, move the Physical Axis Adjustment Slider (part 6). Moving this slider will shrink the minimum and maximum range of the physical axis. After moving the sliders to set your axis, every time you move the physical axis you'll see that the minimum and maximum range has shrunk.

## Saving a Setting

To save settings so they're usable, click the 'Apply' Button in the bottom right-hand corner of the screen (part 13). Once you've hit 'Apply,' the axis icon (part 1) will turn Yellow, and progressively turn Green. A Green end segment and Blue main axis indicates saved data.

For more details on axis notification, please check the 'Axis Notifications' section.

## Support

Under the 'SUPPORT' tab you can perform a number of support-related activities.

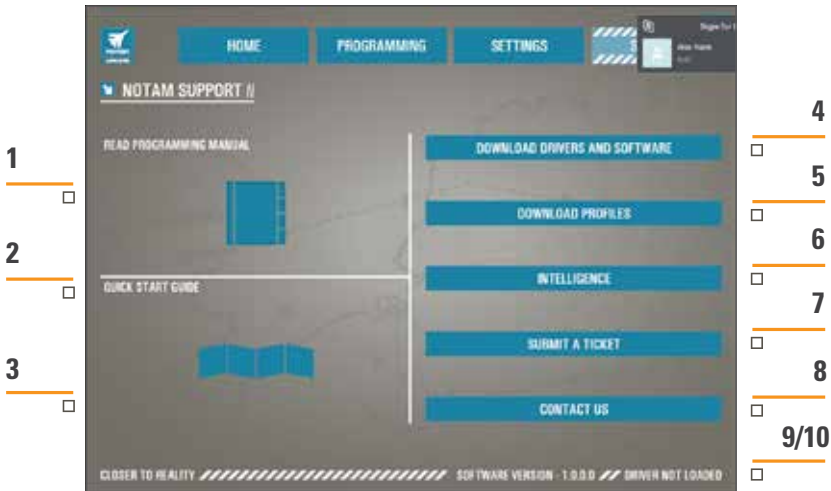

1. View online videos of the X-56 Rhino
2. View the Manual in PDF format
3. View the Quick Start Guide (QSG) in PDF format
4. Download the latest Drivers and Software
5. Download Profiles
6. Knowledgebase
7. Submit a Ticket
8. Contact Us
9. View the Software version
10. View the Driver version

**View Online Videos of the X-56 Rhino**

Clicking this icon will launch the X-56 YouTube® channel. A number of videos on this channel will highlight the X-56 Rhino's standout features.

**View the Manual in PDF Format**

Opens up a PDF version of this Manual.

**View the Quick Start Guide (QSG) in PDF Format**

Opens up a PDF version of the Quick Start Guide.

**Download latest Drivers and Software**

Clicking this link will open the X-56's Drivers and Software webpage. From here you can download the latest Drivers and Software for your X-56.

**Download Profiles**

Clicking this link will open the X-56 profiles web page, where you will find all the latest profiles for the X-56, ready for download and use on your PC.

**Knowledgebase**

Opens the X-56's FAQ web page, where you can find all of the most common questions and answers. If you're having a little difficulty with setup, try here first. You may avoid the hassle of contacting Tech Support.

**Submit a Ticket**

In the very unlikely event that you are having a problem with the X-56, please feel free to submit a Ticket to our world-class Tech Support team.

**Contact Us**

If you prefer to talk to our Tech Support team, or want to discuss another matter, clicking this link opens a webpage containing all contact info.

**Software Version**

The numbers listed here relate to the Software version you currently have installed. This is useful if you are looking to upgrade your Software to a later version.

**Driver Version**

The numbers listed here relate to the Driver version you currently have installed. This is useful if you are looking to upgrade your Drivers to later version.

## TROUBLESHOOTING

### **Q1 My computer is not recognizing the Pro Flight Controller, what's wrong?**

- A 1. Have you downloaded and installed the drivers from [www.saitek.com](http://www.saitek.com)?
- A 2. Check the cable connections. Unplug your controller and plug it back in, making certain that it is securely attached.
- A 3. If you're using front or top facing USB ports, try plugging into the back of the PC.
- A 4. If using a hub, make sure it's a powered hub.

### **Q2 Why doesn't the game I'm playing recognize my Pro Flight Controller?**

- A 1. Ensure that you have conducted the checks in Q1 [above].
- A 2. Does the game you are playing offer support for game controllers? Please refer to your game's manual, which should contain information regarding the use of game controllers. If it does not, you can use the powerful programming software to emulate the mouse and keyboard on your X-56 Rhino

### **Q3 One of the buttons or axes is not working on my controller.**

- A 1. Please test your product in the Game Controllers panel as mentioned in the early part of this manual.
- A 2. If you are still experiencing problems with the controller, please contact the tech support team at <http://support.madcatz.com/Tickets/Submit>

### **Q4 What can I do if my controller is missing a part?**

- A 1. Please contact the tech support team for assistance: <http://support.madcatz.com/Tickets/Submit>

### **Q5 In flight simulation games, like FSX, why doesn't my aircraft correctly respond to axes?**

- A 1. The X-56 stick and throttle units are independent units, therefore they both have an X Axis, a Y Axis, etc. It is a simple case of going into the controller settings for your simulation game and setting up the X-56 Rhino. For a more detailed overview on how to do this please visit our FAQ page: <http://support.madcatz.com>

### **Q6 How do I change the X-56's LED brightness?**

- A 1. Install the software to find a brightness slider under the SETTINGS tab.

### **Q7 Why are my axes off center or moving erratically?**

- A 1. Please visit the FAQ page in the support section of the Saitek webpage to find simple instructions on how to reset the calibration. All addresses are listed within the Technical Support area of this manual.



## TECHNICAL SUPPORT

Can't get started? Don't worry; we're here to help you! Nearly all the products that are returned to us as faulty are not faulty at all - they have just not been installed properly. If you experience any difficulty with this product, please first visit our website <http://support.madcatz.com>. The technical support area will provide you with all the information you need to get the most out of your product and should solve any problems you might have. If you do not have access to the Internet, or if the website cannot answer your question, please contact your local Mad Catz Technical Support Team. We aim to offer quick, comprehensive, and thorough technical support to all our users so, before you call, please make sure you have all the relevant information at hand.

## FCC & IC WARNING

This device complies with part 15 of the FCC Rules and Industry Canada license-exempt RSS standard (s). Operation is subject to the following two conditions: (1) This device may not cause harmful interference, and (2) this device must accept any interference received, including interference that may cause undesired operation.

Any changes or modifications not expressly approved by the party responsible for compliance could void the user's authority to operate the equipment.

### FCC Radiation Exposure Statement:

This equipment complies with FCC radiation exposure limits set forth for an uncontrolled environment.

This transmitter must not be co-located or operating in conjunction with any other antenna or transmitter.

### IC RF Exposure Statement:

The device meets the exemption from the routine evaluation limits in section 2.5 of RSS 102 and compliance with RSS-102 RF exposure, users can obtain Canadian information on RF exposure and compliance.

Under Industry Canada regulations, this radio transmitter may only operate using an antenna of a type and maximum (or lesser) gain approved for the transmitter by Industry Canada. To reduce potential radio interference to other users, the antenna type and its gain should be so chosen that, the equivalent isotropically radiated power (e.i.r.p.) is not more than that necessary for successful communication.

**Saitek®**

 **CLOSER TO REALITY™**