

GV-Fisheye IP Camera H.264

User's Manual



Before attempting to connect or operate this product,
please read these instructions carefully and save this manual for future use.

FER12203V102-A-EN



© 2016 GeoVision, Inc. All rights reserved.

Under the copyright laws, this manual may not be copied, in whole or in part, without the written consent of GeoVision.

Every effort has been made to ensure that the information in this manual is accurate. GeoVision, Inc. makes no expressed or implied warranty of any kind and assumes no responsibility for errors or omissions. No liability is assumed for incidental or consequential damages arising from the use of the information or products contained herein. Features and specifications are subject to change without notice.

Note: No memory card slot or local storage function for Argentina.

GeoVision, Inc.
9F, No. 246, Sec. 1, Neihu Rd.,
Neihu District, Taipei, Taiwan
Tel: +886-2-8797-8377
Fax: +886-2-8797-8335
<http://www.geovision.com.tw>

Trademarks used in this manual: *GeoVision*, the *GeoVision* logo and GV series products are trademarks of GeoVision, Inc. *Windows* and *Windows XP* are registered trademarks of Microsoft Corporation.

May 2016

Preface

Welcome to the *GV-Fisheye IP Camera User's Manual*.

The GV-Fisheye IP Camera has the following models with different resolutions. This Manual is designed for the following models and firmware versions:

Model	Model Number	Firmware Version
Fisheye Camera	GV-FE2301	V3.0
	GV-FE4301	
	GV-FE3402 / 3403	V3.03
	GV-FE5302 / 5303	V3.0
Fisheye Rugged Camera	GV-FER3402 / 3403	V3.03
	GV-FER5302 / 5303	V3.0
	GV-FER12203	V1.02
IR Fisheye Camera	GV-UNFE2503	V3.06

Note:

1. To upgrade the camera firmware from V2.07 or earlier to the latest version, back up the files in the camera's memory card first before the upgrade and it is required to re-format the memory card after the upgrade.
 2. Starting from V3.0, GV-Fisheye IP Camera (except GV-FER12203) supports recording to NAS devices using the Network Neighborhood settings.
-

Contents

Naming and Definition	vii
Note for Connecting to GV-System / GV-VMS	viii
Note for Recording	ix
Note for USB Storage and WiFi Adapter	x
Note for Installing Camera.....	xi
Note for Waterproofing Failures (GV-UNFE2503).....	xiii
Chapter 1 Introduction	1
1.1 Key Features	2
1.2 Packing List.....	5
1.3 System Requirement.....	12
1.4 Optional Accessories.....	13
1.5 Physical Description	14
1.5.1 GV-FE2301 / 4301	14
1.5.2 GV-FE3402 / 3403 / 5302 / 5303	16
1.5.3 GV-FER3402 / 3403 / 5302 / 5303.....	17
1.5.4 GV-FER12203.....	20
1.5.5 GV-UNFE2503	21
1.6 Installation	22
1.6.1 Hard Ceiling Mount	23
General Hard-Ceiling Mount	23
GV-FER12203.....	27
1.6.2 In-Ceiling Mount.....	31
General In-Ceiling Mount	31
GV-UNFE2503	34
1.6.3 Standard Wall Mount and Ground Mount.....	39
1.6.4 Ground Mount	39
1.7 Connecting the GV-Fisheye Camera.....	40
1.7.1 GV-FE2301 / 4301	40
1.7.2 GV-FE3402 / 3403 / 5302 / 5303	42
1.7.3 Connecting PoE Converter and IR LED Ring for GV-FE3403 / 5303	43
1.7.4 GV-FER3402 / 3403 / 5302 / 5303.....	46

1.7.5	GV-FER12203.....	48
Chapter 2	Getting Started	49
2.1	Installing on a Network	49
2.1.1	Checking the Dynamic IP Address.....	50
2.1.2	Assigning an IP Address	52
2.1.3	Configuring the Wireless Connection	54
2.2	Configuring the Basics.....	57
Chapter 3	Accessing the Camera.....	58
3.1	Accessing Your Surveillance Images	58
3.2	Functions Featured on the Main Page	59
3.2.1	The Live View Window	60
3.2.2	Fisheye View	63
3.2.3	The Control Panel of the Live View Window	67
3.2.4	Snapshot of a Live Video	71
3.2.5	Video Recording.....	71
3.2.6	Wide Angle Lens Dewarping	72
3.2.7	Picture-in-Picture and Picture-and-Picture View	73
3.2.8	Object Tracking	75
3.2.9	Alarm Notification	77
3.2.10	Video and Audio Configuration	79
3.2.11	Remote Configuration	81
3.2.12	Camera Name Display	81
3.2.13	Image Enhancement	81
3.2.14	I/O Control.....	82
3.2.15	Visual Automation	83
3.2.16	Network Status.....	84
Chapter 4	Administrator Mode	85
4.1	Video & Motion	87
4.1.1	Video Settings	88
4.1.2	Motion Detection	95
4.1.2	Motion Detection	95
4.1.3	Privacy Mask.....	97

4.1.4	Text Overlay	98
4.1.5	Tampering Alarm.....	99
4.1.6	Visual Automation	101
4.2	I/O Control	102
4.2.1	Input Settings	102
4.2.2	Output Settings	103
4.3	Events & Alerts.....	104
4.3.1	E-mail	104
4.3.2	FTP	106
4.3.3	Center V2	109
4.3.4	Vital Sign Monitor	111
4.3.5	Backup Center	113
4.3.6	Video Gateway / Recording Server.....	115
4.3.7	ViewLog Server.....	117
4.3.8	RTSP/ONVIF.....	118
4.4	Monitoring.....	120
4.5	Recording Schedule	122
4.5.1	Recording Schedule Settings.....	122
4.5.2	I/O Monitoring Settings.....	123
4.6	Remote ViewLog	124
4.7	Network	125
4.7.1	LAN	125
4.7.2	Wireless Client Mode	127
4.7.3	Advanced TCP/IP.....	129
4.7.4	UMTS Settings	133
4.7.5	IP Filtering	135
4.7.6	SNMP Setting.....	136
4.8	Management.....	137
4.8.1	Date and Time Settings.....	137
4.8.2	Storage Settings.....	139
4.8.3	User Account.....	144
4.8.4	Log Information	145
4.8.5	Tools	147
4.8.6	Language	149

Chapter 5 Recording and Playback150

5.1	Recording	150
5.2	Playback.....	151

5.2.1	Playback from the Memory Card.....	151
5.2.2	Playback over Network	156
5.2.3	Access to the Recorded Files through FTP Server	157
5.2.4	Playback of Daylight Saving Time Events.....	158

Chapter 6 Advanced Applications159

6.1	Upgrading System Firmware	159
6.1.1	Using the Web Interface.....	161
6.1.2	Using the GV-IP Device Utility	162
6.2	Backing Up and Restoring Settings.....	164
6.2.1	Backing Up the Settings.....	164
6.2.2	Restoring the Settings.....	165
6.3	Restoring to Factory Default Settings.....	166
6.3.1	Using the Web Interface.....	166
6.3.2	Directly on the Camera	166
6.4	Changing Password	170
6.5	Verifying Watermark.....	172
6.5.1	Accessing AVI Files	172
6.5.2	Running Watermark Proof.....	172
6.5.3	The Watermark Proof Window	173
6.6	Downloading Videos from the Micro SD Card.....	174
6.6.1	Installing the GV-SDCardSync Utility	174
6.6.2	The GV-SDCardSync Utility Window	177

Chapter 7 DVR Configurations178

7.1	Setting Up IP Cameras on GV-System	180
7.1.1	Customizing the Basic Settings on GV-System	183
7.2	Setting Up IP Cameras on GV-VMS.....	184
7.3	Remote Monitoring with Multi View	187
7.3.1	Connecting to the IP Camera.....	187
7.4	Remote Monitoring with E-Map	188
7.4.1	Creating an E-Map for the IP Camera.....	188
7.4.2	Connecting to the IP Camera.....	189

Chapter 8 CMS Configurations.....190

8.1	Center V2	190
-----	-----------------	-----

8.2 Vital Sign Monitor	193
8.3 Dispatch Server	194

Appendix196

A. Settings for Internet Explore 8 or later	196
B. RTSP Protocol Support	197
C. The Supported Mobile Broadband Devices.....	198
D. The CGI Command	199
E. Supported Firmware for Flash Memory	200
F. How to Remotely Reboot IP Cameras via FTP.....	201

Naming and Definition

GV-System	GeoVision Analog and Digital Video Recording Software. The GV-System also refers to Multicam System , GV-NVR System , GV-Hybrid DVR System and GV-DVR System at the same time.
GV-VMS	GeoVision Video Management System for IP cameras.

Note for Connecting to GV-System / GV-VMS

The GV-Fisheye IP Camera is designed to work with GV-System / GV-VMS, a video management system. Note the following when the camera is connected to GV-System / GV-VMS:

1. By default, the images are recorded to the memory card inserted in the GV-Fisheye IP Camera.
2. Once the camera is connected to the GV-System / GV-VMS, the resolution set on the GV-System / GV-VMS will override the resolution set on the camera's Web interface. You can only change the resolution settings through the Web interface when the connection to the GV-System / GV-VMS is interrupted.

Note for Recording

1. By default, the images are recorded to the memory card inserted in the GV-Fisheye IP Camera. Make sure the **Write recording data into local storage** option (see *4.1.1 Video Settings*) is enabled. If this option is disabled, the camera will stop recording to the memory card while the live view is accessed through Web browsers or other applications.
2. Mind the following when using a memory card for recording:
 - Recorded data on the memory card can be damaged or lost if the data are accessed while the camera is under physical shock, power interruption, memory card detachment or when the memory card reaches the end of its lifespan. No guarantee is provided for such causes.
 - The stored data can be lost if the memory card is not accessed for a long period of time. Back up your data periodically if you seldom access the memory card.
 - Memory cards are expendable and their durability varies according to the conditions of the installed site and how they are used. Back up your data regularly and replace the memory card annually.
 - To avoid power outage, it is highly suggested to apply a battery backup (UPS).
 - For better performance, it is highly suggested to use Micro SD card of MLC NAND flash, Class 10.
 - Replace the memory card when its read/write speed is lower than 6 MB/s or when the memory card is frequently undetected by the camera.
3. It is recommended to use memory cards of the following setting and specifications:
 - Apply a battery backup (UPS) to avoid power outage.
 - Use Micro SD card of MLC NAND flash, Class 10 for better performance.

Note for USB Storage and WiFi Adapter

Mind the following limitations and requirements for using USB storage and GV-WiFi Adapter:

1. The USB hard drive must be of 2.5" or 3.5", version 2.0 or above.
2. The USB hard drive's storage capacity must not exceed 2TB.
3. USB flash drives and USB hubs are not supported.
4. External power supply is required for the USB hard drive.
5. To connect a GV-WiFi Adapter, make sure it is connected before the camera is powered on.

Note for Installing Camera

When installing **GV-FER outdoor models**, be sure that:

1. The camera is set up above the junction box to prevent water from entering the camera along the cables.

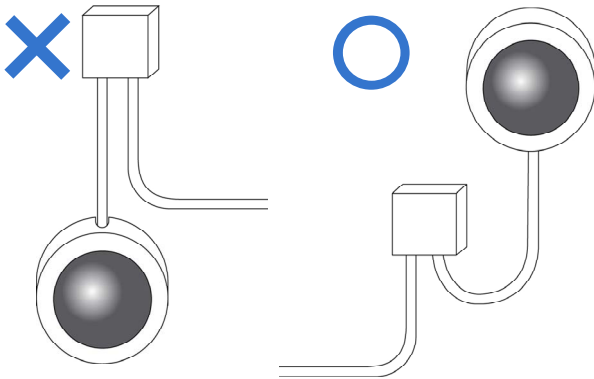

2. Any PoE, power, audio and I/O cables are waterproofed using waterproof silicon rubber or the like.

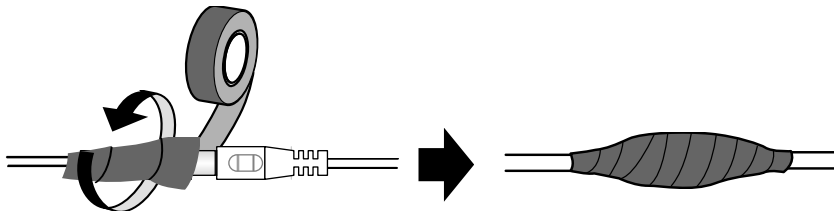

3. The screws are tightened and the cover is in place after opening the camera cover.



4. The silica gel bag loses its effectiveness when the dry camera is opened. To prevent the lens from fogging up, use the supplied adhesive tap and replace the silica gel bag every time you open the camera, and conceal the gel bag in camera within 2 minutes of exposing to open air.

When installing **GV-FE indoor models**, be sure to:

- Keep the indoor camera shielded from rain and moisture.

When installing **GV-FE or GV-FER models with IR LED rings**, be sure that:

- An operating IR LED ring may reach high temperatures of up to 60°C (140°F). Disconnect the power supply and allow the IR LED ring to cool down before handling the device.



Note for Waterproofing Failures (GV-UNFE2503)

To avoid waterproofing failures for GV-UNFE2503, do not open the two screws on the camera lens.



Chapter 1 Introduction

The fisheye camera allows you to monitor all angles of a location using just one camera. It can be installed to the ceiling, wall, wall corner and pole. The distorted hemispherical image of the fisheye camera will be converted into the conventional rectilinear projection.

Without installing any software, you can watch live view and utilize functions such as motion detection, privacy mask, and alert notification through the Web interface. In addition, GV-Fisheye IP Camera seamlessly integrates with the GV-System / GV-VMS, providing advanced monitoring and video management features.

The following GV-Fisheye Cameras are available:

Models	Type	Description
GV-FE2301 / 4301	Indoor	2 MP / 4 MP
GV-FE3402 / 5302		3 MP WDR Pro / 5 MP
GV-FE3403 / 5303		3 MP WDR Pro / 5 MP, IR LED ring
GV-FER3402 / 5302	Outdoor	3 MP WDR Pro / 5 MP, IP67, IK10+ for metal casing
GV-FER3403 / 5303		3 MP WDR Pro / 5 MP, IR LED ring, IP67, IK10+ for metal casing
GV-FER12203		12 MP, IR LED, IP 67, IK10+ for metal casing
GV-UNFE2503		2 MP Super Low Lux, IR LED ring, IP67

1.1 Key Features

- Image sensor

Camera Model	Image Sensor
GV-FE2301 GV-FE4301 GV-FE5302 / 5303 GV-FER5302 / 5303	1/2.5" progressive scan CMOS
GV-FE3402 / 3403 GV-FER3402 / 3403	1/3.2" progressive scan CMOS
GV-FER12203	1/1.7" progressive scan CMOS
GV-UNFE2503	1/2.8" progressive scan super low lux CMOS

- Dual streams from H.264 or MJPEG
- Frame rate

Camera Model	Frame Rate
GV-FE2301	Up to 15 fps at 1440 x 1376
GV-FE3402 / 3403 GV-FER3402 / 3403	Up to 15 fps at 2048 x 1536
GV-FE4301	Up to 15 fps at 2048 x 1944
GV-FE5302 / 5303 GV-FER5302 / 5303	Up to 10 fps at 2560 x 1920
GV-FER12203	Up to 15 fps at 4000 x 3000
GV-UNFE2503	Up to 30 fps at 1920 x 1080

- Day and night function

Camera Model	Day / Night function
GV-FE2301 / 4301	Electronic
GV-FE3402 / 3403 GV-FE5302 / 5303 GV-FER3402 / 3403 GV-FER5302 / 5303 GV-FER12203 GV-UNFE2503	Removable IR-cut filter

- Effective distance of IR LED
 - Up to 10 m / 32.81 ft (GV-FE3403 / 5303, GV-FER3403 / 5303 and GV-UNFE2503)
 - Up to 30 m / 98.43 ft (GV-FER12203)
- Wide Dynamic Range
 - WDR for GV-FE5302 / 5303, GV-FER5302 / 5303 and GV-UNFE2503
 - WDR Pro for GV-FE3402 / 3403 and GV-FER3402 / 3403
- Ingress protection
 - IP67 rating (GV-FER3402 / 3403 / 5302 / 5303 / 12203 and GV-UNFE2503)
- Vandal Resistance Rating
 - IK10+ for metal casing (GV-FE3402 / 3403 / 5302 / 5303 and GV-FER3402 / 3403 / 5302 / 5303 / 12203)
- Intelligent IR (GV-FER12203 and GV-UNFE2503)
- Low lux enhancement (GV-FER12203 and GV-UNFE2503)
- Built-in micro SD card slot (SD/SDHC) for local storage
- Audio
 - Two-way audio (Except GV-UNFE2503)
 - One-way audio (GV-UNFE2503)
- Mini USB slot for WiFi adapter or USB hard drive (GV-FE3402 / 3403 / 5302 / 5303)
- USB slot for WiFi adapter (GV-FER12203)
- One sensor input and alarm output (GV-FE2301 / 4301 and GV-FER12203)
- No mechanical moving parts
- Provides 360° and 180° panorama view
- Different angle of view controllable by multiple users at the same time

- Playback from any view angle and zoom level
- Digital Object Tracking
- Virtual PTZ function
- Auto Pan function
- 2D noise reduction
- 3D noise reduction (GV-UNFE2503)
- Defog (Except GV-FER12203)
- Privacy mask
- Visual automation
- Tampering alarm
- Text overlay
- 31 languages on Web interface
- ONVIF (Profile S) conformant
- Recording assigned by GV-Edge Recording Manager
- More storage option - [NAS](#)

Note: GV-FER12203 does not support connection with NAS servers.

1.2 Packing List

GV-FE2301 / 4301

- Fisheye Camera



- Support Bracket x 3



- Camera Cover (Hard Ceiling Mount)



- Camera Cover (In-Ceiling Mount)



- Screw (Hard Ceiling Mount) x 3



- Screw (In-Ceiling Mount) x 3



- Torx Wrench



- Plastic Screw Anchor x 3



- Installation Sticker
- For GV-FE2301 / 4301 only:
 - 3-Pin or 2-Pin Terminal Block
 - DC 12V Power Adapter
- GV-IPCAM H.264 Software DVD
- GV-NVR Software DVD
- Warranty Card

GV-FE3402 / 5302 and GV-FE3403 / 5303

- Fisheye Camera



- Support Bracket x 3



- Camera Cover (Hard Ceiling Mount)



- Camera Cover (In-Ceiling Mount)



- Screw (Hard Ceiling Mount) x 3



- Screw (In-Ceiling Mount) x 3



- Torx Wrench



- Plastic Screw Anchor x 3



- Mini USB Extension Cable



- IR LED Ring (GV-FE3403 / 5303 only)



- PoE Converter set (including 1 module, 1 DC Power Y-cable, 1 RJ-45 cable and 3 PoE Screws) (GV-FE3403 / 5303 only)



- Installation Sticker

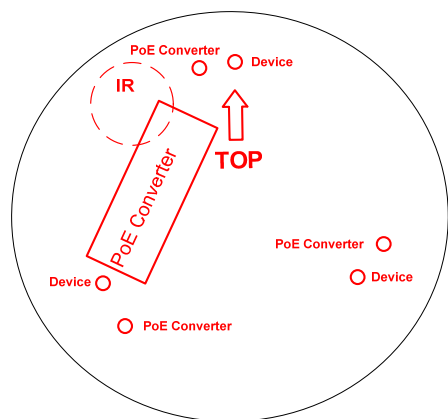

- Power Adapter
- GV-IPCAM H.264 Software DVD
- GV-NVR Software DVD
- GV-Fisheye IP Dome Hardware Installation Guide
- Warranty Card

Note: The power adapter can be excluded upon request.

GV-FER3402 / 5302 and GV-FER3403 / 5303

- Fisheye Camera



- Support Bracket x 3



- Camera Cover (Hard Ceiling Mount)



- Camera Cover (In-Ceiling Mount)



- Screw (Hard Ceiling Mount) x 3



- Screw (In-Ceiling Mount) x 3



- Torx Wrench



- Plastic Screw Anchor x 3



- IR LED Ring (GV-FER3403 / 5303 only)



- Waterproof Rubber



- Power Cable



- Terminal Block x 2

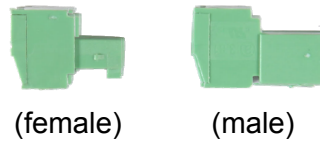

- IR Power Adapter (DC 12V, 3.5A, GV-FER3403 / 5303 only)



- Installation Sticker

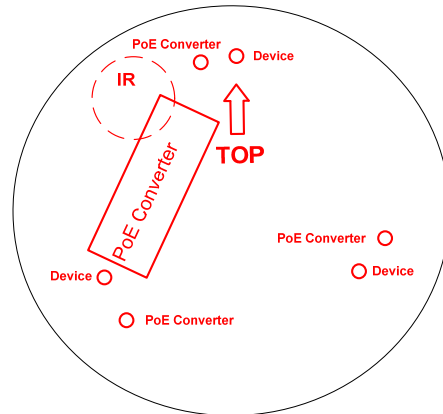

- Silica Gel Bag and Adhesive Tape x 2
- Power Adapter (DC 12V, 1.25A)
- GV-IPCAM H.264 Software DVD
- GV-NVR Software DVD
- GV-Fisheye IP Dome Hardware Installation Guide
- Warranty Card
- Cable Connector

Note: The power adapter can be excluded upon request.

GV-FER12203

- Fisheye Camera



- Plate Screw x 3



- Torx Wrench



- Data Cable



- Installation Sticker

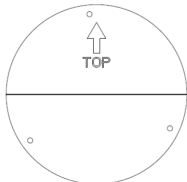

- Silica Gel Bag x 2



- Power Adapter
- GV-IPCAM H.264 Software DVD
- GV-NVR Software DVD
- Warranty Card

- Back Plate



- Plastic Screw Anchor x 3



- RJ-45 Connector



- Terminal Block



- Ruler

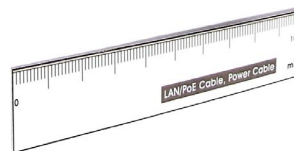

Note: The power adapter can be excluded upon request.

GV-UNFE2503

- IR Fisheye Camera



- Installation Sticker

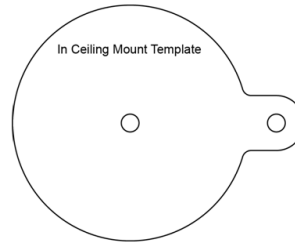

- Main Body Adhesive Tape



- Main Body Mount



- M2 Screw



- M3 Screw x 2



- Warning Label

- GV-NVR Software DVD

- GV-IPCAM H.264 Software DVD

- Warranty Card

1.3 System Requirement

To operate the camera through a web browser, make sure your PC has good network connection, and meet the following system requirement:

OS	64-bit	Windows 7 / 8 / 8.1 / Server 2008 R2 / Server 2012 R2
GV-VMS		V14.1 or later
GV-System Version		V8.5.9.0 with patch files or later versions
Browser		<ul style="list-style-type: none"> • Internet Explorer 7.x or later • Firefox • Google Chrome • Safari

Note:

1. If you are using Microsoft Internet Explorer 8.0 or later, additional settings are required. Refer to *Settings for Internet Explorer 8 or later* in Appendix A.
 2. When using non-IE browsers,
 - a. The following functions are not supported: Motion Detection, Tampering Alarm, Visual Automation, Text Overlay, and Two-Way Audio. To see the functions available on live view windows using non-IE browsers, see *Figure 3-4*.
 - b. RTSP streaming must be enabled. By default, RTSP streaming is enabled. See *4.3.8 RTSP* to see more details on RTSP settings.
-

To access GV-FER12203 images, the following PC specifications should be met:

CPU	Intel Core i5-4670, 3.40 GHz
Memory	DDR3 8 GB RAM
On Board Graphics	Intel HD Graphics 4600 (Versions of driver from year 2014 or later required)

1.4 Optional Accessories

Optional devices can expand the capabilities and versatility of your GV-Fisheye Camera. Contact your dealer for more information.

Name	Details
GV-PA191 Power over Ethernet (PoE) Adapter	The GV-PA191 is a Power over Ethernet (PoE) adapter designed to provide power to the IP device through a single Ethernet cable.
GV-Mount Accessories	The GV-Mount Accessories provides a comprehensive lineup of accessories for installation on ceiling, wall and pole. For details, see <i>GV-Mount Accessories Installation Guide</i> online.
GV-WiFi Adapter	The GV-WiFi Adapter is a plug-and-play device that provides WiFi connectivity to GV-IP Cameras through a mini USB port. This product complies with IEEE 802.11 b/g/n (Draft 3.0) standards for wireless networking.
GV-POE Switch	The GV-POE Switch is designed to provide power along with network connection for IP devices. The GV-POE Switch is available in various models with different numbers and types of ports.
Power Adapter	Contact your sales representative for the countries and areas supported.

1.5 Physical Description

1.5.1 GV-FE2301 / 4301

To access the Default button, LED indicators and micro SD card slot, unscrew the screws indicated below and then remove the camera cover.



Figure 1-1: GV-FE2301 / 4301

You can now access the Load Default button, LED indicators, and the micro SD card slot.

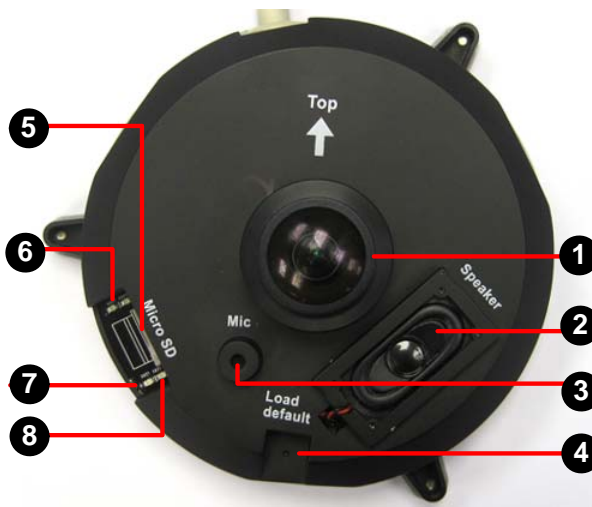

Figure 1-2: GV-FE2301 / 4301

No.	Name	Function
1	Lens	Receives image inputs.
2	Speaker	Talks to the surveillance area from the local computer.
3	Microphone	Receives the sound from the camera.
4	Default Button	Resets all configurations to default factory settings. See 6.3 <i>Restoring to Factory Default Settings</i> .
5	Micro SD Card Slot	Inserts a micro SD / SDHC memory card to store recorded data.
6	Network status LED	Indicates the network status.
7	Power status LED	Indicates whether the camera is powered on or off.
8	System status LED	Indicates whether the system is booted successfully or not.

Note: SDXC and UHS-I card types are not supported.

1.5.2 GV-FE3402 / 3403 / 5302 / 5303

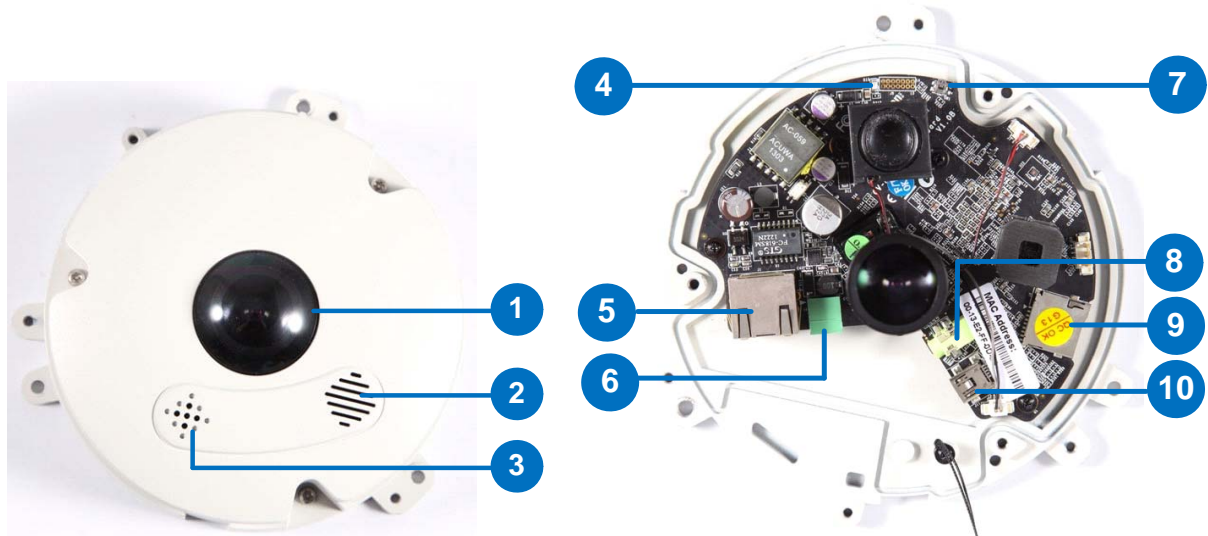

Figure 1-3

No.	Name	Function
1.	Lens	Receives image inputs.
2.	Speaker	Talks to the surveillance area from the local computer.
3.	Microphone	Receives the sound from the camera.
4.	Status LED	Indicates whether the device is booted successfully or not.
5.	LAN / PoE	Connects to a 10/100 Ethernet or PoE.
6.	Terminal Block	Connects to power.
7.	Default Button	Resets all configurations to default factory settings. See 6.3 <i>Restoring to Factory Default Settings</i> .
8.	Audio Out	Connects to an external speaker for broadcast.
9.	Micro SD Card Slot	Inserts a micro SD / SDHC memory card to store recorded data.
10.	Mini USB Slot	Connects to a GV-WiFi Adapter or a USB hard drive for external storage.
<p>Note: SDXC and UHS-I card types are not supported.</p>		

1.5.3 GV-FER3402 / 3403 / 5302 / 5303

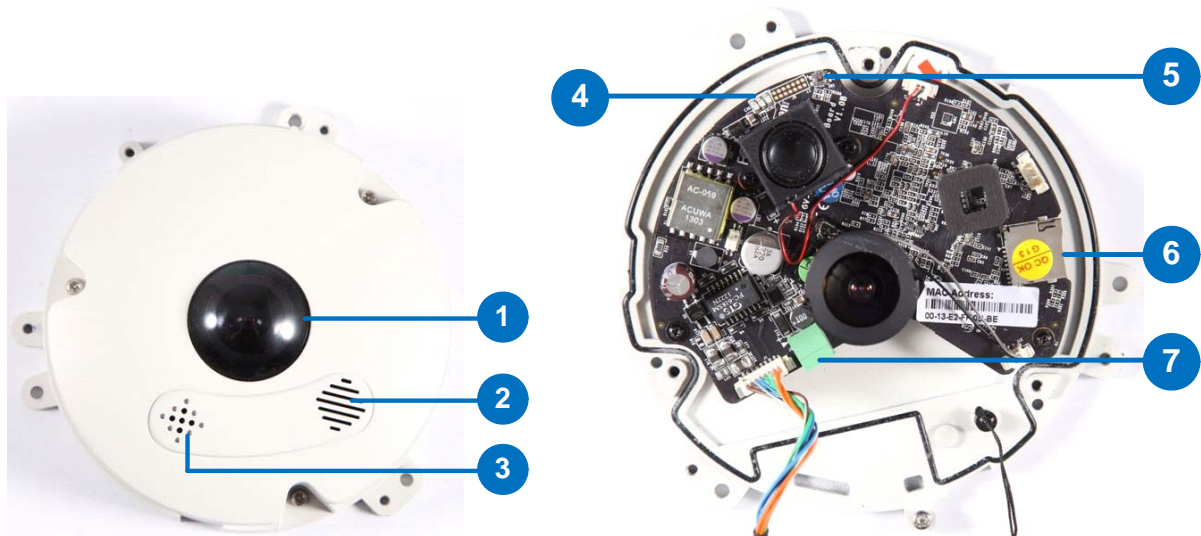

Figure 1-4

No.	Name	Function
1.	Lens	Receives image inputs.
2.	Speaker	Talks to the surveillance area from the local computer.
3.	Microphone	Receives the sound from the camera.
4.	LEDs	See the table below for details.
5.	Default Button	Resets all configurations to default factory settings. See 6.3 <i>Restoring to Factory Default Settings</i> .
6.	Micro SD Card Slot	Inserts a micro SD / SDHC memory card to store recorded data.
7.	Terminal Block	Connects to power.

Note: SDXC and UHS-I card types are not supported.

Note: For GV-FER3402 / 3403 / 5302 / 5303, a silica gel bag is attached to the inside of the camera cover. The silica gel loses effectiveness after you open the camera cover. To prevent the lens from fogging up, it is highly recommended to replace the silica gel bag every time you open the camera. To replace the silica gel bag, use the supplied adhesive tape to attach a new silica gel bag and fasten the camera cover within 2 minutes of opening the silica gel bag package.



LED Indicators

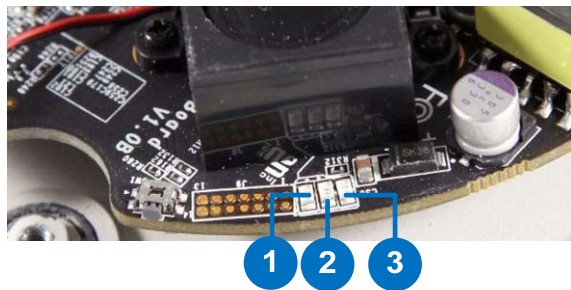

Figure 1-5

No.	Name	Function
1.	Link	Turns on when network is connected.
2.	ACT	Turns on when data are being transmitted or received.
3.	Status	Turns on when the device is ready.

PoE Cable

For GV-FER3402 / 3403 / 5302 / 5303, the PoE connector may be one of the following types:

Type 1

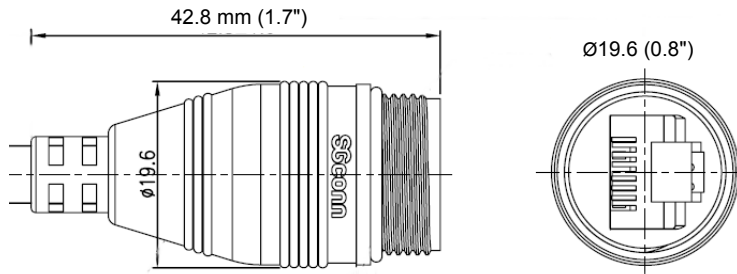

Type 2

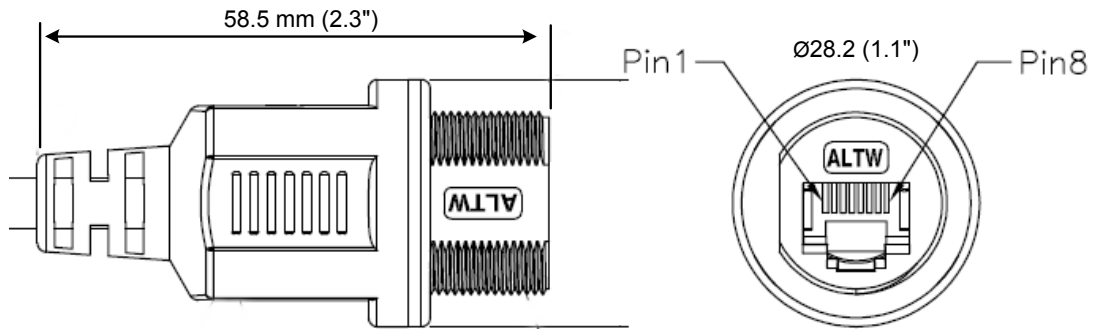

1.5.4 GV-FER12203

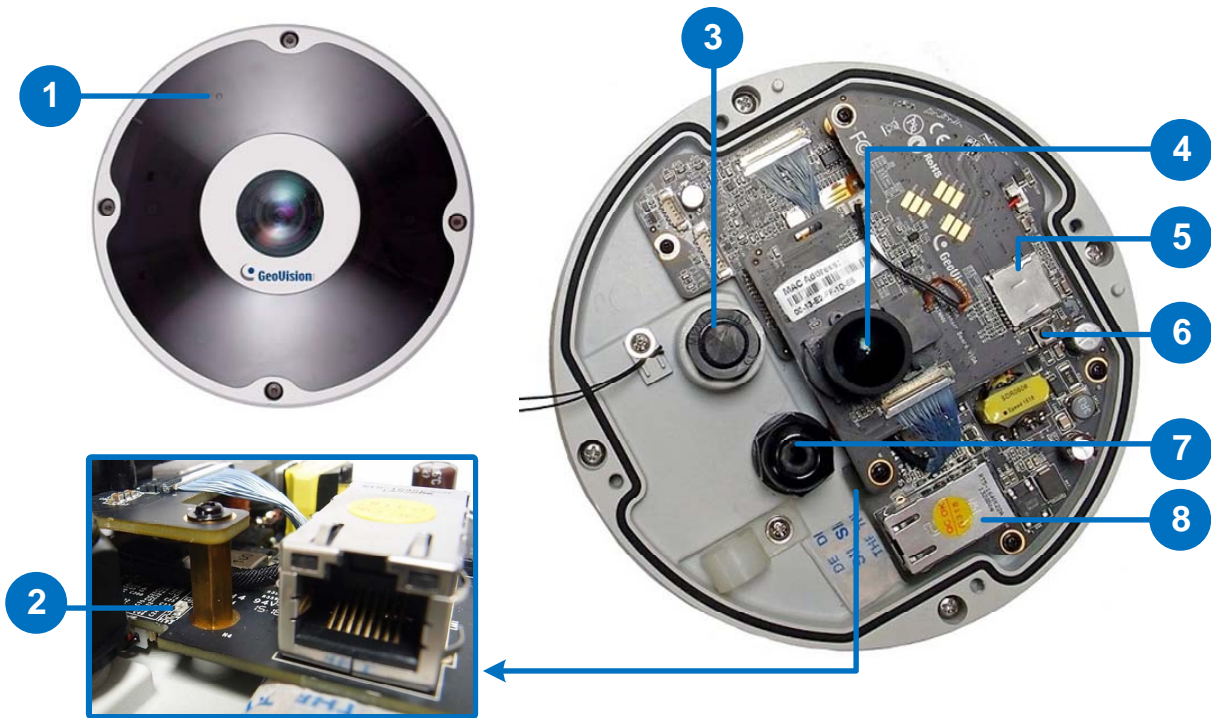

Figure 1-6

No.	Name	Function
1.	Microphone	Receives the sound from the camera.
2.	Status LED	Flashes when the camera is powering on and loading default settings.
3.	Data Cable Connector	Waterproofs the data cable.
4.	Lens	Receives image inputs.
5.	Micro SD Card Slot	Inserts a micro SD (SDHC /SDXC) memory card to store recorded data.
6.	Default Button	Resets all configurations to default factory settings. See <i>6.3 Restoring to Factory Default Settings</i> .
7.	LAN / PoE Connector	Waterproofs the Ethernet cable.
8.	LAN / PoE	Connects to a 10/100/1000 Ethernet or PoE.

Note: A silica gel bag is attached under the LAN / PoE port. The silica gel loses effectiveness after you open the camera cover. To prevent the lens from fogging up, it is highly recommended to replace the silica gel bag every time you open the camera. To replace the silica gel bag, use the supplied adhesive tape to attach a new silica gel bag and fasten the camera cover within 2 minutes of opening the silica gel bag package.

1.5.5 GV-UNFE2503



Figure 1-7

No.	Name	Function
1	Lens	Receives images.
2	Microphone	Receives sounds.
3	IR LED	Provides infrared illumination under low-light situations.
4	RJ12 Cable	Connects the camera lens and main body.
5	IR LED Power Connector	Connects the IR LED power cable.
6	Camera Ring	Fastens the camera to the desired surface.
7	RJ12 Port	Use the camera's RJ12 cable to connect the camera lens and main body.
8	RJ12 Status LED	Turns on (green) when the camera lens and main body are connected.
9	PoE	Connects to a PoE adapter.
10	Status LED	Turns on (green) when the system is ready.
11	Memory Card Slot	Inserts a micro SD card (SD/SDHC, version 2.0, Class 10) to store recording data.
12	Default Button	Restores the camera to factory default. For details, see 6.3 Restoring to Factory Default Settings: GV-UNFE2503.

1.6 Installation

The fisheye camera is designed to be mounted on the ceiling, wall or ground. There are two ways to mount the camera on the ceiling, **Hard Ceiling Mount** and **In-Ceiling Mount**. Make sure the ceiling has enough strength to support the fisheye camera.

Note: To re-focus your camera, follow the instruction below. However, it is only recommended to re-focus your camera when the live view is blurry.

- GV-FE2301 / 4301: Loosen the indicated screw and manually adjust the focus ring with your fingers.



- GV-FE3402 / 3403 / 5302 / 5303 and GV-FER3402 / 3403 / 5302 / 5303 / 12203: Manually adjust the focus ring with your fingers.

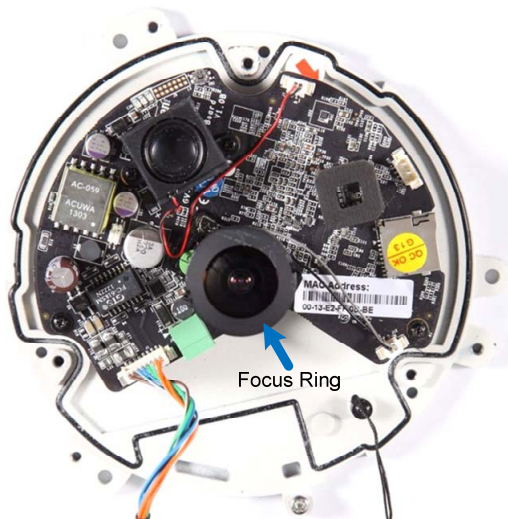

1.6.1 Hard Ceiling Mount

In this section, we introduce two types of hard-ceiling mounts: General Hard-Ceiling Mount and GV-FER12203.

General Hard-Ceiling Mount



Without IR LED Ring



With IR LED Ring

Note:

1. This hard-ceiling mount is not applicable to GV-FER12203 and GV-UNFE2503. For GV-UNFE2503 mounting, see [1.6.2 In-Ceiling Mount](#).
 2. To connect wires, cables and the IR LED ring, see [3. Connecting the Camera in the Quick Start Guide](#).
-

1. Place the installation sticker on the ceiling board. The 3 red dots indicate the location of the screws. To install GV-Fisheye Camera with PoE converter (GV-FE3403 / 5303), drill the 3 holes and the rectangle block indicated as “PoE Converter”; to install GV-Fisheye Camera only with the IR LED ring (GV-FE3403 / 5303 and GV-FER3403 / 5303), drill the 3 holes indicated as “Device” and the circle indicated as “IR”.

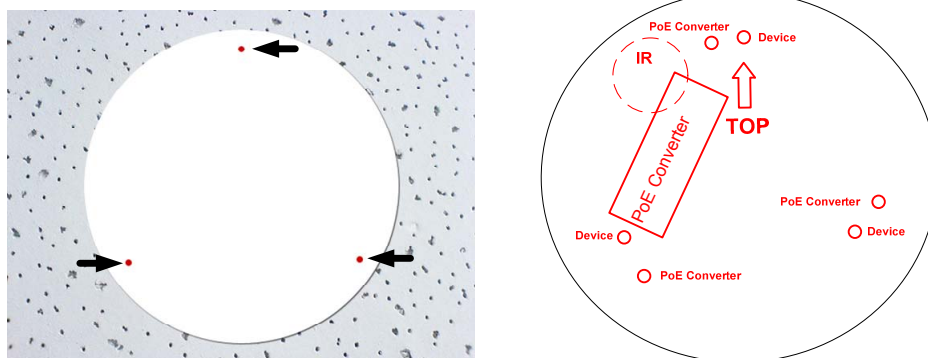

Figure 1-8

2. At the 3 red dots, drill a hole slightly smaller than the plastic screw anchors provided.
3. Insert the 3 plastic screw anchors in the drilled holes.
4. Secure the fisheye camera with the 3 hard ceiling mount screws provided.



Figure 1-9

5. For outdoor GV-Fisheye Cameras (GV-FER3402 / 3403 / 5302 / 5303), install the supplied cable connector to waterproof the cable. You should have 2 components:

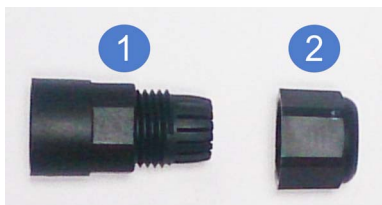

Figure 1-10

- a. Prepare an internet cable with the RJ-45 connector on one end only.
- b. Connect the internet cable to the camera data cable.
- c. Slide in the components through the end of the Internet cable without RJ-45 connector as shown below.



Figure 1-11

- d. Move the components toward the RJ-45 connector, secure item 1 to the Rubber Seal Ring of the camera data cable and secure item 2 to item 1 tightly.



Figure 1-12

IMPORTANT: Item 1 must be secured tightly to waterproof the cable.

- 6. For GV-Fisheye Camera that does not come with an IR LED ring, place the camera cover (for hard ceiling mount) on top of the camera and tighten the screws with the supplied torx wrench.



Figure 1-13

- 7. For GV-Fisheye Camera with an IR LED ring, follow the steps below to secure the IR LED ring to the camera.

- A. Secure the safety lock to the camera. Then secure the camera cover.



Figure 1-14

- B. Place the IR LED ring on top of the camera and tighten the screws with the torx wrench provided.



Figure 1-15

Caution: An operating IR LED ring may reach high temperatures. Disconnect the power supply and allow the IR LED ring to cool down before handling the device.

GV-FER12203



1. Paste the installation sticker to the ceiling board.
2. At the 3 dots, drill a hole slightly smaller than the plastic screw anchors provided.

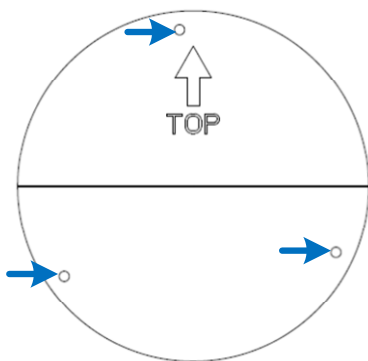

Figure 1-16

3. Insert the 3 plastic screw anchors in the drilled holes.
4. Secure the back plate onto the ceiling board with the 3 screws provided. If you want to thread the camera cables through the ceiling board, you can cut a cable opening as shown below.

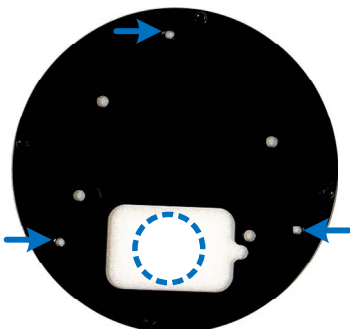

Figure 1-17

5. Open the camera cover by unscrewing the indicated screws.



Figure 1-18

6. Connect the Ethernet cable.

- a. Unplug the LAN / PoE connector and prepare an Ethernet cable with only one RJ-45 connector.



Figure 1-19

- b. Thread the Ethernet cable through the opening into the camera and through the plug and cap as shown below. Use the supplied ruler to make sure the length of the cable from the opening to the end of the cable is about 10 cm.

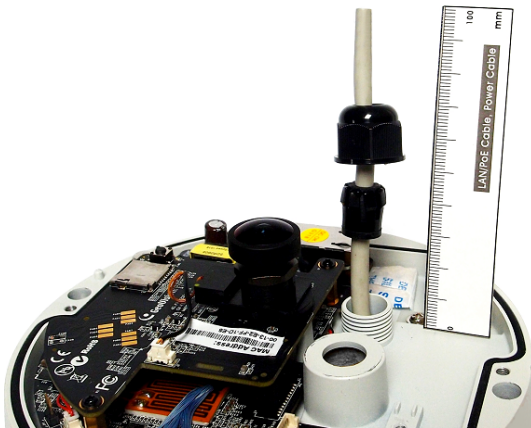

Figure 1-20

- c. Insert the plug into the opening and tighten the cap.

- d. Attach the supplied RJ-45 connector to the Ethernet cable, and plug the connector into the LAN / PoE port.
- e. Loosen the screw on the cable holder and thread the cable under the cable holder.



Figure 1-21

- 7. Connect the supplied data cable if needed.
 - a. Unscrew the hexagon washer on the data cable opening.



Figure 1-22

- b. Thread the data cable through the black rubber ring, and then through the opening into the camera.



Figure 1-23

- c. Slide the hexagon washer through the cable, and then tighten the washer.

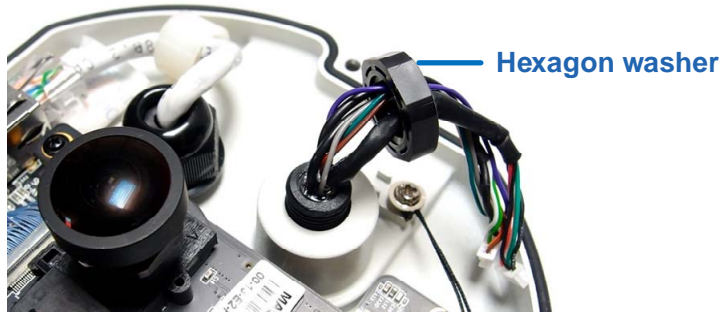

Figure 1-24

- d. Plug the pins of the cable to the camera as shown below.

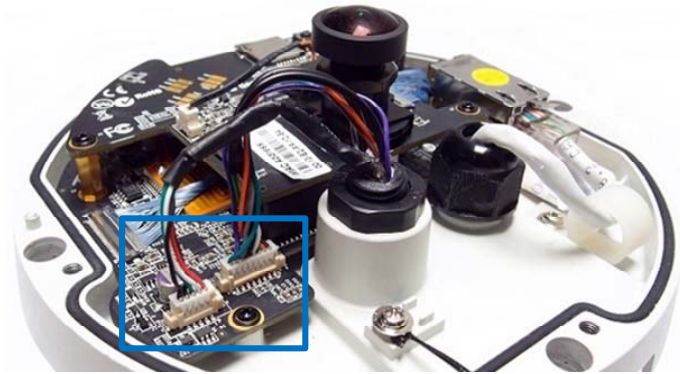

Figure 1-25

- 8. Secure the camera to the back plate by tightening the 4 screws as shown below. The cables can be threaded through the cable opening on the side or through the ceiling board.

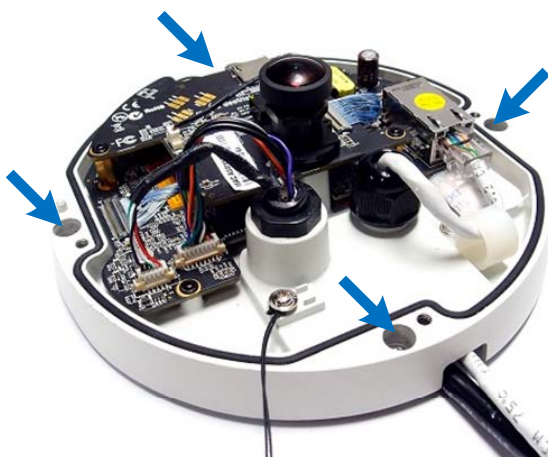

Figure 1-26

- 9. Secure the camera cover and tighten the 4 screws.

1.6.2 In-Ceiling Mount

In this section, we introduce two types of in-ceiling mounts: General In-Ceiling Mount and GV-UNFE2503.

General In-Ceiling Mount

In-Ceiling Mount allows the camera to be mounted into the ceiling, revealing a small portion of the camera. In-Ceiling Mount requires the ceiling board to be between 0.5 – 3.0 cm (0.2 – 1.18 in) thick.



Figure 1-27

Note: This in-ceiling mount is not applicable to the models with IR LED ring (GV-FE3403 / 5303 and GV-FER3403 / 5303), GV-FER12203 and GV-UNFE2503.

1. Place the installation sticker on the ceiling board, and cut the circle part out of the ceiling. To install GV-FE3402 / 5302 and GV-FER3402 / 5302, drill the 3 holes indicated as “Device”.

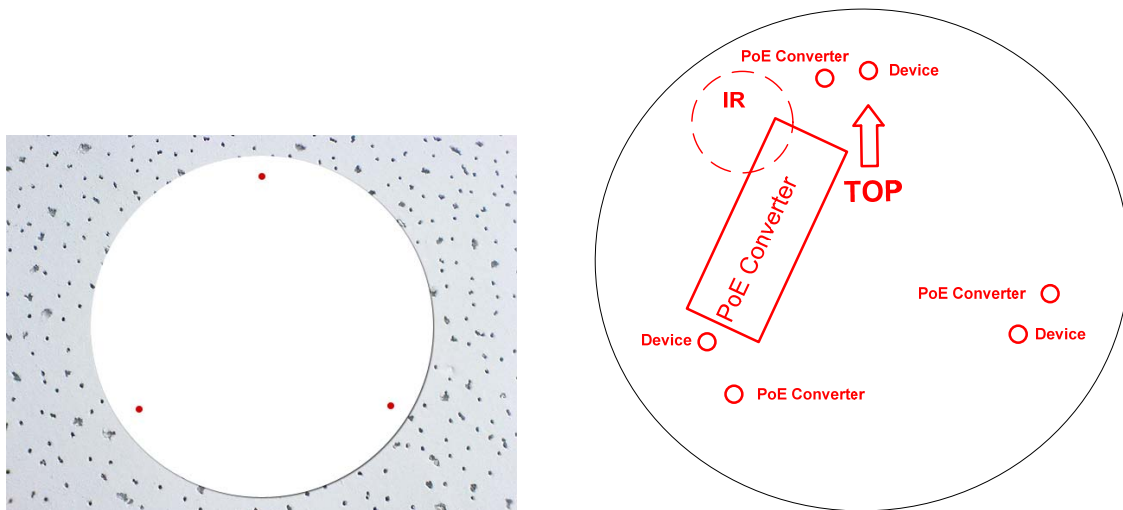

Figure 1-28

- Align the 3 support brackets with the holes on the back of the camera as shown below and secure using the in-ceiling mount screws provided.



Figure 1-29

- For outdoor GV-Fisheye Cameras (GV-FER3402 / 5302), install the supplied cable connector to waterproof the cable. Refer to step 5 in 1.6.1 *Hard Ceiling Mount* for details.
- Place the fisheye camera into the ceiling opening as shown below.



Figure 1-30

5. On the back side, make sure the black plastic clips are slightly above the ceiling board and pointing outward.



Figure 1-31

6. From the front side of the camera, tighten the screws.



Figure 1-32

7. Connect the camera with power, network and other wires. For details, see [1.7 Connecting the GV-Fisheye Camera](#).
8. Place the camera cover for in-ceiling mount on top of the camera and tighten the 3 screws or just put on the in-ceiling cover if it does not contain screws.



Figure 1-33

GV-UNFE2503

The IR Fisheye Camera is designed for outdoors. You can install the camera lens behind a ceiling or a wall.



Figure 1-34

Note: It is recommended to have the camera lens installed behind a ceiling board with the thickness between 3 mm to 30 mm.

1. Paste the installation sticker on the ceiling or the wall where you want to install the camera lens.
2. Drill 2 holes as indicated.

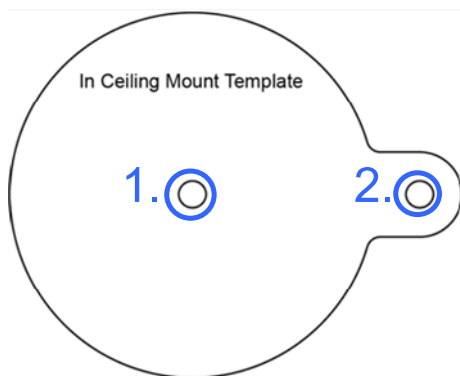

Figure 1-35

Note: Hole no. 2 is the top of the camera view.

- Using the 2 holes as the starting position, drill or cut out the shape of the template sticker with the tool of your choice.

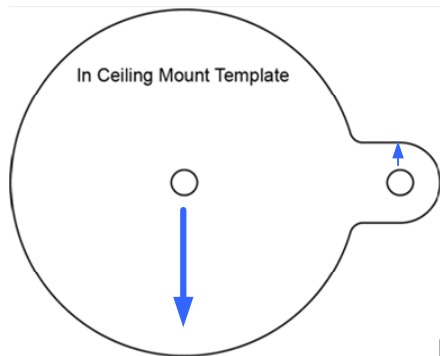

Figure 1-36

- Remove the IR LED power cable from the camera lens by rotating the silver ring.



Figure 1-37

- Remove the camera ring from the camera lens by rotating the ring.



Figure 1-38

Note: You must remove the IR LED power cable and the camera ring in order to secure the camera lens to the desired surface.

6. Insert the camera lens into the wall or ceiling.

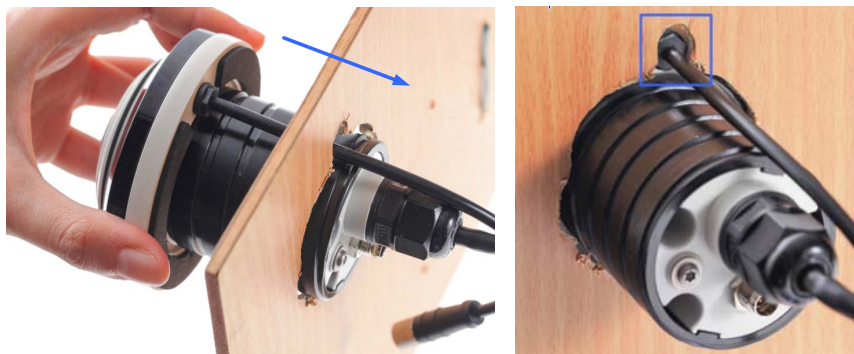

Figure 1-39

7. Assemble the camera ring to the camera lens by rotating the ring. Adjust the position of the lens before fully securing the ring.



Figure 1-40 Fasten the Camera Ring



Figure 1-41 Adjust the lens

Note: The side of the camera ring with the protruding notches must face the wall or ceiling.



Figure 1-42

8. Connect the IR LED cable to the camera lens. Rotate the silver ring to fasten the cable.
9. Place the main body mount where you want to install it, and secure the mount using one of the methods below.

- Insert and tighten the two supplied M3 screws.

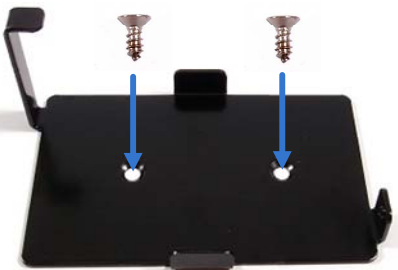

Figure 1-43

- Paste the main body adhesive tape on the bottom side of the main body mount.



Figure 1-44

10. Align the main body with the mount as shown below and secure with the supplied M2 screw.



Figure 1-45

11. Connect the camera lens and the main body with the RJ12 cable.

12. Connect the main body to the network and supply power via the PoE cable.

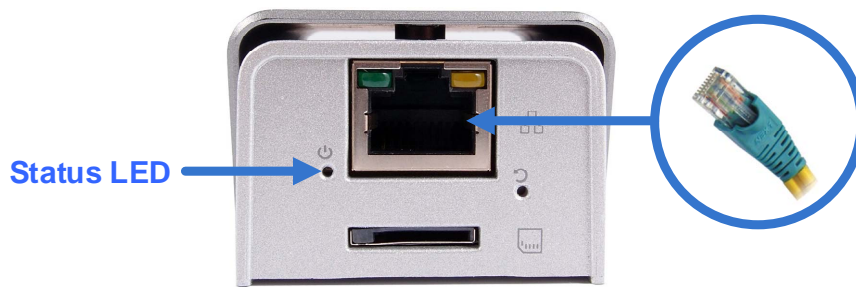

Figure 1-46

13. Access the live view. See 2.1 *Accessing the Live View, GV-IPCam H.264 Firmware Manual*.

1.6.3 Standard Wall Mount and Ground Mount

To mount the camera on a wall, follow the instructions in *1.6.1 Hard Ceiling Mount*.



Figure 1-47

Hint:

3. Mount the fisheye camera in the middle of the wall to have an excellent overview. Or ensure the camera is focused on the most important areas of the room as directly as possible to have the desired detailed recognition.
 4. Orientate your the camera using the printed text “TOP” on the camera or the installation sticker.
-

1.6.4 Ground Mount

For ground mount, simply install the hard ceiling cover and place the camera on a flat surface such as a conference table.



Figure 1-48

1.7 Connecting the GV-Fisheye Camera

1.7.1 GV-FE2301 / 4301

GV-FE series come with a 5-pin data cable that allows you to connect to the power and any I/O devices.

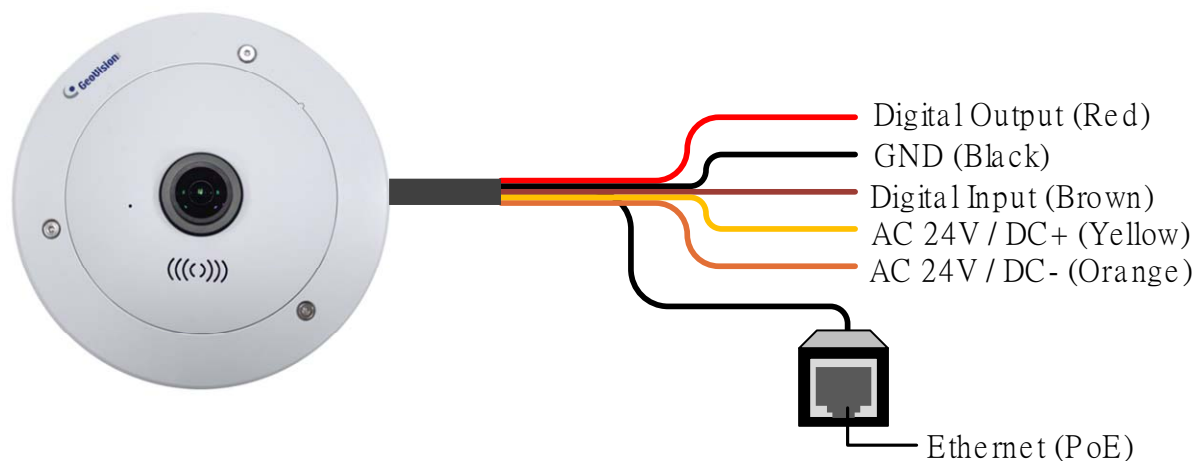

Figure 1-49

Wire Definition

No.	Wire Color	Definition
1	Yellow	AC 24V+ / DC 12V+
2	Orange	AC 24V- / DC 12V-
3	Brown	Digital Input
4	Red	Digital Output
5	Black	GND

Connecting to Power

You can connect to power using either the power adapter provided or a Power over Ethernet (PoE) adapter. See “Power over Ethernet” in Specifications later in this manual before purchasing a PoE adapter. To connect to power using the power adapter, follow the steps below to connect the orange and yellow wires of the camera to the 3-pin or 2-pin terminal block provided.

1. Insert the yellow wire to the pin on the right-side of the terminal block and the orange wire to the pin on the left-side of the terminal block.
2. Use a small flat-tip screwdriver to secure the screws above the pins.

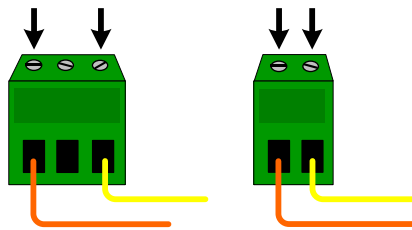

Figure 1-50

3. Connect the DC 12V Power Adapter to the Terminal Block.

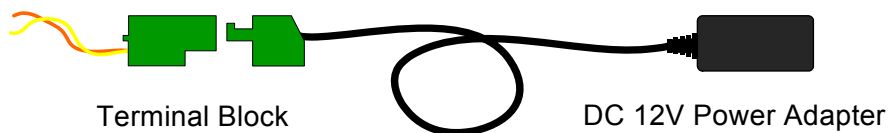

Figure 1-51

Note:

1. A DC 12V power adapter has been provided, but both AC 24V power adapter and DC 12V power adapter are compatible.
 2. The power status LED will not be visible unless the camera cover is removed.
-

1.7.2 GV-FE3402 / 3403 / 5302 / 5303

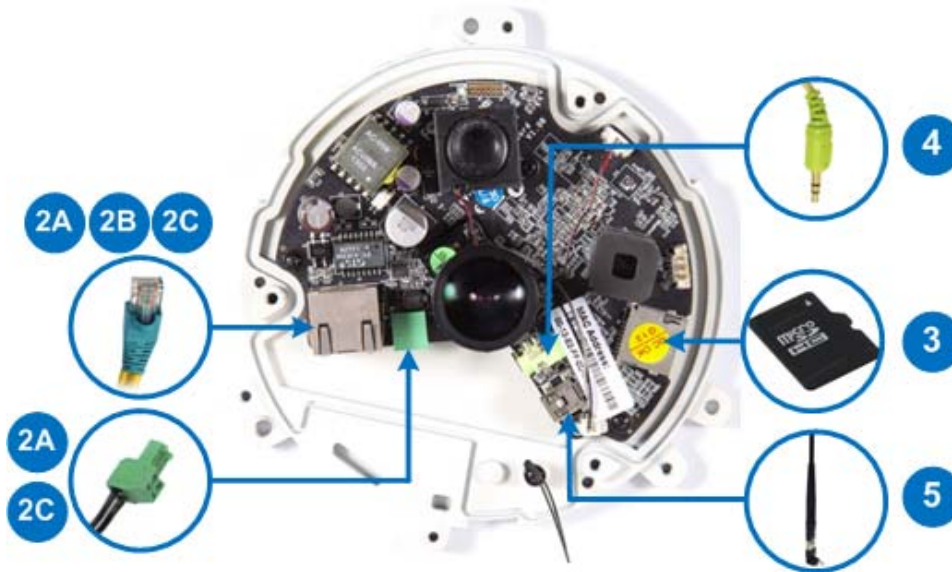

Figure 1-52

1. Remove the camera cover with the supplied torx wrench.
2. Supply power and network to the camera with one of the following methods:
 - A. **Power adapter:** plug in the power adapter and connect a standard network work cable.
 - B. **Power over Ethernet (PoE):** connect the camera to a PoE switch with a standard network cable to supply power and network.
 - C. **PoE Converter:** this method is only applicable to indoor GV-Fisheye Camera installed with an IR LED ring (GV-FE3403 / 5303). A PoE converter allows the camera to be connected to a PoE switch (thus supplied with network and power over a network cable), and also supplies power to IR LED ring. For installation steps, see *1.7.4 Connecting PoE Converter and IR LED Ring for GV-FE3403 / 5303*.
3. Optionally insert a micro SD card (SD/SDHC, version 2.0 only, Class 10).
4. Optionally connect an external speaker.
5. Optionally connect a GV-WiFi Adapter (for WiFi accessibility) or an external USB hard drive (for additional storage).
6. Secure the camera cover with the supplied torx wrench.

Note: For details on the limitations and requirements of mini USB port, refer to *Note for USB Storage and WiFi Adapter* at the beginning of this manual.

1.7.3 Connecting PoE Converter and IR LED Ring for GV-FE3403 / 5303

To install a PoE converter, follow the steps below.

Note: Instead of installing the PoE converter, you can connect the camera to a PoE switch and the IR LED ring with a power adapter (optional accessory).

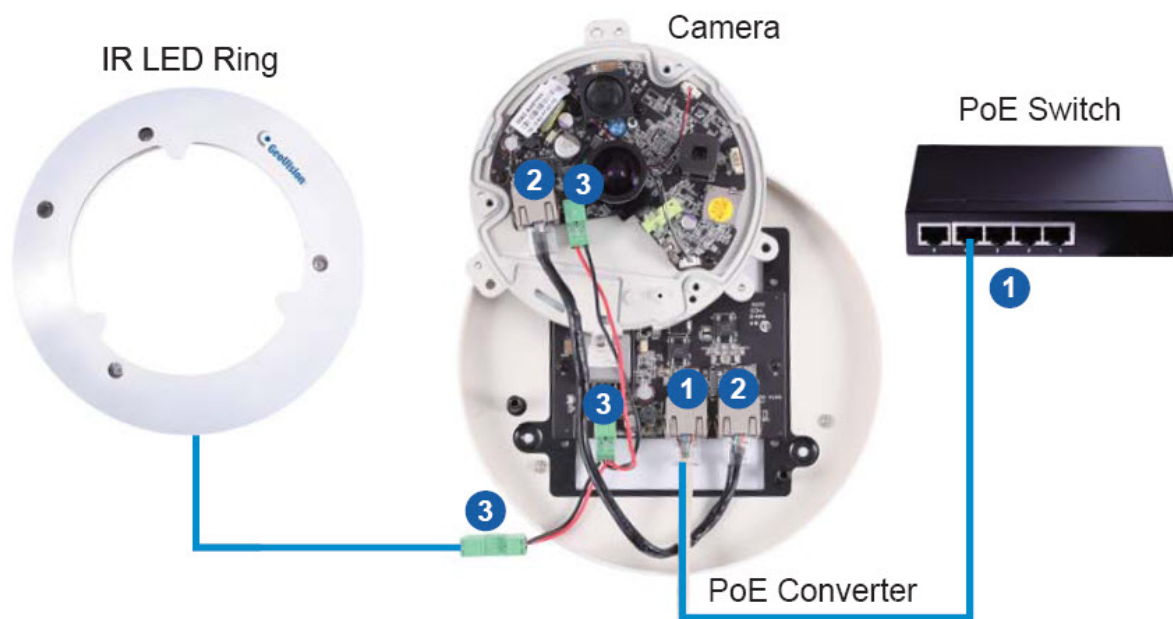

Figure 1-53

1. Connect the PoE converter to a PoE switch with a standard network cable. Use the RJ-45 connector on the left.

Note:

1. Due to limited space inside the PoE converter, use a standard network cable without the rubber boot.
 2. The camera will not work if you connect the wrong devices to the two RJ-45 connectors on the PoE converter.
-

2. Connect PoE Converter and the camera with the supplied network cable. Use the RJ-45 connector on the right.

3. Plug one of the PoE converter's terminal blocks to the camera and the other one to the IR LED ring.

IMPORTANT: It is advised to shorten the IR LED ring's wire to approximately 20 cm for it to fit inside the PoE converter.

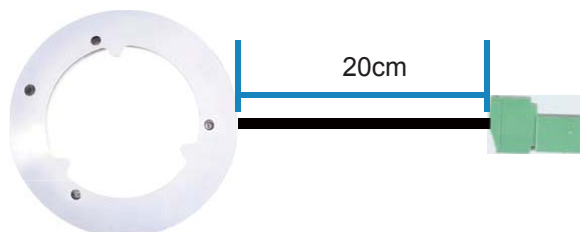

Figure 1-54

4. Secure the camera to the PoE converter with the supplied screws.

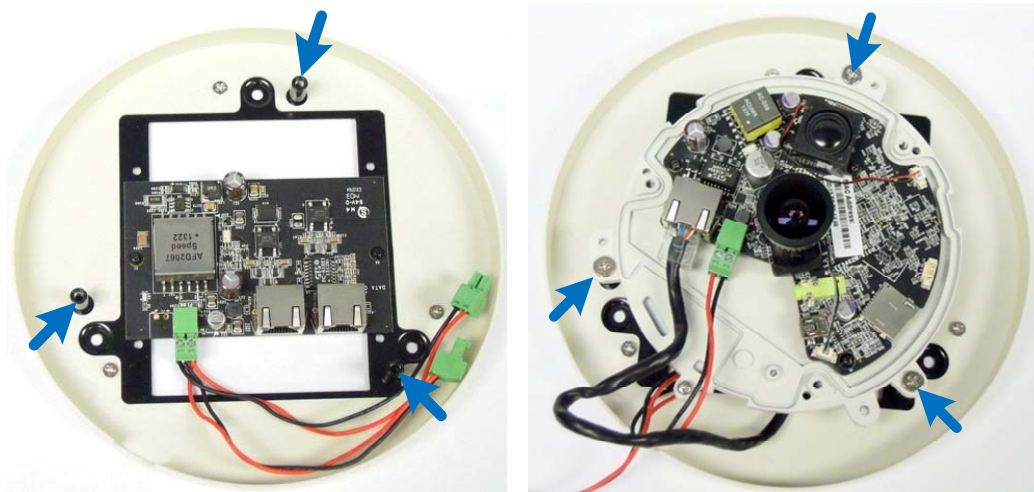

Figure 1-55

5. Secure the PoE converter to the ceiling with 3 self-prepared screws.

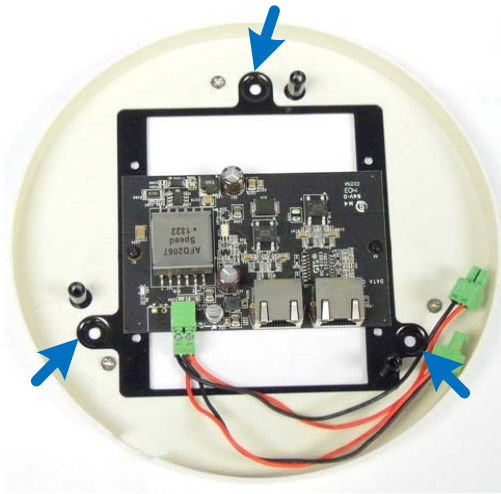

Figure 1-56

1.7.4 GV-FER3402 / 3403 / 5302 / 5303

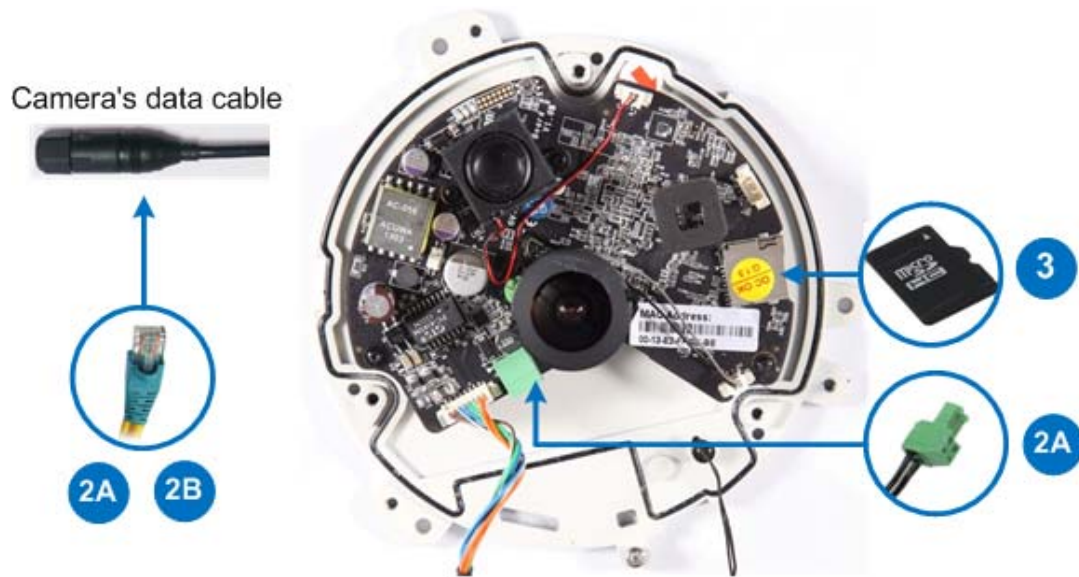

Figure 1-57

1. Remove the camera cover with the supplied torx wrench.
2. Supply power to the camera with one of the following:
 - A. **Power adapter:** see *Assembling the Power Adapter* later in this section.
 - B. **Power over Ethernet (PoE):** connect the camera to a PoE switch with a standard network cable to supply power and network.
3. Optionally insert a micro SD card (SD/SDHC, version 2.0 only, Class 10).
4. Secure the camera cover with the supplied torx wrench.

Assembling the Power Adapter

1. Insert the supplied power cable into the supplied waterproof rubber and plug it into the camera.

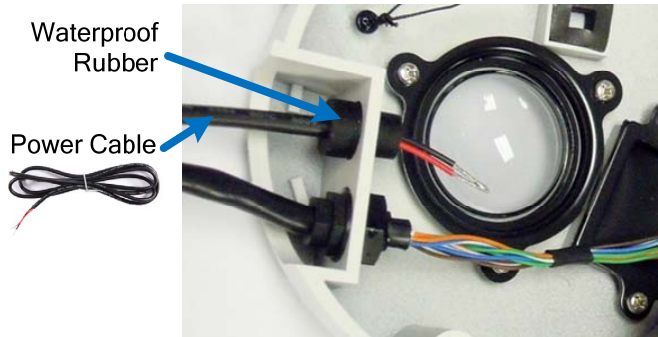

Figure 1-58

2. Insert the power cable into the supplied female terminal block as illustrated and plug it into the terminal block connector in the camera.

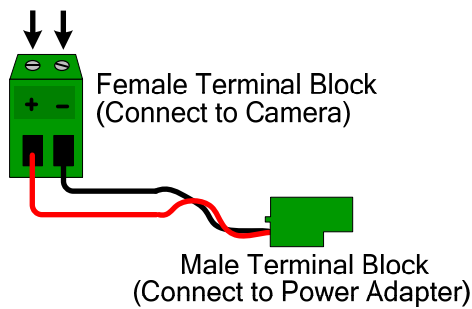

Figure 1-59

3. Insert the power wires at the other end into the male terminal block as illustrated and plug it to the power adapter.

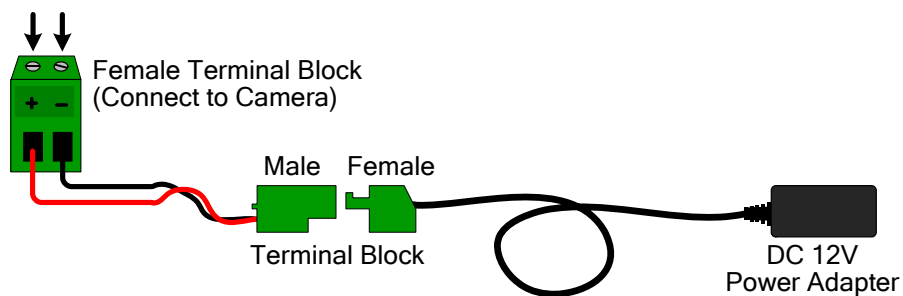

Figure 1-60

1.7.5 GV-FER12203

The GV-FER12203 comes with a data cable that allows you to connect to the power adapter, WiFi adapter, microphone, speaker, and any I/O devices.

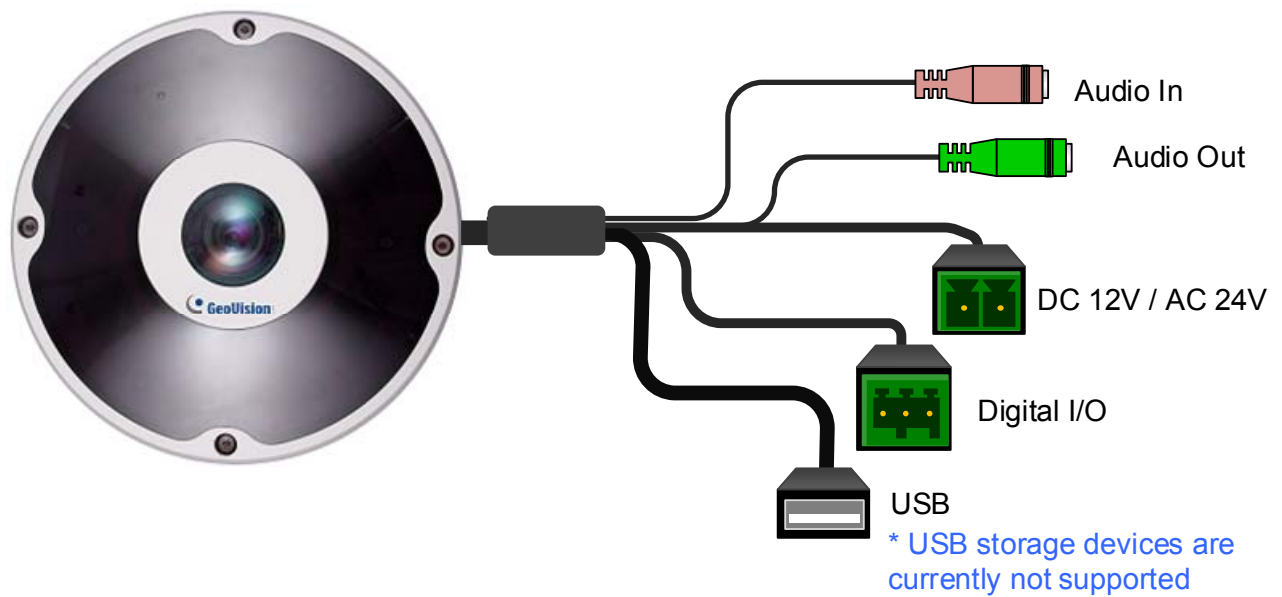

Figure 1-61

Connecting to Power

There are two ways to supply power to the camera:

- Use a Power over Ethernet (PoE) adapter to connect the camera to the network, and the power will be provided at the same time. See “Power over Ethernet” in Specifications later in this manual before purchasing a PoE adapter.
- Plug the power adapter to the terminal block on the data cable.

Chapter 2 Getting Started

This section provides basic information to get the camera working on the network.

2.1 Installing on a Network

These instructions describe the basic connections to install the camera on the network.

1. Using a standard network cable, connect the camera to your network.
2. Connect power using one of the methods:
 - Using the supplied power adapter, connect to power. For details, see *1.7 Connecting the Data Cable*.
 - Use the Power over Ethernet (PoE) function. The power will be provided over the network cable.
3. You can now access the Web interface of the camera.
 - If the camera is installed in a LAN without the DHCP server, the default IP address **192.168.0.10** will be applied. You also can assign a static IP address. See *2.1.2 Assigning an IP Address*.
 - If the camera is installed in a LAN with the DHCP server, use GV-IP Device Utility to look up the camera's dynamic IP address. See *2.1.1 Checking the Dynamic IP Address*.

Note: See "Power over Ethernet" in Specifications later in this manual before purchasing a PoE adapter.

2.1.1 Checking the Dynamic IP Address

Follow the steps below to look up the IP address and access the Web interface.

1. Install the GV-IP Device Utility program included on the Software DVD.

Note: The PC installed with GV-IP Device Utility must be under the same LAN with the camera you wish to configure.

2. On the GV-IP Utility window, click the  button to search for the IP devices connected in the same LAN. Click the **Name** or **Mac Address** column to sort.

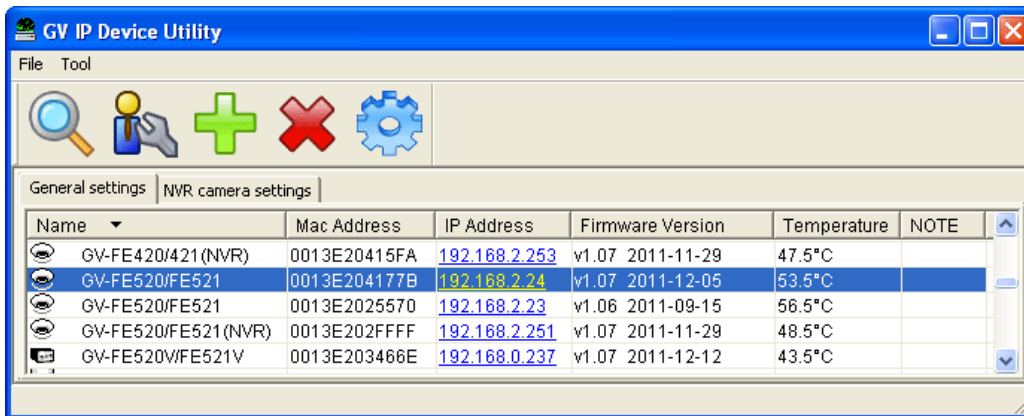

Figure 2-1

3. Find the camera with its Mac Address, click on its IP address and select **Web Page**.

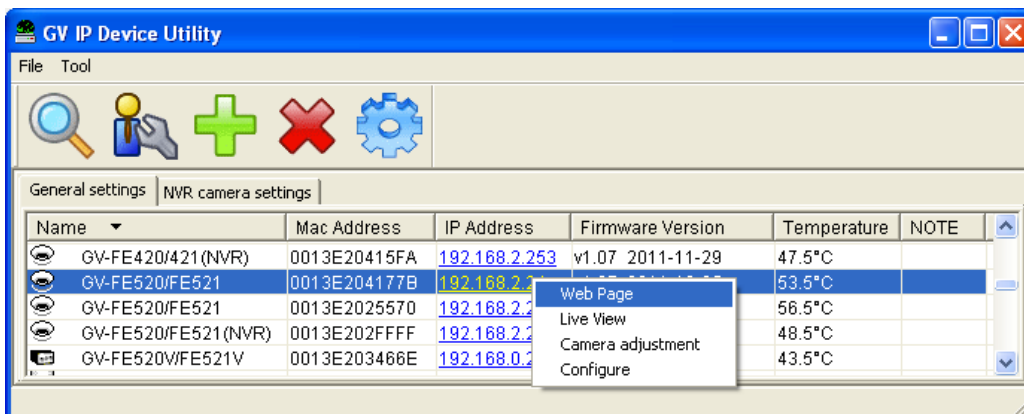

Figure 2-2

4. The login page appears.

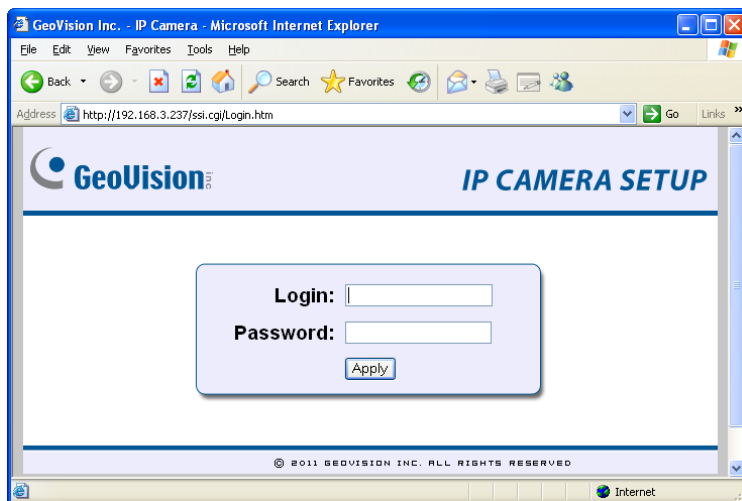

Figure 2-3

5. Type the default ID and password **admin** and click **Apply** to login.

2.1.2 Assigning an IP Address

By default, GV-Fisheye Camera that are connected to LAN without a DHCP server, are assigned with the static IP address **192.168.0.10**. Follow the steps below to assign a new IP address to avoid IP conflict with other GeoVision devices.

Note:

1. The computer used to set the IP address must be under the same network with the camera.
 2. If your router supports the DHCP server, the camera will obtain a dynamic IP address from the DHCP server each time it connects to the LAN, instead of using 192.168.0.10. The default setting for automatic IP assignment is not available for GV-FE2301 / 4301 using firmware V1.06 or earlier.
-

1. Open your web browser, and type the default IP address <http://192.168.0.10>
2. In both Login and Password fields, type the default value **admin**. Click **Apply**.
3. In the left menu, select **Network** and then **LAN** to begin the network settings.

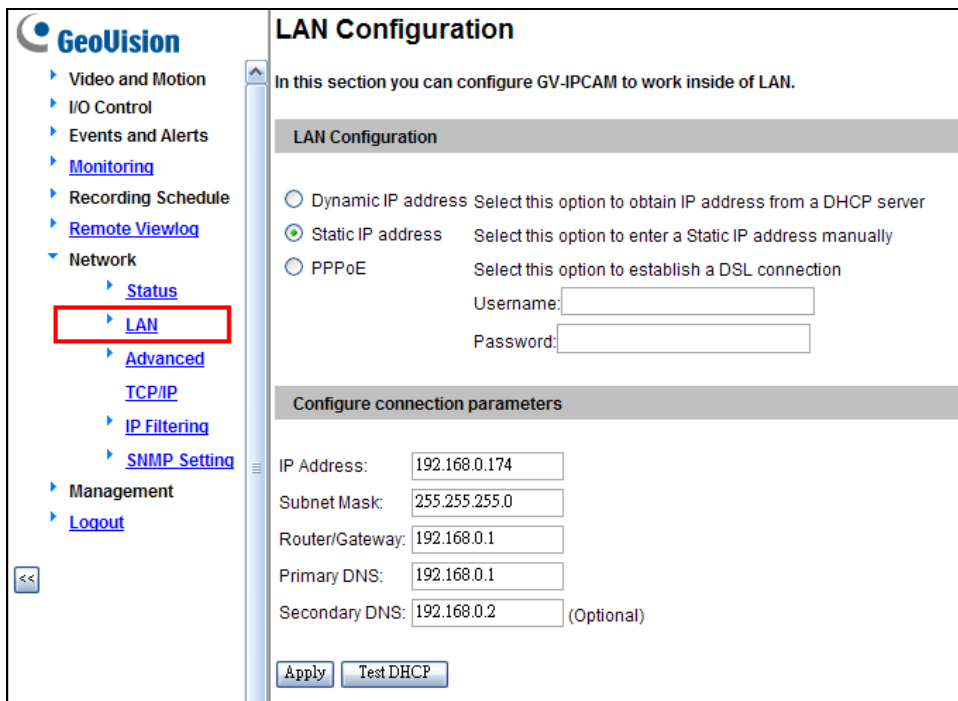

Figure 2-4

4. Select **Static IP address**. Type IP Address, Subnet Mask, Router/Gateway, Primary DNS and Secondary DNS in the **Configure connection parameters** section.
5. Click **Apply**. The camera is now accessible by entering the assigned IP address on the Web browser.

IMPORTANT:

1. If **Dynamic IP Address** or **PPPoE** is enabled, you need to know which IP address the camera will get from the DHCP server or ISP to log in. If your camera is installed in a LAN, use the GV-IP Device Utility to look up its current dynamic address. See *2.1.1 Checking the Dynamic IP Address*.
If your camera uses a public dynamic IP address, via PPPoE, use the Dynamic DNS service to obtain a domain name linked to the camera's changing IP address first. For details on Dynamic DNS Server settings, see *4.7.2 Advanced TCP/IP*.
2. If **Dynamic IP Address** and **PPPoE** is enabled and you cannot access the unit, you may have to reset it to the factory default settings and then perform the network settings again.

To restore the factory settings, see *6.3 Restoring to Factory Default Settings*.

2.1.3 Configuring the Wireless Connection

Wireless settings are only applicable to GV-FE3402 / 3403 / 5302 / 5303 and GV-FER12203. Insert a WiFi adapter to the camera and follow the steps below to set up a wireless connection to your camera.

1. To set up the wireless LAN for the first time, power on and connect a standard network cable to the camera.
2. An IP address will be automatically assigned to the camera. Use GV-IP Device Utility to search for the device. For details, see *2.1.1 Checking the Dynamic IP Address*.
3. Configure the wireless settings.
 - A. On the Web interface, select **Network**, select **Wireless** and **Client Mode**. This dialog box appears.

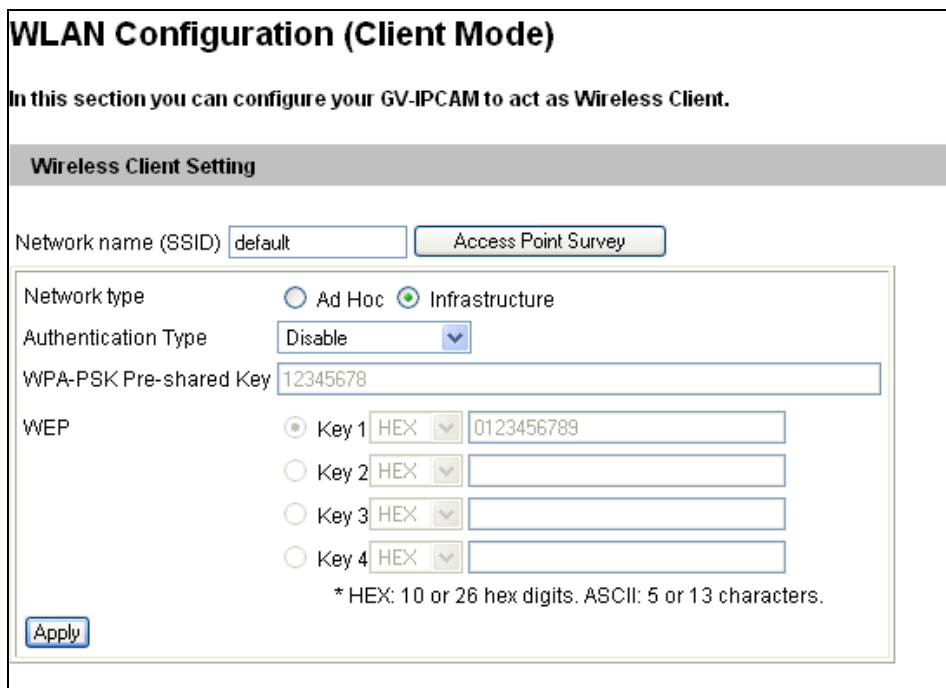

Figure 2-5

- B. Type the Network Name (SSID) or click the **Access Point Survey** button to search and select for the available Access Points/wireless stations.
- C. Select **Ad-Hoc** or **Infrastructure** for the Network type.
- D. Select the **Authentication Type** using the drop-down list. You can also obtain this information by clicking the **Access Point Survey** button.
- E. Type the **WPA-PSK Pre-shared Key** or **WEP** depending on the encryption setting for the Access Point.

F. Click **Apply** to save the configuration.

Note:

1. Your encryption settings must match those used by the Access Points or wireless stations with which you want to associate.
2. When **Ad Hoc** is used, only **WEP** encryption is supported.
3. When you lose the wireless access, you can still access the unit by connecting it to a LAN and using the GV-IP Device Utility to search for the device.
4. For detailed information on configuring the wireless LAN, see *20.7.2 Wireless Client Mode*.

4. Enable wireless LAN.

A. On the Web interface, select **Network** and **LAN**. This page appears.

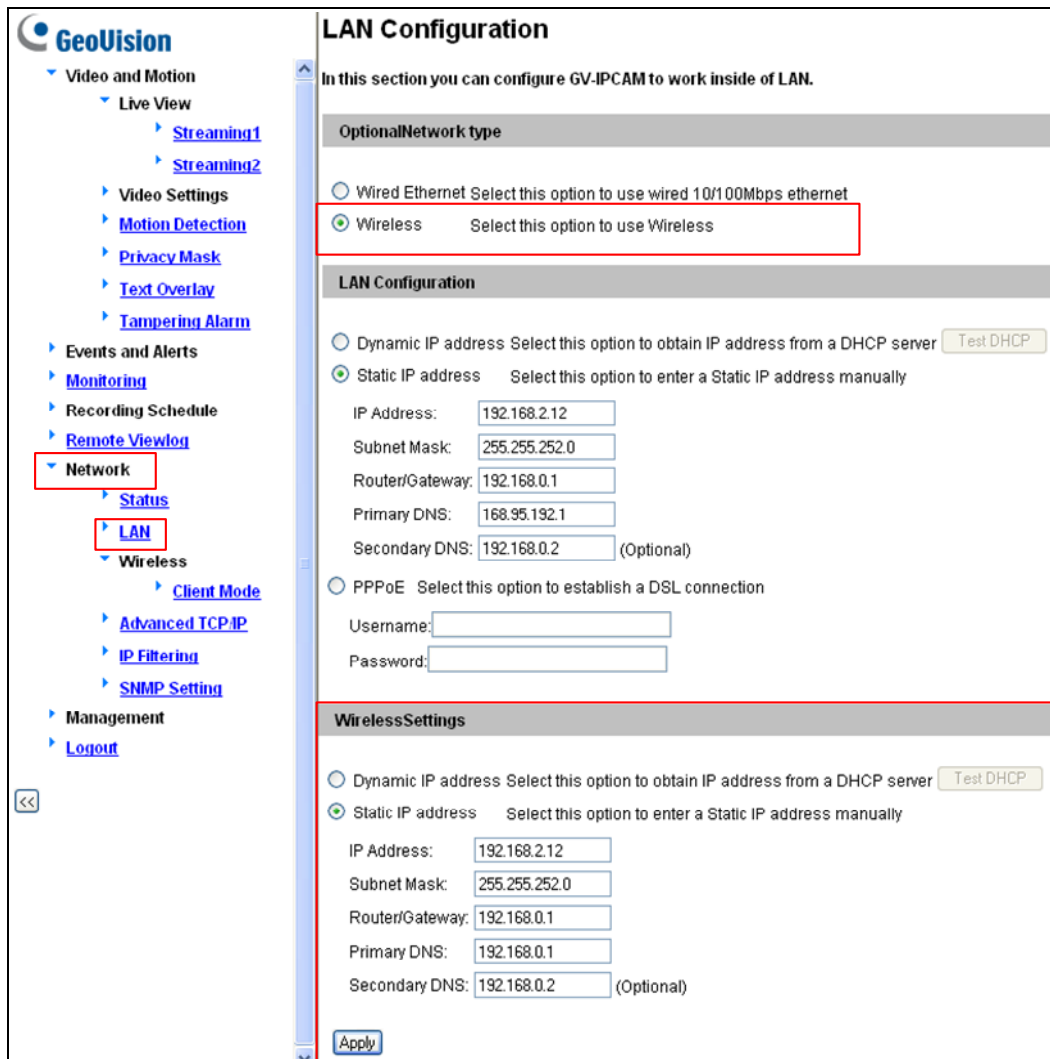

Figure 2-6

- B. Select **Wireless** for Optional Network Type.
 - C. To use a dynamic IP address assigned by the DHCP server, select **Dynamic IP address**. To use a fixed IP address, select **Static IP address** and type the IP address information.
5. Click **Apply**. The Camera will start creating a wireless connection to the access point.
 6. Unplug the Ethernet cable.

2.2 Configuring the Basics

Once the camera is properly installed, the following important features can be configured using the browser-based configuration page and are discussed in the following sections in this manual:

- **Date and time adjustment:** see *4.8.1 Date and Time Settings*.
- **Login and privileged passwords:** see *4.8.3 User Account*.
- **Network gateway:** see *4.7 Network*.
- **Camera image adjustment:** see *3.2.3 The Control Panel of the Live View Window*.
- **Video format, resolution and frame rate:** see *4.1.1 Video Settings*.

Chapter 3 Accessing the Camera

Two types of users are allowed to log in to the camera: **Administrator** and **Guest**. The Administrator has unrestricted access to all system configurations, while the Guest has the access to live view and network status only.

3.1 Accessing Your Surveillance Images

Once installed, your camera is accessible on a network. Follow these steps to access your surveillance images:

1. Start the Internet Explorer browser.
2. Type the IP address or domain name of the camera in the **Location/Address** field of your browser.



Figure 3-1

3. Enter the login name and password.
 - The default login name and password for Administrator are **admin**.
 - The default login name and password for Guest are **guest**.
4. A video image, similar to the example in Figure 3-2, is now displayed in your browser.

Note: To enable the updating of images in Microsoft Internet Explorer, you must set your browser to allow ActiveX Controls and perform a one-time installation of GeoVision's ActiveX component onto your computer.

3.2 Functions Featured on the Main Page

This section introduces the features of the **Live View** window and **Network Status** on the main page. The two features are accessible by both Administrator and Guest.

Main Page of Guest Mode

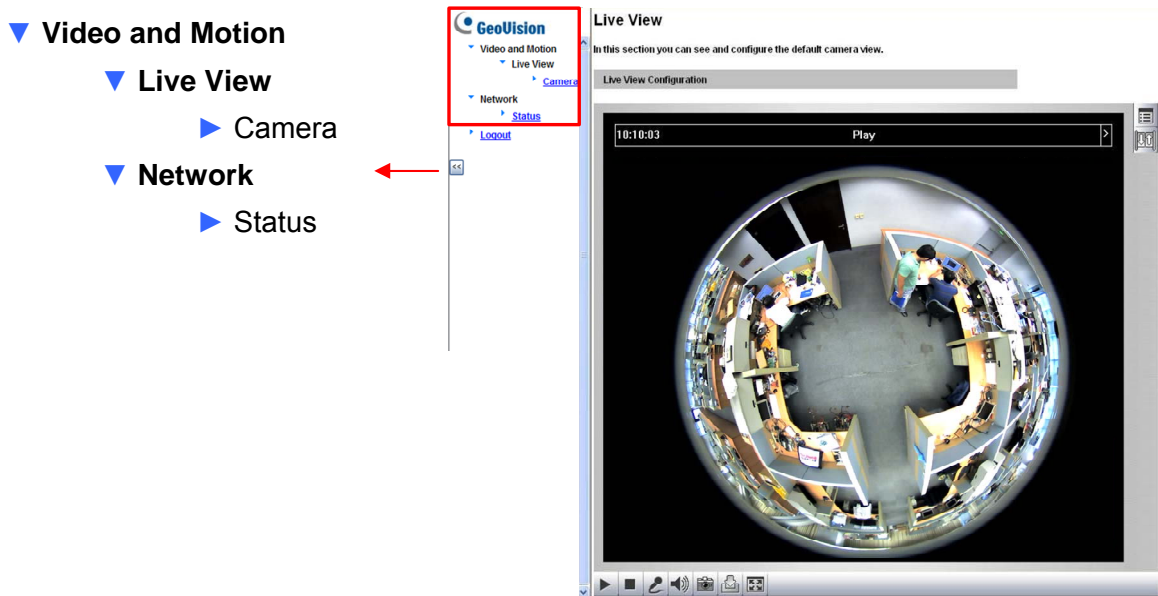

Figure 3-2

The camera can process one video stream in two different codec and image settings. In the Administrator mode, both streams are available. Click Streaming 1 or Streaming 2 in the left menu to access the live view. In the Guest mode, only one stream is available, as shown in Figure 3-2.

3.2.1 The Live View Window

Internet Explorer

When accessing the camera live view using Internet Explorer, the following window appears.



Figure 3-3

No.	Name	Function
1	Play	Plays live video.
2	Stop	Stops playing video.
3	Microphone	Talks to the surveillance area from the local computer. Click the Push to talk button (from the pop-up menu) for the camera to switch between audio transmission and reception, where only one party can speak at a time.
4	Speaker	Listens to the audio around the camera.
5	Snapshot	Takes a snapshot of live video. --- See 3.2.4 <i>Snapshot of a Live Video</i> .
6	File Save	Records live video to the local computer. --- See 3.2.5 <i>Video Recording</i> .
7	Full Screen	Switches to full screen view. Right-click the image to have these options: Snapshot, Resolution, Wide Angle Lens Dewarping, PIP, PAP, Geo Fisheye, Zoom In and Zoom Out . --- See 3.2.6 <i>Wide Angle Lens Dewarping</i> --- See 3.2.7 <i>Picture-in-Picture and Picture-and-Picture View</i> --- See 3.2.2 <i>Fisheye View</i>
8	I/O Control	Enables the I/O Control Panel or the Visual Automation. This function is only supported by GV-FE2301 / 4301 and GV-FER12203. --- See 3.2.14 <i>I/O Control</i> .
9	Show System Menu	Brings up these functions: Alarm Notify, Video and Audio Configuration, Remote Config, Show Camera Name and Image Enhance . --- See 3.2.9 <i>Alarm Notification</i> --- See 3.2.10 <i>Video and Audio Configuration</i> --- See 3.2.11 <i>Remote Configuration</i> --- See 3.2.12 <i>Camera Name Display</i> --- See 3.2.13 <i>Image Enhancement</i> respectively.
10	Control Panel	Displays the camera information, video settings, audio data rate, I/O device status and the images captured upon alarm. Also allows you to adjust image quality and install the program from the hard drive.

Non-IE Browsers

When accessing the camera live view using Google Chrome, Firefox or Safari, the following window appears. The following functions are not supported using non-IE browsers: Control panel, function buttons, Motion Detection, Tampering Alarm, Visual Automation, Text Overlay, and Two-Way Audio.

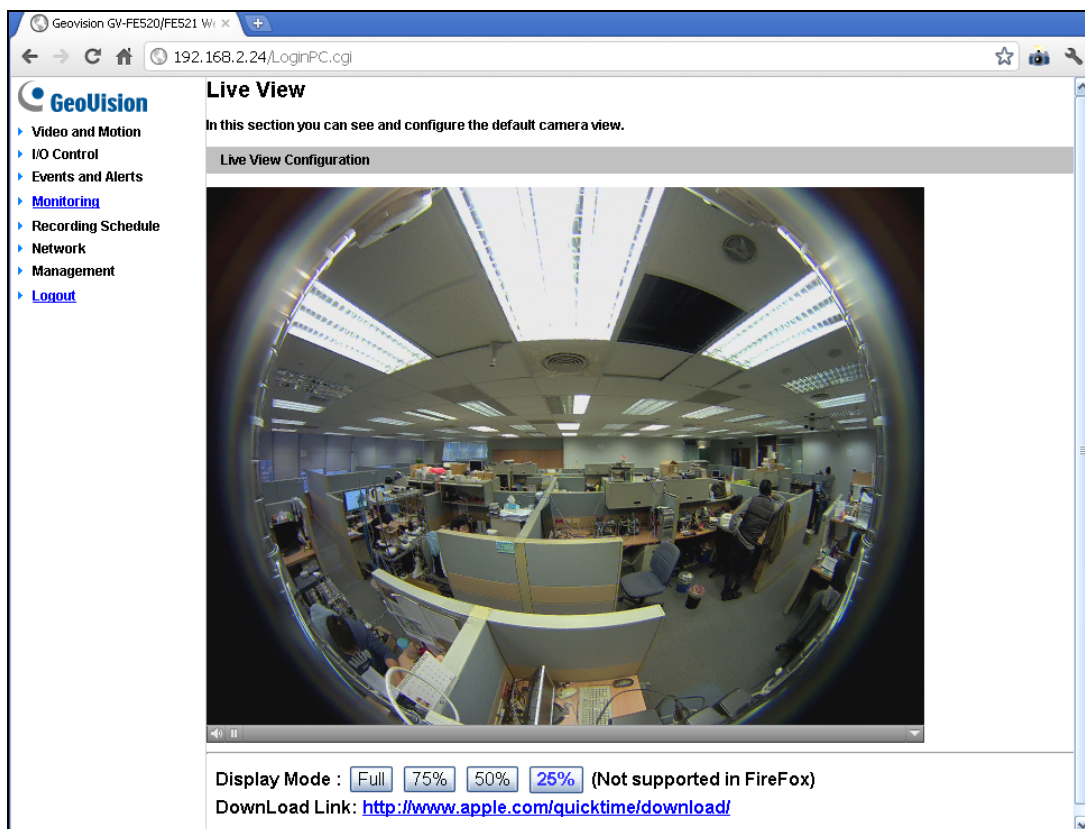

Figure 3-4

Note: Non-IE browsers do not support OCX plugin which obstructs the smoothness of the live view. For users of non-IE browsers, to enjoy smooth live view, download **GV-WebViewer** right after you log on and you can also have access to the full features of the camera.

3.2.2 Fisheye View

To enable the fisheye options, right-click the live view and select **Geo Fisheye**. Right-click the image again and select **Fisheye Option** to see the following options.

- **Image Alignment:** By default, the image should be properly aligned already. If not, follow the steps below to align the image for each model:
 - **GV-FE3402 / 3403 / 5302 / 5303 and GV-FER3402 / 3403 / 5302 / 5303 / 12203:** Align the red circle with the outer edge of the camera image, and then align it with the inner edge of the image frame to achieve optimal results.



Figure 3-5

- **GV-FE2301 / 4301:** Align the red circle with the edge of the camera image. You can eliminate the darker areas toward the edge of the image by making the red circle smaller, but the field of view will be slightly reduced.

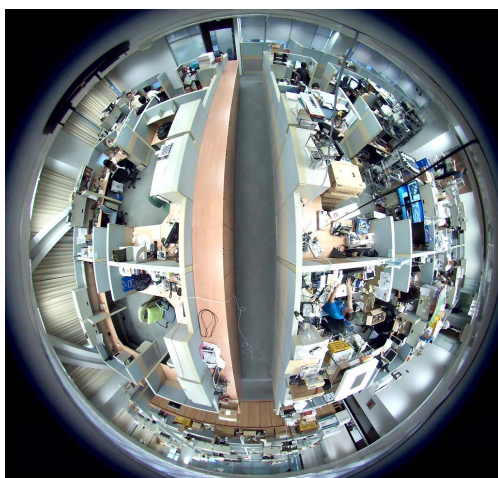
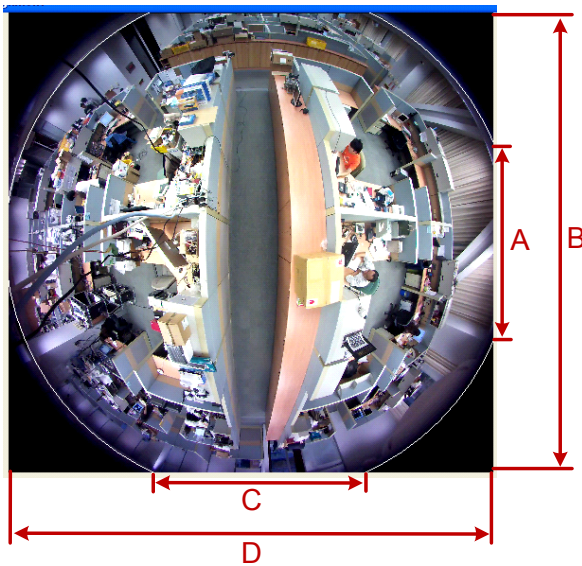

Figure 3-6 When GV-FE2301 / 4301 images are aligned, all four edges will be cropped slightly.

Note:

The circular source image of GV-FE2301 / 4301 should be centered and slightly cropped on all four edges. If the image is not centered, please contact your sales representative and send your device back to GeoVision for adjustment.

To determine whether your device needs adjustment, measure the length of a longer cropped edge and the length of that entire edge. Divide the length of the cropped edge by the length of the entire edge. The ratio for left and right edges should be less than or equal to 5/9 and the ratio for the top and bottom edges should be less than or equal to 5/8.



Left and right:

$$\frac{A}{B} \leq \frac{5}{9}$$

Top and bottom:

$$\frac{C}{D} \leq \frac{5}{8}$$

■ **Camera Modes:** You can choose among four view modes.

- **Quad view:** Composed of four PTZ views.
- **360 degree:** Composed of two PTZ view and one 360° panoramic view.
- **Dual 180 degree:** Composed of two 180° views.
- **Single view:** Composed of one PTZ view.



Quad view: 4 PTZ views

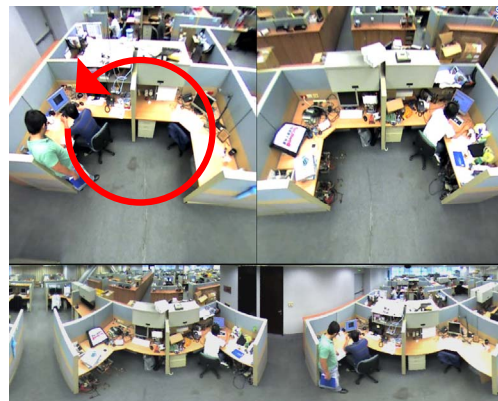

360 degree: 2 PTZ views & 1 360° view

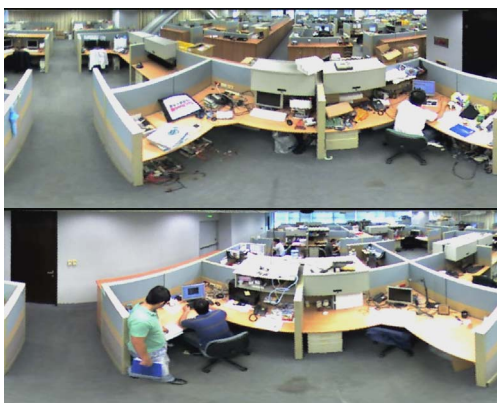

Dual 180 degree: 2 180° views

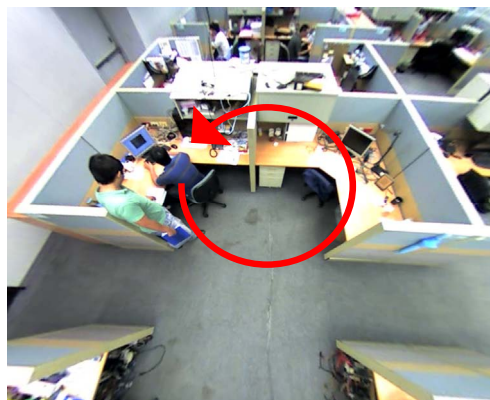

Single view: 1 PTZ view

Figure 3-7

Note: When wall mount is selected for **Camera Position**, only one 180° view will be displayed.

- **Camera Position:** Select **Ceiling**, **Wall** or **Ground** according to where the camera is mounted.
- **Adjust AutoPan Speed At Top-Left Channel:** Select low, medium, or high speed to enable Auto Pan for one PTZ view at the rotation speed of your choice. This option applies to **Quad view**, **360° degree** and **Single view**.
- **Zoom:** Select **Zoom In** or **Zoom Out** and then click on the image.
- **Show Source Video at Top-Right Channel:** Shows the circular source image in the top-right quadrant when **Quad view** is selected.
- **360 degrees Object Tracking:** Tracks moving objects under 360 degree view. Refer to 3.2.8 *Object Tracking* for more details.
- **Settings:** The following settings are available.
 - **Screen Ratio Setting:** Select a ratio that best fits the display ratio of your computer.
 - **Wide View:** Increase the height of the 180 degree view when camera position is set to wall mount.
 - **Hardware Acceleration:** Dewarps fisheye view processed by GPU to lower CPU loading.
 - **Frame Rate Control:** You can set the frame rate of the live view image.
 - **Show Original Video in Low Resolution:** Shows circular source image when the resolution is low. This option only works on the GV-System / GV-VMS when the fisheye camera is connected to a GV-System / GV-VMS.

Note: The default setting for **Hardware Acceleration** is enabled for GPU dewarping and it automatically detects the Screen Ratio Setting. If you clear **Hardware Acceleration**, it changes to CPU dewarping and you can select the Screen Ratio Setting.

You can drag and drop PTZ view or 180° view to adjust the viewing angle.

3.2.3 The Control Panel of the Live View Window

To open the control panel of the Live View window, click the arrow button on top of the viewer. You can access the following functions by using the left and right arrow buttons on the control panel.

Click the arrow button to display the control panel.



Figure 3-8

Tip: The administrator can also use the GV-IP Device Utility and click the camera's IP address to access the live view and adjust camera image settings.

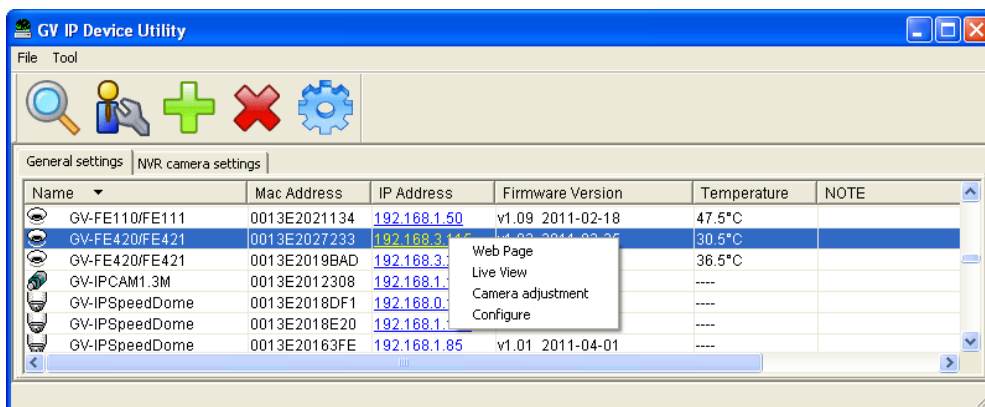

Figure 3-9

[Information] Displays the version of the camera, local time of the local computer, host time of the camera, and the number of users logging in to the camera.

[Video] Displays the current video codec, resolution and data.

[Audio] Displays the audio data rates when the microphone and speaker devices are enabled.

[I/O Control] Provides a real-time graphic display of the input and output status. You can force the output to be triggered by double-clicking its icon.

[Alarm Notify] Displays images captured upon sensor triggers and/or motion detection. For this function to work, you must configure the Alarm Notify settings first. See 3.2.9 *Alarm Notification*.

[Camera Adjustment] Allows you to adjust the image quality.



Figure 3-10

- **Brightness:** Adjusts the brightness of the image.
- **Contrast:** Adjusts the relative differences between one pixel and the next.
- **Saturation:** Adjusts the saturation of the image.
- **Sharpness:** Adjusts the sharpness of the image.
- **Gamma:** Adjusts the relative proportions of bright and dark areas.
- **White balance:** The camera automatically adjusts the color to be closest to the image you are viewing. You can choose one of the three presets: **Indoor**, **Fluorescent**, and **Outdoor**. You can also choose **Manual** to adjust the white balance manually.
- **Flicker less:** The camera automatically matches the frequency of your camera's imager to the frequency of indoor light sources, e.g. fluorescent lighting. You can also select 50 Hz or 60 Hz manually. If these don't match, faint light and dark bars may appear in your images. Check the power utility to determine which frequency is used.
- **Image Orientation:** Changes the image orientation on the Live View window.
- **Slowest Shutter Speed:** Shutter speed controls the amount of the light that enters the image sensor and directly impacts the quality of image presentation. Under low light conditions, a faster shutter speed will lower color quality and image clarity. A slow shutter speed allows more light to enter and creates a brighter overall image, but moving objects may appear blurry. You can manually select a shutter speed, select **Auto** for automatic shutter speed, or select **Auto (Higher Shutter Speed)** for faster automatic shutter control.
- **D/N:** Sets the Day/Night mode of the camera. Select **Auto** for automatic switch between day mode and night mode depending on the amount of light detected. Select **Black and white** to switch the camera to night mode. Select **Color** to switch the camera to day mode. Sets the light sensor's sensitivity of switching between day mode and night mode. The value 10 is the most light-sensitive. Select **Trigger by Input** to switch between day mode and night mode once the input device (e.g. sensor or button) is triggered. For details, see *D/N, Special View Settings, 4.1.1 Video Settings*.
- **Denoise:** Reduces image noise especially under low-light conditions. The higher the denoise value, the stronger the effect.
- **Wide Dynamic Range:** adjusts and generates clear live view when the scene contains very bright and very dark areas at the same time. Select **Auto (Strong)** to bring out details in the dark areas of the scene, select **Auto (Weak)** to bring out less detail in the dark area and at the same time keep the bright areas from overexposure, or select **Auto (Normal)** for a balanced effect. Select **Close** to disable the function. This function is not available for GV-FER12203.

- **Defog:** Select **Auto** to automatically enhance the visibility of images. Select **Close** to disable the function. This function is not available for GV-FER12203.
- **Low Lux Enhancement:** Select **Auto** for the camera to automatically enhance the live view under insufficient light. Select **Close** to disable the function. The default setting is **Auto**. This function is only available for GV-FER12203.
- **Metering:** Controls the camera's exposure. Select **Normal** for the camera to adjust exposure based on the full live view. Select **Regional Metering** for the camera to adjust exposure of specified zones. Draw directly on the live view and a block marked with "AE (automatic exposure)" appears. You can establish up to 4 zones. To remove the block, right-click the block and select **Delete**.

[Temperature] Click the **Monitor** button to see the current temperature of the chipset in Celsius and Fahrenheit.

[Download] Allows you to install the programs from the hard drive.

Note: The I/O Control function is only supported by GV-FE2301 / 4301 and GV-FER12203.

3.2.4 Snapshot of a Live Video

To take a snapshot of live video, follow these steps:

1. Click the **Snapshot** button (No. 5, Figure 3-3). The Save As dialog box appears.
2. Specify **Save in**, type the **File name**, and select **JPEG** or **BMP** as **Save as Type**. You may also choose whether to display the name and date stamps on the image.
3. Click the **Save** button to save the image in the local computer.

3.2.5 Video Recording

You can record live video for a certain period of time to your local computer.

1. Click the **File Save** button (No. 6, Figure 3-3). The Save As dialog box appears.
2. Specify **Save in**, type the **File name**, and move the **Time period** scroll bar to specify the time length of the video clip from 1 to 5 minutes.
3. Click the **Save** button to start recording.
4. To stop recording, click the **Stop** button (No. 2, Figure 3-3).

3.2.6 Wide Angle Lens Dewarping

The fisheye source view is curved especially near the edges. Use this function to reduce the warping of live view.

1. Right-click on the live view to display a drop-down list.
2. Select **Wide Angle Setting**. The Wide Angle Dewarping Setting window appears.

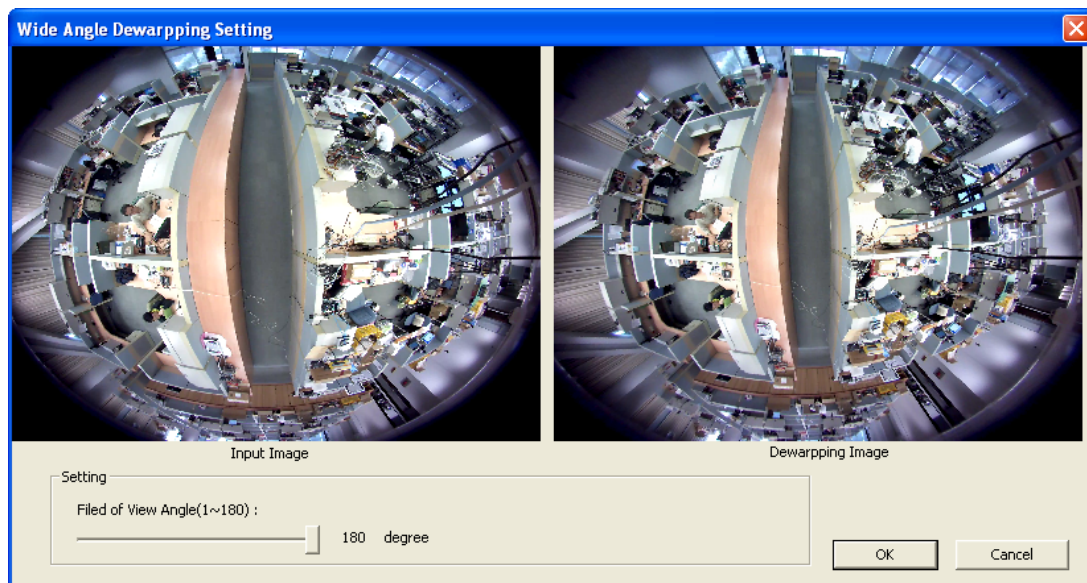

Figure 3-11

3. Slide the slider at the bottom to correct the degree of warping. The adjusted view is shown on the right. Click **OK** to close this window.
4. To enable this configuration, right-click on the live view, select **Wide Angle Lens Dewarping**.

Note: The Wide Angle Lens Dewarping function only applies to the circular source image.

3.2.7 Picture-in-Picture and Picture-and-Picture View

Two types of close-up views are available to provide clear and detailed images of the surveillance area: **Picture-in-Picture (PIP)** and **Picture-and Picture (PAP)**. After entering the live view window, the image is displayed in PIP mode by default. The PIP and PAP views can only be displayed on the hemispherical source image.

Picture-in-Picture View

With the Picture in Picture (PIP) view, you can crop the video to get a close-up view or zoom in on the video.

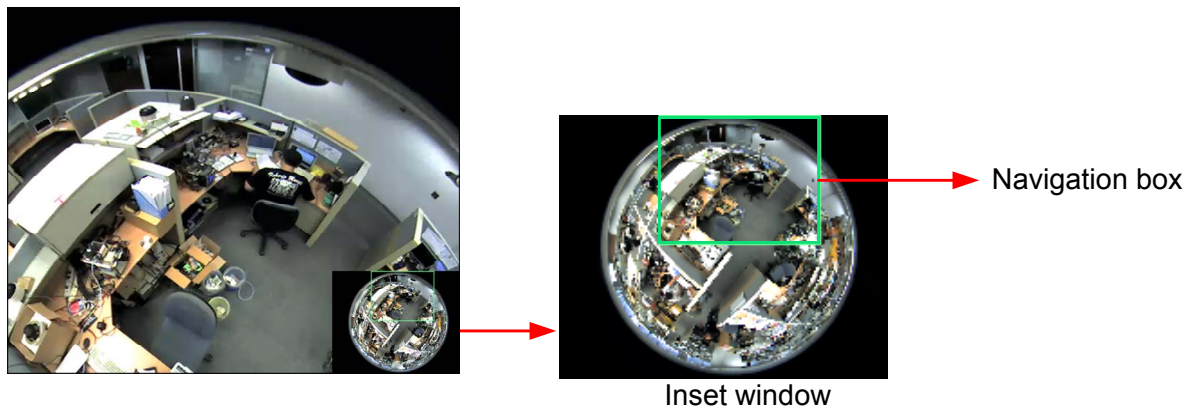

Figure 3-12

1. Right-click the live view and select **PIP**. An inset window appears.
2. Click the inset window. A navigation box appears.
3. Move the navigation box around in the inset window to have a close-up view of the selected area.
4. To adjust the navigation box size, move the cursor to any of the box corners, and enlarge or diminish the box.
5. To exit the PIP view, right-click the image and click **PIP** again.

Picture-and-Picture View

With the Picture and Picture (PAP) view, you can create a split video effect with multiple close-up views on the image. A total of 7 close-up views can be defined.

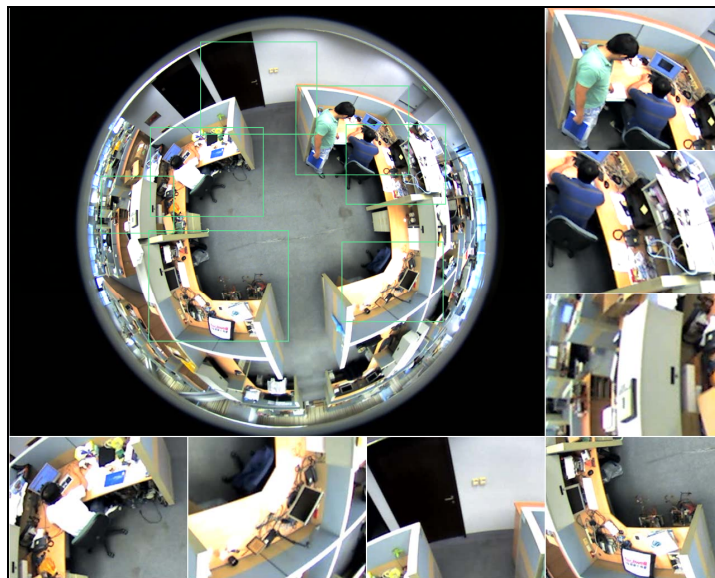

Figure 3-13

1. Right-click the live view and select **PAP**. A row of three inset windows appears at the bottom.
2. Draw a navigation box on the image, and this selected area is immediately reflected in one inset window. Up to seven navigation boxes can be drawn on the image.
3. To adjust a navigation box size, move the cursor to any of the box corners, and enlarge or diminish the box.
4. To move a navigation box to another area on the image, drag it to that area.
5. To change the frame color of the navigation box or hide the box, right-click the image, select **Mega Pixel Setting** and click one of these options:
 - **Display Focus Area of PAP Mode:** Displays or hides the navigation boxes on the image.
 - **Set Color of Focus Area:** Changes the color of the box frames.
6. To delete a navigation box, right-click the desired box, select **Focus Area of PAP Mode** and click **Delete**.
7. To exit the PAP view, right-click the image and click **PAP** again.

3.2.8 Object Tracking

You can track moving objects in fisheye live view. The function is only available when the fisheye camera mode is set to be **Geo Fisheye: 360 degree**. When motion is detected, the top-right channel will start tracking the moving object and in the 360 degree view at the bottom, the moving object will be highlighted.

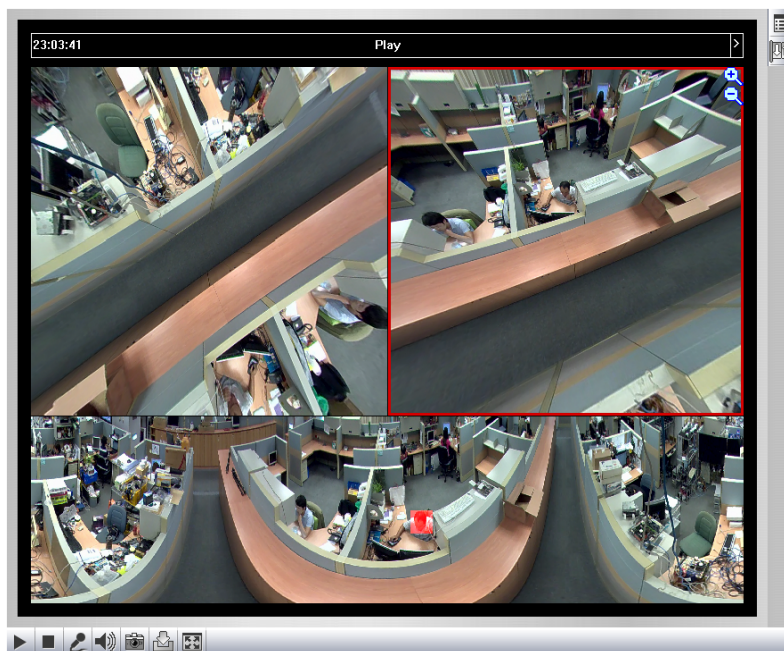

Figure 3-14

1. Right-click the fisheye view, select the camera number and select **Geo Fisheye**.
2. Right-click the fisheye view, select **Fisheye Option**, select **Camera Mode** and select **Geo Fisheye: 360 degree**.
3. Right-click the fisheye view, select **Fisheye Option**, select **360 Object Tracking** and select **Advanced Settings**. This dialog box appears.

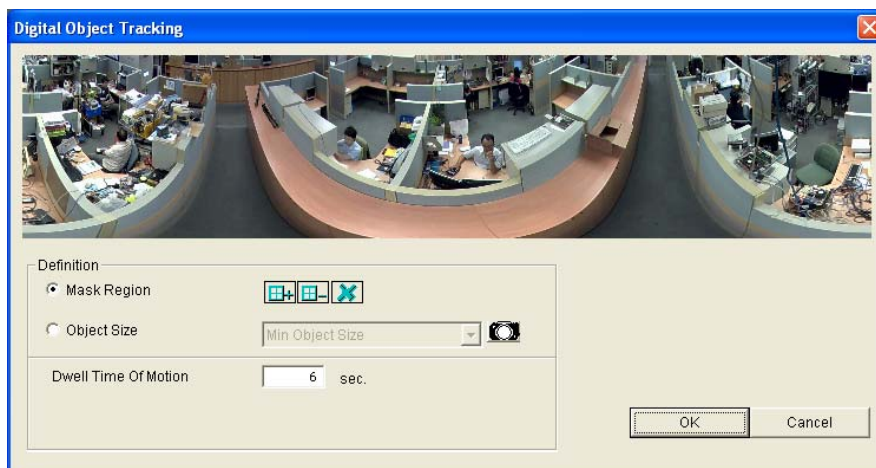



Figure 3-15

4. Use the options below to customize object tracking.
 - **Mask Region:** Use the mouse to outline a mask region where motion will be ignored.
 - **Object Size:** Click the  button to pause the live view and then use the mouse to outline the maximum and minimum size of the targeted object.
 - **Dwell Time of Motion:** After a targeted object stops moving, the highlighted region and the top-right channel will remain fixed on the area for the number of seconds specified. Any new motion detected during the dwell time will be ignored to prevent the camera view from frequently jumping from one area to another.
5. Right-click the fisheye view, select **Fisheye Option**, select **360 Object Tracking** and select **Tracking** to enable object tracking.

3.2.9 Alarm Notification

After input triggers and motion detection, you can be alerted by a pop-up live video and view up to four captured images.



Figure 3-16

To configure this function, click the **Show System Menu** button (No. 11, Figure 3-3), and select **Alarm Notify**. This dialog box appears.

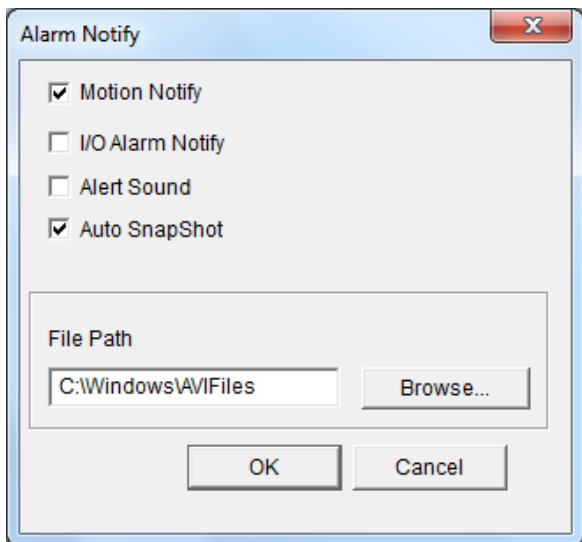

Figure 3-17

- **Motion Notify:** Once motion is detected, the captured images are displayed on the control panel of the Live View window.
- **I/O Alarm Notify:** Once the input device is triggered, the captured images are displayed on the control panel of the Live View window. For this function to work, the Administrator needs to install the input device properly. See 4.2.1 *Input Settings*.
- **Alert Sound:** Activates the computer alarm on motion and input-triggered detection.

- **Auto Snapshot:** The snapshot of live video is taken every 5 seconds on motion and input-triggered detection.
- **File Path:** Assigns a file path to save the snapshots.

Note:

1. The Administrator can adjust the motion detection area by using the Motion Detection function. See *4.1.3 Motion Detection* for more details.
 2. The I/O Alarm notification function is only supported by GV-FE2301 / 4301 and GV-FER12203.
-

3.2.10 Video and Audio Configuration

You can enable the microphone and speaker for two-way audio communication and set the number of frames to keep for live view buffer. Click the **Show System Menu** button (No. 9, Figure 3-3), and select **Video and Audio Configuration**.

- **Camera:** Sets the number of frames to keep in live view buffer. Keeping more frames for live view buffer can ensure a smooth live view, but the live view will be delayed for the number of frames specified.

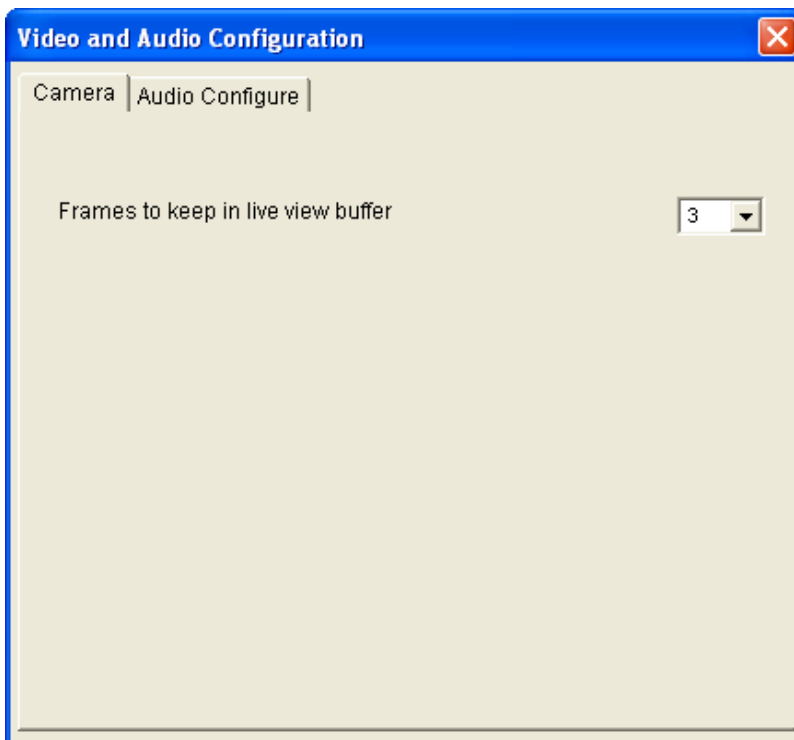

Figure 3-18

- **Audio Configure:** You can enable the microphone and speaker and adjust the audio volume.

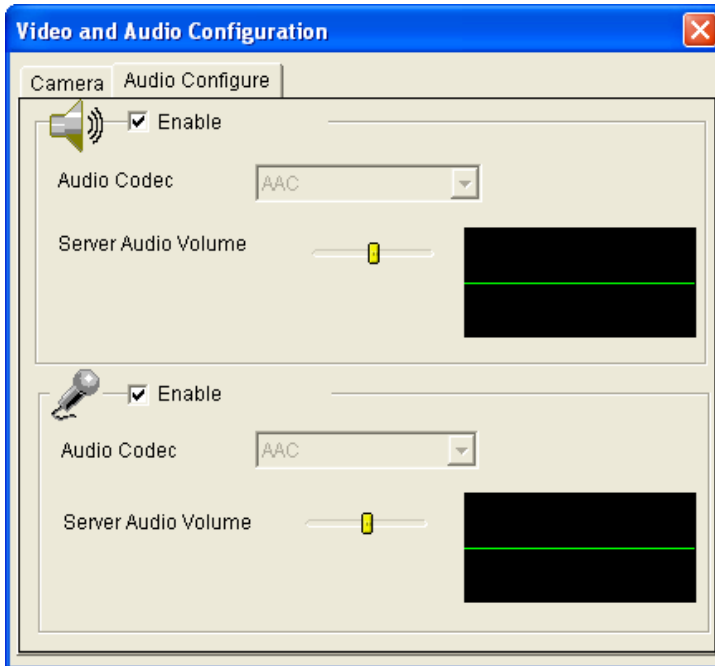

Figure 3-19

3.2.11 Remote Configuration

You can view the connection status of the central monitoring stations and upgrade firmware over the network. Click the **Show System Menu** button (No. 9, Figure 3-3), and select **Remote Config**. The Remote Config dialog box will appear.

[Firmware Upgrade] In this tab, you can upgrade the firmware over the network. For details, see *Chapter 6 Advanced Applications*.

3.2.12 Camera Name Display

To display the camera name on the image, click the **Show System Menu** button (No. 9, Figure 3-3), and select **Show Camera Name**.

3.2.13 Image Enhancement

To enhance the image quality of live video, click the **Show System Menu** button (No. 9, Figure 3-3), and select **Image Enhance**. This dialog box appears.

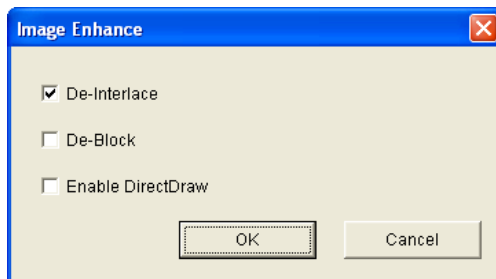

Figure 3-20

- **De-Interlace:** Converts the interlaced video into non-interlaced video.
- **De-Block:** Removes the block-like artifacts from low-quality and highly compressed video.
- **Enable DirectDraw:** Activates the DirectDraw function.

3.2.14 I/O Control

The I/O Control window provides real-time graphic displays of camera status, I/O status, and alarm events. Additionally, you can remotely force output to be triggered.

Note: I/O Control settings are only supported by GV-FE2301 / 4301 and GV-FER12203.

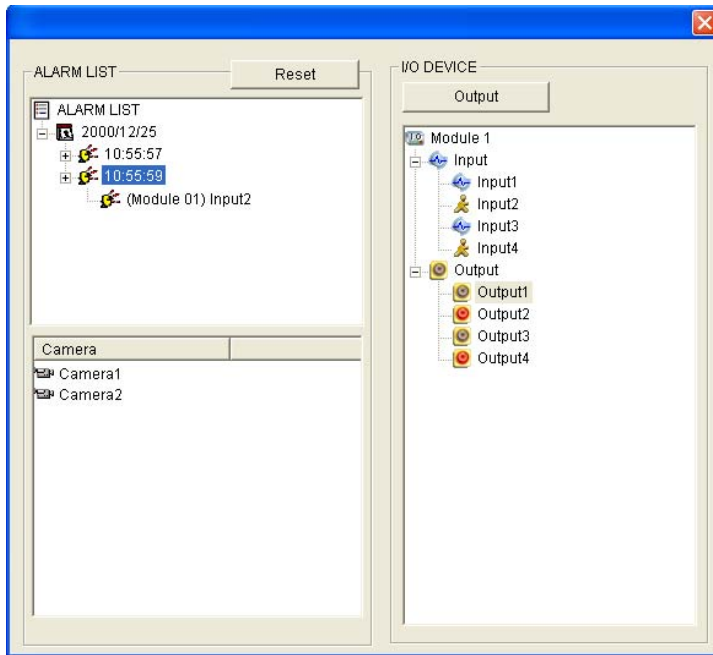

Figure 3-21

- To display the I/O control window, click the **I/O Control** button (No. 8, Figure 3-3).
- The Alarm List is displayed in three levels. The first level indicates date, the second indicates time, and the third indicates alarm ID. Clicking the **Reset** button will clear the list.
- To trigger an output device, highlight an output and then click the **Output** button.

3.2.15 Visual Automation

This function is only supported by GV-FE2301 / 4301 and GV-FER12203. The Visual Automation allows you to change the current state of the electronic device by simply clicking on its image, e.g. turning the light ON. This feature is only available when the Visual Automation is set ahead by the Administrator. For details, see *4.1.5 Visual Automation*



Figure 3-22

- To access this feature, click the **I/O Control** button (No. 8, Figure 3-3) and select **Visual Automation**.
- To change the style of the set areas, right-click the image and select **Visual Automation**. Right-click the image again to see these options:
 - **Show All:** Displays all set areas.
 - **Rect Float:** Embosses all set areas.
 - **Set Color:** Changes the frame color of all set areas.

3.2.16 Network Status

To view the network status, in the left menu, click **Network** and select **Status**.

Network Status Information	
In this section you can see an overview of GV-IPCAM status.	
Current Status Information	
interface:	Wired
IP Acquirement:	Fixed
MAC Address:	0013E201E1A1
IP Address:	192.168.2.115
Subnet Mask:	255.255.252.0
Gateway:	192.168.0.1
Domain Name Server 1:	192.168.0.1
Domain Name Server 2:	192.168.0.2

Figure 3-23

Chapter 4 Administrator Mode

The Administrator can access the system configuration through the network. Eight categories of configurations are involved in the system configuration: **Video and Motion**, **I/O Control**, **Events and Alerts**, **Monitoring**, **Recording Schedule**, **Remote ViewLog**, **Network** and **Management**.



Figure 4-1

List of Menu Options

Find the topic of interest by referring to the section number prefixed to each option.

4.1 Video and Motion	<ul style="list-style-type: none"> 4.1.1 Video Settings 4.1.2 Motion Detection 4.1.3 Privacy Mask 4.1.4 Text Overlay 4.1.5 Tampering Alarm 4.1.6 Visual Automation
4.2 I/O Control	<ul style="list-style-type: none"> 4.2.1 Input Setting 4.2.2 Output Setting
4.3 Events and Alerts	<ul style="list-style-type: none"> 4.3.1 Email 4.3.2 FTP 4.3.3 Center V2 4.3.4 Vital Sign Monitor 4.3.5 Backup Center 4.3.6 Video Gateway / Recording Server 4.3.7 ViewLog 4.3.8 RTSPONVIF
4.4 Monitoring	
4.5 Recording Schedule	<ul style="list-style-type: none"> 4.5.1 Recording Schedule Settings 4.5.2 I/O Monitor Settings
4.6 Remote ViewLog	
4.7 Network	<ul style="list-style-type: none"> 4.7.1 LAN 4.7.2 Wireless Client Mode 4.7.3 Advanced TCP/IP 4.7.4 UMTS Settings 4.7.5 IP Filtering 4.7.6 SNMP Settings
4.8 Management	<ul style="list-style-type: none"> 4.8.1 Date and Time Settings 4.8.2 Storage Settings 4.8.3 User Account 4.8.4 Log Information 4.8.5 Tools 4.8.6 Language

4.1 Video & Motion

The GV-Fisheye Camera can simultaneously process one video source in two different codec and resolutions. The dual-stream design benefits for lower bandwidth environment, allowing Streaming 2 to be set with lower resolution and codec for live streaming, and Streaming 1 set with highest resolution and codec H.264 for best recording quality. Two setting pages **Streaming 1** and **Streaming 2** are provided for separate setup.

Comparison between Streaming 1 and Streaming 2:

Video Setting Options	Streaming 1	Streaming 2
Region of Interest (ROI)	Yes	Not open for configuration. But settings in Streaming 1 are automatically applied to Streaming 2
Record Settings		
Watermark Setting		
LED Control		
Enable SDK		
Special View Setting		
Video Resolution	Yes. Different resolutions can be applied to Streaming 1 and Streaming 2.	

This section includes video image settings and how the images can be managed by using Motion Detection, Privacy Mask, Text Overlay, Tampering Alarm and Visual Automation.

4.1.1 Video Settings

Video Settings

In this section you can define compression art, broadcasting method and privacy mask.

Connection template

Customized

Video Signal Type

In this section you can configure camera's video signal, also the resolution and frame per second to be transmitted through the network

Video Format H264

Resolution	Frame per second
2048*1536 (4:3)	15

Bandwidth Management

In this section you can configure the bit rate used by video stream. When VBR (Variable Bit Rate) is selected, consistent image quality is achieved at the cost of varying bit rate. To set a consistent bit rate at the cost of varying image quality, select CBR (Constant Bit Rate).

VBR Quality Good Maximal Bit Rate 12 Mbit
 CBR Maximal Bit Rate 10240 Kbps

Region Of Interest (ROI)

In this section you can configure ROI of H.264.

Enable [ROI Setting](#)

GOP Structure and Length

In this section you can configure the composition of the video stream (GOP structure). Using I-Frame only will significantly increase the video quality as well as the bandwidth.

Group of Picture(GOP) Size 1.0 (seconds)

H264 Video Entropy Coding Setting

In this section you can decide Video entropy coding for H.264 codec

H.264 Entropy Encoding CAVLC

Record Settings

In this section you can configure pre-alarm and post-alarm settings.

Pre-alarm recording time 1 seconds

Post-alarm recording time 1 seconds with hard disk installed (1~30)

Split interval 5 minutes

Recording Profile Performance

Record audio

Write recording data into local storage
 (If disabled, the camera will stop recording to local storage while live view is accessed through Web browsers or other applications.)

Figure 4-2A

Text Overlay Settings

In this section you can set up texts to be overlaid on live view when viewing via GeoVision software.

Camera Name

Overlay with:

Camera Name

Date

System Time

Name of the associated digital input

Text Overlay Settings (OSD)

In this section you can set up texts to be overlaid on live view.

Camera Name

Font Size

Overlay with:

Camera Name

Date

System Time

Watermark Setting

In this section you can set Watermark function.

Enable

LED Control

Ready LED Enable Disable

Enable SDK

Enable

Special View Setting

Additional functions for Live View

D/N

<input checked="" type="radio"/>	Auto	Sensitivity 5
<input type="radio"/>	Black and White	
<input type="radio"/>	Color	

BLC Off On

Figure 4-2B

[Connection Template]

Select the type of your network connection. Unless you select **Customized**, this option will automatically bring up the recommended video resolution, frame rate, bandwidth and GOP size.

[Video Signal Type]

The codec options, resolutions and maximum frame rates are detailed below:

Models	Stream	Image Resolution	Maximum Frame Rate
GV-FE2301	Main	1440 x 1376	15 fps
	Sub	640 x 608	
GV-FE3402 / 3403 GV-FER3402 / 3403	Main	2048 x 1536	15 fps
	Sub	640 x 480	
GV-FE4301	Main	2048 x 1944	15 fps
	Sub	640 x 608	
GV-FE5302 / 5303 GV-FER5302 / 5303	Main	2560 x 1920	10 fps
	Sub	640 x 480	10 fps
GV-FER12203	Main	4000 x 3000	15 fps
	Sub	640 x 480	

[Bandwidth Management]

When using H.264, it is possible to control the bitrate, which in turn allows the amount of bandwidth usage to be controlled.

- **VBR (Variable Bitrate):** The quality of the video stream is kept as constant as possible at the cost of a varying bitrate. The bandwidth is used much more efficiently than a comparable CBR. You can set a limit to the bit rate by specifying a **Maximal Bit Rate**. Set the image quality to one of the 5 standards: **Standard, Fair, Good, Great, and Excellent**.
- **CBR (Constant Bitrate):** CBR is used to achieve a specific bitrate by varying the quality of the stream. Use the **Maximal Bit Rate** drop-down list to select a bitrate.

- **Smart Streaming:** When the option is enabled, the bitrates will be automatically reduced in static scenes, significantly maximizing bandwidth and lowering file size.

You can choose the image quality of **Static Scene** and **Dynamic Scene** to one of the 5 standards: **Standard**, **Fair**, **Good**, **Great** and **Excellent**. You can even choose the maximum bitrate to optimize the bandwidth.

Bitrate Reduction Level: The default value is 254. The bigger the value the more bitrates can be reduced in static scenes, thus saving the recording size.

Note: To enable **Smart Streaming** supported only by GV-FER12203 firmware V1.02 or later, it is required to use either GV-NVR V8.7 or GV-VMS V16.10.

[Region of Interest]

Defines clarity of different parts of the live view for the camera connecting to third-party software through ONVIF/RTSP. This function is disabled by default. Select **Enable** and click **ROI Setting** to configure:

1. On the popup window, use your mouse and draw directly on the live view to specify a region.

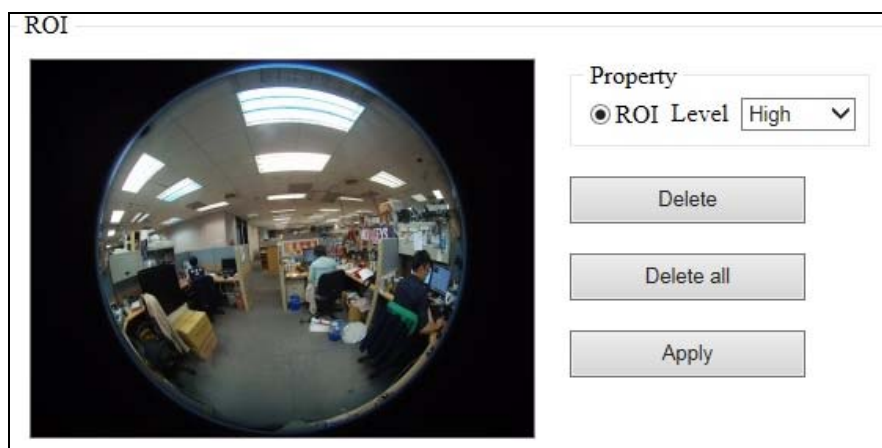

Figure 4-3

2. To define clarity to the region, select **ROI** and select **High**, **Medium** or **Low** using the drop-down list.
3. Click **Apply** to apply the configurations.

[GOP Structure and Length]

Use the **Group of Picture(GOP) Size** drop-down list to set the number of seconds between every key frame. This option is only available when H.264 is selected for codec.

[H.264 Video Entropy Coding Setting]

By default, the entropy coding is set to **CAVLC**. To change it to **CABAC**, click and select from the drop-down list. This function is not available for GV-FER12203.

[Record Settings] Note for **GV-FER12203** firmware V1.02 or later, see Recording Settings in *4.4 Monitoring* to adjust the setting.

The alarm settings allow you to capture images before and/or after the motion or I/O event happens.

- **Pre-alarm recording time:** Activates video recording before an event occurs. Set the recording time to 1 or 2 seconds. The recording is saved in the buffer of the camera.
- **Post-alarm recording time:** Activates video recording onto the inserted memory card after an event occurs. Set the recording time from 1 to 30 seconds.
- **Split Interval (Max. Video Clip):** Sets the maximum time length of each recorded file from 1 to 5 minutes.
- **Record Profile:** This setting is only applicable for recording to the camera's memory card. Select **Performance** to maximize the lifespan of the memory card by restricting the maximum bit rate to 4 Mbit and Sharpness value to 30. Select **Quality** to adopt your current settings.
- **Record Audio:** Activates audio recording when an event occurs.
- **Write recording data into local storage:** Select to continue recording to the local storage while live view is being accessed through Web interface or other applications such as GV-System / GV-VMS. This option is enabled by default.

Note: To optimize recording results, it is recommended to allow no more than two connections to the camera using Web interface or any other applications when **Write recording data into local storage** is enabled.

[Text Overlay Settings] Displays camera name, date, and/or time on the live view and recorded videos when viewing through GeoVision software.

- **Camera Name:** Type the camera name.

- **Overlay with:** Select one or more of the options below to be overlaid on the live view and recorded videos.
 - ⊙ **Camera Name**
 - ⊙ **Date**
 - ⊙ **System Time**
 - ⊙ **Name of the Associated Digital Input:** This function is only supported by GV-FE2301 / 4301 and GV-FER12203.

[Text Overlay Settings (OSD)] Displays camera name, date, and/or time on the live view and recorded videos when viewing through GeoVision software and third-party software through ONVIF and RTSP.

- **Name:** Type the camera name.
- **Font Size:** Select the font size using the drop-down list.
- **Overlay with:** Select one or more of the options below to be overlaid on the live view and recorded videos. Use the drop-down list to select the display position.
 - ⊙ **Camera Name**
 - ⊙ **Date**
 - ⊙ **System Time**

[Watermark] Enable this option to watermark all recordings. The watermark allows you to verify whether the recorded video has been tampered with. See *6.5 Verifying Watermark*.

[LED Control] Select **Disable** if you do not want to use the System Status LED (No. 8, Figure 1-2).

[Enable SDK] Select **Enable** to activate SDK. This function is not available for GV-FER12203.

[Special View Setting]

- **D/N:** Sets the Day/Night mode of the camera.
 - ⊙ **Auto:** Select **Auto** for the camera to detect the amount of light present and automatically switch to monochrome in a poorly-lit scene. Use the drop-down list to adjust the sensitivity level of light sensor from 1 to 10. The higher the value, the more sensitive the camera is to light.
 - ⊙ **Black and White:** Select this option for the live view to be in monochrome.

- ⊙ **Color:** Select this option for the live view to be in color.
- ⊙ **Trigger by Input:** Select this option to switch between day mode and night mode once the input device (e.g. sensor or button) is triggered.
- ⊙ **Schedule:** For GV-FER12201 firmware V1.02 or later, select this option to determine specific period(s) of time when day mode is activated. See *4.5 Recording Schedule Settings* for the details on the setting of the schedule.
- **[BLC]** Enable backlight compensation to adjust the exposure when the subject is positioned in front of a bright light source.
- **[IR Light]** Select **Auto** for automatic switch between day mode and night mode depending on the amount of light detected. Select **Off** to completely disable IR LEDs. This function is only supported by models with IR LEDs.

4.1.2 Motion Detection

Motion detection is used to generate an alarm whenever movement occurs in the video image. You can configure up to 8 areas with different sensitivity values for motion detection.

Motion Detection

In this section you can define different region(s) for motion detection.

To trigger digital output relay upon motions, be sure to set up the detection area on the Motion Detection page.





Camera

Sensitivity: 9

Motion Detection

Ignore environmental changes

Noise Tolerance

Set time interval: seconds

Advanced Setting

Please advise which action(s) should be taken when motion detection is activated.

Trigger digital output relay Output 1

Figure 4-4

The motion detection function is disabled by default. Follow the steps below to set up motion detection.

1. Select the desired sensitivity level by moving the slider. The higher the value, the more sensitive the camera is to motion.

2. Drag an area on the image. Click **Add** when you are prompted to confirm the setting.
3. To create several areas with different sensitivity values, repeat Steps 2 and 3.
4. Click **Save** to save the above settings.
5. Under Motion Detection section, select the following options to reduce false alarm.
 - **Ignore environmental changes:** Ignore environmental changes in the camera view such as rain or snow.
 - The **Noise Tolerance** function is enabled by default. It ignores video noise when the light intensity changes.
 - **Set Time Interval:** If you set a time interval, the duration of motion has to exceed the time interval for motion detection to be triggered.
 - **Set Duration:** Set a period of time for a motion to be recorded even if it lasts shorter than the specified time.
6. To trigger the alarm output when motion is detected, select **Output1** and click the **Apply** button. To activate the output settings, you must also start **Input** monitoring manually or by schedule. For related settings, see *4.4 Monitoring*.

Note:

1. The I/O settings are only available for GV-FE2301 / 4301 and GV-FER12203.
 2. **Set duration** is only supported by GV-FER12203 firmware V1.02 or later.
-

4.1.3 Privacy Mask

The Privacy Mask function is used to block out sensitive areas on live view and recorded clips for the camera connecting to GeoVision software. This feature is ideal for locations where displays, keyboard sequences (e.g. passwords), and for anywhere else you don't sensitive information visible.



Figure 4-5

1. Select the **Enable** option.
2. Drag the area(s) where you want to block out on the image. Click **Add** when you are prompted to confirm the setting.
3. Click the **Save** button to save the settings.

4.1.4 Text Overlay

The Text Overlay allows you to overlay any text in any place on the camera view. Up to 16 text messages can be created on one camera view. The overlaid text will be saved in the recordings.

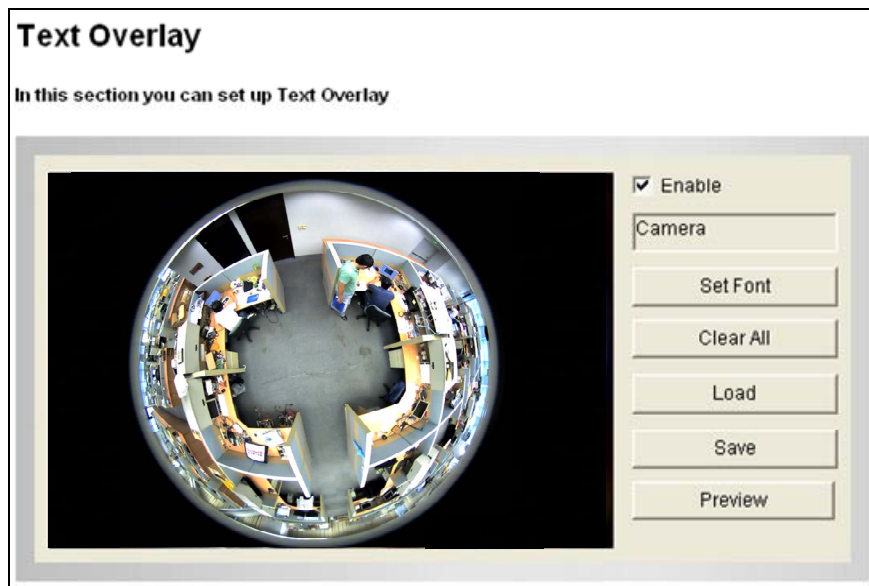

Figure 4-6

1. Select the font, font style and font size in a pop-up window.
2. Select the **Enable** option.
3. Click any place on the image. This dialog box appears.

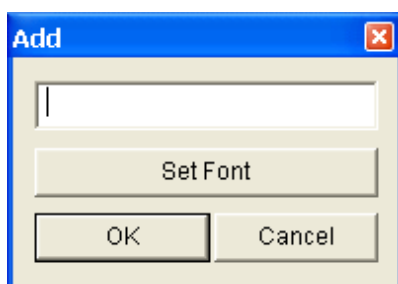

Figure 4-7

4. Type the desired text, and click **OK**. The text is overlaid on the image.
5. Drag the overlaid text to a desired place on the image.
6. Click **Set Font** to modify the font settings.
7. Click **Save** to apply the settings, or click **Load** (Undo) to revert to the last saved setting.
8. Click **Preview** to see how the text will appear on the image. Click **Close** to end the preview.

4.1.5 Tampering Alarm

The Tampering Alarm is used to detect when the camera is being physically tampered with. An alarm can be generated when the camera is moved, covered up, or out of focus. The alarm types include triggering the output device, e-mail alert and notifying the connected GV-Center V2, GV-Vital Sign Monitor, GV-System, and GV-VMS.

Note: Tampering Alarm with triggered output device is only supported by GV-FE2301 / 4301 and GV-FER12203.

To establish the tampering alarm, set up at least one of these alarm types properly.

- To trigger the output device when a tampering event occurs, enable the output setting and select **Tampering Alarm**. See *Output Setting* in 4.2.2 *Output Settings*.
- To trigger the e-mail alert when a tampering event occurs, enable the e-mail setting and select **Tampering Alarm**. See 4.3.1 *E-Mail*.
- To notify GV-Center V2, GV-Vital Sign Monitor, GV-System, and GV-VMS when a tampering event occurs, enable the connection to these systems. See 8.1 *Center V2*, 8.2 *Vital Sign Monitor* and 7.1 *Setting up GV-IP Cameras* respectively.

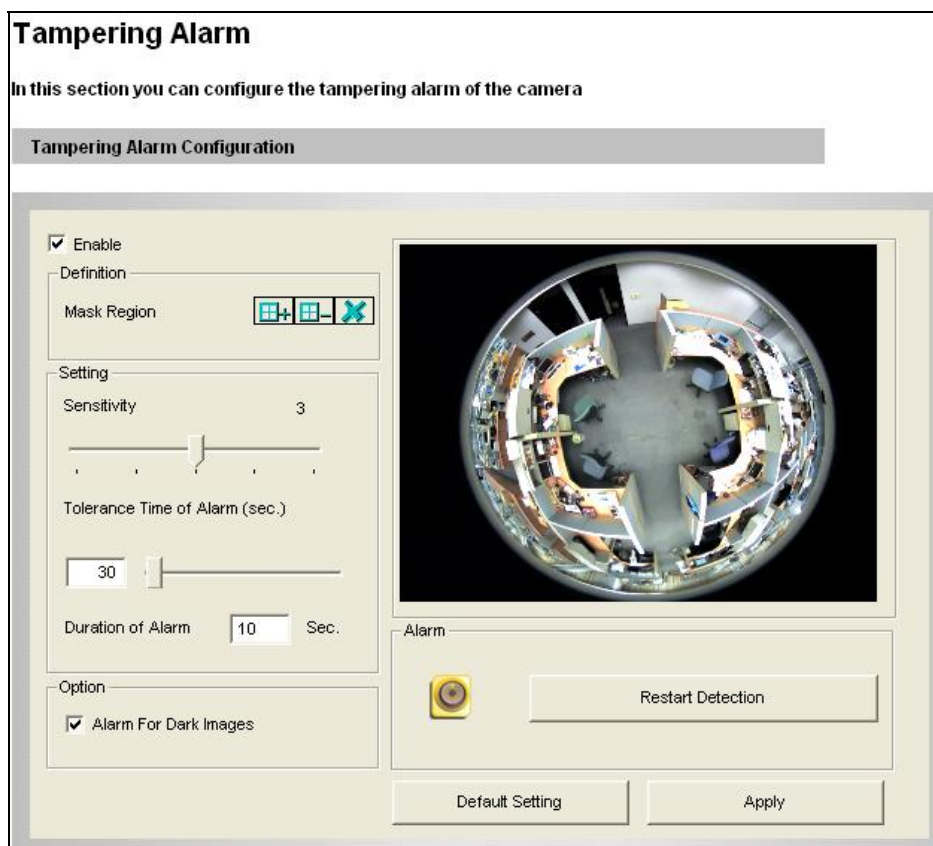



Figure 4-8

To configure the tampering alarm:

1. Select **Enable**.
2. If you want the camera to ignore any movement or scene change in certain areas, click the  button to drag areas on the camera view.
3. Select the desired detection sensitivity by moving the slider. The higher the value, the more sensitive the camera is to scene changes.
4. In the **Tolerance Time of Alarm** field, specify the time length allowed for scene changes before an alarm is generated.
5. In the **Duration of Alarm** field, specify the duration of the alarm after which the triggered output device will be turned off.
6. To trigger an alarm when the scene turns dark, e.g. when the lens of camera is covered, make sure the **Alarm for Dark Images** option is enabled. By default, this option is enabled.
7. Click **Apply** to save all the settings.
8. Start monitoring to enable the function. To have output alarm, it is required to start **Input** monitoring. See *4.4 Monitoring*.

When the camera has been tampered with, the output device can be activated. To turn off the output device immediately, return to this setting page, and click **Restart Detection**.

4.1.6 Visual Automation

This intuitive feature helps you automate any electronic device by triggering the connected output device. When you click on the image of the electronic device, you can change its current state, e.g. turning the light on.

Note: Visual Automation settings are only supported by GV-FE2301 / 4301 and GV-FER12203.

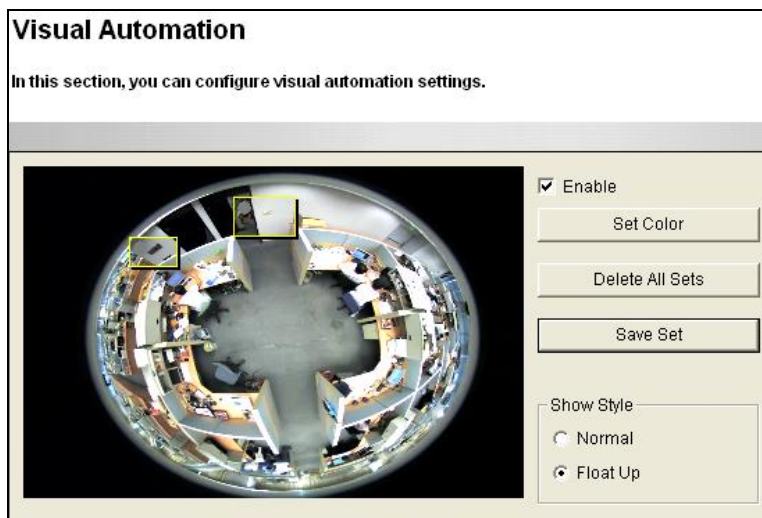

Figure 4-9

1. Select the **Enable** option.
2. Drag an area on the image of the electronic device. This dialog box appears.

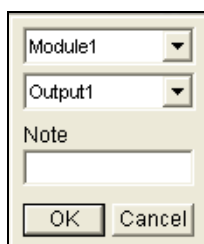

Figure 4-10

3. Assign the connected module and output device. In the Note field, type a note to help you identify the device. Click **OK** to save the settings.
4. To change the frame color of the set area, click the **Set Color** button.
5. To emboss the set area, select **Float Up**; or keep it flat by selecting **Normal**.
6. Click the **Save Set** button to apply the settings.

To perform the function, see 3.2.15 *Visual Automation*.

4.2 I/O Control

The I/O wires connected to the camera provide the interface for one input device and one output device.

Note: The I/O settings are only supported by GV-FE2301 / 4301 and GV-FER12203.

4.2.1 Input Settings

To activate the sensor input, select **Enable**.

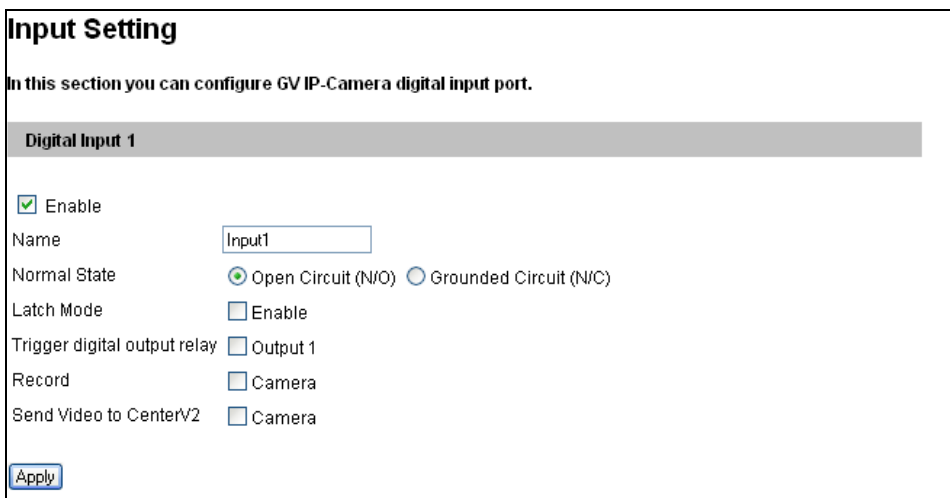

The screenshot shows a web-based configuration window titled "Input Setting". Below the title, it states: "In this section you can configure GV IP-Camera digital input port." There is a section header "Digital Input 1" with a grey background. Below this, there are several configuration options:

- Enable
- Name:
- Normal State: Open Circuit (N/O) Grounded Circuit (N/C)
- Latch Mode: Enable
- Trigger digital output relay: Output 1
- Record: Camera
- Send Video to CenterV2: Camera

An "Apply" button is located at the bottom left of the configuration area.

Figure 4-11

- **Normal State:** You can set the input state to trigger actions by selecting **Open Circuit (N/O)** or **Grounded Circuit (N/C)**.
- **Latch Mode:** Enable this option to have a momentary output alarm.
- **Trigger digital output relay:** When this option is enabled, the output will be triggered once the input is activated.
- **Record:** Enable this option to start recording when the input is triggered.
- **Send Video to Center V2:** Enable this option to send the images to Center V2 when the input is triggered.

Note: Triggering the output, recording the images and sending video to Center V2 are enabled only after you start **Input** monitoring manually or by schedule. To configure the input monitoring, see [4.4 Monitoring](#).

4.2.2 Output Settings

Select **Enable** to start the output device. Choose the output signal that best suits the device you are using: N/O (Open Circuit), N/C (Grounded Circuit), N/O Toggle, N/C Toggle, N/O Pulse or N/C Pulse. For **Toggle** output type, the output continues to be triggered until a new input trigger ends the output. For **Pulse** output type, the output is triggered for the amount of time you specify in the Trigger Pulse Mode for x Seconds field.

[Alarm Settings] You can choose to automatically trigger the digital output under these conditions: tampering alarm, disk write error (Rec Error) and hard disk full (HD Full).

Output Setting

In this section you can configure GV IP-Camera digital output port.

Digital Output 1 - Normal State

Enable

Name

General Mode Open Circuit (N/O) Grounded Circuit (N/C)

Toggle Mode Open Circuit (N/O) Grounded Circuit (N/C)

Pulse Mode Open Circuit (N/O) Grounded Circuit (N/C)

Trigger Pulse Mode for seconds(1~60)

Digital Output 1 - Alarm Settings

Tampering Alarm

Rec Error

HD Full

Figure 4-12

4.3 Events & Alerts

The Administrator can set up the following alert methods to receive notifications when motion is detected or I/O devices are triggered:

1. Send a captured still image by e-mail or FTP.
2. Notify Center Monitoring Station, Center V2, Vital Sign Monitor or GV-GIS, by video or text alerts.

To activate the above alert methods, you must set the following functions in advance:

- Motion Detection (See 4.1.2 *Motion Detection*)
- Input Setting (See 4.2.1 *Input Settings*)
- For e-mail and FTP alerts, it is required to start monitoring (See 4.4 *Monitoring*).

4.3.1 E-mail

After a trigger event, the camera can send an e-mail to a remote user containing a captured still image.

Email

In this section you can configure mailserver (SMTP) to handle events, videos, and error messages.

Primary mail server

Enable

Server URL/IP Address

Server Port

From email address

Send to (Please use "," to separate recipient's address)

Alerts Interval time in minute (0 to 60)

Need authentication to login

User Name

Password

This server requires a secure connection (SSL)

Email - Alarm Settings

Tampering Alarm

Rec Error

HD Full

Motion Detection

Digital Input

Figure 4-13

[Enable] Select to enable the e-mail function.

- **Sever URL/IP Address:** Type the SMTP Server's URL address or IP address.
- **Server Port:** Type the SMTP Server's port number. Or keep the default value 25.
- **From email address:** Type the sender's e-mail address.
- **Send to:** Type the e-mail address(s) you want to send alerts to.
- **Alerts Interval Time:** Specify the interval between e-mail alerts. The interval can be between 0 and 60 minutes. The option is useful for frequent event occurrence. Any event triggers during the interval period will be ignored.

[Need authentication to login] If the SMTP Server needs authentication, select this option and type a valid username and password to log in the SMTP server.

[This server requires a secure connection] If the SMTP Servers needs a secure connection (SSL), select this option.

[Email-Alarm Settings] You can choose to automatically send an e-mail alert under these conditions: motion detection, digital input triggered, tampering alarm, disk write error (Rec Error) and hard disk full (HD Full). Note that e-mail notification upon input trigger is only supported by GV-FE2301 / 4301 and GV-FER12203.

Important: To send e-mail alert upon motions, be sure to set up the detection area on the [Motion Detection page](#).

For settings related to sending e-mail alerts, see *4.1.2 Motion Detection*, *4.2.2 Output Settings* and *4.4 Monitoring*.

4.3.2 FTP

You can also send the captured images to a remote FTP server as alerts.

FTP Client and Server Setting

In this section you can configure a ftp server (File Transfer Protocol) to handle events, videos, and error messages.

To notify the FTP Server upon motions, be sure to set up the detection area on the [Motion Detection page](#).

Upload to a FTP server

Enable

Passive Mode Active Mode

Server URL/IP Address

Server Port

User Name

Password

Remote Directory

Alerts Interval time in minute (0 to 60)

FTP - Alarm Settings

Motion Detection

Continuously send images upon trigger events(Motion)

Digital Input

Continuously send images upon trigger events (Input)

Continuously send images

Interval

Enable recycling, Keep days (1-255)

Act as FTP server

In this section you can enable/disable GV-IPCAM internal ftp server for file transfer.

Enable ftp access to GV-IPCAM

Use alternative Port

Figure 4-14

[Upload to an FTP Server]

- **Enable:** Select to enable the FTP function and then select **Active Mode** or **Passive Mode**, depending on the setting of your FTP server.
- **Server URL/IP Address:** Type the URL address or IP address of the FTP Server.
- **Server Port:** Type the port number of the FTP Server. Or keep the default value 21.

- **User Name:** Type a valid user name to log into the FTP Server.
- **Password:** Type a valid password to log into the FTP Server.
- **Remote Directory:** Type the name of the storage folder on the FTP Server.
- **Alerts Interval time in minute:** Specify the interval between FTP alerts. The interval can be between 0 and 60 minutes. The option is useful for frequent event occurrence. Any event triggers during the interval period will be ignored.

[FTP-Alarm Settings]

- **Motion Detection:** Once motion is detected on the camera, a still image will be sent to the FTP Server.
 - ⊙ **Continuously send images upon trigger events (Motion):** A sequence of snapshots is uploaded to the FTP Server when motion is detected on the camera.
- **Digital Input:** When the input is triggered, a still image will be sent to the FTP Server.
 - ⊙ **Continuously send images upon trigger events (Input):** A sequence of snapshots is uploaded to the FTP Server when the input is triggered.
- **Continuously send images:** Send messages to the FTP server at the specified interval.
 - ⊙ **Interval: Interval:** Use the drop-down list to specify how frequent the images are sent to the FTP server.
 - ⊙ **Enable Recycling:** Select this option to recycle the FTP storage at the specified Keep Day.
 - ⊙ **Keep Days:** Specify the number of days after which the images at the FTP server are recycled. By default, the Keep Day is set to 1.

Important:

1. To send FTP alert upon motions, be sure to set up the detection area on the [Motion Detection page](#).
 2. Digital Input settings are only supported by GV-FE2301 / 4301.
-

[Act as FTP Server]

- **Enable FTP access to GV-IPCAM:** The camera acts as an FTP server, enabling users to download AVI files. The memory card must be inserted for the camera to act as an FTP server.
- **Use alternative port:** The default port is set to 21.

To access the internal FTP server through a web browser, type the IP address or the domain name of the camera in your browser like this:

ftp://192.168.0.10

When prompted for Username and Password, type the default username **ftpuser** and the default password **123456**. Then you should find the AVI files recorded after trigger events.

To change login information of the internal FTP server, see *4.8.3 User Account*. For the related settings to send FTP alerts, see *4.1.2 Motion Detection*, *4.2.1 Input Settings* and *4.4 Monitoring*.

4.3.3 Center V2

After a motion or an I/O triggered event, the central monitoring station Center V2 can be notified by live videos and text alerts. For the live monitoring through Center V2, you must already have a subscriber account on Center V2. The camera can connect with up to two Center V2.

Important:

1. To notify the Center V2 Server upon motions, be sure to set up the detection area on the [Motion Detection](#) page.
2. The input trigger function is only supported by GV-FE2301 / 4301 and GV-FER12203.

Connection 1
Connection 2

Center V2

In this section you can configure the connection to Center V2 and tasks to perform.

Center V2 server

Activate Link

Host name or IP Address:

Port number:

User Name:

Password:

Cease motion detection messages from Camera

Cease input trigger message from Input 1

Enable schedule mode

Select schedule time

Span 1 : : : Next Day

Span 2 : : : Next Day

Span 3 : : : Next Day

Weekend Saturday and Sunday Only Sunday

Connection Status

Status: Connected. Connected Time: Wed May 26 04:31:30 2010

Figure 4-15

To enable the Center V2 connection:

1. **Activate Link:** Enable the monitoring through Center V2.
2. **Host Name or IP Address:** Type the host name or IP address of Center V2.
3. **Port Number:** Match the port to **Port 2** on Center V2. Or keep the default value 5551. For details, see *8.1 Center V2*.
4. **User Name:** Type a valid user name to log into Center V2.
5. **Password:** Type a valid password to log into Center V2.
6. Click **Apply**. The Connection Status should display “Connected” and the connected time.
7. To establish the connection to the second Center V2, click the **Connection 2** tab and repeat the above steps for setup.

These options can also be found on this Center V2 setting page:

- **Cease motion detection messages from:** Stops notifying Center V2 of motion-triggered events.
- **Cease input trigger messages from:** Stops notifying Center V2 of input-triggered events.
- **Enable schedule mode:** Starts the monitoring through Center V2 based on the schedule you set in the **Select Schedule Time** section. Refer to *4.5 Recording Schedule* for the same settings.

For related settings to activate the monitoring through Center V2, see *4.1.2 Motion Detection*, *4.2.1 Input Settings*, and *8.1 Center V2*.

4.3.4 Vital Sign Monitor

After a motion detection or an I/O triggered event, the central monitoring station Vital Sign Monitor can get notified by text alerts. For the live monitoring through Vital Sign Monitor, you must already have a subscriber account on Vital Sign Monitor. The camera can be connected with up to two Vital Sign Monitor.

Important:

1. To notify the Vital Sign Monitor upon motions, be sure to set up the detection area on the Motion Detection page.
2. Input trigger is only available for GV-FE2301 / 4301 and GV-FER12203.

Connection 1
Connection 2

Vital Sign Monitor Server Setting

In this section you can configure the connection to VSM Server and tasks to perform.

Vital Sign Monitor Server

Activate Link

Host name or IP Address:

Port number:

User Name:

Password:

Cease motion detection messages from Camera

Cease input trigger message from Input 1

Enable schedule mode

Select schedule time

Span 1 : ~ : Next Day

Span 2 : ~ : Next Day

Span 3 : ~ : Next Day

Weekend Saturday and Sunday Only Sunday

Special Day (MM/DD)

01. <input style="width: 30px;" type="text"/>	02. <input style="width: 30px;" type="text"/>	03. <input style="width: 30px;" type="text"/>	04. <input style="width: 30px;" type="text"/>
05. <input style="width: 30px;" type="text"/>	06. <input style="width: 30px;" type="text"/>	07. <input style="width: 30px;" type="text"/>	08. <input style="width: 30px;" type="text"/>
09. <input style="width: 30px;" type="text"/>	10. <input style="width: 30px;" type="text"/>	11. <input style="width: 30px;" type="text"/>	12. <input style="width: 30px;" type="text"/>

Connection Status

Figure 4-16

To enable the Vital Sign Monitor connection:

1. **Activate Link:** Enable the monitoring through Vital Sign Monitor.
2. **Host Name or IP Address:** Type the host name or IP address of Vital Sign Monitor.
3. **Port Number:** Match the port to **Port 2** on Vital Sign Monitor. Or keep the default value 5609. For details, see *8.2 Vital Sign Monitor*.
4. **User Name:** Type a valid user name to log into Vital Sign Monitor.
5. **Password:** Type a valid password to log into Vital Sign Monitor.
6. Click **Apply**. The Connection Status should display “Connected” and connected time.
7. To establish the connection to the second Vital Sign Monitor, click the **Connection 2** tab and repeat the above steps for setup.

These options you can also find on this Vital Sign Monitor setting page:

- **Cease motion detection messages from:** Stops notifying Vital Sign Monitor of motion-triggered events.
- **Cease input trigger messages from:** Stops notifying Vital Sign Monitor of input-triggered events.
- **Enable schedule mode:** Starts the monitoring through Vital Sign Monitor based on the schedule you set in the **Select Schedule Time** section. Refer to *4.5 Recording Schedule* for the same settings.

For related settings to activate the monitoring through Vital Sign Monitor, see *4.1.2 Motion Detection*, *4.2.1 Input Settings*, and *8.2 Vital Sign Monitor*.

4.3.5 Backup Center

The connection to the GV-Backup Center allows you to back up another copy of recordings to the GV-Backup Center on an offsite location while the camera is saving these data to the memory card. The GV-Backup Center provides a PC-based storage and backup solution. For details on the GV-Backup Center, see *GV-Backup Center User's Manual*.

Backup Center

In this section you can configure the connection to Backup Center and tasks to perform

Backup Center

Activate Link

Host name or IP Address:

Port number:

User Name:

Password:

Backup Video

Compact Video

Resend all files

Automatic Failover Support

Host name or IP Address:

Port number:

User Name:

Password:

Enable schedule mode

Select schedule time

Span 1 : ~ : Next Day

Span 2 : ~ : Next Day

Span 3 : ~ : Next Day

Weekend Saturday and Sunday Only Sunday

Connection Status

Status: Disconnected

Figure 4-17

To enable connection to Backup Center:

1. **Activate Link:** Enable the connection to the Backup Center.
2. **Host Name or IP Address:** Type the host name or IP address of the Backup Center.
3. **Port Number:** Match the communication port on the Backup Center. Or keep the default value 30000.
4. **User Name:** Type a valid user name to log into the Backup Center.
5. **Password:** Type a valid password to log into the Backup Center.
6. **Backup Video:** Select the streams to back up their recordings to the Backup Center.
7. **Compact Video:** Select the streams to only back up their Key Frames to the Backup Center, instead of full recordings. This option is useful to save the backup time.
8. **Resend all files:** Select this option to send all the recorded files that have been received by the Backup Center again.
9. **Enable Schedule Mode:** Enable the Backup Center connection on the schedule you set in the **Select Schedule Time** section. Refer to *4.5 Recording Schedule* for the same settings.
10. Click **Apply**. The Connection Status should display “Connected” and connected time.

If the Backup Center has a failover server to provide uninterrupted backup services in case the primary Backup Center fails, you can enable the automatic failover support.

1. **Automatic Failover Support:** Enable automatic connection to a secondary failover server once the connection between camera and the primary Backup Center is interrupted.
2. **Host Name or IP Address:** Type the host name or IP address of the failover center.
3. **Port Number:** Match the communication port on the failover server. Or keep the default value 30000.
4. **User Name:** Type a valid user name to log into the failover server.
5. **Password:** Type a valid password to log into the failover server.
6. Click **Apply**.

4.3.6 Video Gateway / Recording Server

The GV-Video Gateway / GV-Recording Server is a video streaming server designed for large-scale video surveillance deployments. The GV-Video Gateway / GV-Recording Server (with recording capability) can receive up to 128 channels from various IP video devices, and distribute up to 300 channels to its clients. With the GV-Video Gateway / GV-Recording Server, the desired frame rate can be ensured while the CPU loading and bandwidth usage of the IP video devices are significantly reduced.

The fisheye camera can be connected with up to two GV-Video Gateway / GV-Recording Server. To send the video images to the GV-Video Gateway or GV-Recording Server, follow the steps below.

Connection 1
Connection 2

Video Gateway / Recording Server

In this section you can configure the connection to Video Gateway / Recording Server.

To notify the Video Gateway/Recording Server upon motions, be sure to set up the detection area on the Motion Detection page.

Video Gateway / Recording Server

Activate Link

Host name or IP Address:

Port number:

User Name:

Password:

Enable schedule mode

Select schedule time

Span 1 : ~ : Next Day

Span 2 : ~ : Next Day

Span 3 : ~ : Next Day

Weekend Saturday and Sunday Only Sunday

Connection Status

Status: Disconnected

Figure 4-18

1. **Activate Link:** Enable the connection to the GV-Video Gateway / GV-Recording Server.
2. **Host Name or IP Address:** Type the host name or IP address of the GV-Video Gateway / GV-Recording Server.
3. **Port Number:** Match the communication port on the GV-Video Gateway / GV-Recording Server or keep the default value 50000.
4. **User Name:** Type a valid user name to log into the GV-Video Gateway / GV-Recording Server.
5. **Password:** Type a valid password to log into the GV-Video Gateway / GV-Recording Server.
6. **Enable schedule mode:** Enable the GV-Video Gateway / GV-Recording Server connection on the schedule you set in the **Select Schedule Time** section. Refer to *4.5 Recording Schedule* for the same settings.
7. Click **Apply**. The Connection Status should display “Connected” and the connected time.
8. To establish the connection to the second GV-Video Gateway / GV-Recording Server, click the **Connection 2** tab and repeat the above steps for setup.

4.3.7 ViewLog Server

The ViewLog Server is designed for remote playback function. This server allows you to remotely access the recorded files saved in the camera and play back video with the player ViewLog.

Select **Enable** to activate the built-in server. Keep the default port **5552** or modify it if necessary. For details on the remote playback, see *5.2.2 Playback over Network*.

Viewlog Server Settings

In this section you can configure the connection to Viewlog Server and tasks to perform.

Viewlog Server

Enable	<input checked="" type="checkbox"/>
Port number:	<input type="text" value="5552"/>

Figure 4-19

4.3.8 RTSP/ONVIF

The RTSP Server enables RTSP protocol for video streaming.

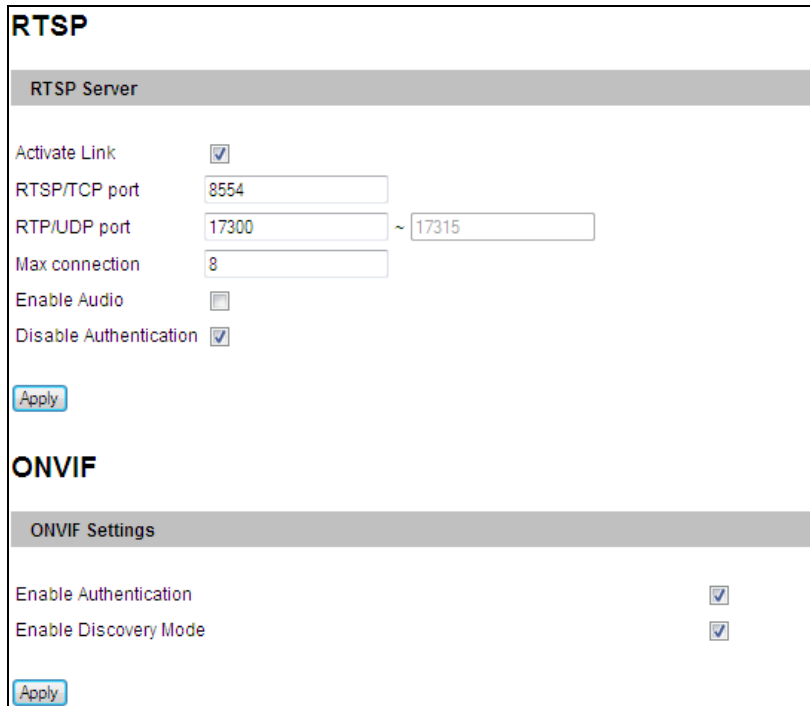

RTSP

RTSP Server

Activate Link

RTSP/TCP port

RTP/UDP port ~

Max connection

Enable Audio

Disable Authentication

ONVIF

ONVIF Settings

Enable Authentication

Enable Discovery Mode

Figure 4-20

[RTSP]

- **Activate Link:** Enable the RTSP protocol.
- **RTSP/TCP Port:** Keep the default value 8554, or modify it if necessary.
- **RTP/UDP Port:** Keep the default range from 17300 to 17319, or modify it if necessary. The number of ports for use is limited to 20.
- **Max Connection:** Set the maximum number of connections to the camera. The maximum value is 8.
- **Enable Audio:** Turns audio streaming on or off.
- **Disable Authentication:** Note this option is not supported by GV-FE2301 / 4301 (firmware version 1.10 or earlier). By default, when accessing live view through RTSP command, the ID and password of the camera are required. Select this option to disable the authentication prompt.

For details on the RTSP command, see *RTSP Protocol Support* in Appendix B.

[ONVIF]

- **Enable Authentication:** The ID and password of the camera are required to access the camera by a third-party DVR through ONVIF. This function is enabled by default.
- **Enable Discovery Mode:** Allows the third-party DVR to browse this camera. This function is enabled by default.

4.4 Monitoring

You can start recording manually, by schedule or by input trigger.

Note:

1. See **Note for Recording** at the beginning of the manual.
2. Recording upon input trigger is only supported by GV-FE2301 / 4301 and GV-FER12203.

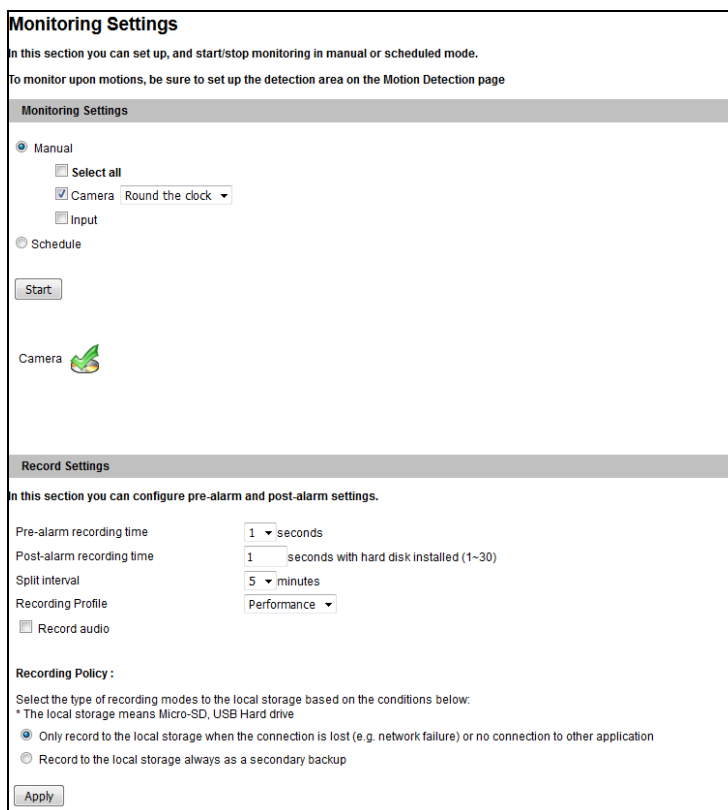

Figure 4-21

[Manual] Manually activates motion detection and I/O monitoring. Select one of the following options and then click the **Start** button.

- **Select all:** Manually starts both motion detection and I/O monitoring.
- **Camera Round the clock / Motion:** Manually starts recording. Select the desired recording mode for recording.
- **Input:** Manually starts I/O monitoring. When the sensor input is triggered, the camera and output will also be activated for recording and alerting. For input settings, see *4.2.1 Input Settings*.

[Schedule] The system starts recording and input monitoring based on the schedule you set. For schedule settings, see *4.5 Recording Schedule*.

[Camera Status Icon]

: On standby



: Enabled for motion detection and input trigger



: Recording is on.

[Recording Settings] Note this function is only supported by **GV-FER12203** firmware V1.02 or later. Configure recording settings for motion and I/O events, and the condition to record.

- **Pre-alarm recording time:** Activates video recording before an event occurs. Set the recording time to 1 or 2 seconds. The recording is saved in the buffer of the camera.
- **Post-alarm recording time:** Activates video recording onto the inserted memory card after an event occurs. Set the recording time from 1 to 30 seconds.
- **Split-interval:** Sets the time length between each event file from 1 to 5 minutes.
- **Recording Profile:** This setting is only applicable for recording to the camera's memory card. Select **Performance** to maximize the lifespan of the memory card by restricting the frame rate to 30 fps and maximum bit rate to 4 Mbit. Select **Quality** to adopt your current settings. The default setting is **Performance**.
- **Record audio:** Activates audio recording when an event occurs.
- **Recording Policy:** By default, the camera will only record to the memory card when the camera is not streaming live view to other applications (e.g. GV-VMS) or Web browser. Alternatively, you can set the camera to always record to the memory card as a secondary backup.

Note: When the camera is recording to the memory card, it is recommended to connect no more than two connections to the camera using Web interface or other applications

4.5 Recording Schedule

The schedule is provided to activate recording and I/O monitoring on a specific time each day.

4.5.1 Recording Schedule Settings

You can set up the schedule for recording.

Recording Schedule Settings

In this section you can configure schedule time.

Select schedule time

<input checked="" type="checkbox"/> Span 1	Motion	00	:00	~	09	:00	
<input checked="" type="checkbox"/> Span 2	Round the clock	09	:00	~	18	:00	
<input checked="" type="checkbox"/> Span 3	Motion	18	:00	~	00	:00	Next Day
<input type="checkbox"/> Weekend	Round the clock	<input checked="" type="radio"/> Saturday and Sunday <input type="radio"/> Only Sunday					
<input type="checkbox"/> Special Day	Round the clock	(MM/DD)					
	01.	02.	03.	04.			
	05.	06.	07.	08.			
	09.	10.	11.	12.			

Figure 4-22

- **Span 1- Span 3:** Set a different recording mode for each time span during the day. Each day can be divided into 3 time spans, shown as Span 1, Span 2, and Span 3. The time span settings will apply to Monday through Sunday.
- **Weekend:** Enable this option to start monitoring all day on the weekend and select a recording mode to be used. Define whether your weekend includes **Saturday and Sunday** or **Only Sunday**.
- **Special Day:** Set the recording mode on a specified day.

4.5.2 I/O Monitoring Settings

You can set the schedule for I/O monitoring to start.

Note: The I/O Monitoring Settings are only supported for GV-FE2301 / 4301 and GV-FER12203.

I/O Monitor Settings

In this section you can configure I/O monitor time.

Select monitor time

Span 1 00:00 ~ 07:00

Span 2 19:00 ~ 00:00 Next Day

Span 3 00:00 ~ 00:00 Next Day

Weekend Saturday and Sunday Only Sunday

Special Day (MM/DD)

01. 02. 03. 04.

05. 06. 07. 08.

09. 10. 11. 12.

Apply

Figure 4-23

- **Span 1-3:** Set different time spans during the day to enable I/O monitoring. Each day can be divided into 3 time spans, shown as Span 1, Span 2, and Span 3. The time span settings will work from Monday through Sunday.
- **Weekend:** Enable this option to start I/O monitoring all day on the weekend and select whether your weekend includes **Saturday and Sunday** or **Only Sunday**.
- **Special Day:** Enable I/O monitoring on a specified day.

Note: In Recording Schedule and I/O Monitoring Schedule, if the settings for Special Day conflict with those for Span 1-3 or Weekend, the Special Day settings will get priority.

4.6 Remote ViewLog

With the Remote ViewLog function, you can play back the files recorded at the camera over TCP/IP network.

For first-time users, you need to install the Remote ViewLog program from the Software DVD to the local computer. For remote access to the camera, the **ViewLog Server** built in the unit must be enabled. See *4.3.7 ViewLog Server*.

For details on connecting to the camera for playback, see *5.2.2 Playback over Network*.

4.7 Network

The Network section includes some basic but important network configurations that enable the camera to be connected to a TCP/IP network.

Note: WiFi related settings are only applicable to GV-FE3402 / 3403 / 5302 / 5303 and GV-FER12203, and are only available when a WiFi adapter is inserted to the camera.

4.7.1 LAN

According to your network environment, select among Static IP, DHCP and PPPoE.

LAN Configuration

In this section you can configure GV-IPCAM to work inside of LAN.

Optional Network type

Wired Ethernet Select this option to use wired 10/100Mbps ethernet
 Wireless Select this option to use Wireless

LAN Configuration

Dynamic IP address Select this option to obtain IP address from a DHCP server Test DHCP
 Static IP address Select this option to enter a Static IP address manually

IP Address:
 Subnet Mask:
 Router/Gateway:
 Primary DNS:
 Secondary DNS: (Optional)

PPPoE Select this option to establish a DSL connection

Username:
 Password:

Wireless Settings

Dynamic IP address Select this option to obtain IP address from a DHCP server Test DHCP
 Static IP address Select this option to enter a Static IP address manually

IP Address:
 Subnet Mask:
 Router/Gateway:
 Primary DNS:
 Secondary DNS: (Optional)

Figure 4-24

[Optional Network Type]

According to the network environment, select **Wired Ethernet** or **Wireless**. Before enabling the Wireless option, follow the steps in *2.1.3 Configuring the Wireless Connection* to configure the wireless settings first.

[LAN Configuration]

- **Dynamic IP address:** The network environment has a DHCP server which will automatically assign a dynamic IP address to the camera. Click the **Test DHCP** to see the currently assigned IP address or look up the address using GV-IP Device Utility.
- **Static IP address:** Assign a static IP or fixed IP to the camera. Type the camera's IP address, Subnet Mask, Router/Gateway, Primary DNS server and Secondary DNS server.

Parameters	Default
IP address	192.168.0.10
Subnet Mask	255.255.255.0
Router/Gateway	192.168.0.1
Primary DNS server	192.168.0.1
Secondary DNS server	192.168.0.2

- **PPPoE:** The network environment is xDSL connection. Type the Username and Password provided by ISP to establish the connection. If you use the xDSL connection with dynamic IP addresses, first use the DDNS function to obtain a domain name linking to the camera's changing IP address.

For details on Dynamic DNS Server Settings, see *4.7.2 Advanced TCP/IP*.

4.7.2 Wireless Client Mode

Note this function is only supported in **GV-FE3402 / 3403 / 5302 / 5303** and **GV-FER12203** when GV-WiFi Adapter is installed. Set up the client mode before enabling the wireless function.

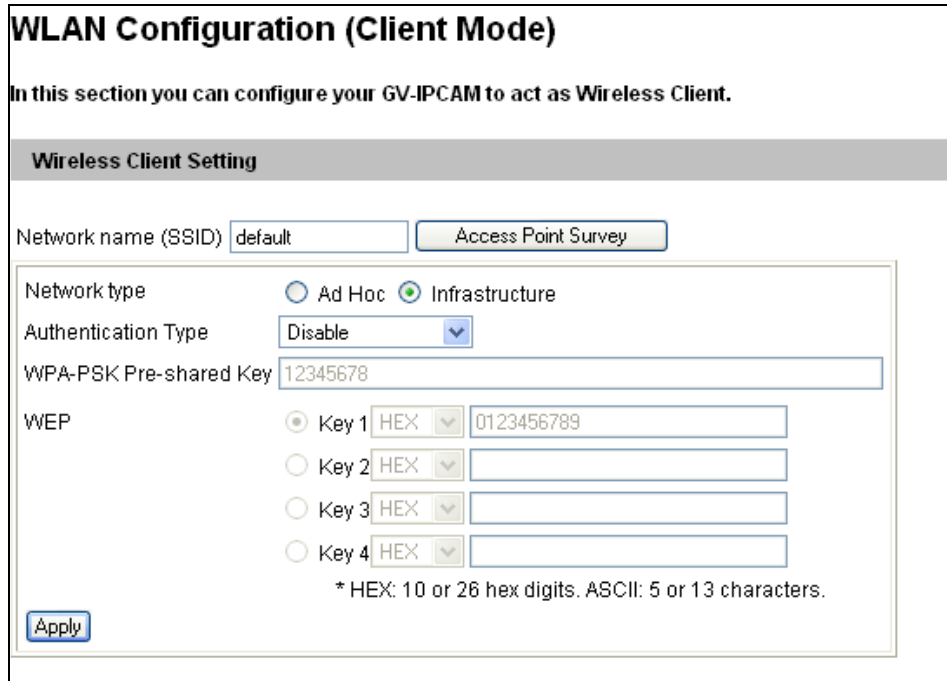

Figure 4-25

- **Network type:** Select the network mode **Ad Hoc** or **Infrastructure**.
 - ⊙ **Infrastructure:** Connect to the Internet via the Access Point. This mode further gives wireless access to the Internet or data sharing under a previously wired environment.
 - ⊙ **Ad-Hoc:** A Peer-to-Peer mode. This mode connects to other computer with the WLAN card, and does not need the Access Point to connect to each other.
- **Network name (SSID):** The SSID (Service Set Identify) is a unique name that identifies a particular wireless network. Type SSID of the Wireless LAN group or Access Point you are going to connect to.
- **Access Point Survey:** Click this button to search all the available Access Points (Infrastructure mode) and wireless stations (AD-Hoc mode) within the LAN.
- **Authentication Type:** Select one of these network authentication and data encryption: **Disable**, **WEP**, **WPAPSK-TKIP**, **WPAPSK-AES**, **WPA2PSK-TKIP** or **WPA2PSK-AES**.
 - ⊙ **Disabled:** No authentication is needed within the wireless network.

- ⊙ **WEP (Wired Equivalent Privacy):** A type of data encryption. Type up to four WEP Keys in HEX or ASCII format. Note that if you use HEX format, only digits 0-9 and letters A-F, a-f are valid.
- ⊙ **WPAPSK-TKIP and WPA2PSK-TKIP:** Type WPA-PSK (Pre-Shared Key) for data encryption.
- ⊙ **WPAPSK-AES and WPA2PSK-AES:** Type WPA-PSK (Pre-Shared Key) for data encryption.

For step-by-step instruction on establishing a wireless connection, see *2.1.3 Configuring the Wireless Connection*.

Note:

1. Your encryption settings must match those used by the Access Points or wireless stations with which you want to associate.
 2. When you lose the wireless access, you can still access the unit by connecting it to a LAN and search for the camera using GV-IP Device Utility.
 3. When **Ad Hoc** is used, only **WEP** encryption is supported.
-

4.7.3 Advanced TCP/IP

This section introduces the advanced TCP/IP settings, including DDNS Server, HTTP port, streaming port, UPnP and QoS.

Advanced TCP/IP

In this section you can set the advanced TCP/IP configuration

Dynamic DNS Server Settings

In this section you can configure your GV-IPCAM to obtain a domain name by using a dynamic IP.

Enable

Service Provider: ex: [Register Geovision DDNS Server](#)

Host Name:

User Name:

Password:

Update Time : [Refresh](#)

HTTP Port Settings

In this section you can change the default HTTP port number (80) to any port within the range 1024-65535. It is a simple method to increase system security using port mapping. You can configure HTTP connection to an alternative port.

HTTP Port:

HTTPS Settings

In this section you can change the default HTTPS port number (443) to any port within the range 1024-65535. It is a simple method to increase system security using port mapping. You can configure HTTPS connection to an alternative port. You can configure HTTPS connection to an alternative port.

Enable

HTTP Port:

External storage is not available. Cannot upload customized certification and private key.

Use customized certification and private key. External storage is necessary.

Certificate File:

Certificate Key File:

Password:

Figure 4-26A

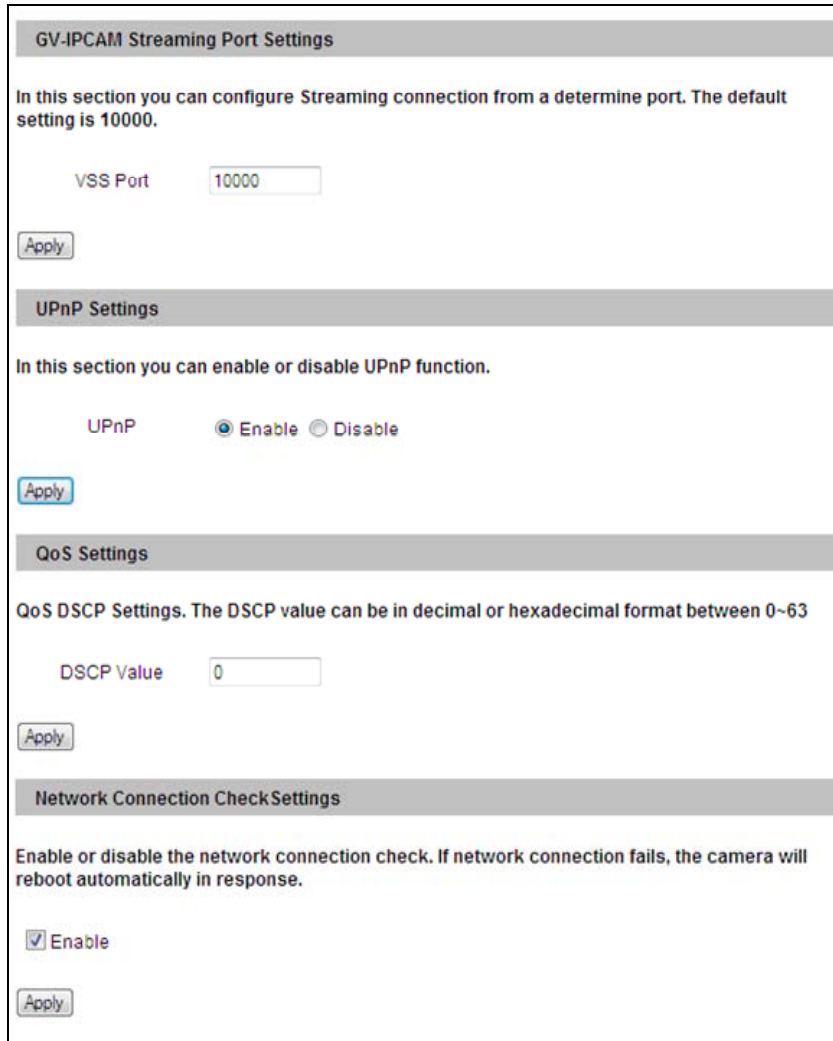

GV-IPCAM Streaming Port Settings

In this section you can configure Streaming connection from a determine port. The default setting is 10000.

VSS Port

UPnP Settings

In this section you can enable or disable UPnP function.

UPnP Enable Disable

QoS Settings

QoS DSCP Settings. The DSCP value can be in decimal or hexadecimal format between 0-63

DSCP Value

Network Connection Check Settings

Enable or disable the network connection check. If network connection fails, the camera will reboot automatically in response.

Enable

Figure 4-26B

[Dynamic DNS Server Settings]

DDNS (Dynamic Domain Name System) provides a convenient way of accessing the camera when using a dynamic IP. DDNS assigns a domain name to the camera, so that the Administrator does not need to go through the trouble of checking if the IP address assigned by DHCP Server or ISP (in xDSL connection) has changed.

Before enabling the following DDNS function, the Administrator should have applied for a Host Name from the DDNS service provider's website. There are 3 providers listed in the camera: GeoVision GVDIP, GeoVision DDNS Server and DynDNS.org.

To enable the DDNS function:

1. **Enable:** Enable the DDNS function.
2. **Service Provider:** Select the DDNS service provider you have registered with.

3. **Host Name:** Type the host name used to link to the camera. For users of GeoVision DDNS Server, it is unnecessary to fill the field because the system will detect the host name automatically.
4. **User Name:** Type the user name used to enable the service from the DDNS. The username should look similar to your host name. Depending on your service provider, you should add a domain name (.dipmap.com, .gvdip.com or .org) after your user name, for example, alice.dipmap.com
5. **Password:** Type the password used to enable the service from the DDNS.
6. Click **Apply**.

[HTTP Port Settings] The HTTP port enables connecting the camera to the web. For security integration, the Administrator can hide the server from the general HTTP port by changing the default HTTP port of 80 to a different port number within the range of 1024 through 65535.

[HTTPS Settings] By enabling the HTTPS settings, you can access the camera through a secure protocol. You can use your own generated Certificate and Private Key or ones verified by the SSL authority. Click **Browse** to locate the Certificate file and Private Key file, and type the password if the .pem files are protected by a password. Click **Apply**. The Web interface will be restarted automatically and you will need to log in again.

Note: Only .pem file format is supported for Certification and Private Key.

[GV-IPCAM Streaming Port Settings] The VSS port enables connecting the camera to the GV-System / GV-VMS. The default setting is 10000.

[UPnP Settings] UPnP (Universal Plug & Play) is a networking architecture that provides compatibility among networking equipment, software and peripherals of the 400+ vendors that are part of the Universal Plug and Play Forum. It means that they are listed in the network devices table for the operating system (such as Windows XP) supported by this function. Enabling this function, you can connect to the camera directly by clicking on the camera listed in the network devices table.

[QoS Settings] The Quality of Service (QoS) is a bandwidth control mechanism that guarantees delay-sensitive data flows such as voice and video streams, obtain a certain amount of bandwidth to keep the streaming smooth.

To apply QoS to the fisheye camera, all network routers must support QoS and QoS must be enabled on these devices. To enable the QoS on the camera, enter a Differentiated Services Code Point (DSCP) value. This value is a field in an IP packet that enables different levels of services for the network traffic. When the video stream from the camera reaches a router, the DSCP value will tell the router what service level to be applied, e.g. the bandwidth amount. This value ranges from 0 to 63 in decimal format. The default value is 0, meaning QoS is disabled.

[Network Connection Check Settings] The camera checks for Internet connection, and reboots when it is disconnected from the Internet. This function is enabled by default.

Note: If you do not intend to connect the camera to the network, disable this function to prevent automatic reboot.

4.7.4 UMTS Settings

UMTS stands for Universal Mobile Telephone System. UMTS is a third-generation (3G) broadband, packet-based transmission of text, digitized voice, video, and multimedia at data rates up to 2 megabits per second. UMTS offers a consistent set of services to mobile computer and phone users, no matter where they are located in the world.

With a mobile broadband device (supporting UMTS, HSDPA, etc.) attached to the USB port on the rear panel, and with this UMTS function enabled, GV-Fisheye Camera can be accessed through wireless broadband. For supported mobile broadband devices, see Appendix C.

The Virtual Private Network (VPN) over a UMTS connection is also configurable on the setting page.

UMTS Settings

In this section you can configure the UMTS settings

UMTS Settings

Set Up UMTS Device

Enable

PIN Number:

Access Point Name (APN):

Username:

Password:

Maximum Transmission Unit:

Retain UMTS connection

Check Interval:

Check VPN Connection

Check Target IP Address:

UMTS Authentication Protocol:

Enable schedule mode:

EnableDNS

Primary DNS:

Secondary DNS: (Optional)

Select schedule time

Span 1 : ~ : Next Day

Span 2 : ~ : Next Day

Span 3 : ~ : Next Day

Weekend Saturday and Sunday Only Sunday

Connection Status

Disconnection

Figure 4-27

- **PIN number:** Type the PIN number that is provided by your network operator.
- **Access Point Name (APN):** Type Access Point Name that is provided by your network operator.
- **Username:** Type a valid username to enable the UMTS service from your network operator.
- **Password:** Type a valid password to enable the UMTS service from your network operator.
- **Maximum Transmission Unit:** Type the Maximum Transfer Unit (MTU). The default value is **1500**.
- **Retain UMTS Connection:** Select this option to check the UMTS connection status and use the drop-down list to specify the desired time length for check frequency. The GV-Video Server will rebuild the connection if disconnection is detected.
- **Enable VPN Connection:** Select this option to enable the VPN (Virtual Private Network) connection. Type the target IP address in the **Check Target IP Address** field.
- **UMTS Authentication Protocol:** Use the drop-down list to select the UMTS Authentication Protocol provided by your network operator.
- **Enable Schedule Mode:** Starts the UMTS connection automatically based on the schedule you set in the **Select Schedule Time** section. Refer to *4.5 Recording Schedule* for the same settings.
- **Enable DNS:** Optional type up to two DNS servers of your network operator.
- **3G Connection Status:** Indicates the connection status of UMTS or VPN.

Note: When both WiFi and 3G signals are detected, the camera will connect to the network through WiFi.

4.7.5 IP Filtering

The Administrator can set IP filtering to restrict access to the camera.

IP Filter Setting

In this section you can allow or deny network connection listed in the table. (Filter Table support only 4 entries.)

IP Filtering

Enable IP Filtering

No.	IP Address Range in CIDR format	Action	Customize
1	192.168.0.66	Allow	<input type="button" value="Remove"/>

Filtered IP: ex: 192.168.1.2 or 192.168.1.0/24

Action to take:

Figure 4-28

To enable the IP Filter function:

1. **Enable IP Filtering:** Enable the IP Filtering function.
2. **Filtered IP:** Type the IP address you want to restrict the access.
3. **Action to take:** Select to **Allow** or **Deny** the IP address(es) you have specified.
4. Click **Apply**.

4.7.6 SNMP Setting

The Simple Network Management Protocol (SNMP) allows you to monitor the status of the camera with SNMP network management software.

SNMP Settings

In this section you can configure the SNMP settings.

SNMP Configuration

Enable SNMPv1, SNMPv2

Read/Write Name

Read Only Name

Enable SNMPv3

Read/Write Name

Authentication Type

Authentication Password

Current password (Encrypted)

Read Only Name

Authentication Type

Authentication Password

Current password (Encrypted)

Figure 4-29

To set up the SNMP settings:

1. Select **Enable SNMPv1 SNMPv2c** to enable the function.
2. To enable access to **Read/Write Name**, type a community string. This will serve as a password to allow read and write access to the camera from the SNMP software.
3. To enable **Read Only Name**, type a community string to allow read only access to the camera from the SNMP software.
4. For a more secured connection, select **Enable SNMPv3** to enable SNMP version 3.
5. To enable access to SNMPv3 Read/Write community, type a **Read/Write Name**.
6. Select an **Authentication Type** to use for SNMP requests.
7. Type the **Authentication Password** and **Current Password (Encrypted)**. You will need to type these passwords in the SNMP software to be able to access the camera.
8. To enable access to SNMPv3 Read only community, type a **Read Only Name** and follow steps 6 – 7.
9. Click **Apply** to save the settings.

4.8 Management

The Management section includes the settings of data and time and user account. Also you can view the firmware version and execute certain system operations.

4.8.1 Date and Time Settings

The date and time settings are used for date and time stamps on the image.

Date and Time Settings

In this section you can configure time and date or just synchronize with a NTP server.

Date and Time on IPCAM

Sun Apr 15 12:47:06 2001

Time Zone

(GMT+08:00) China,Hong Kong,Australia Western,Singapore,Taiwan,Russia ▼

Enable Daylight Saving Time

Start (MM/dd/hh/mm)

End (MM/dd/hh/mm)

Synchronized with a Network Time Server

Synchronized with Network Time Server (NTP)

Host name or IP Address:

Update period: 24 hours; Update Time: AM 05:10 :

Synchronized with your computer or modify manually

Modify manually

Date (yyyy/mm/dd)

Time (hh:mm:ss)

Synchronized with your computer

Date and time overlay setting

Show date as ▼

(This is a format of date where yyyy stands for year in 4 digits or yy in 2 digits, mm stands for month, and dd stands for day)

Display order

Date prior to time (Ex.2007/05/21 17:00:00)

Time prior to date(Ex.17:00:00 2007/05/21)

Figure 4-30

[Date & Time on IPCAM] Displays the current date and time on the camera.

[Time Zone] Sets the time zone for local settings. Select **Enable Daylight Saving Time** to automatically adjust the camera for daylight saving time. Type the Start Time and End Time to enable the daylight saving function. To playback, see *5.2.4 Playback of Daylight Saving Time Events*. To automatically synchronize the Daylight Saving Time with the GV-System, see *7.1.1 Customizing the Basic Settings*.

For **GV-FER12203** firmware V1.02 or later, you can also select which day of a week within a month to apply the DST setting.

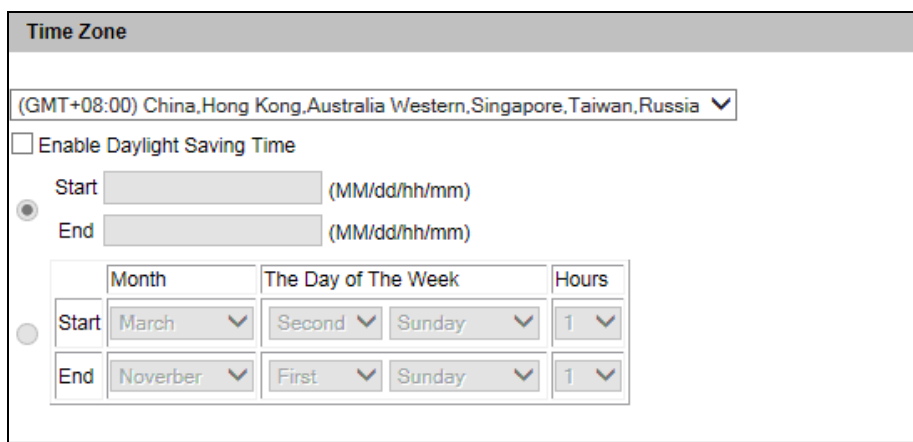

[Synchronized with a Time Server] By default, the camera uses the timeserver of time.windows.com to automatically update its internal clock every 24 hours at the Update Time you specified. You can also change the host name or IP setting to the timeserver of interest.

[Synchronized with your computer or manually] Manually changes the camera's date and time. Or, synchronize the camera's date and time with those of the local computer.

[Date and time overlay setting] Select the display format of date and time stamps on the image. For this function to work, you must also enable the **Overlaid with date stamps** and **Overlaid with time stamps** options in Figure 4-2.

4.8.2 Storage Settings

Based on Linux ext3 file system, the camera supports memory cards for video and audio recordings. You need to format the memory card by using the following Storage Settings. After being formatted, the memory card will be ready to use by Linux OS of the camera.

Storage Settings

In this section you can configure the disk storage to archive videos and events.

The recording data may be lost if the power supply is interrupted during recording.

Storage Settings

Name

Enable recycling
 Stop recording or recycle disk when free space of disk is smaller than

Keep days (1-255)

Record Disk Type

Enable debug message to the storage.

Enable auto formatting when disk or partition is unable to record.

Network Neighborhood Settings

Server URL/IP Address User Name Password

Enable

Disk Information

Disk No.	Total Size	Used Size	Free space	Utilization	Remove	Format
Disk0	1862.852	2.841	1860.010	0%	<input type="button" value="Remove"/>	<input type="button" value="Format"/>

Partition Information

Disk No.	Partition No.	Total Size	Used Size	Free space	Utilization	Status	Other
Disk0	10	195.298	0.196	195.102	0%	OK	<input type="button" value="Format"/>
Disk0	11	195.298	0.183	195.115	0%	OK	<input type="button" value="Format"/>
Disk0	12	195.298	0.183	195.115	0%	OK	<input type="button" value="Format"/>
Disk0	13	195.298	0.183	195.115	0%	OK	<input type="button" value="Format"/>
Disk0	14	105.148	0.183	104.965	0%	OK	<input type="button" value="Format"/>
Disk0	5	195.298	1.160	194.137	0%	OK	<input type="button" value="Format"/>
Disk0	6	195.298	0.182	195.115	0%	OK	<input type="button" value="Format"/>
Disk0	7	195.298	0.183	195.115	0%	OK	<input type="button" value="Format"/>
Disk0	8	195.298	0.183	195.115	0%	OK	<input type="button" value="Format"/>
Disk0	9	195.298	0.183	195.115	0%	OK	<input type="button" value="Format"/>

Network Neighborhood Disk Information

Disk No.	Total Size	Used Size	Free space	Utilization
No HDD connected				

(Unit: Gigabyte)

Figure 4-31

[Storage Settings]

- **Enable recycling:** If the **Enable recycling** option is selected, when the space of the storage device is lower than the specified space, the system will either write the data to another device or overwrite the oldest recorded files. If the **Enable recycling** option is not selected, the system will stop recording when the specified space is reached.
- **Keep days (1-255):** Specify the number of days to keep the files from 1 day to 255 days. When both **Keep days** and **Enable recycling** are selected, the system applies whichever condition comes first. For example, if the specified smallest amount of storage space comes earlier than the designated keep days, then recycle is applied first.
- **Enable debug message to the storage:** Debug message (see *4.8.4 Log Information*) is deleted after reboot. Select this option to store log information to the attached storage device.
- **Enable auto formatting when disk or partition is enable to record:** Select this option for the camera to automatically format the storage device when there is error during recording.

[Network Neighborhood Settings]

You can record your GV-Fisheye Camera to a connected NAS server.

Note:

1. GV-FER12203 does not support connection with NAS servers.
2. Make sure your camera's video settings adhere to the following:
 - VBR is set to **Good**
 - Maximal Bit Rate is set to the following:

Camera Type	Max. Bit Rate
1.3 MP	6 Mbit or lower
2 MP / 3 MP / 4 MP / 5 MP	8 Mbit or lower

3. For optimal performance and compatibility, it is highly recommended to use a GV-NAS System.
 4. It is highly recommended that the NAS server supports quota function, and a separate quota is allocated to each camera.
 5. This NAS recording function is only supported for GV-IP Camera (firmware V3.0 or later).
 6. GV-IP Camera does not support recording to shared folders of a Windows-based server.
-

To record to GV-NAS Systems, follow the steps below.

1. Under Network Neighborhood Settings, select **Enable** and click the **Search** button to search for available NAS servers.

Figure 4-32

2. Type the username and password, and click **Select**.

Samba Domain List				
Group	Domain	Username	Password	Selection
WORKGROUP	GV-NAS2008	Cam01	*****	Select

Figure 4-33

Note: Depending on the models of GV-NAS System, up to 16 default user accounts (username: **Cam01 – Cam16**; password: **12345678**) are available. The storage limitation and recycle is applied on a user basis. It is recommended to use one user account exclusively for recording of one GV-IP Camera to avoid uneven data recycle.

3. Select a folder to store recordings, and click **OK**.

Folder List		
FolderName	Type	Selection
IP_Camera	Disk	<input checked="" type="radio"/>
md1-public	Disk	<input type="radio"/>
Cam01	Disk	<input type="radio"/>

ok

Figure 4-34

4. Click **Apply**. Once connected, the disk status will display.

Disk Status				
Network Neighborhood Disk Information				
Disk No.	Total Size	Used Size	Free space	Utilization
//192.168.0.1/IP_Camera	50.000	49.570	0.429	99%

(Unit: Gigabyte)

Figure 4-35

Tip: Instead of searching for available NAS servers, you can also type the storage path directly.

1. Type the Server URL/ IP Address in this format: **\\NAS IP Address\Storage Folder**. For example, **\\192.168.0.1\IP_Camera**. This GV-IP Camera will be recorded to a default shared folder named “IP_Camera” in the GV-NAS System.
2. Type the username and password. For GV-NAS System, you can type any of default usernames **Can01** to **Cam16**, and password is **12345678**.

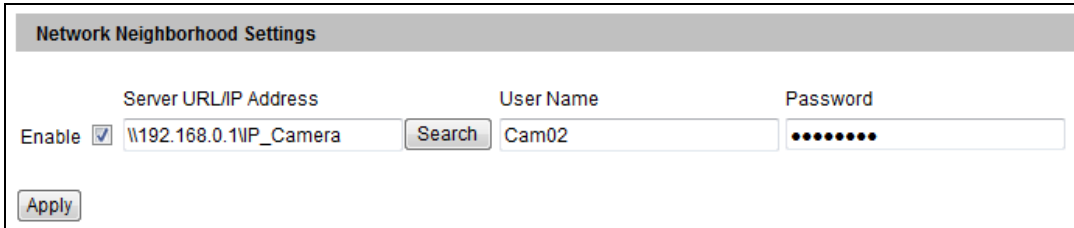

The screenshot shows a web interface titled "Network Neighborhood Settings". It contains three input fields: "Server URL/IP Address" with the value "\\192.168.0.1\IP_Camera", "User Name" with the value "Cam02", and "Password" with a masked password of eight dots. There is an "Enable" checkbox that is checked, a "Search" button next to the first field, and an "Apply" button at the bottom left.

For details on GV-NAS System, refer to *GV-NAS System Quick Start Guide*.

[Disk Information]

This section shows the details of the attached storage devices. Use the **Format** or **Remove** button to format or unload a storage device. For detail steps, see *Partition Information* below.

[Partition Information]

This section shows the partition details of the attached storage devices.

To add a memory card:

1. Insert the memory card to the camera.
2. Click the **Format** button.
3. After the format is complete, the partition information will display. The maximum space for one partition is 200 GB.

To remove a memory card:

1. Click the **Remove** button.
2. When you are prompted to confirm the action, click **Yes**. The page will be refreshed and the partition information will be cleaned.
3. Remove the memory card from the camera.

The storage device status is indicated in the status column:

Status	Description
Formatting	The storage device is being formatted.
Unknown	The camera cannot recognize the format of the storage device or the device cannot be found.
OK	Storage formatting is successful.
Try Mount	The camera is attempting to connect to the storage device.
Error File System	There is a recording error in the storage device. All the recording data is inaccessible under this status.
Read Only	The storage device cannot be written to due to abnormal power disruption.
Repairing	The system is attempting to repair the recording data.

Note:

1. If **Enable Recycle** is selected, the available space of the storage device must be higher than the space you specified at the **Stop recording or recycle disk when free space of disk is smaller than x** option. Otherwise no video will be recorded.
2. The recording data may be lost if you remove the storage device during recording.
3. If you do not remove the storage device properly, the data cannot be read in another computer. In this case, re-plug the storage device back to the camera. The system will repair the data automatically. When the system is repairing the data, the **Remove** field will display "Repairing".
4. To upgrade the firmware from versions earlier than V2.07 to the latest version, be sure to back up the recordings on the camera's memory card first before the upgrade, and re-format the memory card after the upgrade. If you have not done so, this warning message appears when you view the Monitoring or Storage Settings' Web interface:

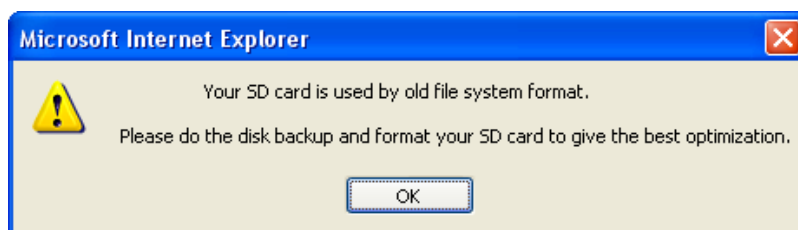

Figure 4-36

4.8.3 User Account

You can change the login name and password of Administrator, Guest and FTP Server User.

- The default Administrator login name and password are **admin**.
- The default Guest login name and password are **guest**. To allow a Guest user to log in without entering name and password, select **Disable authentication for guest account**.
- The default FTP Server login name is **ftpuser** and default password is **123456**.

User Account

In this section you can change the administrator account and password

Administrator Account

Username:

Old Password:

New Password:

Confirm Password:

Guest User Account

Username:

Old Password:

New Password:

Confirm Password:

Disable authentication for guest account

FTP Server User Account

Username:

Old Password:

New Password:

Confirm Password:

Figure 4-37

4.8.4 Log Information

The log information contains dump data that is used by service personnel for analyzing problems.

Log Information

In this section you can see all system activities.

Startup time log

In this section you can see latest booting time of system.

Debug Messages

This section shows the data used for debugging.

```
Nov 12 18:09:01 Video Server[1072]: (1177) connect_video_gateway[230]: Video-Gateway thread: connect() failed
Nov 12 18:09:04 Video Server[1072]: (1177) connect_video_gateway[230]: Video-Gateway thread: connect() failed
Nov 12 18:09:04 Video Server[1072]: (1177) videogateway_connect_all[315]: Video Gateway thread: try original IP:
[192.168.4.43]:50000
Nov 12 18:09:04 Video Server[1072]: (1177) video_gateway_server_thread[836]: Quitting to connect VIDEO_GATEWAY, wait to
retry
Nov 12 18:09:11 Video Server[1072]: (1177) connect_video_gateway[230]: Video-Gateway thread: connect() failed
Nov 12 18:09:14 Video Server[1072]: (1177) connect_video_gateway[230]: Video-Gateway thread: connect() failed
Nov 12 18:09:14 Video Server[1072]: (1177) videogateway_connect_all[334]: Video Gateway thread: try last connected IP:
[192.168.4.43]:50000
Nov 12 18:09:17 Video Server[1072]: (1177) connect_video_gateway[230]: Video-Gateway thread: connect() failed
Nov 12 18:09:20 Video Server[1072]: (1177) connect_video_gateway[230]: Video-Gateway thread: connect() failed
Nov 12 18:09:20 Video Server[1072]: (1177) videogateway_connect_all[315]: Video Gateway thread: try original IP:
[192.168.4.43]:50000
Nov 12 18:09:20 Video Server[1072]: (1177) video_gateway_server_thread[836]: Quitting to connect VIDEO_GATEWAY, wait to
retry
Nov 12 18:09:27 Video Server[1072]: (1177) connect_video_gateway[230]: Video-Gateway thread: connect() failed
Nov 12 18:09:30 Video Server[1072]: (1177) connect_video_gateway[230]: Video-Gateway thread: connect() failed
Nov 12 18:09:30 Video Server[1072]: (1177) videogateway_connect_all[334]: Video Gateway thread: try last connected IP:
[192.168.4.43]:50000
Nov 12 18:09:33 Video Server[1072]: (1177) connect_video_gateway[230]: Video-Gateway thread: connect() failed
Nov 12 18:09:36 Video Server[1072]: (1177) connect_video_gateway[230]: Video-Gateway thread: connect() failed
Nov 12 18:09:36 Video Server[1072]: (1177) videogateway_connect_all[315]: Video Gateway thread: try original IP:
[192.168.4.43]:50000
```

System Message

This section shows the data used for debugging.

```
ytesGenerated=0 or No Cap or Enc Buffer to Use
[01140] (11/12/13 10:42:11 2013 GMT8:00): Encoder Stream (1): Frame Skip because: bytesGenerated=0 or No Cap or Enc Buffer
to Use
[01140] (11/12/13 10:42:11 2013 GMT8:00): Encoder Stream (1): Frame Skip because: bytesGenerated=0 or No Cap or Enc Buffer
to Use
[01140] (11/12/13 10:42:11 2013 GMT8:00): Encoder Stream (1): Frame Skip because: bytesGenerated=0 or No Cap or Enc Buffer
to Use
[01140] (11/12/13 10:42:11 2013 GMT8:00): Encoder Stream (1): Frame Skip because: bytesGenerated=0 or No Cap or Enc Buffer
to Use
[01140] (11/12/13 10:42:11 2013 GMT8:00): Encoder Stream (1): Frame Skip because: bytesGenerated=0 or No Cap or Enc Buffer
to Use
[01140] (11/12/13 10:42:12 2013 GMT8:00): Encoder Stream (1): Frame Skip because: bytesGenerated=0 or No Cap or Enc Buffer
to Use
[01140] (11/12/13 10:42:12 2013 GMT8:00): Encoder Stream (1): Frame Skip because: bytesGenerated=0 or No Cap or Enc Buffer
to Use
[01140] (11/12/13 10:42:12 2013 GMT8:00): Encoder Stream (1): Frame Skip because: bytesGenerated=U or No Cap or Enc Buffer
to Use
[01140] (11/12/13 10:42:12 2013 GMT8:00): Encoder Stream (1): Frame Skip because: bytesGenerated=0 or No Cap or Enc Buffer
to Use
[01140] (11/12/13 10:42:12 2013 GMT8:00): Encoder Stream (1): Frame Skip because: bytesGenerated=0 or No Cap or Enc Buffer
to Use
[01140] (11/12/13 10:42:12 2013 GMT8:00): Encoder Stream (1): Frame Skip because: bytesGenerated=0 or No Cap or Enc Buffer
to Use
[01140] (11/12/13 10:42:12 2013 GMT8:00): Encoder Stream (1): Frame Skip because: bytesGenerated=0 or No Cap or Enc Buffer
to Use
```

Figure 4-38-1

```

Notice Message

This section shows the data used for debugging.

Start[0], Count[143], data_count[1023]
(00001) Time (01/04/00 18:17:58 2000 GMT8:00) - Firmware Info - Build Time : Mon Oct 7 13:00:44 CST 2013
(00002) Time (01/04/00 18:18:00 2000 GMT8:00) - IPCAM Version: HW(0x2, 0x7) HID(0)
(00003) Time (01/04/00 18:18:17 2000 GMT8:00) - (GV-BX3400) ssvr start up
(00004) Time (01/04/00 18:48:44 2000 GMT8:00) - IPCAM System Starting
(00005) Time (01/04/00 18:48:45 2000 GMT8:00) - Firmware Info - Firmware for Nand 128M
(00006) Time (01/04/00 18:48:45 2000 GMT8:00) - Firmware Info - Build Time : Mon Oct 7 13:00:44 CST 2013
(00007) Time (01/04/00 18:48:47 2000 GMT8:00) - IPCAM Version: HW(0x2, 0x7) HID(0)
(00008) Time (01/04/00 18:49:02 2000 GMT8:00) - (GV-BX3400) ssvr start up
(00009) Time (01/04/00 19:19:29 2000 GMT8:00) - IPCAM System Starting
(00010) Time (01/04/00 19:19:30 2000 GMT8:00) - Firmware Info - Firmware for Nand 128M
(00011) Time (01/04/00 19:19:30 2000 GMT8:00) - Firmware Info - Build Time : Mon Oct 7 13:00:44 CST 2013
(00012) Time (01/04/00 19:19:32 2000 GMT8:00) - IPCAM Version: HW(0x2, 0x7) HID(0)
(00013) Time (01/04/00 19:19:48 2000 GMT8:00) - (GV-BX3400) ssvr start up
(00014) Time (01/04/00 19:50:15 2000 GMT8:00) - IPCAM System Starting
(00015) Time (01/04/00 19:50:16 2000 GMT8:00) - Firmware Info - Firmware for Nand 128M
(00016) Time (01/04/00 19:50:16 2000 GMT8:00) - Firmware Info - Build Time : Mon Oct 7 13:00:44 CST 2013
(00017) Time (01/04/00 19:50:18 2000 GMT8:00) - IPCAM Version: HW(0x2, 0x7) HID(0)
(00018) Time (01/04/00 19:50:34 2000 GMT8:00) - (GV-BX3400) ssvr start up
(00019) Time (01/04/00 20:21:02 2000 GMT8:00) - IPCAM System Starting
(00020) Time (01/04/00 20:21:03 2000 GMT8:00) - Firmware Info - Firmware for Nand 128M
(00021) Time (01/04/00 20:21:03 2000 GMT8:00) - Firmware Info - Build Time : Mon Oct 7 13:00:44 CST 2013
(00022) Time (01/04/00 20:21:05 2000 GMT8:00) - IPCAM Version: HW(0x2, 0x7) HID(0)
(00023) Time (01/04/00 20:21:22 2000 GMT8:00) - (GV-BX3400) ssvr start up

```

Figure 4-38-2

4.8.5 Tools

This section allows you to execute certain system operations and view the firmware version.

Additional Tools

In this section you can set the additional tools

Host Settings

In this section you can determine a hostname and camera name for identification.

Host Name

Auto Reboot Setup

In this section you can set the system's auto reboot time.

Enable

Day Interval days

RebootTime :

Repair Recording Database

Click Apply to repair the database when you cannot play back recordings.

Repairing Status

Unknown

Firmware Update

In this section you can see GV-IPCAM firmware version.

System Settings

Restore to factory default settings

Restore to factory default settings(Except network)

Internal Temperature

Internal Temperature Normal Range: 0°C ~ 95°C (32°F ~ 203°F)

Current chipset temperature inside camera is °C/ °F

Reboot

Do you wish to reboot now?

Figure 4-39

[Host Name] Type a descriptive name for the camera.

[Auto Reboot Setup] Select **Enable** to activate automatic reboot and specify the time for reboot in the sub fields.

- **Day Interval:** Type the day interval between each automatic reboot.
- **Reboot Time:** Use the drop-down lists to specify the time for automatic reboot.

[Repair Record Database] Click **Apply** to repair the database when errors occur while playing back the recordings with Remote ViewLog player. Errors can occur when there are errors in firmware or damages to the micro SD card.

[Database Status] Displays the status of the repairing database.

[Firmware Update] This field displays the firmware version of the camera.

[System Settings] Clicking the **Load Default** button will restore the camera to factory default settings. You can choose to include or exclude network settings when loading factory default settings.

Note: After applying the default function, you will need to configure the camera's network setting again.

[Temperature Status] Displays the chipset temperature inside the camera. You can also see the **Current chipset temperature inside the camera**.

[Reboot] Clicking the **Reboot** button will make the camera perform software reset.

4.8.6 Language

This section allows you to select the language of the Web interface. The Default option sets the Web interface to the language of the computer's operating system.

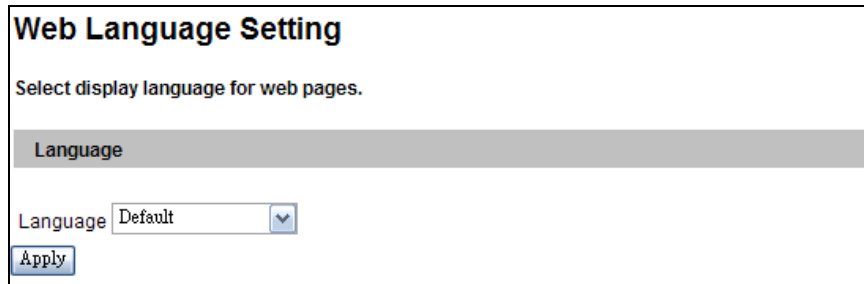

The screenshot shows a web interface titled "Web Language Setting". Below the title is the instruction "Select display language for web pages." There is a section header "Language" in a grey bar. Below this, the label "Language" is followed by a dropdown menu currently set to "Default". At the bottom left of the form is an "Apply" button.

Figure 4-40

Chapter 5 Recording and Playback

The camera can record video and audio directly to the memory card. You can play back the recorded files on the GV-System / GV-VMS or over the TCP/IP network.

Note: See *Note for Recording* at the beginning of the manual.

5.1 Recording

To enable the recording function:

1. Insert the memory card to the camera. See “To add a memory card,” *4.8.3 Storage Settings*.
2. If you want to set up pre-recording, post-recording or audio recording, see *4.1.1 Video Settings*.
3. If you want to set up the schedule for video recording or I/O monitoring, see *4.5 Recording Schedule*.
4. If you want to configure the areas and sensitivity values for motion detection, see *4.1.2 Motion Detection*.
5. If you want the recording to be triggered by input device, configure the operation of I/O devices. See *4.2.1 Input Settings*.
6. To start recording and I/O monitoring, see *4.4 Monitoring*.

The camera will start recording upon motion detection, I/O trigger, or during the scheduled time.

5.2 Playback

These methods are available to play back the video files recorded at the camera:

- Playback from the memory card by connecting it directly to the GV-System / GV-VMS through a card reader
- Playback using the Remote ViewLog function over the TCP/IP network
- Playback using the recorded files downloaded from built-in FTP Server

5.2.1 Playback from the Memory Card

You can play back the files recorded at the camera by attaching the memory card to the GV-System / GV-VMS. However, the videos on the camera are recorded in the Linux format and GV-System / GV-VMS runs on a Windows-based computer. For Linux files to be readable and accessible on Windows, we use the Ext2Fsd program. Follow the steps below to download, install and execute the Ext2Fsd program.

IMPORTANT:

1. Due to the compatibility issue, the Ext2Fsd program is required for GV-IP Camera firmware V2.07 or later.
 2. The Ext2Fsd program only works on Windows 2000, XP, 2003, vista, 7, 8 and Server 2012 (32-bit and 64-bit).
 3. The Ext2Fsd program is subject and under term/condition of The GNU General Public License version 2 (GPLv2). Please read <http://www.gnu.org/licenses/gpl-2.0.html> before installation.
-

1. Install the Ext2Fsd from the Software DVD.

Note: If you are using **Windows 8** or **Windows Server 2012**, change its compatibility before installing the Ext2Fsd program:

A. Right-click the Ext2Fsd program and select **Properties**. This dialog box appears.

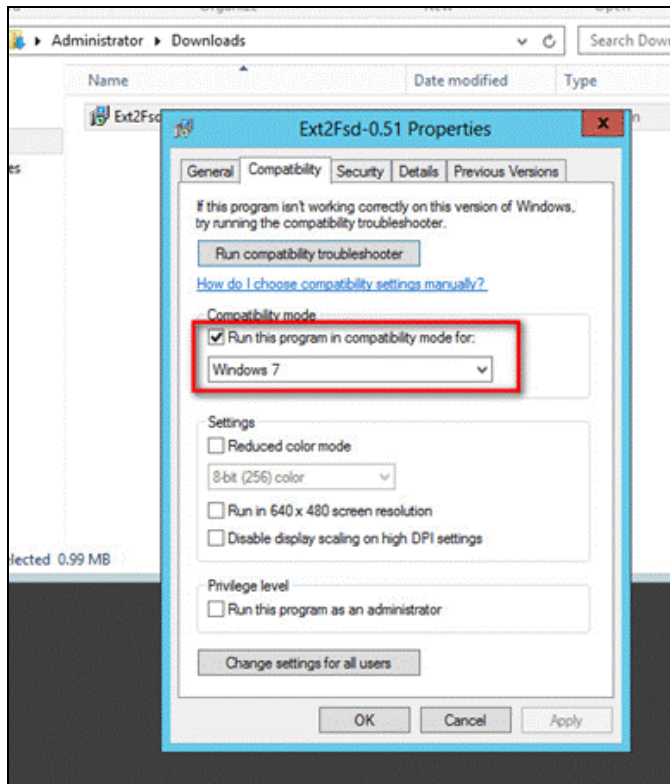

Figure 5-1

B. Select the **Compatibility** tab.

C. Select **Windows 7** using the drop-down list.

2. On Your desktop, click **Start**, select **Programs**, locate the **Ext2Fsd** folder and select **Ext2 Volume Manager**. All the connected drives are shown.

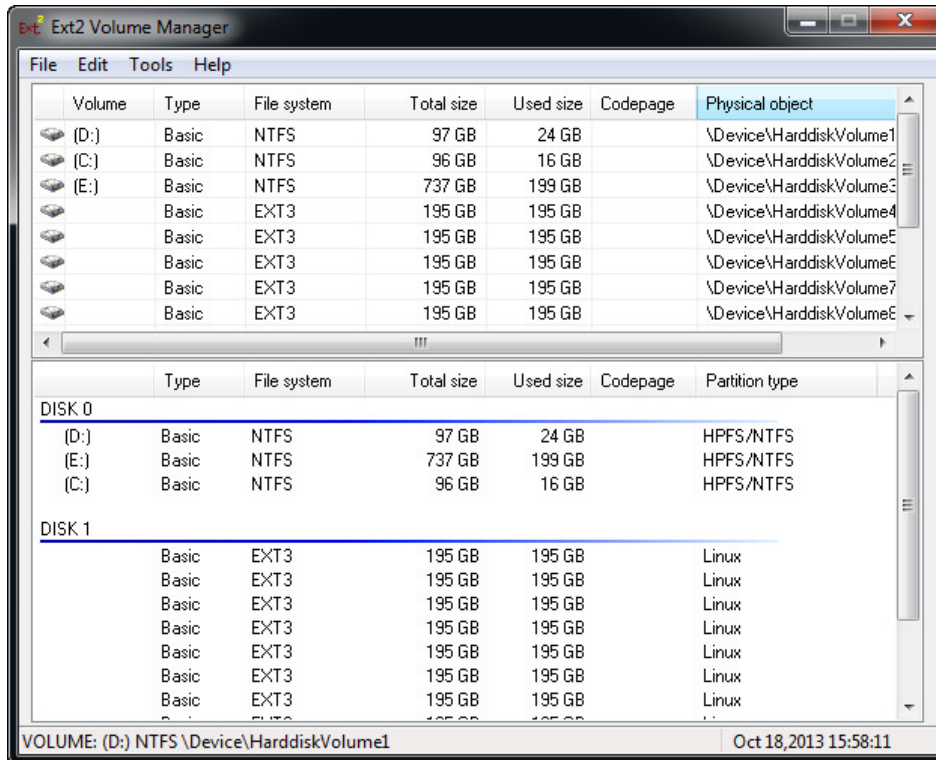

Figure 5-2

3. For the first-installation, execute the Ext2Fsd Service.
 - A. From the Ext2 Volume Manager window, select **Tools** and select **Service Management**. This dialog box appears.

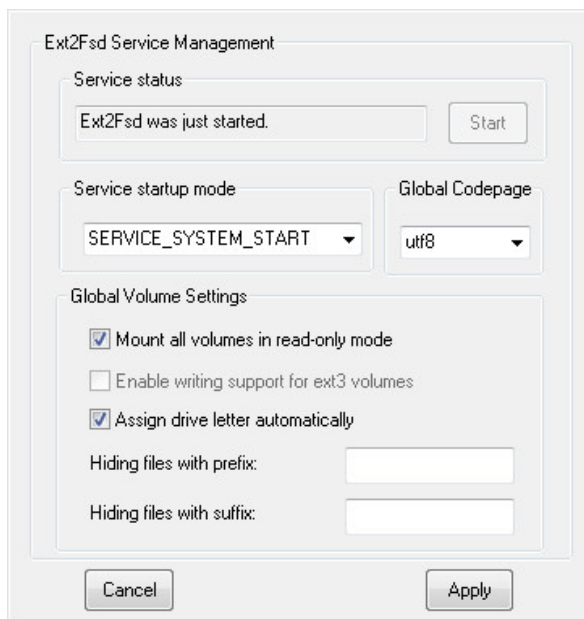

Figure 5-3

- B. Click **Apply**.

4. Mount the storage drive to your computer.
 - A. From the Ext2Fsd Volume Manager window, right-click the storage drive and select **Ext2 Management**. This dialog box appears.

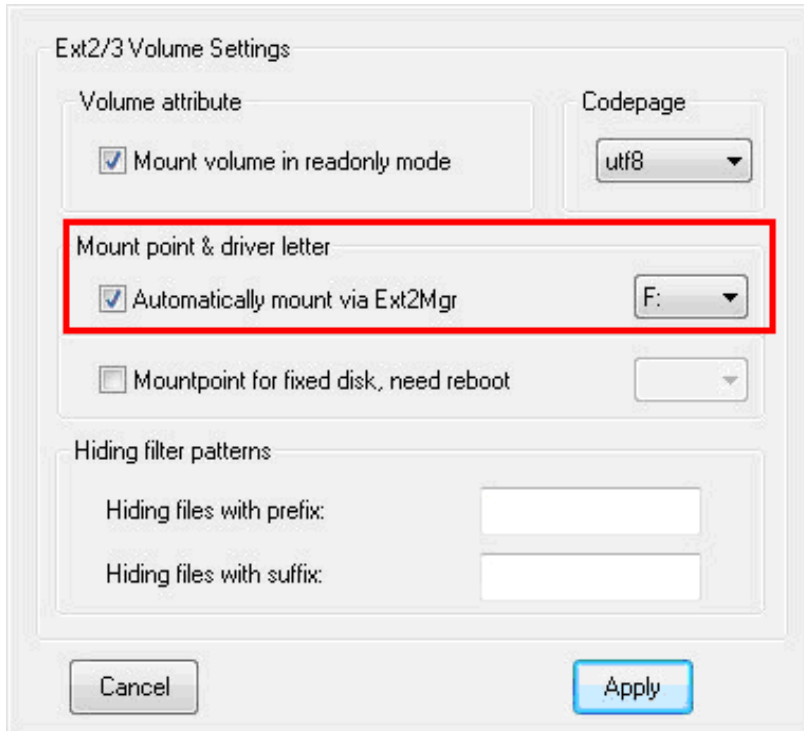

Figure 5-4

- B. Under the Mount point & driver letter section, select **Automatically mount via Ext2Mgr**, specify a disk drive using the drop-down list and click **Apply**.

C. On the Ext2 Volume Manager window, the storage drive is successfully mounted to your computer when it is indicated with the disk drive you specified.

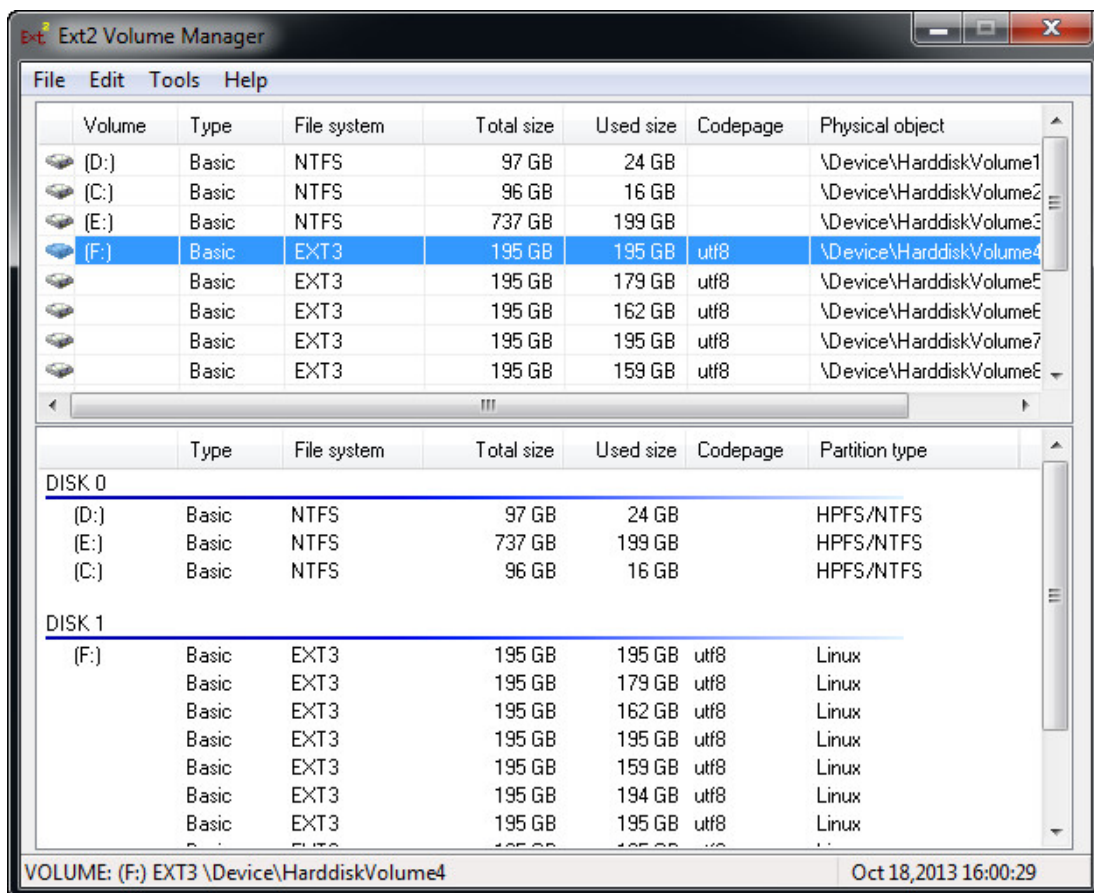

Figure 5-5

5. Access the recording files from the specified drive of your computer.

5.2.2 Playback over Network

With the Remote ViewLog function, you can play back the files recorded at the camera over TCP/IP network.

1. The camera must allow remote access with **ViewLog Server** activated. See 4.3.7 *ViewLog Server*.
2. For first time users, run the **Remote ViewLog** program from the Software DVD. Next time whenever you would like to use this function, access this option from the camera's Web interface.
3. When this dialog box appears, type the camera's IP address, login ID and password. Keep the default port **5552** or modify it if necessary.

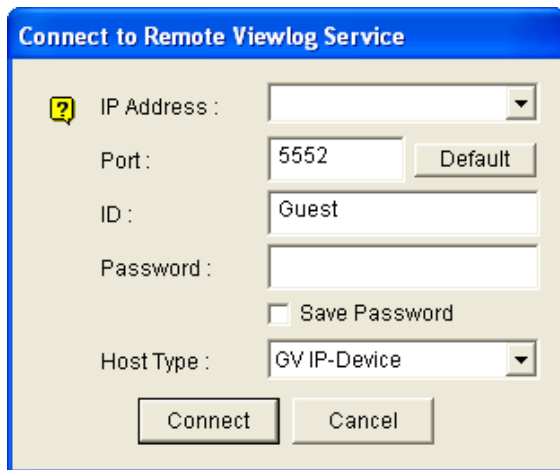

Figure 5-6

3. In the **Host Type** field, select **GV IP-Device**.
4. Click **Connect** to access the files of the camera for playback.

5.2.3 Access to the Recorded Files through FTP Server

The built-in FTP Server allows you to download the recorded files saved on the memory card. You can play back the downloaded files of AVI format with any multimedia player. For details to download files, see [Act as FTP Server], 4.3.2 *FTP*.

Note: To play back videos, ensure you have installed Geovision codec on the computer. The codec is available on the software DVD. If you have installed the Remote Playback player on the computer, it is not required to install the codec.

5.2.4 Playback of Daylight Saving Time Events

On GV-System, you can retrieve the events recorded during the Daylight Saving Time (DST) period from the camera for playback. You can also connect the memory card with the recorded files to GV-System for playback.

The following instructions describe how to retrieve the recorded files from the camera over Internet. If you like to use the memory card for playback, first follow the instructions in 5.2.1 *Playback Using the Memory Card* to load the recorded files to ViewLog, and then follow Steps 4-5 below to play back DST events.

1. The camera must allow the remote access with **ViewLog Server** activated. See 4.3.7 *ViewLog Server*.
2. To remotely connect to the camera from GV-System, click the **Tools** button and select **Remote ViewLog Service**. The Connect to Remote ViewLog Service dialog box appears.
3. Enter the connection information of the camera, and click **Connect**. Once the connection is established, the video events will be displayed on the Video Event list.
4. On the Date Tree, select the date of Daylight Saving Time. A separate DST subfolder will be displayed as illustrated below.

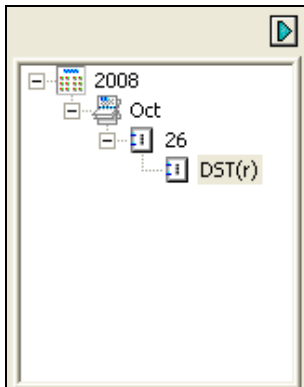

Figure 5-7

5. On the Video Event list, select desired events, and click the **Play** button to start.

Note:

1. The playback function is only compatible with GV-System version 8.4 or later.
 2. The AVI file recorded during the DST period is named with the prefix “GvDST”, e.g. GvDST20081022xxxxxxxxx.avi, to differentiate from the regular AVI file named with the prefix “Event”, e.g. Event20081022xxxxxxxxx.avi.
-

Chapter 6 Advanced Applications

This chapter introduces more advanced applications.

6.1 Upgrading System Firmware

GeoVision periodically releases the updated firmware on the website. The new firmware can be simply loaded into the camera using the Web interface or the **IP Device Utility** included on the Software DVD.

Important Notes before You Start

Before you start updating the firmware, please read these important notes:

1. To update the camera firmware to V2.07, **back up the files in the storage device to another storage first** before the upgrade.
2. If you use the IP Device Utility for firmware upgrade, the computer used to upgrade firmware must be under the same network of the camera.
3. Stop monitoring of the camera.
4. Stop all the remote connections including Center V2, Vital Sign Monitor, ViewLog Server and RTSP.
5. Stop the connection to GV-System.
6. While the firmware is being updated,
 - A. the power supply must not be interrupted, and
 - B. do not unplug the Ethernet cable if the cable is the source of power supply (Power over Ethernet or PoE supported).

WARNING: The interruption of power supply during updating causes not only update failures but also damages to your camera. In this case, please contact your sales representative and send your device back to GeoVision for repair.

7. Do not turn the power off within 10 minutes after the firmware is updated.
8. If firmware upgrade fails, you will need to restore the camera to the default settings. For details, see *6.3 Restoring to Factory Default Settings* in the User's Manual.

9. Since the firmware adopts different storage format from V2.07 onward, be sure to re-format the memory card after firmware upgrade. If you have not done so, this warning message appears when you view the Monitoring or Storage Settings' Web interface:

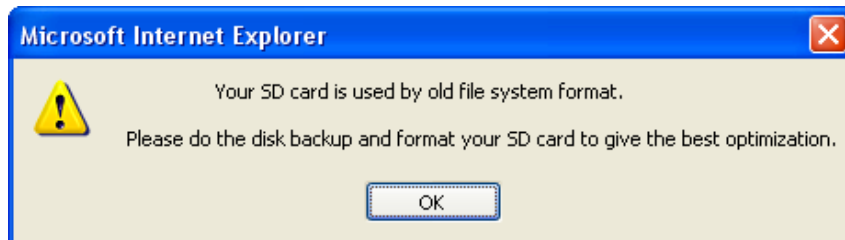

Figure 6-1

6.1.1 Using the Web Interface

1. In the Live View window, click the **Show System Menu** button (No. 9, Figure 3-3) and select **Remote Config**. This dialog box appears.

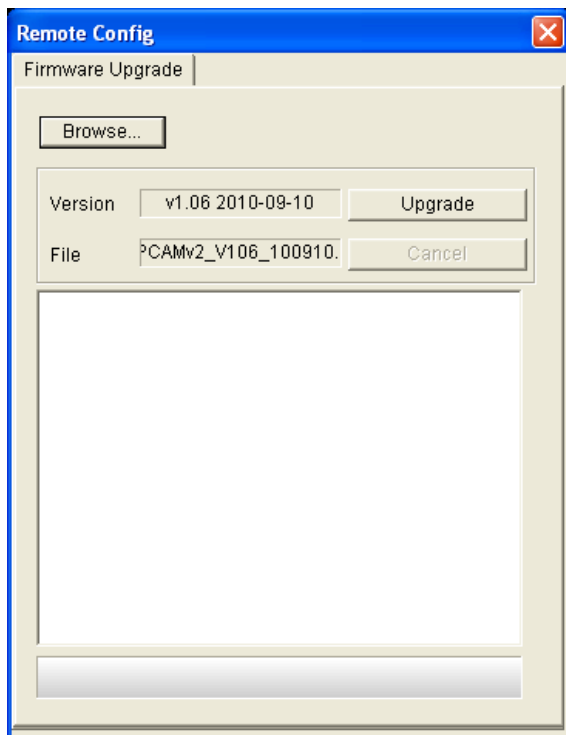

Figure 6-2

2. Click the **Browse** button to locate the firmware file (.img) saved at your local computer.
3. Click the **Upgrade** button to process the upgrade.

6.1.2 Using the GV-IP Device Utility

The GV-IP Device Utility provides a direct way to upgrade the firmware for multiple cameras. Note the computer used to upgrade firmware must be under the same network of the camera.

1. Insert the Software DVD, select **IP Device Utility**, and follow the onscreen instructions to install the program.
2. Double-click the **GV IP Device Utility** icon created on your desktop. This dialog box appears.

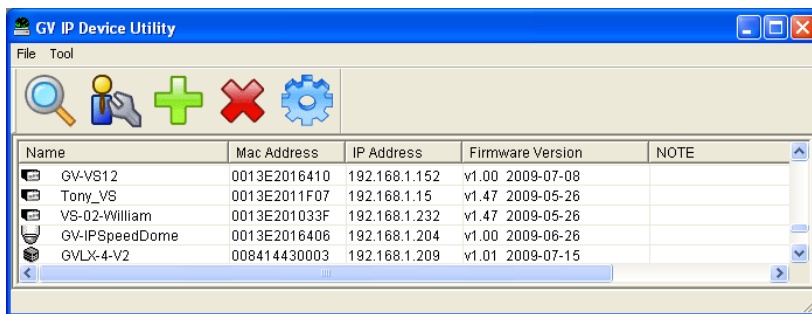



Figure 6-3

3. Click the **Search** button  to locate the available cameras on the same LAN. Or click the **New** button and assign the IP address to locate the camera over the Internet. Or highlight a camera in the list and click the **Delete** button to remove it.
4. Double-click a camera in the list. This dialog box appears.

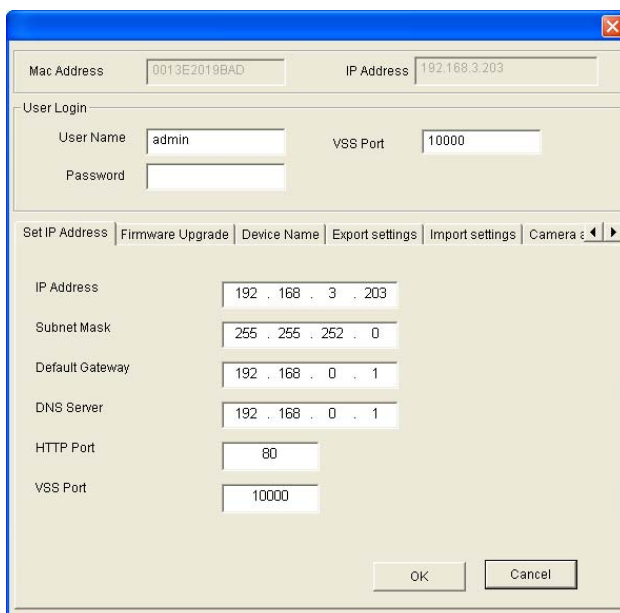

Figure 6-4

5. Click the **Firmware Upgrade** tab. This dialog box appears.

Mac Address: 0013E2019BAD IP Address: 192.168.3.203

User Login

User Name: admin VSS Port: 10000

Password: ***

Set IP Address | **Firmware Upgrade** | Device Name | Export settings | Import settings | Camera ε ◀ ▶

Version: v1.03 2011-03-25 Browse...

Upgrade all devices

Upgrade Cancel

Figure 6-5

6. Click the **Browse** button to locate the firmware file (.img) saved at your local computer.
7. If you like to upgrade all cameras of the same model in the list, check **Upgrade all devices**.
8. Type **Password**, and click **Upgrade** to process the upgrade.

6.2 Backing Up and Restoring Settings

With the GV-IP Device Utility included on the Software DVD, you can back up the configurations in the camera, and restore the backup data to the current unit or import it to another unit.

6.2.1 Backing Up the Settings

1. Run **IP Device Utility** and locate the desired camera. See Steps 1-3 in 6.1.2 *Using the GV-IP Device Utility*.
2. Double-click the camera in the list. Figure 6-4 appears.
3. Click the **Export Settings** button. This dialog box appears.

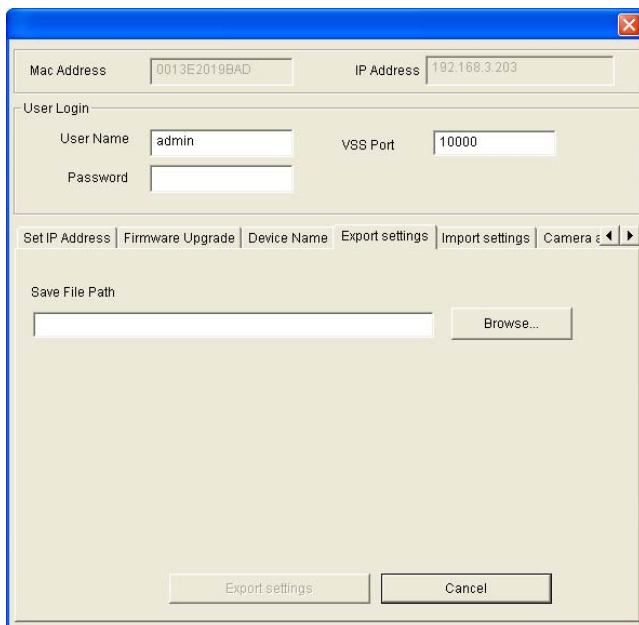

Figure 6-6

4. Click the **Browse** button to assign a file path.
5. Type **Password**, and click **Export Settings** to save the backup file.

6.2.2 Restoring the Settings

1. In Figure 6-4, click the **Import Settings** tab. This dialog box appears.

Figure 6-7

2. Click the **Browse** button to locate the backup file (.dat).
3. Select **Upgrade all devices** to apply the settings to all devices of the same model in the same LAN.
4. To import device name, password settings and/or network settings, select **Device Name**, **Password Settings** and/or **Network settings**.
5. Type the Password and click the **Update Settings** button to start restoring.

6.3 Restoring to Factory Default Settings

You can restore the camera to factory default settings using the Web interface or directly on the camera.

6.3.1 Using the Web Interface

To restore to default settings using the Web interface:

1. In the left menu, select **Management** and select **Tools**.
2. Under the **System Settings** section, click the **Load Default** button.

6.3.2 Directly on the Camera

1. Use the supplied torx wrench to unscrew and remove the camera cover.
2. Use a pointy object such as the tip of a pen to hold down the **Load Default** button.

GV-FE2301 / 4301



Figure 6-8

GV-FE3402 / 3403 / 5302 / 5303

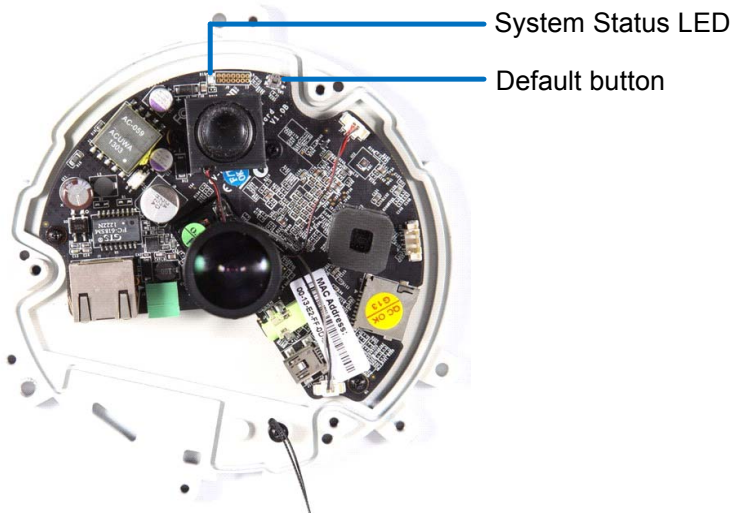

Figure 6-9

GV-FER3402 / 3403 / 5302 / 5303

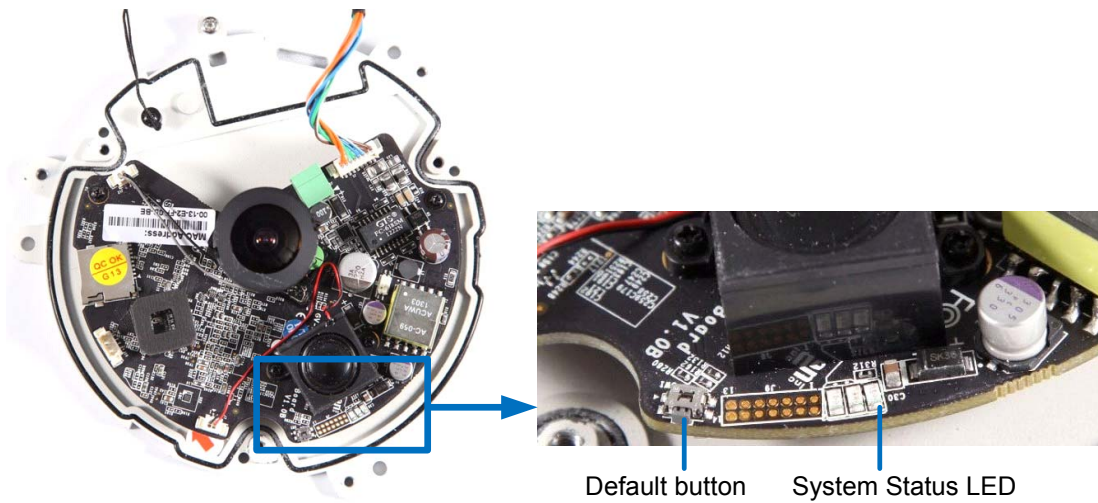

Figure 6-10

GV-FER12203

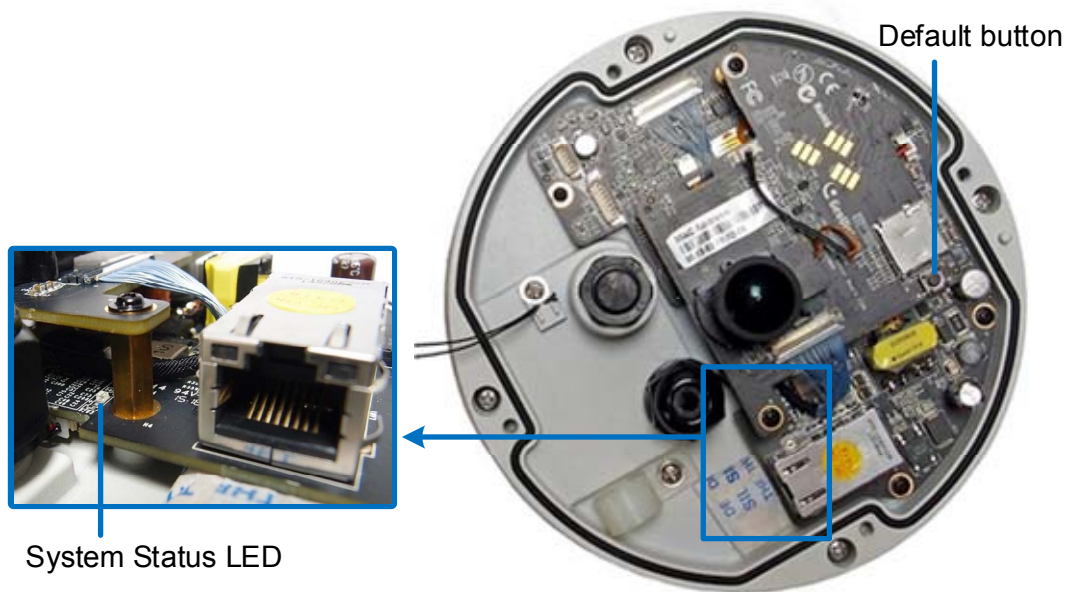

Figure 6-11

3. Release the default button when the status LED blinks.
4. When the status LED fades, the process of loading default settings is completed and the camera reboots automatically.

GV-UNFE2503

1. Keep the PoE cable connected to the main body.
2. Use a pin to press and hold the Load default button on the panel.



Figure 6-12

3. Release the default button when the status LED blinks. This shall take about 8 seconds.
4. When the status LED fades, the process of loading default settings is completed and the camera reboots automatically.

6.4 Changing Password

You change the login password of your GV-IP Camera using GV-IP Device Utility.

1. Make sure you have installed and executed GV-IP Device Utility. For details, see steps 1 to 3 in *6.1.2 Using the GV-IP Device Utility*. This page appears.

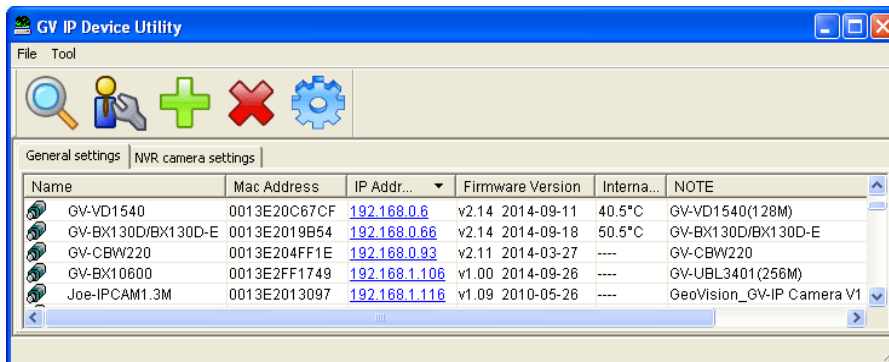

Figure 6-13

2. Double-click one camera in the list. This window appears.

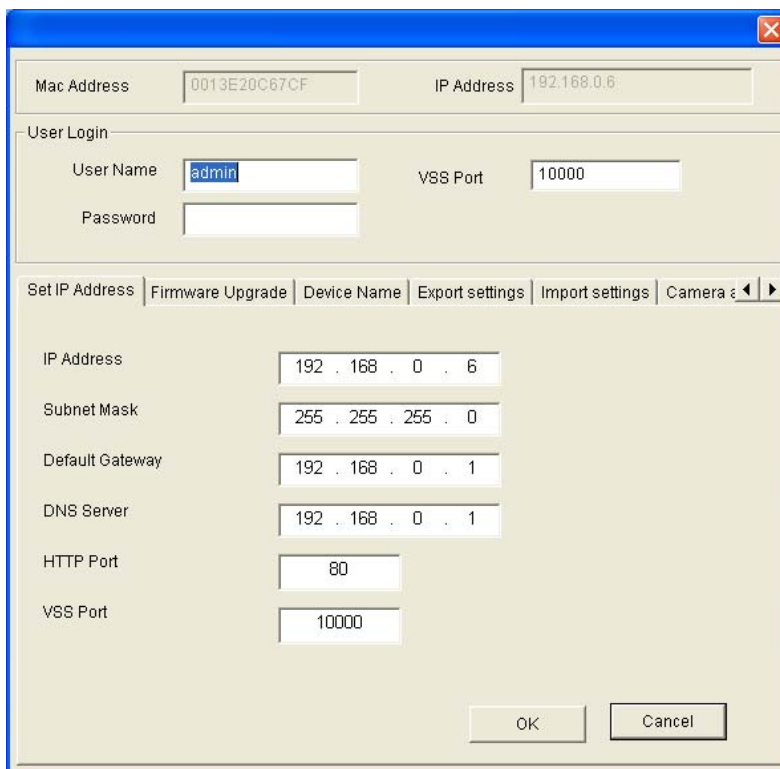

Figure 6-14

3. Type Password, click , select **Other Settings** and then select **Change Password**. This dialog box appears.

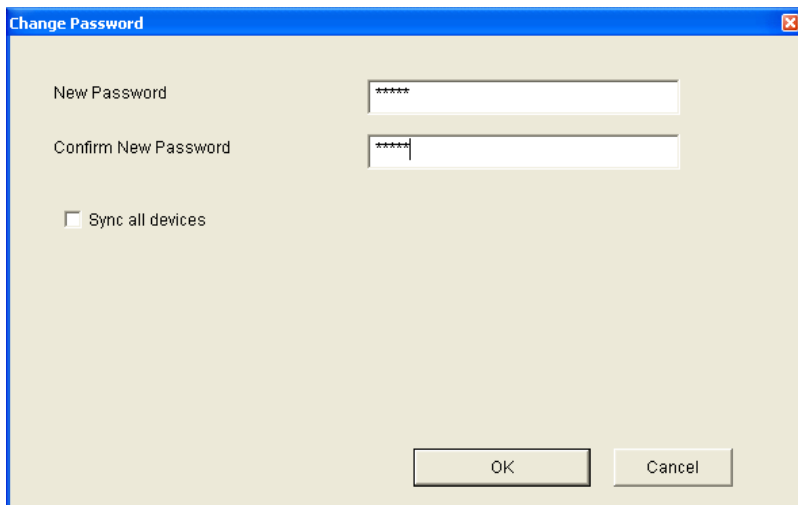

Figure 6-15

4. Type the new password in both fields. To change devices of the same type to the same password, select **Sync all devices**.
5. Click **OK** to apply the change.

6.5 Verifying Watermark

The watermark is an encrypted and digital signature embedded in the video stream during the compression stage, protecting the video from the moment of its creation. Watermarking ensures that an image is not edited or damaged after it is recorded. To enable the watermark function, see [Watermark], *4.1.1 Video Settings*.

The **Watermark Proof** is a watermark-checking program. It can verify the authenticity of the recording before you present it in court.

6.5.1 Accessing AVI Files

To verify watermark, first you have to access the recorded AVI files by one of these methods:

1. Use the **File Save** function on the Live View window (Figure 3-3) to start recording on the local computer.
2. Use the **Act as FTP Server** function to download AVI files from the camera. See *4.3.2 FTP*.
3. Use the files recorded on the memory card. Since the files saved on the memory card are of Linux file system, remember to run **IFS Drives** from the Software DVD to convert the Linux-based files to Windows-based files. For the instructions, see Steps 1 to 2 in *5.2.1 Playback Using the Memory Card*.

6.5.2 Running Watermark Proof

1. Install **Watermark Proof** from the Software DVD. After installation, a **WMPProof** icon is created on your desktop.
2. Double-click the created icon. The Water Mark Proof window appears.
3. Click **File** from the menu bar, select **Open** and locate the recording (.avi). The selected recording is then listed on the window. Alternatively, you can drag the recording directly from the storage folder to the window.
4. If the recording is unmodified, a check will appear in the **Pass** column. On the contrary, if the recording is modified or does not contain watermark during recording, a check mark will appear in the **Failed** column. To review the recording, double-click the listed file on the window.

6.5.3 The Watermark Proof Window

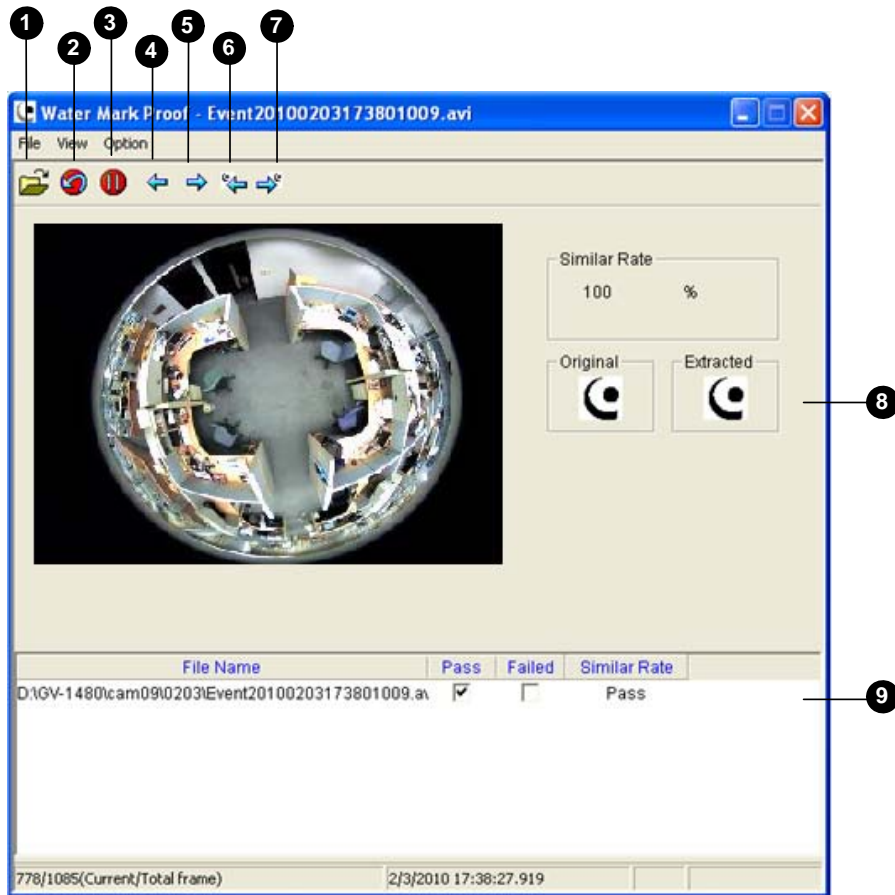

Figure 6-16

The controls in the window:

No.	Name	Description
1	Open File	Opens the recorded file.
2	First Frame	Goes to the first frame of the file.
3	Play	Plays the file.
4	Previous Frame	Goes to the previous frame of the file.
5	Next Frame	Goes to the next frame of the file.
6	Previous Watermarked Frame	Goes to the previous frame that contains watermark.
7	Next Watermarked Frame	Goes to the next frame that contains watermark.
8	Original vs. Extracted	The Extracted icon should be identical to the Original icon. If not, it indicates the recording has been tampered with.
9	File List	Displays the proof results.

6.6 Downloading Videos from the Micro SD Card

When connections of GV-IP Cameras to the GV-System are lost, recordings are automatically saved to the memory cards inserted in the GV-IP Cameras. To automatically synchronize and download recordings from the micro SD cards to a local folder, install and execute the **GV-SDCardSync Utility** program.

Note: GV-SDSyncCard Utility is only supported in GV-System V8.5.4 or later and in GV-IPCam H.264 V1.11 or later.

6.6.1 Installing the GV-SDCardSync Utility

1. Download the **GV-SD Card Sync Utility** program from http://ftp.geovision.tw/FTP/neo/Utility/GvSDCardSync_Setup.zip

Note: The GV-SD Card Sync Utility must be installed on the computer installed with GV-System V8.5.4 or later.

2. Execute the **GV-SDCard Sync Utility** program. The main window and the Setting window appear. The Setting window pops up automatically upon first execution. Otherwise, click the **Setting** button .

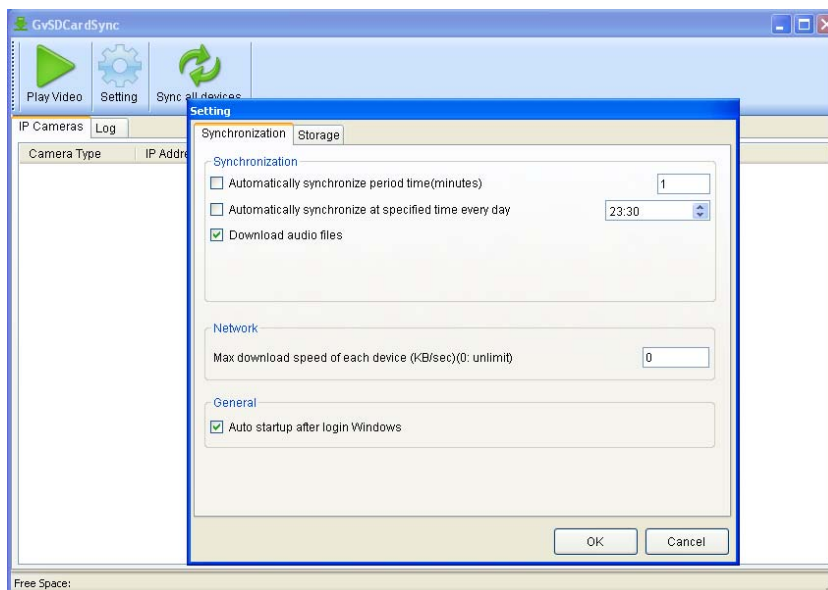

Figure 6-17

3. To configure synchronization, network and startup settings, see the steps below.

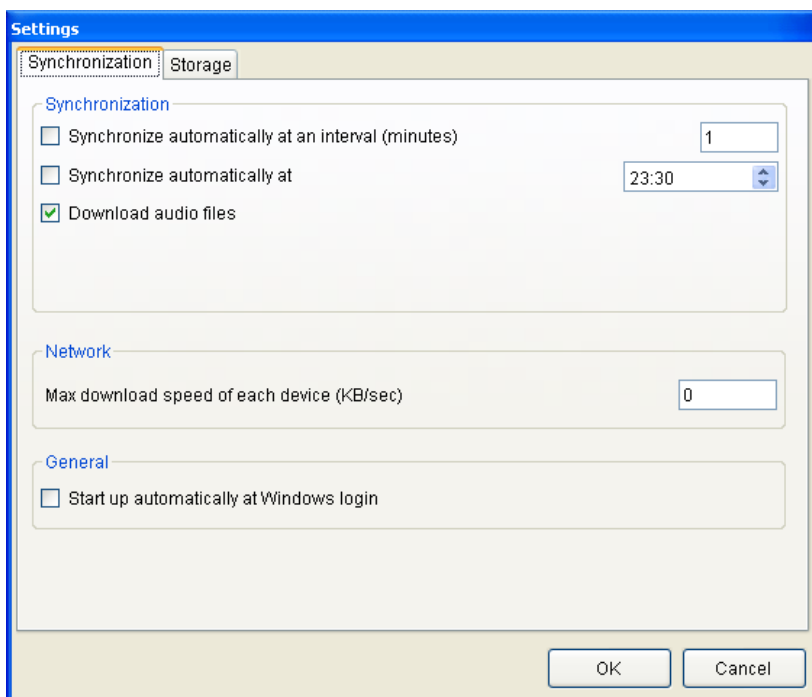

Figure 6-18

[Synchronization]

- **Synchronize automatically at an interval:** Automatically synchronize videos from micro SD cards to a local folder at the specified interval.
- **Synchronize automatically at:** Automatically synchronize videos from micro SD cards to a local folder at the specified time.
- **Download Audio Files:** You may choose to download audio files along with the video files. This option is enabled by default.

[Network]

- **Max. download speed of each device (Kb/sec):** To make sure the bandwidth is not completely taken up while downloading files from the memory card, specify a maximum download speed. If you do not want to set a bandwidth limit, type **0**.

[General]

- **Start up automatically at Windows login:** GV-SDSync Utility launches automatically when Windows starts up.

- By default, downloads are saved to **:\GvSDCardSync** and are not recycled automatically. To configure the storage and recycling settings, select the **Storage** tab on the Setting window. This page appears.

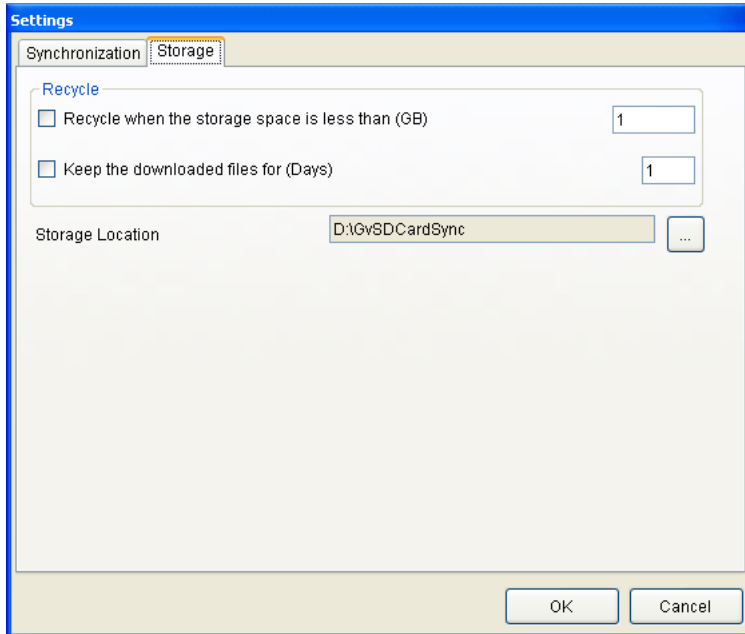

Figure 6-19

[Recycle]

- **Recycle when the storage space is less than (GB):** Specify a minimum free space of your local storage for file recycling.
- **Keep the downloaded files for (Days):** Specify the number of days to keep the download files at the local hard drive.

[Storage Location]

To configure the storage path, click the button next to the location field and specify a storage location.

- Click **OK** to save the configuration or exit the Setting window.

Note: Keep the GV-SDCardSync Utility running in the background to automatically synchronize and download videos.

6.6.2 The GV-SDCardSync Utility Window

After you have installed the GV-SDCardSync Utility, point to **Start**, select **Programs**, select **GV-SDCardSync** and select  to launch the program. This window appears.

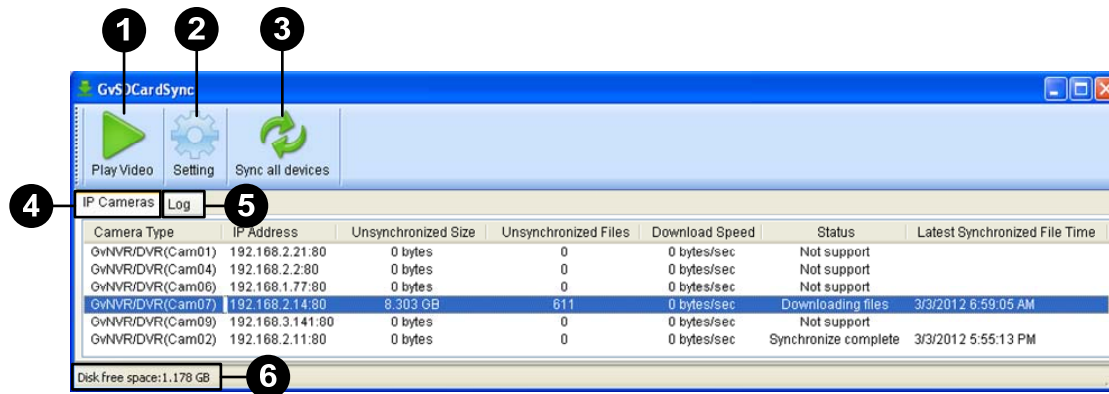

Figure 6-20

No.	Name	Description
1	Play Video	Plays downloaded recordings of the selected GV-IP Cameras using the ViewLog player. For details, see Chapter 4, <i>DVR User's Manual</i> on Surveillance System Software DVD.
2	Setting	Contains settings on synchronization, network, storage location and recycling criteria. See step 4 in 6.6.1 <i>Installing the GV-SDCardSync Utility</i> .
3	Sync all devices	Manually synchronizes and downloads the recording files stored at GV-IP Cameras.
4	IP Camera Tab	Shows information of GV-IP Cameras connected to the GV-System, including channel number, IP address, size and number of unsynchronized files, download speed, status and the last synchronization time.
5	Log Tab	Displays up to 100 event entries of the GV-SDCardSync Utility. Once the entries are full, recycling will start from the oldest file.
6	Storage Space	Shows the storage space of the designated hard drive.

Note:

1. The synchronization time is recorded according to the system time of the GV-IP Camera.
2. The logs are deleted once the GV-SDCardSync Utility is re-activated.

Chapter 7 DVR Configurations

The GV-System / GV-VMS provides complete video management, such as video viewing, recording, playback, alert settings, and almost every feature of the system. The integration specifications are listed below:

- The compatible GV-System and GV-VMS version for each GV-Fisheye Camera model:

Camera Model	Compatible GV-System	Compatible GV-VMS	
GV-FE2301 / 4301	V8.5.6 (with patch files) or later	V14.10 or later	
GV-FE3402 / 3403 GV-FE5302 / 5303 GV-FER3402 / 3403 GV-FER5302 / 5303	V8.5.9 or later		
GV-FER12203	V8.6.2.0 (with patch files) or later		V14.10.1.0 (with patch files) or later
GV-UNFE2503	V8.6.2.0 (with patch files) or later		V14.10.1.0 (with patch files) or later

- The maximum number of streams supported by each GV-Fisheye Camera is detailed below.

Camera Models	Max. No. of Streams
GV-FE3402 / 3403 GV-FER3402 / 3403	4
GV-FE4301	4
GV-FE2301 GV-FE5302 / 5303 GV-FER5302 / 5303	5
GV-FER12203	8
GV-UNFE2503	8

- When a GV-Fisheye Camera is connected to IE browser or any other applications, it takes up 1 stream; when it is connected to GV-System / GV-VMS, it takes up 2 streams.

Note: By default, GV-Fisheye Camera is in dual streams and will take up 2 streams when connected to GV-System / VMS.

- The hardware compression and the “Pre-Recording Using RAM” feature cannot work on the videos from the fisheye camera.

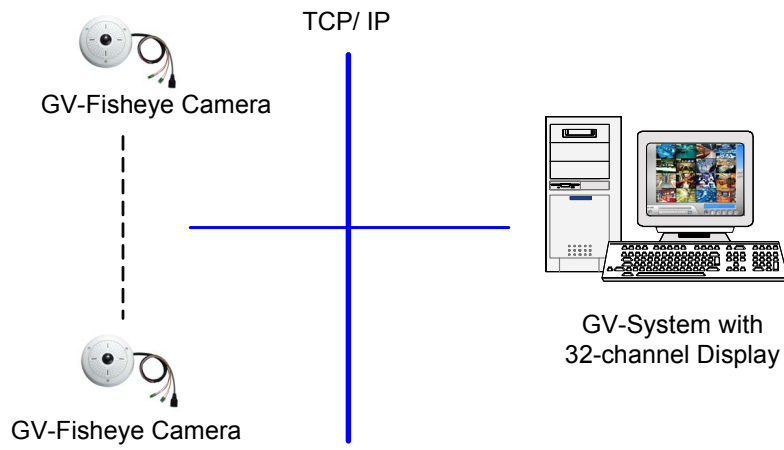

Figure 7-1

7.1 Setting Up IP Cameras on GV-System

To set up the camera on the GV-System, follow these steps:

1. On the main screen, click the **Configure** button, select **System Configure**, select **Camera Install** and click **IP Camera Install**. This dialog box appears.

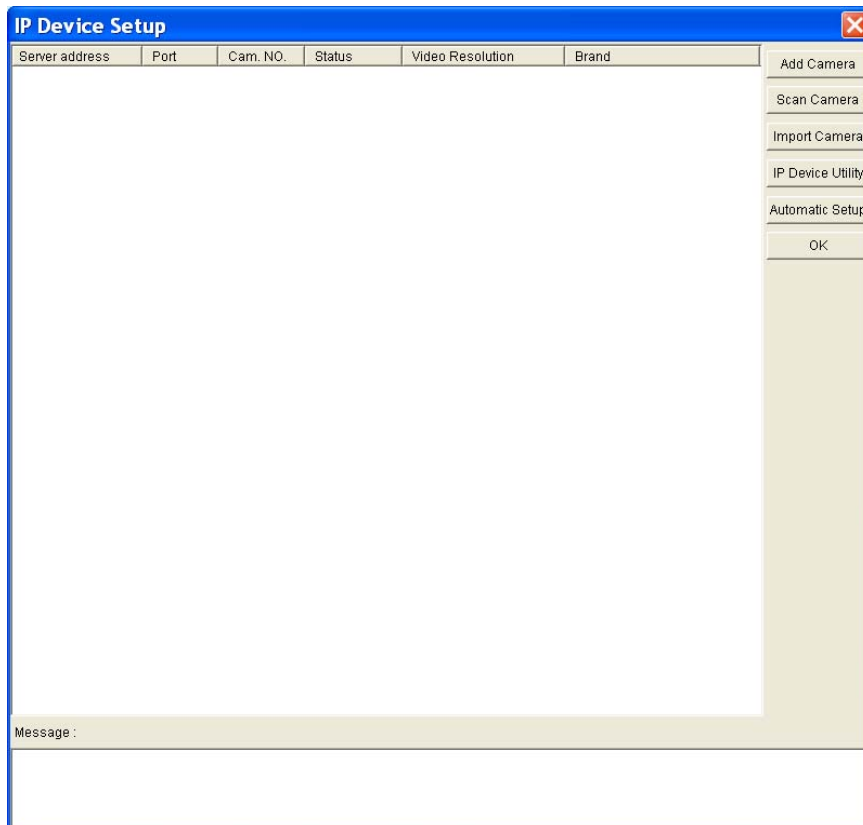

Figure 7-2

- To automatically set up the camera, click **Scan Camera** to detect any GV IP devices on the LAN.
- To manually set up the camera, click **Add Camera**.

The following steps are the example of manual setup.

2. Click **Add Camera**. This dialog box appears.

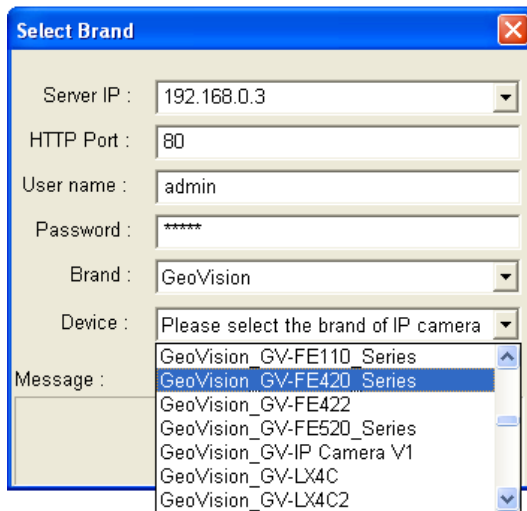

Figure 7-3

3. Type the IP address, username and password of the camera. Modify the default HTTP port if necessary. Select **GeoVision** from the **Brand** drop-down list and select the model from the **Device** drop-down list. This dialog box appears.

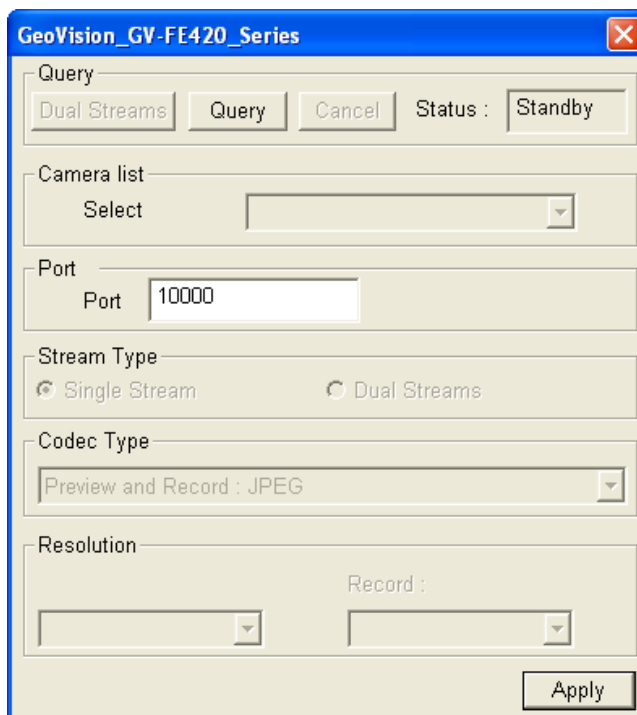

Figure 7-4

4. Click **Query** to acquire the information from the IP camera. You can change the video streaming port number if needed.
5. Click **Apply**. The IP camera is added to the connection list.

- Click the listed camera and select **Display position** to map the IP camera to a channel on the GV-System.

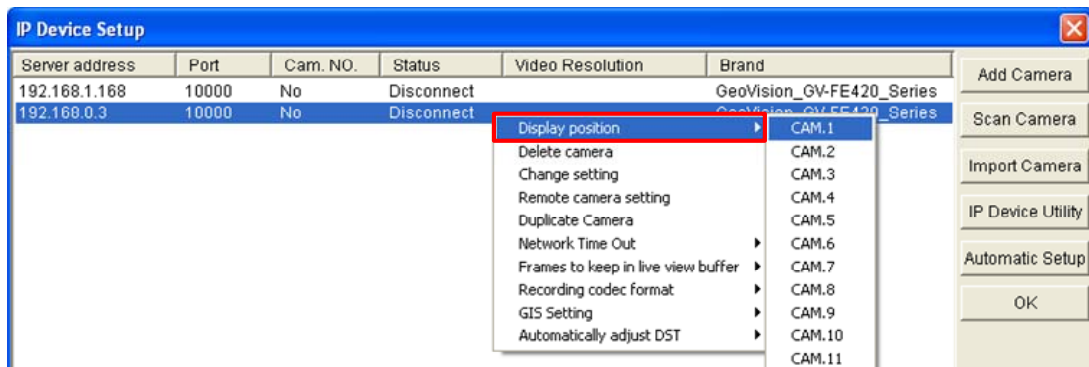

Figure 7-5

- The Statue column should display "Connected". Click **OK**.

7.1.1 Customizing the Basic Settings on GV-System

After the GV-Fisheye Camera is connected and assigned with a display position, you can configure the camera's settings such as frame rate, codec type and resolution. Right-click the desired camera to see the following list of options:

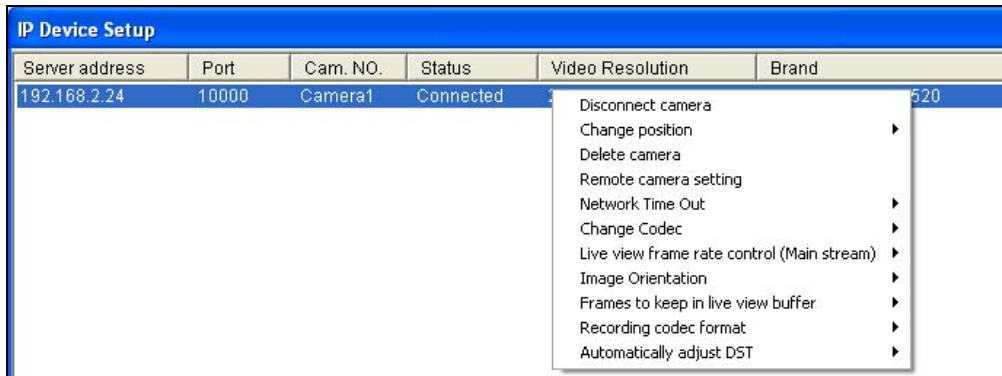





Figure 7-6

- **Network Time Out:** When network disconnection exceeds the specified time period, the camera status will be displayed as Connection Lost.
- **Change Codec:** Changes the code type.
- **Live-view frame rate control (Main stream):** Sets the live view frame rate of the sub stream to help reduce the CPU usage. If you have set the live view codec to be MJPEG, select the number of frames to allow in a second. If the live view codec selected is H.264, select one of the following options:
 - ⊙ **Maximum Live-view Frame Rate:** View the video at the maximum frame rate possible.
 - ⊙ **Live-view Key Frame only:** You can choose to view the key frames of the videos only instead of all frames on the live view. This option is related to the GOP setting of the IP camera. For example, if the GOP value is set to 30, there is only one key frame among 30 frames.
- **Image Orientation:** You can adjust the image orientation by selecting **Normal**, **Horizontal Mirror**, **Vertical Flip** or **Rotate 180°**.
- **Frames to keep in live view buffer:** Specifies the number of frames to keep in the live view buffer.
- **Recording Codec Format:** Specifies whether to record in standard or GeoVision type of MJPEG, H.264 codec.
- **Automatically Adjust DST:** If enabled, the time on the GV-IP device Web interface will be synchronized with the time of the GV-System when DST period starts or ends on the GV-System.

7.2 Setting Up IP Cameras on GV-VMS

Follow the steps below to manually connect your GV-Fisheye IP Dome to GV-VMS.

Note: The following instructions are based on V14.10 software and user interfaces.

1. To access the IP Device Setup page, click **Home** , select **Toolbar** , click **Configure**  and select **Camera Install**.

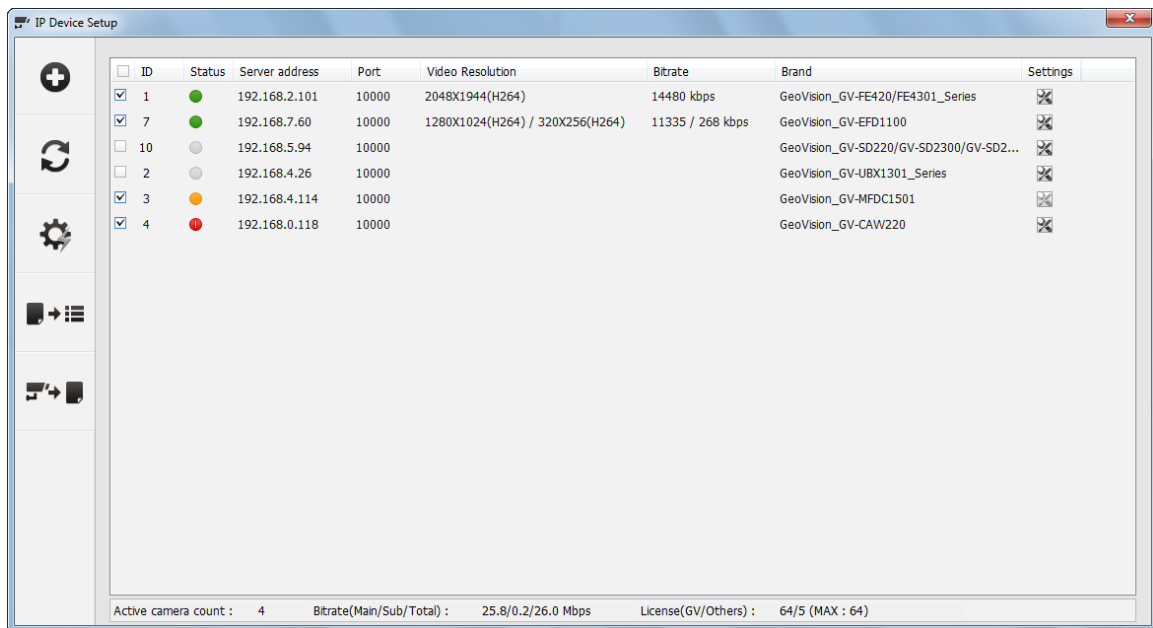

Figure 7-7

2. Click **Add Camera** . This dialog box appears.

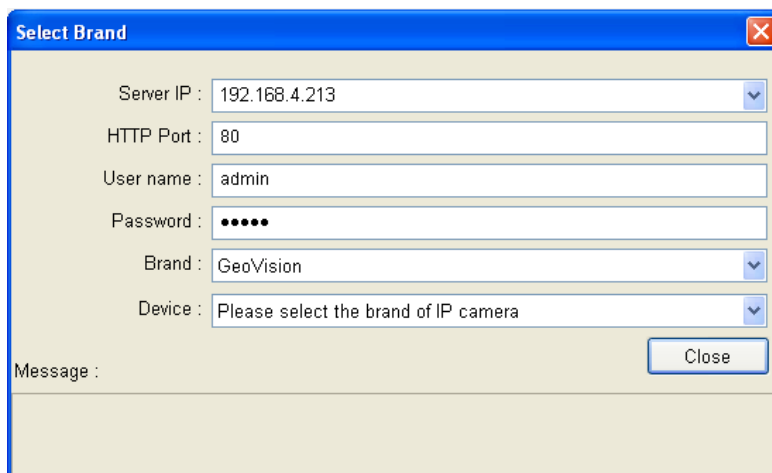

Figure 7-8

3. Type the IP address, username and password of the camera. Modify the default HTTP port **80** if necessary.

- Select **GeoVision** and model name from the **Brand** drop-down list and select the camera from the **Device** drop-down lists. This dialog box appears.

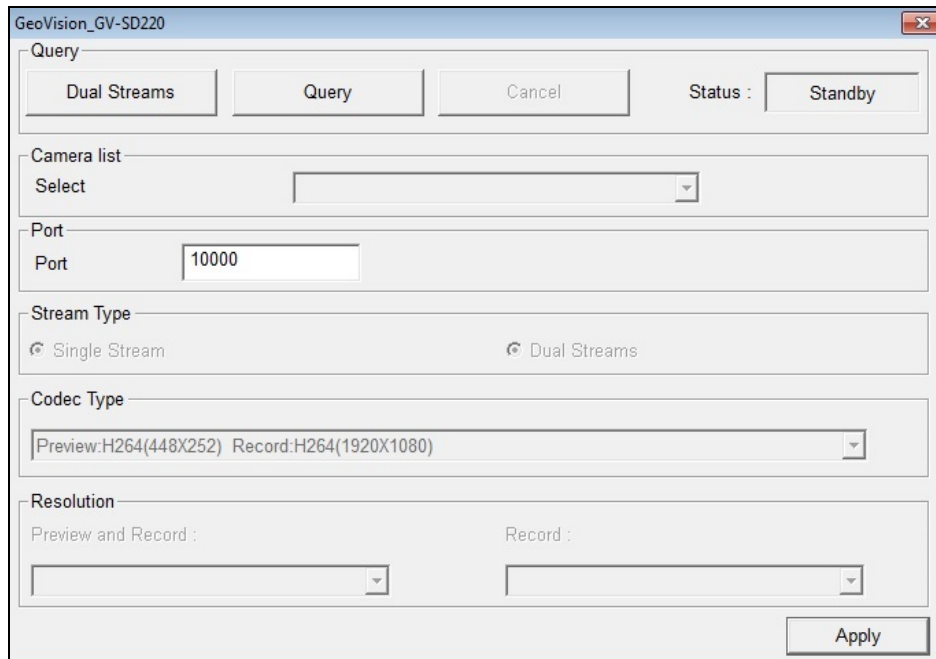

Figure 7-9

- In the dialog box, configure the options which may vary depending on camera brands.
 - **Dual Streams:** The camera is set to dual streams by default. Select this option to apply the dual-streaming settings (lower resolution for live view and higher resolution for recording) if the camera supports dual streams.
 - **Query:** Detect and apply the current codec and resolution setting on the camera. This function may not be available for some third-party cameras.
 - **Camera list:** Select a camera number.
 - **Port:** Modify the video streaming port number if necessary.
 - **Stream Type:** You may have the option of **Single Stream** or **Dual Streams**.
 - **Codec Type:** You may have different codec options depending on camera models. If the selected camera supports dual streaming, the live view codec and recording codec can be set differently.
 - **Resolution:** You may select the different resolutions for live view and recording.
- Click **Apply** to add the camera to the list.

- To connect the added camera, click the box besides the **ID** column. Upon successful connection, the **Status** icon shows green, with the video resolution and bit rate being displayed in the correspondent columns.



<input checked="" type="checkbox"/>	ID	Status	Server address	Port	Video Resolution	Bitrate	Brand	Settings
<input checked="" type="checkbox"/>	1		192.168.7.52	10000	2560X1920(H264)	4955 kbps	GeoVision_GV-FE5302/3	

Figure 7-10

7.3 Remote Monitoring with Multi View

You can use the Multi View to monitor and manage the camera.

Note: Multi View is not supported by GV-VMS.

7.3.1 Connecting to the IP Camera

1. On the Multi View window, click the **Edit Host** button. The Edit Host window appears.
2. To create a host, click the **New** button. You need to create a group before creating a host.
3. Select **GV-IP Camera**, **GV-IP Speed Dome** from the Device drop-down list. Type the host name, IP address, user name and password of the camera. Modify the default VSS port **10000** if necessary.

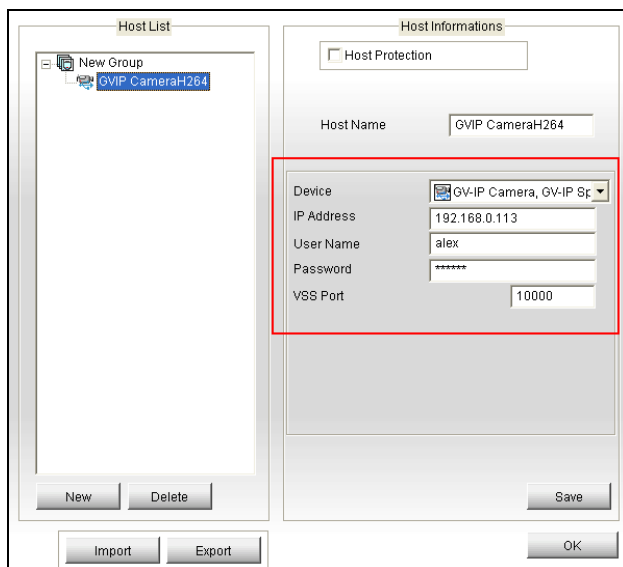

Figure 7-11

4. Click **Save** to establish connection.

For details on the Multi View functions, see “Multi View Viewer”, *Remote Viewing*, *DVR User’s Manual* on the Surveillance System Software DVD.

7.4 Remote Monitoring with E-Map

You can use the Remote E-Map to monitor and manage the camera.

7.4.1 Creating an E-Map for the IP Camera

With the E-Map Editor, you can create an E-Map for the camera. The E-Map Editor is available in the two applications: Main System and E-Map Server. The following is an example of running the E-Map Editor included in the Main System.

1. Go to Windows **Start** menu, point to **Programs**, select **GV folder** and click **E-Map Editor**.
2. To create an E-Map, click the **Add Map** button on the toolbar. A New Map file appears.
3. Double-click the New Map file, and click the **Load Map** button on the toolbar to import a graphic file.
3. To create a host, click the **Add Host** button on the toolbar and select **Add Camera**.
4. Right-click the created New Host in the Host View, and select **Host Settings**. This dialog box appears.

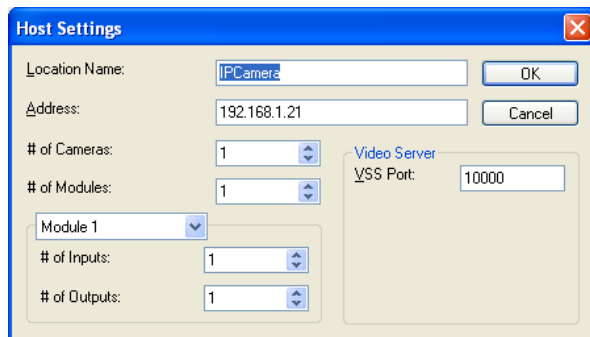

Figure 7-12

4. Give the camera a location name, and type its IP address (or domain name). Modify the default VSS port **10000** if necessary.
5. Click **OK** to save the settings.
6. Expand the created host folder. Drag and drop the icons of cameras and I/O devices onto the imported E-Map.
7. Close the E-Map Editor. Click **Yes** when you are promoted to save the file.

For details on creating an E-Map file on the E-Map Server, see “E-Map Server”, *E-Map Application, DVR User’s Manual* on the Surveillance System Software DVD.

7.4.2 Connecting to the IP Camera

Depending on where you save the created E-Map file (DVR, E-Map Server or Control Center), the steps to open the Remote E-Map window for monitoring may vary slightly. The following is the connection example when you store the E-Map file on the DVR.

1. To enable the remote access to the DVR, click the **Network** button, select **WebCam Server** to display the Server Setup dialog box, and click **OK** to start the WebCam server.
2. At the local computer, open the web browser and type the address of the DVR. The Single View page appears.
3. Select **Emap**. A valid user name and password are required for login. For the first-time user, you will be directed to the Download page. Install the E-Map program before you can run it.
4. On the Remote E-Map window, click the **Login** button and select the camera host to access its videos and I/O devices. A valid user name and password are required to log in the camera.

For details on the Remote E-Map functions, see “The Remote E-Map Window”, *E-Map Application, DVR User’s Manual* on the Surveillance System Software DVD.

Chapter 8 CMS Configurations

This section introduces settings on connecting the camera in the central monitoring stations Center V2, Vital Sign Monitor and Dispatch Server.

8.1 Center V2

The Center V2 can monitor and manage the camera and I/O devices connected to the camera.

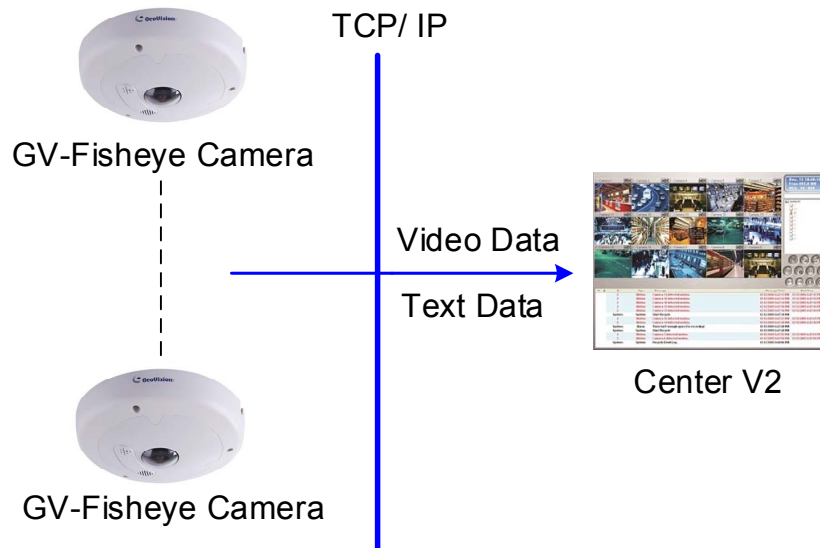

Figure 8-1

- To set the appropriate port connecting to the IP camera, click the **Preference Settings** button, select **System Configure**, click the **Network** tab, and check **Accept connections from GV-Compact DVR, Video Server & IP Cam**. Keep the default port 5551 for the Port 2 option, or modify it to match the Center V2 port on the camera.

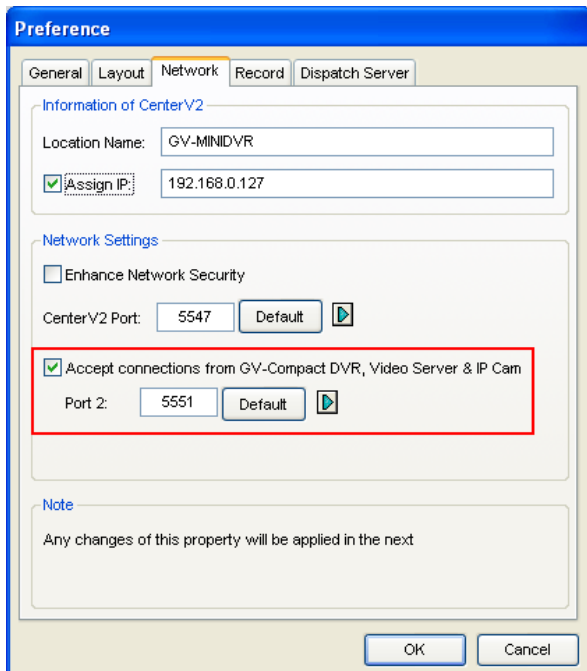

Figure 8-2

- To define how to display the received video on motion detection and input trigger from the camera, click the **Preference Setting** button and select **System Configure**. This dialog box appears.

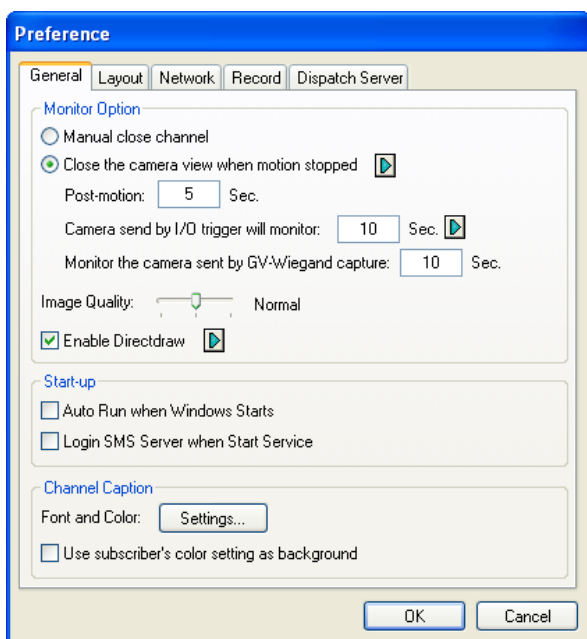

Figure 8-3

- **Manual close channel:** Closes the triggered camera view manually.
- **Close the camera view when motion stopped:** Closes the triggered camera view automatically when motion stops.
- **Post Motion:** Specify the duration of the camera view remaining on the monitoring window after motion stops.
- **Camera send by I/O trigger will monitor:** Specify the duration of the camera view remaining on the monitoring window when an I/O device is triggered.

To keep the camera view remaining on the monitoring window even after the alarm is finished, click the right-arrow button, and uncheck **Latch Trigger**. Then the camera view will keep remaining on the monitoring window for the specified time. For example, the alarm is triggered for 5 minutes and you set 10 minutes, which means the total display time will be 15 minutes.

For further information on how to manage the video received from the camera, see *GV-CMS Series User's manual*.

8.2 Vital Sign Monitor

The Vital Sign Monitor can monitor and manage the camera and I/O devices connected to the camera.

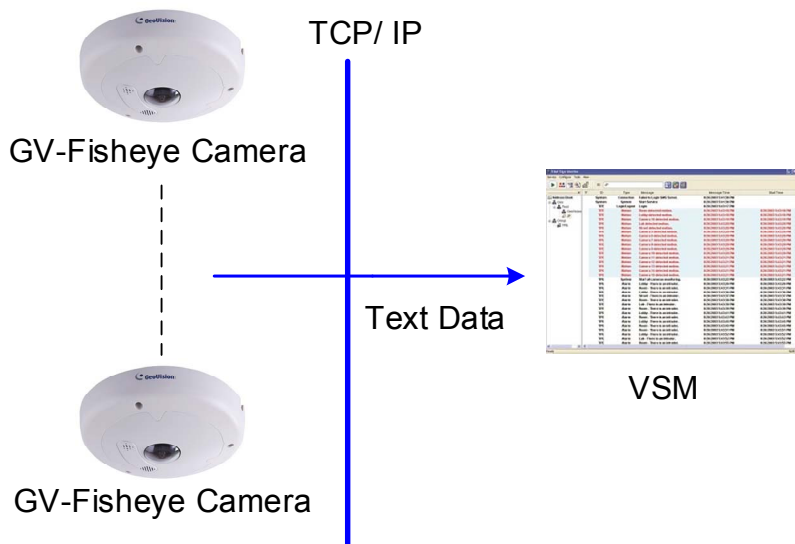

Figure 8-4

To set the appropriate port connecting to the camera, click **Configure** on the window menu, and select **System Configure** to display this dialog box. In the **Connective Port** field, keep the default value **5609** for the Port 2 option, or modify it to match the Vital Sign Monitor port on the camera.

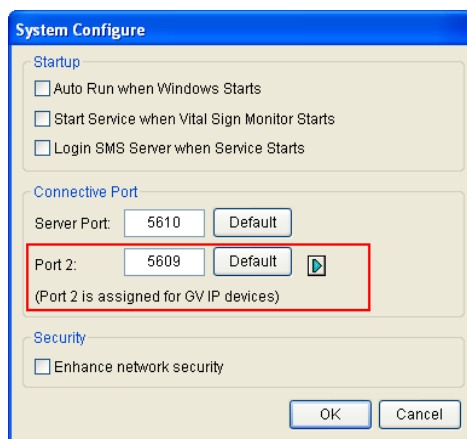

Figure 8-5

For further information on how to manage the video received from the camera, see *GV-CMS Series User's manual*.

8.3 Dispatch Server

The Dispatch Server can manage the camera and I/O devices connected to the camera, and distribute them to the Center V2.

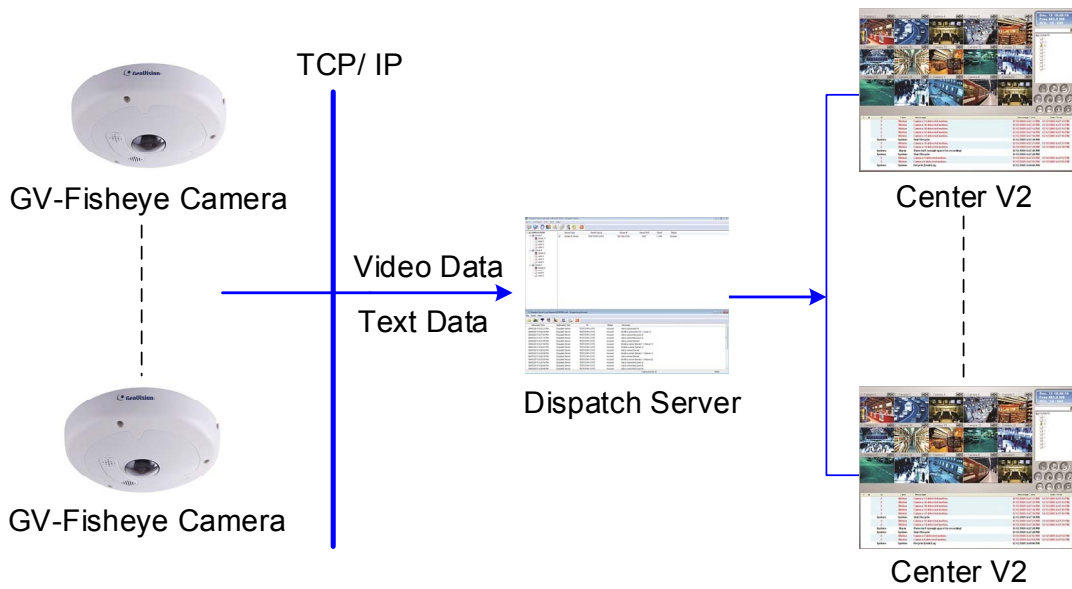

Figure 8-6

To enable connecting to the camera, click the **Setting** button on the toolbar, and select **Allow GV IP devices to login as subscriber from port**. Keep the default port **5551**, or modify it to match the Center V2 port on the camera.

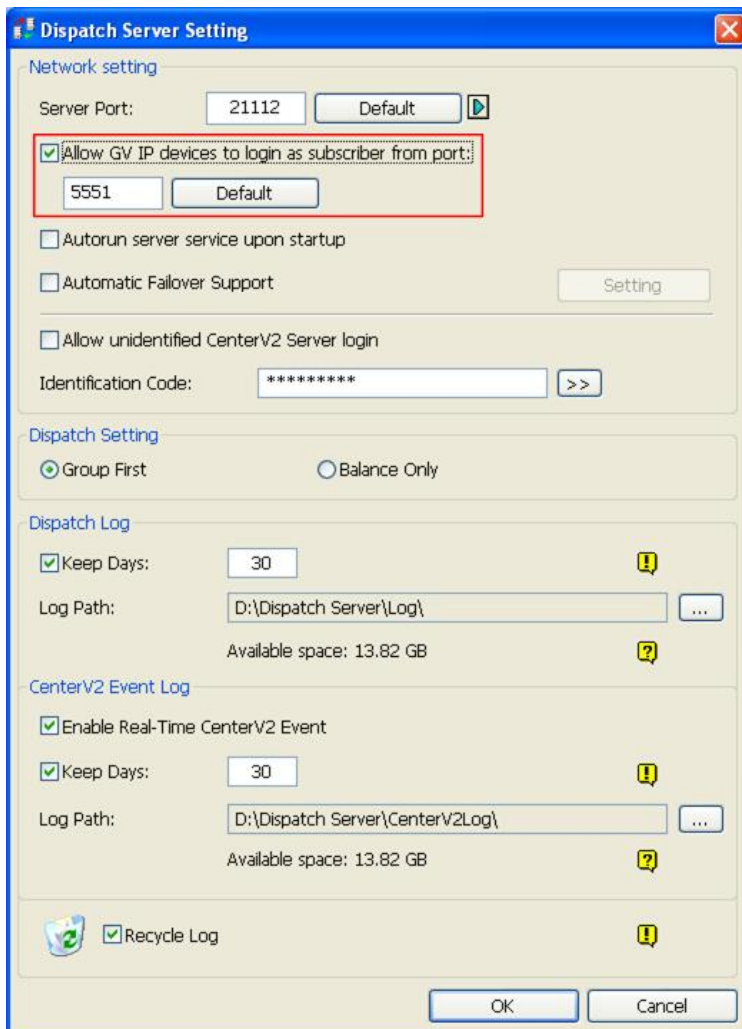

Figure 8-7

For further information on how to manage the video received from the camera, see *GV-CMS Series User's manual*.

Appendix

A. Settings for Internet Explore 8 or later

If you use Internet Explorer 8 or later, it is required to complete the following setting.

1. Set the Security to **Medium-high (default)**.
2. Enable **Allow previously unused ActiveX controls to run without prompt**.
3. Disable **Only allow approved domains to use ActiveX without prompt**.

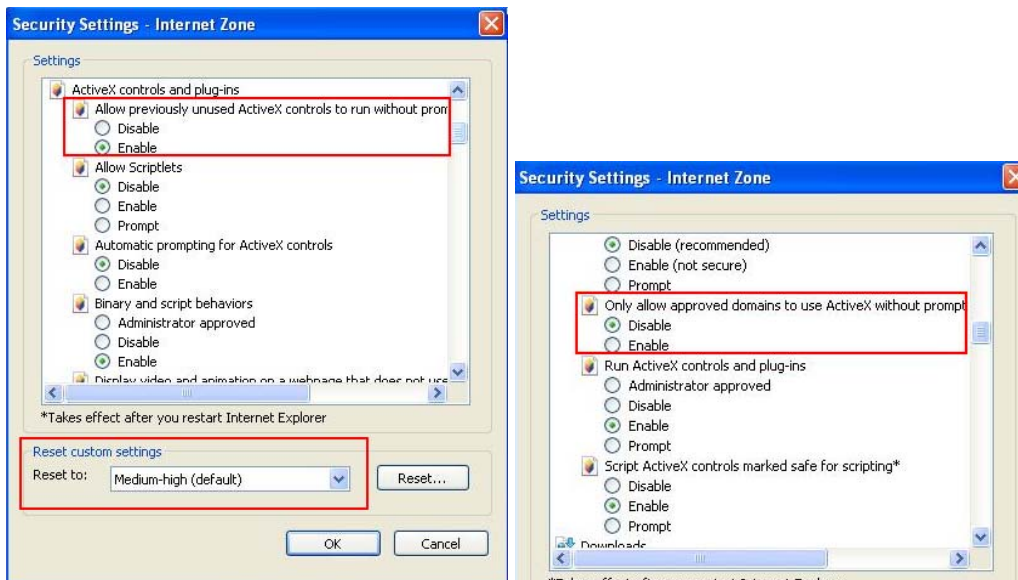

B. RTSP Protocol Support

The fisheye camera can support RTSP protocol for both video and audio streaming.

If you are using Quick Time player, use the following RTSP command:

```
rtsp://<IP of the fisheye camera>:8554/<CH No.>.sdp
```

For example, `rtsp://192.168.3.111:8554/CH001.sdp`

If you are using VLC player, use the following RTSP command:

```
rtsp://<ID>:<Password>@<IP of the camera>:8554/<CH No.>.sdp
```

For example, `rtsp://admin:admin@192.168.3.111:8554/CH001.sdp`

If you use the VLC, and if authentication is *not* required, enter:

```
rtsp://@<IP of the GV-IPCAM H.264>:8554/<CH No.>.sdp
```

For example, `rtsp://@192.168.3.111:8554/CH001.sdp`

Note:

1. RTSP streaming is supported over HTTP, UDP and TCP.
 2. The video streaming through RTSP protocol can only be displayed in circular source images.
 3. The RTSP protocol must be enabled on the Web interface. See [4.3.8 RTSP](#).
 4. Only VLC and QuickTime players are supported for streaming video via RTSP protocol.
-

C. The Supported Mobile Broadband Devices

Brand	Model
Huawei	E220, E392
	E169, E1692, E156, EC189, E1752, E1756, E1756C, E169C
Novatel	MC998D
	USB760, USB727, MC950D
ONDA	MSA523HS
ZTE	MF100

D. The CGI Command

You can use the CGI command to obtain a snapshot of the live view without logging in the Web interface or to access the User Account Web interface. For a fisheye camera with the following details:

IP address: 192.168.2.11

Username: admin

Password: admin

Desired stream: 1

Type the following into your web browser to **obtain a snapshot**:

<http://192.168.2.11/PictureCatch.cgi?username=admin&password=admin&channel=1>

Type the following into your web browser to **access the User Account Web interface**:

<http://192.168.2.11/ConfigPage.cgi?username=admin&password=admin&page=UserSetting>

E. Supported Firmware for Flash Memory

The 128 MB flash memory is supported in firmware V1.09 or later.

To look up if the camera contains a 128 MB type flash memory, access the web interface or the GV-IP Device Utility:

- **Web Interface**

Click **Management** and click **Tools**. The “128 MB” should be noted after the firmware version.



- **GV-IP Device Utility**

The “128 M” should appear under the NOTE column.

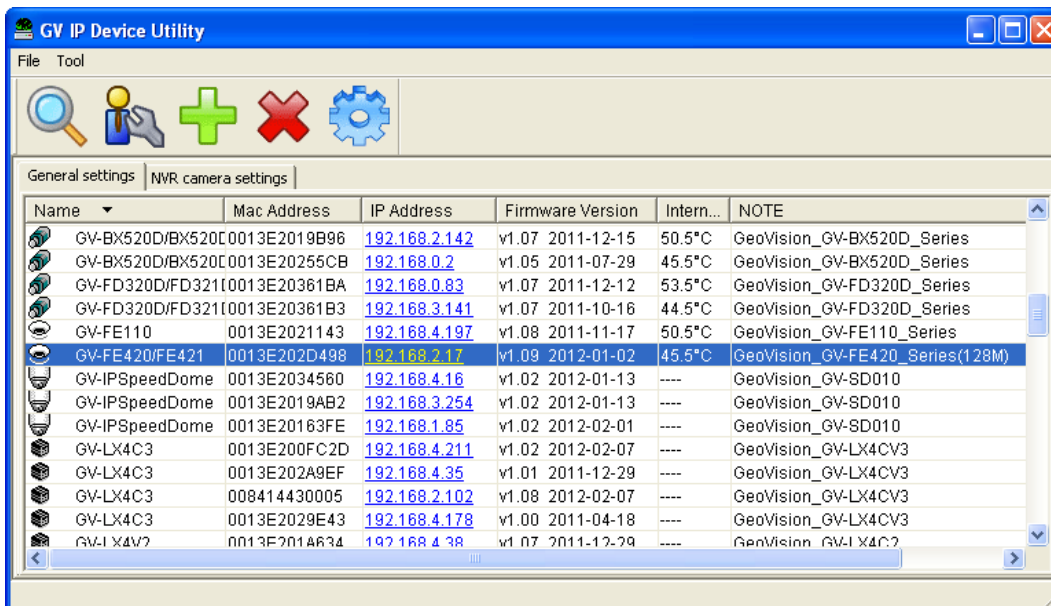

F. How to Remotely Reboot IP Cameras via FTP

Note this function is only available for GV-FER12203 firmware V1.02 or later.

1. Enable **Act as FTP server** under the FTP setting page.

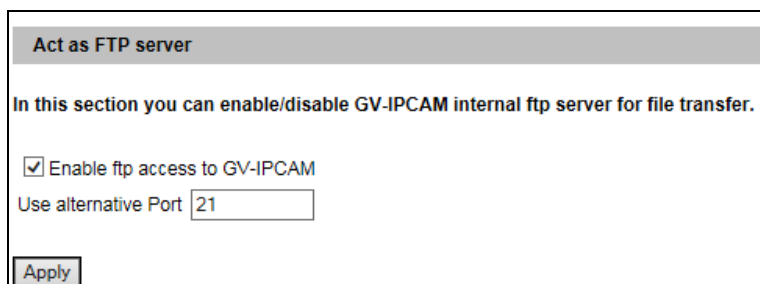

Act as FTP server

In this section you can enable/disable GV-IPCAM internal ftp server for file transfer.

Enable ftp access to GV-IPCAM

Use alternative Port

2. In CMD.exe, type ftp <IP address of the camera>, e.g. ftp 192.168.0.10.
3. Type your account name and password.
4. Type **quote site reboot**. The camera will be rebooted as indicated in the photo below.

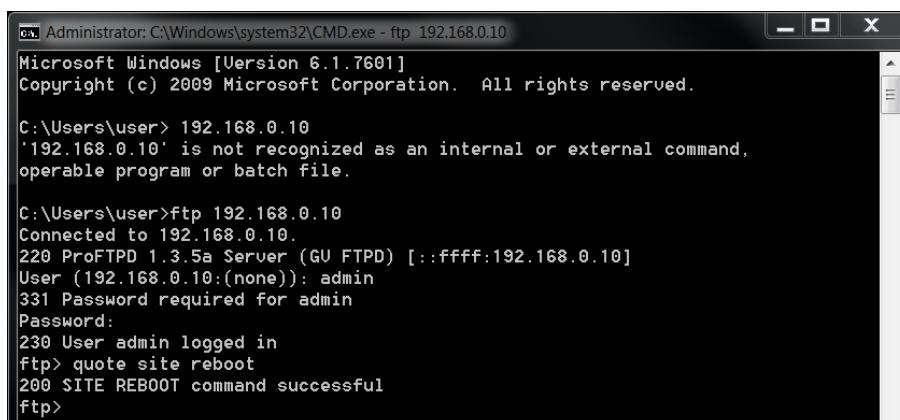

```
Administrator: C:\Windows\system32\CMD.exe - ftp 192.168.0.10
Microsoft Windows [Version 6.1.7601]
Copyright (c) 2009 Microsoft Corporation. All rights reserved.

C:\Users\user> 192.168.0.10
'192.168.0.10' is not recognized as an internal or external command,
operable program or batch file.

C:\Users\user>ftp 192.168.0.10
Connected to 192.168.0.10.
220 ProFTPD 1.3.5a Server (GU FTPD) [::ffff:192.168.0.10]
User (192.168.0.10:(none)): admin
331 Password required for admin
Password:
230 User admin logged in
ftp> quote site reboot
200 $SITE REBOOT command successful
ftp>
```