

SY-ENC35028

3.5" 2-BAY RAID Storage Enclosure

User Manual

1 Introduction

1.1 Features

- Supports JBOD, RAID0,RAID1,Normal mode
- Enhanced data protection and high -performance storage
- Automatic disk rebuild (Under SAFE Mode)
- Supports USB3.0 high speed to reach 5.0Gbps
- Supports Plug-play and Hot-plug
- Supports mode select via jumper setting

1.2 Specifications

Inner Interface: SATA

Outer Interface:USB3.0

Date Transfer rate: Support USB 3.0 super-speed (5Gbps),

Complies with USB 2.0 high speed (480Mbps),USB 1.1 Full speed (12Mbps)

Suitability: 2 x 3.5" SATA I/II/III HDD

Supports Plug-play and Hot-plug

Power Supply: AC 100~240V, 50~60Hz ; DC 12V, 2.5A

Material: Aluminum

Cooling Fan: One 25x25mm Cooling Fan

OS Compatibility: Windows 2000/XP/Vista/7/8, Linux and MAC OS 10.4 or above

Dimension:220 x 120 x 68 mm (L x W xH)

1.3 System Requirements

PC Requirements

- Minimum Intel Processor Pentium II/50MHz, 64MB RAM
- Windows 2000 / XP / VISTA/7/8
- Active USB port

MAC Requirements

- Minimum Apple G processor, 64MB RAM
- Mac OS 10.4 and above
- Active USB port

Supported Hard Drives

- One or two 3.5" SATA I/II/III hard drives
- capacity up to 4TB or more
- Hard drives of identical capacities are recommended
- Supports large volumes in excess of 2TB

Note: In order for the computer to access volumes larger than 2TB. Both the hardware and OS need to have the capacity to support large volumes(e.g.: Windows 7/Vista or Mac OS 10.4 and above).

1.4 Package Contents

- 2-bay raid storage enclosure
- Power supply

- USB cable
- Manual

2 RAID Function

What is RAID?

RAID (Redundant Array of Independent Disks) is a set of technology standards for teaming disk drives to improve fault tolerance and performance

Why RAID?

Increased data protection. If in an unfortunate event where a drive fails, the same data is preserved on the mirrored drive.

Intelligent array controllers can apply different types of RAID for different hard disk drives.

Increased overall network system data capacity.

Increased I/O read/write efficiency.

Changing the RAID Mode:

The RAID mode should be set before installing the drives and then first formatting the drives.

1. Make sure the power is off.
2. Set the RAID switch and select your preferred RAID mode. There are 2 mode switches on the inner panel of the product. 4 alternate arrays can be created through these 2 switches. View the diagram below to see the different configuration settings for the RAID switches:

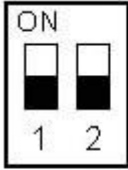

Normal Mode
[OFF/OFF]

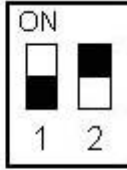

BIG Mode
[OFF/ON]

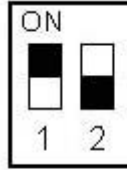

RAID0 Mode
[ON/OFF]

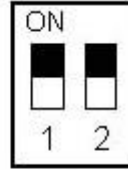

RAID1 Mode
[ON/ON]

3. Install the hard drives and turn on the power.
4. Format the drives.
5. Done

Note: Changing the RAID mode will require you to re-format the drives. Make sure to backup all existing data first!

※ **Normal Mode (Non-Raid):**

Normal mode is the default setting of HDD enclosure, and will not use any RAID mode. In Normal mode, both of the two hard disks inside the enclosure are in an independent operation state, and also will be identified as two separate drives in the system explorer. Users can choose any hard drive for storing files. If one hard drive is damaged, the other hard drives data will not be affected.

※ **JBOD Mode (Spanning):**

In JBOD mode two hard drives will be merged into one. Performance and literacy speed will be the same as a single hard drive. The total capacity of the portable hard drive is equal to the sum of the two hard drives combined. When writing data to the JBOD array, the system will write data to the first disk. When the storage space of the first disk is full the data will start be stored on the second disk. If the data in the first disk is damaged, then all data in the array

will be lost.



※ RAID0 (Striping):

A RAID0 array divides data into two parts respectively in the two hard drives. The theoretical storage speed of the array is twice that of a single drive, and actual capacity equals twice the size of the smallest capacity hard drive (between the two hard drives). The deficit of a RAID0 array is that if any hard drive fails the entire RAID array will not be restored, and the data will be lost.

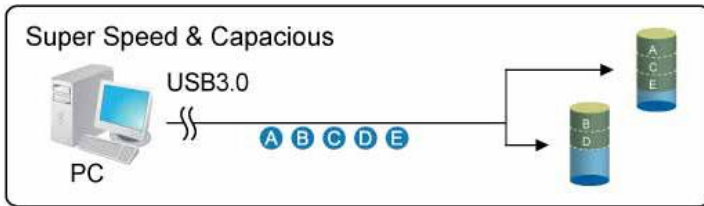

※ RAID1 (Mirroring):

A RAID1 array mirrors data written to the two hard drives equally. The capacity of the array is equal to the smallest capacity drive in the array. Storage speed is same as a single drive. The advantage of RAID1 is that if any hard drive fails the other drive will still carry all data written to the drives. Its deficit is that the maximum capacity of the array is equal to the smallest drive in the array..

Note: For very important material, such as databases or personal data, this is an absolutely safe storage solution.

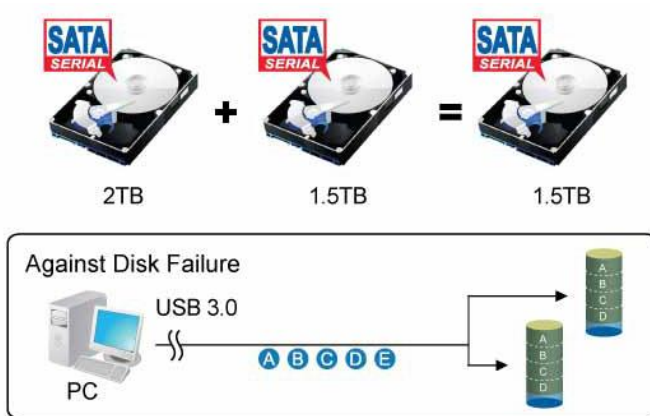

3 System Setup

3.1 Hard Drive Assembly

The drives can be installed at any position, there is no specific order required.

Step 1: Take out the four screws on the back

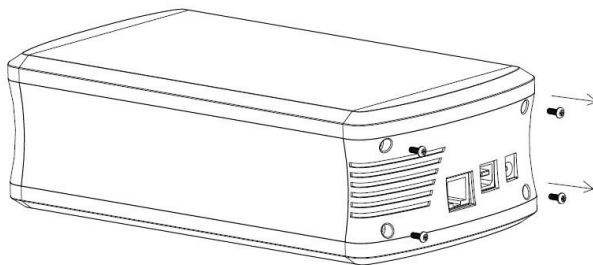

Step 2: Pull out the plastic frame from the aluminum-shell

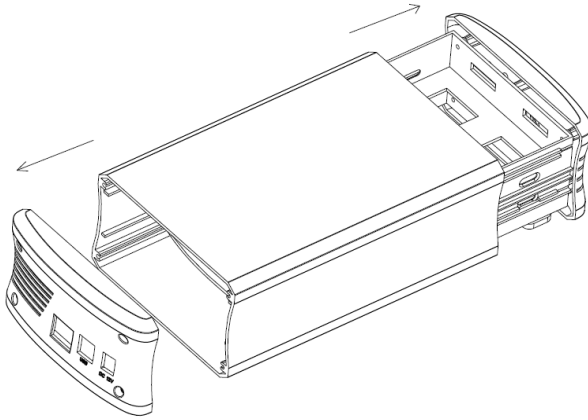

Step 3: Insert the HDDs to the 7+15P SATA connectors on the PCBA. Attach the two HDDs with the included screws

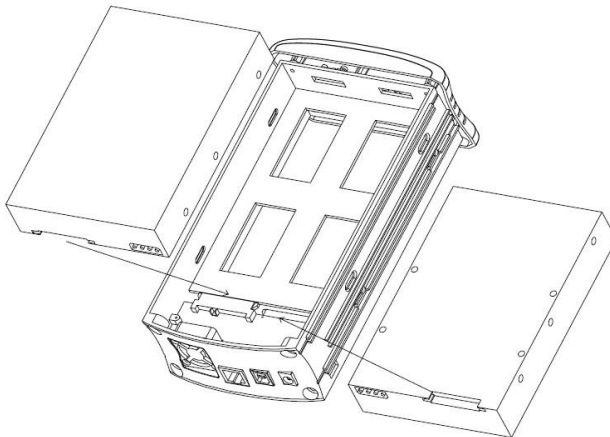

Step 4: Inset the plastic frame into the aluminum housing

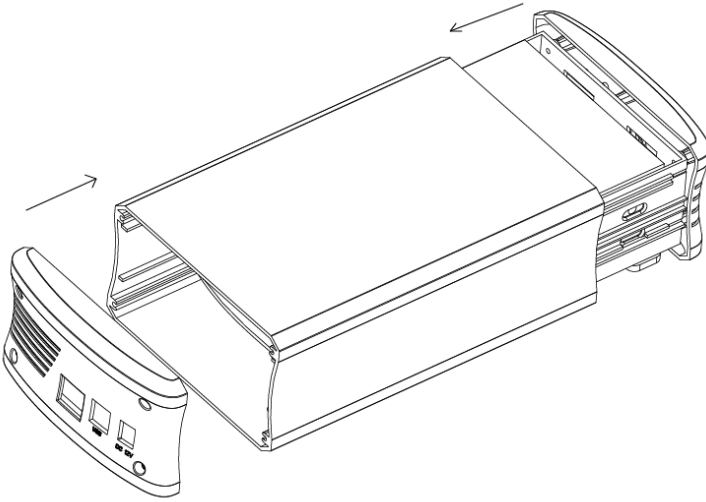

Step 6: Fix the back panel by four screws

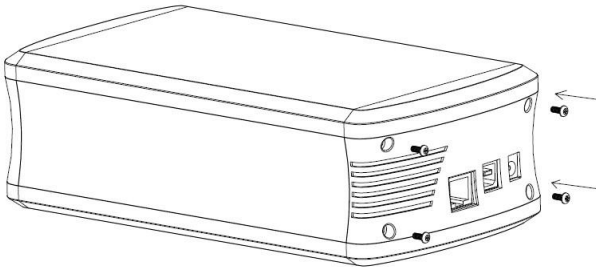

Step 7: HDD Installation completed

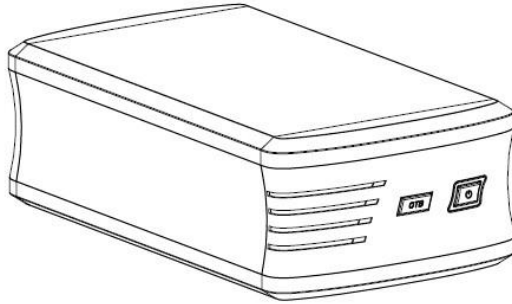

3.2 Connect to computer

1. Connect one end (type B) of the USB cable into the B USB Port of your HDD enclosure.
2. Connect the other end of the USB cable (type A) into any active USB port of the computer.
3. Connect the power supply to the enclosure and power up the enclosure
4. Let the OS search and install the driver automatically.
5. Use the disk management tool(PC) or disk utility(MAC) to create a new partition and format the drives
6. Open “My Computer” to see your external hard drive ready to use.

NOTE:

To enjoy USB 3.0 super speed up to 5Gbps, your computer must be equipped with built-in USB 3.0 ports, or a USB 3.0 host PCI-e card

It is not possible to add more drivers to an existing RAID array without re-formatting it. When adding additional drivers at a later point, they will only be detected after the device has been restarted and the drivers have been re-formatted.

3.3 Files Backup Application

Please consult the help of application software for the backup application installation and operation.

3.4 Replacing Hard Drives

When one drive fails, the HDD LED will display below state:

If HDD1 **Fails**: LED1 off

If HDD2 **Fails**: LED2 off

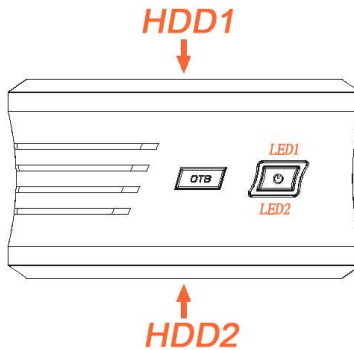

If one drive fails and the RAID mode is set to RAID0 or JBOD, the data will be lost and the system can not be accessed again until the drive have been replace.

1. Check the HDD LED state and replace the faulty drive. The power must turn off when replacing the driver.
2. For RAID 1, the RAID array will be rebuilt automatically. During this process, the HDD LED will flash (HDD R/W). Rebuilding the RAID array will take several hours, depending on the drive capacity. If RAID rebuilding is OK, the HDD LED will keep light normally. If the capacity of the new drive is less than the previous drive, the HDD LED will display as above state. The rebuild process can not be completed.

3. For RAID 0 and JBOD, restart the system and then format the drives again.
4. For Non-RAID (Normal Mode), simply format the new drive.

Note: We recommend not turning off the power during the rebuild process but if the process is interrupted, it will continue rebuilding the data as soon as the power is turned back on.

FAQs:

Q: Can I use external USB hub?

A: Yes, USB hub works in the same way as the computer USB ports

Q: My computer doesn't have USB 3.0 port, Can I use USB 3.0 host adaptor?

A: USB 3.0 host adaptor works in the same way as the built-in USB ports.

Q: What file system should I choose to format my drive?

A: This will depend on how you want to use the drive but in general, we recommend:

Windows XP/VISTA/7/8 → NTFS

Mac OS X → HFS+ (Mac OS Extended)

To use it on both PC and Mac → FAT32 (single file size is limited to 4GB)

Q: How many drives can fail before I loose my data?

A: For RAID 0 and JBOD, any drive failure will result in the data being lost. For RAID 1, more than one drive failure at the same time will mean the data can not be recovered. For Non-RAID, only the data on the defective drive will be lost.