

HP ProLiant ML110 Gen9 Server Maintenance and Service Guide

Abstract

This guide describes identification and maintenance procedures, diagnostic tools, specifications and requirements for hardware components and software. This guide is for an experienced service technician. HP assumes that you are qualified in the servicing of computer equipment, trained in recognizing hazards in products, and are familiar with weight and stability precautions.



Part Number: 790389-001
March 2015
Edition: 1

© Copyright 2015 Hewlett-Packard Development Company, L.P.

The information contained herein is subject to change without notice. The only warranties for HP products and services are set forth in the express warranty statements accompanying such products and services. Nothing herein should be construed as constituting an additional warranty. HP shall not be liable for technical or editorial errors or omissions contained herein.

Linux® is the registered trademark of Linus Torvalds in the U.S. and other countries.

Microsoft® and Windows® are trademarks of the Microsoft group of companies.

microSD is a trademark or a registered trademark of SD-3C in the United States, other countries or both.

Contents

Customer self repair	6
Parts only warranty service	6
Illustrated parts catalog	16
Mechanical components.....	16
System components	19
Removal and replacement procedures	23
Required tools.....	23
Safety considerations.....	23
Preventing electrostatic discharge	23
Symbols on equipment	23
Server warnings and cautions	24
Preparation procedures.....	25
Power down the server	25
Remove the access panel.....	25
Remove the front bezel.....	26
Remove the PCI air baffle	27
Remove the system air baffle.....	28
Non-hot-plug drive cage.....	28
Non-hot-plug drive.....	29
Hot-plug drive blanks	30
Hot-plug drive	31
4-bay LFF hot-plug drive cage	32
8-bay SFF hot-plug drive cage.....	33
Optical drive	34
Fans	36
System fan module (92 x 32 mm)	36
Upgrade fan module (92 x 38 mm)	37
PCI fan module	38
GPU supporting holder	39
FBWC module	41
HP Smart Storage Battery	42
DIMMs.....	43
Heatsink.....	44
Processor	46
System board	51
System battery	58
Dedicated iLO port management module.....	59
Enabling the dedicated iLO management module	60
HP ATX 350-W Power Supply (non-hot-plug).....	61
HP ATX 550-W Power Supply (non-hot-plug).....	61
RPS enablement kit	62
HP redundant power supply input module	65
Redundant power supply blank	67
HP Trusted Platform Module	68

Troubleshooting	69
Troubleshooting resources	69
Diagnostic tools	70
Product QuickSpecs	70
HP iLO	70
Active Health System	71
HP ProLiant Pre-boot Health Summary	71
Integrated Management Log	72
HP UEFI System Utilities	72
Using HP UEFI System Utilities	72
Embedded Diagnostics option	73
Re-entering the server serial number and product ID	73
HP Insight Diagnostics	74
HP Insight Diagnostics survey functionality	74
HP Insight Remote Support	74
USB support	74
External USB functionality	75
HP Smart Storage Administrator	75
Automatic Server Recovery	76
Component identification	77
Front panel components	77
Front panel LEDs and buttons	78
Front panel LED power fault codes	78
Rear panel components	79
Rear panel LEDs	80
System board components	81
System maintenance switch	82
NMI functionality	83
DIMM slot locations	83
Fan locations	84
Drive numbering	84
HP SmartDrive LED definitions	86
Cabling	88
Cabling overview	88
Storage cabling	88
4-bay LFF non-hot-plug drive cabling	88
4-bay LFF hot-plug drive cabling	89
8-bay SFF hot-plug drive cabling	92
FBWC module cabling	95
HP Smart Storage Battery cabling	96
Optical drive cabling	97
Fan cabling	97
Power supply cabling	99
HP ATX 350-W power supply (non-hot-plug)	99
HP ATX 550-W power supply (non-hot-plug)	99
HP 750-W redundant power supply	100
Front I/O cabling	101
Front USB 3.0 cabling	101
Specifications	102
Environmental specifications	102
Server specifications	102

Power supply specifications	103
Hot-plug power supply calculations.....	103
Acronyms and abbreviations.....	104
Documentation feedback	107
Index.....	108

Customer self repair

HP products are designed with many Customer Self Repair (CSR) parts to minimize repair time and allow for greater flexibility in performing defective parts replacement. If during the diagnosis period HP (or HP service providers or service partners) identifies that the repair can be accomplished by the use of a CSR part, HP will ship that part directly to you for replacement. There are two categories of CSR parts:

- **Mandatory**—Parts for which customer self repair is mandatory. If you request HP to replace these parts, you will be charged for the travel and labor costs of this service.
- **Optional**—Parts for which customer self repair is optional. These parts are also designed for customer self repair. If, however, you require that HP replace them for you, there may or may not be additional charges, depending on the type of warranty service designated for your product.

NOTE: Some HP parts are not designed for customer self repair. In order to satisfy the customer warranty, HP requires that an authorized service provider replace the part. These parts are identified as "No" in the Illustrated Parts Catalog.

Based on availability and where geography permits, CSR parts will be shipped for next business day delivery. Same day or four-hour delivery may be offered at an additional charge where geography permits. If assistance is required, you can call the HP Technical Support Center and a technician will help you over the telephone. HP specifies in the materials shipped with a replacement CSR part whether a defective part must be returned to HP. In cases where it is required to return the defective part to HP, you must ship the defective part back to HP within a defined period of time, normally five (5) business days. The defective part must be returned with the associated documentation in the provided shipping material. Failure to return the defective part may result in HP billing you for the replacement. With a customer self repair, HP will pay all shipping and part return costs and determine the courier/carrier to be used.

For more information about HP's Customer Self Repair program, contact your local service provider. For the North American program, refer to the HP website (<http://www.hp.com/go/selfrepair>).

Parts only warranty service

Your HP Limited Warranty may include a parts only warranty service. Under the terms of parts only warranty service, HP will provide replacement parts free of charge.

For parts only warranty service, CSR part replacement is mandatory. If you request HP to replace these parts, you will be charged for the travel and labor costs of this service.

Réparation par le client (CSR)

Les produits HP comportent de nombreuses pièces CSR (Customer Self Repair = réparation par le client) afin de minimiser les délais de réparation et faciliter le remplacement des pièces défectueuses. Si pendant la période de diagnostic, HP (ou ses partenaires ou mainteneurs agréés) détermine que la réparation peut être effectuée à l'aide d'une pièce CSR, HP vous l'envoie directement. Il existe deux catégories de pièces CSR:

Obligatoire - Pièces pour lesquelles la réparation par le client est obligatoire. Si vous demandez à HP de remplacer ces pièces, les coûts de déplacement et main d'œuvre du service vous seront facturés.

Facultatif - Pièces pour lesquelles la réparation par le client est facultative. Ces pièces sont également conçues pour permettre au client d'effectuer lui-même la réparation. Toutefois, si vous demandez à HP de remplacer ces pièces, l'intervention peut ou non vous être facturée, selon le type de garantie applicable à votre produit.

REMARQUE: Certaines pièces HP ne sont pas conçues pour permettre au client d'effectuer lui-même la réparation. Pour que la garantie puisse s'appliquer, HP exige que le remplacement de la pièce soit effectué par un Mainteneur Agréé. Ces pièces sont identifiées par la mention "Non" dans le Catalogue illustré.

Les pièces CSR sont livrées le jour ouvré suivant, dans la limite des stocks disponibles et selon votre situation géographique. Si votre situation géographique le permet et que vous demandez une livraison le jour même ou dans les 4 heures, celle-ci vous sera facturée. Pour bénéficier d'une assistance téléphonique, appelez le Centre d'assistance technique HP. Dans les documents envoyés avec la pièce de rechange CSR, HP précise s'il est nécessaire de lui retourner la pièce défectueuse. Si c'est le cas, vous devez le faire dans le délai indiqué, généralement cinq (5) jours ouvrés. La pièce et sa documentation doivent être retournées dans l'emballage fourni. Si vous ne retournez pas la pièce défectueuse, HP se réserve le droit de vous facturer les coûts de remplacement. Dans le cas d'une pièce CSR, HP supporte l'ensemble des frais d'expédition et de retour, et détermine la société de courses ou le transporteur à utiliser.

Pour plus d'informations sur le programme CSR de HP, contactez votre Mainteneur Agréé local. Pour plus d'informations sur ce programme en Amérique du Nord, consultez le site Web HP (<http://www.hp.com/go/selfrepair>).

Service de garantie "pièces seules"

Votre garantie limitée HP peut inclure un service de garantie "pièces seules". Dans ce cas, les pièces de rechange fournies par HP ne sont pas facturées.

Dans le cadre de ce service, la réparation des pièces CSR par le client est obligatoire. Si vous demandez à HP de remplacer ces pièces, les coûts de déplacement et main d'œuvre du service vous seront facturés.

Riparazione da parte del cliente

Per abbreviare i tempi di riparazione e garantire una maggiore flessibilità nella sostituzione di parti difettose, i prodotti HP sono realizzati con numerosi componenti che possono essere riparati direttamente dal cliente (CSR, Customer Self Repair). Se in fase di diagnostica HP (o un centro di servizi o di assistenza HP) identifica il guasto come riparabile mediante un ricambio CSR, HP lo spedisce direttamente al cliente per la sostituzione. Vi sono due categorie di parti CSR:

Obbligatorie – Parti che devono essere necessariamente riparate dal cliente. Se il cliente ne affida la riparazione ad HP, deve sostenere le spese di spedizione e di manodopera per il servizio.

Opzionali – Parti la cui riparazione da parte del cliente è facultativa. Si tratta comunque di componenti progettati per questo scopo. Se tuttavia il cliente ne richiede la sostituzione ad HP, potrebbe dover sostenere spese aggiuntive a seconda del tipo di garanzia previsto per il prodotto.

NOTA: alcuni componenti HP non sono progettati per la riparazione da parte del cliente. Per rispettare la garanzia, HP richiede che queste parti siano sostituite da un centro di assistenza autorizzato. Tali parti sono identificate da un "No" nel Catalogo illustrato dei componenti.

In base alla disponibilità e alla località geografica, le parti CSR vengono spedite con consegna entro il giorno lavorativo seguente. La consegna nel giorno stesso o entro quattro ore è offerta con un supplemento di costo solo in alcune zone. In caso di necessità si può richiedere l'assistenza telefonica di un addetto del centro di supporto tecnico HP. Nel materiale fornito con una parte di ricambio CSR, HP specifica se il cliente deve restituire dei componenti. Qualora sia richiesta la resa ad HP del componente difettoso, lo si deve spedire ad HP entro un determinato periodo di tempo, generalmente cinque (5) giorni lavorativi. Il componente difettoso deve essere restituito con la documentazione associata nell'imballo di spedizione fornito. La mancata restituzione del componente può comportare la fatturazione del ricambio da parte di HP. Nel caso di riparazione da parte del cliente, HP sostiene tutte le spese di spedizione e resa e sceglie il corriere/vettore da utilizzare.

Per ulteriori informazioni sul programma CSR di HP contattare il centro di assistenza di zona. Per il programma in Nord America fare riferimento al sito Web HP (<http://www.hp.com/go/selfrepair>).

Servizio di garanzia per i soli componenti

La garanzia limitata HP può includere un servizio di garanzia per i soli componenti. Nei termini di garanzia del servizio per i soli componenti, HP fornirà gratuitamente le parti di ricambio.

Per il servizio di garanzia per i soli componenti è obbligatoria la formula CSR che prevede la riparazione da parte del cliente. Se il cliente invece richiede la sostituzione ad HP, dovrà sostenere le spese di spedizione e di manodopera per il servizio.

Customer Self Repair

HP Produkte enthalten viele CSR-Teile (Customer Self Repair), um Reparaturzeiten zu minimieren und höhere Flexibilität beim Austausch defekter Bauteile zu ermöglichen. Wenn HP (oder ein HP Servicepartner) bei der Diagnose feststellt, dass das Produkt mithilfe eines CSR-Teils repariert werden kann, sendet Ihnen HP dieses Bauteil zum Austausch direkt zu. CSR-Teile werden in zwei Kategorien unterteilt:

Zwingend – Teile, für die das Customer Self Repair-Verfahren zwingend vorgegeben ist. Wenn Sie den Austausch dieser Teile von HP vornehmen lassen, werden Ihnen die Anfahrt- und Arbeitskosten für diesen Service berechnet.

Optional – Teile, für die das Customer Self Repair-Verfahren optional ist. Diese Teile sind auch für Customer Self Repair ausgelegt. Wenn Sie jedoch den Austausch dieser Teile von HP vornehmen lassen möchten, können bei diesem Service je nach den für Ihr Produkt vorgesehenen Garantiebedingungen zusätzliche Kosten anfallen.

HINWEIS: Einige Teile sind nicht für Customer Self Repair ausgelegt. Um den Garantieanspruch des Kunden zu erfüllen, muss das Teil von einem HP Servicepartner ersetzt werden. Im illustrierten Teilekatalog sind diese Teile mit „No“ bzw. „Nein“ gekennzeichnet.

CSR-Teile werden abhängig von der Verfügbarkeit und vom Lieferziel am folgenden Geschäftstag geliefert. Für bestimmte Standorte ist eine Lieferung am selben Tag oder innerhalb von vier Stunden gegen einen Aufpreis verfügbar. Wenn Sie Hilfe benötigen, können Sie das HP technische Support Center anrufen und sich von einem Mitarbeiter per Telefon helfen lassen. Den Materialien, die mit einem CSR-Ersatzteil geliefert werden, können Sie entnehmen, ob das defekte Teil an HP zurückgeschickt werden muss. Wenn es erforderlich ist, das defekte Teil an HP zurückzuschicken, müssen Sie dies innerhalb eines vorgegebenen Zeitraums tun, in der Regel innerhalb von fünf (5) Geschäftstagen. Das defekte Teil muss mit der zugehörigen Dokumentation in der Verpackung zurückgeschickt werden, die im Lieferumfang enthalten ist. Wenn Sie das

defekte Teil nicht zurückschicken, kann HP Ihnen das Ersatzteil in Rechnung stellen. Im Falle von Customer Self Repair kommt HP für alle Kosten für die Lieferung und Rücksendung auf und bestimmt den Kurier-/Frachtdienst.

Weitere Informationen über das HP Customer Self Repair Programm erhalten Sie von Ihrem Servicepartner vor Ort. Informationen über das CSR-Programm in Nordamerika finden Sie auf der HP Website unter (<http://www.hp.com/go/selfrepair>).

Parts-only Warranty Service (Garantieservice ausschließlich für Teile)

Ihre HP Garantie umfasst möglicherweise einen Parts-only Warranty Service (Garantieservice ausschließlich für Teile). Gemäß den Bestimmungen des Parts-only Warranty Service stellt HP Ersatzteile kostenlos zur Verfügung.

Für den Parts-only Warranty Service ist das CSR-Verfahren zwingend vorgegeben. Wenn Sie den Austausch dieser Teile von HP vornehmen lassen, werden Ihnen die Anfahrt- und Arbeitskosten für diesen Service berechnet.

Reparaciones del propio cliente

Los productos de HP incluyen muchos componentes que el propio usuario puede reemplazar (*Customer Self Repair*, CSR) para minimizar el tiempo de reparación y ofrecer una mayor flexibilidad a la hora de realizar sustituciones de componentes defectuosos. Si, durante la fase de diagnóstico, HP (o los proveedores o socios de servicio de HP) identifica que una reparación puede llevarse a cabo mediante el uso de un componente CSR, HP le enviará dicho componente directamente para que realice su sustitución. Los componentes CSR se clasifican en dos categorías:

- **Obligatorio:** componentes para los que la reparación por parte del usuario es obligatoria. Si solicita a HP que realice la sustitución de estos componentes, tendrá que hacerse cargo de los gastos de desplazamiento y de mano de obra de dicho servicio.
- **Opcional:** componentes para los que la reparación por parte del usuario es opcional. Estos componentes también están diseñados para que puedan ser reparados por el usuario. Sin embargo, si precisa que HP realice su sustitución, puede o no conllevar costes adicionales, dependiendo del tipo de servicio de garantía correspondiente al producto.

NOTA: Algunos componentes no están diseñados para que puedan ser reparados por el usuario. Para que el usuario haga valer su garantía, HP pone como condición que un proveedor de servicios autorizado realice la sustitución de estos componentes. Dichos componentes se identifican con la palabra "No" en el catálogo ilustrado de componentes.

Según la disponibilidad y la situación geográfica, los componentes CSR se enviarán para que lleguen a su destino al siguiente día laborable. Si la situación geográfica lo permite, se puede solicitar la entrega en el mismo día o en cuatro horas con un coste adicional. Si precisa asistencia técnica, puede llamar al Centro de asistencia técnica de HP y recibirá ayuda telefónica por parte de un técnico. Con el envío de materiales para la sustitución de componentes CSR, HP especificará si los componentes defectuosos deberán devolverse a HP. En aquellos casos en los que sea necesario devolver algún componente a HP, deberá hacerlo en el periodo de tiempo especificado, normalmente cinco días laborables. Los componentes defectuosos deberán devolverse con toda la documentación relacionada y con el embalaje de envío. Si no

enviara el componente defectuoso requerido, HP podrá cobrarle por el de sustitución. En el caso de todas sustituciones que lleve a cabo el cliente, HP se hará cargo de todos los gastos de envío y devolución de componentes y escogerá la empresa de transporte que se utilice para dicho servicio.

Para obtener más información acerca del programa de Reparaciones del propio cliente de HP, póngase en contacto con su proveedor de servicios local. Si está interesado en el programa para Norteamérica, visite la página web de HP siguiente (<http://www.hp.com/go/selfrepair>).

Servicio de garantía exclusivo de componentes

La garantía limitada de HP puede que incluya un servicio de garantía exclusivo de componentes. Según las condiciones de este servicio exclusivo de componentes, HP le facilitará los componentes de repuesto sin cargo adicional alguno.

Para este servicio de garantía exclusivo de componentes, es obligatoria la sustitución de componentes por parte del usuario (CSR). Si solicita a HP que realice la sustitución de estos componentes, tendrá que hacerse cargo de los gastos de desplazamiento y de mano de obra de dicho servicio.

Customer Self Repair

Veel onderdelen in HP producten zijn door de klant zelf te repareren, waardoor de reparatieduur tot een minimum beperkt kan blijven en de flexibiliteit in het vervangen van defecte onderdelen groter is. Deze onderdelen worden CSR-onderdelen (Customer Self Repair) genoemd. Als HP (of een HP Service Partner) bij de diagnose vaststelt dat de reparatie kan worden uitgevoerd met een CSR-onderdeel, verzendt HP dat onderdeel rechtstreeks naar u, zodat u het defecte onderdeel daarmee kunt vervangen. Er zijn twee categorieën CSR-onderdelen:

Verplicht: Onderdelen waarvoor reparatie door de klant verplicht is. Als u HP verzoekt deze onderdelen voor u te vervangen, worden u voor deze service reiskosten en arbeidsloon in rekening gebracht.

Optioneel: Onderdelen waarvoor reparatie door de klant optioneel is. Ook deze onderdelen zijn ontworpen voor reparatie door de klant. Als u echter HP verzoekt deze onderdelen voor u te vervangen, kunnen daarvoor extra kosten in rekening worden gebracht, afhankelijk van het type garantieservice voor het product.

OPMERKING: Sommige HP onderdelen zijn niet ontwikkeld voor reparatie door de klant. In verband met de garantievoorwaarden moet het onderdeel door een geautoriseerde Service Partner worden vervangen. Deze onderdelen worden in de geïllustreerde onderdelencatalogus aangemerkt met "Nee".

Afhankelijk van de leverbaarheid en de locatie worden CSR-onderdelen verzonden voor levering op de eerstvolgende werkdag. Levering op dezelfde dag of binnen vier uur kan tegen meerkosten worden aangeboden, indien dit mogelijk is gezien de locatie. Indien assistentie gewenst is, belt u een HP Service Partner om via de telefoon technische ondersteuning te ontvangen. HP vermeldt in de documentatie bij het vervangende CSR-onderdeel of het defecte onderdeel aan HP moet worden geretourneerd. Als het defecte onderdeel aan HP moet worden teruggezonden, moet u het defecte onderdeel binnen een bepaalde periode, gewoonlijk vijf (5) werkdagen, retourneren aan HP. Het defecte onderdeel moet met de bijbehorende documentatie worden geretourneerd in het meegeleverde verpakkingsmateriaal. Als u het defecte onderdeel niet terugzendt, kan HP u voor het vervangende onderdeel kosten in rekening brengen. Bij reparatie door de klant betaalt HP alle verzendkosten voor het vervangende en geretourneerde onderdeel en kiest HP zelf welke koerier/transportonderneming hiervoor wordt gebruikt.

Neem contact op met een Service Partner voor meer informatie over het Customer Self Repair programma van HP. Informatie over Service Partners vindt u op de HP website (<http://www.hp.com/go/selfrepair>).

Garantieservice "Parts Only"

Het is mogelijk dat de HP garantie alleen de garantieservice "Parts Only" omvat. Volgens de bepalingen van de Parts Only garantieservice zal HP kosteloos vervangende onderdelen ter beschikking stellen.

Voor de Parts Only garantieservice is vervanging door CSR-onderdelen verplicht. Als u HP verzoekt deze onderdelen voor u te vervangen, worden u voor deze service reiskosten en arbeidsloon in rekening gebracht.

Reparo feito pelo cliente

Os produtos da HP são projetados com muitas peças para reparo feito pelo cliente (CSR) de modo a minimizar o tempo de reparo e permitir maior flexibilidade na substituição de peças com defeito. Se, durante o período de diagnóstico, a HP (ou fornecedores/parceiros de serviço da HP) concluir que o reparo pode ser efetuado pelo uso de uma peça CSR, a peça de reposição será enviada diretamente ao cliente. Existem duas categorias de peças CSR:

Obrigatória – Peças cujo reparo feito pelo cliente é obrigatório. Se desejar que a HP substitua essas peças, serão cobradas as despesas de transporte e mão-de-obra do serviço.

Opcional – Peças cujo reparo feito pelo cliente é opcional. Essas peças também são projetadas para o reparo feito pelo cliente. No entanto, se desejar que a HP as substitua, pode haver ou não a cobrança de taxa adicional, dependendo do tipo de serviço de garantia destinado ao produto.

OBSERVAÇÃO: Algumas peças da HP não são projetadas para o reparo feito pelo cliente. A fim de cumprir a garantia do cliente, a HP exige que um técnico autorizado substitua a peça. Essas peças estão identificadas com a marca "No" (Não), no catálogo de peças ilustrado.

Conforme a disponibilidade e o local geográfico, as peças CSR serão enviadas no primeiro dia útil após o pedido. Onde as condições geográficas permitirem, a entrega no mesmo dia ou em quatro horas pode ser feita mediante uma taxa adicional. Se precisar de auxílio, entre em contato com o Centro de suporte técnico da HP para que um técnico o ajude por telefone. A HP especifica nos materiais fornecidos com a peça CSR de reposição se a peça com defeito deve ser devolvida à HP. Nos casos em que isso for necessário, é preciso enviar a peça com defeito à HP dentro do período determinado, normalmente cinco (5) dias úteis. A peça com defeito deve ser enviada com a documentação correspondente no material de transporte fornecido. Caso não o faça, a HP poderá cobrar a reposição. Para as peças de reparo feito pelo cliente, a HP paga todas as despesas de transporte e de devolução da peça e determina a transportadora/serviço postal a ser utilizado.

Para obter mais informações sobre o programa de reparo feito pelo cliente da HP, entre em contato com o fornecedor de serviços local. Para o programa norte-americano, visite o site da HP (<http://www.hp.com/go/selfrepair>).

Serviço de garantia apenas para peças

A garantia limitada da HP pode incluir um serviço de garantia apenas para peças. Segundo os termos do serviço de garantia apenas para peças, a HP fornece as peças de reposição sem cobrar nenhuma taxa.

No caso desse serviço, a substituição de peças CSR é obrigatória. Se desejar que a HP substitua essas peças, serão cobradas as despesas de transporte e mão-de-obra do serviço.

カスタマーセルフリペア

修理時間を短縮し、故障部品の交換における高い柔軟性を確保するために、HP製品には多数のCSR部品があります。診断の際に、CSR部品を使用すれば修理ができるとHP（HPまたはHP正規保守代理店）が判断した場合、HPはその部品を直接、お客様に発送し、お客様に交換していただきます。CSR部品には以下の2通りがあります。

- **必須** - カスタマーセルフリペアが必須の部品。当該部品について、もしもお客様がHPに交換作業を依頼される場合には、その修理サービスに関する交通費および人件費がお客様に請求されます。
- **任意** - カスタマーセルフリペアが任意である部品。この部品もカスタマーセルフリペア用です。当該部品について、もしもお客様がHPに交換作業を依頼される場合には、お買い上げの製品に適用される保証サービス内容の範囲内においては、別途費用を負担していただくことなく保証サービスを受けることができます。

注： HP製品の一部の部品は、カスタマーセルフリペア用ではありません。製品の保証を継続するためには、HPまたはHP正規保守代理店による交換作業が必須となります。部品カタログには、当該部品がカスタマーセルフリペア除外品である旨が記載されています。

部品供給が可能な場合、地域によっては、CSR部品を翌営業日に届くように発送します。また、地域によっては、追加費用を負担いただくことにより同日または4時間以内に届くように発送することも可能な場合があります。サポートが必要なときは、HPの修理受付窓口へ電話していただければ、技術者が電話でアドバイスします。交換用のCSR部品または同梱物には、故障部品をHPに返送する必要があるかどうかが表示されています。故障部品をHPに返送する必要がある場合は、指定期限内（通常は5営業日以内）に故障部品をHPに返送してください。故障部品を返送する場合は、届いた時の梱包箱に関連書類とともに入れてください。故障部品を返送しない場合、HPから部品費用が請求されます。カスタマーセルフリペアの際には、HPは送料および部品返送費を全額負担し、使用する宅配便会社や運送会社を指定します。

部品のみ保証サービス

HP保証サービスには、部品のみ保証サービスが適用される場合があります。このサービスでは、交換部品は無償で提供されます。

部品のみ保証サービスにおいては、CSR部品をお客様により交換作業していただくことが必須となります。当該部品について、もしもお客様がHPに交換作業を依頼される場合には、その修理サービスに関する交通費および人件費はお客様の負担となります。

客户自行维修

HP 产品提供许多客户自行维修 (CSR) 部件，以尽可能缩短维修时间和在更换缺陷部件方面提供更大的灵活性。如果在诊断期间 HP（或 HP 服务提供商或服务合作伙伴）确定可以通过使用 CSR 部件完成维修，HP 将直接把该部件发送给您进行更换。有两类 CSR 部件：

- **强制性的** — 要求客户必须自行维修的部件。如果您请求 HP 更换这些部件，则必须为该服务支付差旅费和人工费用。
- **可选的** — 客户可以选择是否自行维修的部件。这些部件也是为客户自行维修设计的。不过，如果您要求 HP 为您更换这些部件，则根据为您的产品指定的保修服务类型，HP 可能收取或不再收取任何附加费用。

注：某些 HP 部件的设计并未考虑客户自行维修。为了满足客户保修的需要，HP 要求授权服务提供商更换相关部件。这些部件在部件图解目录中标记为“否”。

CSR 部件将在下一个工作日发运（取决于备货情况和允许的地理范围）。在允许的地理范围内，可在当天或四小时内发运，但要收取额外费用。如果需要帮助，您可以致电 HP 技术支持中心，将会有技术人员通过电话为您提供帮助。HP 会在随更换的 CSR 部件发运的材料中指明是否必须将有缺陷的部件返还给 HP。如果要求您将有缺陷的部件返还给 HP，那么您必须在规定期限内（通常是五 (5) 个工作日）将缺陷部件发给 HP。有缺陷的部件必须随所提供的发运材料中的相关文件一起返还。如果未能送还缺陷的部件，HP 可能会要求您支付更换费用。客户自行维修时，HP 将承担所有相关运输和部件返回费用，并指定快递商/承运商。

有关 HP 客户自行维修计划的详细信息，请与您当地的服务提供商联系。有关北美地区的计划，请访问 HP 网站 (<http://www.hp.com/go/selfrepair>)。

仅部件保修服务

您的 HP 有限保修服务可能涉及仅部件保修服务。根据仅部件保修服务条款的规定，HP 将免费提供更换的部件。

仅部件保修服务要求进行 CSR 部件更换。如果您请求 HP 更换这些部件，则必须为该服务支付差旅费和人工费用。

客戶自行維修

HP 產品設計了許多「客戶自行維修」(CSR) 的零件以減少維修時間，並且使得更換瑕疵零件時能有更大的彈性。如果在診斷期間 HP (或 HP 服務供應商或維修夥伴) 辨認出此項維修工作可以藉由使用 CSR 零件來完成，則 HP 將直接寄送該零件給您作更換。CSR 零件分為兩種類別：

- **強制的** — 客戶自行維修所使用的零件是強制性的。如果您要求 HP 更換這些零件，HP 將會向您收取此服務所需的外出費用與勞動成本。
- **選購的** — 客戶自行維修所使用的零件是選購的。這些零件也設計用於客戶自行維修之用。不過，如果您要求 HP 為您更換，則可能需要也可能不需要負擔額外的費用，端視針對此產品指定的保固服務類型而定。

備註：某些 HP 零件沒有消費者可自行維修的設計。為符合客戶保固，HP 需要授權的服務供應商更換零件。這些零件在圖示的零件目錄中，被標示為「否」。

基於材料取得及環境允許的情況下，CSR 零件將於下一個工作日以快遞寄送。在環境的允許下當天或四小時內送達，則可能需要額外的費用。若您需要協助，可致電「HP 技術支援中心」，會有一位技術人員透過電話來協助您。不論損壞的零件是否必須退回，HP 皆會在與 CSR 替換零件一起運送的材料中註明。若要將損壞的零件退回 HP，您必須在指定的一段時間內（通常為五 (5) 個工作天），將損壞的零件寄回 HP。損壞的零件必須與寄送資料中隨附的相關技術文件一併退還。如果無法退還損壞的零件，HP 可能要向您收取替換費用。針對客戶自行維修情形，HP 將負責所有運費及零件退還費用並指定使用何家快遞/貨運公司。

如需 HP 的「客戶自行維修」方案詳細資訊，請連絡您當地的服務供應商。至於北美方案，請參閱 HP 網站 (<http://www.hp.com/go/selfrepair>)。

僅限零件的保固服務

您的「HP 有限保固」可能包含僅限零件的保固服務。在僅限零件的保固服務情況下，HP 將免費提供替換零件。

針對僅限零件的保固服務，CSR 零件替換是強制性的。如果您要求 HP 更換這些零件，HP 將會向您收取此服務所需的外出費用與勞動成本。

고객 셀프 수리

HP 제품은 수리 시간을 최소화하고 결함이 있는 부품 교체 시 더욱 융통성을 발휘할 수 있도록 하기 위해 고객 셀프 수리(CSR) 부품을 다량 사용하여 설계되었습니다. 진단 기간 동안 HP(또는 HP 서비스 공급업체 또는 서비스 협력업체)에서 CSR 부품을 사용하여 수리가 가능하다고 판단되면 HP는 해당 부품을 바로 사용자에게 보내어 사용자가 교체할 수 있도록 합니다. CSR 부품에는 두 가지 종류가 있습니다.

- **고객 셀프 수리가 의무 사항인 필수 부품.** 사용자가 HP에 이 부품의 교체를 요청할 경우 이 서비스에 대한 출장비 및 작업비가 청구됩니다.
- **고객 셀프 수리가 선택 사항인 부품.** 이 부품들도 고객 셀프 수리가 가능하도록 설계되었습니다. 하지만 사용자가 HP에 이 부품의 교체를 요청할 경우 사용자가 구입한 제품에 해당하는 보증 서비스 유형에 따라 추가 비용 없이 교체가 가능할 수 있습니다.

참고: 일부 HP 부품은 고객 셀프 수리가 불가능하도록 설계되었습니다. HP는 만족스러운 고객 보증을 위해 공인 서비스 제공업체를 통해 부품을 교체하도록 하고 있습니다. 이러한 부품들은 Illustrated Parts Catalog에 "No"라고 표시되어 있습니다.

CSR 부품은 재고 상태와 지리적 조건이 허용하는 경우 다음 영업일 납품이 가능하도록 배송이 이루어집니다. 지리적 조건이 허용하는 경우 추가 비용이 청구되는 조건으로 당일 또는 4시간 배송이 가능할 수도 있습니다. 도움이 필요하시면 HP 기술 지원 센터로 전화하십시오. 전문 기술자가 전화로 도움을 줄 것입니다. HP는 결함이 발생한 부품을 HP로 반환해야 하는지 여부를 CSR 교체 부품과 함께 배송된 자료에 지정합니다. 결함이 발생한 부품을 HP로 반환해야 하는 경우에는 지정된 기간 내(통상 영업일 기준 5일)에 HP로 반환해야 합니다. 이 때 결함이 발생한 부품은 제공된 포장 재료에 넣어 관련 설명서와 함께 반환해야 합니다. 결함이 발생한 부품을 반환하지 않는 경우 HP가 교체 부품에 대해 비용을 청구할 수 있습니다. 고객 셀프 수리의 경우, HP는 모든 운송 및 부품 반환 비용을 부담하며 이용할 운송업체 및 택배 서비스를 결정합니다.

HP 고객 셀프 수리 프로그램에 대한 자세한 내용은 가까운 서비스 제공업체에 문의하십시오. 북미 지역의 프로그램에 대해서는 HP 웹 사이트(<http://www.hp.com/go/selfrepair>)를 참조하십시오.

부품 제공 보증 서비스

HP 제한 보증에는 부품 제공 보증 서비스가 포함될 수 있습니다. 이러한 경우 HP는 부품 제공 보증 서비스의 조건에 따라 교체 부품만을 무료로 제공합니다.

부품 제공 보증 서비스 제공 시 CSR 부품 교체는 의무 사항입니다. 사용자가 HP에 이 부품의 교체를 요청할 경우 이 서비스에 대한 출장비 및 작업비가 청구됩니다.

Illustrated parts catalog

Mechanical components

HP continually improves and changes product parts. For complete and current supported parts information, see the HP PartSurfer website (<http://partsurfer.hp.com>).

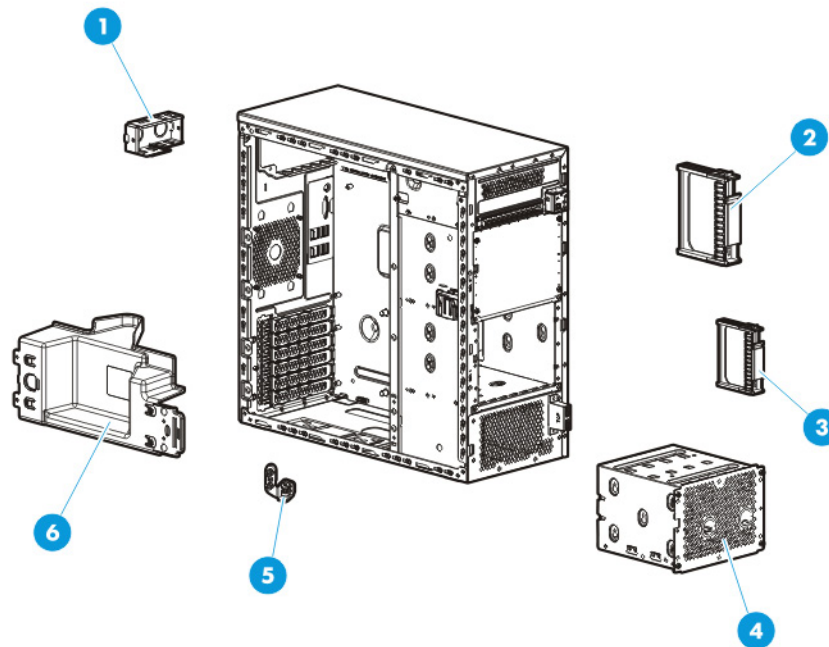

Item	Description	Spare part number	Customer self repair (on page 6)
1	Redundant power supply blank	698883-001	Mandatory ¹
2	LFF hard drive blank	667279-001	Mandatory ¹
3	SFF hard drive blank	667276-001	Mandatory ¹
4	4-bay LFF non-hot-plug drive cage	792353-001	Mandatory ¹
5	GPU supporting holder	791711-001	Mandatory ¹
6	PCI air baffle	791709-001	Mandatory ¹

¹Mandatory—Parts for which customer self repair is mandatory. If you request HP to replace these parts, you will be charged for the travel and labor costs of this service.

²Optional—Parts for which customer self repair is optional. These parts are also designed for customer self repair. If, however, you require that HP replace them for you, there may or may not be additional charges, depending on the type of warranty service designated for your product.

³No—Some HP parts are not designed for customer self repair. In order to satisfy the customer warranty, HP requires that an authorized service provider replace the part. These parts are identified as "No" in the Illustrated Parts Catalog.

¹Mandatory: Obligatoire—Pièces pour lesquelles la réparation par le client est obligatoire. Si vous demandez à HP de remplacer ces pièces, les coûts de déplacement et main d'œuvre du service vous seront facturés.

²Optional: Facultatif—Pièces pour lesquelles la réparation par le client est facultative. Ces pièces sont également conçues pour permettre au client d'effectuer lui-même la réparation. Toutefois, si vous demandez à HP de remplacer ces pièces, l'intervention peut ou non vous être facturée, selon le type de garantie applicable à votre produit.

³No: Non—Certaines pièces HP ne sont pas conçues pour permettre au client d'effectuer lui-même la réparation. Pour que la garantie puisse s'appliquer, HP exige que le remplacement de la pièce soit effectué par un Mainteneur Agréé. Ces pièces sont identifiées par la mention "Non" dans le Catalogue illustré.

¹Mandatory: Obbligatorie—Parti che devono essere necessariamente riparate dal cliente. Se il cliente ne affida la riparazione ad HP, deve sostenere le spese di spedizione e di manodopera per il servizio.

²Optional: Opzionali—Parti la cui riparazione da parte del cliente è facoltativa. Si tratta comunque di componenti progettati per questo scopo. Se tuttavia il cliente ne richiede la sostituzione ad HP, potrebbe dover sostenere spese aggiuntive a seconda del tipo di garanzia previsto per il prodotto.

³No: Non CSR—Alcuni componenti HP non sono progettati per la riparazione da parte del cliente. Per rispettare la garanzia, HP richiede che queste parti siano sostituite da un centro di assistenza autorizzato. Tali parti sono identificate da un "No" nel Catalogo illustrato dei componenti.

¹Mandatory: Zwingend—Teile, die im Rahmen des Customer Self Repair Programms ersetzt werden müssen. Wenn Sie diese Teile von HP ersetzen lassen, werden Ihnen die Versand- und Arbeitskosten für diesen Service berechnet.

²Optional: Optional—Teile, für die das Customer Self Repair-Verfahren optional ist. Diese Teile sind auch für Customer Self Repair ausgelegt. Wenn Sie jedoch den Austausch dieser Teile von HP vornehmen lassen möchten, können bei diesem Service je nach den für Ihr Produkt vorgesehenen Garantiebedingungen zusätzliche Kosten anfallen.

³No: Kein—Einige Teile sind nicht für Customer Self Repair ausgelegt. Um den Garantieanspruch des Kunden zu erfüllen, muss das Teil von einem HP Servicepartner ersetzt werden. Im illustrierten Teilekatalog sind diese Teile mit „No“ bzw. „Nein“ gekennzeichnet.

¹Mandatory: Obligatorio—componentes para los que la reparación por parte del usuario es obligatoria. Si solicita a HP que realice la sustitución de estos componentes, tendrá que hacerse cargo de los gastos de desplazamiento y de mano de obra de dicho servicio.

²Optional: Opcional— componentes para los que la reparación por parte del usuario es opcional. Estos componentes también están diseñados para que puedan ser reparados por el usuario. Sin embargo, si precisa que HP realice su sustitución, puede o no conllevar costes adicionales, dependiendo del tipo de servicio de garantía correspondiente al producto.

³No: No—Algunos componentes no están diseñados para que puedan ser reparados por el usuario. Para que el usuario haga valer su garantía, HP pone como condición que un proveedor de servicios autorizado realice la sustitución de estos componentes. Dichos componentes se identifican con la palabra "No" en el catálogo ilustrado de componentes.

¹Mandatory: Verplicht—Onderdelen waarvoor Customer Self Repair verplicht is. Als u HP verzoekt deze onderdelen te vervangen, komen de reiskosten en het arbeidsloon voor uw rekening.

²Optional: Optioneel—Onderdelen waarvoor reparatie door de klant optioneel is. Ook deze onderdelen zijn ontworpen voor reparatie door de klant. Als u echter HP verzoekt deze onderdelen voor u te vervangen, kunnen daarvoor extra kosten in rekening worden gebracht, afhankelijk van het type garantieservice voor het product.

³No: Nee—Sommige HP onderdelen zijn niet ontwikkeld voor reparatie door de klant. In verband met de garantievooraardelen moet het onderdeel door een geautoriseerde Service Partner worden vervangen. Deze onderdelen worden in de geïllustreerde onderdelencatalogus aangemerkt met "Nee".

¹Mandatory: Obrigatória—Peças cujo reparo feito pelo cliente é obrigatório. Se desejar que a HP substitua essas peças, serão cobradas as despesas de transporte e mão-de-obra do serviço.

²Optional: Opcional—Peças cujo reparo feito pelo cliente é opcional. Essas peças também são projetadas para o reparo feito pelo cliente. No entanto, se desejar que a HP as substitua, pode haver ou não a cobrança de taxa adicional, dependendo do tipo de serviço de garantia destinado ao produto.

³No: Nenhuma—Algumas peças da HP não são projetadas para o reparo feito pelo cliente. A fim de cumprir a garantia do cliente, a HP exige que um técnico autorizado substitua a peça. Essas peças estão identificadas com a marca "No" (Não), no catálogo de peças ilustrado.

¹Mandatory : 必須 - 顧客自己修理が必須の部品。当該部品について、もしもお客様がHPに交換作業を依頼される場合には、その修理サービスに関する交通費および人件費がお客様に請求されます。

²Optional : 任意 - 顧客自己修理が任意である部品。この部品も顧客自己修理用です。当該部品について、もしもお客様がHPに交換作業を依頼される場合には、お買い上げの製品に適用される保証サービス内容の範囲内においては、費用を負担していただくことなく保証サービスを受けることができます。

³No : 除外 - HP製品の一部の部品は、顧客自己修理用ではありません。製品の保証を継続するためには、HPまたはHP正規保守代理店による交換作業が必須となります。部品カタログには、当該部品が顧客自己修理除外品である旨が記載されています。

¹Mandatory: 强制性的 — 要求客户必须自行维修的部件。如果您请求 HP 更换这些部件，则必须为该服务支付差旅费和人工费用。

²Optional: 可选的 — 客户可以选择是否自行维修的部件。这些部件也是为客户自行维修设计的。不过，如果您要求 HP 为您更换这些部件，则根据您的产品指定的保修服务类型，HP 可能收取或不再收取任何附加费用。

³No: 否 — 某些 HP 部件的设计并未考虑客户自行维修。为了满足客户保修的需要，HP 要求授权服务提供商更换相关部件。这些部件在部件图解目录中标记为“否”。

¹Mandatory: 強制的 — 客戶自行維修所使用的零件是強制性的。如果您要求 HP 更換這些零件，HP 將會向您收取此服務所需的外出費用與勞動成本。

²Optional: 選購的 — 客戶自行維修所使用的零件是選購的。這些零件也設計用於客戶自行維修之用。不過，如果您要求 HP 為您更換，則可能需要也可能不需要負擔額外的費用，端視針對此產品指定的保固服務類型而定。

³No: 否 — 某些 HP 零件沒有消費者可自行維修的設計。為符合客戶保固，HP 需要授權的服務供應商更換零件。這些零件在圖示的零件目錄中，被標示為「否」。

¹ Mandatory: 필수 — 고객 셀프 수리가 의무 사항인 필수 부품. 사용자가 HP에 이 부품의 교체를 요청할 경우 이 서비스에 대한 출장비 및 작업비가 청구됩니다.

² Optional: 옵션 — 고객 셀프 수리가 선택 사항인 부품. 이 부품들도 고객 셀프 수리가 가능하도록 설계되었습니다. 하지만 사용자가 HP에 이 부품의 교체를 요청할 경우 사용자가 구입한 제품에 해당하는 보증 서비스 유형에 따라 추가 비용 없이 교체가 가능할 수 있습니다.

³ No: No — 고객 셀프 수리가 불가능하도록 설계된 HP 부품. 이 부품들은 고객 셀프 수리가 불가능하도록 설계되었습니다. HP는 고객 보증을 만족시키기 위해 공인 서비스 제공업체를 통해 부품을 교체하도록 하고 있습니다.

System components

HP continually improves and changes product parts. For complete and current supported parts information, see the HP PartSurfer website (<http://partsurfer.hp.com>).

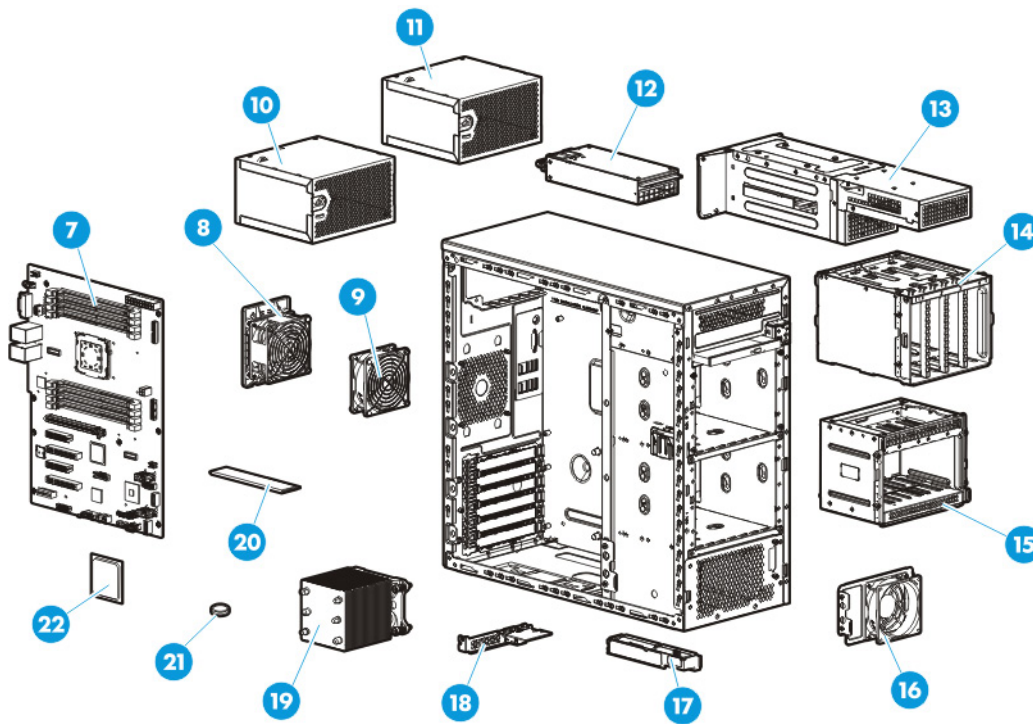

Item	Description	Spare part number	Customer self repair (on page 6)
7	System board assembly (includes alcohol pad and thermal compound)	791704-001	Optional ²
8	Upgrade fan module (92x38 mm)	791717-001	Mandatory ¹
9	System fan module (92x32 mm)	791708-001	Mandatory ¹
10	HP ATX 350-W Power Supply (non-hot-plug)	791705-001	Mandatory ¹
11	HP ATX 550-W Power Supply (non-hot-plug)	791706-001	Mandatory ¹
12	HP 750-W Common Slot Gold Hot Plug Power Supply	511778-001	Mandatory ¹
13	RPS enablement kit	791712-001	Optional ²
14	4-bay LFF hot-plug drive cage	792351-001	Optional ²
15	8-bay SFF hot-plug drive cage	792352-001	Optional ²
16	PCI fan module	791710-001	Mandatory ¹
17	HP Smart Storage Battery	750450-001	Mandatory ¹
18	Dedicated iLO module	792354-001	Optional ²
19	Heatsink	780977-001	Optional ²
20	DIMMs	—	—
	a) 4 GB, single rank 1Rx8 PC4-2133P-R*	804842-001	Mandatory ¹
	b) 4 GB, single-rank 1Rx8 PC4-2133R-15	774169-001	Mandatory ¹
	c) 8 GB, single rank 1Rx4 PC4-2133P-R	804843-001	Mandatory ¹
	d) 8 GB, single-rank 1Rx4 PC4-2133R-15*	774170-001	Mandatory ¹

	e) 8 GB, dual-rank 2Rx8 PC4-2133R-15*	774171-001	Mandatory ¹
	f) 16 GB, dual-rank 2Rx4 PC4-2133R-15*	774172-001	Mandatory ¹
	g) 16 GB, dual-rank 2Rx4 PC4-2133L-15*	774173-001	Mandatory ¹
	h) 32 GB, dual-rank 2Rx4 PC4-2133R-15*	774175-001	Mandatory ¹
21	System battery	234556-001	Mandatory ¹
22	Processors (include alcohol pad and thermal compound)	—	—
	a) 1.60-GHz Intel Xeon E5-2603 v3, 6C, 85 W	762441-001	Optional ²
	b) 1.80-GHz Intel Xeon E5-2630L v3, 8C, 50 W*	762459-001	Optional ²
	c) 1.90-GHz Intel Xeon E5-2609 v3, 6C, 85 W*	762443-001	Optional ²
	d) 2.40-GHz Intel Xeon E5-2620 v3, 6C, 85 W*	762445-001	Optional ²
	e) 2.40-GHz Intel Xeon E5-2630 v3, 8C, 85 W*	762446-001	Optional ²
	f) 2.60-GHz Intel Xeon E5-2640 v3, 8C, 90 W*	762447-001	Optional ²
	g) 2.60-GHz Intel Xeon E5-2660 v3, 10C, 105 W*	762449-001	Optional ²
	h) 2.80-GHz Intel Xeon E5-1603 v3 4C, 140 W* with jacket	799505-001	Optional ²
	i) 3.0-GHz Intel Xeon E5-2623 v3, 4C, 105 W*	780762-001	Optional ²
	j) 3.50-GHz Intel Xeon E5-1620 v3, 4C, 140 W* with jacket	799506-001	Optional ²
23	Misc cable kit*	791718-001	Mandatory ¹
	a) Front panel LED cable*	—	—
	b) Front USB cable*	—	—
	c) Hard drive power good cable*	—	—
24	Data cable kit*	791719-001	Mandatory ¹
	a) 6G, 490 mm, Mini-SAS cable*	—	—
	b) 12G, 540 mm, Mini-SAS cable*	—	—
	c) 540 mm Mini-SAS Y cable*	—	—
	d) 300 mm SATA to Mini-SAS cable*	—	—

* Not shown

¹Mandatory—Parts for which customer self repair is mandatory. If you request HP to replace these parts, you will be charged for the travel and labor costs of this service.

²Optional—Parts for which customer self repair is optional. These parts are also designed for customer self repair. If, however, you require that HP replace them for you, there may or may not be additional charges, depending on the type of warranty service designated for your product.

³No—Some HP parts are not designed for customer self repair. In order to satisfy the customer warranty, HP requires that an authorized service provider replace the part. These parts are identified as "No" in the Illustrated Parts Catalog.

¹Mandatory: Obligatoire—Pièces pour lesquelles la réparation par le client est obligatoire. Si vous demandez à HP de remplacer ces pièces, les coûts de déplacement et main d'œuvre du service vous seront facturés.

²Optional: Facultatif—Pièces pour lesquelles la réparation par le client est facultative. Ces pièces sont également conçues pour permettre au client d'effectuer lui-même la réparation. Toutefois, si vous demandez à HP de remplacer ces pièces, l'intervention peut ou non vous être facturée, selon le type de garantie applicable à votre produit.

³No: Non—Certaines pièces HP ne sont pas conçues pour permettre au client d'effectuer lui-même la réparation. Pour que la garantie puisse s'appliquer, HP exige que le remplacement de la pièce soit effectué par un Mainteneur Agréé. Ces pièces sont identifiées par la mention "Non" dans le Catalogue illustré.

¹Mandatory: Obbligatorie—Parti che devono essere necessariamente riparate dal cliente. Se il cliente ne affida la riparazione ad HP, deve sostenere le spese di spedizione e di manodopera per il servizio.

²Optional: Opzionali—Parti la cui riparazione da parte del cliente è facoltativa. Si tratta comunque di componenti progettati per questo scopo. Se tuttavia il cliente ne richiede la sostituzione ad HP, potrebbe dover sostenere spese aggiuntive a seconda del tipo di garanzia previsto per il prodotto.

³No: Non CSR—Alcuni componenti HP non sono progettati per la riparazione da parte del cliente. Per rispettare la garanzia, HP richiede che queste parti siano sostituite da un centro di assistenza autorizzato. Tali parti sono identificate da un "No" nel Catalogo illustrato dei componenti.

¹Mandatory: Zwingend—Teile, die im Rahmen des Customer Self Repair Programms ersetzt werden müssen. Wenn Sie diese Teile von HP ersetzen lassen, werden Ihnen die Versand- und Arbeitskosten für diesen Service berechnet.

²Optional: Optional—Teile, für die das Customer Self Repair-Verfahren optional ist. Diese Teile sind auch für Customer Self Repair ausgelegt. Wenn Sie jedoch den Austausch dieser Teile von HP vornehmen lassen möchten, können bei diesem Service je nach den für Ihr Produkt vorgesehenen Garantiebedingungen zusätzliche Kosten anfallen.

³No: Kein—Einige Teile sind nicht für Customer Self Repair ausgelegt. Um den Garantieanspruch des Kunden zu erfüllen, muss das Teil von einem HP Servicepartner ersetzt werden. Im illustrierten Teilekatalog sind diese Teile mit „No“ bzw. „Nein“ gekennzeichnet.

¹Mandatory: Obligatorio—componentes para los que la reparación por parte del usuario es obligatoria. Si solicita a HP que realice la sustitución de estos componentes, tendrá que hacerse cargo de los gastos de desplazamiento y de mano de obra de dicho servicio.

²Optional: Opcional— componentes para los que la reparación por parte del usuario es opcional. Estos componentes también están diseñados para que puedan ser reparados por el usuario. Sin embargo, si precisa que HP realice su sustitución, puede o no conllevar costes adicionales, dependiendo del tipo de servicio de garantía correspondiente al producto.

³No: No—Algunos componentes no están diseñados para que puedan ser reparados por el usuario. Para que el usuario haga valer su garantía, HP pone como condición que un proveedor de servicios autorizado realice la sustitución de estos componentes. Dichos componentes se identifican con la palabra "No" en el catálogo ilustrado de componentes.

¹Mandatory: Verplicht—Onderdelen waarvoor Customer Self Repair verplicht is. Als u HP verzoekt deze onderdelen te vervangen, komen de reiskosten en het arbeidsloon voor uw rekening.

²Optional: Optioneel—Onderdelen waarvoor reparatie door de klant optioneel is. Ook deze onderdelen zijn ontworpen voor reparatie door de klant. Als u echter HP verzoekt deze onderdelen voor u te vervangen, kunnen daarvoor extra kosten in rekening worden gebracht, afhankelijk van het type garantieservice voor het product.

³No: Nee—Sommige HP onderdelen zijn niet ontwikkeld voor reparatie door de klant. In verband met de garantievoorwaarden moet het onderdeel door een geautoriseerde Service Partner worden vervangen. Deze onderdelen worden in de geïllustreerde onderdelencatalogus aangemerkt met "Nee".

¹Mandatory: Obrigatória—Peças cujo reparo feito pelo cliente é obrigatório. Se desejar que a HP substitua essas peças, serão cobradas as despesas de transporte e mão-de-obra do serviço.

²Optional: Opcional—Peças cujo reparo feito pelo cliente é opcional. Essas peças também são projetadas para o reparo feito pelo cliente. No entanto, se desejar que a HP as substitua, pode haver ou não a cobrança de taxa adicional, dependendo do tipo de serviço de garantia destinado ao produto.

³No: Nenhuma—Algumas peças da HP não são projetadas para o reparo feito pelo cliente. A fim de cumprir a garantia do cliente, a HP exige que um técnico autorizado substitua a peça. Essas peças estão identificadas com a marca "No" (Não), no catálogo de peças ilustrado.

¹Mandatory : 必須 - 顧客自己修理が必須の部品。当該部品について、もしもお客様がHPに交換作業を依頼される場合には、その修理サービスに関する交通費および人件費がお客様に請求されます。

²Optional : 任意 - 顧客自己修理が任意である部品。この部品も顧客自己修理用です。当該部品について、もしもお客様がHPに交換作業を依頼される場合には、お買い上げの製品に適用される保証サービス内容の範囲内においては、費用を負担していただくことなく保証サービスを受けることができます。

³No : 除外 - HP製品の一部の部品は、顧客自己修理用ではありません。製品の保証を継続するためには、HPまたはHP正規保守代理店による交換作業が必須となります。部品カタログには、当該部品が顧客自己修理除外品である旨が記載されています。

¹Mandatory: 强制性的 — 要求客户必须自行维修的部件。如果您请求 HP 更换这些部件，则必须为该服务支付差旅费和人工费用。

²Optional: 可选的 — 客户可以选择是否自行维修的部件。这些部件也是为客户自行维修设计的。不过，如果您要求 HP 为您更换这些部件，则根据您的产品指定的保修服务类型，HP 可能收取或不再收取任何附加费用。

³No: 否 — 某些 HP 部件的设计并未考虑客户自行维修。为了满足客户保修的需要，HP 要求授权服务提供商更换相关部件。这些部件在部件图解目录中标记为“否”。

¹Mandatory: 強制的 — 客戶自行維修所使用的零件是強制性的。如果您要求 HP 更換這些零件，HP 將會向您收取此服務所需的外出費用與勞動成本。

²Optional: 選購的 — 客戶自行維修所使用的零件是選購的。這些零件也設計用於客戶自行維修之用。不過，如果您要求 HP 為您更換，則可能需要也可能不需要負擔額外的費用，端視針對此產品指定的保固服務類型而定。

³No: 否 — 某些 HP 零件沒有消費者可自行維修的設計。為符合客戶保固，HP 需要授權的服務供應商更換零件。這些零件在圖示的零件目錄中，被標示為「否」。

¹ Mandatory: 필수 — 고객 셀프 수리가 의무 사항인 필수 부품. 사용자가 HP에 이 부품의 교체를 요청할 경우 이 서비스에 대한 출장비 및 작업비가 청구됩니다.

² Optional: 옵션 — 고객 셀프 수리가 선택 사항인 부품. 이 부품들도 고객 셀프 수리가 가능하도록 설계되었습니다. 하지만 사용자가 HP에 이 부품의 교체를 요청할 경우 사용자가 구입한 제품에 해당하는 보증 서비스 유형에 따라 추가 비용 없이 교체가 가능할 수 있습니다.

³ No: No — 고객 셀프 수리가 불가능하도록 설계된 HP 부품. 이 부품들은 고객 셀프 수리가 불가능하도록 설계되었습니다. HP는 고객 보증을 만족시키기 위해 공인 서비스 제공업체를 통해 부품을 교체하도록 하고 있습니다.

Removal and replacement procedures

Required tools

You need the following items for some procedures:

- T-10/T-15 Torx screwdriver (included with the server)
- HP Insight Diagnostics software ("HP Insight Diagnostics" on page 74)

Safety considerations

Before performing service procedures, review all the safety information.

Preventing electrostatic discharge

To prevent damaging the system, be aware of the precautions you need to follow when setting up the system or handling parts. A discharge of static electricity from a finger or other conductor may damage system boards or other static-sensitive devices. This type of damage may reduce the life expectancy of the device.

To prevent electrostatic damage:

- Avoid hand contact by transporting and storing products in static-safe containers.
- Keep electrostatic-sensitive parts in their containers until they arrive at static-free workstations.
- Place parts on a grounded surface before removing them from their containers.
- Avoid touching pins, leads, or circuitry.
- Always be properly grounded when touching a static-sensitive component or assembly.

Symbols on equipment

The following symbols may be placed on equipment to indicate the presence of potentially hazardous conditions.



This symbol indicates the presence of hazardous energy circuits or electric shock hazards. Refer all servicing to qualified personnel.

WARNING: To reduce the risk of injury from electric shock hazards, do not open this enclosure. Refer all maintenance, upgrades, and servicing to qualified personnel.



This symbol indicates the presence of electric shock hazards. The area contains no user or field serviceable parts. Do not open for any reason.

WARNING: To reduce the risk of injury from electric shock hazards, do not open this enclosure.



This symbol on an RJ-45 receptacle indicates a network interface connection.

WARNING: To reduce the risk of electric shock, fire, or damage to the equipment, do not plug telephone or telecommunications connectors into this receptacle.



This symbol indicates the presence of a hot surface or hot component. If this surface is contacted, the potential for injury exists.

WARNING: To reduce the risk of injury from a hot component, allow the surface to cool before touching.

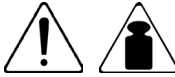

This symbol indicates that the component exceeds the recommended weight for one individual to handle safely.

WARNING: To reduce the risk of personal injury or damage to the equipment, observe local occupational health and safety requirements and guidelines for manual material handling.



These symbols, on power supplies or systems, indicate that the equipment is supplied by multiple sources of power.

WARNING: To reduce the risk of injury from electric shock, remove all power cords to completely disconnect power from the system.

Server warnings and cautions



WARNING: This server is very heavy. To reduce the risk of personal injury or damage to the equipment:

- Observe local occupational health and safety requirements and guidelines for manual material handling.
- Get help to lift and stabilize the product during installation or removal, especially when the product is not fastened to the rails. HP recommends that a minimum of two people are required for all rack server installations. A third person may be required to help align the server if the server is installed higher than chest level.
- Use caution when installing the server in or removing the server from the rack; it is unstable when not fastened to the rails.



WARNING: To reduce the risk of personal injury from hot surfaces, allow the drives and the internal system components to cool before touching them.



WARNING: To reduce the risk of personal injury, electric shock, or damage to the equipment, remove the power cord to remove power from the server. The front panel Power On/Standby button does not completely shut off system power. Portions of the power supply and some internal circuitry remain active until AC power is removed.



CAUTION: Protect the server from power fluctuations and temporary interruptions with a regulating uninterruptible power supply. This device protects the hardware from damage caused by power surges and voltage spikes and keeps the system in operation during a power failure.



CAUTION: Do not operate the server for long periods with the access panel open or removed. Operating the server in this manner results in improper airflow and improper cooling that can lead to thermal damage.

Preparation procedures

To access some components and perform certain service procedures, you must perform one or more of the following procedures:

- Power down the server (on page 25).
- Remove the access panel (on page 25).
- Remove the front bezel (on page 26).
- Remove the PCI air baffle (on page 27).
- Remove the system air baffle (on page 28).

Power down the server

Before powering down the server for any upgrade or maintenance procedures, perform a backup of critical server data and programs.



IMPORTANT: When the server is in standby mode, auxiliary power is still being provided to the system.

To power down the server, use one of the following methods:

- Press and release the Power On/Standby button.
This method initiates a controlled shutdown of applications and the OS before the server enters standby mode.
- Press and hold the Power On/Standby button for more than 4 seconds to force the server to enter standby mode.
This method forces the server to enter standby mode without properly exiting applications and the OS. If an application stops responding, you can use this method to force a shutdown.
- Use a virtual power button selection through iLO 4.
This method initiates a controlled remote shutdown of applications and the OS before the server enters standby mode.

Before proceeding, verify the server is in standby mode by observing that the system power LED is amber.

Remove the access panel



WARNING: To reduce the risk of personal injury from hot surfaces, allow the drives and the internal system components to cool before touching them.



CAUTION: For proper cooling do not operate the server without the access panel, baffles, expansion slot covers, or blanks installed.



CAUTION: To prevent damage to electrical components, take the appropriate anti-static precautions before beginning any installation, removal, or replacement procedure. Improper grounding can cause electrostatic discharge.

1. Power down the server (on page 25).
2. Remove all power:

- a. Disconnect each power cord from the power source.
 - b. Disconnect each power cord from the server.
 3. Place the server on its side.
 4. Remove the access panel:
 - a. Loosen the access panel thumbscrews.
 - b. Slide and remove the access panel from the server.

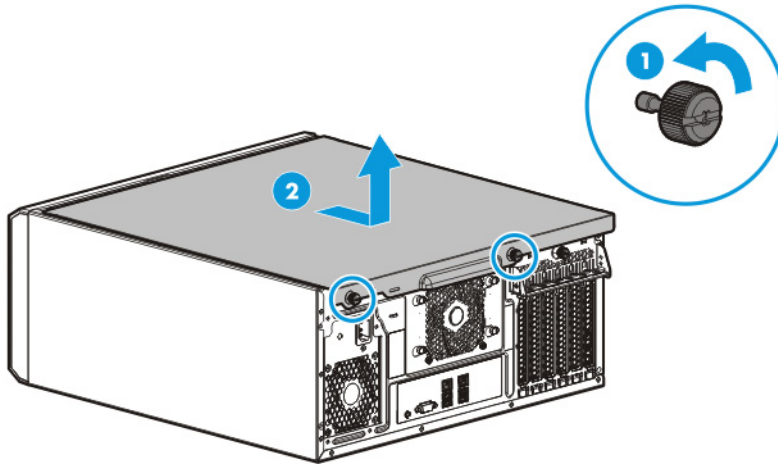

Remove the front bezel

1. Power down the server (on page 25).
2. Remove all power:
 - a. Disconnect each power cord from the power source.
 - b. Disconnect each power cord from the server.
3. Place the server on its side.
4. Remove the access panel (on page 25).

5. Unlock the internal locker. Then open and remove the front bezel.

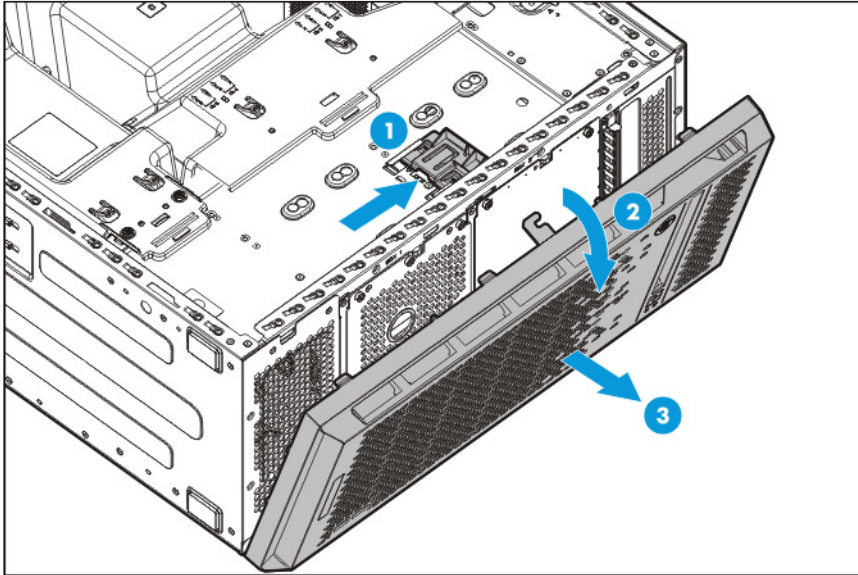

Remove the PCI air baffle

1. Power down the server (on page 25).
2. Remove all power:
 - a. Disconnect each power cord from the power source.
 - b. Disconnect each power cord from the server.
3. Place the server on its side.
4. Remove the access panel (on page 25).
5. Remove the PCI air baffle.

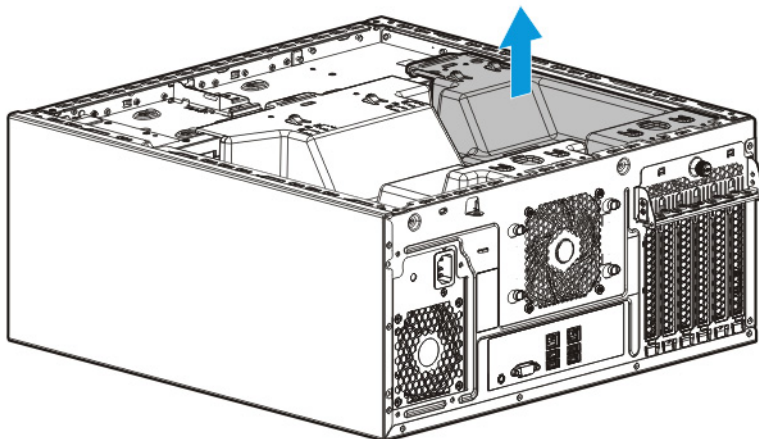

Remove the system air baffle

1. Power down the server (on page 25).
2. Remove all power:
 - a. Disconnect each power cord from the power source.
 - b. Disconnect each power cord from the server.
3. Place the server on its side.
4. Remove the access panel (on page 25).
5. If installed, remove the PCI air baffle (on page 27).
6. Remove the system air baffle.

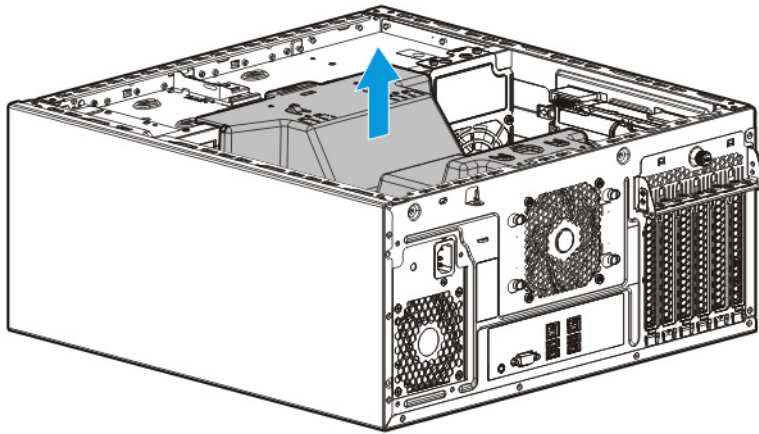

Non-hot-plug drive cage



CAUTION: To prevent improper cooling and thermal damage, do not operate the server unless all bays are populated with either a component or a blank.

To remove the component:

1. Back up all server data on the drive.
2. Power down the server (on page 25).
3. Remove all power:
 - a. Disconnect each power cord from the power source.
 - b. Disconnect each power cord from the server.
4. Place the server on its side.
5. Remove the access panel (on page 25).
6. Remove the front bezel (on page 26).
7. If installed, remove the PCI air baffle (on page 27).
8. Remove the system air baffle (on page 28).

9. Disconnect all existing drive cables.
10. Remove the non-hot-plug drive cage.

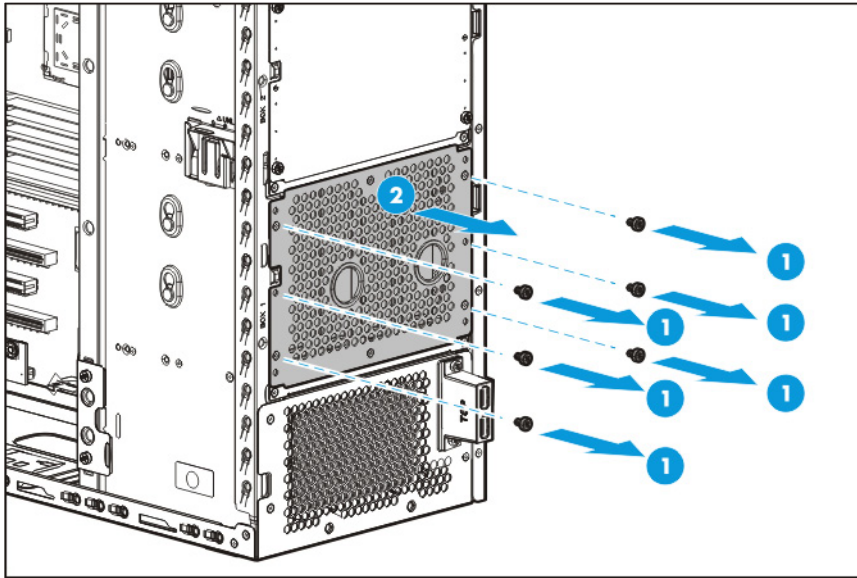

To replace the component, reverse the removal procedure.

Non-hot-plug drive

⚠ CAUTION: To prevent improper cooling and thermal damage, do not operate the server unless all bays are populated with either a component or a blank.

To remove the component:

1. Back up all server data on the drive.
2. Power down the server (on page 25).
3. Remove all power:
 - a. Disconnect each power cord from the power source.
 - b. Disconnect each power cord from the server.
4. Place the server on its side.
5. Remove the access panel (on page 25).
6. Remove the front bezel (on page 26).
7. If installed, remove the PCI air baffle (on page 27).
8. Remove the system air baffle (on page 28).
9. Disconnect all existing drive cables.
10. Remove the non-hot-plug drive cage ("Non-hot-plug drive cage" on page 28).

11. Remove the non-hot-plug drive.

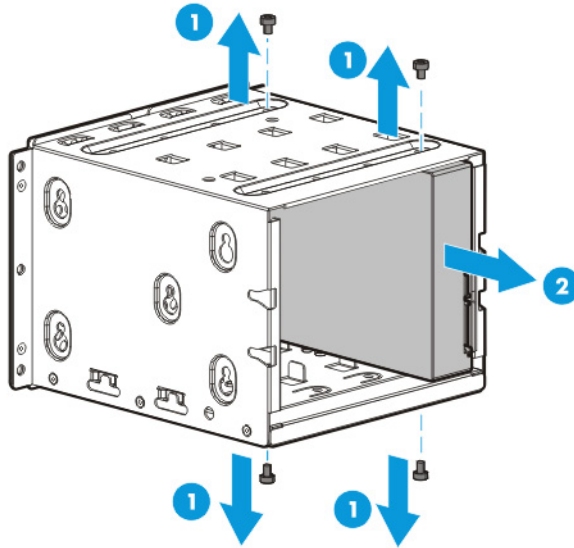

To replace the component, reverse the removal procedure.

Hot-plug drive blanks

CAUTION: To prevent improper cooling and thermal damage, do not operate the server unless all bays are populated with either a component or a blank.

To remove the component:

1. Remove the front bezel (on page 26).
2. Remove the drive blank.
 - o Hot-plug LFF drive blank

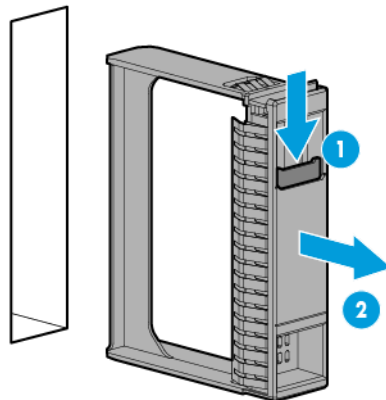

To replace the LFF drive blank, slide the component into the bay until it clicks.

- Hot-plug SFF drive blank

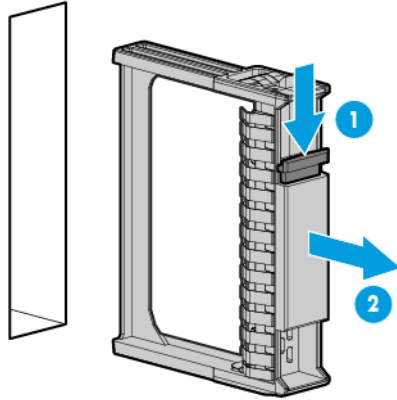

To replace the SFF drive blank, while pressing the release latch, slide the component into the bay until it is fully seated.

Hot-plug drive

CAUTION: To prevent improper cooling and thermal damage, do not operate the server unless all bays are populated with either a component or a blank.

To remove the component:

1. Back up all server data on the drive.
2. Remove the front bezel (on page 26).
3. Determine the status of the drive from the drive LED definitions ("HP SmartDrive LED definitions" on page 86).
4. Remove the hot-plug drive.

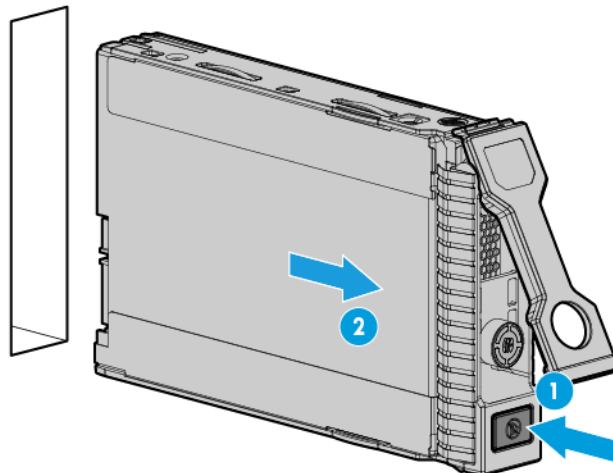

To replace the component, reverse the removal procedure.

4-bay LFF hot-plug drive cage

⚠ WARNING: To reduce the risk of personal injury from hot surfaces, allow the drives and the internal system components to cool before touching them.

To remove the component:

1. Power down the server (on page 25).
2. Remove all power:
 - a. Disconnect each power cord from the power source.
 - b. Disconnect each power cord from the server.
3. Place the server on its side.
4. Remove the access panel (on page 25).
5. Remove the front bezel (on page 26).
6. Remove all drives ("Hot-plug drive" on page 31).
7. Remove all drive blanks ("Hot-plug drive blanks" on page 30).
8. If installed, remove the PCI air baffle (on page 27).
9. Remove the system air baffle (on page 28).
10. Disconnect the Mini-SAS cable and the power cable from the drive backplane.
11. Disconnect the hard drive power good cable from the system board. Hard drive power good cable is attached to the drive cage by default.
12. Remove the LFF hot-plug drive cage:
 - o Box 1

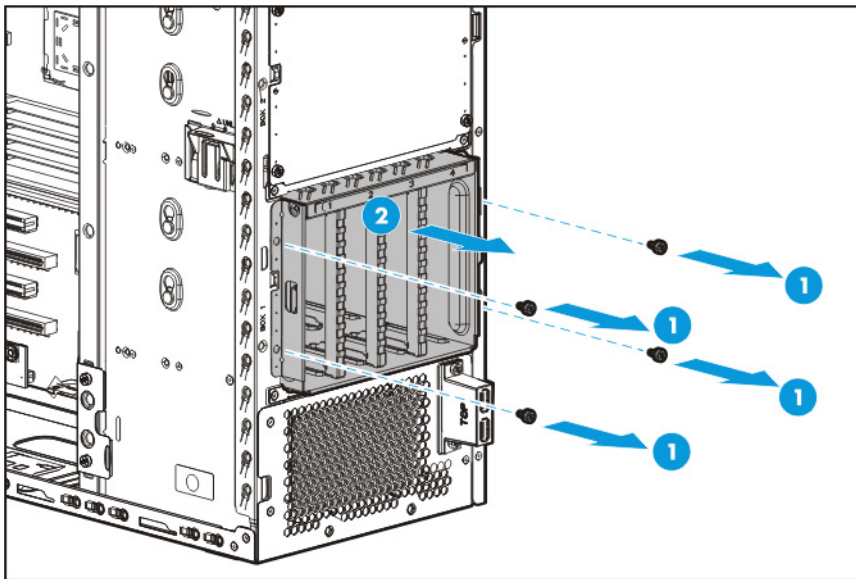

- Box 2

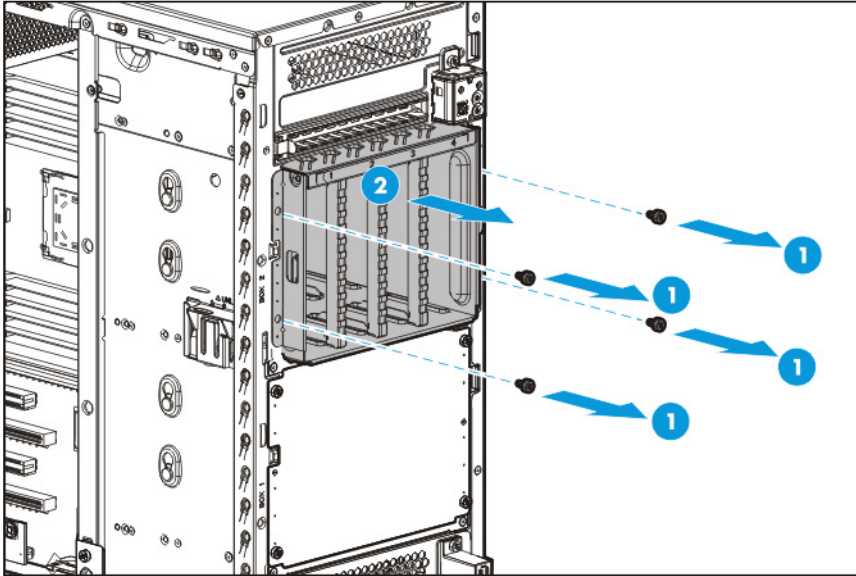

To replace the component, reverse the removal procedure.

8-bay SFF hot-plug drive cage

⚠ WARNING: To reduce the risk of personal injury from hot surfaces, allow the drives and the internal system components to cool before touching them.

To remove the component:

1. Power down the server (on page 25).
2. Remove all power:
 - a. Disconnect each power cord from the power source.
 - b. Disconnect each power cord from the server.
3. Place the server on its side.
4. Remove the access panel (on page 25).
5. Remove the front bezel (on page 26).
6. Remove all drives ("Hot-plug drive" on page 31).
7. Remove all drive blanks ("Hot-plug drive blanks" on page 30).
8. If installed, remove the PCI air baffle (on page 27).
9. Remove the system air baffle (on page 28).
10. Disconnect the Mini-SAS cable and the power cable from the drive backplane.
11. Disconnect the hard drive power good cable from the system board. Hard drive power good cable is attached to the drive cage by default.
12. Remove the SFF hot-plug drive cage.

○ Box 1

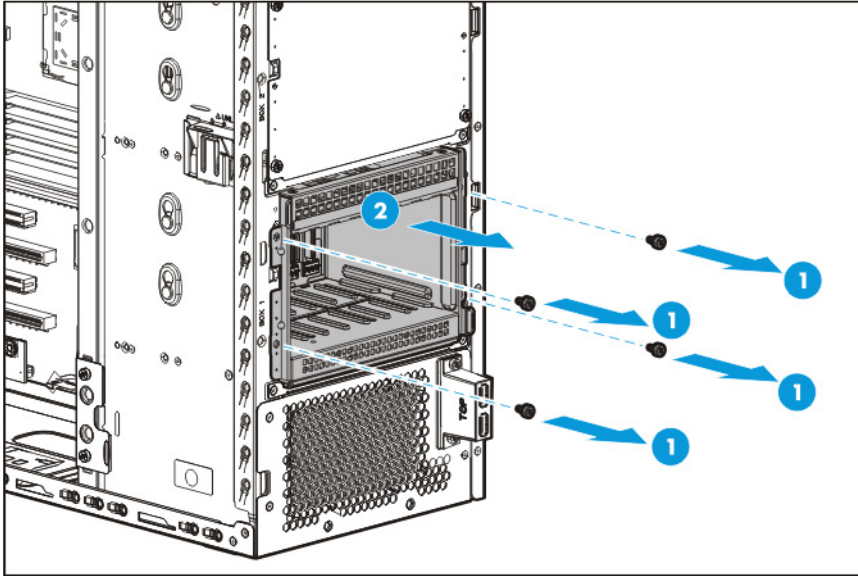

○ Box 2

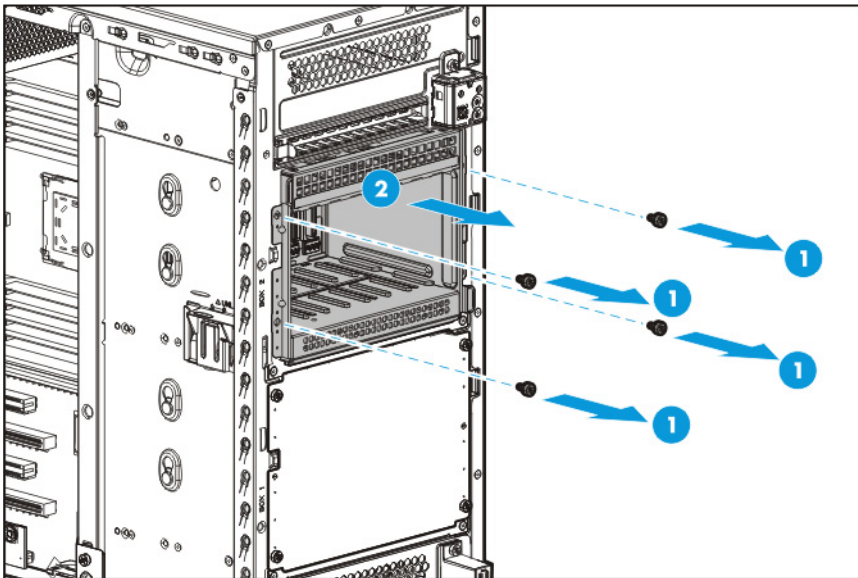

To replace the component, reverse the removal procedure.

Optical drive

To remove the component:

1. Power down the server (on page 25).
2. Remove all power:
 - a. Disconnect each power cord from the power source.
 - b. Disconnect each power cord from the server.
3. Place the server on its side.
4. Remove the access panel (on page 25).

5. Remove the front bezel (on page 26).
6. If installed, remove the PCI air baffle (on page 27).
7. Remove the system air baffle (on page 28).
8. Disconnect the power and SATA cable.
9. Release cables from clip and metal tabs.

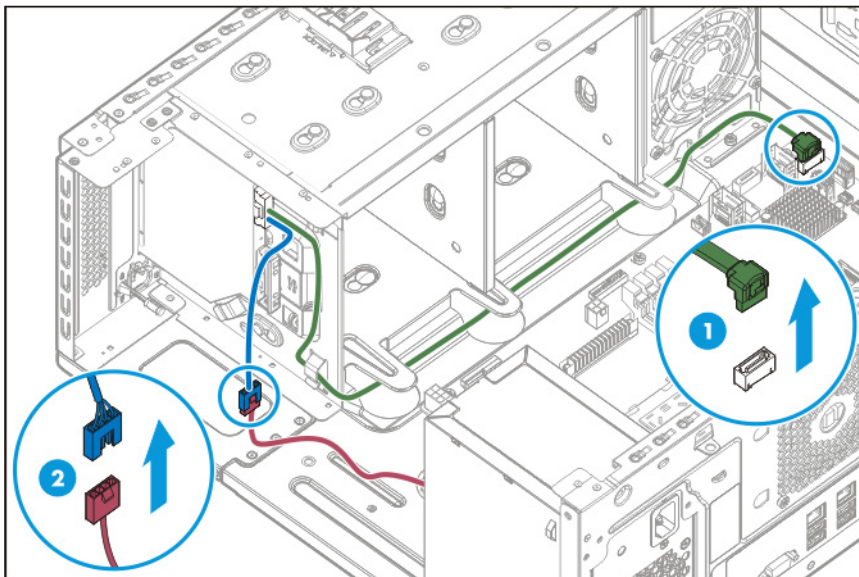

10. Press the metal tab.

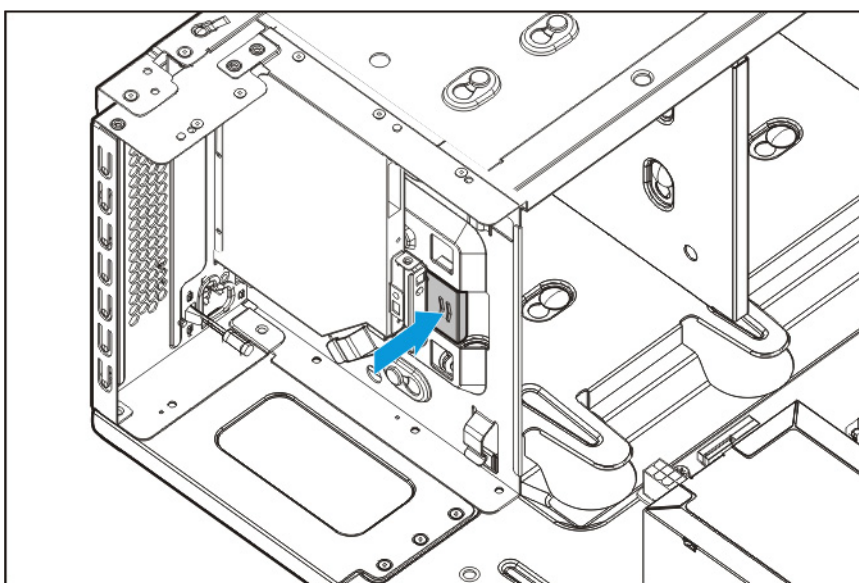

11. Remove the optical drive and disconnect the cable from the rear of the drive.

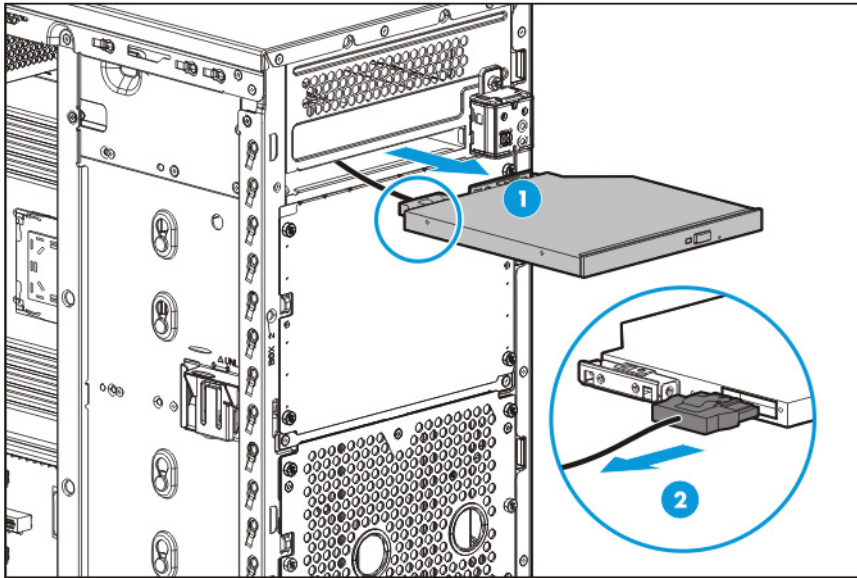

To replace the component, reverse the removal procedure.

Fans

System fan module (92 x 32 mm)

To remove the component:

1. Power down the server (on page 25).
2. Remove all power:
 - a. Disconnect each power cord from the power source.
 - b. Disconnect each power cord from the server.
3. Place the server on its side.
4. Remove the access panel (on page 25).
5. If installed, remove the PCI air baffle (on page 27).
6. Remove the system air baffle (on page 28).

7. Remove the 92 × 32 mm system fan module.

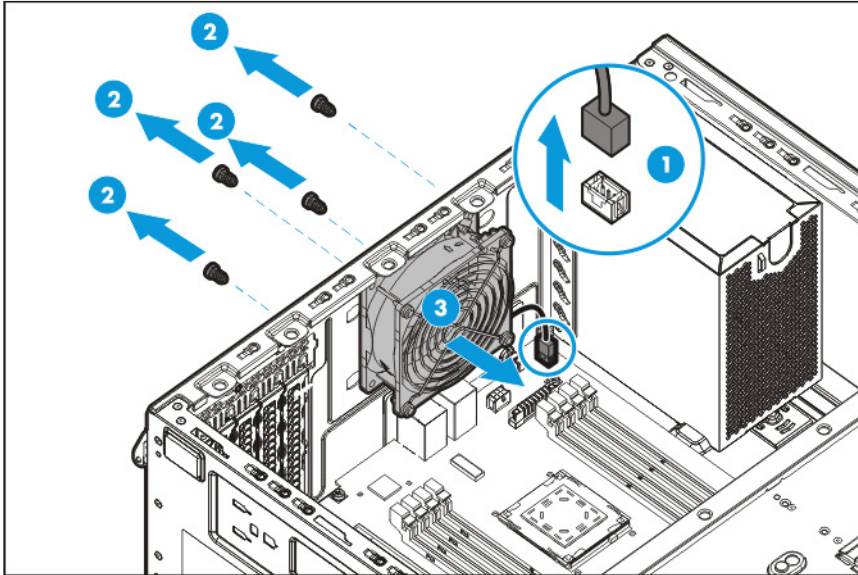

To replace the component, reverse the removal procedure.

Upgrade fan module (92 x 38 mm)

To remove the component:

1. Power down the server (on page 25).
2. Remove all power:
 - a. Disconnect each power cord from the power source.
 - b. Disconnect each power cord from the server.
3. Place the server on its side.
4. Remove the access panel (on page 25).
5. If installed, remove the PCI air baffle (on page 27).
6. Remove the system air baffle (on page 28).

7. Press the middle of fan guard on rear panel.

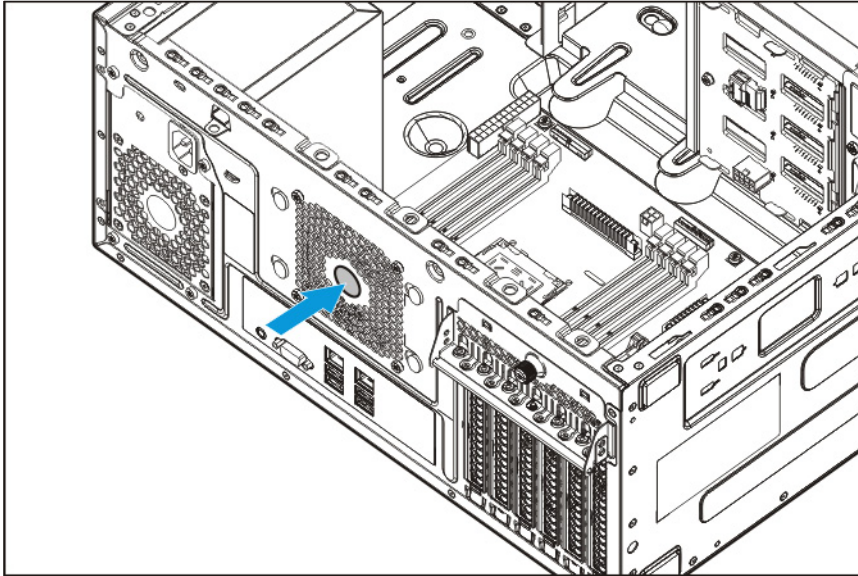

8. Remove the 92 × 38 mm system fan module.

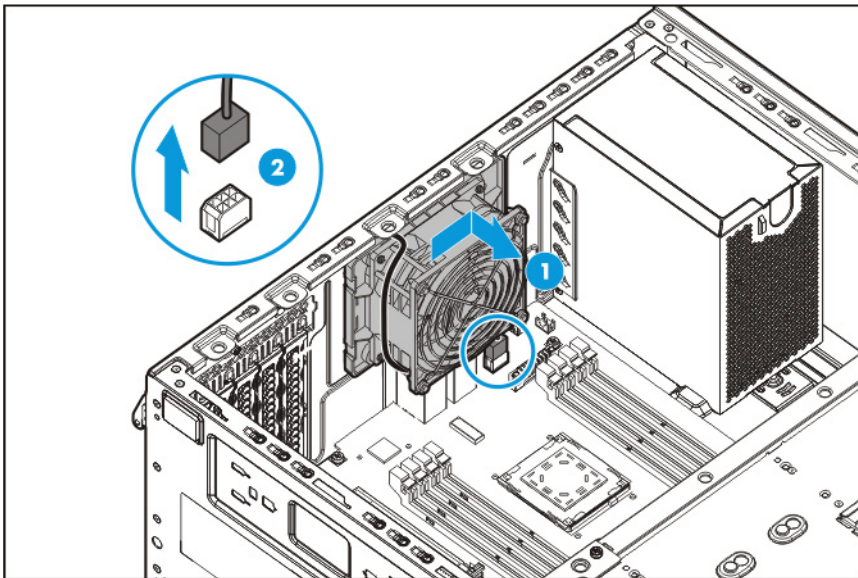

To replace the component, reverse the removal procedure.

PCI fan module

CAUTION: For proper cooling do not operate the server without the access panel, baffles, expansion slot covers, or blanks installed.

To remove the component:

1. Power down the server (on page 25).
2. Remove all power:
 - a. Disconnect each power cord from the power source.
 - b. Disconnect each power cord from the server.

3. Place the server on its side.
4. Remove the access panel (on page 25).
5. If installed, remove the PCI air baffle (on page 27).
6. Remove the system air baffle (on page 28).
7. Disconnect the fan power cable and remove the PCI fan.

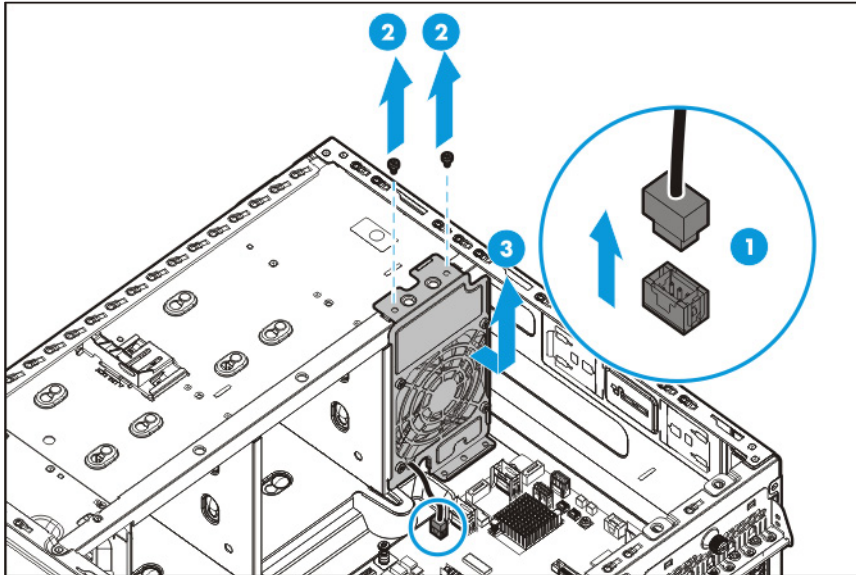

To replace the component, reverse the removal procedure.

GPU supporting holder

To remove the component:

1. Power down the server (on page 25).
2. Remove all power:
 - a. Disconnect each power cord from the power source.
 - b. Disconnect each power cord from the server.
3. Place the server on its side.
4. Remove the access panel (on page 25).
5. If installed, remove the PCI air baffle (on page 27).
6. Remove the system air baffle (on page 28).

7. Disconnect the 6-pin power cable from the GPU.

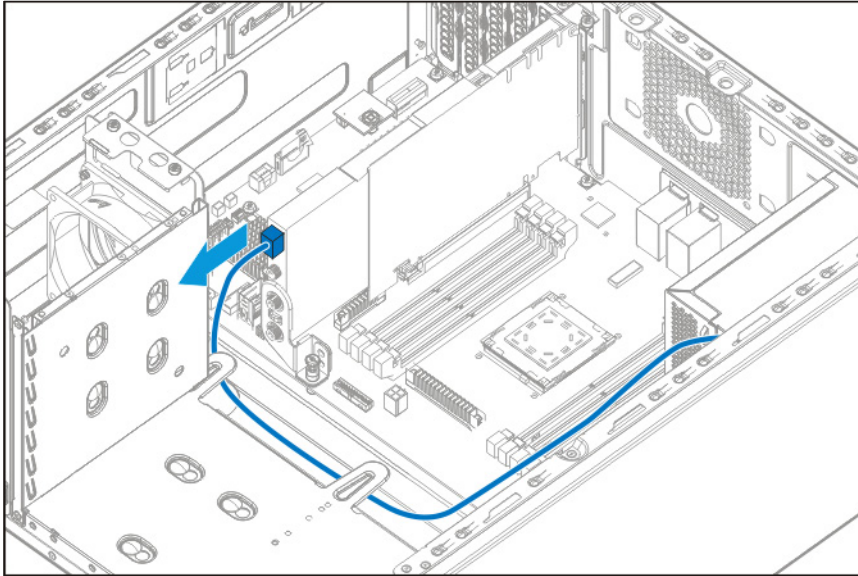

8. Remove the GPU with the supporting holder from slot 1:
- a. Open the PCIe slot cover retainer.
 - b. Loosen the captive screw of the supporting holder.
 - c. Open the latch on the slot 1 and remove the GPU.

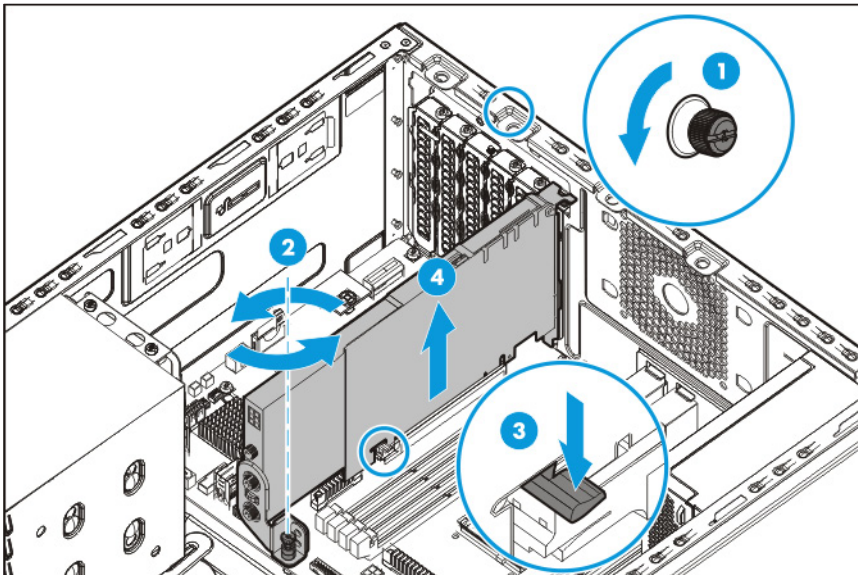

9. Remove the supporting holder.

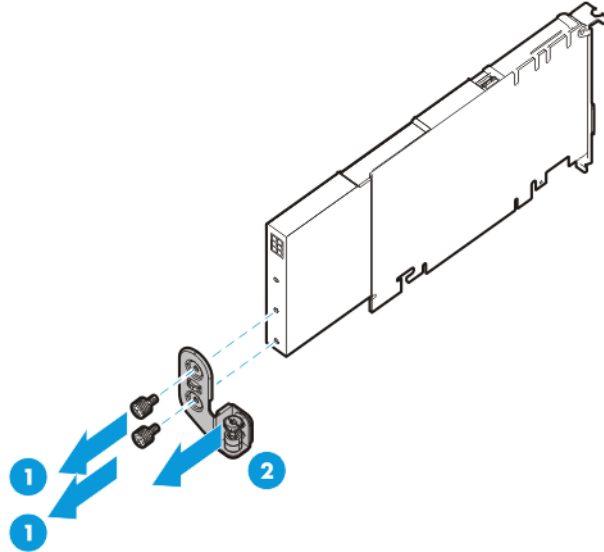

To replace the component, reverse the removal procedure.

FBWC module

-
- ⚠ **WARNING:** To reduce the risk of personal injury from hot surfaces, allow the drives and the internal system components to cool before touching them.
-
- ⚠ **CAUTION:** In systems that use external data storage, be sure that the server is the first unit to be powered down and the last to be powered back up. Taking this precaution ensures that the system does not erroneously mark the drives as failed when the server is powered up.
-
- ⚠ **CAUTION:** To prevent damage to electrical components, take the appropriate anti-static precautions before beginning any installation, removal, or replacement procedure. Improper grounding can cause electrostatic discharge.
-

To remove the component:

1. Power down the server (on page 25).
2. Remove all power:
 - a. Disconnect each power cord from the power source.
 - b. Disconnect each power cord from the server.
3. Place the server on its side.
4. Remove the access panel (on page 25).
5. If installed, remove the PCI air baffle (on page 27).
6. Remove the system air baffle (on page 28).

- ⚠ **CAUTION:** When connecting or disconnecting the cache module cable, the connectors on the cache module and cable are susceptible to damage. Avoid excessive force and use caution to avoid damage to these connectors.
-

7. If necessary for easier access to the cache module connector and/or removal of an air scoop, remove the storage controller from the PCI riser cage or from the system board.
8. If the cache module is covered by an air scoop, remove the air scoop.
9. Disconnect the cache module backup power cable from the cache module.

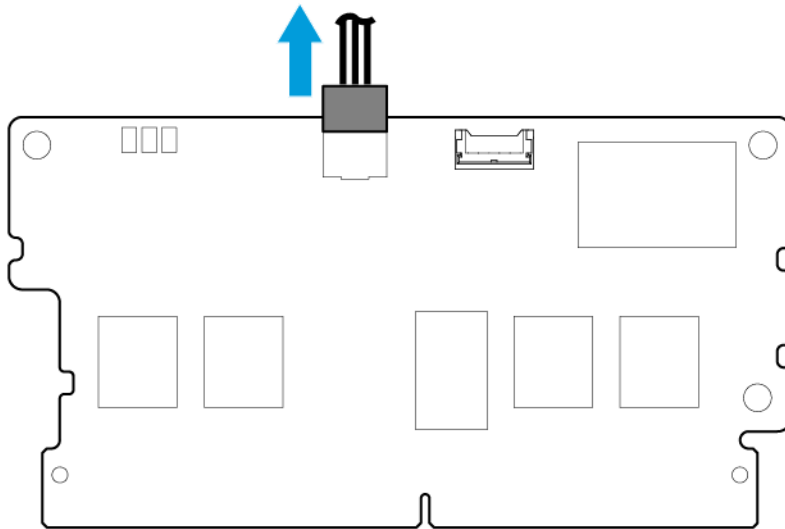

10. Remove the cache module.

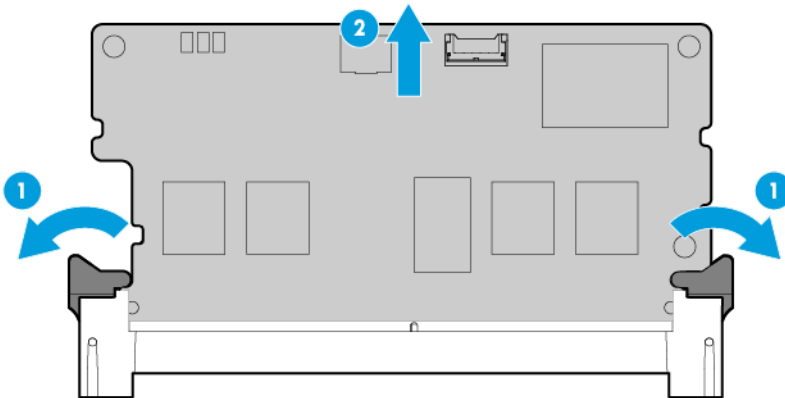

To replace the component, reverse the removal procedure.

HP Smart Storage Battery

- WARNING:** To reduce the risk of personal injury from hot surfaces, allow the drives and the internal system components to cool before touching them.
- CAUTION:** To prevent damage to electrical components, take the appropriate anti-static precautions before beginning any installation, removal, or replacement procedure. Improper grounding can cause electrostatic discharge.

To remove the component:

1. Power down the server (on page 25).
2. Remove all power:
 - a. Disconnect each power cord from the power source.
 - b. Disconnect each power cord from the server.
3. Place the server on its side.
4. Remove the access panel (on page 25).
5. If installed, remove the PCI air baffle (on page 27).
6. Remove the system air baffle (on page 28).
7. Disconnect the battery cable from the system board connector and remove the HP Smart Storage Battery.

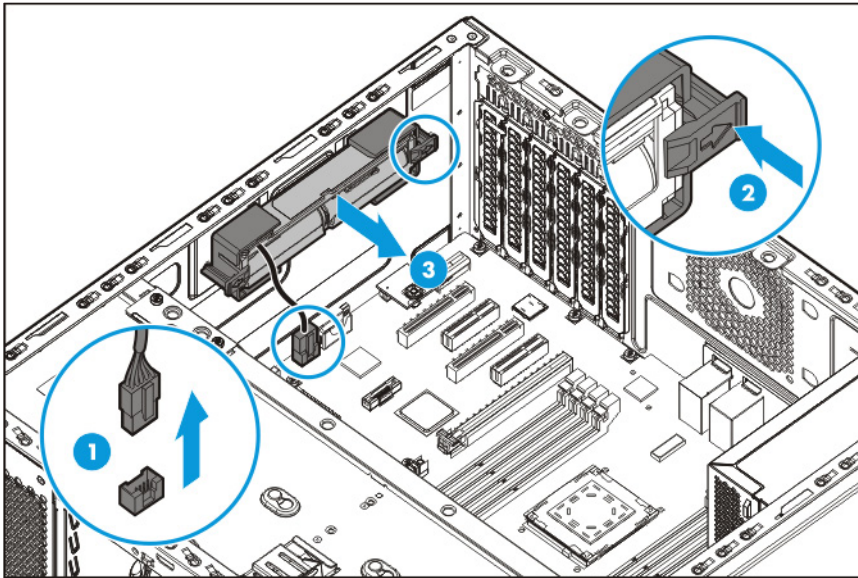

To replace the component, reverse the removal procedure.

DIMMs

To remove the component:

1. Power down the server (on page 25).
2. Remove all power:
 - a. Disconnect each power cord from the power source.
 - b. Disconnect each power cord from the server.
3. Place the server on its side.
4. Remove the access panel (on page 25).
5. If installed, remove the PCI air baffle (on page 27).
6. Remove the system air baffle (on page 28).
7. Open the DIMM slot latches.

8. Remove the DIMM.

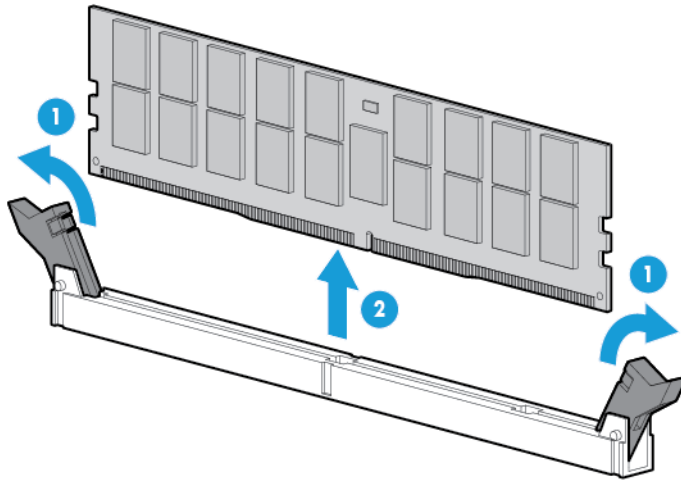

To replace the component, reverse the removal procedure.

Heatsink

To remove the component:

1. Power down the server (on page 25).
2. Remove all power:
 - a. Disconnect each power cord from the power source.
 - b. Disconnect each power cord from the server.
3. Place the server on its side.
4. Remove the access panel (on page 25).
5. If installed, remove the PCI air baffle (on page 27).
6. Remove the system air baffle (on page 28).
7. Remove the heatsink:
 - a. Loosen one pair of diagonally opposite screws halfway, and then loosen the other pair of screws.
 - b. Completely loosen all screws in the same sequence.

- c. Remove the heatsink from the processor backplate.

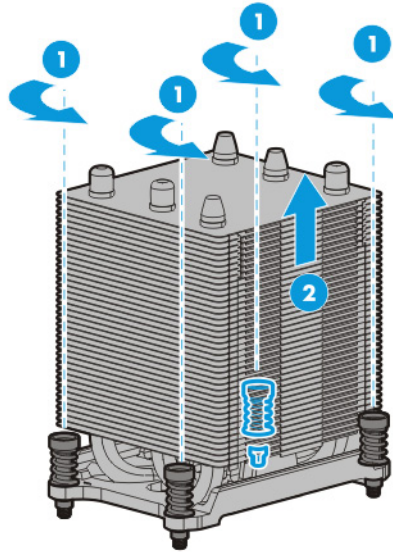

To replace the component:

1. Clean the old thermal grease from the processor with the alcohol swab. Allow the alcohol to evaporate before continuing.
2. Remove the thermal interface protective cover from the heatsink.

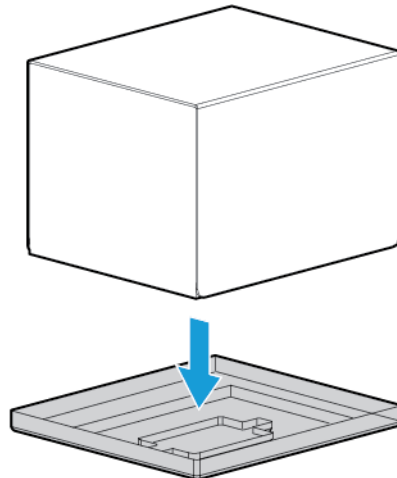

3. Install the heatsink:
 - a. Position the heatsink on the processor backplate.
 - b. Tighten one pair of diagonally opposite screws halfway, and then tighten the other pair of screws.

- c. Finish the installation by completely tightening the screws in the same sequence.

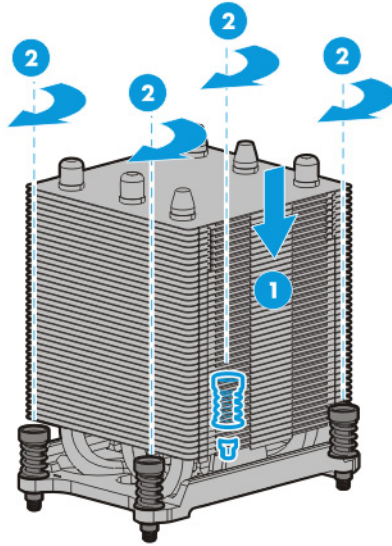

4. Install the system air baffle.
5. If removed, install the PCI air baffle.
6. Install the access panel.
7. Return the server to an upright position.
8. Connect each power cord to the server.
9. Connect each power cord to the power source.
10. Power up the server.

Processor

-
- ⚠ WARNING:** To reduce the risk of personal injury from hot surfaces, allow the drives and the internal system components to cool before touching them.
-
- ⚠ CAUTION:** To avoid damage to the processor and system board, only authorized personnel should attempt to replace or install the processor in this server.
-
- ⚠ CAUTION:** To prevent possible server malfunction and damage to the equipment, multiprocessor configurations must contain processors with the same part number.
-
- ⚠ CAUTION:** To prevent damage to electrical components, take the appropriate anti-static precautions before beginning any installation, removal, or replacement procedure. Improper grounding can cause electrostatic discharge.
-
- 📝 IMPORTANT:** If installing a processor with a faster speed, update the system ROM before installing the processor.
-

To remove the component:

1. Power down the server (on page 25).
2. Remove all power:

- a. Disconnect each power cord from the power source.
 - b. Disconnect each power cord from the server.
3. Place the server on its side.
4. Remove the access panel (on page 25).
5. If installed, remove the PCI air baffle (on page 27).
6. Remove the system air baffle (on page 28).
7. Remove the heatsink:
 - a. Loosen one pair of diagonally opposite screws halfway, and then loosen the other pair of screws.
 - b. Completely loosen all screws in the same sequence.
 - c. Remove the heatsink from the processor backplate.

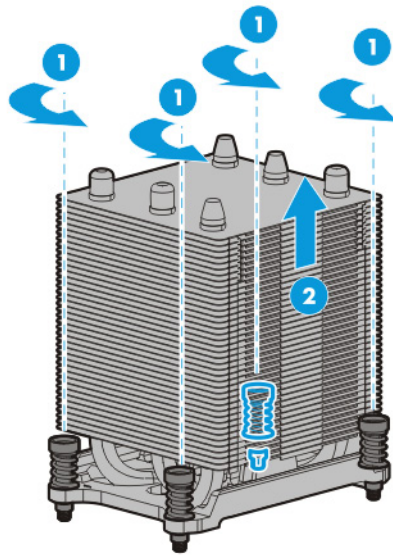

8. Open each of the processor locking levers in the order indicated, and then open the processor retaining bracket.

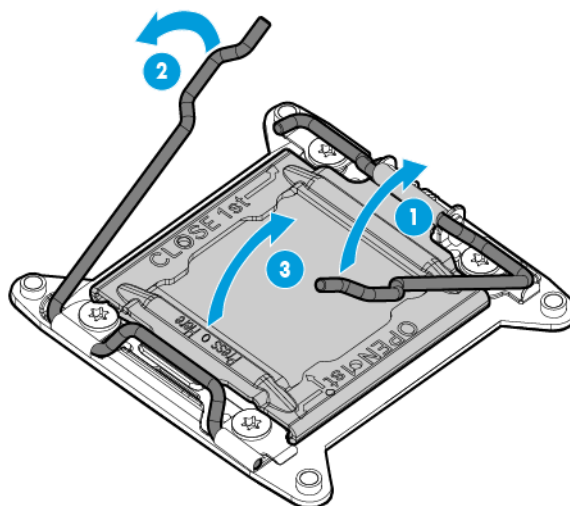



CAUTION: THE PINS ON THE SYSTEM BOARD ARE VERY FRAGILE AND EASILY DAMAGED. To avoid damage to the system board, do not touch the processor or the processor socket contacts.

9. Remove the processor from the processor retaining bracket.

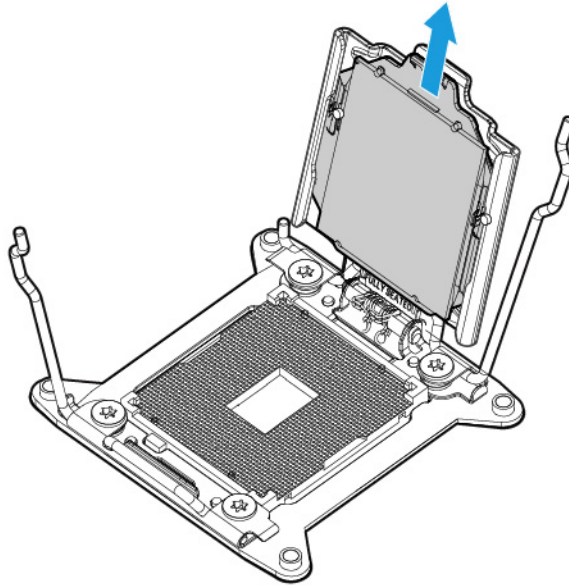

To replace the component:

1. Install the processor. Verify that the processor is fully seated in the processor retaining bracket by visually inspecting the processor installation guides on either side of the processor. **THE PINS ON THE SYSTEM BOARD ARE VERY FRAGILE AND EASILY DAMAGED.**

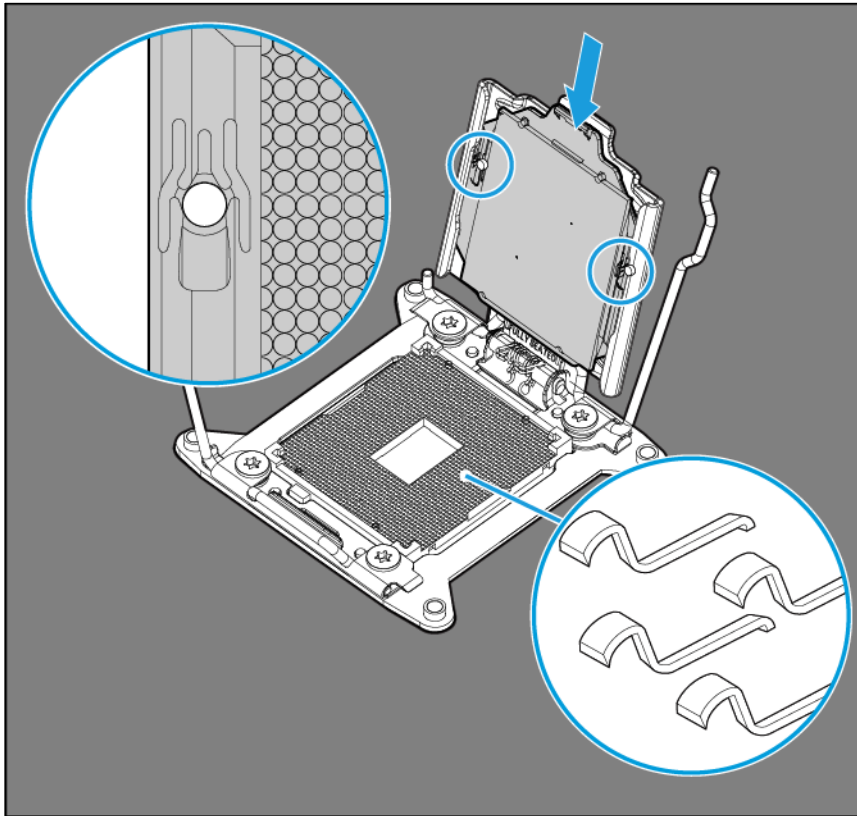

△ **CAUTION:** THE PINS ON THE SYSTEM BOARD ARE VERY FRAGILE AND EASILY DAMAGED. To avoid damage to the system board, do not touch the processor or the processor socket contacts.

△ **CAUTION:** Do not press down on the processor. Pressing down on the processor may cause damage to the processor socket and the system board. Press only in the area indicated on the processor retaining bracket.

2. Close the processor retaining bracket. When the processor is installed properly inside the processor retaining bracket, the processor retaining bracket clears the flange on the front of the socket.

3. Press and hold the processor retaining bracket in place, and then close each processor locking lever. Press only in the area indicated on the processor retaining bracket.

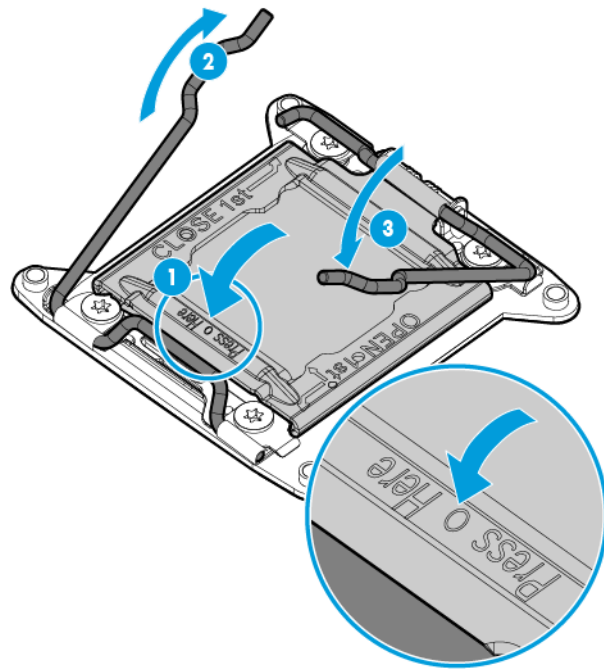

4. Clean the old thermal grease from the heatsink with the alcohol swab. Allow the alcohol to evaporate before continuing.
5. Apply all the grease to the top of the processor in the following pattern to ensure even distribution.

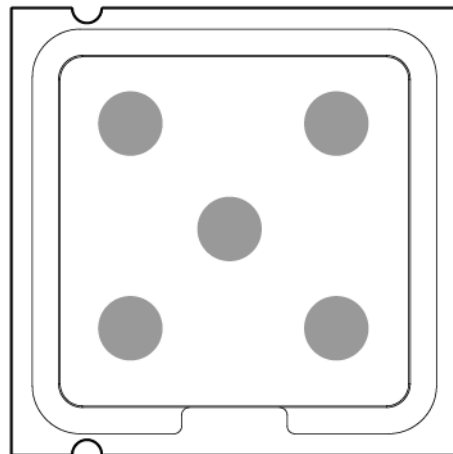

6. Install the heatsink:
 - a. Position the heatsink on the processor backplate.
 - b. Tighten one pair of diagonally opposite screws halfway, and then tighten the other pair of screws.

- c. Finish the installation by completely tightening the screws in the same sequence.

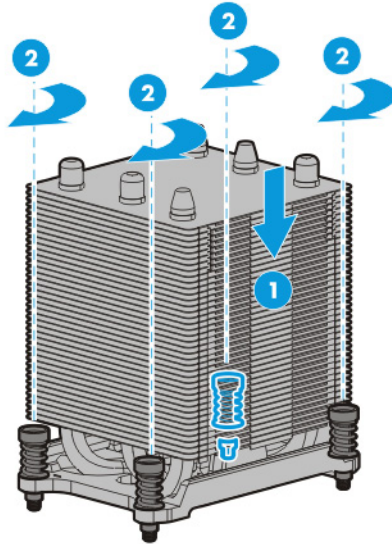

7. Install the system air baffle.
8. If removed, install the PCI air baffle.
9. Install the access panel.
10. Return the server to an upright position.
11. Connect each power cord to the server.
12. Connect each power cord to the power source.
13. Power up the server.

System board

To remove the component:

1. Power down the server (on page 25).
2. Remove all power:
 - a. Disconnect each power cord from the power source.
 - b. Disconnect each power cord from the server.
3. Place the server on its side.
4. Remove the access panel (on page 25).
5. If installed, remove the PCI air baffle (on page 27).
6. Remove the system air baffle (on page 28).
7. Remove all DIMMs ("DIMMs" on page 43).
8. If installed, remove the dedicated iLO module ("Dedicated iLO port management module" on page 59).
9. Disconnect any cables connected to installed PCIe cards.
10. Remove any installed PCIe cards.
11. Disconnect all cables connected to the system board.
12. Remove the heatsink:

- a. Loosen one pair of diagonally opposite screws halfway, and then loosen the other pair of screws.
- b. Completely loosen all screws in the same sequence.
- c. Remove the heatsink from the processor backplate.

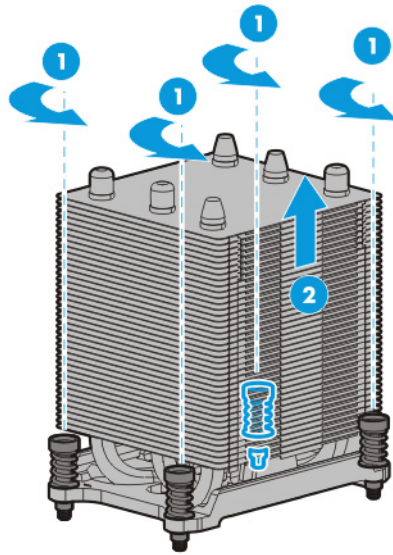

13. Open each of the processor locking levers in the order indicated, and then open the processor retaining bracket.

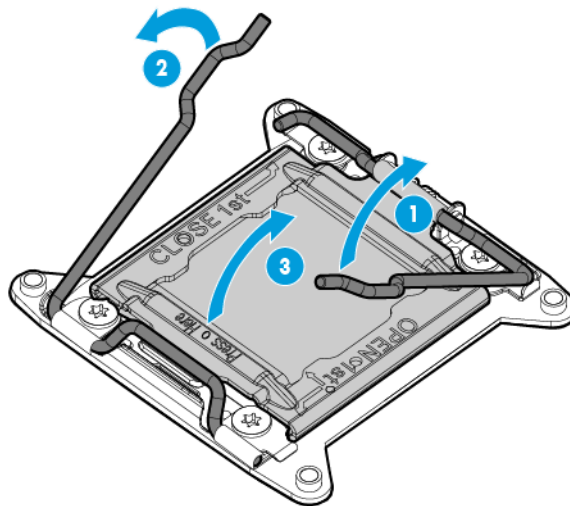

CAUTION: THE PINS ON THE SYSTEM BOARD ARE VERY FRAGILE AND EASILY DAMAGED. To avoid damage to the system board, do not touch the processor or the processor socket contacts.

14. Remove the processor from the processor retaining bracket.

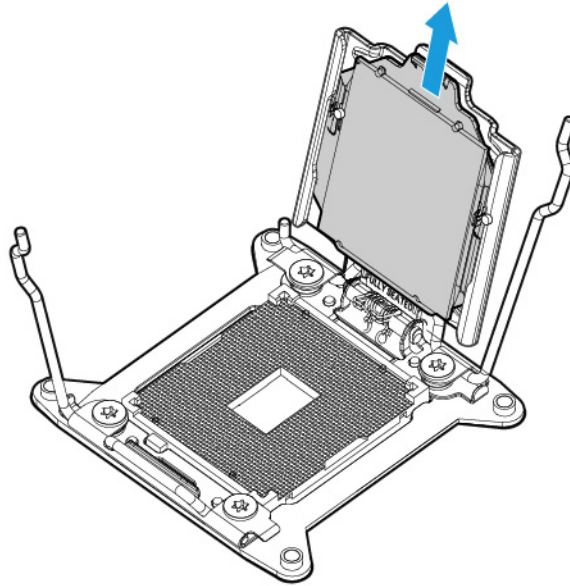

CAUTION: To avoid damage to the system board:

- Do not touch the processor socket contacts.
- Always install the processor socket cover after removing the processor from the socket.
- Do not tilt or slide the processor when lowering the processor into the socket.



CAUTION: Removal of the processor or heatsink renders the thermal layer between the processor and heatsink useless. Clean the component with the provided alcohol swab, then add thermal grease.

15. Place the processor on a static-dissipating work surface or inside an anti-static bag.

16. Remove the failed system board.

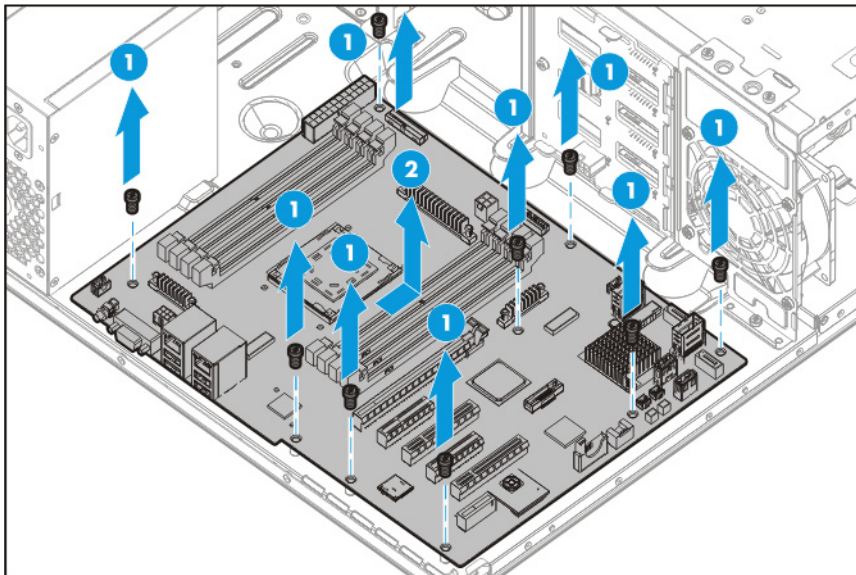

To replace the system board:

1. Install the system board.

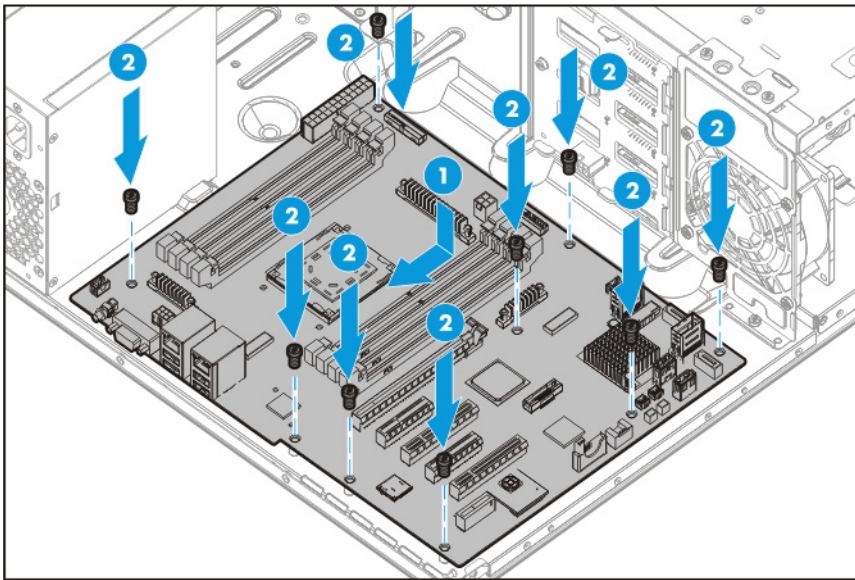

2. Open each of the processor locking levers in the order indicated in the following illustration, and then open the processor retaining bracket.

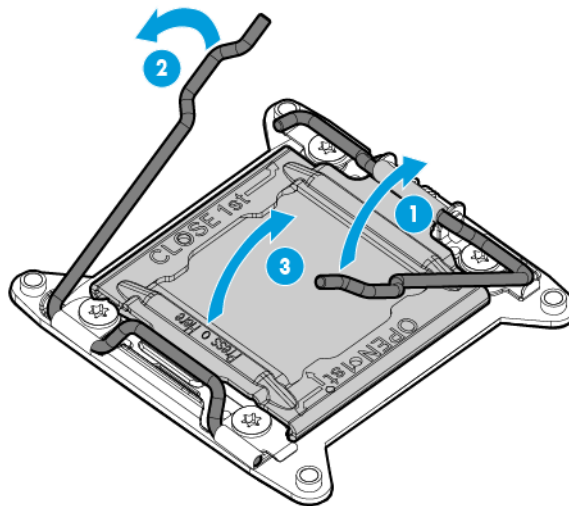

3. Remove the clear processor socket cover. Retain the processor socket cover for future use.

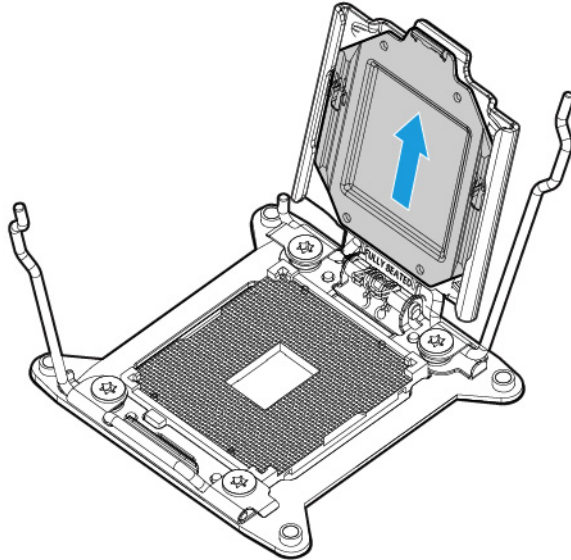

CAUTION: THE PINS ON THE SYSTEM BOARD ARE VERY FRAGILE AND EASILY DAMAGED. To avoid damage to the system board, do not touch the processor or the processor socket contacts.

4. Install the processor. Verify that the processor is fully seated in the processor retaining bracket by visually inspecting the processor installation guides on either side of the processor. **THE PINS ON THE SYSTEM BOARD ARE VERY FRAGILE AND EASILY DAMAGED.**

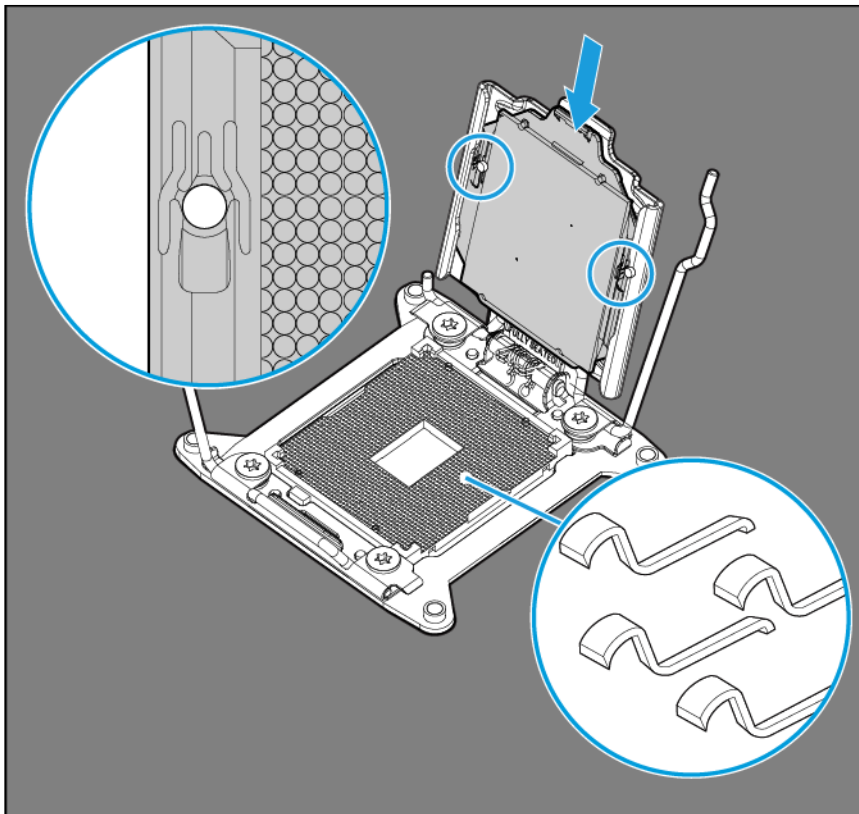

5. Close the processor retaining bracket. When the processor is installed properly inside the processor retaining bracket, the processor retaining bracket clears the flange on the front of the socket.

△ **CAUTION:** Do not press down on the processor. Pressing down on the processor may cause damage to the processor socket and the system board. Press only in the area indicated on the processor retaining bracket.

△ **CAUTION:** Close and hold down the processor cover socket while closing the processor locking levers. The levers should close without resistance. Forcing the levers closed can damage the processor and socket, requiring system board replacement.

6. Press and hold the processor retaining bracket in place, and then close each processor locking lever. Press only in the area indicated on the processor retaining bracket.

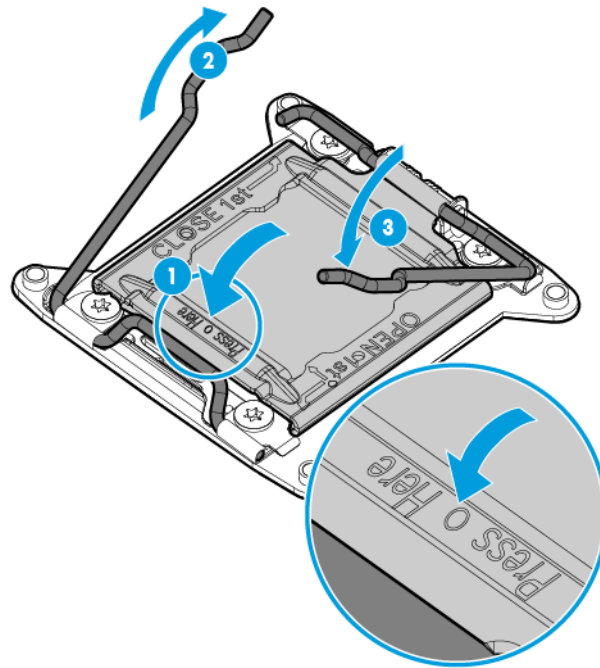

7. Clean the old thermal grease from the heatsink and the top of the processor with the alcohol swab. Allow the alcohol to evaporate before continuing.
8. Apply all the grease to the top of the processor in the following pattern to ensure even distribution.

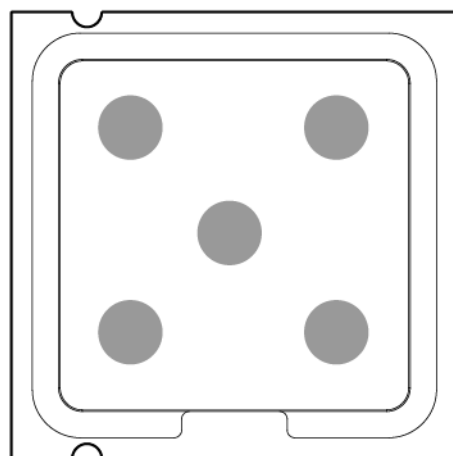

9. Install the heatsink:

- a. Position the heatsink on the processor backplate.
- b. Tighten one pair of diagonally opposite screws halfway, and then tighten the other pair of screws.
- c. Finish the installation by completely tightening the screws in the same sequence.

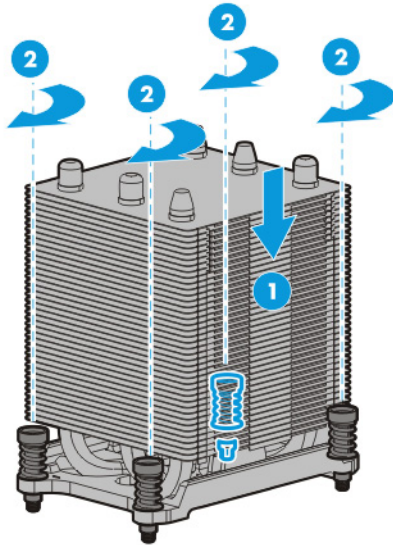

IMPORTANT: Install all components with the same configuration that was used on the failed system board.

10. Install all components removed from the failed system board.
11. Connect all cables disconnected from the failed system board.
12. Install the system air baffle.
13. If removed, install the PCI air baffle.
14. Install the access panel.
15. Return the server to an upright position.
16. Connect each power cord to the server.
17. Connect each power cord to the power source.
18. Power up the server.



IMPORTANT: Install all components with the same configuration that was used on the failed system board.

After you replace the system board, you must re-enter the server serial number and the product ID.

1. During the server startup sequence, press the **F9** key to access RBSU.
2. Select the **Advanced Options** menu.
3. Select **Service Options**.
4. Select **Serial Number**. The following warning appears:
Warning: The serial number should **ONLY** be modified by qualified service personnel. This value should always match the serial number located on the chassis.
5. Press the **Enter** key to clear the warning.
6. Enter the serial number and press the **Enter** key.

7. Select **Product ID**. The following warning appears:
Warning: The Product ID should ONLY be modified by qualified service personnel. This value should always match the Product ID located on the chassis.
8. Enter the product ID and press the **Enter** key.
9. Press the **Esc** key to close the menu.
10. Press the **Esc** key to exit RBSU.
11. Press the **F10** key to confirm exiting RBSU. The server automatically reboots.

System battery

If the server no longer automatically displays the correct date and time, then replace the battery that provides power to the real-time clock. Under normal use, battery life is 5 to 10 years.



WARNING: The computer contains an internal lithium manganese dioxide, a vanadium pentoxide, or an alkaline battery pack. A risk of fire and burns exists if the battery pack is not properly handled. To reduce the risk of personal injury:

- Do not attempt to recharge the battery.
 - Do not expose the battery to temperatures higher than 60°C (140°F).
 - Do not disassemble, crush, puncture, short external contacts, or dispose of in fire or water.
 - Replace only with the spare designated for this product.
-

To remove the component:

1. Power down the server (on page [25](#)).
2. Remove all power:
 - a. Disconnect each power cord from the power source.
 - b. Disconnect each power cord from the server.
3. Place the server on its side.
4. Remove the access panel (on page [25](#)).
5. If installed, remove the PCI air baffle (on page [27](#)).
6. Remove the system air baffle (on page [28](#)).
7. If installed, remove the HP Smart Storage Battery ("HP Smart Storage Battery" on page [42](#)).
8. Locate the battery on the system board ("System board components" on page [81](#)).

9. Remove the battery.

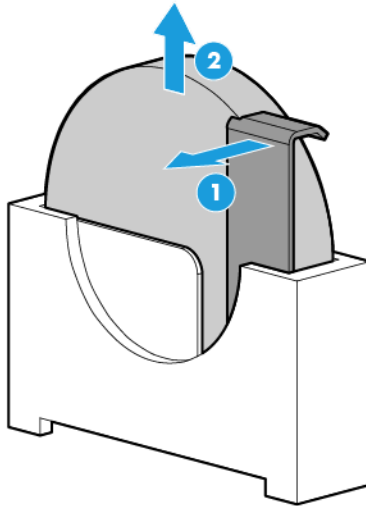

IMPORTANT: Replacing the system board battery resets the system ROM to its default configuration. After replacing the battery, reconfigure the system through RBSU.

To replace the component, reverse the removal procedure.

For more information about battery replacement or proper disposal, contact an authorized reseller or an authorized service provider.

Dedicated iLO port management module

To remove the component:

1. Power down the server (on page 25).
2. Remove all power:
 - a. Disconnect each power cord from the power source.
 - b. Disconnect each power cord from the server.
3. Place the server on its side.
4. Remove the access panel (on page 25).
5. If installed, remove the PCI air baffle (on page 27).
6. Remove the system air baffle (on page 28).

7. Open the slot cover and remove the Dedicated iLO port management module.

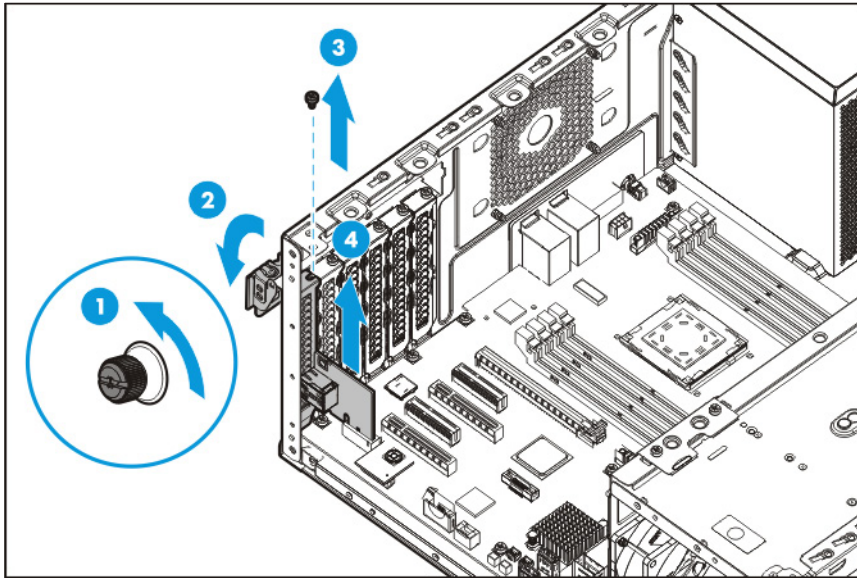

To replace the component, reverse the removal procedure. After installing the new dedicated iLO management module, enable the dedicated iLO connector ("[Enabling the dedicated iLO management module](#)" on page 60).

Enabling the dedicated iLO management module

The onboard NIC 1/shared iLO connector is set as the default system iLO connector. To enable the dedicated iLO management module, use the iLO 4 Configuration Utility accessible within the HP UEFI System Utilities.

For more information on the HP UEFI System Utilities, see the UEFI documentation on the HP website (<http://www.hp.com/go/ProLiantUEFI/docs>).



IMPORTANT: If the iLO configuration settings are reset to the default values, remote access to the machine will be lost. Access the physical machine and repeat the procedure described in this section to re-enable the dedicated iLO management connector.

To enable the dedicated iLO management module:

1. During the server startup sequence after installing the module, press **F9** in the POST screen.
The System Utilities screen appears.
2. Select **System Configuration | iLO 4 Configuration Utility**.
The iLO 4 Configuration Utility screen appears.
3. Select **Network Options**, and then press **Enter**.
The Network Options screen appears.
4. Set the **Network Interface Adapter** field to **ON**, and then press **Enter**.
5. Press **F10** to save your changes.
A message prompt to confirm the iLO settings reset appears.
6. Press **Enter** to reboot the iLO settings.
7. Press **Esc** until the main menu is displayed.

8. Select **Reboot the System** to exit the utility and resume the boot process.

The IP address of the enabled dedicated iLO connector appears on the POST screen on the subsequent boot-up. Access the Network Options screen again to view this IP address for later reference.

HP ATX 350-W Power Supply (non-hot-plug)

⚠ WARNING: To reduce the risk of personal injury from hot surfaces, allow the drives and the internal system components to cool before touching them.

⚠ CAUTION: To prevent damage to electrical components, take the appropriate anti-static precautions before beginning any installation, removal, or replacement procedure. Improper grounding can cause electrostatic discharge.

To remove the component:

1. Power down the server (on page 25).
2. Remove all power:
 - a. Disconnect each power cord from the power source.
 - b. Disconnect each power cord from the server.
3. Place the server on its side.
4. Remove the access panel (on page 25).
5. If installed, remove the PCI air baffle (on page 27).
6. Remove the system air baffle (on page 28).
7. Disconnect all power supply cables from the system board, drive cages, and devices.
8. Remove the non-hot-plug power supply.

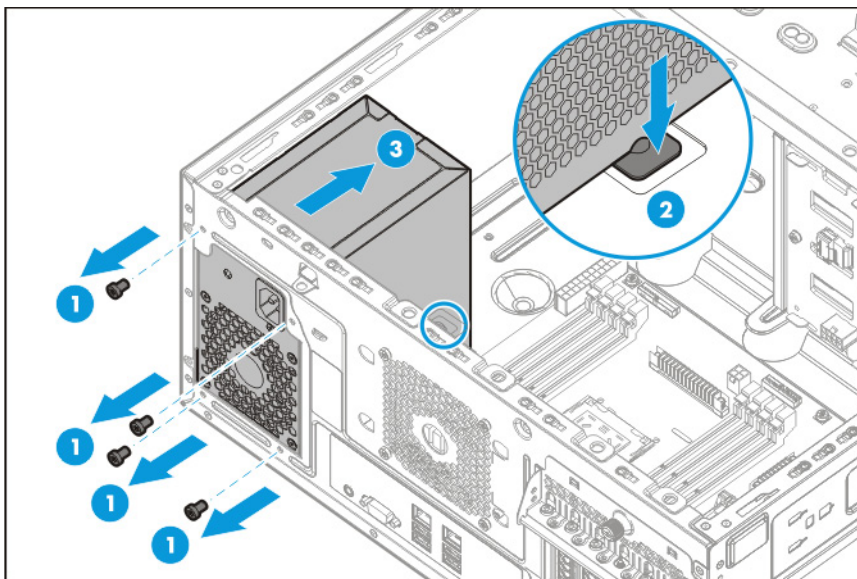

To replace the component, reverse the removal procedure.

HP ATX 550-W Power Supply (non-hot-plug)

-
- ⚠ WARNING:** To reduce the risk of personal injury from hot surfaces, allow the drives and the internal system components to cool before touching them.
-
- ⚠ CAUTION:** To prevent damage to electrical components, take the appropriate anti-static precautions before beginning any installation, removal, or replacement procedure. Improper grounding can cause electrostatic discharge.
-

To remove the component:

1. Power down the server (on page 25).
2. Remove all power:
 - a. Disconnect each power cord from the power source.
 - b. Disconnect each power cord from the server.
3. Place the server on its side.
4. Remove the access panel (on page 25).
5. If installed, remove the PCI air baffle (on page 27).
6. Remove the system air baffle (on page 28).
7. Disconnect all power supply cables from the system board, drive cages, and devices.
8. Remove the non-hot-plug power supply.

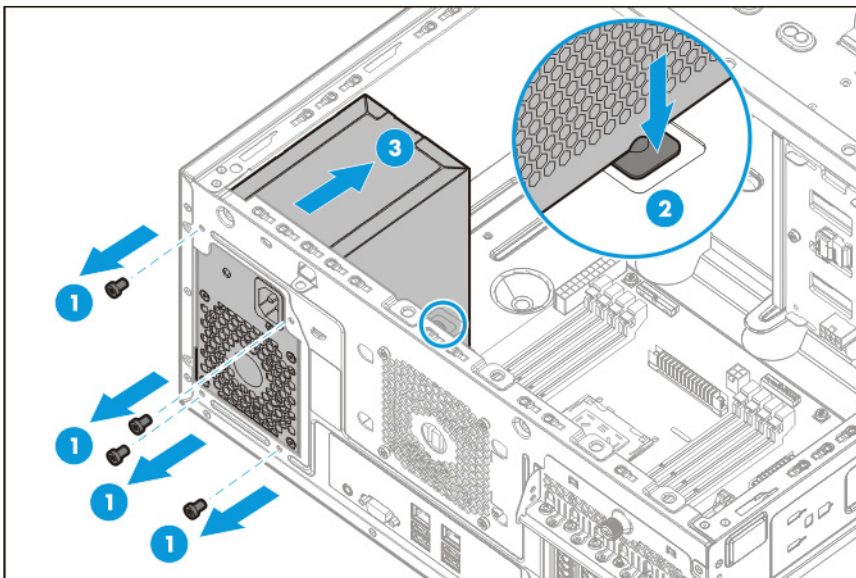

To replace the component, reverse the removal procedure.

RPS enablement kit



WARNING: To reduce the risk of electric shock or damage to the equipment:

- Do not disable the power cord grounding plug. The grounding plug is an important safety feature.
 - Plug the power cord into a grounded (earthed) electrical outlet that is easily accessible at all times.
 - Unplug the power cord from the power supply to disconnect power to the equipment.
 - Do not route the power cord where it can be walked on or pinched by items placed against it. Pay particular attention to the plug, electrical outlet, and the point where the cord extends from the equipment.
-



WARNING: To reduce the risk of injury from electric shock hazards, do not open power supplies. Refer all maintenance, upgrades, and servicing to qualified personnel.



WARNING: To reduce the risk of personal injury from hot surfaces, allow the drives and the internal system components to cool before touching them.



CAUTION: To prevent damage to electrical components, properly ground the server before beginning any installation procedure. Improper grounding can cause ESD.



CAUTION: To prevent improper cooling and thermal damage, do not operate the server unless all bays are populated with either a component or a blank.

To remove the component:

1. Power down the server (on page 25).
2. Release the power cord from the strain relief clip.

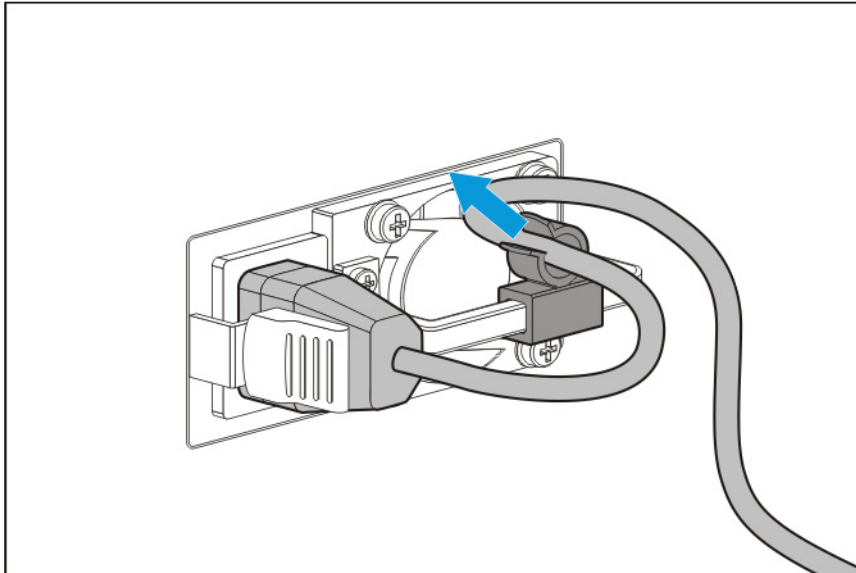

3. Remove the strain relief clip from RPS and retain the clip for future clip.

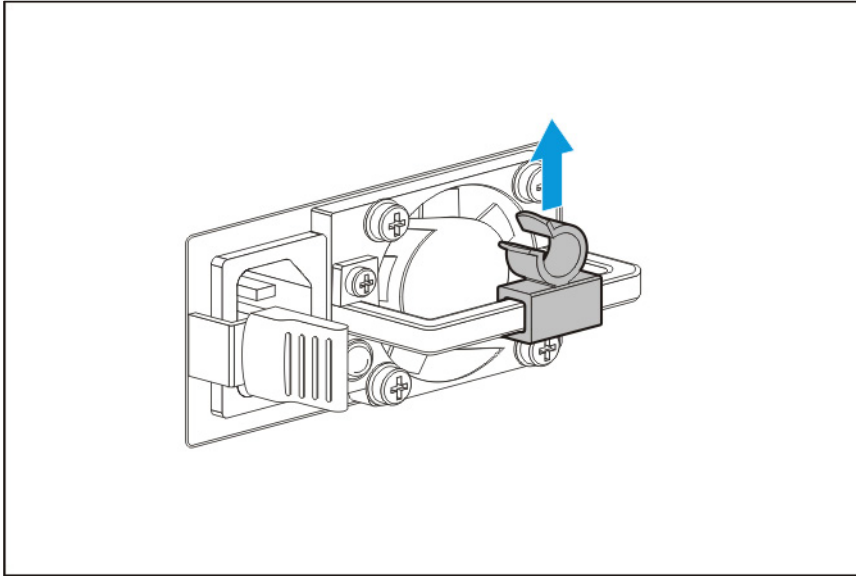

4. Remove all power:
 - a. Disconnect each power cord from the power source.
 - b. Disconnect each power cord from the server.
5. Place the server on a sturdy, level surface.
6. Remove the access panel (on page 25).
7. If installed, remove the PCI air baffle (on page 27).
8. Remove the system air baffle (on page 28).
9. Disconnect all power supply cables from the system board, drive cages, and devices.
10. Remove the hot-plug power input module.
11. Remove the RPS backplane.

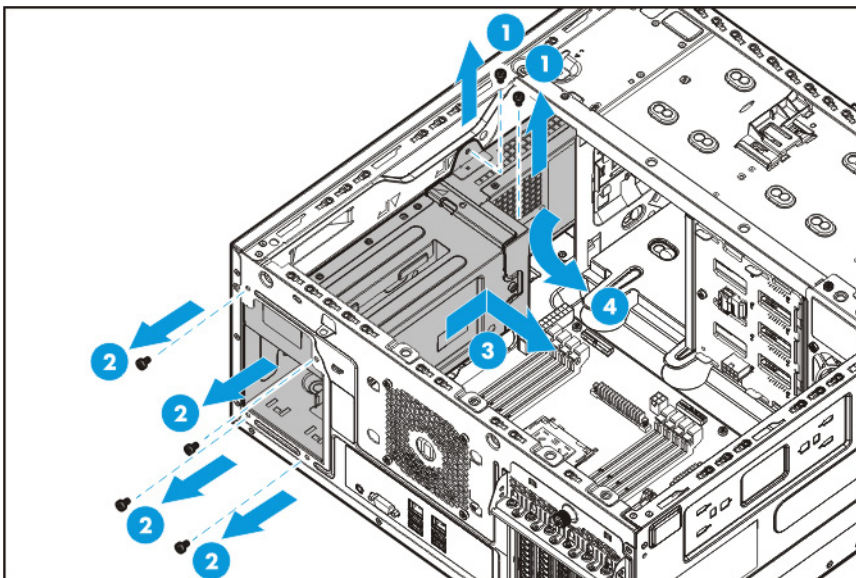

12. Remove the RPS bracket from the bay.

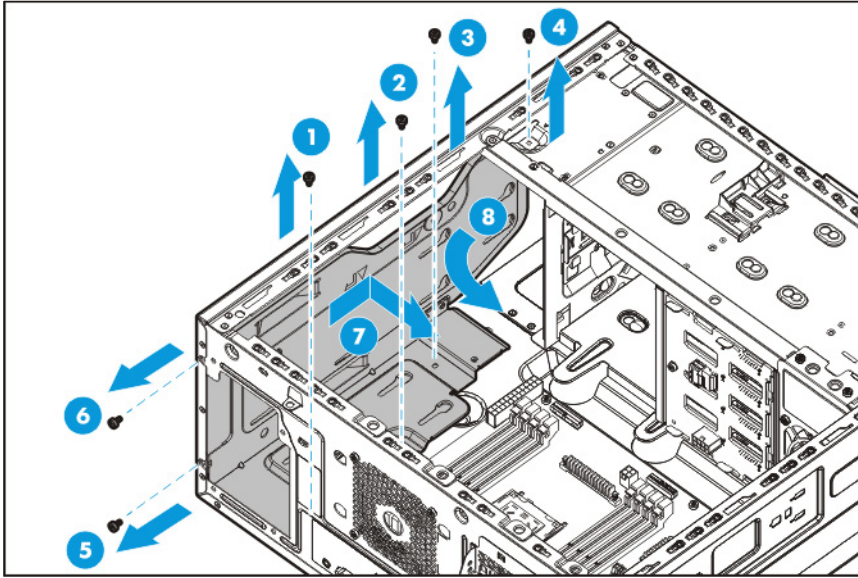

To replace the component, reverse the removal procedure.

HP redundant power supply input module

-
- WARNING:** To reduce the risk of electric shock or damage to the equipment:
 - Do not disable the power cord grounding plug. The grounding plug is an important safety feature.
 - Plug the power cord into a grounded (earthed) electrical outlet that is easily accessible at all times.
 - Unplug the power cord from the power supply to disconnect power to the equipment.
 - Do not route the power cord where it can be walked on or pinched by items placed against it. Pay particular attention to the plug, electrical outlet, and the point where the cord extends from the equipment.
-
- WARNING:** To reduce the risk of injury from electric shock hazards, do not open power supplies. Refer all maintenance, upgrades, and servicing to qualified personnel.
-
- WARNING:** To reduce the risk of personal injury from hot surfaces, allow the drives and the internal system components to cool before touching them.
-
- CAUTION:** To prevent damage to electrical components, properly ground the server before beginning any installation procedure. Improper grounding can cause ESD.
-
- CAUTION:** To prevent improper cooling and thermal damage, do not operate the server unless all bays are populated with either a component or a blank.
-

To remove the component:

1. Power down the server (on page 25).

2. Release the power cord from the strain relief clip.

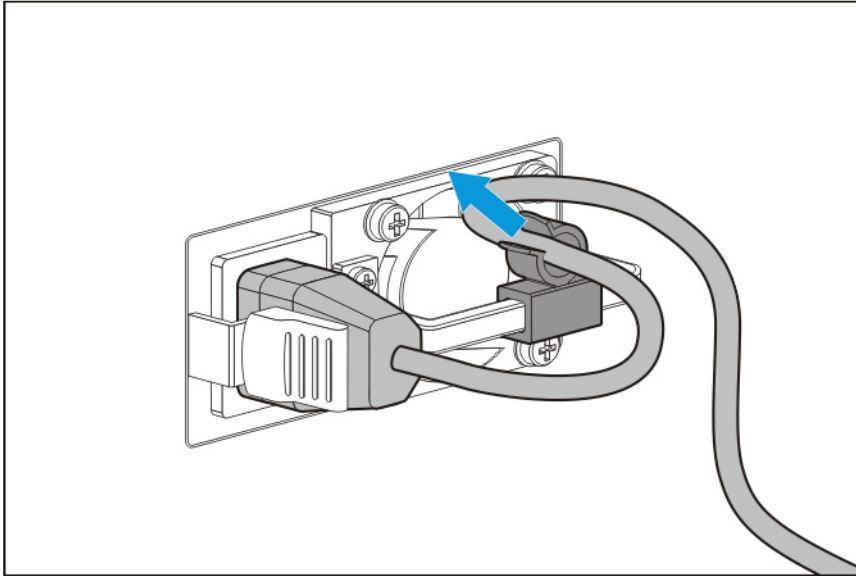

3. Remove the strain relief clip from RPS and retain the clip for future use.

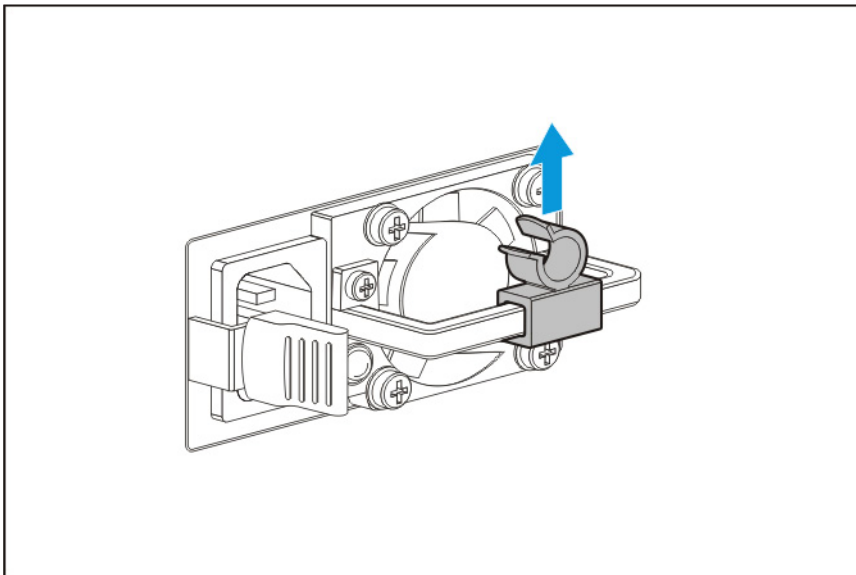

4. Remove all power:
 - a. Disconnect each power cord from the power source.
 - b. Disconnect each power cord from the server.
5. Place the server on a sturdy, level surface.
6. Remove the access panel (on page 25).
7. If installed, remove the PCI air baffle (on page 27).
8. Remove the system air baffle (on page 28).
9. Disconnect all power supply cables from the system board, drive cages, and devices.

10. Remove the hot-plug power input module from the power supply bay.

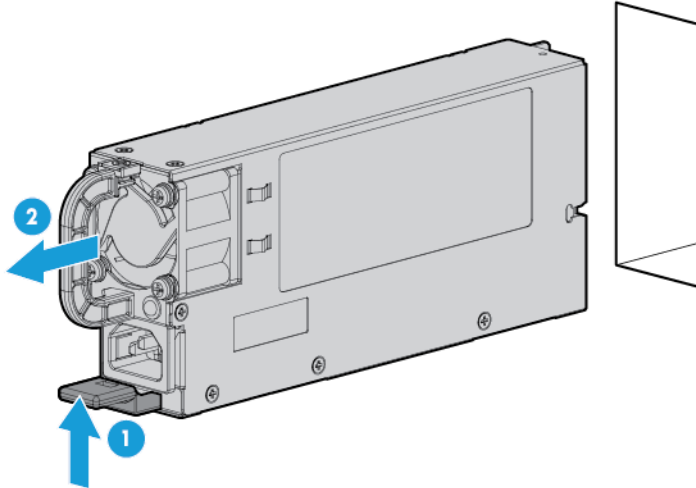

To replace the component, reverse the removal procedure.

Redundant power supply blank

- ⚠ **CAUTION:** To prevent improper cooling and thermal damage, do not operate the server unless all bays are populated with either a component or a blank.

To remove the component:

1. Power down the server (on page 25).
2. Access the product rear panel.

- ⚠ **WARNING:** To reduce the risk of personal injury from hot surfaces, allow the power supply or power supply blank to cool before touching it.

3. Remove the power supply blank.

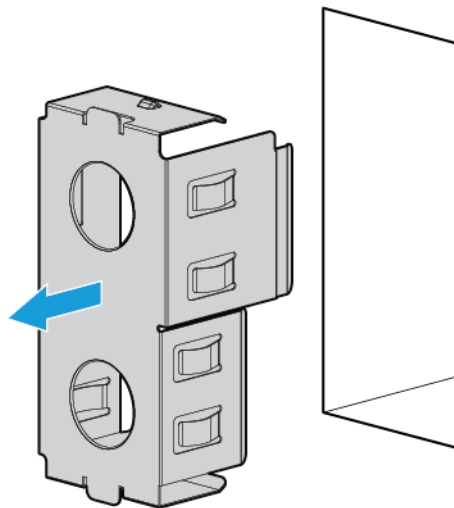

To replace the component, reverse the removal procedure.

HP Trusted Platform Module

The TPM is not a customer-removable part.



CAUTION: Any attempt to remove an installed TPM from the system board breaks or disfigures the TPM security rivet. Upon locating a broken or disfigured rivet on an installed TPM, administrators should consider the system compromised and take appropriate measures to ensure the integrity of the system data.

If you suspect a TPM board failure, leave the TPM installed and remove the system board. Contact an HP authorized service provider for a replacement system board and TPM board.

Troubleshooting

Troubleshooting resources

The *HP ProLiant Gen9 Troubleshooting Guide, Volume I: Troubleshooting* provides procedures for resolving common problems and comprehensive courses of action for fault isolation and identification, issue resolution, and software maintenance on ProLiant servers and server blades. To view the guide, select a language:

- English (http://www.hp.com/support/Gen9_TSG_en)
- French (http://www.hp.com/support/Gen9_TSG_fr)
- Spanish (http://www.hp.com/support/Gen9_TSG_es)
- German (http://www.hp.com/support/Gen9_TSG_de)
- Japanese (http://www.hp.com/support/Gen9_TSG_ja)
- Simplified Chinese (http://www.hp.com/support/Gen9_TSG_zh_cn)

The *HP ProLiant Gen9 Troubleshooting Guide, Volume II: Error Messages* provides a list of error messages and information to assist with interpreting and resolving error messages on ProLiant servers and server blades. To view the guide, select a language:

- English (http://www.hp.com/support/Gen9_EMG_en)
- French (http://www.hp.com/support/Gen9_EMG_fr)
- Spanish (http://www.hp.com/support/Gen9_EMG_es)
- German (http://www.hp.com/support/Gen9_EMG_de)
- Japanese (http://www.hp.com/support/Gen9_EMG_ja)
- Simplified Chinese (http://www.hp.com/support/Gen9_EMG_zh_cn)

Diagnostic tools

Product QuickSpecs

For more information about product features, specifications, options, configurations, and compatibility, see the product QuickSpecs on the HP website (<http://www.hp.com/go/qs>).

HP iLO

The iLO 4 subsystem is a standard component of HP ProLiant servers that simplifies initial server setup, server health monitoring, power and thermal optimization, and remote server administration. The iLO 4 subsystem includes an intelligent microprocessor, secure memory, and a dedicated network interface. This design makes iLO 4 independent of the host server and its operating system.

iLO 4 enables and manages the Active Health System (on page 71) and also features Agentless Management. All key internal subsystems are monitored by iLO 4. If enabled, SNMP alerts are sent directly by iLO 4 regardless of the host operating system or even if no host operating system is installed.

Embedded remote support software is available on HP ProLiant Gen8 and later servers with iLO 4, regardless of the operating system software and without installing OS agents on the server.

Using iLO 4, you can do the following:

- Access a high-performance and secure Integrated Remote Console to the server from anywhere in the world if you have a network connection to the server.
- Use the shared .NET Integrated Remote Console to collaborate with up to four server administrators.
- Remotely mount high-performance Virtual Media devices to the server.
- Securely and remotely control the power state of the managed server.
- Implement true Agentless Management with SNMP alerts from HP iLO, regardless of the state of the host server.
- Download the Active Health System log.
- Register for HP Insight Remote Support.
- Use iLO Federation to manage multiple servers from one system running the iLO web interface.
- Use Virtual Power and Virtual Media from the GUI, the CLI, or the iLO scripting toolkit for many tasks, including the automation of deployment and provisioning.
- Control iLO by using a remote management tool.

For more information about iLO 4 features, see the iLO 4 documentation on the HP website (<http://www.hp.com/go/ilo/docs>).

The HP iLO 4 hardware and firmware features and functionality, such as NAND size and embedded user partition, vary depending on the server model. For a complete list of supported features and functionality, see the HP iLO 4 QuickSpecs on the HP website (http://h18000.www1.hp.com/products/quickspecs/14276_div/14276_div.pdf).

Active Health System

HP Active Health System provides the following features:

- Combined diagnostics tools/scanners
- Always on, continuous monitoring for increased stability and shorter downtimes
- Rich configuration history
- Health and service alerts
- Easy export and upload to Service and Support

The HP Active Health System monitors and records changes in the server hardware and system configuration. The Active Health System assists in diagnosing problems and delivering rapid resolution if server failures occur.

The Active Health System collects the following types of data:

- Server model
- Serial number
- Processor model and speed
- Storage capacity and speed
- Memory capacity and speed
- Firmware/BIOS

HP Active Health System does not collect information about Active Health System users' operations, finances, customers, employees, partners, or data center, such as IP addresses, host names, user names, and passwords. HP Active Health System does not parse or change operating system data from third-party error event log activities, such as content created or passed through by the operating system.

The data that is collected is managed according to the HP Data Privacy policy. For more information see the HP website (<http://www.hp.com/go/privacy>).

The Active Health System, in conjunction with the system monitoring provided by Agentless Management or SNMP Pass-thru, provides continuous monitoring of hardware and configuration changes, system status, and service alerts for various server components.

The Agentless Management Service is available in the SPP, which can be downloaded from the HP website (<http://www.hp.com/go/spp/download>). The Active Health System log can be downloaded manually from iLO 4 or HP Intelligent Provisioning and sent to HP.

For more information, see the following documents:

- *HP iLO User Guide* on the HP website (<http://www.hp.com/go/ilo/docs>)
- *HP Intelligent Provisioning User Guide* on the HP website (<http://www.hp.com/go/intelligentprovisioning/docs>)

HP ProLiant Pre-boot Health Summary

If the server will not start up, you can use iLO 4 to display diagnostic information on an external monitor. This feature is supported on servers that support external video and have a UID button or an SUV connector. When power is available to the server but the server is not powered on, iLO runs on auxiliary power and can take control of the server video adapter to display the HP ProLiant Pre-boot Health Summary.

For additional information, see the following documents:

- *HP iLO 4 User Guide* — See the HP website (<http://www.hp.com/go/ilo/docs>).
- *HP ProLiant Gen9 Troubleshooting Guide, Volume I: Troubleshooting* — See "Troubleshooting Resources (on page 69)."

Integrated Management Log

The IML records hundreds of events and stores them in an easy-to-view form. The IML timestamps each event with 1-minute granularity.

You can view recorded events in the IML in several ways, including the following:

- From within HP SIM
- From within HP UEFI System Utilities (on page 72)
- From within the Embedded UEFI shell
- From within operating system-specific IML viewers:
 - For Windows: IML Viewer
 - For Linux: IML Viewer Application
- From within the iLO 4 web interface
- From within HP Insight Diagnostics (on page 74)

HP UEFI System Utilities

The HP UEFI System Utilities is embedded in the system ROM. The UEFI System Utilities enable you to perform a wide range of configuration activities, including:

- Configuring system devices and installed options
- Enabling and disabling system features
- Displaying system information
- Selecting the primary boot controller
- Configuring memory options
- Selecting a language
- Launching other pre-boot environments such as the Embedded UEFI Shell and Intelligent Provisioning

For more information on the HP UEFI System Utilities, see the *HP UEFI System Utilities User Guide for HP ProLiant Gen9 Servers* on the HP website (<http://www.hp.com/go/ProLiantUEFI/docs>).

Scan the QR code located at the bottom of the screen to access mobile-ready online help for the UEFI System Utilities and UEFI Shell. For on-screen help, press **F1**.

Using HP UEFI System Utilities

To use the System Utilities, use the following keys.

Action	Key
Access System Utilities	F9 during server POST

Action	Key
Navigate menus	Up and Down arrows
Select items	Enter
Save selections	F10
Access Help for a highlighted configuration option*	F1

*Scan the QR code on the screen to access online help for the UEFI System Utilities and UEFI Shell.

Default configuration settings are applied to the server at one of the following times:

- Upon the first system power-up
- After defaults have been restored

Default configuration settings are sufficient for typical server operations; however, you can modify configuration settings as needed. The system prompts you for access to the System Utilities each time the system is powered up.

Embedded Diagnostics option

The system BIOS in all HP ProLiant Gen9 servers includes an Embedded Diagnostics option in the ROM. The Embedded Diagnostics option can run comprehensive diagnostics of the server hardware, including processors, memory, drives, and other server components.

For more information on the Embedded Diagnostics option, see the *HP UEFI System Utilities User Guide for HP ProLiant Gen9 Servers* on the HP website (<http://www.hp.com/go/ProLiantUEFI/docs>).

Re-entering the server serial number and product ID

After you replace the system board, you must re-enter the server serial number and the product ID.

1. During the server startup sequence, press the **F9** key to access UEFI System Utilities.
2. Select the **System Configuration > BIOS/Platform Configuration (RBSU) > Advanced Options > Advanced System ROM Options > Serial Number**, and then press the **Enter** key.
3. Enter the serial number and press the **Enter** key. The following message appears:

```
The serial number should only be modified by qualified service personnel.
This value should always match the serial number located on the chassis.
```
4. Press the **Enter** key to clear the warning.
5. Enter the serial number and press the **Enter** key.
6. Select **Product ID**. The following warning appears:

```
Warning: The Product ID should ONLY be modified by qualified service
personnel. This value should always match the Product ID located on the
chassis.
```
7. Enter the product ID and press the **Enter** key.
8. Press the **F10** key to confirm exiting System Utilities. The server automatically reboots.

HP Insight Diagnostics

HP Insight Diagnostics is a proactive server management tool, available in both offline and online versions, that provides diagnostics and troubleshooting capabilities to assist IT administrators who verify server installations, troubleshoot problems, and perform repair validation.

HP Insight Diagnostics Offline Edition performs various in-depth system and component testing while the OS is not running. To run this utility, boot the server using Intelligent Provisioning.

HP Insight Diagnostics Online Edition is a web-based application that captures system configuration and other related data needed for effective server management. Available in Microsoft Windows and Linux versions, the utility helps to ensure proper system operation.

For more information or to download the utility, see the HP website (<http://www.hp.com/servers/diags>). HP Insight Diagnostics Online Edition is also available in the SPP.

HP Insight Diagnostics survey functionality

HP Insight Diagnostics (on page 74) provides survey functionality that gathers critical hardware and software information on ProLiant servers.

This functionality supports operating systems that are supported by the server. For operating systems supported by the server, see the HP website (<http://www.hp.com/go/supportos>).

If a significant change occurs between data-gathering intervals, the survey function marks the previous information and overwrites the survey data files to reflect the latest changes in the configuration.

Survey functionality is installed with every Intelligent Provisioning-assisted HP Insight Diagnostics installation, or it can be installed through the SPP.

HP Insight Remote Support

HP strongly recommends that you register your device for remote support to enable enhanced delivery of your HP Warranty, HP Care Pack Service, or HP contractual support agreement. HP Insight Remote Support supplements your monitoring continuously to ensure maximum system availability by providing intelligent event diagnosis, and automatic, secure submission of hardware event notifications to HP, which will initiate a fast and accurate resolution, based on your product's service level. Notifications can be sent to your authorized HP Channel Partner for onsite service, if configured and available in your country.

For more information, see *HP Insight Remote Support and Insight Online Setup Guide for ProLiant Servers and BladeSystem c-Class Enclosures* on the HP website (<http://www.hp.com/go/insightremotesupport/docs>). HP Insight Remote Support is available as part of HP Warranty, HP Care Pack Service, or HP contractual support agreement.

USB support

HP servers support both USB 2.0 ports and USB 3.0 ports. Both types of ports support installing all types of USB devices (USB 1.0, USB 2.0, and USB 3.0), but may run at lower speeds in specific situations:

- USB 3.0 capable devices operate at USB 2.0 speeds when installed in a USB 2.0 port.
- When the server is configured for UEFI Boot Mode, HP provides legacy USB support in the pre-boot environment prior to the operating system loading for USB 1.0, USB 2.0, and USB 3.0 speeds.

- When the server is configured for Legacy BIOS Boot Mode, HP provides legacy USB support in the pre-boot environment prior to the operating system loading for USB 1.0 and USB 2.0 speeds. While USB 3.0 ports can be used with all devices in Legacy BIOS Boot Mode, they are not available at USB 3.0 speeds in the pre-boot environment. Standard USB support (USB support from within the operating system) is provided by the OS through the appropriate USB device drivers. Support for USB 3.0 varies by operating system.

For maximum compatibility of USB 3.0 devices with all operating systems, HP provides a configuration setting for USB 3.0 Mode. Auto is the default setting. This setting impacts USB 3.0 devices when connected to USB 3.0 ports in the following manner:

- **Auto (default)**—If configured in Auto Mode, USB 3.0 capable devices operate at USB 2.0 speeds in the pre-boot environment and during boot. When a USB 3.0 capable OS USB driver loads, USB 3.0 devices transition to USB 3.0 speeds. This mode provides compatibility with operating systems that do not support USB 3.0 while still allowing USB 3.0 devices to operate at USB 3.0 speeds with state-of-the-art operating systems.
- **Enabled**—If Enabled, USB 3.0 capable devices operate at USB 3.0 speeds at all times (including the pre-boot environment) when in UEFI Boot Mode. This mode should not be used with operating systems that do not support USB 3.0. If operating in Legacy Boot BIOS Mode, the USB 3.0 ports cannot function in the pre-boot environment and are not bootable.
- **Disabled**—If configured for Disabled, USB 3.0 capable devices function at USB 2.0 speeds at all times.

The pre-OS behavior of the USB ports is configurable in System Utilities, so that the user can change the default operation of the USB ports. For more information, see the *HP UEFI System Utilities User Guide for HP ProLiant Gen9 Servers* on the HP website (<http://www.hp.com/go/ProLiantUEFI/docs>).

External USB functionality

HP provides external USB support to enable local connection of USB devices for server administration, configuration, and diagnostic procedures.

For additional security, external USB functionality can be disabled through USB options in UEFI System Utilities.

HP Smart Storage Administrator

HP SSA is a configuration and management tool for HP Smart Array controllers. Starting with HP ProLiant Gen8 servers, HP SSA replaces ACU with an enhanced GUI and additional configuration features.

HP SSA exists in three interface formats: the HP SSA GUI, the HP SSA CLI, and HP SSA Scripting. Although all formats provide support for configuration tasks, some of the advanced tasks are available in only one format.

Some HP SSA features include the following:

- Supports online array capacity expansion, logical drive extension, assignment of online spares, and RAID or stripe size migration
- Suggests the optimal configuration for an unconfigured system
- Provides diagnostic and SmartSSD Wear Gauge functionality on the Diagnostics tab
- For supported controllers, provides access to additional features.

For more information about HP SSA, see the HP website (<http://www.hp.com/go/hpssa>).

Automatic Server Recovery

ASR is a feature that causes the system to restart when a catastrophic operating system error occurs, such as a blue screen, ABEND (does not apply to HP ProLiant DL980 Servers), or panic. A system fail-safe timer, the ASR timer, starts when the System Management driver, also known as the Health Driver, is loaded. When the operating system is functioning properly, the system periodically resets the timer. However, when the operating system fails, the timer expires and restarts the server.

ASR increases server availability by restarting the server within a specified time after a system hang. At the same time, the HP SIM console notifies you by sending a message to a designated pager number that ASR has restarted the system. You can disable ASR from the System Management Homepage or through RBSU.

Component identification

Front panel components

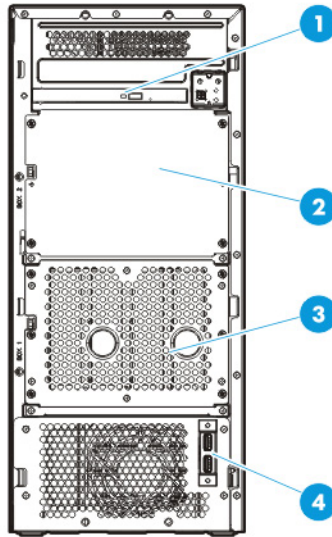

Item	Description
1	Optical drive (optional)
2	Box 2
3	Box 1
4	USB 3.0 connectors

Front panel LEDs and buttons

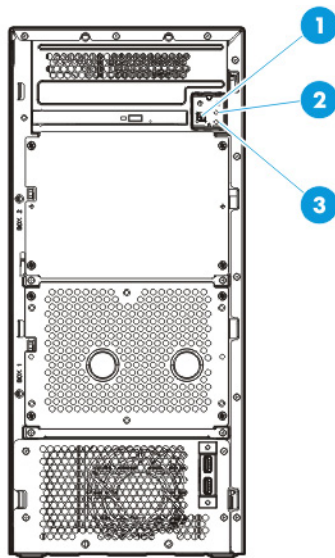

Item	Description	Status
1	Power On/Standby button and system power LED*	Solid green = System on Flashing green (1 Hz/cycle per sec) = Performing power on sequence Solid amber = System in standby Off = No power present**
2	Health LED*	Solid green = Normal Flashing green (1 Hz/cycle per sec) = iLO is rebooting. Flashing amber = System degraded† Flashing red (1 Hz/cycle per sec) = System critical†
3	NIC status LED*	Solid green = Link to network Flashing green (1 Hz/cycle per sec) = Network active Off = No network activity

* When all three LEDs described in this table and the UID button/LED on the rear panel flash simultaneously, a power fault has occurred. For more information, see "Front panel LED power fault codes (on page 78)." For the location of the UID button/LED on the rear panel, see "Rear panel LEDs (on page 80)".

** Facility power is not present, power cord is not attached, no power supplies are installed, power supply failure has occurred, or the power button cable is disconnected.

† If the health LED indicates a degraded or critical state, review the system IML or use iLO to review the system health status.

Front panel LED power fault codes

The following table provides a list of power fault codes, and the subsystems that are affected. Not all power faults are used by all servers.

Subsystem	Front panel LED behavior
System board	1 flash
Processor	2 flashes
Memory	3 flashes
Riser board PCIe slots	4 flashes
FlexibleLOM	5 flashes

Subsystem	Front panel LED behavior
Removable HP Flexible Smart Array controller/Smart SAS HBA controller	6 flashes
System board PCIe slots	7 flashes
Power backplane or storage backplane	8 flashes
Power supply	9 flashes

For more information, see "Front panel LEDs and buttons (on page 78)."

Rear panel components

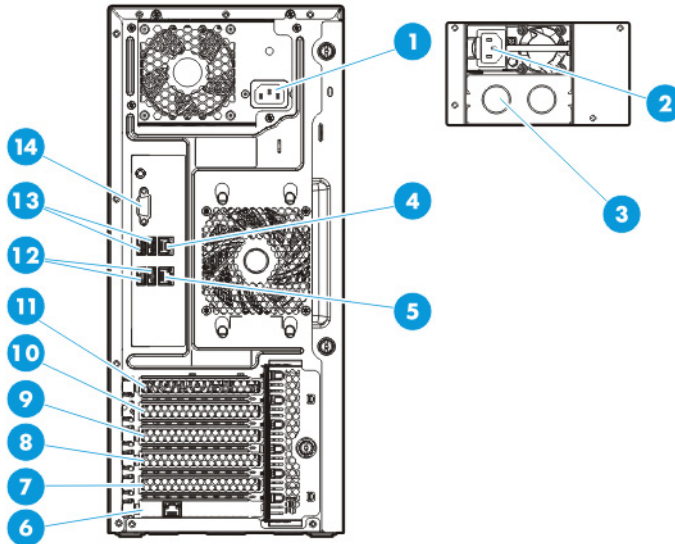

Item	Description
1	Non-hot-plug power supply
2	Power supply bay 1 of the hot-plug power supply (optional)
3	Power supply bay 2 of the hot-plug power supply (optional)
4	NIC connector 1
5	NIC connector 2
6	Dedicated iLO port (optional)
7	Slot 5 PCIe3x8 (8, 4, 1)
8	Slot 4 PCIe3x4 (4, 1)
9	Slot 3 PCIe3x8 (8, 4, 1)
10	Slot 2 PCIe3x4 (4, 1)
11	Slot 1 PCIe3x16 (16, 8, 4, 1)
12	USB 2.0 connectors
13	USB 3.0 connectors
14	Video connector

Rear panel LEDs

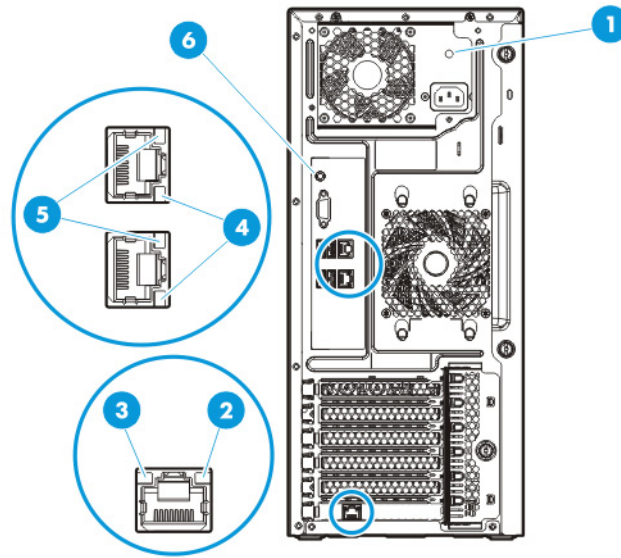

Item	Description	Status
1	Power supply LED	Solid green = Normal Off = One or more of the following conditions exists: <ul style="list-style-type: none"> • Power is unavailable • Power supply failed • Power supply is in standby mode • Power supply error
2	iLO link LED	Green = Linked to network Off = No network connection
3	iLO activity LED	Green or flashing green = Network activity Off = No network activity
4	NIC activity LED	Green or flashing green = Network activity Off = No network activity
5	NIC link LED	Green = Linked to network Off = No network connection
6	UID button/LED	Solid blue = Activated Flashing blue: <ul style="list-style-type: none"> • 1 Hz/cycle per sec = Remote management or firmware upgrade in progress • 4 Hz/cycle per sec = iLO manual reboot sequence initiated • 8 Hz/cycle per sec = iLO manual reboot sequence in progress Off = Deactivated

System board components

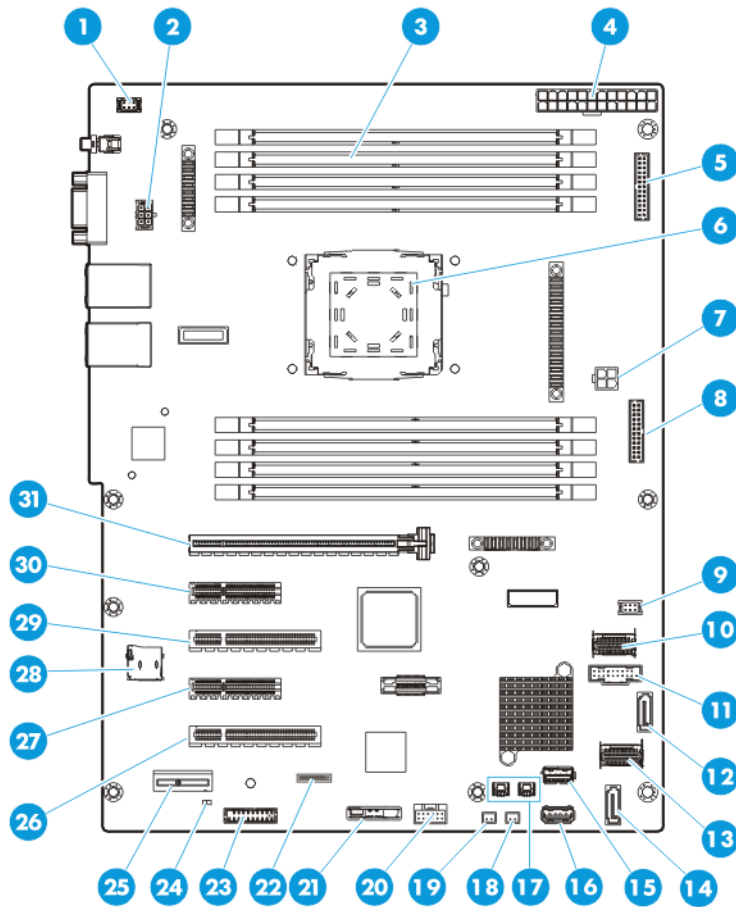

Item	Description
1	Fan connector 3
2	Fan connector 2
3	DIMM slots
4	24-pin power supply connector
5	RPSU connector
6	Processor
7	4-pin power supply connector
8	Front I/O connector
9	Fan connector 1
10	Mini-SAS connector 1
11	Front USB 3.0 connector
12	SATA connector 2
13	Mini-SAS connector 2
14	SATA connector 1
15	Internal USB 3.0 connector
16	Internal USB 2.0 connector
17	Storage backup power connector
18	Hard drive power good cable connector 2

Item	Description
19	Hard drive power good cable connector 1
20	HP Smart Storage Battery connector
21	System battery
22	System maintenance switch
23	TPM connector
24	NMI header
25	Dedicated iLO port connector
26	Slot 5 PCIe3 x8 (8, 4, 1)
27	Slot 4 PCIe3 x4 (4, 1)
28	microSD slot
29	Slot 3 PCIe3 x8 (8, 4, 1)
30	Slot 2 PCIe3 x4 (4, 1)
31	Slot 1 PCIe3 x16 (16, 8, 4, 1)

System maintenance switch

Position	Default	Function
S1	Off	Off = iLO 4 security is enabled. On = iLO 4 security is disabled.
S2	Off	Off = System configuration can be changed. On = System configuration is locked.
S3	Off	Reserved
S4	Off	Reserved
S5	Off	Off = Power-on password is enabled. On = Power-on password is disabled.
S6	Off	Off = No function On = ROM reads system configuration as invalid.
S7	Off	Off = Set default boot mode to UEFI. On = Set default boot mode to legacy.
S8	—	Reserved
S9	—	Reserved
S10	—	Reserved
S11	—	Reserved
S12	—	Reserved

To access the redundant ROM, set S1, S5, and S6 to on.

When the system maintenance switch position 6 is set to the On position, the system is prepared to erase all system configuration settings from both CMOS and NVRAM.



CAUTION: Clearing CMOS and/or NVRAM deletes configuration information. Be sure to properly configure the server or data loss could occur.



IMPORTANT: Before using the S7 switch to change to Legacy BIOS Boot Mode, be sure the HP Dynamic Smart Array B140i Controller is disabled. Do not use the B140i controller when the server is in Legacy BIOS Boot Mode.

NMI functionality

An NMI crash dump creates a crash dump log before resetting a system which is not responding.

Crash dump log analysis is an essential part of diagnosing reliability problems, such as failures of operating systems, device drivers, and applications. Many crashes freeze a system, and the only available action for administrators is to restart the system. Resetting the system erases any information which could support problem analysis, but the NMI feature preserves that information by performing a memory dump before a system reset.

To force the system to invoke the NMI handler and generate a crash dump log, do one of the following:

- Use the iLO Virtual NMI feature.
- Short the NMI header ("System board components" on page 81).

For more information, see the HP website (<http://www.hp.com/support/NMI>).

DIMM slot locations

DIMM slots are numbered sequentially (1 through 8) for the processor. The supported AMP modes use the letter assignments for population guidelines.

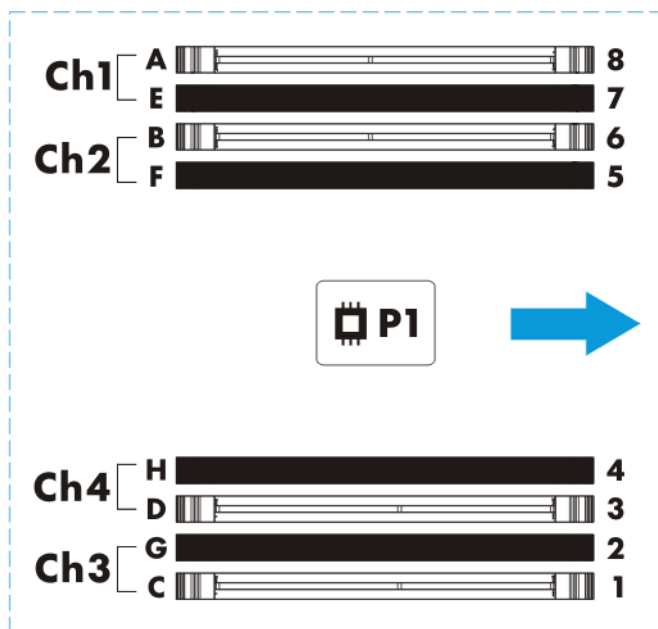

The arrow points to the front of the server.

Fan locations

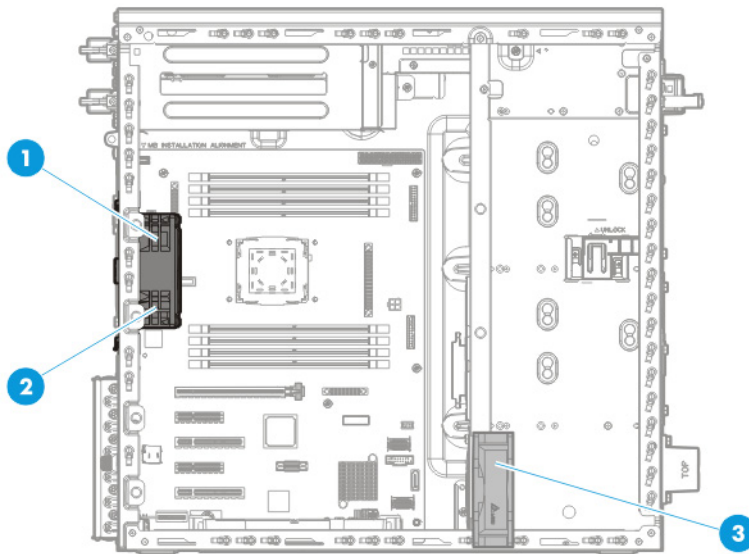

Item	Description
1	Default system fan (92 x 32 mm)
2	Upgrade system fan (92 x 38 mm) (this option is required to replace the default system fan when a 140-W workstation processor or SAS SSD drives are installed in the server.)
3	PCI fan

Drive numbering

The following images show the drive numbering for each of the supported drive configurations. For drive box numbering information, see "Front panel components (on page 77)."

With optional drive cages installed, the server supports up to 4 LFF non-hot-plug drives, 8 LFF hot-plug drives or 16 SFF hot-plug drives. If only one drive cage is installed, it must be installed in box 1. The server does not support mixing SFF and LFF drives.

HP recommends that you populate drive bays starting with the lowest drive number. Drives are numbered from left to right in each component box.

- Four-bay LFF non-hot-plug drive model

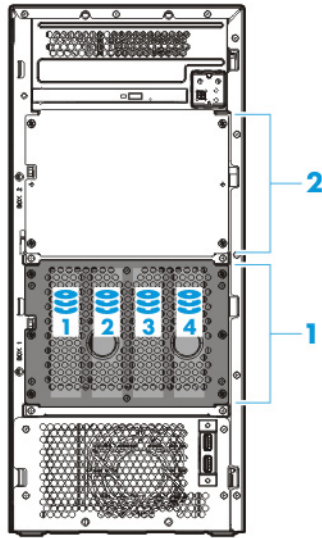

- Four-bay LFF hot-plug drive model

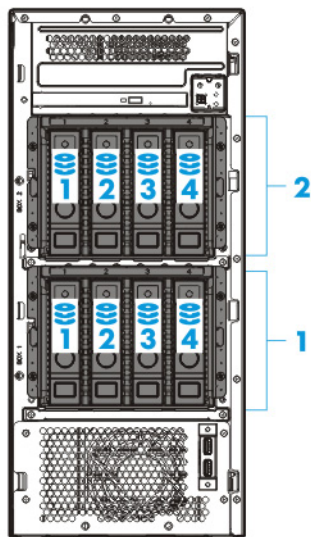

- Eight-bay SFF hot-plug drive model

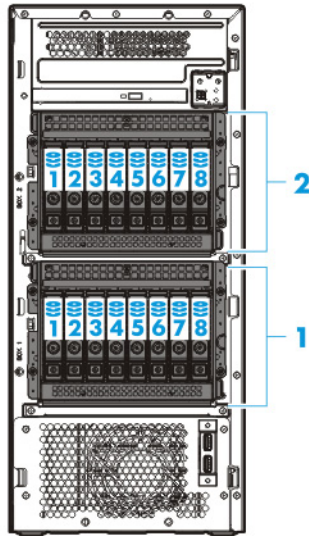

HP SmartDrive LED definitions

HP SmartDrives are the latest HP drive technology, and they are supported beginning with ProLiant Gen8 servers and server blades. The HP SmartDrive is not supported on earlier generation servers and server blades. Identify an HP SmartDrive by its carrier, shown in the following illustration.

When a drive is configured as a part of an array and connected to a powered-up controller, the drive LEDs indicate the condition of the drive.

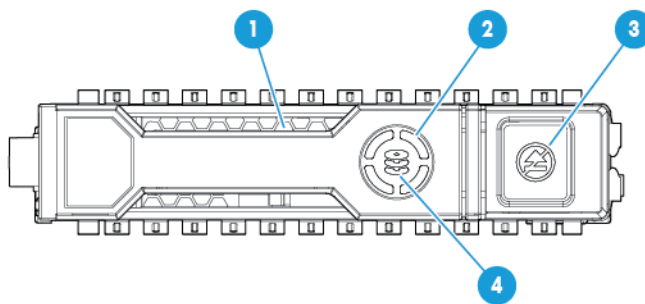

Item	LED	Status	Definition
1	Locate	Solid blue	The drive is being identified by a host application.
		Flashing blue	The drive carrier firmware is being updated or requires an update.
2	Activity ring	Rotating green	Drive activity
		Off	No drive activity
3	Do not remove	Solid white	Do not remove the drive. Removing the drive causes one or more of the logical drives to fail.
		Off	Removing the drive does not cause a logical drive to fail.
4	Drive status	Solid green	The drive is a member of one or more logical drives.

Item	LED	Status	Definition
		Flashing green	The drive is rebuilding or performing a RAID migration, strip size migration, capacity expansion, or logical drive extension, or is erasing.
		Flashing amber/green	The drive is a member of one or more logical drives and predicts the drive will fail.
		Flashing amber	The drive is not configured and predicts the drive will fail.
		Solid amber	The drive has failed.
		Off	The drive is not configured by a RAID controller.

The blue Locate LED is behind the release lever and is visible when illuminated.



IMPORTANT: The HP Dynamic Smart Array B140i Controller is only available in UEFI Boot Mode. It cannot be enabled in Legacy BIOS Boot Mode. If the B140i controller is disabled, drives connected to the system board Mini-SAS connectors operate in AHCI or Legacy mode. Under this condition:

- The drives cannot be a part of a hardware RAID or a logical drive.
- The Locate, Drive status, and Do not remove LEDs of the affected drives are disabled.

Use BIOS/Platform Configuration (RBSU) in the UEFI System Utilities ("[HP UEFI System Utilities](#)" on page 72) to enable or disable the B140i controller (System Configuration → BIOS/Platform Configuration (RBSU) → System Options → SATA Controller Options → Embedded SATA Configuration).

Cabling

Cabling overview

This section provides guidelines that help you make informed decisions about cabling the server and hardware options to optimize performance.

For information on cabling peripheral components, refer to the white paper on high-density deployment at the HP website (<http://www.hp.com/products/servers/platforms>).

CAUTION: When routing cables, always be sure that the cables are not in a position where they can be pinched or crimped.

Storage cabling

4-bay LFF non-hot-plug drive cabling

- Box 1

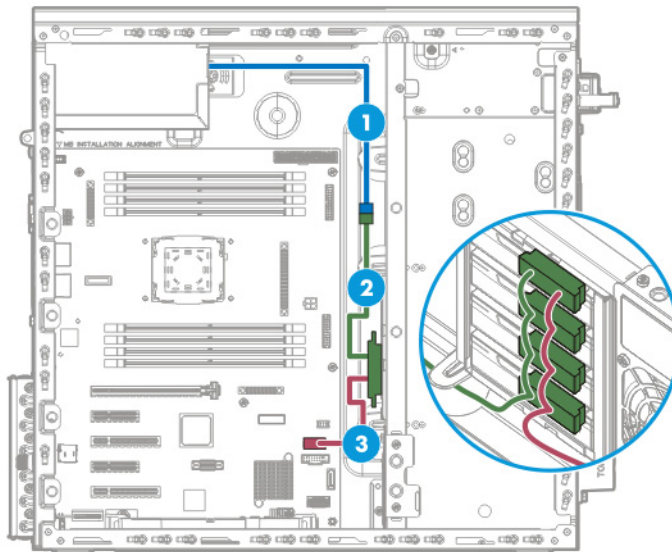

Item	Description
1	Power supply cable
2	Box 1 drive power cable
3	Mini-SAS cable

4-bay LFF hot-plug drive cabling

- Box 1 drive backplane connected to the system board

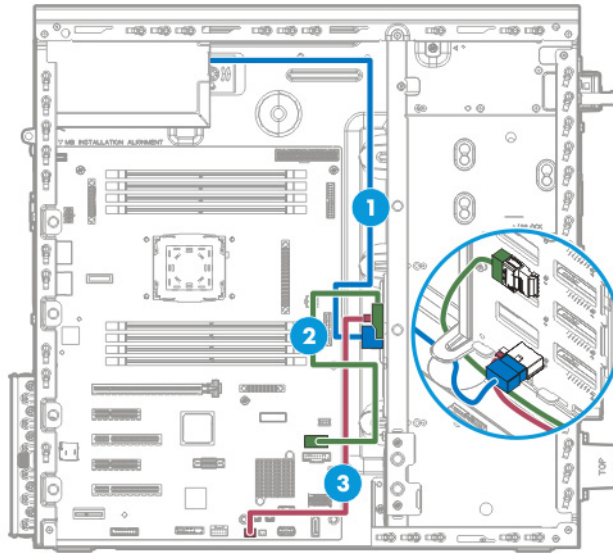

Item	Description
1	Drive power cable
2	Mini-SAS cable
3	Hard drive power good cable

- Box 2 drive backplane connected the system board

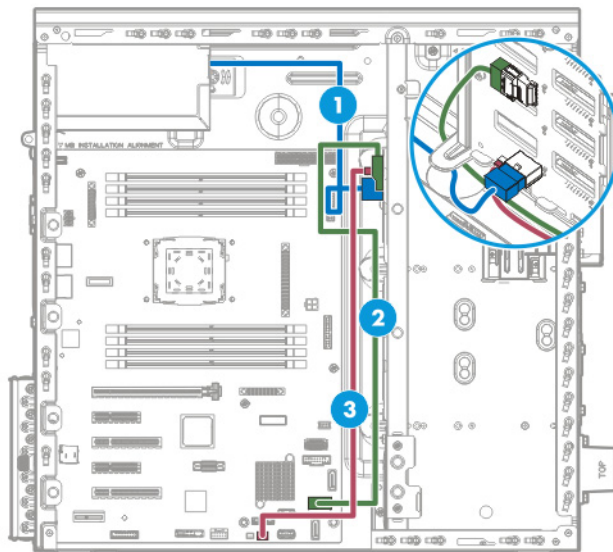

Item	Description
1	Drive power cable
2	Mini-SAS cable
3	Hard drive power good cable

- Box 1 and box 2 drive backplanes connected to a H240 adapter

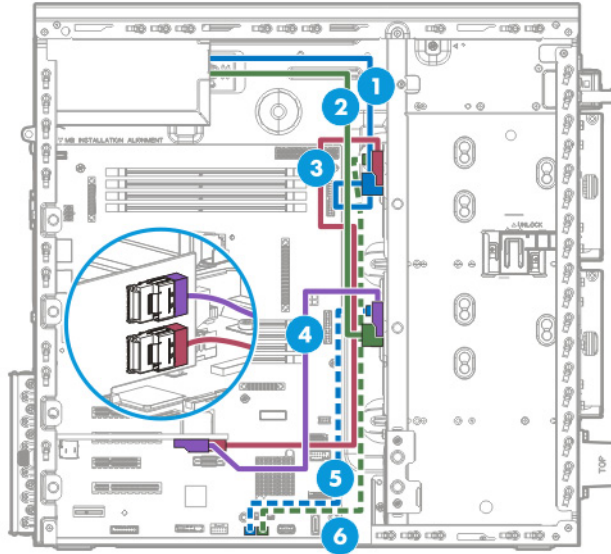

Item	Description
1	Box 2 drive power cable
2	Box 1 drive power cable
3	Mini-SAS cable to port 2 of the controller
4	Mini-SAS cable to port 1 of the controller
5	Box 1 hard drive power good cable
6	Box 2 hard drive power good cable

- Box 1 and box 2 drive backplanes connected to a P440 controller

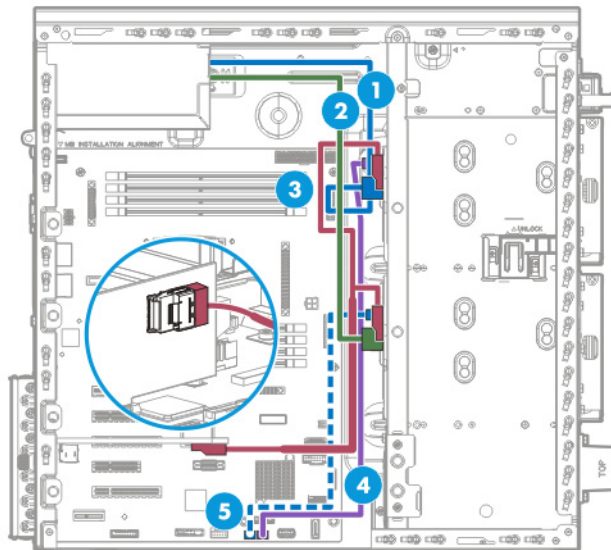

Item	Description
1	Box 2 drive power cable
2	Box 1 drive power cable
3	Mini-SAS Y-cable to the controller

Item	Description
4	Box 2 hard drive power good cable
5	Box 1 hard drive power good cable

- Box 1 and box 2 drive backplane connected to a P840 controller

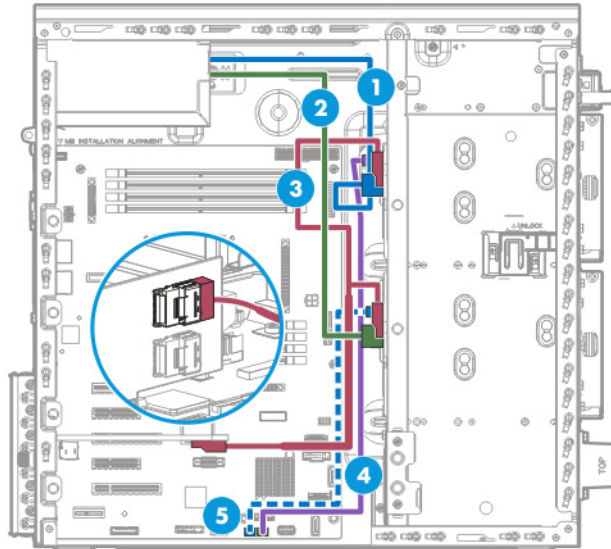

Item	Description
1	Box 2 drive power cable
2	Box 1 drive power cable
3	Mini-SAS Y-cable to port 1 of the controller
4	Box 2 hard drive power good cable
5	Box 1 hard drive power good cable

8-bay SFF hot-plug drive cabling

- Box 1 drive backplane connected to the system board

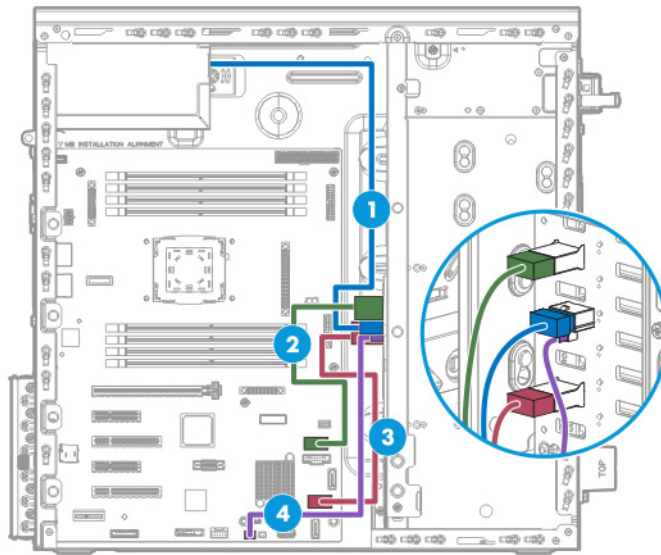

Item	Description
1	Drive power cable
2	Mini-SAS port 1 connection
3	Mini-SAS port 2 connection
4	Hard drive power good cable

- Box 1 drive backplane connected to an H240 adapter

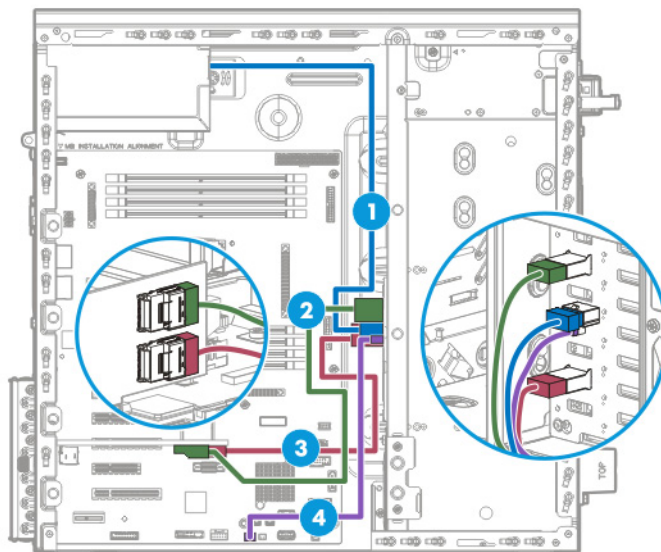

Item	Description
1	Drive power cable
2	Mini-SAS port 1 connection to port 1 controller
3	Mini-SAS port 2 connection to port 2 controller

Item	Description
4	Hard drive power good cable

- Box 2 drive backplane connected to an H240 adapter

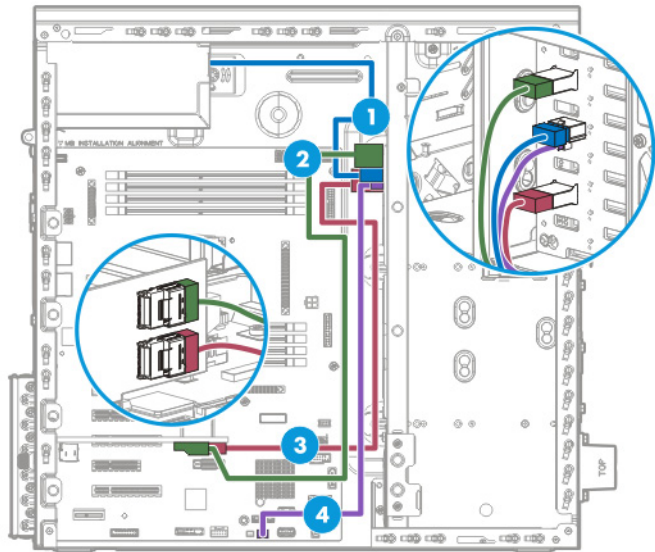

Item	Description
1	Drive power cable
2	Mini-SAS port 1 connection to port 1 controller
3	Mini-SAS port 2 connection to port 2 controller
4	Hard drive power good cable

- Box 1 drive backplane connected to a P440 controller

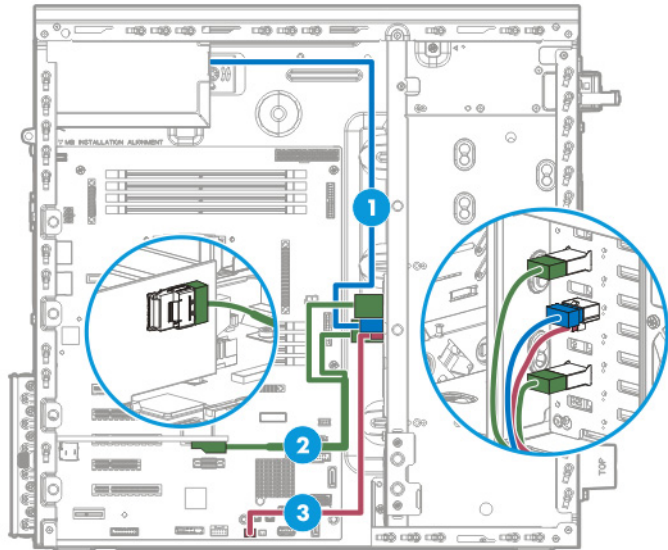

Item	Description
1	Drive power cable
2	Mini-SAS Y-cable to controller

Item	Description
3	Hard drive power good cable

- Box 2 drive backplane connected to a P440 controller

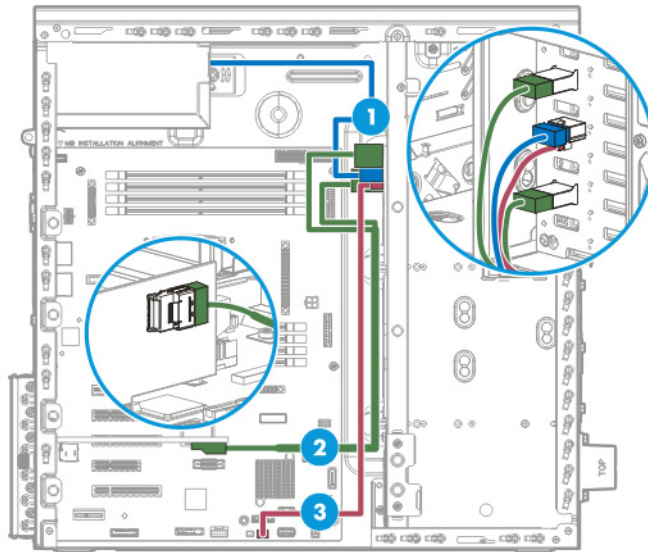

Item	Description
1	Drive power cable
2	Mini-SAS Y-cable to controller
3	Hard drive power good cable

- Box 1 drive backplane connected to a P840 controller

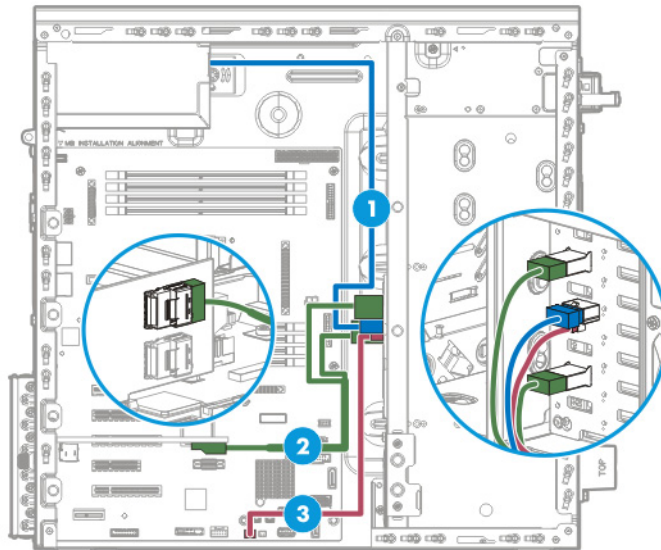

Item	Description
1	Drive power cable
2	Mini-SAS Y-cable connection to port 1 controller
3	Hard drive power good cable

- Box 2 drive backplane connected to a P840 controller

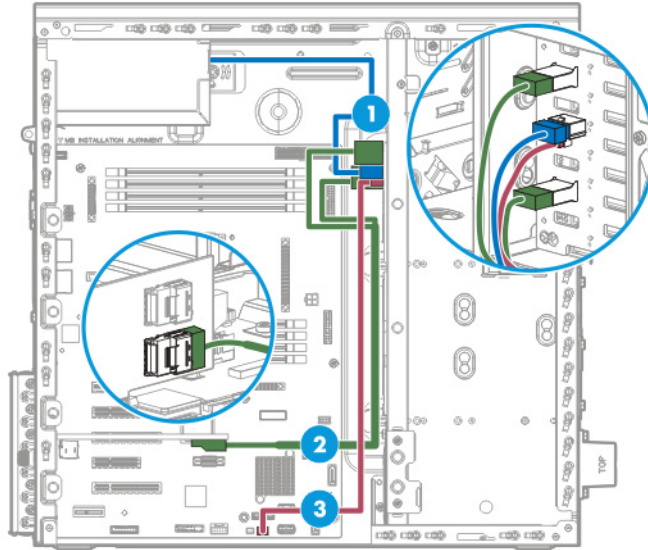

Item	Description
1	Drive power cable
2	Mini-SAS Y-cable connection to port 2 controller
3	Hard drive power good cable

FBWC module cabling

The FBWC solution is a separately purchased option. This server only supports FBWC module installation when an HP Smart Array P-Series controller is installed.

Depending on the controller option installed, the actual storage controller connectors might look different from what is shown in this section.

- FBWC module on a P440 controller

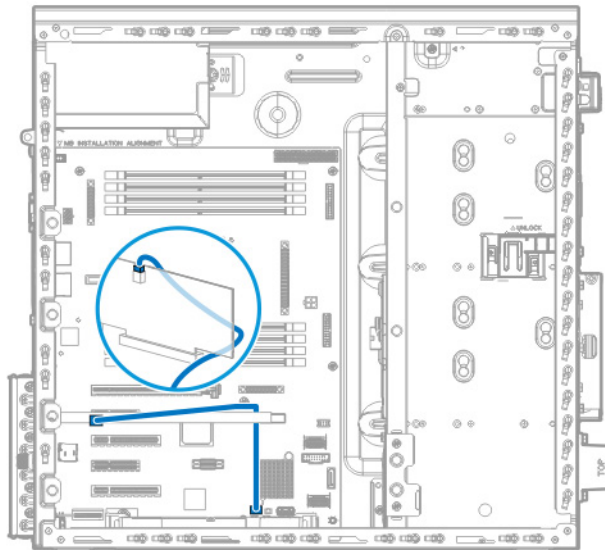

- FBWC module on a P840 controller

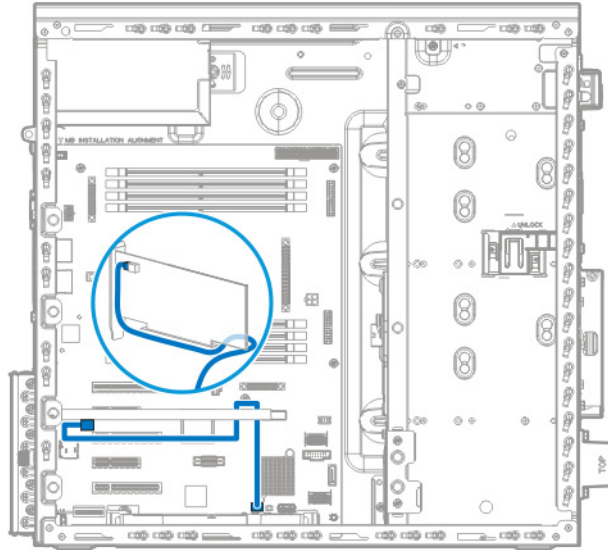

HP Smart Storage Battery cabling

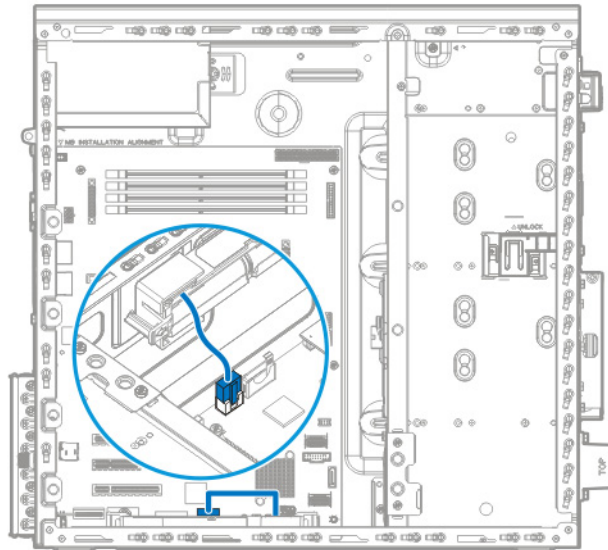

Optical drive cabling

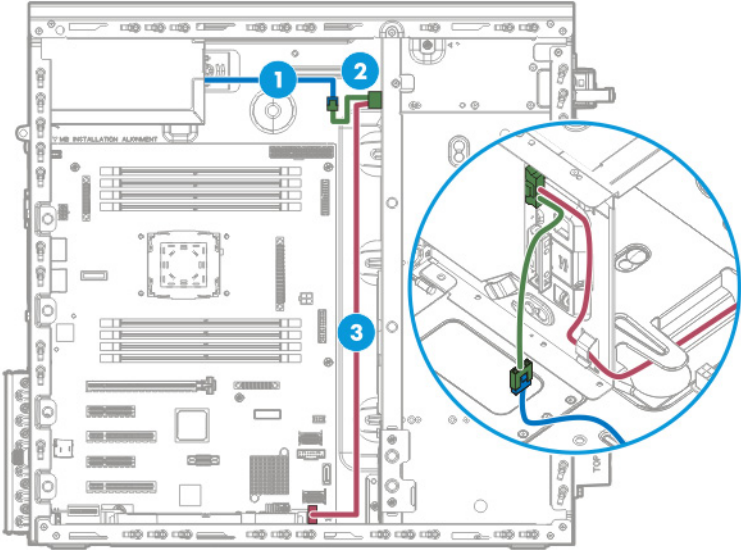

Item	Description
1	Power supply cable
2	Drive power cable
3	SATA cable

Fan cabling

- Default system fan (92 x 32 mm)

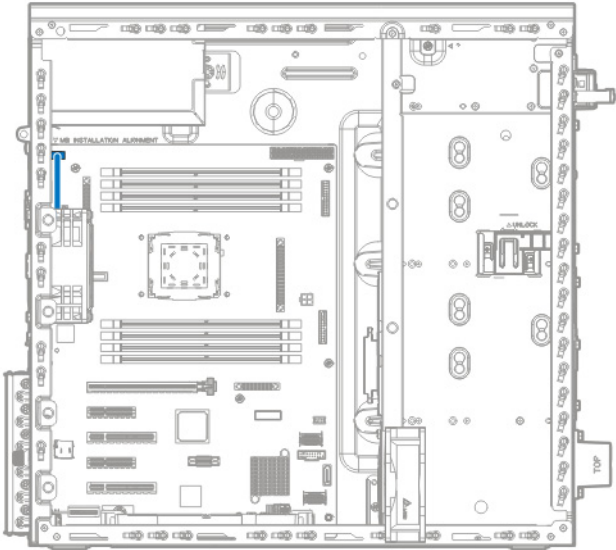

- Optional system upgrade fan (92 x 38 mm)

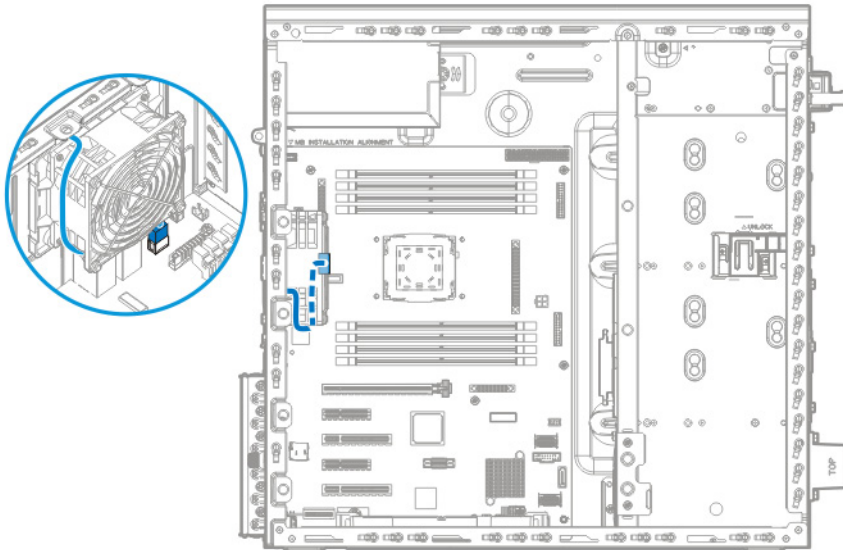

- PCI fan

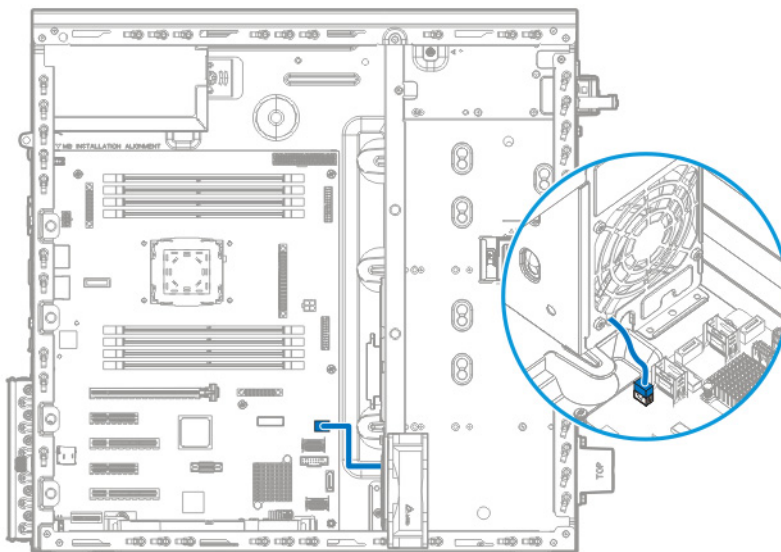

Power supply cabling

HP ATX 350-W power supply (non-hot-plug)

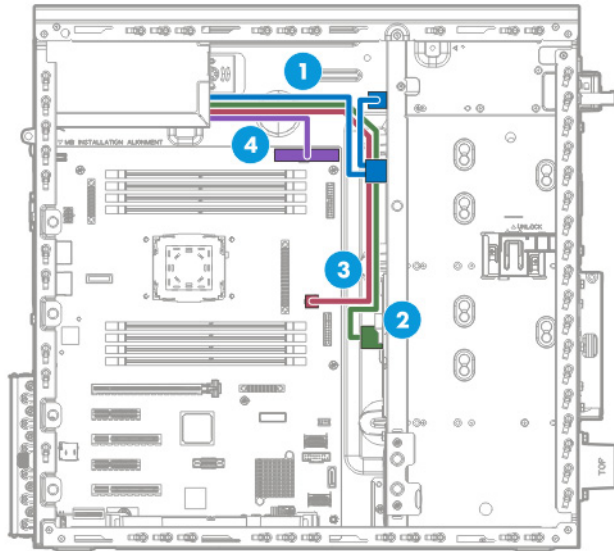

Item	Description
1	8-pin power supply cable to box 2 drive backplane and optical drive
2	8-pin power supply cable to box 1 drive backplane
3	4-pin power cable to system board
4	24-pin power supply cable

HP ATX 550-W power supply (non-hot-plug)

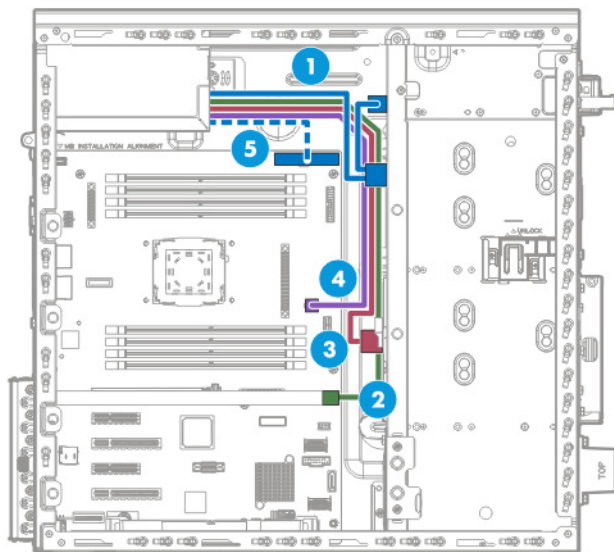

Item	Description
1	8-pin power supply cable to box 2 drive backplane and optical drive
2	6-pin power cable to GPU
3	8-pin power supply cable to box 1 drive backplane
4	4-pin power cable to system board
5	24-pin power cable to system board

HP 750-W redundant power supply

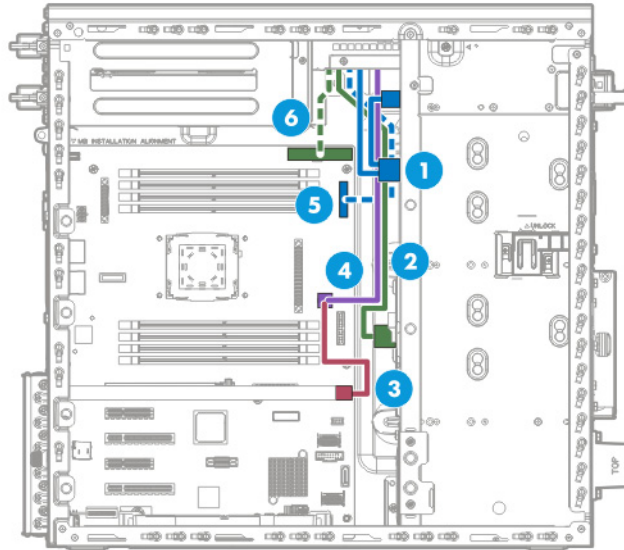

Item	Description
1	8-pin power supply cable to box 2 drive backplane and optical drive
2	8-pin power supply cable to box 1 drive backplane
3	6-pin power cable to GPU
4	4-pin power cable to system board
5	RPS cable to system board
6	24-pin power cable to system board

Front I/O cabling

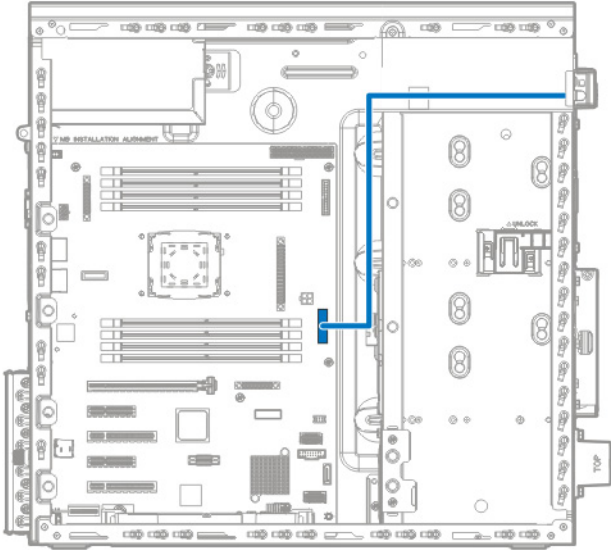

Front USB 3.0 cabling

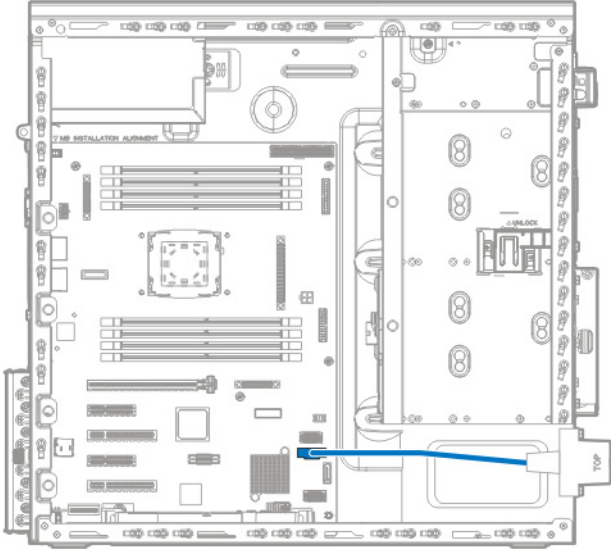

Specifications

Environmental specifications

Specification	Value
Temperature range*	—
Operating	10°C to 35°C (50°F to 95°F)
Nonoperating	-30°C to 60°C (-22°F to 140°F)
Relative humidity (noncondensing)	—
Operating	Minimum to be the higher (more moisture) of -12°C (10.4°F) dew point or 8% relative humidity Maximum to be 24°C (75.2°F) dew point or 90% relative humidity
Nonoperating	5% to 95% 38.7°C (101.7°F), maximum wet bulb temperature

* All temperature ratings shown are for sea level. An altitude derating of 1.0°C per 304.8 m (1.8°F per 1000 ft) to 3048 m (10,000 ft) is applicable. No direct sunlight allowed. Maximum rate of change is 20°C per hour (36°F per hour). The upper limit and rate of change might be limited by the type and number of options installed.

For certain approved hardware configurations, the supported system inlet temperature range is extended:

- 5°C to 10°C (41°F to 50°F) and 35°C to 40°C (95°F to 104°F) at sea level with an altitude derating of 1.0°C per every 175 m (1.8°F per every 574 ft) above 900 m (2953 ft) to a maximum of 3048 m (10,000 ft).
- 40°C to 45°C (104°F to 113°F) at sea level with an altitude derating of 1.0°C per every 125 m (1.8°F per every 410 ft) above 900 m (2953 ft) to a maximum of 3048 m (10,000 ft).

The approved hardware configurations for this system are listed on the HP website (<http://www.hp.com/servers/ASHRAE>).

Server specifications

Specification	Value
Dimensions (with feet/bezel)	—
Height	44.00 cm (17.32 in)
Depth	48.05 cm (18.92 in)
Width	19.50 cm (7.68 in)
Weight (approximate)	—
Maximum (all drives, power supplies, and processors installed)	24.9 kg (55.00 lbs)

Specification	Value
Minimum (one drive, power supply, and processor installed)	12.5 kg (27.56 lbs)

Power supply specifications

Depending on the installed options and/or the regional location where the server was purchased, the server is configured with one of the following power supplies:

- HP ATX 350-W Power Supply (non-hot-plug) (776442-B21)
- HP ATX 550-W Power Supply (non-hot-plug) (776444-B21)
- HP 750-W Common Slot Gold Hot Plug Power Supply (512327-B21)

This is supported when the two-bay HP RPS Enablement option (PN 784582-B21) is installed.

These are Entry Level Power Supply products for HP ProLiant servers. For more information about the power supply features, specifications, and compatibility, see the HP website (<http://www.hp.com/go/proliant/powersupply>).



CAUTION: Check the system and power supply input ratings before powering up the server.

Hot-plug power supply calculations

For hot-plug power supply specifications and calculators to determine electrical and heat loading for the server, see the HP Power Advisor website (<http://www.hp.com/go/hppoweradvisor>).

Acronyms and abbreviations

AMP

Advanced Memory Protection

API

application program interface

ASHRAE

American Society of Heating, Refrigerating and Air-Conditioning Engineers

BP

backplane

CSR

Customer Self Repair

FAT

file allocation table

FBWC

flash-backed write cache

GPU

graphics processing unit

HBA

host bus adapter

HP SIM

HP Systems Insight Manager

iLO

Integrated Lights-Out

IML

Integrated Management Log

LFF

large form factor

LOM

Lights-Out Management

NMI

nonmaskable interrupt

NVRAM

nonvolatile memory

ODD

Optical Disk Drive

PCIe

Peripheral Component Interconnect Express

POST

Power-On Self Test

RBSU

ROM-Based Setup Utility

REST

representational state transfer

RPS

redundant power supply

SAS

serial attached SCSI

SATA

serial ATA

SD

Secure Digital

SFF

small form factor

SIM

Systems Insight Manager

SPP

HP Service Pack for ProLiant

TPM

Trusted Platform Module

UEFI

Unified Extensible Firmware Interface

UID

unit identification

USB

universal serial bus

Documentation feedback

HP is committed to providing documentation that meets your needs. To help us improve the documentation, send any errors, suggestions, or comments to Documentation Feedback (<mailto:docsfeedback@hp.com>). Include the document title and part number, version number, or the URL when submitting your feedback.

Index

A

- access panel 25
- access panel, remove 25
- Active Health System 71
- ACU (Array Configuration Utility) 75
- air baffle, removal 27, 28
- air scoop 41
- ambient temperature 102
- Automatic Server Recovery (ASR) 76

B

- battery pack, removing 42
- bezel, removing 26
- boot options 72, 73

C

- cabling 88, 99
- cabling, battery pack 96
- cabling, drive 88, 89, 92
- cabling, fan 97
- cabling, FBWC 95
- cabling, front I/O 101
- cabling, front USB 3.0 101
- cabling, internal power 99
- cabling, Mini-SAS cable option 89, 92
- cabling, not-hot-plug power supply 99
- cabling, optical drive 97
- cabling, redundant power supply 100
- cache module battery pack 42
- Care Pack 74
- clearing NVRAM 82
- CMOS 82
- components, front panel 77
- components, rear panel 79
- components, system board 81
- crash dump analysis 83
- customer self repair (CSR) 6

D

- dedicated iLO management module 59
- diagnosing problems 69

- diagnostic tools 70, 73, 74, 76
- dimensions and weight 102
- DIMM slot locations 83
- DIMMs, removing 43
- documentation feedback 107
- drive blank 30, 31
- drive cabling 88
- drive carrier 28
- drive LEDs 86
- drive numbering 84
- drives, determining status of 86

E

- electrostatic discharge 23
- embedded UEFI diagnostics 73
- environmental specifications 102
- error messages 69
- external USB functionality 75

F

- fan cabling 97
- fan connectors 81
- fan location 84
- FBWC cabling 88
- FBWC module 41
- front bezel 26
- front I/O cabling 101
- front panel buttons 77, 78
- front panel components 77
- front panel LED power fault codes 78
- front panel LEDs 78

G

- GPU supporting holder option 39
- GPU supporting holder, removal 39
- grounding methods 23
- grounding requirements 23

H

- health driver 76
- health LED 78
- heatsink 44

- hot-plug drive blank 30
- hot-plug drive, removing 31
- hot-plug power supply 67
- hot-plug power supply calculations 103
- HP Insight Diagnostics 74
- HP Insight Diagnostics survey functionality 74
- HP Insight Online 74
- HP Insight Remote Support software 74
- HP ProLiant Pre-boot Health Summary 71
- HP Smart Storage Battery 42, 96
- HP Smart Storage Battery cabling 96
- HP SmartDrive LED definitions 86
- HP SSA (HP Smart Storage Administrator) 75
- HP Systems Insight Manager (SIM) 72, 74
- HP technical support 6
- HP Trusted Platform Module option 68
- humidity 102

I

- illustrated parts catalog 16
- iLO connector 77
- Insight Diagnostics 74
- Integrated Lights-Out (iLO) 70, 72
- Integrated Management Log (IML) 72
- Intelligent Provisioning 72, 74
- internal USB connector 74, 81

L

- LED, health 78
- LED, system power 78
- LEDs, drive 86
- LEDs, front panel 78
- LEDs, NIC 78
- LEDs, power fault 78
- LEDs, power supply 80
- LEDs, rear panel 80
- LEDs, unit identification (UID) 78
- legacy USB support 74

M

- management tools 70
- mechanical components 16
- memory dump 83
- microSD card slot 81
- Mini-SAS cabling 88, 89, 92

N

- NIC activity LED 78

- NIC connectors 77
- NIC link LED 78
- NMI functionality 83
- NMI header 83
- non-hot-plug drive carrier 28
- non-hot-plug drives 29
- non-hot-plug power supply 61, 103

O

- operating system crash 76, 83
- operating systems supported 74
- optical drive 34, 77
- optical drive cabling 97

P

- PCI air baffle 27
- PCI fan 38
- POST error messages 69
- power cabling 99
- power calculator 103
- power fault 78
- Power On/Standby button 77, 78
- power supply 61
- power supply cabling 99
- power supply specifications 103
- power supply, hot-plug 62, 65, 67, 103
- power supply, non-hot-plug 61, 103
- powering down 25
- power-on password 82
- preparation procedures 25
- problem diagnosis 69, 70
- processor 46
- Product ID 73

Q

- QR code label 72
- QuickSpecs 70

R

- RAID configuration 75
- rear panel components 79
- rear panel LEDs 80
- redundant power supply 62, 67
- redundant power supply cabling 100
- re-entering the server serial number 73
- removal and replacement procedures 23
- required tools 23
- requirements, environmental 102

ROM legacy USB support 74
ROM-Based Setup Utility (RBSU) 72

S

safety considerations 23
serial number 73
server specifications 102
server warnings and cautions 24
specifications, environmental 102
specifications, power supply 103
specifications, server 102
SPP 74
static electricity 23
storage cabling, hot-plug 89, 92
storage cabling, non-hot-plug 88
symbols on equipment 23
system air baffle 28
system board 51
system board battery 96
system board components 81
system components 19
system configuration settings 82
system fan 36
system maintenance switch 82

T

T-10/T-15 Torx screwdriver 23
technical support 6
temperature requirements 102
tools 23
TPM connector 81
troubleshooting resources 69
Trusted Platform Module (TPM) 68

U

UEFI System Utilities 72
UID (unit identification) 77, 78, 80
UID button 78
UID LED 77
upgrade fan module 37
USB connector 77
USB support 74

W

warnings 24
weight 102