

Elite 2 NVR8004X

UP to 16CH Tower NVR with 4HDD Bays

User's Manual



Copyright © EverFocus Electronics Corp,
Release Date: October, 2014

Notice: This content is subject to be changed without notice.

EVERFOCUS ELECTRONICS CORPORATION

Elite 2 NVR8004X

User's Manual

© 2014 EverFocus Electronics Corp
www.everfocus.com

All rights reserved. No part of the contents of this manual may be reproduced or transmitted in any form or by any means without written permission of the EverFocus Electronics Corporation.

Release Date: October, 2014

QuickTime is a registered trademark of the Apple Computer, Inc.

Windows is a registered trademark of the Microsoft Corporation.

Linksys is a registered trademark of the Linksys Corporation.

D-Link is a registered trademark of the D-Link Corporation.

DynDNS is a registered trademark of the DynDNS.org Corporation.

Other product and company names mentioned herein may be the trademarks of their respective owners.

Warranty

Based on the RMA policy, EverFocus Electronics Corporation ("EverFocus") will repair or replace, at no charge to the purchaser, any merchandise found to be defective in material or workmanship.

The NVR hardware is covered with a 2-year limited hardware warranty.

The supplied adaptor is covered with an 1-year limited hardware warranty.

Safety Precautions

- Refer all work related to the installation of this product to qualified service personnel or system installers.
- Do not block the ventilation openings or slots on the cover.
- Do not drop metallic parts through slots. This could permanently damage the appliance. Turn the power off immediately and contact qualified service personnel for service.
- Do not attempt to disassemble the appliance. To prevent electric shock, do not remove screws or covers. There are no user-serviceable parts inside. Contact qualified service personnel for maintenance. Handle the appliance with care. Do not strike or shake, as this may damage the appliance.
- Do not expose the appliance to water or moisture, nor try to operate it in wet areas. Do take immediate action if the appliance becomes wet. Turn the power off and refer servicing to qualified service personnel. Moisture may damage the appliance and also may cause electric shock.
- Do not use strong or abrasive detergents when cleaning the appliance body. Use a dry cloth to clean the appliance when it is dirty. When the dirt is hard to remove, use a mild detergent and wipe gently.
- Do not overload outlets and extension cords as this may result in a risk of fire or electric shock.
- Do not operate the appliance beyond its specified temperature, humidity or power source ratings. Do not use the appliance in an extreme environment where high temperature or high humidity exists. Use the NVR at temperatures within 0°C~40°C / 32°F~104°F (Storage). The input power source is 19 VDC / 90W.

- **Read Instructions**
All the safety and operating instructions should be read before the unit is operated.
- **Retain Instructions**
The safety and operating instructions should be retained for future reference.
- **Heed Warnings**
All warnings on the unit and in the operating instructions should be adhered to.
- **Follow Instructions**
All operating and use instructions should be followed.
- **Cleaning**
Unplug the unit from the outlet before cleaning. Do not use liquid cleaners, abrasive or aerosol cleaners. Use a damp cloth for cleaning
- **Attachments**
Do not use attachments not recommended by the product manufacturer as they may cause hazards.
- **Water and Moisture**
Do not use this unit near water-for example, near a bath tub, wash bowl, kitchen sink, or laundry tub, in a wet basement, near a swimming pool, in an unprotected outdoor installation, or any area which is classified as a wet location.
- **Servicing**
Do not attempt to service this unit by yourself as opening or removing covers may expose you to dangerous voltage or other hazards. Refer all servicing to qualified service personnel.
- **Power Cord Protection**
Power supply cords should be routed so that they are not likely to be walked on or pinched by items placed upon or against them, paying particular attention to cords and plugs, convenience receptacles, and the point where they exit from the appliance.
- **Object and Liquid Entry**
Never push objects of any kind into this unit through openings as they may touch dangerous voltage points or short-out parts that could result in a fire or electric shock. Never spill liquid of any kind on the unit.



ATTENTION! This is a class A product which may cause radio interference in a domestic environment; in this case, the user may be urged to take adequate measures.



Federal Communication Commission Interference Statement

This equipment has been tested and found to comply with the limits for a Class B digital device, pursuant to Part 15 of the FCC Rules. These limits are designed to provide reasonable protection against harmful interference in a residential installation. This equipment generates, uses and can radiate radio frequency energy and, if not installed and used in accordance with the instructions, may cause harmful interference to radio communications. However, there is no guarantee that interference will not occur in a particular installation. If this equipment does cause harmful interference to radio or television reception, which can be determined by turning the equipment off and on, the user is encouraged to try to correct the interference by one of the following measures:

- Reorient or relocate the receiving antenna.
- Increase the separation between the equipment and receiver.
- Connect the equipment into an outlet on a circuit different from that to which the receiver is connected.
- Consult the dealer or an experienced radio/TV technician for help.

FCC Caution: Any changes or modifications not expressly approved by the party responsible for compliance could void the users' authority to operate this equipment.



This Product is RoHS compliant.



Your EverFocus product is designed and manufactured with high quality materials and components which can be recycled and reused. This symbol means that electrical and electronic equipment, at their end-of-life, should be disposed of separately from your household waste. Please, dispose of this equipment at your local community waste collection/recycling centre. In the European Union there are separate collection systems for used electrical and electronic product.

Please, help us to conserve the environment we live in!

The information in this manual was current upon publication. The manufacturer reserves the right to revise and improve his products. Therefore, all specifications are subject to change without prior notice. Manufacturer is not responsible for misprints or typographical errors. Please read this manual carefully before installing and using this unit. Be sure to keep it handy for later reference.

TABLE OF CONTENTS

1. Introduction	1
1.1 Overview	2
1.2 Features	2
1.3 Packing List.....	3
1.4 Optional Accessory	3
1.5 Front Panel.....	4
1.6 Rear Panel	5
2. Installation	6
2.1 Hard Disk Drive Installation	6
2.1.1 Hard Disk Compatibility List	8
2.2 Basic Connection.....	10
2.3 Turning On / Off the Power	10
2.4 Connecting the NVR to the Network	11
2.4.1 Router or LAN Connection	11
2.4.2 Direct High-Speed Connection.....	14
2.4.3 One-to-One Connection.....	15
2.5 Checking the Dynamic IP Address.....	19
3. General Operation	22
3.1 Login / Logout	22
3.2 Live View Window.....	23
3.2.1 eMap	25
3.2.2 Live View Tool Bar	26
3.2.3 Device List Setup	27
3.2.3.1 Group Settings	28
3.2.3.2 Editing Device Configurations	29
3.2.3.3 Device Type List	29
3.2.3.4 Adding Devices	30
3.2.3.5 Device Indicator.....	31
3.2.4 Layout Setting	32
3.2.5 Page Setting	33
3.3 Recording	34
3.3.1 Setting up the Recording Path	35
3.4 Quick Playback	36
3.5 Setting	37
3.5.1 Date / Time.....	38
3.5.2 License.....	38

3.5.3	User Management	39
3.5.4	Recording Data Report.....	40
3.5.5	Disk Information.....	41
3.5.6	Storage Device Management.....	41
3.5.7	Motion Detect.....	44
4.	Specifications.....	45

Chapter 1

1. Introduction

EverFocus Elite 2 NVR8004X is a professional standalone network video server designed for small and medium-sized businesses (SMB) and enterprises. Operating on a Linux-based system, the NVR offers quick PC-less configuration, network-based surveillance connection, megapixel recording as well as playback, up to 12 TB storage capacities and more. It also supports industry standard compression codec, such as H.264 and M-JPEG. The device is compatible with all EverFocus IP cameras.

Other cutting-edge functions available on EverFocus Elite 2 NVR8004X include multi-channel playback at multiple speed options and easy data search by event date and time. With the newly improved Event Management function, users are now supplied with a much larger range of supported event types and handling options in the database. Suspicious activities and behaviors can be detected and responded to on a much more accurate and timely manner. In addition, EverFocus has further strengthened users' account management for secure access control in vertical markets, such as residential communities, parking lot, retail stores, shopping malls, banks, hospitals, offices, factories and much more. Users may enable and perform the specified functions through the web-based GUI by the Web browser.

EverFocus Elite 2 NVR8004X NVR is the best choice for a complete network-based surveillance solution. It is versatile, flexible and well caters to the needs of the industry.

1.1 Overview

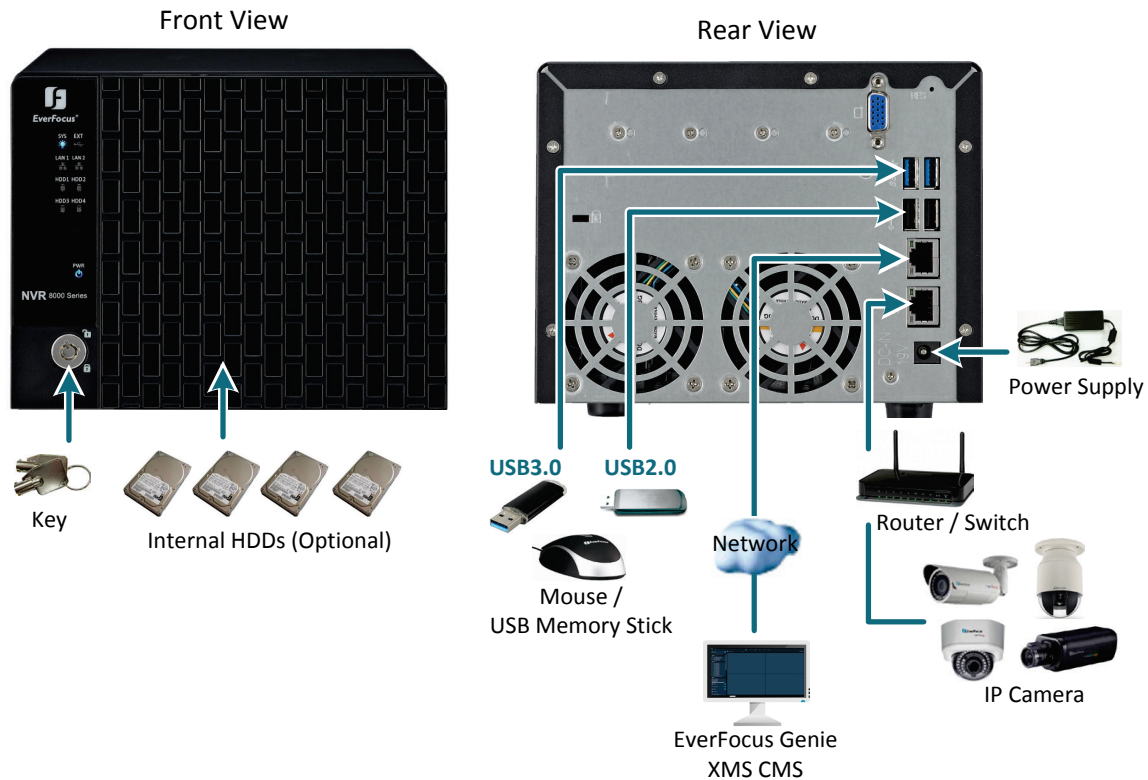









Figure 1-1

1.2 Features

- Elite 2 NVR8004X can support up to 16 channels
- Hard Drive Configurations in 2 / 4 / 8 / 12 TB
- 4 HDD Bays with removable hot swap trays
- Dual NIC for separation of streaming camera video from LAN / WAN monitoring network
- Built-in web server for single NVR live / playback viewing and configuration
- Raid: 0, 1, 5 and 10 configurable
- Free multi-site CMS displays live and playback video for up to 128 live and 16 playback cameras (dual monitors permit 2 x 64 live views; playback screen replaces one live view) from any combination of Elite 2 and Commander 2

1.3 Packing List

<ul style="list-style-type: none"> • NVR x 1 	<ul style="list-style-type: none"> • Quick Guide x 1
<ul style="list-style-type: none"> • CD x 1 *see note 3 	<ul style="list-style-type: none"> • Mouse x 1 
<ul style="list-style-type: none"> • Power Cord x 1 	<ul style="list-style-type: none"> • Adaptor x 1 
<ul style="list-style-type: none"> • Standard RJ45 cable x 1 	<ul style="list-style-type: none"> • Sticker x 1 *see note 4 
<ul style="list-style-type: none"> • Screw x 16 *see note 4 	<ul style="list-style-type: none"> • Key x 2 *see note 4 

Note:

1. Equipment configurations and supplied accessories vary by country. Please consult your local EverFocus office or agents for more information. Please also keep the shipping carton for possible future use.
2. Contact the shipper if any items appear to have been damaged in the shipping process.
3. The CD contains the IP Utility software, EF Player, JAVA software, Quick Installation Guide, and User's Manual.
4. The Sticker, Screws and Keys are contained in the HDD trays respectively.

1.4 Optional Accessory

- EKB200 (USB controller keyboard: connect to the PC to control the PTZ camera connected to the NVR).



1.5 Front Panel

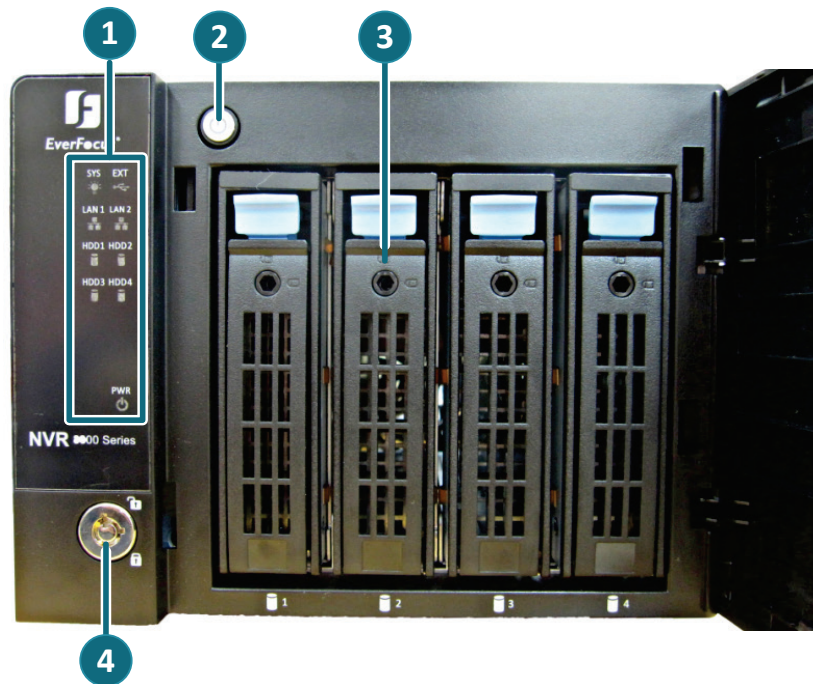

Figure 1-2

No.	Name	Description
1	Status LED	<p>SYS: Indicates the system is working.</p> <p>EXT: Indicates the NVR is connected to the external storage device or USB dongle.</p> <p>LAN1 / LAN2: Indicates the NVR is connected to the network.</p> <p>HDD1~4: Indicates the internal HDD is activating, but the LED indicators will light up only if you install the HDDs before turning on the NVR. If the NVR is already on and you hot-swap the HDDs, the HDD1~4 LED indicators will still remain on / off as the previous status, please see the example in the note below.</p> <p>PWR: Indicates the power is on.</p>
2	Power	Press to turn on / off the NVR.
3	HDD Tray	Pull the HDD tray out to install the HDD.
4	Lock	Use the supplied key to lock / unlock the NVR.

Note: For example, if the HDD1 is installed before turning on the NVR, the HDD1 LED indicators will emit light once the NVR is powered on. Then, if you hot-swap either one of HDD1~4, still only the HDD1 LED indicator remains light up. You can reboot the NVR manually and the HDD LED indication will be corrected.

1.6 Rear Panel

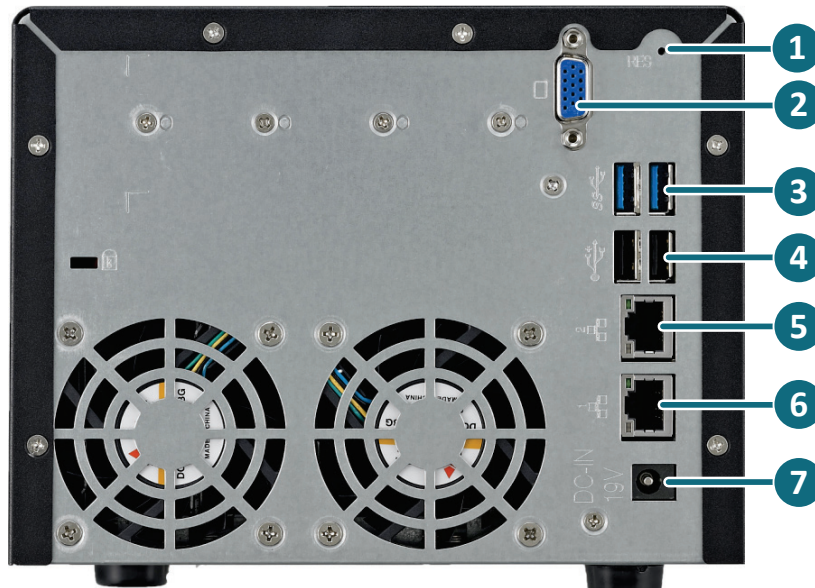

Figure 1-3

No.	Name	Description
1	Reset	Insert a tool into the reset hole to reset the NVR.
2	VGA Port	The function is currently reserved.
3	USB3.0 Port	The USB3.0 ports for connecting to a dongle, mouse or external storage device.
4	USB2.0 Port	The USB2.0 ports for connecting to a dongle, mouse or external storage device.
5	LAN2 (Static IP)	Connects to the Network. Please see <i>2.2 Basic Connection</i> for more details.
6	LAN1 (DHCP)	Connects to a router or switch for connecting IP cameras. Please see <i>2.2 Basic Connection</i> for more details.
7	Power Port	Connects to the 19 VDC power using the supplied Power Cord.

2. Installation

2.1 Hard Disk Drive Installation

1. Make sure the NVR is power-off, and open the cover on the front panel of the NVR.
2. Press the release latch, and the locking arm pops up.

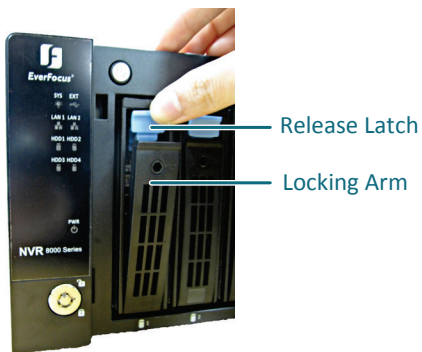

Figure 2-1

3. Gently pull the locking arm to take out the HDD tray.



Figure 2-2

4. Insert 2.5" or 3.5" HDD in the tray.



Figure 2-3

5. Secure the HDD with the supplied 4 screws to the tray.
 - a. 3.5" HDD:

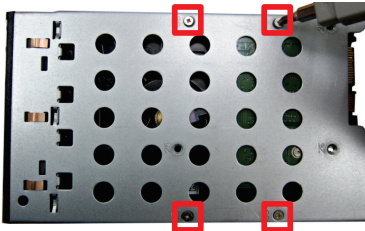

Figure 2-4

- b. 2.5" HDD:

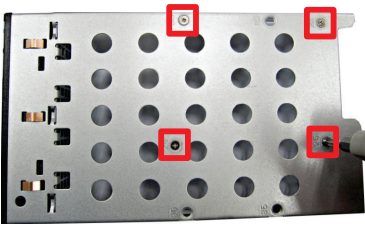

Figure 2-5

6. Push the HDD tray into the drive bay of the NVR with the locking arm unlatched.



Figure 2-6

7. Close the locking arm until you hear a click.



Figure 2-7

8. Close the cover of the NVR.

2.1.1 Hard Disk Compatibility List

Please use the hard disk models recommended in the list below to ensure your hard disks will be compatible.

Note: If using two or more hard disks, please choose the hard disks with the same capacity.

SATA Hard Disk	Model	Capacity
Seagate	SV35.5 SATA2 ST3500410SV	500GB
	SV35.5 SATA2 ST31000525SV	1TB
	SV35.5 SATA3 ST3500411SV	500GB
	SV35.5 SATA3 ST31000526SV	1TB
	SV35 SATA3 ST2000VX002	2TB
	Constellation ES.3 SATA3 ST4000NM0033	4TB
	Constellation CS SED SATA3 ST3000NC000	3TB
	CE-Video SATA3 / ST3500312CS	500GB
	CE-Video SATA3 / ST1000VM002	1TB
	CE-Video SATA3 / ST2000VM003	2TB
	CE-Video SATA3 / ST3000VM002	3TB
	CE-Video SATA3 / ST4000VM000	4TB
	ST4000VX000	4TB
	Western Digital	WD40PURX-64GVNYO
WD30PURX-64P6ZY0		3TB
WD20PURX-64P6ZY0		2TB
WD10PURX-64D85Y0		1TB
WD10EVDS SATA2		1TB
WD10EURS SATA2		1TB
WD10EURX SATA3		1TB
WD20EVDS SATA2		2TB
WD20EURS SATA2		2TB
WD30EURS SATA2		3TB
WD10EVVS SATA		1TB
WD20EFRX		2TB
WD30EFRX		3TB
WD4001FAEX		4TB
WD1600AVVS SATA		160GB
WD3200AVVS SATA		320GB
WD5000AVVS SATA		500GB
WD7500AVVS SATA		750GB
WD10EVVS SATA		1TB

Toshiba	MD03ACA200V	2TB
	MD03ACA300V	3TB
	MD03ACA400V	4TB
	DT01ABA050V	500GB
	DT01ABA100V	1TB
	DT01ABA200V	2TB
	DT01ABA300V	3TB
	MG03ACA100	1TB
	MG03ACA200	2TB
	MG03ACA300	3TB

2.2 Basic Connection

The instructions below describe the connection for the Elite 2 NVR8004X.

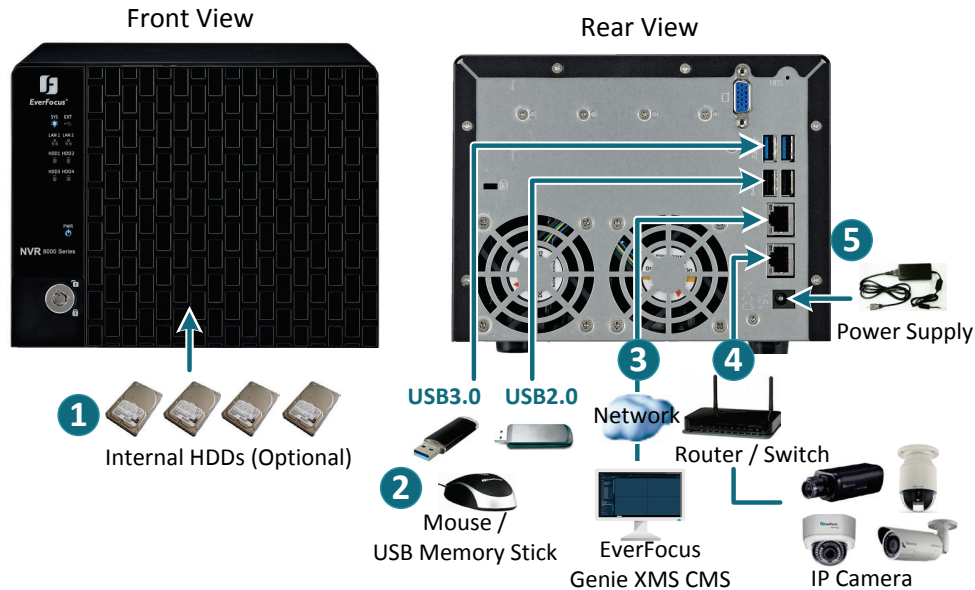

Figure 2-8

1. Install 1 to 4 HDDs (Please refer to *2.1 Hard Disk Installation*).
2. Optionally connect a Mouse and USB Memory Stick to the NVR.
3. To manage the NVR over network, it's recommended to connect the supplied standard RJ-45 cable from your network to LAN2 port.
4. To connect IP cameras, please use a router or switch to connect between NVR and IP cameras. It's recommended to connect the router or switch to the LAN1 of the NVR.
5. Using the supplied Power Cord, connect one end to the 19 VDC port on the NVR and the other end to the power outlet.

Note: Before powering on the NVR, please install the HDDs first. Please see *2.3 USB Dongle Connection* and *2.4 Turning On / Off the Power* for more details.

2.3 Turning On / Off the Power

Before powering on the NVR, please make sure the internal HDDs have been installed properly. When you have completed the basic cable connections, you are ready to turn on the NVR.

Once connect the supplied Power Cord to the power outlet, the NVR will be powered on. All of the LED indicators on the front panel will light up for a second, but the System and Power LED will remain light up. To turn off the power, simply unplug the Power Cord from the power outlet. You can also press the **Power** button inside the front panel to turn on and off the NVR without unplugging the Power Cord.

2.4 Connecting the NVR to the Network

There are three methods to connect the NVR to the network: **Router or LAN Connection**, **Direct High-Speed Connection** and **One-to-One Connection**.

2.4.1 Router or LAN Connection

This is the most common connection in which the NVR is connected to a router and allows multiple users on and off site to see the NVR on a LAN/WAN (Internet). The NVR must be assigned an IP address that is compatible with its LAN. By setting up port forwarding on the router, you can remotely access the cameras from outside of the LAN via the Internet.

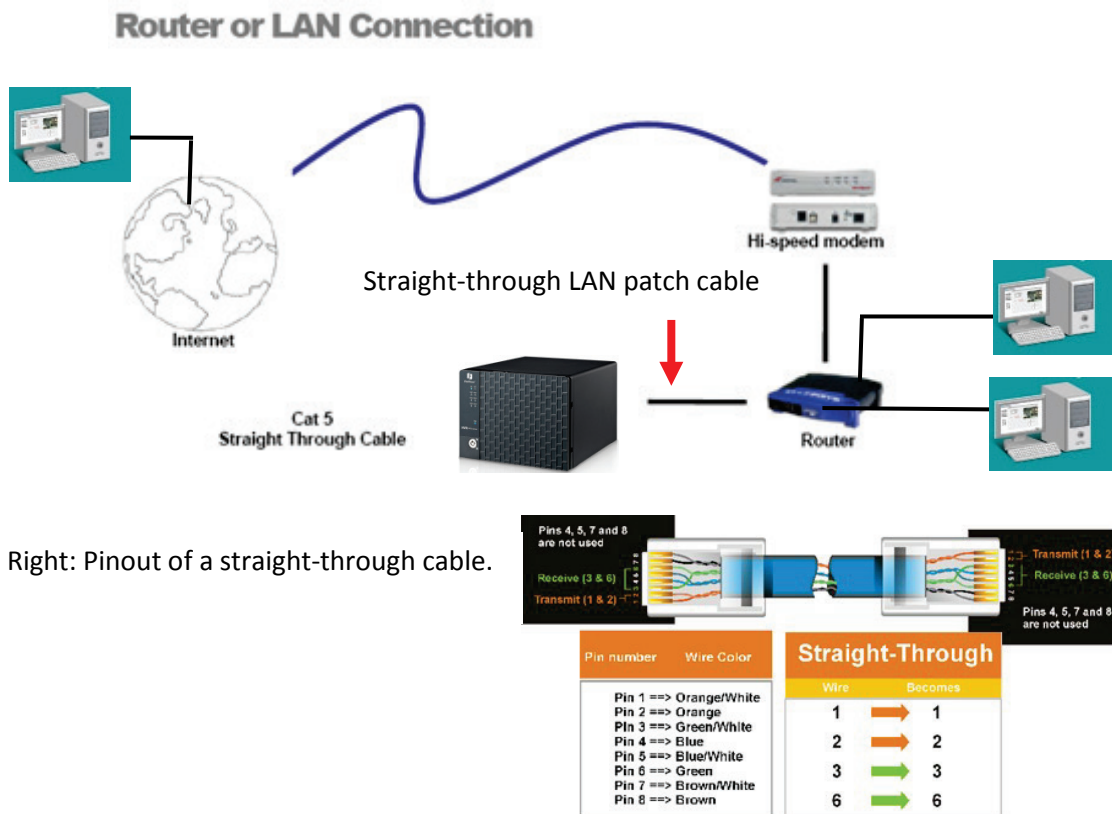

Figure 2-9

Connection Procedure:

- The First step is to purchase or make a straight through cable. We recommend purchasing one if you have never made a straight through cable. Please remember you can not use a cross-over network cable for this application.
- Once you have a straight through cable, plug one end into the LAN port on the back of the recorder and the other into the router.
- Log into the EverFocus NVR menu and go to the Network Setting Menu.
- To let the router automatically assign an address:
 - ◆ Set the Network Type to DHCP. Make sure to write down the IP address and the Gateway.
 - ◆ Exit from the Menu to save settings.

To manually assign an address:

- ◆ Go to a computer connected on the same network as the NVR.
- ◆ Click on the Start button and choose Run.
If using Windows Vista, choose Search instead.
- ◆ Type “command” and click on OK.
In Vista, you will need to double-click on the “Command Prompt” file to open it.
- ◆ In the DOS prompt, type “ipconfig” and press Enter.
- ◆ The network information will be displayed on a screen similar to the one below.
In Windows Vista, look for the information that says “IP v4”.

```

c:\ Command Prompt
Microsoft Windows XP [Version 5.1.2600]
(C) Copyright 1985-2001 Microsoft Corp.

C:\Documents and Settings\Steven>ipconfig

Windows IP Configuration

Ethernet adapter Local Area Connection:

    Connection-specific DNS Suffix . . :
    IP Address . . . . . : 192.168.0.80
    Subnet Mask . . . . . : 255.255.255.0
    Default Gateway . . . . . : 192.168.0.1

C:\Documents and Settings\Steven>
  
```

Figure 2-10

- ◆ Take the values for Subnet Mask and Default Gateway and input them into the NVR; these values should be exactly the same in both devices. However, you should change the last number of the IP address. For example, if the IP address of the computer is 192.168.2.101, the NVR's IP address should be 192.168.2.50.

- To access the NVR from a computer simply open Internet Explorer and in the address bar type:
http:// (IP address of the NVR)

Note: The NVR's IP address will only work at the location of the NVR. To connect from a different location over the Internet, see below.

To set the NVR for Internet Connection through router:

- The next step is to open ports within your router. Log into the router using a PC and open the following ports.
 - ◆ Ports to open: 80
 - ◆ If your Internet service provider blocks port 80, you can change it to a different port in the NVR's Network Menu Setup; open/forward that port instead.
 - ◆ If you are using a Linksys or D-Link router, see *Appendix B* for basic support on setting up ports. For any other router, you will need to contact the manufacturer for support.

- To access the NVR from a computer simply open Internet Explorer and in the address bar type:
http:// (the IP address given by your internet service provider)

Note: If you changed to a different port other than 80, you will need to include this at the end of the IP address:

http:// (the IP address given by your internet service provider):port number

- If you have a WAN Dynamic IP address and have opened the ports, go to *6.7.3 DDNS Setup* to configure the DDNS settings.

2.4.2 Direct High-Speed Connection

In a Direct High-Speed Connection, the NVR connects directly to a modem without the need for a router. You need to set the static or dynamic WAN IP address assigned by your ISP (Internet Service Provider) in the NVR's configuration web pages. To access the NVR, just type "http://xxx", where xxx is the IP address given by your ISP. If you have a dynamic IP address, this connection may require that you use DDNS for a reliable connection.

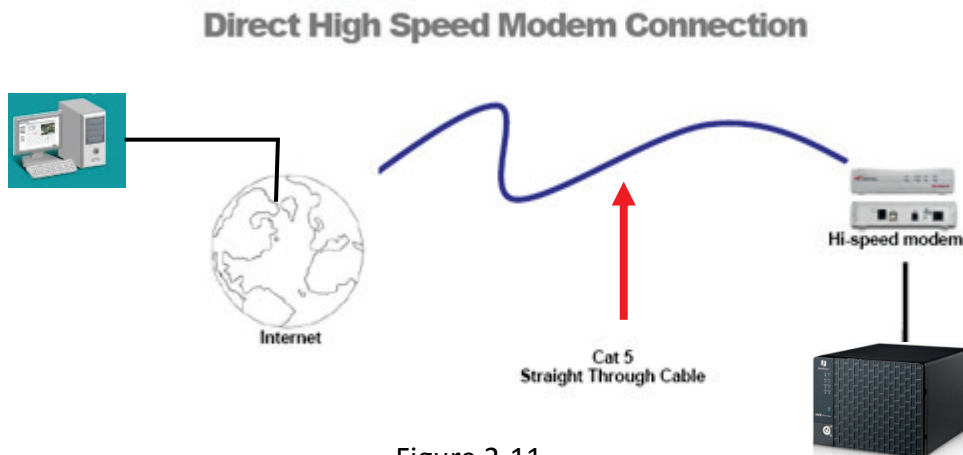

Figure 2-11

Connection Procedure:

- The first step is to purchase or make a straight through cable. We recommend purchasing one if you have never made a straight through cable. Please remember you can not use a cross-over network cable for this application
- Once you have a straight through cable plug one end into the LAN port on the back of the recorder and the other into the high speed modem.
- Log into the EverFocus NVR menu and go to the Network Setting Menu.
- Input the Static IP address, the Subnet Mask, and the Gateway that you obtained from the internet service provider.

Note: If you have a dynamic IP address, you can set the NVR to DHCP to automatically detect the network settings. Therefore, it can use a dynamic IP address.

- Exit from the NVR's Menu to save the settings.
- To access the NVR from a computer, open Internet Explorer and in the address bar type: http:// (IP address given by your internet service provider)

Note: When using this type of connection, only one device can be connected to the modem at a time. You will need to use a computer at a different location to test the connection s.

2.4.3 One-to-One Connection

You can connect directly without using a switch, router or modem. However, only the PC connected to the NVR will be able to view the NVR. You will also have to manually assign a compatible IP address to both the computer and the NVR. Unless the PC has another network connection, the NVR will be the only network device visible to the PC. See the diagram below:

Simple One to One Connection

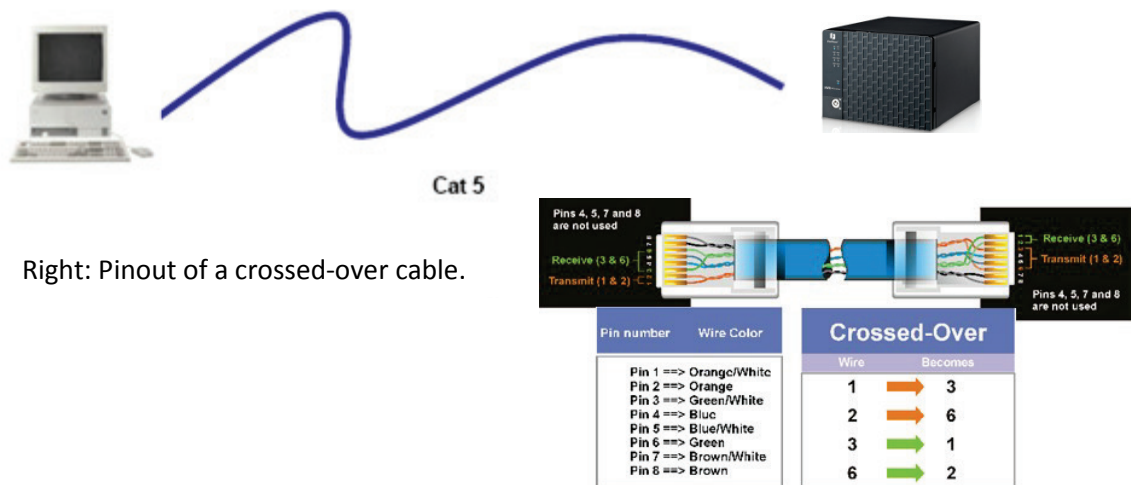

Figure 2-12

Connection Procedure:

- The First step is to purchase or make a cross-over cable. We recommend purchasing one if you have never made a cross-over cable. Please remember you can not use a straight through network cable for this application.
- Once you have a cross-over cable, plug one end into the LAN port on the back of the NVR and the other into the network card on the back of the computer.
- Log into the EverFocus NVR menu and go to the Network Setting Menu.
- You must use the Static IP option for this type of connection.
- Assign an IP of 192.168.001.003, a Subnet Mask of 255.255.255.000, and a Gateway of 192.168.001.001. You can ignore DNS Server.
- The next step is to set the computer's network settings to match those of the NVR. You will need Administrator privileges on your Windows machine to do this.
- To assign a fixed IP address in Windows 2000/XP, follow the instructions below:

- ◆ Go to **Start**. Double-click on **Control Panel**.

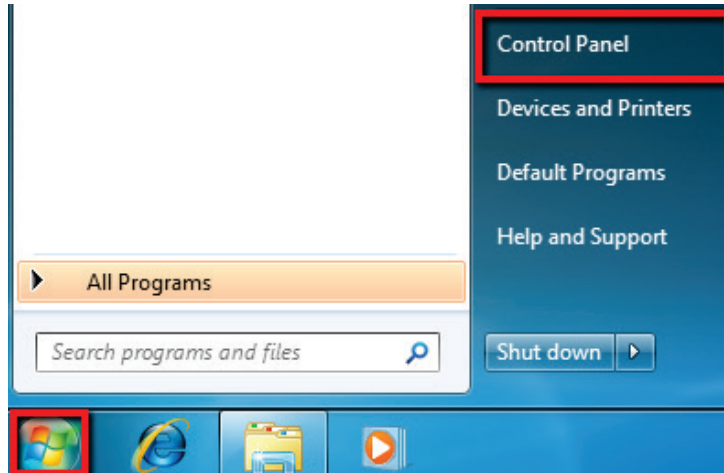

Figure 2-13

- ◆ Click **Network and Sharing Center**.

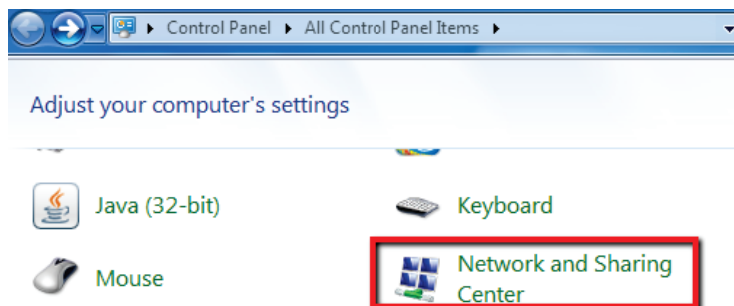

Figure 2-14

- ◆ Click **Local Area Connection**.

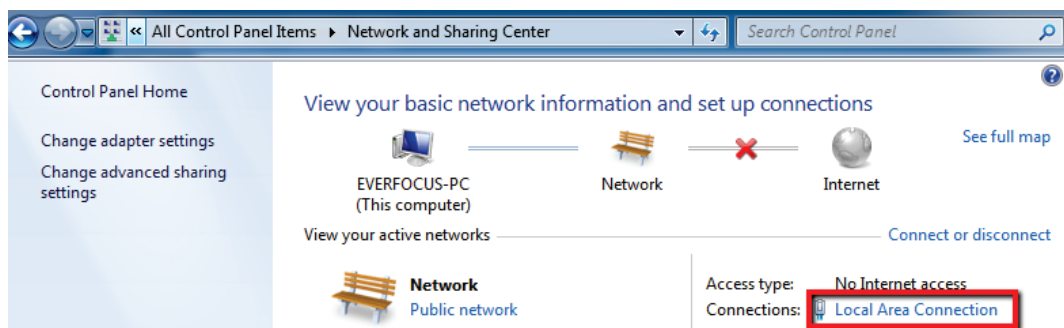

Figure 2-15

- ◆ Click **Properties**.

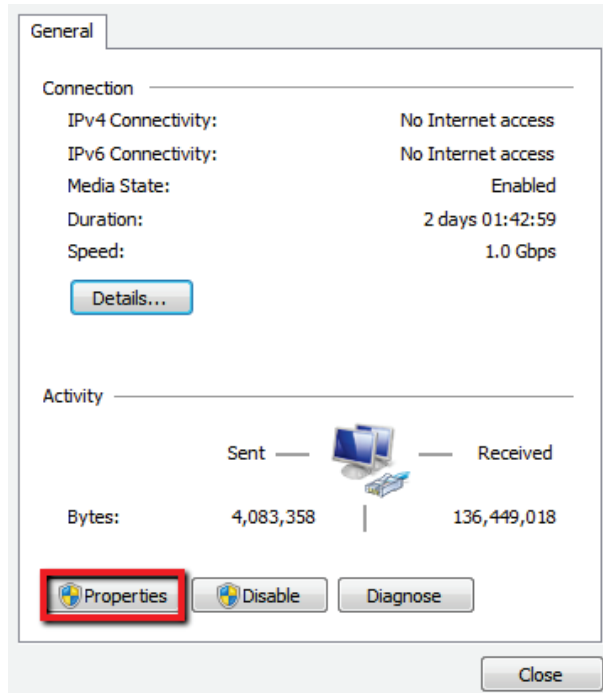

Figure 2-16

- ◆ Click on **Internet Protocol Version 4 (TCP/IPv4)** and then click **Properties**.

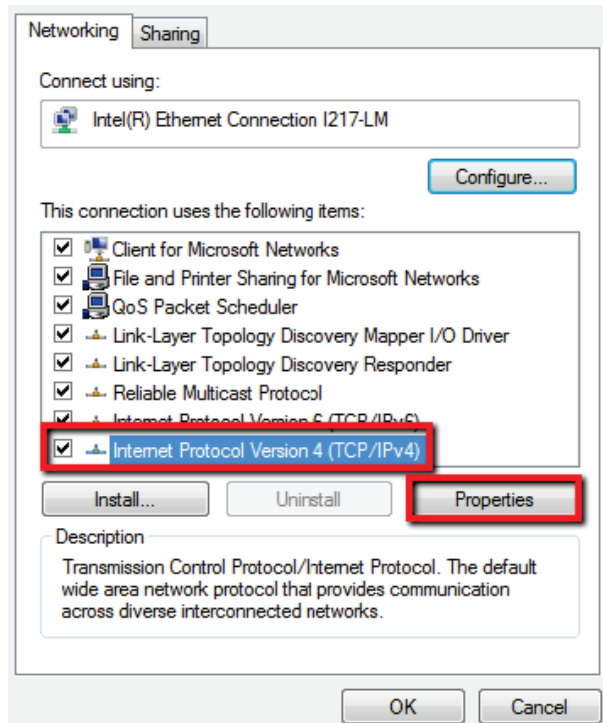

Figure 2-17

- ◆ Select **Use the following IP address**. Assign an IP address of 192.168.1.2, a Subnet Mask of 255.255.255.0, and a Default Gateway of 192.168.1.1 and then click **OK**.

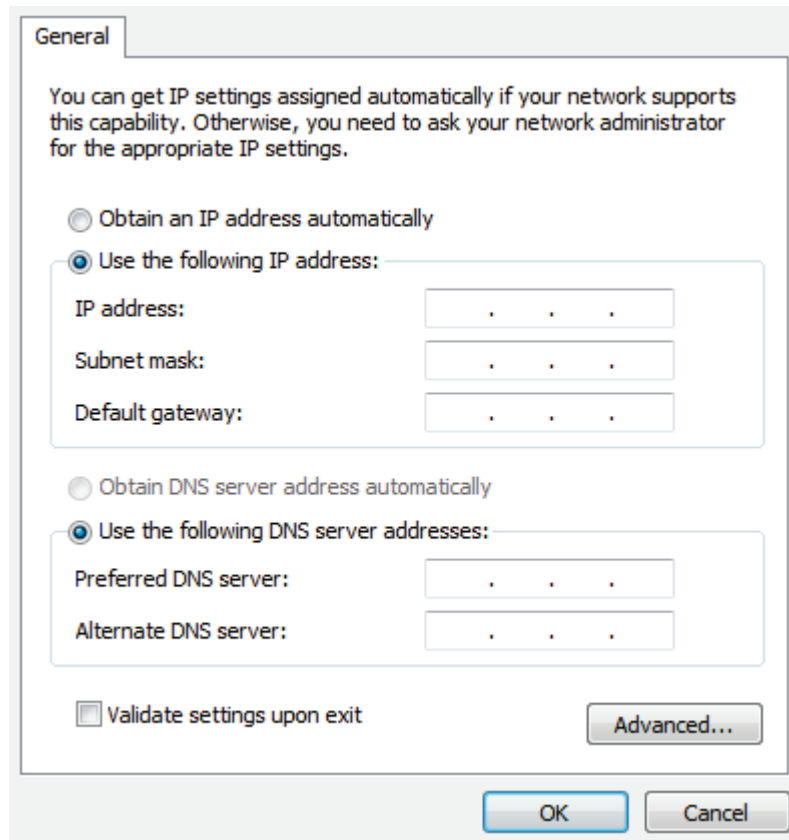

Figure 2-18

- ◆ Restart both of the computer and the NVR.
- ◆ To access the NVR from the computer, simply open Internet Explorer and in the address bar type: http://192.168.1.3

2.5 Checking the Dynamic IP Address

You can look up the IP address and access the Web interface of the NVR using the **IP Utility (IPU)** program, which is contained in the CD. It can also be downloaded from EverFocus' Website: http://www.everfocus.com/HQ/Support/DownloadCenter_p1.aspx. Please connect the NVR in the same LAN of your computer.

1. Install and then start the IPU program . The following dialog box appears.

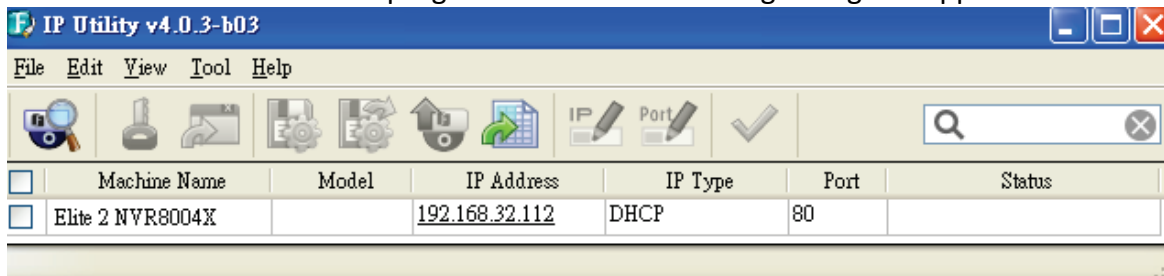

Figure 2-19

2. IPU will automatically search the IP devices connected in the LAN. The default network values of the IP devices will be displayed. By default, the network protocol of the IP device is **DHCP**.
3. To optionally configure the Machine Name, IP Address, IP Type or Port Number using the IPU:

- a. Log in the NVR by checking the desired model and then click the **Log in**  icon. The Log in dialog box appears.



Figure 2-20

- b. Type the Username and Password. Click the **OK** button, the status of the selected camera will display **Login**.

Machine Name	Model	IP Address	IP Type	Port	Status
<input checked="" type="checkbox"/> Elite 2 NVR8004X		192.168.32.112	DHCP	80	Login

Figure 2-21

Note:

1. The default user ID is **admin** and the default password is **11111111**.
2. If you select more than one NVRs that have the same user ID / password, you will be able to log in several NVRs at once.

- c. Right click the column to configure the setting. Click **Apply Changes**  button to apply and save the settings.

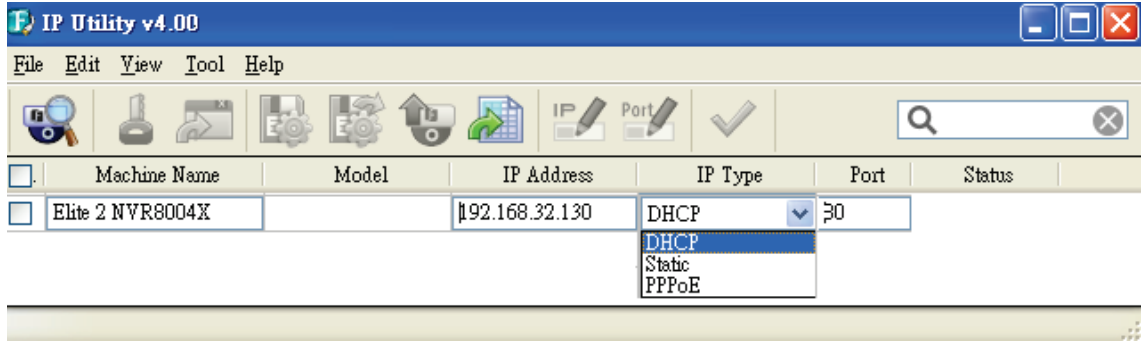

Figure 2-22

Note: Most networks uses DHCP to assign IP address, if you are unsure of your network settings, please consult your network administrators for configuration details.

- 4. To access to the Live View window, open a Google Chrome Web browser, type the IP address of the NVR in the address field and press the **Enter** key on the keyboard, the Welcome window pops up. Follow the instruction steps to update the latest Plugin version.

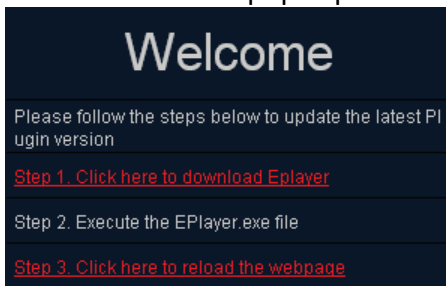

Figure 2-23

Note: The Welcome window will only be prompted for the first time login in order to update the system to the latest plugin version.

- 5. After reloading the webpage, the login window pops up. Type the user ID and password to log in. By default, the user ID is **admin** and the password is **11111111**.

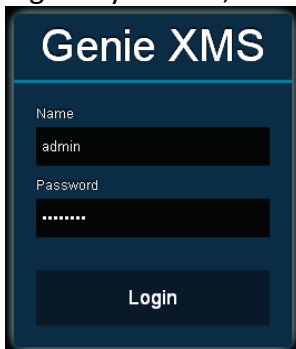

Figure 2-24

6. Click the **Login** button, the Live View window (see 3.2 *Live View Window*) appears.

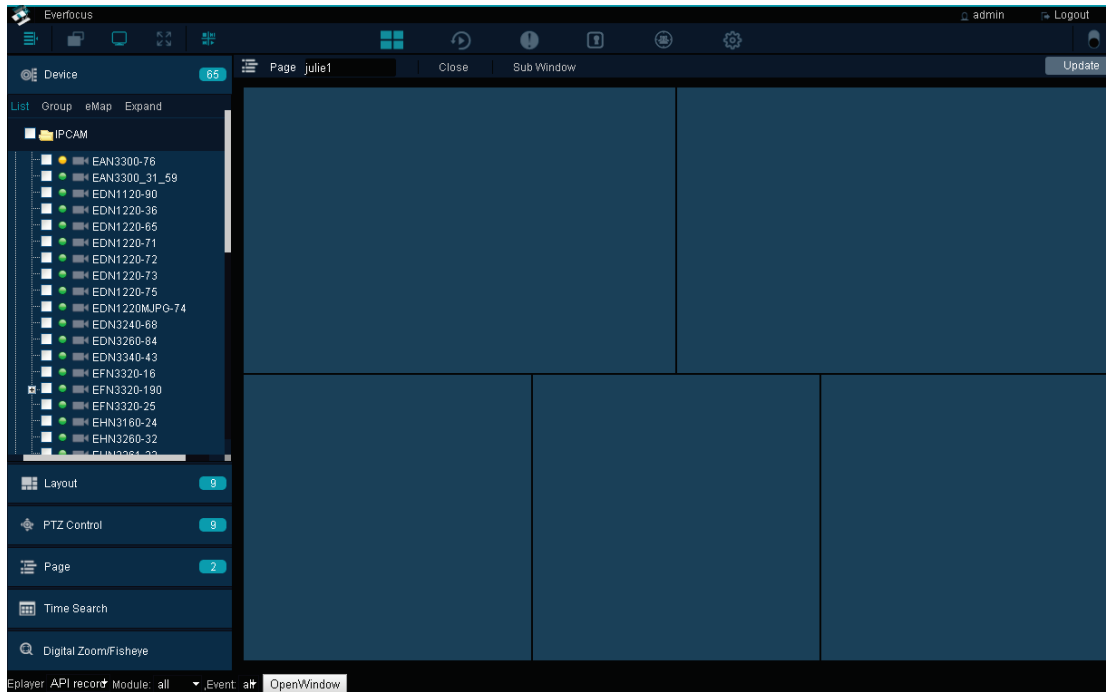

Figure 2-25

3. General Operation

You can view the live videos or operate the Live View Window through the Web browser.

3.1 Login / Logout

1. To log in the system, open a Google Chrome Web browser, type the IP address of the NVR in the address field and press the Enter key on the keyboard, the Welcome window pops up. Follow the instruction steps to update the latest Plugin version. After reloading the webpage, the login window pops up. Type the user ID and password to log in. By default, the user ID is admin and the password is 11111111.

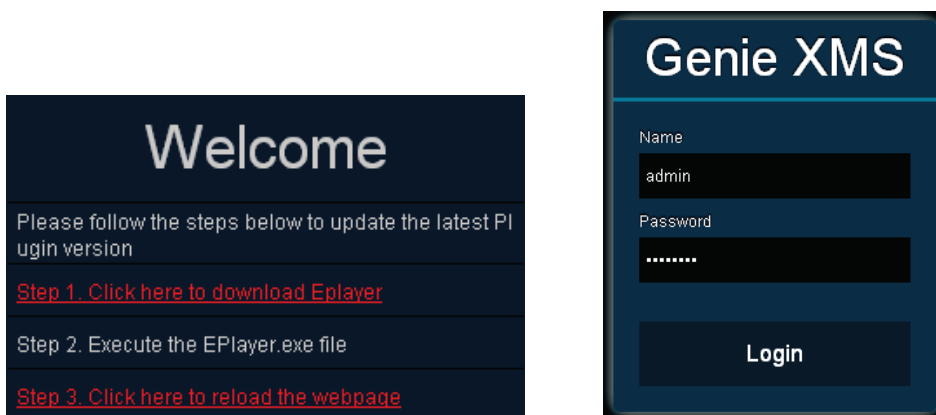

Figure 3-1

Note: The Welcome window will only be prompted for the first time login in order to update the system to the latest plugin version.

2. To log out the system, click the **Logout** button on the upper-right corner of the Live View Window. The system will return to the login window.



Figure 3-2

3.2 Live View Window

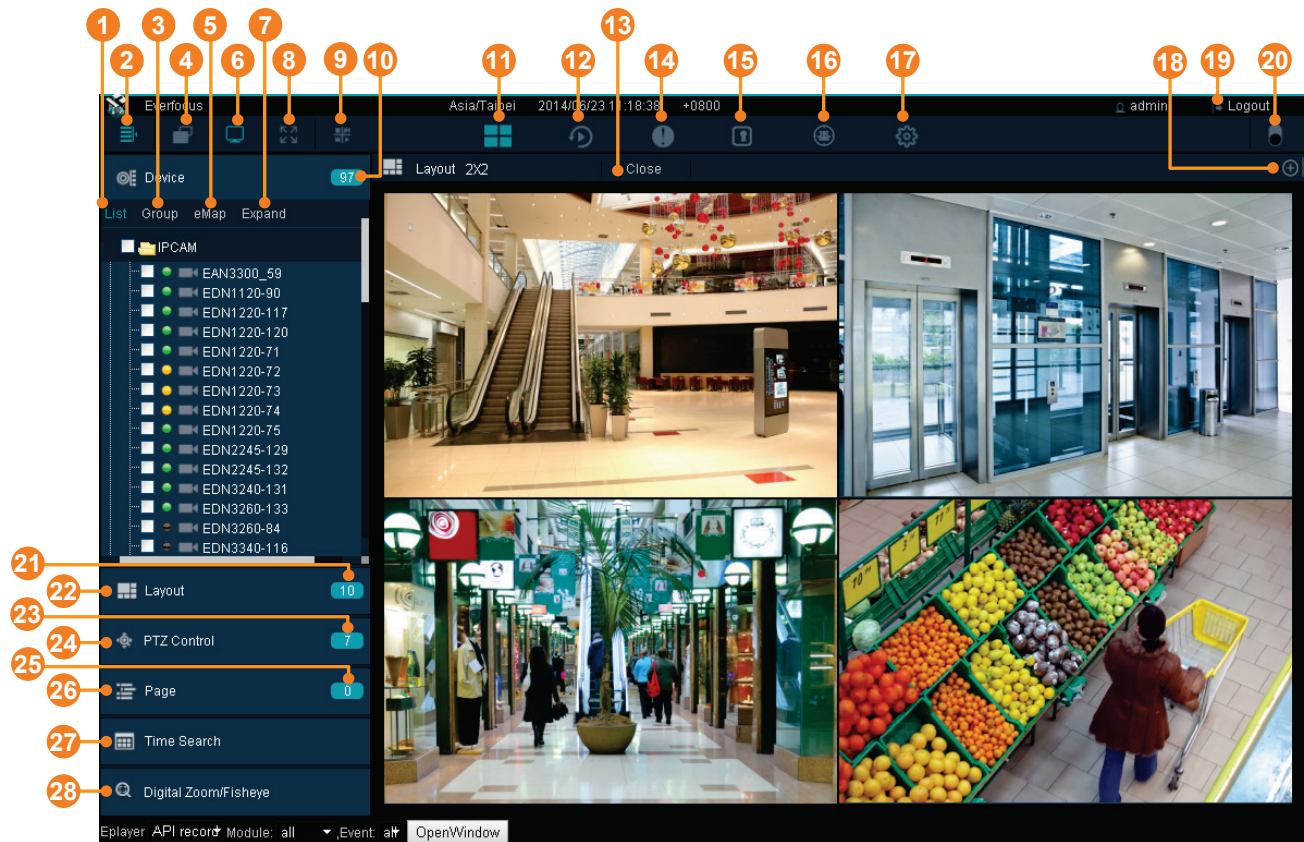

Figure 3-3

No.	Name	Description
1	List	Click to display the Device List
2	Menu Tree	Click to show / hide the Menu Tree of the Device List.
3	Group	Click to configure the Group settings (see 3.2.3.1 <i>Group Settings</i>).
4	Ratio	Click to switch live video ratio between original (source video) and extended (to the layout screen).
5	eMap	Click to display the eMap (see 3.2.1 <i>eMap</i>).
6	OSD Display Mode	Click to show / hide the information of device name and time.
7	Expand / Collapse	Click to expand or collapse the Device List.
8	Full Screen	Click to display the Live View layout in full screen.
9	Option	Click to show / hide the Live View Tool Bar at the bottom of each cell. See 3.2.2 <i>Live View Tool Bar</i> for more details.
10	Device Detail	Click to enter the Device List setup page (see 3.2.3 <i>Device List</i>

		<i>Setup</i>).
11	Live View	Click to display the Live View layout.
12	Playback	Click to enter the playback page for multi-channel playback.
13	Close Stream	Click to disconnect the live streams.
14	Event List	Click to enter the Event List setup page.
15	Access List	This function is optional. Click to enter the Access Control setup page.
16	IVS	This function is optional. Click to enter the Intelligent Video Surveillance (IVS) setup page.
17	Setting	Click to enter the Settings page (see <i>3.5 Setting</i>).
18	Add	Click to save the current live layout as a Page in the Page List (see <i>3.2.5 Page Setting</i>).
19	Logout	Click to log out the system.
20	Theme Switch	Click to switch the theme between the dark and light.
21	Layout Detail	Click to enter the Layout Design page. You can further create or modify the personal layout design (see <i>3.2.4 Layout Setting</i>).
22	Layout	Click to enter the layout page for layout selection (see <i>3.2.4 Layout Setting</i>).
23	PTZ Detail	Click to enter the PTZ setup page.
24	PTZ Control	Click to display the PTZ Control panel.
25	Page Detail	Click to enter the Page setup page (see <i>3.2.5 Page Setting</i>).
26	Page	Click to display the Page List (see <i>3.2.5 Page Setting</i>).
27	Time Search	Click to display the Time Search calendar for playback.
28	Digital Zoom / Fisheye	Click to enter the Digital Zoom / Fisheye operation page.

3.2.1 eMap

On the Live View Window, click the **eMap** button, the eMap page appears.

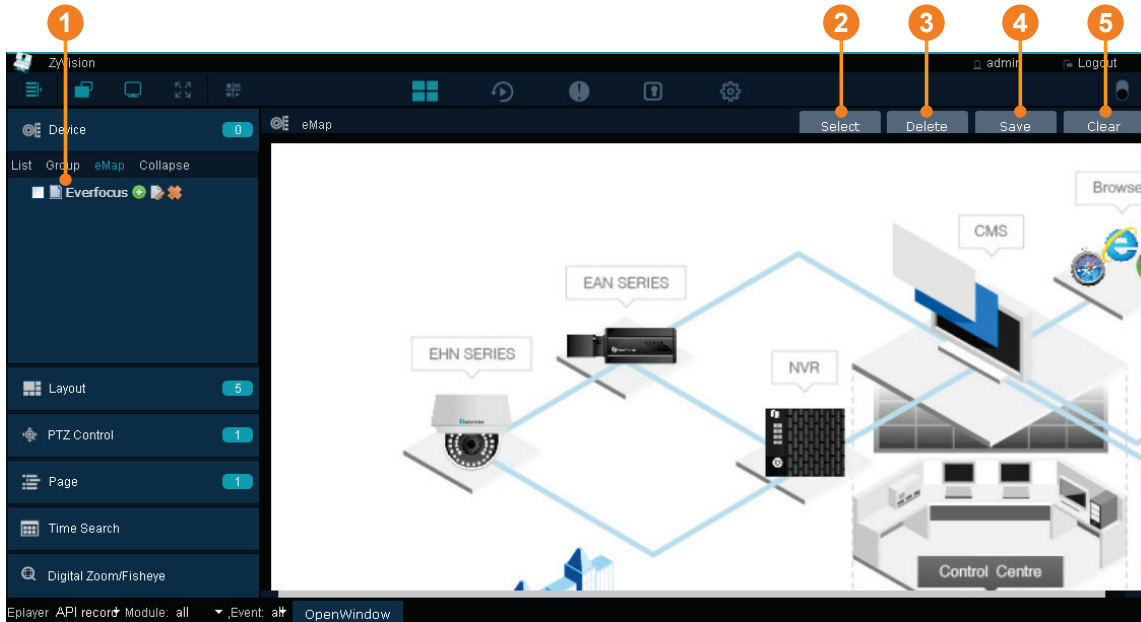

Figure 3-4

No.	Name	Description
1	List	Click to display the eMap list.
2	Select	Click to select an eMap picture (PNG, JPG, JPEG, GIF, TIFF).
3	Delete	Click to delete an eMap.
4	Save	Click to save the settings.
5	Clear	Click to clear the eMap settings.

3.2.2 Live View Tool Bar

You can use the Live View Tool Bar to control the main / sub streams, local recording, audio, snapshot and playback of the IP camera. On the Live View Window, click the **Option** button, the Live View Tool Bar appears on the top of the live view cell.

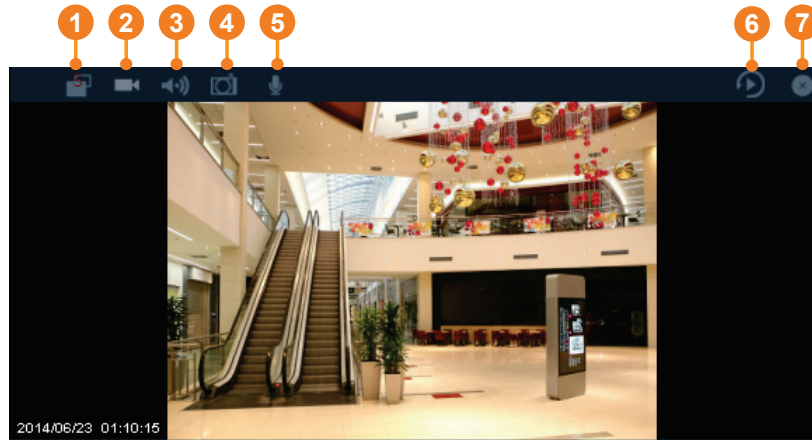

Figure 3-5

No.	Name	Description
1	Stream Type	Click to switch between main and sub stream.
2	Record	Click to start / stop local recording. You have to set up the recording path for the recordings in advance (see 3.3.1 <i>Setting up the Recording Path</i>).
3	Audio (Speaker)	Click to transfer the sound from the device to the client side (remote client PC) if the speakers have been connected to the device. Note that a (built-in) amplifier and external power supply are required for the speakers.
4	Snapshot	Click to take a snapshot. You have to set up the recording path for the snapshots in advance (see 3.3.1 <i>Setting up the Recording Path</i>).
5	Microphone	Click to transfer the sound from the client side (remote client PC) to the device if the microphones have been connected to the client side. Note that a (built-in) amplifier and external power supply are required for the microphones.
6	Quick Playback	Click to display the Quick Playback Bar for playing back (see 3.4 <i>Quick Playback</i>).
7	Close	Click to disconnect the stream.

3.2.3 Device List Setup

You can configure and manage the device list using this page. On the Live View Window, click the **Device Detail** button, the Device List Setup page appears on the right window.

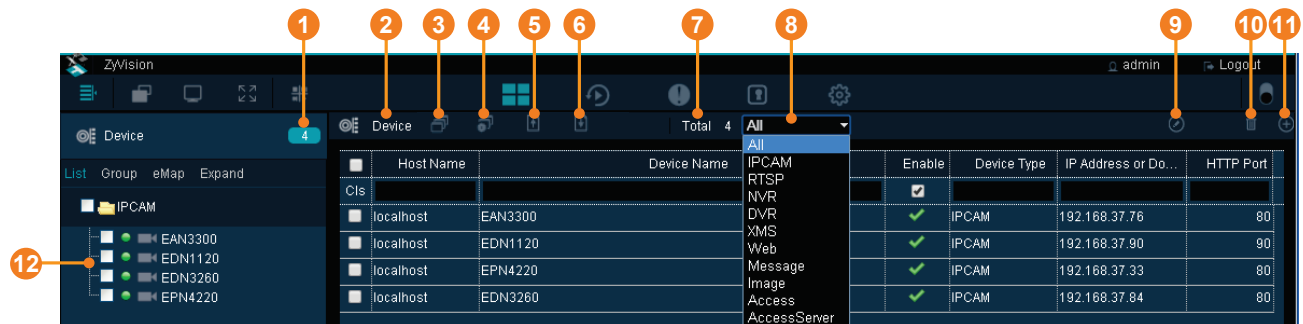

Figure 3-6

No.	Name	Description
1	Device Detail	Click to enter the Device List setup page.
2	Device	Click to display the Device List.
3	Group / List	Click to switch between Group view and List view for the Device List. You can also setup the Group settings (see 3.2.3.1 <i>Group Settings</i>).
4	Edit / View	Click to switch between Edit and View mode for the Device List. For editing the added devices, see 3.2.3.2 <i>Editing Device Configurations</i> .
5	Export	Click to export the Device List file (.csv).
6	Load Template	Click to download the Device List Template (.csv).
7	Total	Display the current number of the connected devices.
8	Device Type List	Click the drop down list and select the desired device type (see 3.2.3.3 <i>Device Type List</i>).
9	Import	Click to import the Device List file (.csv).
10	Delete	Select the desired devices and click the Delete button to remove the devices from the Device List.
11	Add	Click to enter the Maintain page for adding devices. For more details on adding devices, see 3.2.3.4 <i>Adding Devices</i> .
12	Device Indicator	The Device Indicator indicates the status of the devices (see 3.2.3.5 <i>Device Indicator</i>).

3.2.3.1 Group Settings

You can configure the group settings on this page.

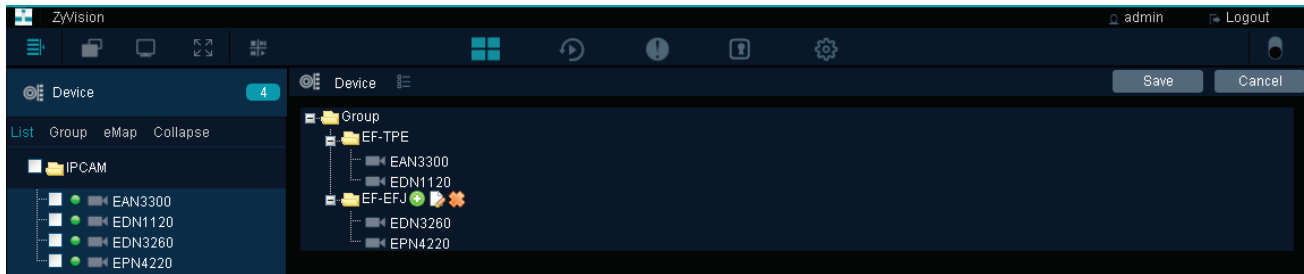
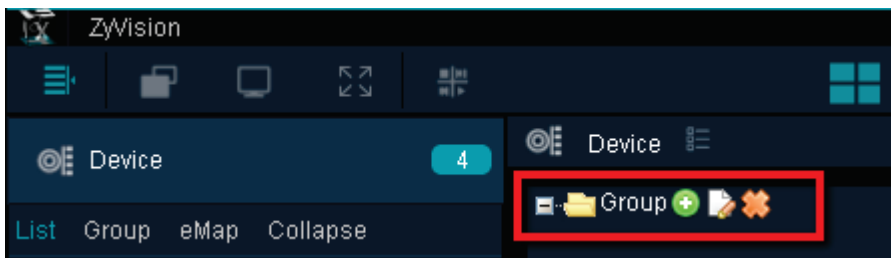
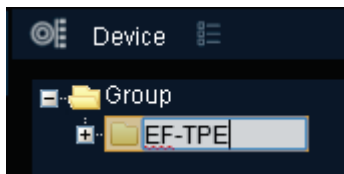

Figure 3-7

1. On the Device List setup page, click the **Group** button, and then click the Group folder on the Group List, the modification icons appears.



2. Click the **add node**  button and enter a name to add a node.



3. Drag a device from the Device List and drop it to the created group. You can drag multiple devices to a single group.

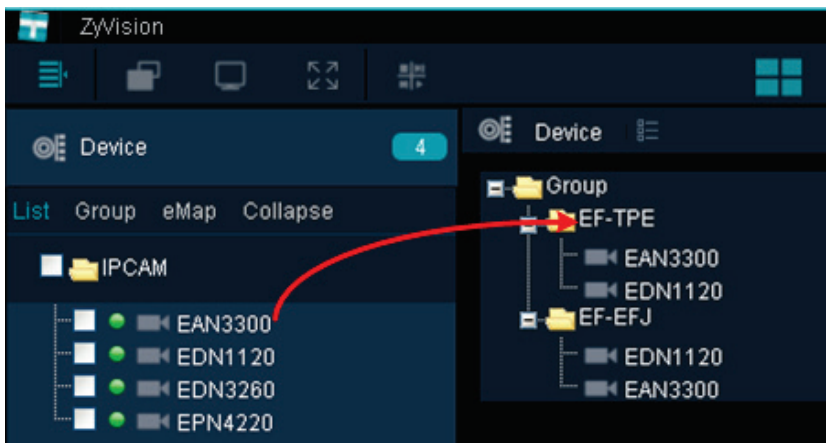

4. Click the **Save** button to save the settings.

3.2.3.2 Editing Device Configurations

To edit the added devices, on the Device List Setup page, click the  **Edit** icon, click the column you want to configure and input the setting. Click the **Update** button to save the settings.

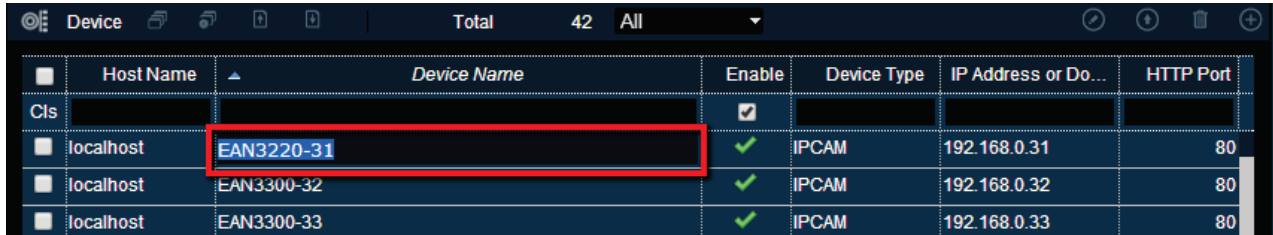

Host Name	Device Name	Enable	Device Type	IP Address or Do...	HTTP Port
localhost	EAN3220-31	<input checked="" type="checkbox"/>	IPCAM	192.168.0.31	80
localhost	EAN3300-32	<input checked="" type="checkbox"/>	IPCAM	192.168.0.32	80
localhost	EAN3300-33	<input checked="" type="checkbox"/>	IPCAM	192.168.0.33	80

Figure 3-8

3.2.3.3 Device Type List

You can add devices, image, message or even a Website to the system. On the Device List Setup page, click the Device Type List drop-down list to select a device type.

No.	Name	Description
1	IPCAM	IP camera.
2	DVR	EverFocus DVR.
3	NVR	EverFocus NVR.
4	Message	Display message for Text or Marquee mode.
5	RTSP	RTSP streaming URL.
6	Image	Picture (PNG, JPG, JPEG, GIF, TIFF).
7	Access	Access controller or reader.
8	Access Server	ENS200 Access management server.
9	XMS	EverFocus XMS server.
10	WEB	Web URL.

3.2.3.4 Adding Devices

You can manually or automatically add devices to the NVR. On the Device List Setup page, click the **Add** button, the Maintain page appears.

Manually Adding a Device

Select a device type from the Device Type drop-down list, enter the device information and click the **Save** button to save the settings. The device will be added to the Device List.

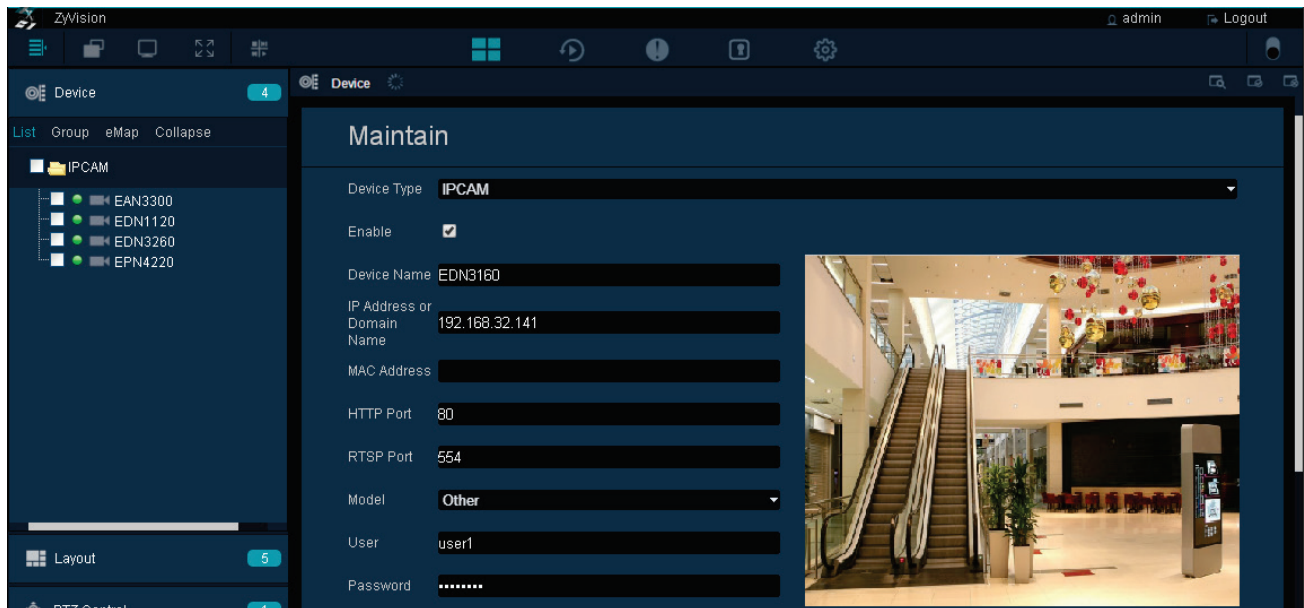

Figure 3-9

Automatically Adding Devices

On Figure 3-9, click the  **Auto Detection** icon to switch to the Auto Detection page.



Figure 3-10

1. Check the square beside the Device Name to select a desired device. (Note: If multiple devices have the same ID and Password, you can select multiple devices on this step).

2. Type the device ID and Password in the above columns.



3. Click the  **Apply to Select** icon to apply the input ID and Password to the selected devices.
4. Click the **Authentication** icon, the verified devices will be marked with a check mark.

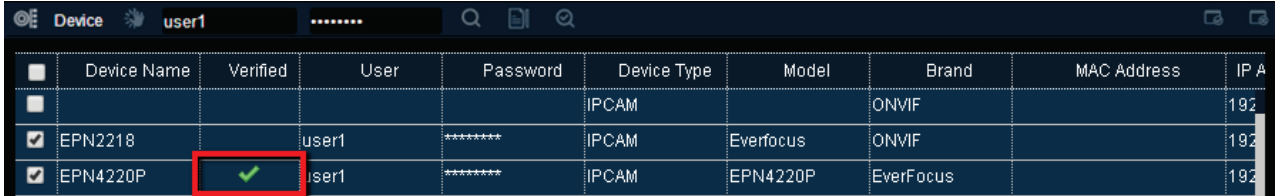





<input type="checkbox"/>	Device Name	Verified	User	Password	Device Type	Model	Brand	MAC Address	IP A
<input type="checkbox"/>					IPCAM		ONVIF		192
<input checked="" type="checkbox"/>	EPN2218		user1	*****	IPCAM	Everfocus	ONVIF		192
<input checked="" type="checkbox"/>	EPN4220P	<input checked="" type="checkbox"/>	user1	*****	IPCAM	EPN4220P	EverFocus		192

5. Click the **Save** button, the device will be listed on the Device List.

3.2.3.5 Device Indicator

The Device Indicator indicates the status of the devices.

	Status	Description
	Connected	Indicates the devices have been connected with streaming displayed.
	Recording	Indicates the live view recording (schedule record) is on.
	Event Triggered	Indicates an event occurs or an alarm is triggered.
	No Connection	Indicates there is no connection of this device.
	Disconnect	Indicates the devices have been disconnected.

3.2.4 Layout Setting

You can configure the layout on this page. On the Live View Window, click **Layout** from the left-side bar, select a layout by clicking on the desired layout, the selected layout should be appeared on the right-side window.

To add the devices to the layout cells, on the left-side bar, click **Device**, drag and drop the devices from the Device List to the layout cells.

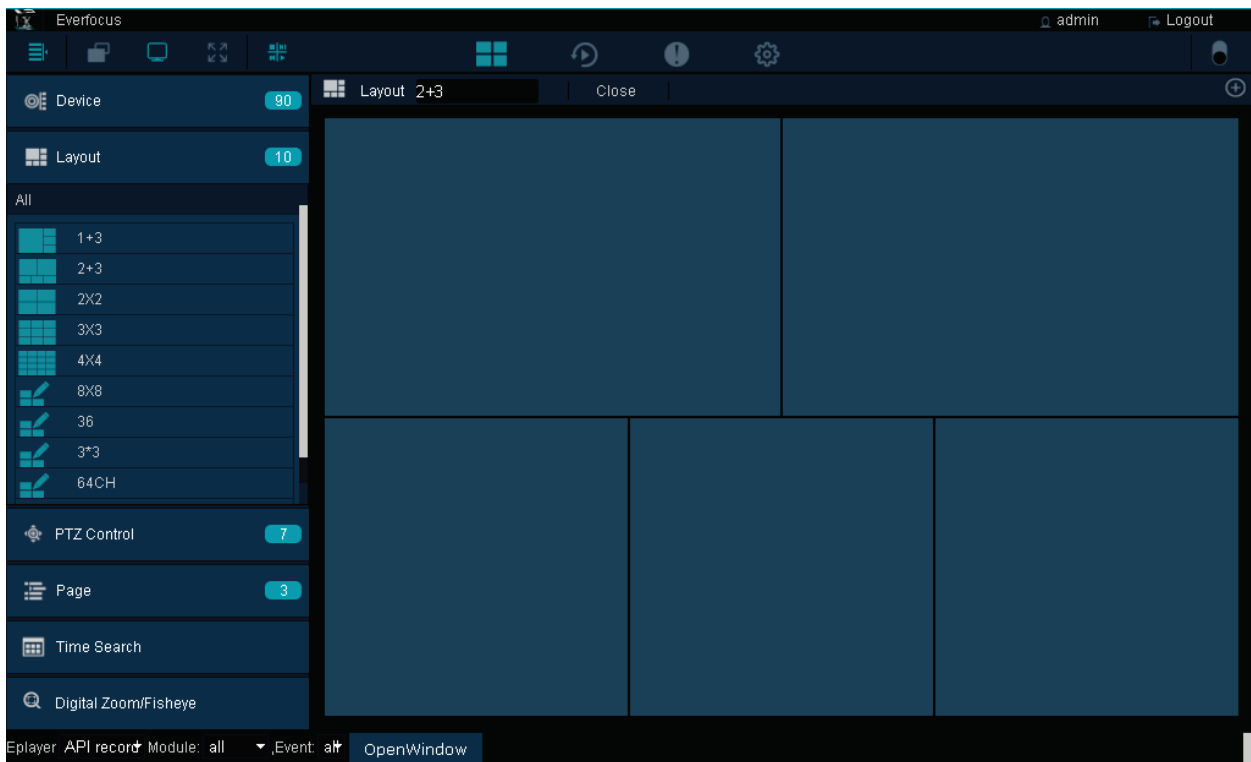
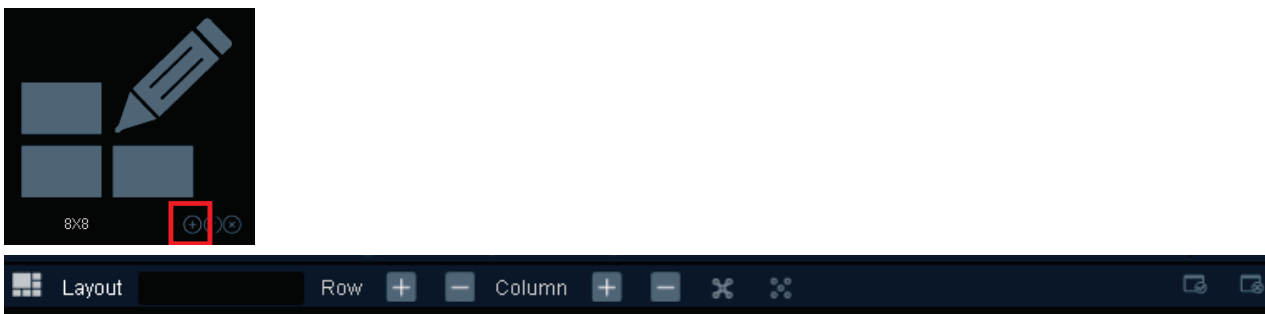

Figure 3-11

To create personalized layout, on the left-side bar, click the **10** **Layout Detail** button, select an editable layout and click the **Add** button, an edit bar should appear on the top of the window. Use the function buttons to add/delete/merge/separate layout cells. Click the **Save** icon to save the settings.



3.2.5 Page Setting

You can create multiple live view layouts and then save them as pages. Create a layout and then click the **Add** icon on the Live View Window. The layout will be saved in the Page List as a page.

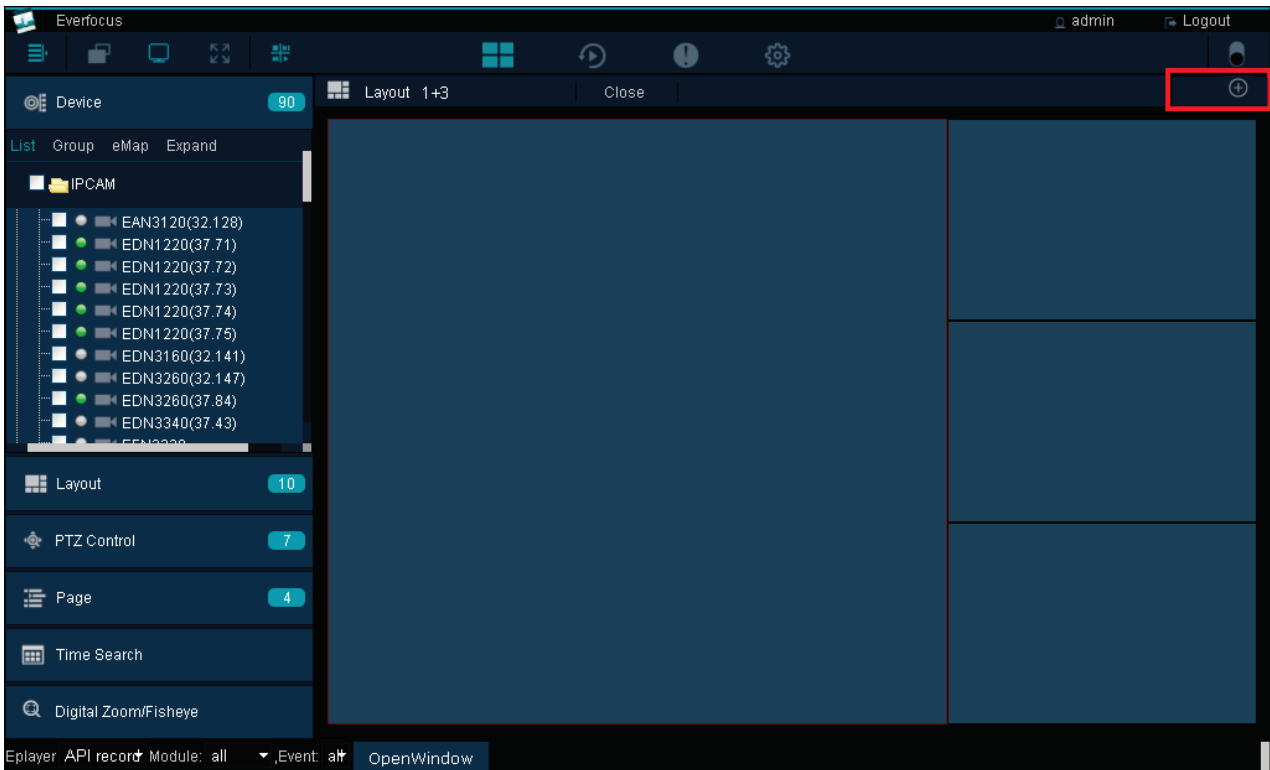
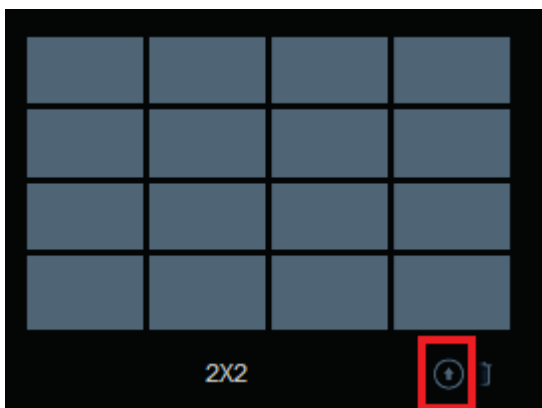

Figure 3-12

To modified pages, on the Live View Window, click the **Page Detail** button on the left-side bar and then click the **Update** button.



3.3 Recording

You can set up a weekly recording schedule for the connected devices to record the videos in your computer. The recordings will be saved in AVI files. You have to set up a recording path for the recordings before activating this function (see 3.3.1 *Setting up the Recording Path*).

On the Live View Window, click the **Setting** button, click the **Record & Play** menu bar on the left, click **Schedule**, the following Schedule page appears.



Figure 3-13

Recording Type buttons:

 : Continuous recordings only.

 : Event recordings only.

 : Continuous and Event recordings.

Note: For Event recordings, you have to configure the event settings in advance. On the Live View Window, click the **Setting** button and then click **Event** on the menu bar to enter the Event Setting page. For motion detection setting, please refer to 3.5.7 Motion Detect.

To add a recording schedule to the Schedule Name List:

1. Select a recording type by clicking on the Recording Type buttons.
2. Move the cursor on a desired time square, click and drag the cursor to set up the time period on each day. The squares will be displayed in blue/yellow/green to indicate which recording type has been applied to the time period.
3. Click the **Add** button and enter a name for the recording schedule.
4. The recording schedule should be listed in the Schedule Name List.

To apply a recording schedule to the desired devices:

1. Click the **Device List** button, select the desired devices and then click the **Save** button.

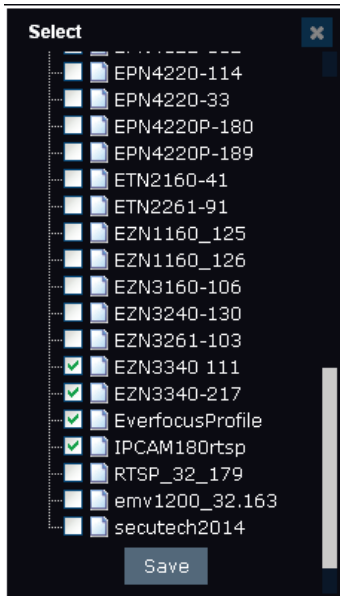

2. Select a desired recording schedule from the Schedule Name List drop-down list and then click the **Apply** button.

3.3.1 Setting up the Recording Path

On the Live View Window, click the **Setting** button, click the **User Setting** menu bar on the left, click **Local Save Settings**, the following page appears. Click the **Select** button in the **Save Recording in** field to select a path for the recordings. Click the **Apply** button to save the settings. You can also set up a path for the snapshot images in the **Save Snapshot in** field.

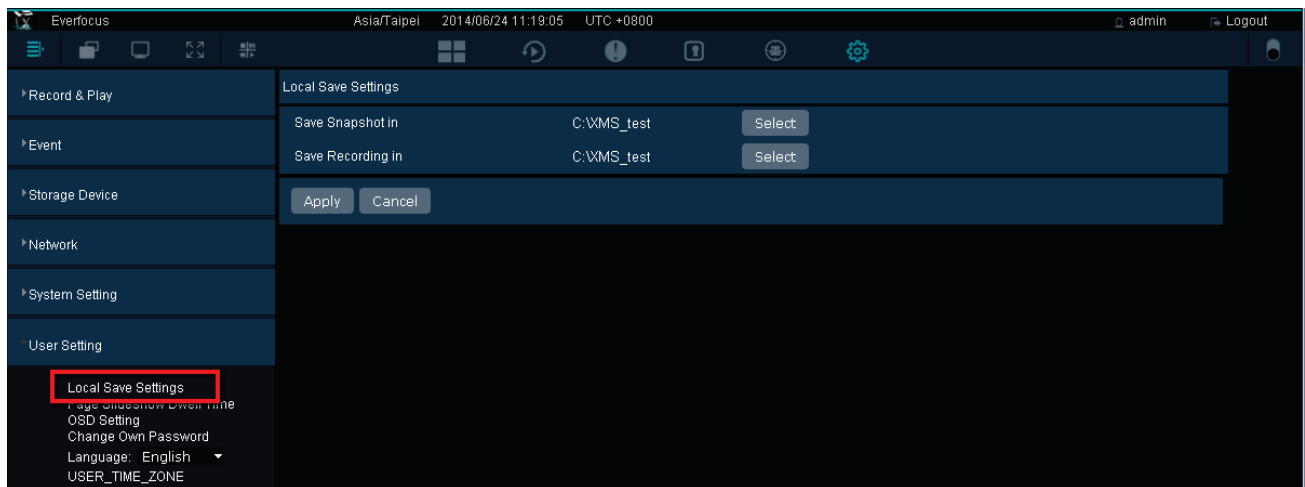

Figure 3-14

3.4 Quick Playback

You can play back the Live View recordings of the cameras stored in the client computer using the internal built-in player. On the Live View Window, click the **Option** button, the Live View Tool Bar appears on the top of the live view cell. Click the **Quick Playback** button, the playback bar appears on the bottom of the window. You can control the playback bar on this page.

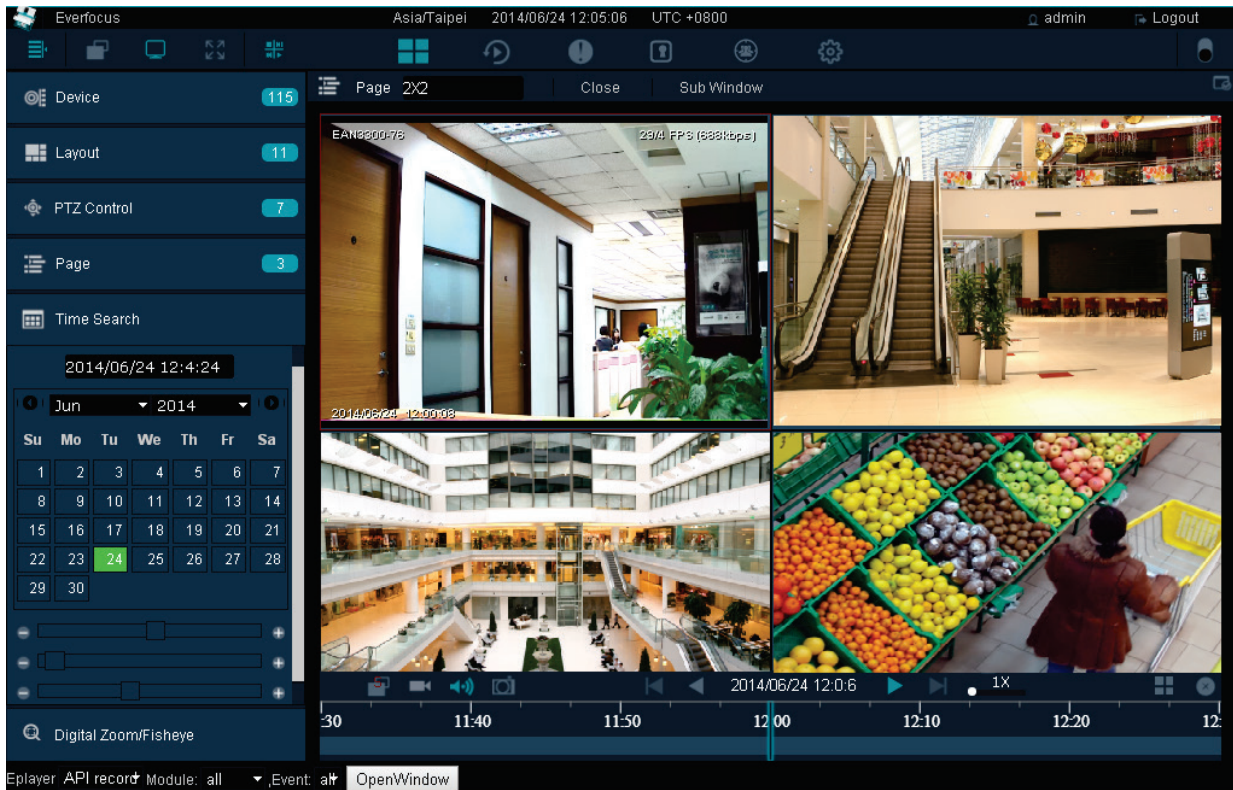

Figure 3-15

The Quick Playback function is designed to play back the recordings start from the pre-configured time. Before using the Quick Playback function, you have to configure the Playback settings in advance. On the Live View Window, click the **Setting** button, click **Record & Play** from the menu bar and click **Playback**, the Playback setup page appears. Enter the desired time for playing back the recording. Take the below image for example, if the current system clock time is 17:35:00, the start time for the playback recording will start from 17:34:00 (60 seconds ago from 17:35:00).

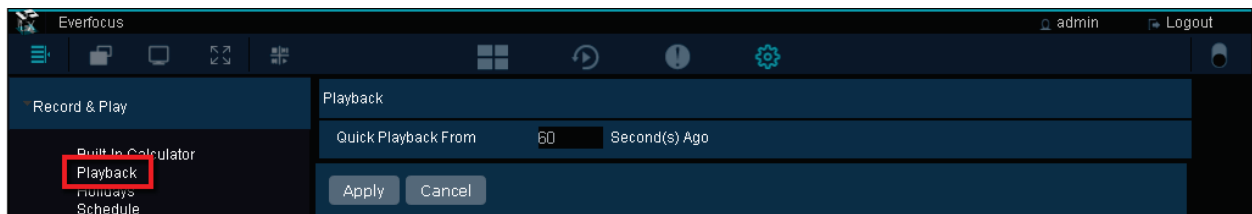

Figure 3-16

3.5 Setting

You can configure the system settings on this page. On the Live View Window, click the **Setting** button, a menu bar appears on the left side of the window. Enter each field to configure the settings.

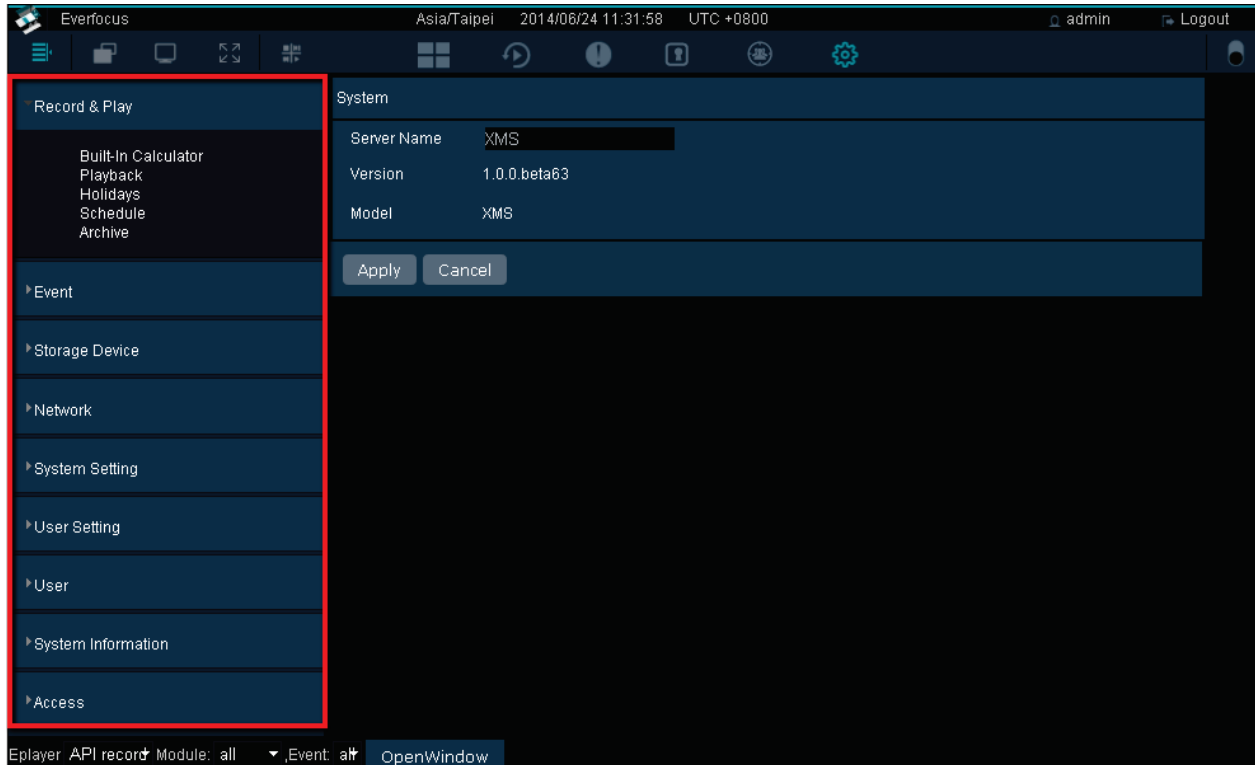

Figure 3-17

3.5.1 Date / Time

On the left-side menu bar, click **System Setting** and then click **Date/Time**. Enter the current date and time, and then click the **Apply** button to save the settings.

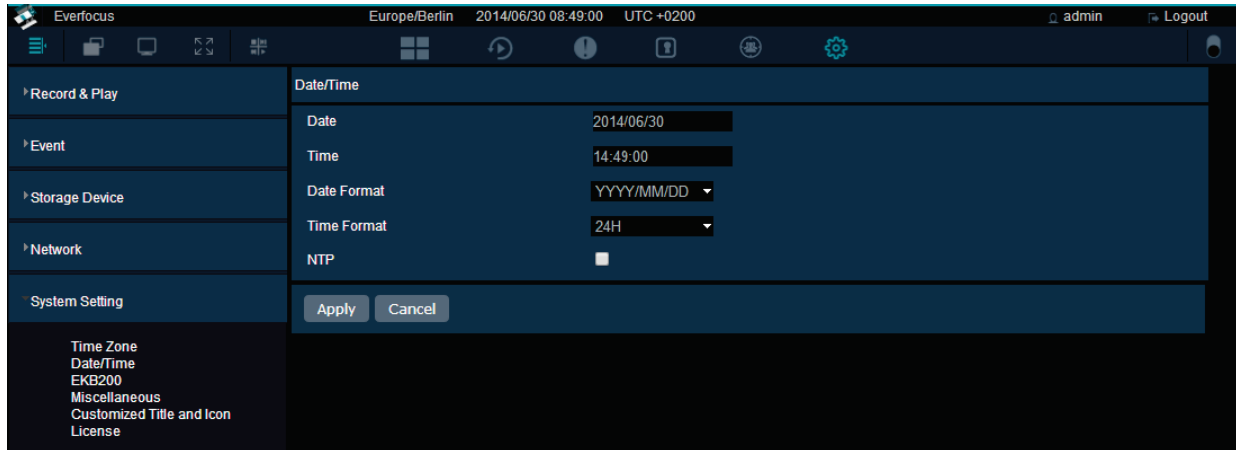

Figure 3-18

3.5.2 License

On the left-side menu bar, click **System Setting** and then click **License**. Enter the data, and then click the **Activate** button to activate the license.

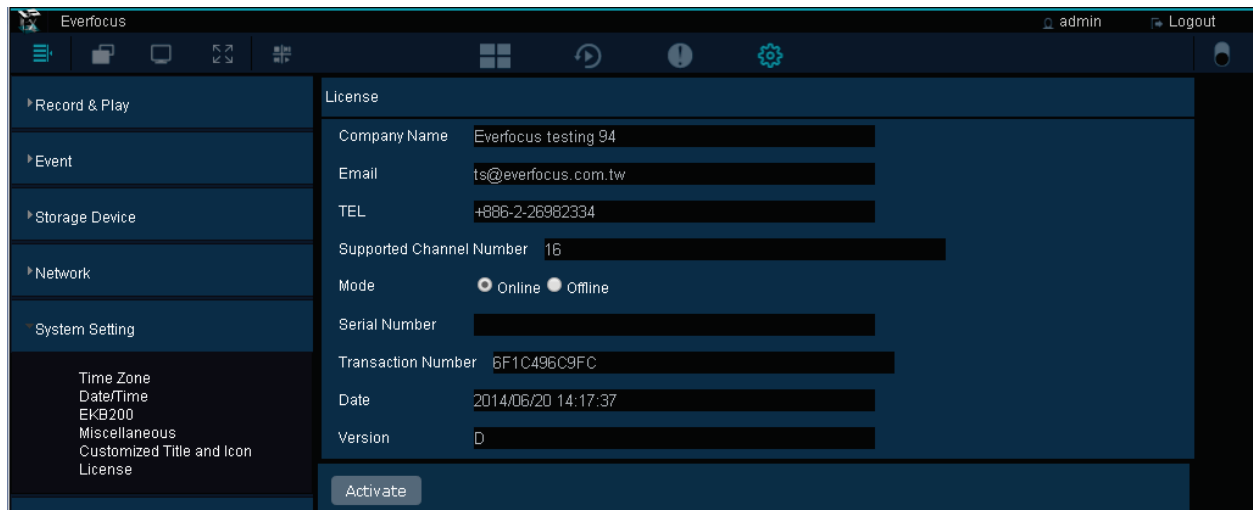

Figure 3-19

3.5.3 User Management

You can create multiple user accounts with different privileges using this page. On the left-side menu bar, click **User** and then click **User Management**. Click **Change Mode**, click the **Add** button to add a user, input the password for the user, select a user group from the drop-down list and then input the email address of the user. Click the **Save** button, the user should be listed in the User Management list.

Note that there are three group types for the user account: Administrator, Operator and Viewer. Each group type is applied with the fixed privileges as listed below.

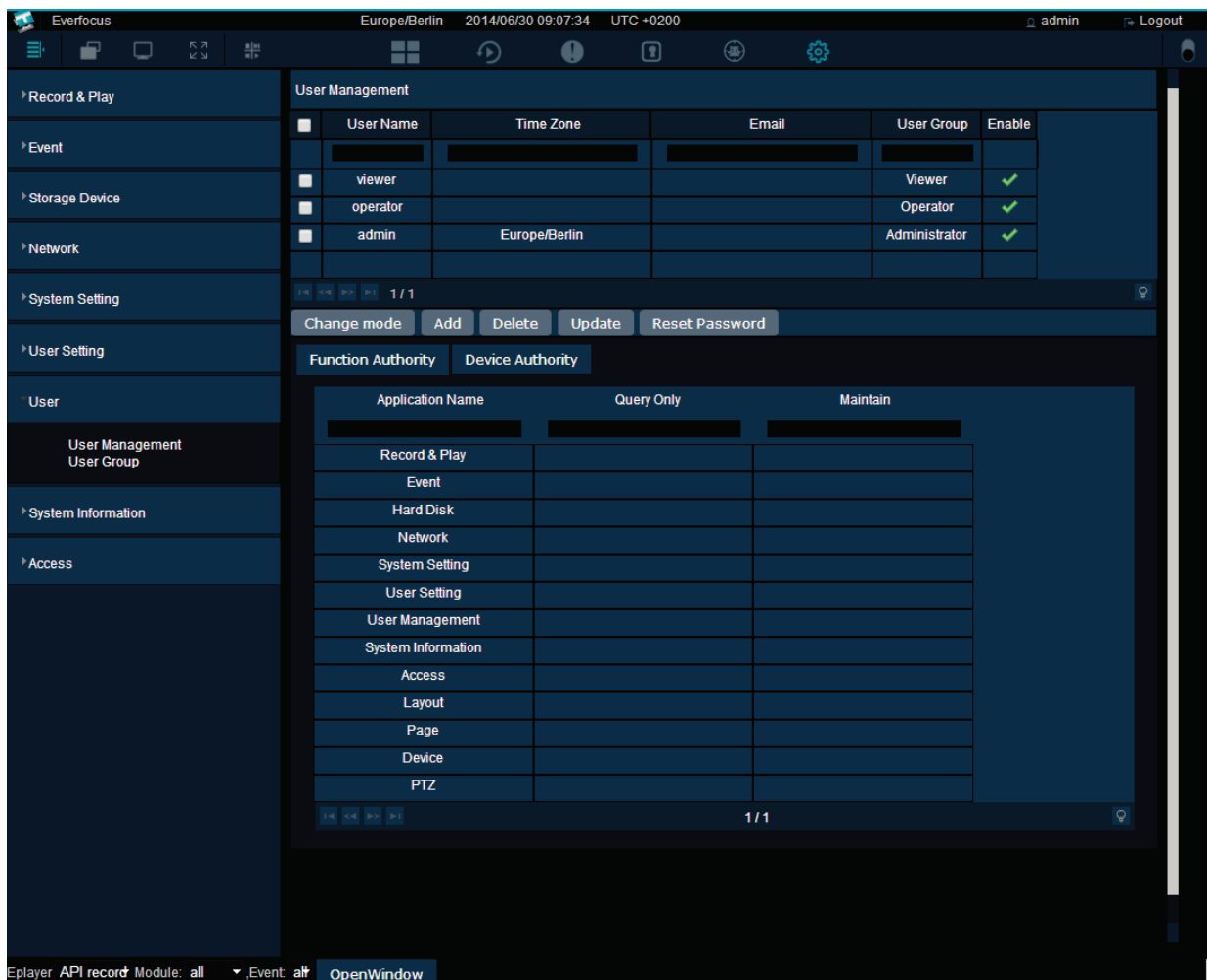

Figure 3-20

3.5.4 Recording Data Report

This Recording Data Report shows the recording status of all the devices. On the left-side menu bar, click **System Information** and then click **Recording Data Report**. Click to select a **Date** and **Time**, click **Related Device List** to select devices, and click **Query** to display the recording status report. You can click **By Minutes/ Second** or **By Hour** to show the report in different timeline formats.

Event: A yellow block represents only events are recorded during this time block.

Recording + Event: A green block represents the continuous and event recording during this time block.

Recording: A blue block indicates the continuous recording during this time block.

Abnormal: A red block may result from disconnection, power-loss or ongoing recording during this time block.

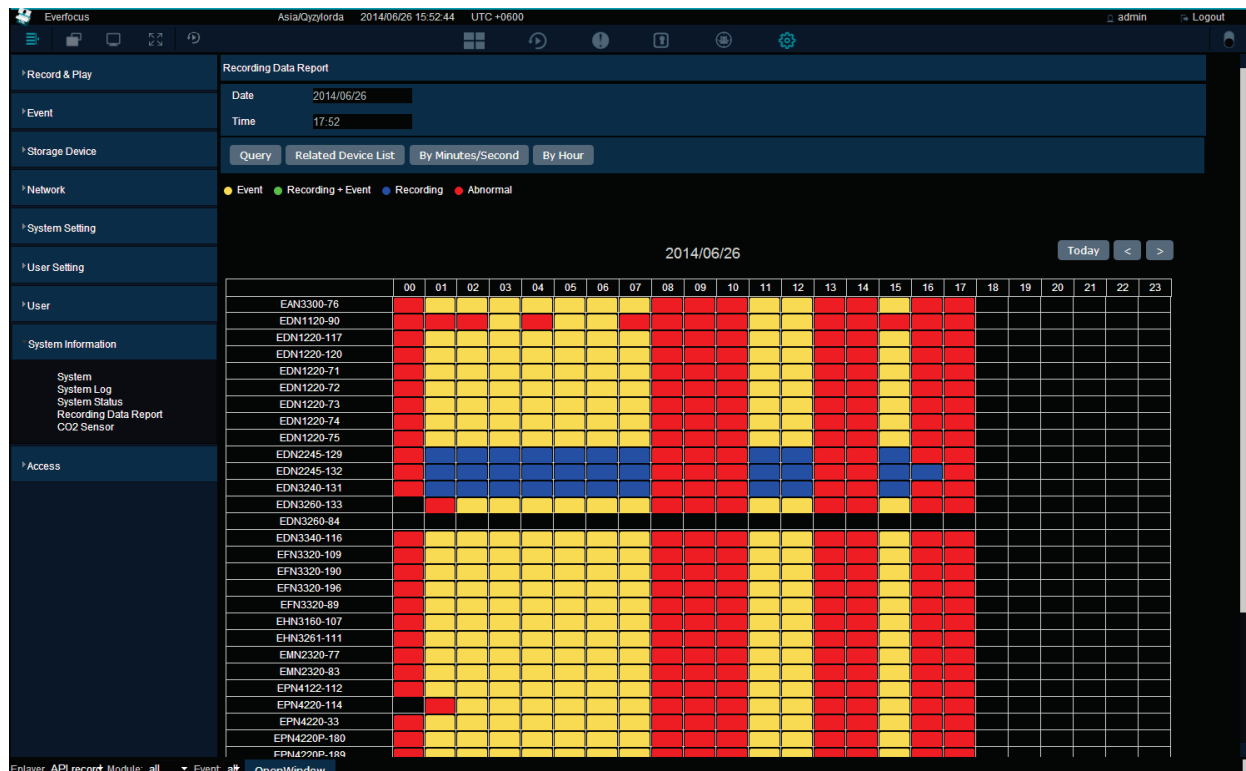

Figure 3-21

3.5.5 Disk Information

This Disk Information will automatically show the detailed information of all the installed hard disk drives, such as model name, disk type and capacity. On the left-side menu bar, click **Storage Device** and then click **Disk Information**.



Figure 3-22

3.5.6 Storage Device Management

You can manage all the storage devices on this page. On the left-side menu bar, click **Storage Device** and then click **Storage Device Management**. Click **Format** to format the HDD for the first time. (WARNING: This will effectively ERASE the ENTIRE hard disk!) Click **Add** to add a new group, enter a group name, and then drag and drop the disks from the Unused Group to the newly created group. Click **Apply** to group the disks.

Note that one disk can only be added to one group.

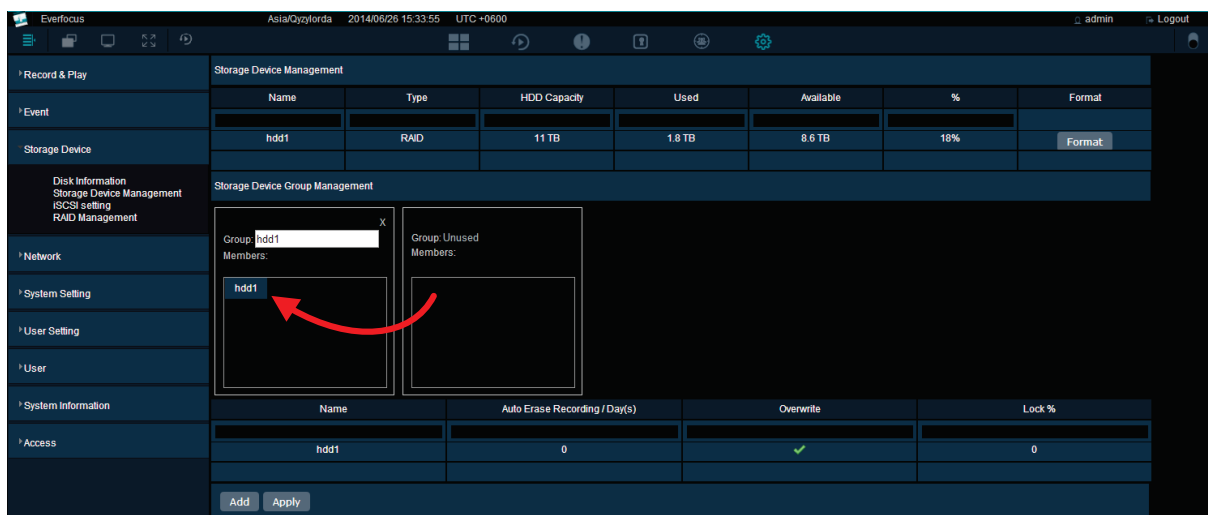

Figure 3-23

You can also configure the detailed settings for each group.

Name	Auto Erase Recording / Day(s)	Overwrite	Lock %
hdd1	0	<input checked="" type="checkbox"/>	0

Figure 3-24

Auto Erase Recording / Day(s): The hard disk will automatically erase video after it has been on the hard drive for the entered number of days.

Overwrite: Check the box to overwrite the hard disk when the capacity is used up to 99% (the capacity does not include the locked space of the disk).

Lock %: Enter a percentage for a write protected segment of the hard disk (will not be overwritten). However, this locked space is currently reserved.

For example, if you check the **Overwrite** box and you set 20% of the locked disk space, when the disk is used up to 99% of the remaining 80% unlocked space, it will start overwrite the disk.

To save the IP camera recording to this disk group, please see below:

1. Go to the Live View page by clicking the  **Live View** button, and then click  **Device Detail**.

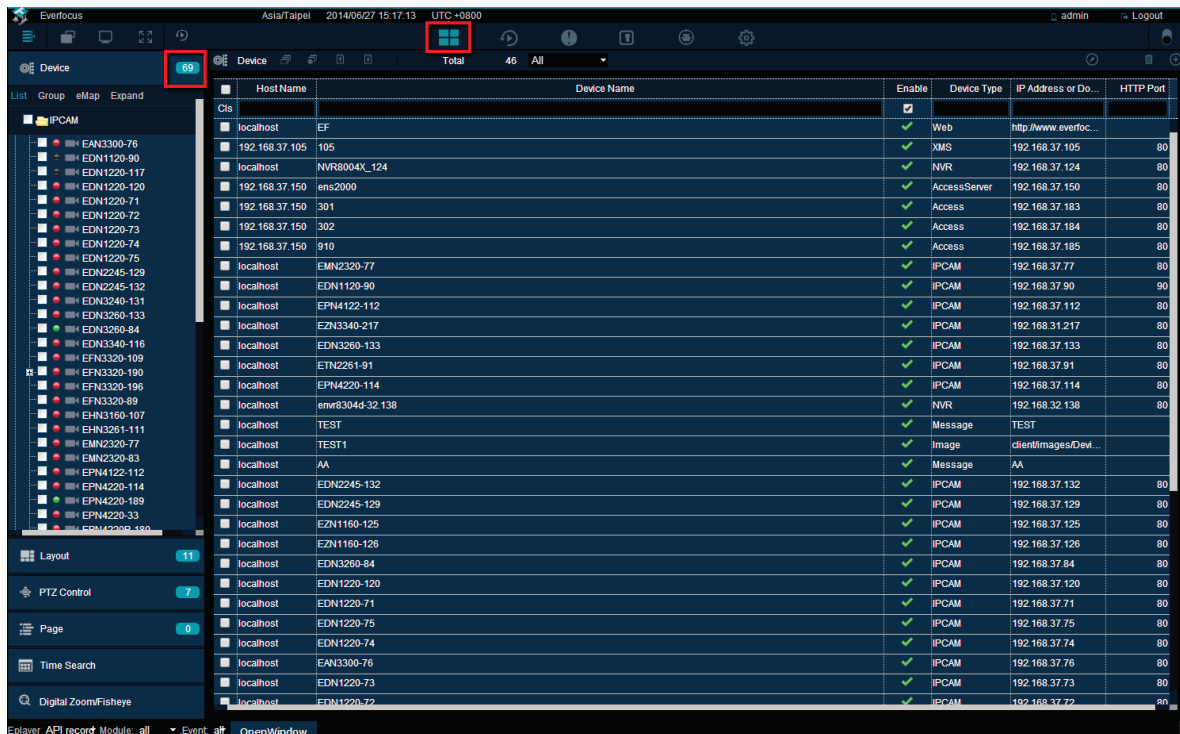

Figure 3-25

2. Double-click a device to display the device setting, and then click **Storage Device** to select a desired disk group.

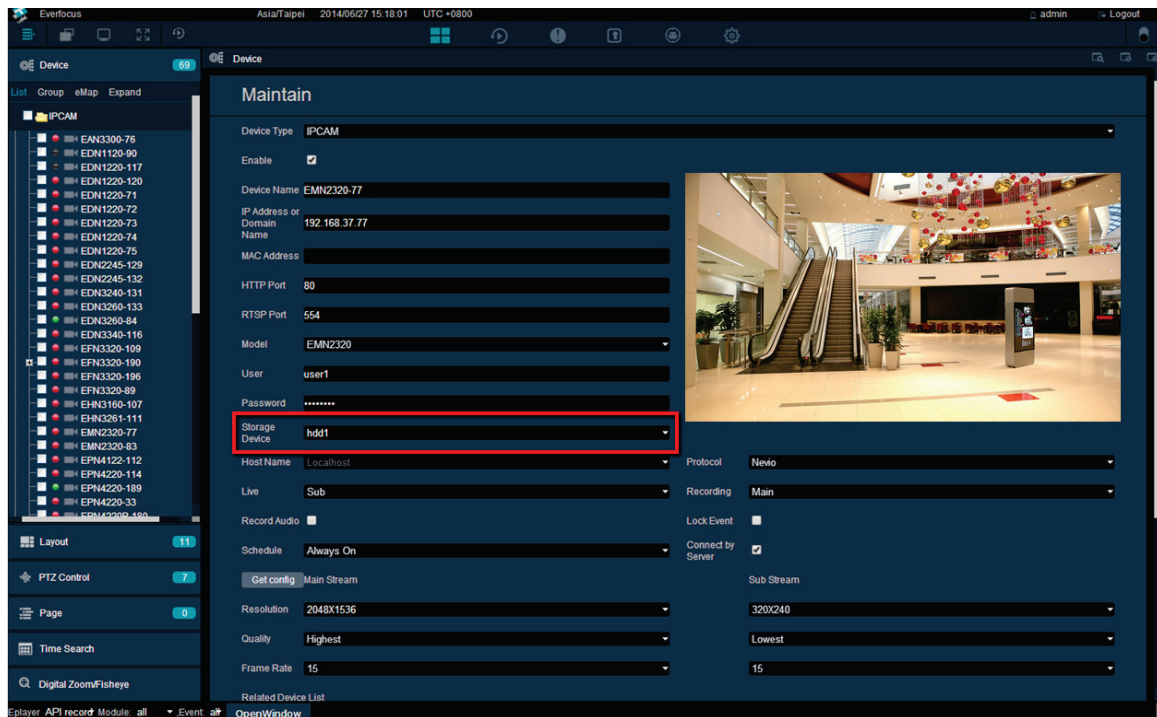



Figure 3-26

3. Click the  **Save** button on the upper-right corner of the page.

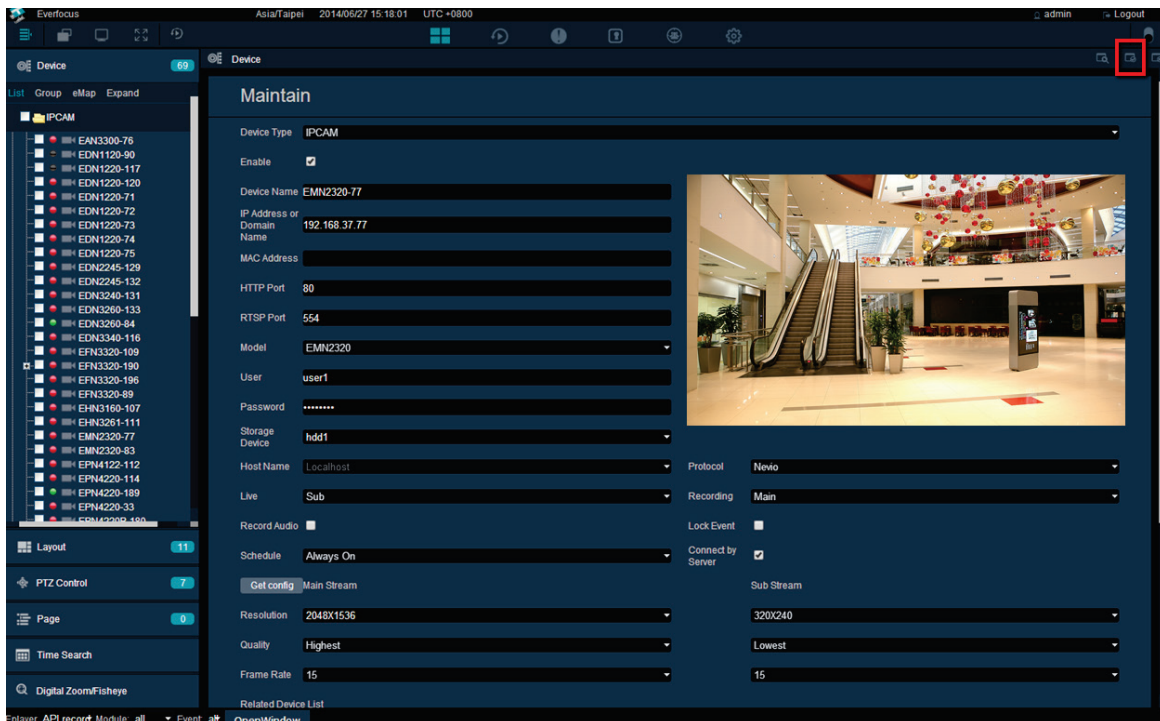

Figure 3-27

3.5.7 Motion Detect

You can set up the motion detection of the IP camera on this page. On the left-side menu bar, click **Event** and then click **Motion Detect**. Check the **Enable** box on the devices which you want to set up the motion detection setting, and then click **Edit Motion Grid** to bring up the motion setting page.

On the left side, click on a device or select multiple devices and its image will be displayed at the right side. Click and drag a rectangle on the image to set up a motion area, and the selected area will be highlighted in blue. You can only set up one motion area. Click **Apply** to save the setting.



Figure 3-28

4. Specifications

Model	Elite 2 NVR8004X
System	
Channels	Comes with 4 Licenses (Expandable to 16)
OS	Embedded Linux
View Mode	Can duplicate cameras with Digital Zoom/Digital PTZ views for each separately
Recording Modes	Continuous record, record by schedule, event trigger record, digital input trigger record
Recording Resolution	Up to full camera resolution
Compression Supported	H.264 / MJPEG
Audio	Bi-directional transmission, 1 audio channel per video channel (depending on specification of IP device)
Max Client Limit	Live View up to 128 Streams
Storage	
Internal HDD	4 SATA II HDD bays with Removable Hot Swap Trays
Video Storage	up to 12TB
Raid	0,1, 5, 10 configurable
Interface	
Network Interface	Gigabit RJ45 Ethernet Port x 2
Other Interface	USB 2.0 x 2; USB 3.0 x 2 (on back panel)
Alarm I/O	Dependent on supported camera
Function	
Event Trigger	Yes
Notification	Dependent on supported camera "On Screen Display" for event notification, Trigger alarm output , send email notification
E-Map	Supports E-map with device indicator
Bandwidth Monitor	Displayed in Client Screen
User Rights Management	Create unique user ID and password with user rights management for per camera live &/or playback access; restrict ability to backup and/or delete data
PTZ	PTZ Control of supported cameras
Digital PTZ	Can zoom to selected view on any camera
Recording Rate	Max 100Mbps, Max 30 FPS per camera

Multi-Channel	Live view any camera in any cameo. Duplicate cameras for digital PTZ view. Web Browser view up to 128 cameos.
Multi-Channel Playback:	Up to license limit/max 16 cameras simultaneous on screen
Search Function	Time/Date via calendar and time bar; Intelligent search with modes: general motion, missing object, camera occlusion, foreign object, signal lost
Video Export to:	Snapshot in JPEG format; video export in AVI format
Remote Video Access via Free Client Software	Live view: Max 128 cameos (up to 2 windows with up to 64 views on each monitor at 1 PC) Playback view: up to 16 cameras (replaces one Live View screen during playback at PC) PC Remote backup function (multiple channel backup up to 16 channels) Mobile phone/PDA/tablet: free app with live multi views (No limit for number of installations for all remote applications)
Remote Maintenance	Internet Explorer 9 and later, Firefox 4.0-9.0, Chrome (Windows version)
Remote Live View Control	Live view, preset/go, PTZ, remote I/O, snapshot, multi-view, digital PTZ, advanced E-map, bandwidth control
General	
Power	DC 19VDC , 4.74A
Power Consumption	90W max; AC to DC power supply included with NVR
Temperature	32°F~104°F
Housing	Compact Desktop Lockable front door
Dimensions	140 mm x 183 mm x 219 mm / 5.51" x 7.16" x 8.62"
Weight	2.97 kg / 6.55 lbs (without HDDs)
Certifications	CE, FCC

Remote Client System Minimum Requirement	
OS	Windows XP (32-bit) / Win7 (32 and 64-bit) / Mac OS X
CPU	Intel Core 2 Duo, 2.6GHz
RAM	1GB
LAN Transmission Speed	10/100/1000 Mbps (RJ45)
Web Client	Internet Explorer 9 and later, Firefox 4.0-9.0, Chrome (Windows version)
Mobile iViewer	iPhone, iPad, Android

EverFocus Electronics Corp.

EverFocus Taiwan:

12F, No.79, Sec. 1, Shin-Tai Wu Road,
Hsi-Chih, Taipei, Taiwan
TEL: +886 2 2698 2334
FAX: +886 2 2698 2380
www.everfocus.com.tw
marketing@everfocus.com.tw

EverFocus China - Beijing:

Room 609, Technology Trade Building,
Shangdi Information Industry Base,
Haidian District, Beijing 100085, China
TEL: +86 10 6297 3336~39
FAX: +86 10 6297 1423
www.everfocus.com.cn
marketing@everfocus.com.cn

EverFocus USA - California:

1801 Highland Avenue, Unit A, Duarte, CA 91010, USA
TEL: +1 626 844 8888
FAX: +1 626 844 8838
www.everfocus.com
sales@everfocus.com

EverFocus Japan:

3F Kuramochi, Building II 2-2-3
Koto-Bashi, Sumida-ku, Tokyo, 130-0022, Japan
TEL: +81 3 5625 8188
FAX: +81 3 5625 8189
www.everfocus.co.jp
info@everfocus.co.jp

EverFocus India:

UBS, 629/1243, 1st Floor, G Block, Behind Teacher's
Colony, Bandra Kurla Complex, Bandra (E),
Mumbai 400 051, India
TEL: +91 22 6726 4500
FAX: +91 22 6726 4518
www.everfocus.in
sales@everfocus.in

EverFocus Europe - Germany:

Albert-Einstein-Strasse 1, D-46446
Emmerich, Germany
TEL: +49 2822 93940
FAX: +49 2822 939495
www.everfocus.de
sales@everfocus.de

EverFocus China - Shenzhen:

4F, No. 2, D4 Building, Wan Yelong
Industrial Park, Tangtou Road, Shiyan,
Baoan, Shenzhen, Guangdong 518101, China
TEL: +86 755 2765 1313
FAX: +86 755 2765 0337
www.everfocus.com.cn
marketing@everfocus.com.cn

EverFocus USA - New York:

415 Oser Avenue, Unit S, Hauppauge, NY 11788, USA
TEL: +1 631 436 5070
FAX: +1 631 436 5027
www.everfocus.com
sales@everfocus.com

EverFocus China - Shanghai:

Room 403, Ruijin Business Center, No.96,
Zhaojiabang Road, Luwan district, Shanghai 200020,
China
TEL: +86 21 6471 2229 / 6471 2291
FAX: +86 21 6471 0566
www.everfocus.com.cn
marketing@everfocus.com.cn

	<p>Your EverFocus product is designed and manufactured with high quality materials and components which can be recycled and reused.</p> <p>This symbol means that electrical and electronic equipment, at their end-of-life, should be disposed of separately from your household waste.</p> <p>Please, dispose of this equipment at your local community waste collection/recycling centre.</p> <p>In the European Union there are separate collection systems for used electrical and electronic product.</p> <p>Please, help us to conserve the environment we live in!</p>	<p>Ihr EverFocus Produkt wurde entwickelt und hergestellt mit qualitativ hochwertigen Materialien und Komponenten, die recycelt und wieder verwendet werden können.</p> <p>Dieses Symbol bedeutet, dass elektrische und elektronische Geräte am Ende ihrer Nutzungsdauer vom Hausmüll getrennt entsorgt werden sollen.</p> <p>Bitte entsorgen Sie dieses Gerät bei Ihrer örtlichen kommunalen Sammelstelle oder im Recycling Centre.</p> <p>Helfen Sie uns bitte, die Umwelt zu erhalten, in der wir leben!</p>
---	--	---



P/N: 4605PNV804B063A