

# SUPER<sup>®</sup>

## SC514 SERIES



SC514-441

SC514-R400C

SC514-R400W

## USER'S MANUAL

Revision 1.0

The information in this User's Manual has been carefully reviewed and is believed to be accurate. The vendor assumes no responsibility for any inaccuracies that may be contained in this document, makes no commitment to update or to keep current the information in this manual, or to notify any person or organization of the updates. **Please Note: For the most up-to-date version of this manual, please see our web site at [www.supermicro.com](http://www.supermicro.com).**

Super Micro Computer, Inc. ("Supermicro") reserves the right to make changes to the product described in this manual at any time and without notice. This product, including software and documentation, is the property of Supermicro and/or its licensors, and is supplied only under a license. Any use or reproduction of this product is not allowed, except as expressly permitted by the terms of said license.

IN NO EVENT WILL SUPERMICRO BE LIABLE FOR DIRECT, INDIRECT, SPECIAL, INCIDENTAL, SPECULATIVE OR CONSEQUENTIAL DAMAGES ARISING FROM THE USE OR INABILITY TO USE THIS PRODUCT OR DOCUMENTATION, EVEN IF ADVISED OF THE POSSIBILITY OF SUCH DAMAGES. IN PARTICULAR, SUPERMICRO SHALL NOT HAVE LIABILITY FOR ANY HARDWARE, SOFTWARE, OR DATA STORED OR USED WITH THE PRODUCT, INCLUDING THE COSTS OF REPAIRING, REPLACING, INTEGRATING, INSTALLING OR RECOVERING SUCH HARDWARE, SOFTWARE, OR DATA.

Any disputes arising between manufacturer and customer shall be governed by the laws of Santa Clara County in the State of California, USA. The State of California, County of Santa Clara shall be the exclusive venue for the resolution of any such disputes. Super Micro's total liability for all claims will not exceed the price paid for the hardware product.

FCC Statement: This equipment has been tested and found to comply with the limits for a Class A digital device pursuant to Part 15 of the FCC Rules. These limits are designed to provide reasonable protection against harmful interference when the equipment is operated in a commercial environment. This equipment generates, uses, and can radiate radio frequency energy and, if not installed and used in accordance with the manufacturer's instruction manual, may cause harmful interference with radio communications. Operation of this equipment in a residential area is likely to cause harmful interference, in which case you will be required to correct the interference at your own expense.

California Best Management Practices Regulations for Perchlorate Materials: This Perchlorate warning applies only to products containing CR (Manganese Dioxide) Lithium coin cells. "Perchlorate Material-special handling may apply. See [www.dtsc.ca.gov/hazardouswaste/perchlorate](http://www.dtsc.ca.gov/hazardouswaste/perchlorate)"

**WARNING: Handling of lead solder materials used in this product may expose you to lead, a chemical known to the State of California to cause birth defects and other reproductive harm.**

Manual Revision 1.0

Release Date: December 30, 2014

Unless you request and receive written permission from Super Micro Computer, Inc., you may not copy any part of this document.

Information in this document is subject to change without notice. Other products and companies referred to herein are trademarks or registered trademarks of their respective companies or mark holders.

Copyright © 2014 by Super Micro Computer, Inc.  
All rights reserved.

**Printed in the United States of America**



## Preface

### About this Manual

This manual is written for professional system integrators and PC technicians. It provides information for the installation and use of the chassis. Installation and maintenance should be performed by experienced technicians only.

This document lists compatible parts available when this document was published. Refer to the Supermicor web site for updates on supported parts and configurations..

### Warnings

Special attention should be given to the following symbols used in this manual.



**Warning!** Indicates important information given to prevent equipment/ property damage or personal injury.



**Warning!** Indicates high voltage may be encountered when performing a procedure.

## Contents

Contacting Supermicro .....	6
<b>Chapter 1 Introduction.....</b>	<b>1-1</b>
1-1 Overview .....	1-1
1-2 Shipping List.....	1-1
1-3 Contacting Supermicro.....	1-2
1-4 Returning Merchandise for Service.....	1-3
<b>Chapter 2 Standardized Warning Statements for AC/DC Systems.....</b>	<b>2-1</b>
About Standardized Warning Statements .....	2-1
Warning Definition .....	2-1
Installation Instructions.....	2-4
Circuit Breaker .....	2-5
Power Disconnection Warning .....	2-6
Equipment Installation .....	2-8
Restricted Area.....	2-9
Battery Handling.....	2-10
Redundant Power Supplies .....	2-12
Backplane Voltage .....	2-13
Comply with Local and National Electrical Codes.....	2-14
Product Disposal .....	2-15
Hot Swap Fan Warning.....	2-16
DC Power Supply .....	2-18
DC Power Disconnection .....	2-20
Hazardous Voltage or Energy Present on DC Power Terminals .....	2-21
<b>Chapter 3 Chassis Components.....</b>	<b>3-1</b>
3-1 Overview .....	3-1
3-2 Components.....	3-1
Drives .....	3-1
Fans .....	3-1
Mounting Rails .....	3-1
Power Supply .....	3-1
Air Shroud (Optional) .....	3-2
3-3 Where to get Replacement Components.....	3-2
<b>Chapter 4 System Interface.....</b>	<b>4-1</b>
4-1 Overview .....	4-1
4-2 Control Panel Buttons .....	4-2
4-3 Control Panel LEDs .....	4-2
4-4 Power Supply LEDs .....	4-4

---

<b>Chapter 5 Chassis Setup and Maintenance .....</b>	<b>5-1</b>
5-1 Overview .....	5-1
5-2 Removing Power from the System .....	5-1
5-3 Removing the Chassis Cover .....	5-2
5-4 Installing Hard Drives .....	5-3
SC514-441 Model .....	5-3
SC514-R400C and -R400W Models .....	5-6
5-5 Installing the Motherboard .....	5-7
Installing the I/O Shield .....	5-7
Permanent and Optional Standoffs .....	5-8
Motherboard Installation .....	5-9
5-6 Installing Expansion Cards .....	5-10
5-7 Checking the Airflow .....	5-11
Installation Complete .....	5-11
5-8 System Fans .....	5-12
5-9 Power Supply .....	5-13
<b>Chapter 6 Rack Installation .....</b>	<b>6-1</b>
6-1 Overview .....	6-1
6-2 Unpacking the System .....	6-1
6-3 Preparing for Setup .....	6-1
Choosing a Setup Location .....	6-1
Rack Precautions .....	6-2
General Server Precautions .....	6-2
Rack Mounting Considerations .....	6-2
Ambient Operating Temperature .....	6-2
Reduced Airflow .....	6-3
Mechanical Loading .....	6-3
Circuit Overloading .....	6-3
Reliable Ground .....	6-3
Identifying the Sections of the Rack Rails .....	6-4
Locking Tabs .....	6-4
Installing The Inner Rail .....	6-5
Outer Rack Rails .....	6-6
<b>Appendix A SC514 Chassis Cables .....</b>	<b>A-1</b>
<b>Appendix B Power Supply Specifications .....</b>	<b>B-1</b>

## Contacting Supermicro

### Headquarters

Address: Super Micro Computer, Inc.  
980 Rock Ave.  
San Jose, CA 95131 U.S.A.

Tel: +1 (408) 503-8000

Fax: +1 (408) 503-8008

Email: [marketing@supermicro.com](mailto:marketing@supermicro.com) (General Information)  
[support@supermicro.com](mailto:support@supermicro.com) (Technical Support)

Web Site: [www.supermicro.com](http://www.supermicro.com)

### Europe

Address: Super Micro Computer B.V.  
Het Sterrenbeeld 28, 5215 ML  
's-Hertogenbosch, The Netherlands

Tel: +31 (0) 73-6400390

Fax: +31 (0) 73-6416525

Email: [sales@supermicro.nl](mailto:sales@supermicro.nl) (General Information)  
[support@supermicro.nl](mailto:support@supermicro.nl) (Technical Support)  
[rma@supermicro.nl](mailto:rma@supermicro.nl) (Customer Support)

Web Site: [www.supermicro.nl](http://www.supermicro.nl)

### Asia-Pacific

Address: Super Micro Computer, Inc.  
3F, No. 150, Jian 1st Rd.  
Zhonghe Dist., New Taipei City 235  
Taiwan (R.O.C)

Tel: +886-(2) 8226-3990

Fax: +886-(2) 8226-3992

Email: [support@supermicro.com.tw](mailto:support@supermicro.com.tw)

Web Site: [www.supermicro.com.tw](http://www.supermicro.com.tw)

# Chapter 1

## Introduction

### 1-1 Overview

Supermicro's SC514 1U cost-effective chassis, features a short depth of less than 16.9" and is designed to optimize resources while providing high performance. Optimized for dual-processor or single-processor motherboards, the SC514 features an advanced thermal design for highly efficient cooling and quiet operation with up to six 4cm counter-rotating cooling fans, and supporting a selection of high-efficiency power supplies to fit the desired application. Toolless serviceability and quick release sliding rails are also available for use in HPC and data center environments.

### 1-2 Shipping List

Please visit the following link for the latest shipping lists and part numbers for your particular chassis model. [www.supermicro.com](http://www.supermicro.com)

Model	HDD	I/O Slots	Power Supply
SC514-441	1x Fixed 3.5" or 2x Fixed 2.5"	Up to 2x FH	440W/480W
SC514-R400C	2x Fixed 2.5"	1x FH	400W (Redundant)
SC514-R400W	2x Fixed 2.5"	2x FH and 1x LP	400W (Redundant)

Legend:

FH: Full-height

LP: Low-profile

## 1-3 Contacting Supermicro

### Headquarters

Address: Super Micro Computer, Inc.  
980 Rock Ave.  
San Jose, CA 95131 U.S.A.

Tel: +1 (408) 503-8000

Fax: +1 (408) 503-8008

Email: [marketing@supermicro.com](mailto:marketing@supermicro.com) (General Information)  
[support@supermicro.com](mailto:support@supermicro.com) (Technical Support)

Website: [www.supermicro.com](http://www.supermicro.com)

### Europe

Address: Super Micro Computer B.V.  
Het Sterrenbeeld 28, 5215 ML  
's-Hertogenbosch, The Netherlands

Tel: +31 (0) 73-6400390

Fax: +31 (0) 73-6416525

Email: [sales@supermicro.nl](mailto:sales@supermicro.nl) (General Information)  
[support@supermicro.nl](mailto:support@supermicro.nl) (Technical Support)  
[rma@supermicro.nl](mailto:rma@supermicro.nl) (Customer Support)

Website: [www.supermicro.nl](http://www.supermicro.nl)

### Asia-Pacific

Address: Super Micro Computer, Inc.  
3F, No. 150, Jian 1st Rd.  
Zhonghe Dist., New Taipei City 235  
Taiwan (R.O.C)

Tel: +886-(2) 8226-3990

Fax: +886-(2) 8226-3992

Email: [support@supermicro.com.tw](mailto:support@supermicro.com.tw)

Website: [www.supermicro.com.tw](http://www.supermicro.com.tw)

## 1-4 Returning Merchandise for Service

A receipt or copy of your invoice marked with the date of purchase is required before any warranty service will be rendered. You can obtain service by calling your vendor for a Returned Merchandise Authorization (RMA) number. When returning to the manufacturer, the RMA number should be prominently displayed on the outside of the shipping carton, and mailed prepaid or hand-carried. Shipping and handling charges will be applied for all orders that must be mailed when service is complete.

For faster service, RMA authorizations may be requested online (<http://www.supermicro.com/support/rma/>).

Whenever possible, repack the chassis in the original Supermicro carton, using the original packaging material. If these are no longer available, be sure to pack the chassis securely, using packaging material to surround the chassis so that it does not shift within the carton and become damaged during shipping.

This warranty only covers normal consumer use and does not cover damages incurred in shipping or from failure due to the alteration, misuse, abuse or improper maintenance of products.

During the warranty period, contact your distributor first for any product problems.

## Notes



## Chapter 2

# Standardized Warning Statements for AC/DC Systems

## 2-1 About Standardized Warning Statements

The following statements are industry standard warnings, provided to warn the user of situations which have the potential for bodily injury. Should you have questions or experience difficulty, contact Supermicro's Technical Support department for assistance. Only certified technicians should attempt to install or configure components.

Read this appendix in its entirety before installing or configuring components in the Supermicro chassis.

These warnings may also be found on our web site at [http://www.supermicro.com/about/policies/safety\\_information.cfm](http://www.supermicro.com/about/policies/safety_information.cfm).

### Warning Definition



#### Warning!

This warning symbol means danger. You are in a situation that could cause bodily injury. Before you work on any equipment, be aware of the hazards involved with electrical circuitry and be familiar with standard practices for preventing accidents.

#### 警告の定義

この警告サインは危険を意味します。

人身事故につながる可能性がありますので、いずれの機器でも動作させる前に、電気回路に含まれる危険性に注意して、標準的な事故防止策に精通して下さい。

此警告符号代表危險。

您正处于可能受到严重伤害的工作环境中。在您使用设备开始工作之前，必须充分意识到触电的危险，并熟练掌握防止事故发生的标准工作程序。请根据每项警告结尾的声明号码找到此设备的安全性警告说明的翻译文本。

此警告符號代表危險。

您正處於可能身體可能會受損傷的工作環境中。在您使用任何設備之前，請注意觸電的危險，並且要熟悉預防事故發生的標準工作程序。請依照每一注意事項後的號碼找到相關的翻譯說明內容。

## Warnung

### WICHTIGE SICHERHEITSHINWEISE

Dieses Warnsymbol bedeutet Gefahr. Sie befinden sich in einer Situation, die zu Verletzungen führen kann. Machen Sie sich vor der Arbeit mit Geräten mit den Gefahren elektrischer Schaltungen und den üblichen Verfahren zur Vorbeugung vor Unfällen vertraut. Suchen Sie mit der am Ende jeder Warnung angegebenen Anweisungsnummer nach der jeweiligen Übersetzung in den übersetzten Sicherheitshinweisen, die zusammen mit diesem Gerät ausgeliefert wurden.

BEWAHREN SIE DIESE HINWEISE GUT AUF.

### INSTRUCCIONES IMPORTANTES DE SEGURIDAD

Este símbolo de aviso indica peligro. Existe riesgo para su integridad física. Antes de manipular cualquier equipo, considere los riesgos de la corriente eléctrica y familiarícese con los procedimientos estándar de prevención de accidentes. Al final de cada advertencia encontrará el número que le ayudará a encontrar el texto traducido en el apartado de traducciones que acompaña a este dispositivo.

GUARDE ESTAS INSTRUCCIONES.

### IMPORTANTES INFORMATIONS DE SÉCURITÉ

Ce symbole d'avertissement indique un danger. Vous vous trouvez dans une situation pouvant entraîner des blessures ou des dommages corporels. Avant de travailler sur un équipement, soyez conscient des dangers liés aux circuits électriques et familiarisez-vous avec les procédures couramment utilisées pour éviter les accidents. Pour prendre connaissance des traductions des avertissements figurant dans les consignes de sécurité traduites qui accompagnent cet appareil, référez-vous au numéro de l'instruction situé à la fin de chaque avertissement.

CONSERVEZ CES INFORMATIONS.

## תקנת הצהרות אזהרה

הצהרות הבאות הן אזהרות על פי תקני התעשייה, על מנת להזהיר את המשתמש מפני חבלה פיזית אפשרית. במידה ויש שאלות או היתקלות בבעיה כלשהי, יש ליצור קשר עם מחלקת תמיכה טכנית של סופרמיקרו. טכנאים מוסמכים בלבד רשאים להתקין או להגדיר את הרכיבים.

יש לקרוא את הנספח במלואו לפני התקנת או הגדרת הרכיבים במארוזי סופרמיקרו.

تحذير! هذا الرمز يعني خطر انك في حالة يمكن أن تتسبب في اصابة جسدية .  
قبل أن تعمل على أي معدات، كن على علم بالمخاطر الناجمة عن الدوائر  
الكهربائية  
وكن على دراية بالممارسات الوقائية لمنع وقوع أي حوادث  
استخدم رقم البيان المنصوص في نهاية كل تحذير للعثور ترجمتها

안전을 위한 주의사항

경고!

이 경고 기호는 위험이 있음을 알려 줍니다. 작업자의 신체에 부상을 야기 할 수 있는 상태에 있게 됩니다. 모든 장비에 대한 작업을 수행하기 전에 전기회로와 관련된 위험요소들을 확인하시고 사전에 사고를 방지할 수 있도록 표준 작업절차를 준수해 주시기 바랍니다.

해당 번역문을 찾기 위해 각 경고의 마지막 부분에 제공된 경고문 번호를 참조하십시오

#### BELANGRIJKE VEILIGHEIDSINSTRUCTIES

Dit waarschuwings symbool betekent gevaar. U verkeert in een situatie die lichamelijk letsel kan veroorzaken. Voordat u aan enige apparatuur gaat werken, dient u zich bewust te zijn van de bij een elektrische installatie betrokken risico's en dient u op de hoogte te zijn van de standaard procedures om ongelukken te voorkomen. Gebruik de nummers aan het eind van elke waarschuwing om deze te herleiden naar de desbetreffende locatie.

BEWAAR DEZE INSTRUCTIES

## Installation Instructions



### Warning!

Read the installation instructions before connecting the system to the power source.

設置手順書

システムを電源に接続する前に、設置手順書をお読み下さい。

警告

将此系统连接电源前，请先阅读安装说明。

警告

將系統與電源連接前，請先閱讀安裝說明。

Warnung

Vor dem Anschließen des Systems an die Stromquelle die Installationsanweisungen lesen.

¡Advertencia!

Lea las instrucciones de instalación antes de conectar el sistema a la red de alimentación.

Attention

Avant de brancher le système sur la source d'alimentation, consulter les directives d'installation.

יש לקרוא את הוראות התקנה לפני חיבור המערכת למקור מתח.

أقر إرشادات التركيب قبل توصيل النظام إلى مصدر للطاقة

주의!

시스템을 전원에 연결하기 전에 설치 안내를 읽어주십시오.

Waarschuwing

Raadpleeg de installatie-instructies voordat u het systeem op de voedingsbron aansluit.

## Circuit Breaker



### Warning!

This product relies on the building's installation for short-circuit (overcurrent) protection. Ensure that the protective device is rated not greater than: 250 V, 20 A.

サーキット・ブレーカー

この製品は、短絡(過電流)保護装置がある建物での設置を前提としています。

保護装置の定格が60V、20Aを超えないことを確認下さい。

### 警告

此产品的短路(过载电流)保护由建筑物的供电系统提供,确保短路保护设备的额定电流不大于600V,20A。

### 警告

此产品的短路(過載電流)保護由建築物的供電系統提供,確保短路保護設備的額定電流不大於60V,20A。

### Warnung

Dieses Produkt ist darauf angewiesen, dass im Gebäude ein Kurzschluss- bzw. Überstromschutz installiert ist. Stellen Sie sicher, dass der Nennwert der Schutzvorrichtung nicht mehr als: 60V, 20A beträgt.

### ¡Advertencia!

Este equipo utiliza el sistema de protección contra cortocircuitos (o sobrecorrientes) del edificio. Asegúrese de que el dispositivo de protección no sea superior a: 60V, 20A.

### Attention

Pour ce qui est de la protection contre les courts-circuits (surtension), ce produit dépend de l'installation électrique du local. Vérifiez que le courant nominal du dispositif de protection n'est pas supérieur à :60V, 20A.

מוצר זה מסתמך על הגנה המותקנת במבנים למניעת קצר חשמלי. יש לוודא כי המכשיר המגן מפני הקצר החשמלי הוא לא יותר מ-250 V, 20 A

هذا المنتج يعتمد على معدات الحماية من الدوائر القصيرة التي تم تثبيتها في المبنى

경고!

이 제품은 전원의 단락(과전류)방지에 대해서 전적으로 건물의 관련 설비에 의존합니다. 보호장치의 정격이 반드시 60V(볼트), 20A(암페어)를 초과하지 않도록 해야 합니다.

#### Waarschuwing

Dit product is afhankelijk van de kortsluitbeveiliging (overspanning) van uw elektrische installatie. Controleer of het beveiligde apparaat niet groter gedimensioneerd is dan 60V, 20A.

### Power Disconnection Warning



#### Warning!

The system must be disconnected from all sources of power and the power cord removed from the power supply module(s) before accessing the chassis interior to install or remove system components.

#### 電源切断の警告

システムコンポーネントの取り付けまたは取り外しのために、シャーシ内部にアクセスするには、

システムの電源はすべてのソースから切断され、電源コードは電源モジュールから取り外す必要があります。

#### 警告

在你打开机箱并安装或移除内部器件前，必须将系统完全断电，并移除电源线。

#### 警告

在您打開機殼安裝或移除內部元件前，必須將系統完全斷電，並移除電源線。

#### Warnung

Das System muss von allen Quellen der Energie und vom Netzanschlusskabel getrennt sein, das von den Spg.Versorgungsteilmodulen entfernt wird, bevor es auf den Chassisinnenraum zurückgreift, um Systemsbestandteile anzubringen oder zu entfernen.

¡Advertencia!

El sistema debe ser disconnected de todas las fuentes de energía y del cable eléctrico quitado de los módulos de fuente de alimentación antes de tener acceso el interior del chasis para instalar o para quitar componentes de sistema.

Attention

Le système doit être débranché de toutes les sources de puissance ainsi que de son cordon d'alimentation secteur avant d'accéder à l'intérieur du châssis pour installer ou enlever des composants de système.

**אזהרה!**

יש לנתק את המערכת מכל מקורות החשמל ויש להסיר את כבל החשמלי מהספק לפני גישה לחלק הפנימי של המארז לצורך התקנת או הסרת רכיבים.

يجب فصل النظام من جميع مصادر الطاقة وإزالة سلك الكهرباء من وحدة امداد الطاقة قبل الوصول إلى المناطق الداخلية للهيكल لتثبيت أو إزالة مكونات الجهاز

경고!

시스템에 부품들을 장착하거나 제거하기 위해서는 새시 내부에 접근하기 전에 반드시 전원 공급장치로부터 연결되어있는 모든 전원과 전기코드를 분리해주어야 합니다.

Waarschuwing

Voordat u toegang neemt tot het binnenwerk van de behuizing voor het installeren of verwijderen van systeem onderdelen, dient u alle spanningsbronnen en alle stroomkabels aangesloten op de voeding(en) van de behuizing te verwijderen

## Equipment Installation



### Warning!

Only trained and qualified personnel should be allowed to install, replace, or service this equipment.

### 機器の設置

トレーニングを受け認定された人だけがこの装置の設置、交換、またはサービスを許可されています。

### 警告

只有经过培训且具有资格的人员才能进行此设备的安装、更换和维修。

### 警告

只有經過受訓且具資格人員才可安裝、更換與維修此設備。

### Warnung

Das Installieren, Ersetzen oder Bedienen dieser Ausrüstung sollte nur geschultem, qualifiziertem Personal gestattet werden.

### ¡Advertencia!

Solamente el personal calificado debe instalar, reemplazar o utilizar este equipo.

### Attention

Il est vivement recommandé de confier l'installation, le remplacement et la maintenance de ces équipements à des personnels qualifiés et expérimentés.

### אזהרה!

צוות מוסמך בלבד רשאי להתקין, להחליף את הציוד או לתת שירות עבור הציוד.

يجب أن يسمح فقط للموظفين المؤهلين والمدربين لتثبيت واستبدال أو خدمة هذا الجهاز

### 경고!

훈련을 받고 공인된 기술자만이 이 장비의 설치, 교체 또는 서비스를 수행할 수 있습니다.



## Waarschuwing

Deze apparatuur mag alleen worden geïnstalleerd, vervangen of hersteld door geschoold en gekwalificeerd personeel.

## Restricted Area



### Warning!

This unit is intended for installation in restricted access areas. A restricted access area can be accessed only through the use of a special tool, lock and key, or other means of security. (This warning does not apply to workstations).

## アクセス制限区域

このユニットは、アクセス制限区域に設置されることを想定しています。

アクセス制限区域は、特別なツール、鍵と錠前、その他のセキュリティの手段を用いてのみ出入りが可能です。

## 警告

此部件应安装在限制进出的场所，限制进出的场所指只能通过使用特殊工具、锁和钥匙或其它安全手段进出的场所。

## 警告

此裝置僅限安裝於進出管制區域，進出管制區域係指僅能以特殊工具、鎖頭及鑰匙或其他安全方式才能進入的區域。

## Warnung

Diese Einheit ist zur Installation in Bereichen mit beschränktem Zutritt vorgesehen. Der Zutritt zu derartigen Bereichen ist nur mit einem Spezialwerkzeug, Schloss und Schlüssel oder einer sonstigen Sicherheitsvorkehrung möglich.

## ¡Advertencia!

Esta unidad ha sido diseñada para instalación en áreas de acceso restringido. Sólo puede obtenerse acceso a una de estas áreas mediante la utilización de una herramienta especial, cerradura con llave u otro medio de seguridad.

## Attention

Cet appareil doit être installée dans des zones d'accès réservés. L'accès à une zone d'accès réservé n'est possible qu'en utilisant un outil spécial, un mécanisme de verrouillage et une clé, ou tout autre moyen de sécurité.

## אזור עם גישה מוגבלת

### אזהרה!

יש להתקין את היחידה באזורים שיש בהם הגבלת גישה. הגישה ניתנת בעזרת כלי אבטחה בלבד (מפתח, מנעול וכד').

تم تخصيص هذه الوحدة لت تركيبها في مناطق محظورة . يمكن الوصول إلى منطقة محظورة فقط من خلال استخدام أداة خاصة، قفل ومفتاح أو أي وسيلة أخرى للالأمان

경고!

이 장치는 접근이 제한된 구역에 설치하도록 되어 있습니다. 특수도구, 잠금 장치 및 키, 또는 기타 보안 수단을 통해서만 접근 제한 구역에 들어갈 수 있습니다.

Waarschuwing

Dit apparaat is bedoeld voor installatie in gebieden met een beperkte toegang. Toegang tot dergelijke gebieden kunnen alleen verkregen worden door gebruik te maken van speciaal gereedschap, slot en sleutel of andere veiligheidsmaatregelen.

## Battery Handling



### Warning!

There is the danger of explosion if the battery is replaced incorrectly. Replace the battery only with the same or equivalent type recommended by the manufacturer. Dispose of used batteries according to the manufacturer's instructions

電池の取り扱い

電池交換が正しく行われなかった場合、破裂の危険性があります。交換する電池はメーカーが推奨する型、または同等のものを使用下さい。使用済電池は製造元の指示に従って処分して下さい。

警告

電池更換不當會有爆炸危險。請只使用同類電池或製造商推薦的功能相當的電池更換原有電池。請按製造商的說明處理廢舊電池。

警告

電池更換不當會有爆炸危險。請使用製造商建議之相同或功能相當的電池更換原有電池。請按照製造商的說明指示處理廢棄舊電池。

### Warnung

Bei Einsetzen einer falschen Batterie besteht Explosionsgefahr. Ersetzen Sie die Batterie nur durch den gleichen oder vom Hersteller empfohlenen Batterietyp. Entsorgen Sie die benutzten Batterien nach den Anweisungen des Herstellers.

### Attention

Danger d'explosion si la pile n'est pas remplacée correctement. Ne la remplacer que par une pile de type semblable ou équivalent, recommandée par le fabricant. Jeter les piles usagées conformément aux instructions du fabricant.

### ¡Advertencia!

Existe peligro de explosión si la batería se reemplaza de manera incorrecta. Reemplazar la batería exclusivamente con el mismo tipo o el equivalente recomendado por el fabricante. Desechar las baterías gastadas según las instrucciones del fabricante.

### אזהרה!

קיימת סכנת פיצוץ של הסוללה במידה והוחלפה בדרך לא תקינה. יש להחליף את הסוללה בסוג התואם מחברת יצרן מומלצת.

סילוק הסוללות המשומשות יש לבצע לפי הוראות היצרן.

هناك خطر من انفجار في حالة استبدال البطارية بطريقة غير صحيحة فعليك استبدال البطارية فقط بنفس النوع أو ما يعادلها كما أوصت به الشركة المصنعة تخلص من البطاريات المستعملة وفقا لتعليمات الشركة الصانعة

### 경고!

배터리가 올바르게 교체되지 않으면 폭발의 위험이 있습니다. 기존 배터리와 동일하거나 제조사에서 권장하는 동등한 종류의 배터리로만 교체해야 합니다. 제조사의 안내에 따라 사용된 배터리를 처리하여 주십시오.

### Waarschuwing

Er is ontploffingsgevaar indien de batterij verkeerd vervangen wordt. Vervang de batterij slechts met hetzelfde of een equivalent type die door de fabrikant aanbevolen wordt. Gebruikte batterijen dienen overeenkomstig fabrieksvoorschriften afgevoerd te worden.

## Redundant Power Supplies



### Warning!

This unit might have more than one power supply connection. All connections must be removed to de-energize the unit.

#### 冗長電源装置

このユニットは複数の電源装置が接続されている場合があります。  
ユニットの電源を切るためには、すべての接続を取り外さなければなりません。

#### 警告

此部件连接的电源可能不止一个，必须将所有电源断开才能停止给该部件供电。

#### 警告

此装置连接的電源可能不只一個，必須切斷所有電源才能停止對該裝置的供電。

#### Warnung

Dieses Gerät kann mehr als eine Stromzufuhr haben. Um sicherzustellen, dass der Einheit kein Strom zugeführt wird, müssen alle Verbindungen entfernt werden.

#### ¡Advertencia!

Puede que esta unidad tenga más de una conexión para fuentes de alimentación. Para cortar por completo el suministro de energía, deben desconectarse todas las conexiones.

#### Attention

Cette unité peut avoir plus d'une connexion d'alimentation. Pour supprimer toute tension et tout courant électrique de l'unité, toutes les connexions d'alimentation doivent être débranchées.

**אם קיים יותר מספק אחד**

**אזהרה!**

ליחידה יש יותר מחיבור אחד של ספק. יש להסיר את כל החיבורים על מנת לרוקן את היחידה.

قد يكون لهذا الجهاز عدة اتصالات بوحدات امداد الطاقة.  
يجب إزالة كافة الاتصالات لعزل الوحدة عن الكهرباء

경고!

이 장치에는 한 개 이상의 전원 공급 단자가 연결되어 있을 수 있습니다. 이 장치에 전원을 차단하기 위해서는 모든 연결 단자를 제거해야만 합니다.

Waarschuwing

Deze eenheid kan meer dan één stroomtoevoeraansluiting bevatten. Alle aansluitingen dienen verwijderd te worden om het apparaat stroomloos te maken.

### Backplane Voltage



**Warning!**

Hazardous voltage or energy is present on the backplane when the system is operating. Use caution when servicing.

バックプレーンの電圧

システムの稼働中は危険な電圧または電力が、バックプレーン上にかかっています。

修理する際にはご注意ください。

警告

当系统正在进行时，背板上有很危险的电压或能量，进行维修时务必小心。

警告

當系統正在進行時，背板上危險的電壓或能量，進行維修時務必小心。

Warnung

Wenn das System in Betrieb ist, treten auf der Rückwandplatine gefährliche Spannungen oder Energien auf. Vorsicht bei der Wartung.

¡Advertencia!

Cuando el sistema está en funcionamiento, el voltaje del plano trasero es peligroso. Tenga cuidado cuando lo revise.

Attention

Lorsque le système est en fonctionnement, des tensions électriques circulent sur le fond de panier. Prendre des précautions lors de la maintenance.

## מתח בפנל האחורי

אזהרה!  
קיימת סכנת מתח בפנל האחורי בזמן תפעול המערכת. יש להיזהר במהלך  
העבודה.

هناك خطر من التيار الكهربائي أو الطاقة الموجودة على اللوحة  
عندما يكون النظام يعمل كن حذرا عند خدمة هذا الجهاز

경고!

시스템이 동작 중일 때 후면판 (Backplane)에는 위험한 전압이나 에너지가 발생  
합니다. 서비스 작업 시 주의하십시오.

Waarschuwing

Een gevaarlijke spanning of energie is aanwezig op de backplane wanneer het  
systeem in gebruik is. Voorzichtigheid is geboden tijdens het onderhoud.

## Comply with Local and National Electrical Codes



### Warning!

Installation of the equipment must comply with local and national electrical codes.

地方および国の電気規格に準拠

機器の取り付けはその地方および国の電気規格に準拠する必要があります。

警告

设备安装必须符合本地与本国电气法规。

警告

設備安裝必須符合本地與本國電氣法規。

Warnung

Die Installation der Geräte muss den Sicherheitsstandards entsprechen.

¡Advertencia!

La instalación del equipo debe cumplir con las normas de electricidad locales y  
nacionales.

Attention

L'équipement doit être installé conformément aux normes électriques nationales et locales.

**תיאום חוקי החשמל הארצי**

**אזהרה!**

התקנת הציוד חייבת להיות תואמת לחוקי החשמל המקומיים והארציים.

تركيب المعدات الكهربائية يجب أن يمتثل للقوانين المحلية والوطنية المتعلقة بالكهرباء

경고!

현 지역 및 국가의 전기 규정에 따라 장비를 설치해야 합니다.

Waarschuwing

Bij installatie van de apparatuur moet worden voldaan aan de lokale en nationale elektriciteitsvoorschriften.

**Product Disposal**



**Warning!**

Ultimate disposal of this product should be handled according to all national laws and regulations.

**製品の廃棄**

この製品を廃棄処分する場合、国の関係する全ての法律・条例に従い処理する必要があります。

**警告**

本产品的废弃处理应根据所有国家的法律和规章进行。

**警告**

本產品的廢棄處理應根據所有國家的法律和規章進行。

**Warnung**

Die Entsorgung dieses Produkts sollte gemäß allen Bestimmungen und Gesetzen des Landes erfolgen.

¡Advertencia!

Al deshacerse por completo de este producto debe seguir todas las leyes y reglamentos nacionales.

Attention

La mise au rebut ou le recyclage de ce produit sont généralement soumis à des lois et/ou directives de respect de l'environnement. Renseignez-vous auprès de l'organisme compétent.

## סילוק המוצר

אזהרה!

סילוק סופי של מוצר זה חייב להיות בהתאם להנחיות וחוקי המדינה.

عند التخلص النهائي من هذا المنتج ينبغي التعامل معه وفقا لجميع القوانين واللوائح الوطنية

경고!

이 제품은 해당 국가의 관련 법규 및 규정에 따라 폐기되어야 합니다.

Waarschuwing

De uiteindelijke verwijdering van dit product dient te geschieden in overeenstemming met alle nationale wetten en reglementen.

## Hot Swap Fan Warning



### Warning!

The fans might still be turning when you remove the fan assembly from the chassis. Keep fingers, screwdrivers, and other objects away from the openings in the fan assembly's housing.

ファン・ホットスワップの警告

シャーシから冷却ファン装置を取り外した際、ファンがまだ回転している可能性があります。ファンの開口部に、指、ドライバー、およびその他のものを近づけないで下さい。

警告

当您从机架移除风扇装置，风扇可能仍在转动。小心不要将手指、螺丝起子和其他物品太靠近风扇



**警告**

當您從機架移除風扇裝置，風扇可能仍在轉動。小心不要將手指、螺絲起子和其他物品太靠近風扇。

**Warnung**

Die Lüfter drehen sich u. U. noch, wenn die Lüfterbaugruppe aus dem Chassis genommen wird. Halten Sie Finger, Schraubendreher und andere Gegenstände von den Öffnungen des Lüftergehäuses entfernt.

**¡Advertencia!**

Los ventiladores podran dar vuelta cuando usted quite el montaje del ventilador del chasis. Mantenga los dedos, los destornilladores y todos los objetos lejos de las aberturas del ventilador

**Attention**

Il est possible que les ventilateurs soient toujours en rotation lorsque vous retirez le bloc ventilateur du châssis. Prenez garde à ce que doigts, tournevis et autres objets soient éloignés du logement du bloc ventilateur.

**אזהרה!**

כאשר מסירים את חלקי המאוורר מהמארז, יתכן והמאווררים עדיין עובדים. יש להרחיק למרחק בטוח את האצבעות וכלי עבודה שונים מהפתחים בתוך המאוורר

من الممكن أن تزال المراوح لا تزال تدور عند إزالة كتلة المروحة من الهيكل يجب إبقاء الأصابع ومفكات البراغي وغيرها من الأشياء بعيدا عن الفتحات في كتلة المروحة.

**경고!**

새시로부터 팬 조립품을 제거할 때 팬은 여전히 회전하고 있을 수 있습니다. 팬 조립품 외관의 열려있는 부분들로부터 손가락 및 스크류드라이버, 다른 물체들이 가까이 하지 않도록 배치해 주십시오.

**Waarschuwing**

Het is mogelijk dat de ventilator nog draait tijdens het verwijderen van het ventilatorsamenstel uit het chassis. Houd uw vingers, schroevendraaiers en eventuele andere voorwerpen uit de buurt van de openingen in de ventilatorbehuizing.

## DC Power Supply



### Warning!

When stranded wiring is required, use approved wiring terminations, such as closedloop or spade-type with upturned lugs. These terminations should be the appropriate size for the wires and should clamp both the insulation and conductor.

### 警告

より線が必要な場合、承認済みのケーブル終端(上向きの端子を備えたクローズループ型またはU字型の終端など)を使用してください。使用するワイヤーに適したサイズで、絶縁体および導体が両方ともクランプされている終端でなければなりません。

### 警告

需要多股佈線時、請使用經核准的佈線終端，例如閉環或鏟型接線片。這些終端的大小應適合線路，並且可以同時夾住絕緣體和導體。

### 警告

需要使用绞线连接时，请使用经认可的连接端子，如闭环端子或具有接线柱的铲形端子。这些端子的大小应与线缆相吻合，并且可以将绝缘部分和导体夹紧固定。

### Warnung

Wenn Litzenverdrahtung erforderlich ist, sind zugelassene Verdrahtungsabschlüsse, z.B. für einen geschlossenen Regelkreis oder gabelförmig, mit nach oben gerichteten Kabelschuhen zu verwenden. Diese Abschlüsse sollten die angemessene Größe für die Drähte haben und sowohl die Isolierung als auch den Leiter festklemmen.

### ¡Advertencia!

Quando se necesite hilo trenzado, utilizar terminales para cables homologados, tales como las de tipo "bucle cerrado" o "espada", con las lengüetas de conexión vueltas hacia arriba. Estos terminales deberán ser del tamaño apropiado para los cables que se utilicen, y tendrán que sujetar tanto el aislante como el conductor.

## Attention

Quand des fils torsadés sont nécessaires, utiliser des douilles terminales homologuées telles que celles à circuit fermé ou du type à plage ouverte avec cosses rebroussées. Ces douilles terminales doivent être de la taille qui convient aux fils et doivent être refermées sur la gaine isolante et sur le conducteur.

## תקנון הצהרות אזהרה

הצהרות הבאות הן אזהרות על פי תקני התעשייה, על מנת להזהיר את המשתמש מפני חבלה פיזית אפשרית. במידה ויש שאלות או היתקלות בבעיה כלשהי, יש ליצור קשר עם מחלקת תמיכה טכנית של סופרמיקרו. טכנאים מוסמכים בלבד רשאים להתקין או להגדיר את הרכיבים.

יש לקרוא את הנספח במלואו לפני התקנת או הגדרת הרכיבים במארזי סופרמיקרו.

## تحذير

كإل سأل ما دختس او ، لبس ل مهب تعطقت ني ذل كإل سأل ا بولطم نو كي امدن ع  
عون ل ة ي ق ي ق ح ل ا ه ي ا م س أ ب ا ع ي ش أ ل ا و أ ق ق ل غ م ق ق ل ح ل ش م ، ا ه ي ل ع ق ق ف ا و م ل ا ء ا ه ن  
كإل سأل ل بس ا ن م ل ا م ح ح ل ا نو كي ت ا ء ا ه ن إ ل ا ه ذ ل ي غ ب ن ي و . ق ب و ل ق م ت ا و ر ع ل ا ع م  
ل ص و م و ل ز ع ل ا ن م ل ك ح ب ك ب ج ي و

## 주의!

꼬인 배선이 요구 될 때에는 폐회로나 돌출부가 위로 튀어 나온 Spade 형태의 승인된 배선 터미네이션들을 사용하세요.

이 터미네이션들은 배선들을 위해 적절한 크기여야 하고, 절연체와 도체 모두를 고정시킬 수 있어야 합니다.

## Waarschuwing

Wanneer geslagen bedrading vereist is, dient u bedrading te gebruiken die voorzien is van goedgekeurde aansluitingspunten, zoals het gesloten-lus type of het grijperschop type waarbij de aansluitpunten omhoog wijzen. Deze aansluitpunten dienen de juiste maat voor de draden te hebben en dienen zowel de isolatie als de geleider vast te klemmen.



주의!

다음 절차를 수행하기 전에, 전원이 DC 회로로부터 제거되었는지를 확인해 주십시오.

Waarschuwing

Wanneer geslagen bedrading vereist is, dient u bedrading te gebruiken die voorzien is van goedgekeurde aansluitingspunten, zoals het gesloten-lus type of het grijperschop type waarbij de aansluitpunten omhoog wijzen. Deze aansluitpunten dienen de juiste maat voor de draden te hebben en dienen zowel de isolatie als de geleider vast te klemmen.

### **Hazardous Voltage or Energy Present on DC Power Terminals**



**Warning!**

Hazardous voltage or energy may be present on DC power terminals. Always replace cover when terminals are not in service. Be sure uninsulated conductors are not accessible when cover is in place.

警告

直接電力端子に危険な電圧やエネルギーが発生している可能性があります。使用していない端子には常にカバーをつけてください。カバーがついているときは非絶縁形コンダクターに接触していないことを確認してください。

警告

直流電源終端可能產生危險的電壓或能量。終端不使用時，請務必蓋上機蓋。當蓋上機蓋，確認不絕緣導體無法使用。

警告

直流电源终端可能会产生危险的电压或能量。终端不使用时，请务必盖上机盖。机盖盖上后，请确保导体未绝缘部分无法使用。

Warnung

In mit Gleichstrom betriebenen Terminals kann es zu gefährlicher Spannung kommen. Die Terminals müssen abgedeckt werden, wenn sie nicht in Betrieb sind. Stellen Sie bei Benutzung der Abdeckung sicher, dass alle nicht isolierten, stromführenden Kabel abgedeckt sind.

¡Advertencia!

Puede haber energía o voltaje peligrosos en los terminales eléctricos de CC. Reemplace siempre la cubierta cuando no estén utilizándose los terminales. Asegúrese de que no haya acceso a conductores descubiertos cuando la cubierta esté colocada.

Attention

Le voltage ou l'énergie électrique des terminaux à courant continu peuvent être dangereux. Veuillez à toujours replacer le couvercle lors les terminaux ne sont pas en service. Assurez-vous que les conducteurs non isolés ne sont pas accessibles lorsque le couvercle est en place.

**אזהרה!**

מקור מתח מסוכן עלול להיות נוכח על הקטבים של זרם ה-DC. החלף תמיד את המכסה כאשר הקטבים לא בשימוש. ודא כי המוליכים הלא מבודדים אינם נגישים כאשר המכסה נמצא במקומו.

**تحذير**

لادبتسا. ؤمصاعلا ؤق اظلا تااطحم ىل ع ؤدوجوم نوكت ؤق اظلا و ا ؤرطخل ا دهجل ا دق ريغ تالصولا هيف لكش ال امم. ؤمدخل ا يف تسيل تااطحمل ا مدن ع امئاد ااطغ هنالكم يف ااطغلا ا مدن ع اهيل ا لوصول ا نلكمي ال لوزعم

주의!

DC전원 단자들에 위험한 전압이나 에너지가 발생할 수 있습니다.

단말기들을 운영하지 않을 때에는 덮개로 다시 덮어 놓아 주십시오. 덮개가 제자리에 있어야만 절연되지 않은 도체들의 접근을 막을 수 있습니다.

Waarschuwing

Op DC-aansluitingspunten kunnen zich gevaarlijke voltages of energieën voordoen. Plaats altijd de afsluiting wanneer de aansluitingspunten niet worden gebruikt. Zorg ervoor dat blootliggende contactpunten niet toegankelijk zijn wanneer de afsluiting is geplaatst.

## Chapter 3

# Chassis Components

### 3-1 Overview

This chapter describes the most common components included with your chassis. Some components listed may not be included or compatible with your particular chassis model. For more information, see the installation instructions detailed later in this manual. This chassis includes three or four fans (with two or three optional fans if necessary) and one or two power supplies. For the latest shipping lists, visit our web site at: [www.supermicro.com](http://www.supermicro.com).

### 3-2 Components

#### Drives

The SC514-441 chassis supports one fixed 3.5" hard disk drive or two fixed 2.5" drives (with optional bracket). The SC514-R400C and SC514-R400W support two fixed 2.5" drives.

#### Fans

The chassis includes three or four heavy-duty fans with open slots for two or three additional fans if required. System fans for the SC514 chassis are powered from the serverboard. These fans are 1U high and are powered by 4-pin connectors.

#### Mounting Rails

The SC514 can be placed in a rack for secure storage and use. To set up your rack, follow the step-by-step instructions included in this manual.

#### Power Supply

Each SC514 chassis includes a high-efficiency power supply rated at 400 or 440/480 Watts. In the unlikely event your power supply fails, replacement is simple and may be done without tools. The SC514-R400C and SC514-R400W includes dual redundant power supplied which may be replaced without powering down the server.

### **Air Shroud (Optional)**

Air shrouds are shields, usually plastic, that channel air directly to where it is needed. Always use the air shroud included with your chassis.

### **3-3 Where to get Replacement Components**

Although not frequently, you may need replacement parts for your system. To ensure the highest level of professional service and technical support, we strongly recommend purchasing exclusively from our Supermicro Authorized Distributors/System Integrators/Resellers. A list of Supermicro Authorized Distributors/System Integrators/Reseller can be found at: <http://www.supermicro.com>. Click the Where to Buy link.



# Chapter 4

## System Interface

### 4-1 Overview

There are several LEDs on the control panel to monitor the overall status of the system as well as the activity and health of specific components. Power is controlled by two push-buttons on the control panel: a reset button and an on/off switch. This chapter covers these features, and explains the meanings of the LED indicators and the appropriate responses you may need to take.

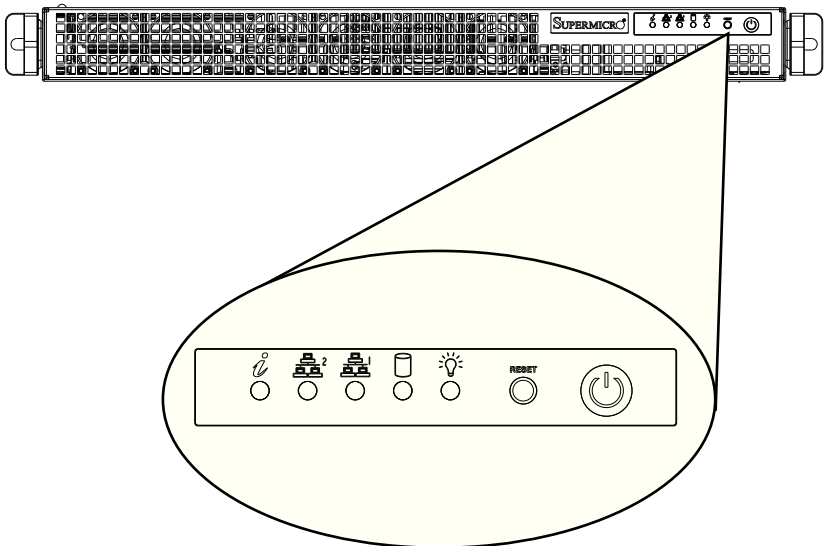

Figure 4-1. Chassis User Interface

## 4-2 Control Panel Buttons

There are two push-buttons located on the front of the chassis. These are (in order from left to right) a reset button and a power on/off button.



**Reset:** The reset button is used to reboot the system.



**Power:** The main power switch is used to apply or remove power from the power supply to the server system. Turning off system power with this button removes the main power but keeps standby power supplied to the system. Therefore, you must unplug system before servicing.

## 4-3 Control Panel LEDs

The control panel located on the front of the SC514 chassis has five LEDs. These LEDs provide you with critical information related to different parts of the system. This section explains what each LED indicates when illuminated and any corrective action you may need to take.



Informational LED	
Status	Description
Solid red	An overheat condition has occurred. (This may be caused by cable congestion).
Blinking red (1Hz)	Fan failure, check for an inoperative fan.
Blinking red (0.25Hz)	Power failure, check for a non-operational power supply.
Solid blue	Local UID has been activated. Use this function to locate the server in a rack mount environment.
Blinking blue (300 msec)	Remote UID is on. Use this function to identify the server from a remote location.

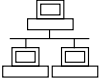

**NIC2:** Indicates network activity on GLAN2 when flashing.



**NIC1:** Indicates network activity on GLAN1 when flashing.



**HDD:** Indicates IDE channel activity. SAS/SATA drive and/or DVD-ROM drive activity when flashing.



**Power:** Indicates power is being supplied to the system's power supply units. This LED should normally be illuminated when the system is operating.

## 4-4 Power Supply LEDs

On the rear of the power supply module, an LED displays the status.

- **Solid Green:** When illuminated, indicates that the power supply is on.
- **Solid Amber:** When illuminated, indicates the power supply is plugged in and turned off, or the system is off but in an abnormal state.
- **Blinking Amber:** When blinking, this system power supply temperature has reached 63°C. The system will automatically power-down when the power supply temperature reaches 70°C and restarts when the power supply temperature goes below 60°C.

## Chapter 5

# Chassis Setup and Maintenance

### 5-1 Overview

This chapter covers the steps required to install components and perform maintenance on the chassis. The only tool required is a Phillips screwdriver, and under certain circumstances, a hex wrench..

Review the warnings and precautions listed in the manual before setting up or servicing this chassis. These include information in Chapter 2: System Safety and the warning/precautions listed in the setup instructions.

### 5-2 Removing Power from the System

Before performing most setup or maintenance tasks, use the following procedure to ensure that power has been removed from the system.

1. Use the operating system to power down the system <or node>, following the on-screen prompts.
2. After the system has completely shut-down, carefully grasp the head of the power cord and gently pull it out of the back of the power supply. If your system has dual power supplies, remove the cords from both power supplies.
3. Disconnect the cord from the power strip or wall outlet.

## 5-3 Removing the Chassis Cover

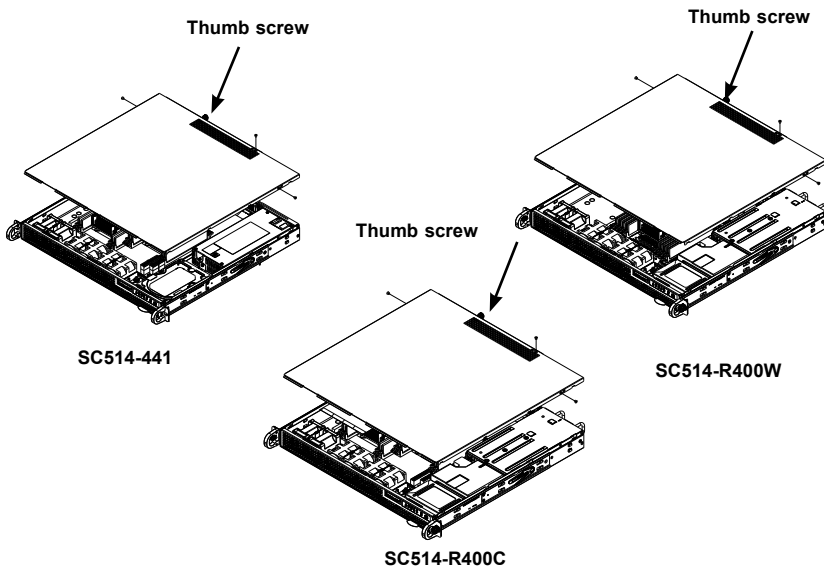

Figure 5-1. Removing the Chassis Cover

### *Removing the Chassis Cover the Chassis Cover*

1. Power down the system as described in section 5-2.
2. Remove the three screws and the one thumbscrew securing the top cover to the chassis.
3. Slide the cover back toward the rear of the chassis.
4. Lift the cover upwards and off of the chassis.

**Caution:** Except for short periods of time, do not operate the server without the cover in place. The chassis cover must be in place to allow proper airflow and prevent overheating.

## 5-4 Installing Hard Drives

The SC514 supports one or two fixed hard disk drives, depending on your server model. Only SAS or SATA enterprise level hard drives are recommended. The hard drives in your chassis may look slightly different than the ones shown in this manual.

### SC514-441 Model

This model supports one 3.5" drive or two 2.5" drives with an optional bracket.

#### *Installing a 3.5" Hard Disk Drive*

The drive can be mounted directly on the chassis (Figure 5-2), or it can be mounted first on an optional HDD tray (Figure 5-3) and attached to the chassis with one thumb screw. (similar to Figure 5-6)

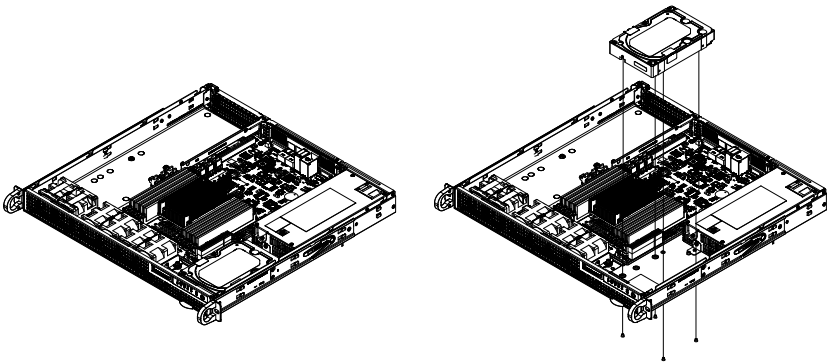

Figure 5-2. Model -441, Securing Hard Drive to the Chassis

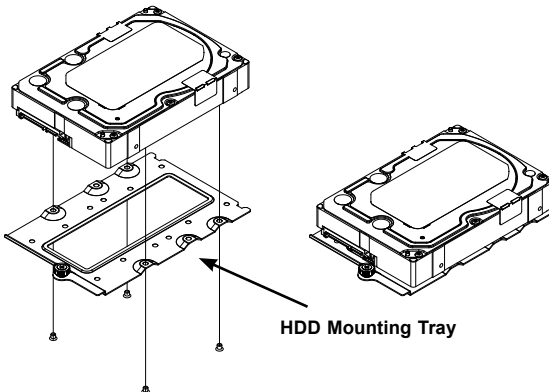
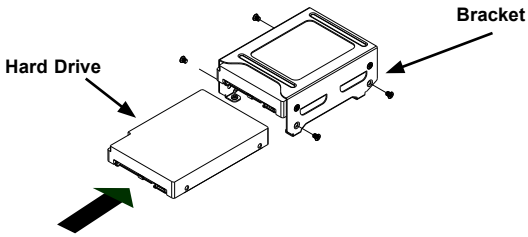

Figure 5-3. Model -441, Securing Hard Drive to the Tray



**Figure 5-4. Installing 2.5" Hard Drives into the Bracket**

***Installing 2.5" Hard Disk Drives***

1. Obtain the optional bracket and secure the drive(s) to the bracket. (Figure 5-4)
2. Secure the bracket to the optional HDD mounting tray. (Figure 5-5)

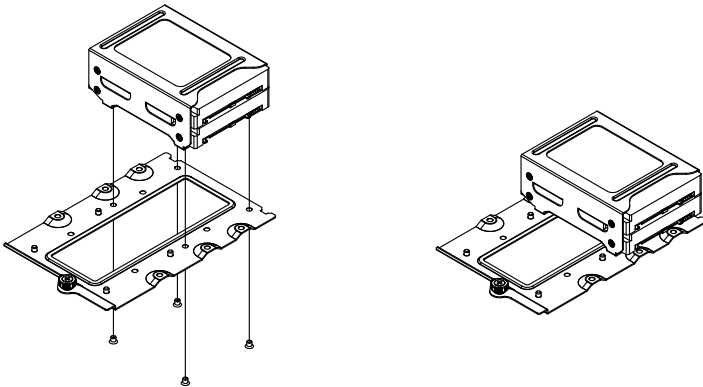

**Figure 5-5. Securing the Bracket to the HDD Tray**



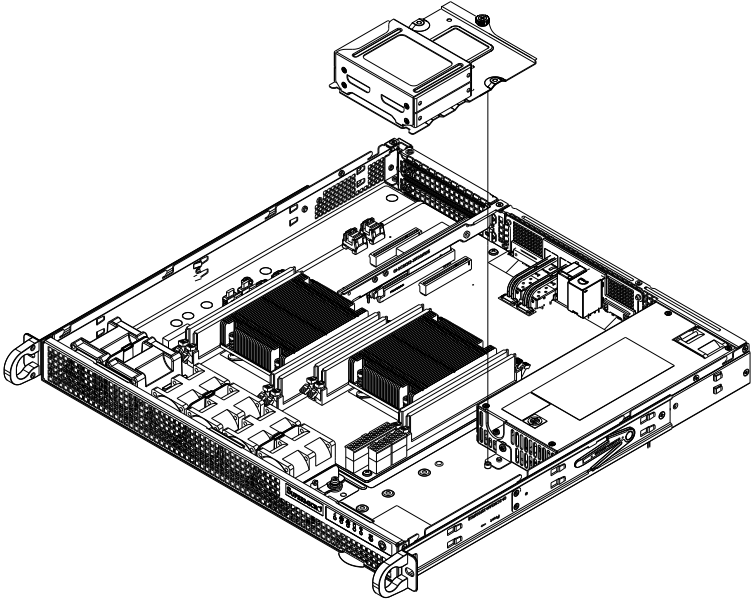

**Figure 5-6. Model -441, Securing the HDD Tray chassis Floor**

3. Secure the HDD tray to the chassis floor.
4. Connect HDD cabling.

## SC514-R400C and SC514-R400W Models

These models support two 2.5" drives with a bracket.

### *Installing Hard Disk Drives*

1. Obtain the drive bracket and secure the drive(s) to the bracket. (Figure5-4)
2. Secure the bracket to the chassis floor.

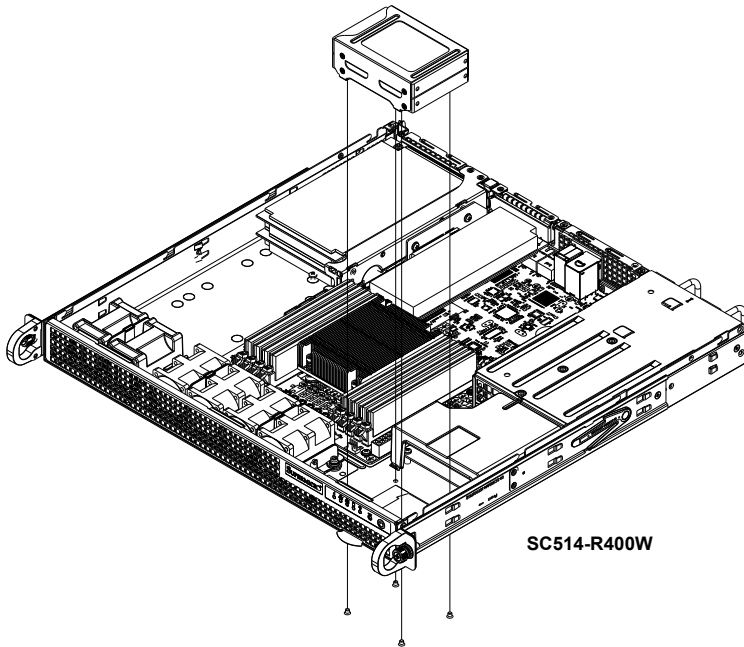

**Figure 5-7. Securing the Bracket to the Chassis**

## 5-5 Installing the Motherboard

### Installing the I/O Shield

The I/O shield holds the motherboard ports in place. Install the I/O shield before installing the motherboard. If the motherboard you purchased did not include a standard I/O shield, contact the motherboard vendor for a compatible shield.

#### *Installing the I/O Shield*

1. Review the documentation that came with your motherboard. Become familiar with component placement, requirements, and precautions.
2. Power down the system as described in section 5-2. Open the chassis cover as described in Section 5-3.
3. With the illustrations facing outward, place the shield into the space provided at the rear of the chassis as illustrated below.

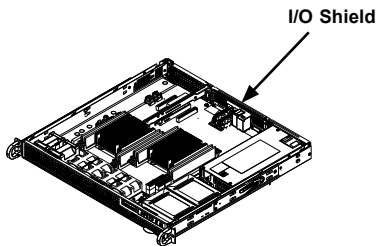

**Figure 5-8. Installing the I/O Shield**

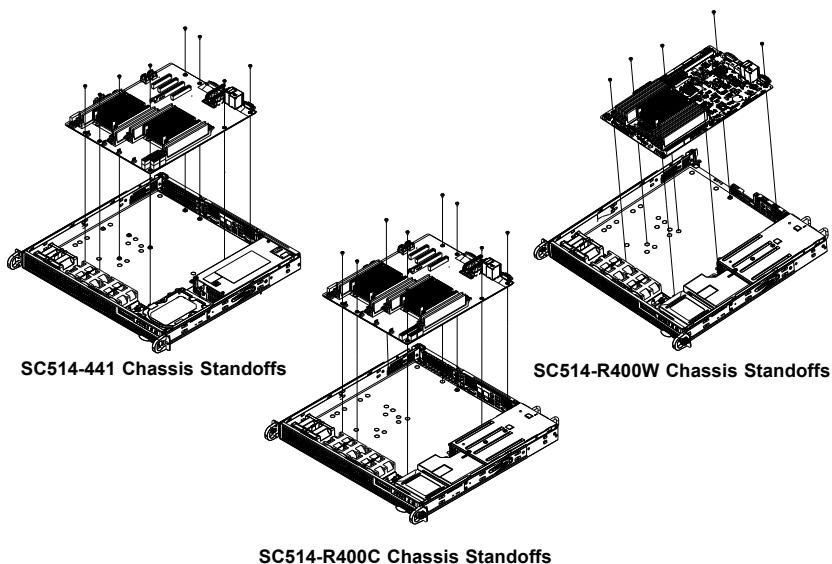

**Figure 5-9. Chassis Standoffs**

### **Permanent and Optional Standoffs**

Standoffs prevent short circuits by securing space between the motherboard and the chassis surface. The SC514 chassis includes permanent standoffs in locations used by most motherboards. These standoffs accept the rounded Phillips head screws included in the SC514 accessories packaging.

Some motherboards require additional screws for heatsinks, general components and/or non-standard methods to secure them. Optional standoffs are included for these motherboards. To use an optional standoff, you must place the hexagonal screw through the bottom the chassis and secure the screw with the hexagon nut (rounded side up). Compare the mounting holes in the motherboard to those in the chassis and add or remove standoffs as needed.

## Motherboard Installation

### *Installing the Motherboard*

1. Review the documentation that came with your motherboard. Become familiar with component placement, requirements, precautions, and cable connections.
2. Power down the system as described in section 5-2. Open the chassis cover as described in Section 5-3.
3. As required by your motherboard, install standoffs in any areas that do not have a permanent standoff. To do this:
  - a. Place a hexagonal standoff screw through the bottom the chassis.
  - b. Secure the screw with the hexagon nut (rounded side up).
4. Lay the motherboard on the chassis aligning the permanent and optional standoffs
5. Secure the motherboard to the chassis using the rounded, Phillips head screws. Do not exceed eight inch-pounds of torque when tightening the screws.
6. Secure the CPU(s), heatsinks, and other components to the motherboard as described in the motherboard documentation.
7. Connect the cables between the motherboard, backplane, chassis, front panel, and power supply, as needed. Also, the fans may be temporarily removed to allow access to the backplane ports.
8. Replace the chassis cover, plug the power cords into the rear of the power supplies and power up the system.

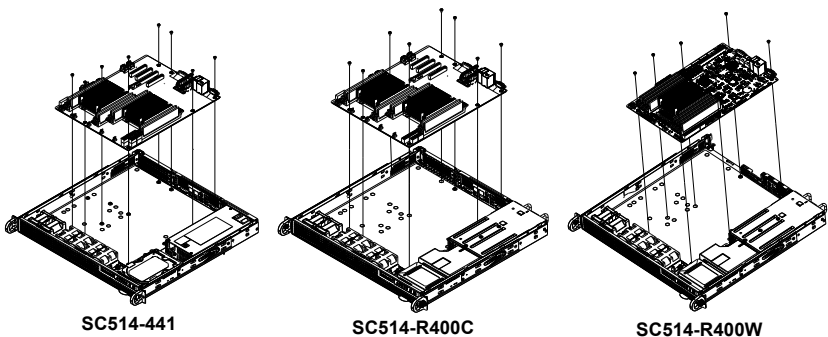
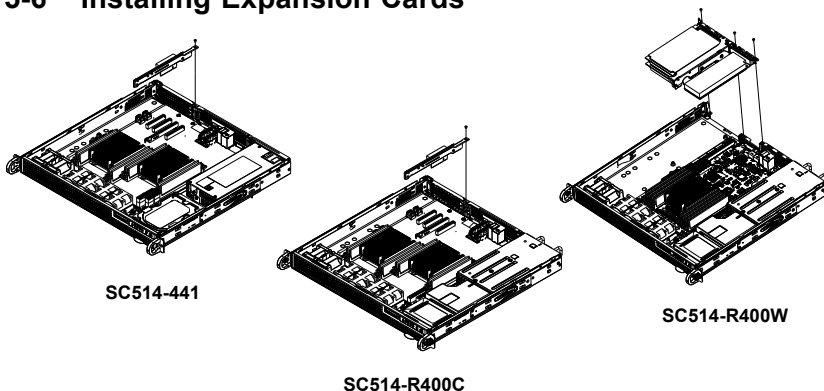

Figure 5-10. Installing the Motherboard

## 5-6 Installing Expansion Cards



**Figure 5-11. Expansion Card, Riser Card, Bracket and PCI Slot Cover**

### *Installing an Expansion Card*

1. Confirm that you have the correct riser card for your chassis model and the expansion card includes a standard bracket.
2. Power down the system as described in section 5-2 and open the chassis cover.
3. Remove the riser card bracket from the chassis.
4. Attach the riser card to the riser card bracket with screws.
5. Insert the expansion card(s) into the riser card slot(s).
6. Insert the riser card into the serverboard expansion slots while aligning the expansion card bracket with the openings in the rear of the chassis.
7. Secure the riser card bracket to the chassis and the expansion card bracket to the rear of the chassis.
8. Replace the chassis cover and power up the system.

## 5-7 Checking the Airflow

### *Checking the Server's Airflow*

- Make sure there are no objects to obstruct airflow in and out of the server.
- Do not operate the server without drives or drive carriers in the drive bays. Use only recommended server parts.
- Make sure no wires or foreign objects obstruct airflow through the chassis. Pull all excess cabling out of the airflow path or use shorter cables.

The control panel LEDs inform you of system status. See “Chapter 4: System Interface” for details on the LEDs and the control panel buttons.

### **Installation Complete**

In most cases, the chassis power supply and fans are pre-installed. If you need to install fans or a power supply, continue to the following sections of this chapter. If the chassis will be installed into a rack, skip to the next chapter for rack installation instructions.

## 5-8 System Fans

The SC514 chassis includes four heavy-duty fans and sockets for two optional fans to provide cooling.

### *Replacing a System Fan*

1. If necessary, open the chassis cover as described in Section 5-3 while the power is running to determine which fan requires changing. (Never run the server for an extended period of time with the chassis open.)
2. Power down the system as described in section 5-2.
3. Remove the failed fan's cable from the connector on the motherboard.
4. Lift the fan housing and the two fans inside it up and out of the chassis. Gently pull upward to remove a failed fan from the housing.
5. Place the new fan into the vacant space in the housing. Make sure that the arrows on the sides of the fan (indicating air direction) point in the same direction as the arrows on the other fans.
6. Plug the fan's cable into the connector on the motherboard.
7. Place the fan housing into the chassis and secure it with the screws previously set aside.
8. Plug the power cord into the rear of the power supply, power up the system and check that the fan is working properly before replacing the top cover.

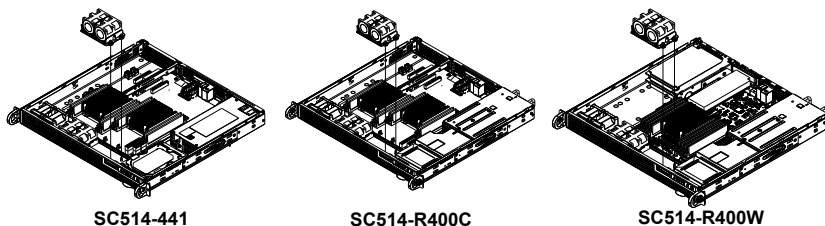

**Figure 5-12. Installing System Fans**



## 5-9 Power Supply

The SC514 chassis has one 440W/480W or two 400W power supplies. The power supplies are auto-switching capable. This enables it to automatically sense and operate at a 100v to 240v input voltage. If your system has one fixed power supply it will be necessary to shut down the system in order to change the power supply. If your system includes a redundant power supply, it is hot-swappable and can be changed without powering down the system.

### ***Changing a Fixed Power Supply (SC514-441)***

1. Power down the system as described in section 5-2. Lay the chassis on a flat, stable surface and remove the chassis cover.
2. Remove the two screws, located on the end of the power supply bay and one screw at the front of the power supply and under side of the chassis, as illustrated below. Set the screws aside for later use.
3. Gently slide the power supply out of the back of the chassis.
4. Replace the failed power module with another of the same model.
5. Slide the new power supply module into the power supply bay.
6. Align the holes in the power supply with the holes in the power supply bay and secure the power supply using the two screws which were set aside in step 2.
7. Replace the chassis cover, plug the power cord into the rear of the power supply and power up the system.

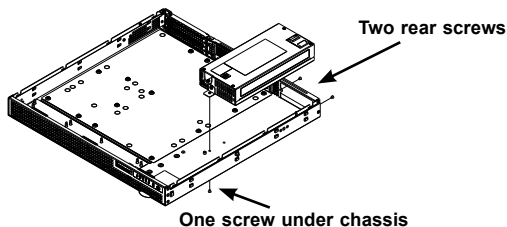
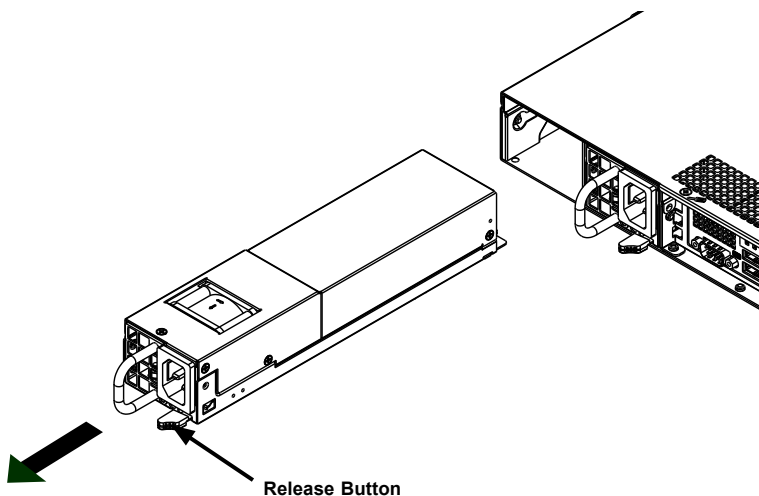

**Figure 5-13. Removing the Fixed Power Supply**

The SC514-R400C and SC514-R400W model chassis features redundant power supplies. The power supply can be changed without powering-down the server.

### ***Changing a Redundant Power Supply***

1. Press the release button on the failed power supply.
2. Use the handle to gently slide the power supply out the back of the chassis.
3. Replace the failed power module with another of the same model.
4. Slide the new power supply module into the power supply bay until it clicks into the locked position.



**Figure 5-14. Replacing a Redundant Power Supply**

## Chapter 6

# Rack Installation

### 6-1 Overview

This chapter provides a quick setup checklist to get your chassis up and running. Following these steps in the order given should enable you to have the system operational within a minimum amount of time.

### 6-2 Unpacking the System

You should inspect the box the chassis was shipped in and note if it was damaged in any way. If the chassis itself shows damage you should file a damage claim with the carrier who delivered it.

### 6-3 Preparing for Setup

The box your chassis was shipped in should include two sets of rail assemblies, two rail mounting brackets and the mounting screws you will need to install the system into the rack. Please read this section in its entirety before you begin the installation procedure outlined in the sections that follow.

Decide on a suitable location for the rack unit that will hold your chassis. It should be situated in a clean, dust-free area that is well ventilated. Avoid areas where heat, electrical noise and electromagnetic fields are generated. You will also need it placed near a grounded power outlet. Be sure to read the Rack and Server Precautions in the next section.

#### Choosing a Setup Location

- Leave enough clearance in front of the rack to enable you to open the front door completely (~25 inches).
- Leave approximately 30 inches of clearance in the back of the rack to allow for sufficient airflow and ease in servicing.
- This product is for installation only in a Restricted Access Location (dedicated equipment rooms, service closets and the like).

## **Rack Precautions**

- Ensure that the leveling jacks on the bottom of the rack are fully extended to the floor with the full weight of the rack resting on them.
- In single rack installation, stabilizers should be attached to the rack.
- In multiple rack installations, the racks should be coupled together.
- Always make sure the rack is stable before extending a component from the rack.
- You should extend only one component at a time - extending two or more simultaneously may cause the rack to become unstable.

## **General Server Precautions**

- Review the electrical and general safety precautions that came with the components you are adding to your chassis.
- Determine the placement of each component in the rack *before* you install the rails.
- Install the heaviest server components on the bottom of the rack first, and then work up.
- Use a regulating uninterruptible power supply (UPS) to protect the server from power surges, voltage spikes and to keep your system operating in case of a power failure.
- Allow the hot plug hard drives and power supply modules to cool before touching them.
- Always keep the rack's front door and all panels and components on the servers closed when not servicing to maintain proper cooling.

## **Rack Mounting Considerations**

### ***Ambient Operating Temperature***

If installed in a closed or multi-unit rack assembly, the ambient operating temperature of the rack environment may be greater than the ambient temperature of the room. Therefore, consideration should be given to installing the equipment in an

environment compatible with the manufacturer's maximum rated ambient temperature (Tmra).

### ***Reduced Airflow***

Equipment should be mounted into a rack so that the amount of airflow required for safe operation is not compromised.

### ***Mechanical Loading***

Equipment should be mounted into a rack so that a hazardous condition does not arise due to uneven mechanical loading.

### ***Circuit Overloading***

Consideration should be given to the connection of the equipment to the power supply circuitry and the effect that any possible overloading of circuits might have on overcurrent protection and power supply wiring. Appropriate consideration of equipment nameplate ratings should be used when addressing this concern.

### ***Reliable Ground***

A reliable ground must be maintained at all times. To ensure this, the rack itself should be grounded. Particular attention should be given to power supply connections other than the direct connections to the branch circuit (i.e. the use of power strips, etc.).



To prevent bodily injury when mounting or servicing this unit in a rack, you must take special precautions to ensure that the system remains stable. The following guidelines are provided to ensure your safety:

- This unit should be mounted at the bottom of the rack if it is the only unit in the rack.
- When mounting this unit in a partially filled rack, load the rack from the bottom to the top with the heaviest component at the bottom of the rack.
- If the rack is provided with stabilizing devices, install the stabilizers before mounting or servicing the unit in the rack.
- Slide rail mounted equipment is not to be used as a shelf or a work space.

## 6-4 Rack Mounting Instructions

This section provides information on installing the SC514 chassis into a rack unit with the rails provided. There are a variety of rack units on the market, which may mean the assembly procedure will differ slightly. You should also refer to the installation instructions that came with the rack unit you are using.

**NOTE:** This rail will fit a rack between 26" and 33.5" deep.

### Identifying the Sections of the Rack Rails

The chassis package includes two rack rail assemblies in the rack mounting kit. Each assembly consists of two sections: an inner fixed chassis rail that secures directly to the server chassis and an outer fixed rack rail that secures directly to the rack itself.

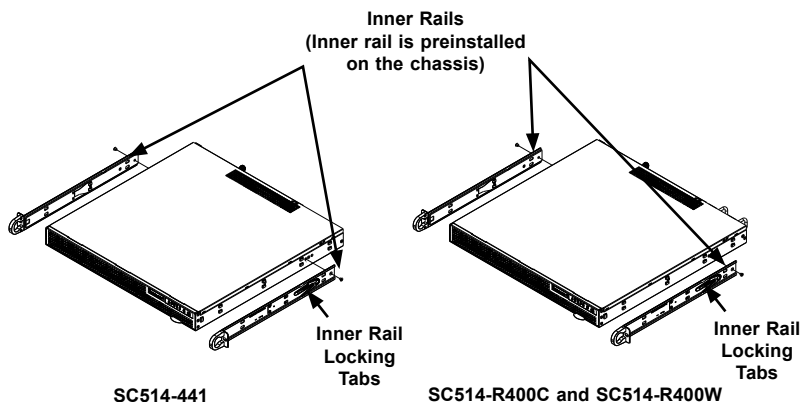
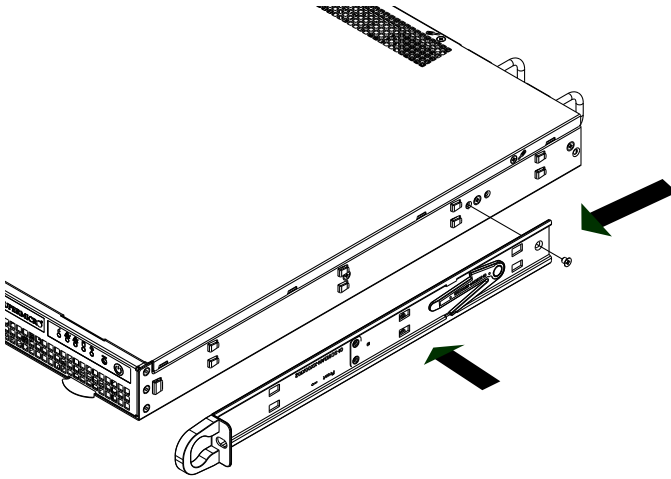

Figure 6-1: Identifying the Sections of the Inner Rails

### Locking Tabs

Both chassis rails have a locking tab. The tabs lock the server into place when installed and pushed fully into the rack. These tabs also lock the server in place when fully extended from the rack. This prevents the server from coming completely out of the rack when you pull it out for servicing.



**Figure 6-2: Installing the Inner Rail  
(Right side inner rail shown)**

## Installing The Inner Rail

The inner rails are pre-attached to the chassis, but should the need arise to remove them reinstallation of the rails is simple and can be accomplished with a standard head screwdriver.

### *Installing the Inner Rails*

1. Place the inner rail on the side of the chassis aligning the hooks of the chassis with the inner rail holes.
2. Slide the extension toward the front of the chassis.
3. Secure the chassis with one screw as illustrated. Repeat steps 1-3 for the other inner rail.



**Warning:** Do not pick up the server by the front handles. They are designed to pull the system from a rack only.

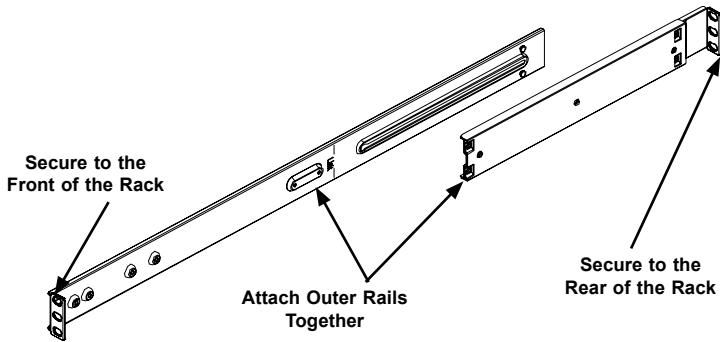

**Figure 6-3: Assembling the Outer Rails**

## Outer Rack Rails

Outer rails attach to the server rack and hold the server in place. The outer rails for the SC514 chassis extend between 30 inches and 33 inches.

### *Installing the Outer Rails to the Rack*

1. Attach the short bracket to the outside of the long bracket. Align the pins of the rail with the slides. The ends of each bracket must angle in the same direction.
2. Adjust both the short and long brackets to the proper distance so that the rail fits snugly into the rack.
3. Secure the long bracket to the front side of the outer rail with two M5 screws and the short bracket to the rear side of the outer rail with three M5 screws.
4. Repeat steps 1-3 for the remaining outer rail.



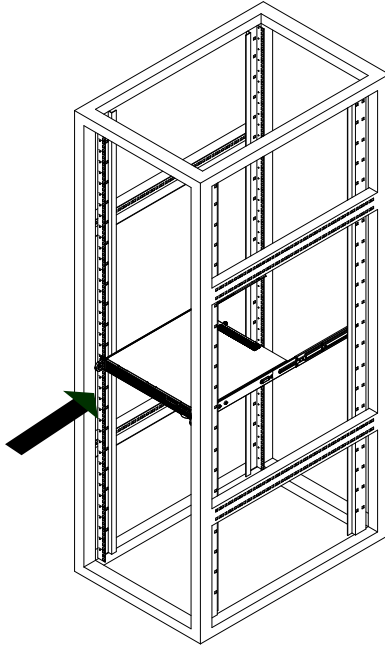

**Figure 6-4: Installing into a Rack**

**Note:** figures are for illustrative purposes only. Always install servers into racks from the bottom up.

#### ***Installing the Chassis into a Rack***

1. Confirm that chassis includes the inner rails and rail extensions. Also, confirm that the outer rails are installed on the rack.
2. Align the chassis rails with the front of the rack rails.
3. Slide the chassis rails into the rack rails, keeping the pressure even on both sides (It may be necessary to depress the locking tabs when inserting). When the server has been pushed completely into the rack, the locking tabs will "click" into the locked position.
4. (Optional) Insert and tightening the thumbscrews that hold the front of the server to the rack.



Stability hazard. The rack stabilizing mechanism must be in place, or the rack must be bolted to the floor before you slide the unit out for servicing. Failure to stabilize the rack can cause the rack to tip over.

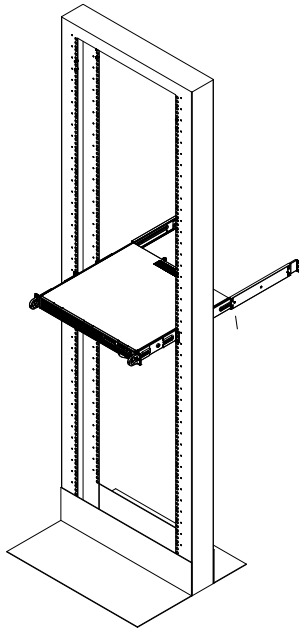

**Figure 6-5: Installing into an Open Rack**

Note: These figures are for illustrative purposes only. Always install servers into racks from the bottom up. The chassis shown may differ from the one you have purchased.

***Installing the Chassis into a Mid-Mount Position (Telco) Rack***

1. Use the two L-shaped brackets (four total) to suspend the sides of the chassis within the rack.
2. Determine how far the chassis will extend out the front of the rack. Larger chassis should be positioned to balance the weight between front and back. If a bezel is included on your server, remove it.
3. Attach the two front brackets to each side of the chassis, then the two rear brackets positioned with just enough space to accommodate the width of the telco rack.
4. Finish by sliding the chassis into the rack and tightening the brackets to the rack.

## Appendix A

### SC514 Chassis Cables

#### A-1 Overview

This appendix lists supported cables for your chassis system. It only includes the most commonly used components and configurations. For more compatible cables, refer to the manufacturer of the motherboard you are using and our Web site at: [www.supermicro.com](http://www.supermicro.com).

#### A-2 Cables Included with SC514 Chassis

SC514-441, SC514-R400C, SC514-R400W			
Part #	Type	Length	Description
CBL-0156L	Cable	15.7" (40 cm)	Front ctrl cable Round 16 pin to 16 pin, 40 cm, 28 AWG
CBL-0260L		6'	US power cord 18AWG 6ft, PBF (default for low watt)

## **A-4 Compatible Cables**

These cables are compatible with the SC514 chassis.

### **Alternate SAS/SATA Cables**

Some compatible motherboards have different connectors. If your motherboard has only one SAS connector that the SAS/SATA cables must share, use one of the following cables. These cables must be purchased separately.

- CBL-0484L
- CBL-0227L

## Extending Power Cables

Although Supermicro chassis are designed with to be efficient and cost-effective, some compatible motherboards have power connectors located in different areas.

To use these motherboards you may have to extend the power cables to the motherboards. To do this, use the following chart as a guide.

<b>Power Cable Extenders</b>		
<b>Number of Pins</b>	<b>Cable Part #</b>	<b>Length</b>
24-pin	CBL-0042	7.9" (20 cm)
20-pin	CBL-0059	7.9" (20 cm)
8-pin	CBL-0062	7.9" (20 cm)
4-pin	CBL-0060	7.9" (20 cm)

## Front Panel to the Motherboard

The SC514 chassis includes a cable to connect the chassis front panel to the motherboard. If your motherboard uses a different connector, use the following list to find a compatible cable.

<b>Front Panel to Motherboard Cable (Ribbon Cable)</b>		
<b>Number of Pins (Front Panel)</b>	<b>Number of Pins (Motherboard)</b>	<b>Cable Part #</b>
16-pin	16-pin	CBL-0049
16-pin	20-pin	CBL-0048
20-pin	20-pin	CBL-0047
16-pin	Split*	CBL-0068
20-pin	Split*	CBL-0067

\* Split cables: Use these cables if your motherboard has different pin definitions than a Supermicro motherboard.

## Notes

## Appendix B

### Power Supply Specifications

This appendix lists power supply specifications.

<b>SC514-441</b>	
	<b>440/480 W</b>
<b>MFR Part #</b>	PWS-441P-1H
<b>AC Input</b>	100-140 V, 5.5-4 Amp 50-60 Hz 180-240 V 3.5-2.5 Amp 50-60 Hz
<b>DC Output +5V</b>	18 Amp
<b>DC Output +12V</b>	440 W: 38.8A at 100-140Vac 480 W: 39.1A at 180-240Vac
<b>DC Output 3.3V</b>	15 Amp
<b>DC Output +5V standby</b>	3 Amp



<b>SC514-R400C, SC514-R400W</b>	
	<b>400W</b>
<b>MFR Part #</b>	PWS-406P-1R
<b>AC Input</b>	100-240 V, 50-60 Hz, 6-3 Amp
<b>DC Output +5V standby</b>	3 Amp
<b>DC Output +12V</b>	33 Amp
<b>With Power Distributor</b>	+5V: 25 Amp +3.3V: 25 Amp -12V: 0.6 Amp



## Notes