



HP ProBook 640 G1 Notebook PC
HP ProBook 645 G1 Notebook PC
HP ProBook 650 G1 Notebook PC
HP ProBook 655 G1 Notebook PC

Maintenance and Service Guide

IMPORTANT! This document is intended for HP
authorized service providers only.

© Copyright 2013 Hewlett-Packard
Development Company, L.P.

Bluetooth is a trademark owned by its proprietor and used by Hewlett-Packard Company under license. Intel and Core are U.S. registered trademarks of Intel Corporation. AMD is a trademark of Advanced Micro Devices, Inc. Microsoft and Windows are U.S. registered trademarks of the Microsoft group of companies. SD Logo is a trademark of its proprietor.

The information contained herein is subject to change without notice. The only warranties for HP products and services are set forth in the express warranty statements accompanying such products and services. Nothing herein should be construed as constituting an additional warranty. HP shall not be liable for technical or editorial errors or omissions contained herein.

First Edition: November 2013

Document Part number: 728342-001

Product notice

This guide describes features that are common to most models. Some features may not be available on your computer.

Not all features are available in all editions of Windows 8. This computer may require upgraded and/or separately purchased hardware, drivers, and/or software to take full advantage of Windows 8 functionality. See <http://www.microsoft.com> for details.

Software terms

By installing, copying, downloading, or otherwise using any software product preinstalled on this computer, you agree to be bound by the terms of the HP End User License Agreement (EULA). If you do not accept these license terms, your sole remedy is to return the entire unused product (hardware and software) within 14 days for a refund subject to the refund policy of your place of purchase.

For any further information or to request a full refund of the computer, please contact your local point of sale (the seller).

Safety warning notice

 **WARNING!** To reduce the possibility of heat-related injuries or of overheating the computer, do not place the computer directly on your lap or obstruct the computer air vents. Use the computer only on a hard, flat surface. Do not allow another hard surface, such as an adjoining optional printer, or a soft surface, such as pillows or rugs or clothing, to block airflow. Also, do not allow the AC adapter to contact the skin or a soft surface, such as pillows or rugs or clothing, during operation. The computer and the AC adapter comply with the user-accessible surface temperature limits defined by the International Standard for Safety of Information Technology Equipment (IEC 60950).

Table of contents

1 Product description	1
2 External component identification	10
Display	10
Buttons and fingerprint reader (select models only)	12
Keys	13
Lights	15
TouchPad	17
Front	17
Left side	18
Right side	21
Rear (select models only)	22
Bottom	23
3 Illustrated parts catalog	25
Service tag	25
Computer major components	27
Display assembly subcomponents	38
Cables	39
Plastics Kit	40
Mass storage devices	41
Miscellaneous parts	42
Sequential part number listing	43
4 Removal and replacement procedures preliminary requirements	57
Tools required	57
Service considerations	57
Plastic parts	57
Cables and connectors	58
Drive handling	58
Grounding guidelines	58
Electrostatic discharge damage	58
Packaging and transporting guidelines	60
Workstation guidelines	60

5 Removal and replacement procedures for Customer Self-Repair parts	62
Component replacement procedures	62
Battery	63
Service cover	64
Hard drive	65
Modem module (select models only)	67
Primary memory module	68
Expansion memory module	71
WWAN module (select models only)	73
WLAN module	74
Optical drive	76
Solid-state drive	78
Keyboard	79
6 Removal and replacement procedures for Authorized Service Provider parts	85
Fan and heat sink assembly	85
Base enclosure	89
USB board	92
Power button board	94
Fingerprint reader board	96
Smart card reader	98
System board	99
Speakers	104
Function button board	106
Processor	108
TouchPad	110
Power connector cable	112
RTC battery	113
Display assembly	115
7 Computer Setup	120
Windows 8 — Computer Setup (BIOS), MultiBoot, and System Diagnostics	120
Using Computer Setup	120
Starting Computer Setup	120
Navigating and selecting in Computer Setup	120
Restoring default settings in Computer Setup	121
Updating the BIOS	121
Determining the BIOS version	121
Downloading a BIOS update	122
Using MultiBoot	123

About the boot device order	123
Choosing MultiBoot preferences	123
Setting a new boot order in Computer Setup	123
Dynamically choosing a boot device using the f9 prompt	124
Setting a MultiBoot Express prompt	124
Entering MultiBoot Express preferences	124
Using HP PC Hardware Diagnostics (UEFI) (select models only)	125
Downloading HP PC Hardware Diagnostics (UEFI) to a USB device	125
Windows 7 — Computer Setup (BIOS), MultiBoot, and HP PC Hardware Diagnostics (UEFI)	125
Using Computer Setup	125
Starting Computer Setup	126
Navigating and selecting in Computer Setup	126
Restoring factory settings in Computer Setup	126
Updating the BIOS	128
Determining the BIOS version	128
Downloading a BIOS update	128
Using MultiBoot	129
About the boot device order	129
Choosing MultiBoot preferences	129
Setting a new boot order in Computer Setup	130
Dynamically choosing a boot device using the f9 prompt	130
Setting a MultiBoot Express prompt	130
Entering MultiBoot Express preferences	131
Using HP PC Hardware Diagnostics (UEFI) (select models only)	132
Downloading HP PC Hardware Diagnostics (UEFI) to a USB device	132
8 Specifications	133
Computer specifications	133
Hard drive specifications	133
Hard drive specifications (continued)	134
9 Backup and recovery	136
Windows 8	136
Backing up your information	136
Performing a system recovery	136
Using the Windows recovery tools	137
Using f11 recovery tools	137
Using Windows operating system media (purchased separately)	138
Using Windows Refresh or Windows Reset	139
Using HP Software Setup	139
Windows 7	140

Creating recovery media and backups	140
Guidelines	140
Creating recovery media with HP Recovery Disc Creator (select models only)	140
Creating recovery media	141
Backing up your information	141
Performing a system recovery	142
Using the Windows recovery tools	143
Using f11 recovery tools (select models only)	144
Using Windows 7 operating system media	144
SUSE Linux – Backup and recovery	146
Creating backups	146
Backing up your information	146
Performing a system recovery	147
Remove everything and reinstall SLED	147
10 Statement of Volatility	149
Non-volatile memory usage	150
Questions and answers	152
11 Power cord set requirements	154
Requirements for all countries	154
Requirements for specific countries and regions	154
12 Recycling	156
Index	157

1 Product description

Category	Description
Product Name	HP ProBook 640 G1 Notebook PC HP ProBook 645 G1 Notebook PC HP ProBook 650 G1 Notebook PC HP ProBook 655 G1 Notebook PC
Processors	<ul style="list-style-type: none">• Intel® Dual Core i7-4600M 2.90-GHz processor (up to 3.6-GHz), 4.0-MB, (1600-MHz FSB, 4.0-MB L3 cache, 37W)• Intel Dual Core i5-4330M 2.80-GHz processor (1600-MHz FSB, 3.0-MB L3 cache, 37 W)• Intel Dual Core i5-4300M 2.60-GHz processor (1600-MHz FSB, 3.0-MB L3 cache, 37 W)• Intel Dual Core i5-4200M 2.50-GHz processor (1600-MHz FSB, 3.0-MB L3 cache, 37 W)• Intel Dual Core i3-4100M 2.50-GHz processor (1600-MHz FSB, 3.0-MB L3 cache, 37 W)• Intel Dual Core i3-4000M 2.40-GHz processor (1600-MHz FSB, 3.0-MB L3 cache, 37 W)• AMD® Quad Core A10-5750M with Radeon HD 8650G Graphics (3.5 GHz/2.5 GHz; 4.0-MB L2 cache, 35W)• AMD Quad Core A10-4600M with Radeon HD 7660G Graphics (3.2 GHz/2.3 GHz; 4.0-MB L2 cache, 35W)• AMD Quad Core A8-5550M with Radeon HD 8550G Graphics (3.1 GHz/2.1 GHz; 4.0-MB L2 cache, 35W)• AMD Quad Core A8-4500M with Radeon HD 7640G Graphics (2.8 GHz/1.9 GHz; 4.0-MB L2 cache, 35W)• AMD Quad Core A6-5350M with Radeon HD 8450G Graphics (3.5 GHz/2.9 GHz; 4.0-MB L2 cache, 35W)• AMD Quad Core A6-4400M with Radeon HD 7520G Graphics (3.2 GHz/2.7 GHz; 4.0-MB L2 cache, 35W)• AMD Quad Core A4-5150M with Radeon HD 8350G Graphics (3.3 GHz/2.7 GHz; 4.0-MB L2 cache, 35W)• AMD Quad Core A4-4300M with Radeon HD 7420G Graphics (3.0 GHz/2.5 GHz; 4.0-MB L2 cache, 35W)
Chipset	Mobile IntelQM87 Mobile Intel HM87
Fusion Controller Hub	AMD A76M Fusion Controller Hub (FCH)

Category	Description
Graphics	Switchable graphics: <ul style="list-style-type: none"><li data-bbox="616 264 1142 296">• Intel HD Graphics 4600 with shared video memory<li data-bbox="616 308 903 340">• AMD Radeon HD 8750M Support for hybrid (switchable) graphics Frame buffer width 128-bit Support dual-display ports through the dock Support for up to 4 total displays with discrete configurations (through Advanced Docking Station) Support AMD Eyefinity Technology (with AMD Discrete graphics)

Category	Description
Panel	<ul style="list-style-type: none"> 14.0-in full high-definition (FHD) AG UWA, SVA (1920x1080 resolution, 300 nits, 72% CG, 1.3-mm + PSR slim design eDP panel) with camera and WWAN 14.0-in full high-definition (FHD) AG UWA, SVA (1920x1080 resolution, 300 nits, 72% CG, 1.3-mm + PSR slim design eDP panel) with WWAN 14.0-in full high-definition (FHD) AG UWA, SVA (1920x1080 resolution, 300 nits, 72% CG, 1.3-mm + PSR slim design eDP panel) with WWAN 14.0-in full high-definition (FHD) AG UWA, SVA (1920x1080 resolution, 300 nits, 72% CG, 1.3-mm + PSR slim design eDP panel) 14.0-in HD AG SVA (1600x1900 resolution, 250 nits, 45% CG, 1.2-mm flat design eDP panel) with camera and WWAN 14.0-in HD AG SVA (1600x1900 resolution, 250 nits, 45% CG, 1.2-mm flat design eDP panel) with WWAN 14.0-in HD AG SVA (1600x1900 resolution, 250 nits, 45% CG, 1.2-mm flat design eDP panel) with camera 14.0-in HD AG SVA (1600x1900 resolution, 250 nits, 45% CG, 1.2-mm flat design eDP panel) 14.0-in HD AG SVA (1366x768 resolution, 200 nits, 45% CG, 1.2-mm flat design eDP panel) with camera and WWAN 14.0-in HD AG SVA (1366x768 resolution, 200 nits, 45% CG, 1.2-mm flat design eDP panel) with WWAN 14.0-in HD AG SVA (1366x768 resolution, 200 nits, 45% CG, 1.2-mm flat design eDP panel) with camera 14.0-in HD AG SVA (1366x768 resolution, 200 nits, 45% CG, 1.2-mm flat design eDP panel) 15.6-in, full high-definition (FHD), AntiGlare (AG) SVA (1920x1080 resolution, 300 nits, 60% CG, 1.2-mm slim design eDP panel) with camera and WWAN 15.6-in FHD AG SVA (1920x1080 resolution, 300 nits, 60% CG, 1.2-mm slim design eDP panel) with WWAN 15.6-in FHD AG SVA (1920x1080 resolution, 300 nits, 60% CG, 1.2-mm slim design eDP panel) with camera 15.6-in FHD AG SVA (1920x1080 resolution, 300 nits, 60% CG, 1.2-mm slim design eDP panel) 15.6-in (1366x768 resolution) 200 nits, 45% CG, 1.2-mm flat design eDP panel) with camera and WWAN 15.6-in (1366x768 resolution) 200 nits, 45% CG, 1.2-mm flat design eDP panel) with WWAN 15.6-in (1366x768 resolution) 200 nits, 45% CG, 1.2-mm flat design eDP panel) with camera 15.6-in HD AG SVA (1366x768 resolution) 200 nits, 45% CG, 1.2-mm flat design eDP panel)
	All panels are 16:9 aspect ratio

Category	Description
Memory	<p>Two customer-accessible/upgradable memory module slots</p> <p>Support for DDR3L 1600-MHz PC3-12800 dual channel memory</p> <p>Support for 16384-MB of system RAM in the following configurations:</p> <ul style="list-style-type: none"> • 16384-MB total system memory (8192-MB×2 or 4096-MB×4) • 12288-MB Total system memory (8192-MB + 4096-MB) • 8192-MB total system memory (8192-MB or 4096-MB×2) • 8192-MB total system memory (8192-MB×1) • 6144-MB Total system memory (4096-MB + 2048-MB) • 4096-MB total system memory (4096-MB×1) • 2048-MB total system memory (2048-MB×1)
Flash cache	<p>32-GB MLC SATA-3 module (Intel Smart Response Technology (SRT))</p> <p>Dedicated MiniCard slot</p> <p>Support for no flash cache option</p> <p>Fast Flash Standby not supported</p> <p>Not available on computer models equipped with WWAN capability, a solid-state drive (SSD), or a self-encrypted drive (SED)</p> <p>Not available on computer models equipped with the Linux operating system</p>
MiniCard solid-state drive	<p>256-GB SATA-3 SSD</p> <p>180-GB SATA-3 SSD</p> <p>128-GB mSATA SSD</p> <p>SSD is set as primary storage if selected; hard drive becomes secondary storage</p>

Category	Description
Hard drive	<p>Support for 6.35-cm (2.5-in) hard drives in 7.0-mm (.28-in) and 9.5-mm (.37-in) thickness</p> <p>Support for Serial ATA</p> <p>Support for 3D DriveGuard hard drive protection</p> <p>Support toolless removal</p> <p>Support for the following hard drives:</p> <ul style="list-style-type: none"> • 1-TB, 5400-rpm, 9.5-mm • 750-GB, 7200-rpm, 7.0-mm • 500-GB, 7200-rpm, 7.0-mm • 500-GB, 5400-rpm, 7.0-mm, FIPS (not available on computer models equipped with the Windows 8, Windows 7, or Windows 8 downgrade operating systems) • 500-GB, 7200-rpm, 7.0-mm, self-encrypting drive (not available on computer models equipped with the Windows 8, Windows 7, or Windows 8 downgrade operating systems) • 320-GB, 7200-rpm, 7.0-mm <p>Support for the following 6.35-cm (2.5-in) solid-state drives:</p> <ul style="list-style-type: none"> • 256-GB SATA-3 self-encrypting SSD (not available on computer models equipped with the Windows 8, Windows 7, or Windows 8 downgrade operating systems) • 180-GB SATA-3 SSD • 128-GB SATA-3 SSD
Upgrade drive	<p>Support for the following 9.5-mm (.37-in) , SATA optical drives:</p> <ul style="list-style-type: none"> • Blu-ray ROM DVD±RW SuperMulti Double-Layer Drive • DVD±RW SuperMulti Double-Layer Drive • DVD-ROM Drive <p>Support for 6.35-cm (2.5-in) 750-GB, 7200-rpm SATA hard drive in 7.0-mm (.28-in) and 9.5-mm (.37-in) thicknesses</p> <p>Support for the following 6.35-cm (2.5-in) SATA III solid-state drives:</p> <ul style="list-style-type: none"> • 512-GB SSD • 256-GB SED SSD (not available on computer models equipped with the Windows 8, Windows 7, or Windows 8 downgrade operating systems) <p>Supports for no Upgrade drive option (bezel)</p>
Audio and video	<p>Stereo speakers</p> <p>Dual array microphone (select models only)</p> <p>HD Audio with DTS Studio sound</p> <p>DTS sound+</p> <p>Integrated HD 720p webcam (fixed [no tilt], activity LED, 1280×720 by 30 frames per second)</p> <p>Support for no webcam option</p>

Category	Description
Ethernet	<p>Intel I218-LM 10/100/1000 Ethernet, with Intel I218-LM Gigabit Network Connection (select models only)</p> <p>Realtek RTL8151GH-CG 10/100/1000 Ethernet (select models only)</p> <p>Support for Power Optimizer</p> <p>Intel Stable Image Platform Program (SIPP)</p>
Wireless	<p>Integrated wireless local area network (WLAN) options by way of wireless module</p> <p>Two WLAN antennas built into display assembly</p> <p>Support for the following WLAN formats:</p> <ul style="list-style-type: none"> • Intel 802.11 a/b/g/n 2x2 + BT 4.0 Combo Adapter • Intel 802.11 2x2 AC + BT 4.0 Combo Adapter • Intel 802.11 2x2 a/b/g/n + BT 4.0 Combo Adapter • Intel 802.11 2x2 a/b/g/n • Broadcom 802.11 a/b/g/n 2x2 + BT 4.0 LE PCIe+USB HMC WW Combo Adapter • Atheros 802.11 b/g/n 1x1 + BT 4.0 Combo Adapter • Atheros 802.11 b/g/n 1x1 <p>Integrated wireless wide area network (WWAN) options by way of wireless module (select models only)</p> <p>Two WWAN antennas built into display assembly</p> <p>Security provided by subscriber identify module (SIM), slot located in battery bay</p> <p>Support for the following WWAN formats:</p> <ul style="list-style-type: none"> • HP It4111 LTE/EV-DO/HSPA+ Mobile Broadband Module • HP It4112 LTE/HSPA+ Mobile Broadband Module • HP hs3110 HSPA+ Mobile Broadband Module
External media cards	<p>Digital Media Reader Slot with push-push technology. Reads data from and writes data to digital memory cards such as Secure Digital (SD).</p>
Ports	<ul style="list-style-type: none"> • AC adapter, HP Smart • Audio-in (mono microphone)/audio-out (stereo headphone) combo jack • Battery (secondary) • DisplayPort 1.2 • Docking • RJ-45 (Ethernet) • USB 3.0 (3 or 4) • USB 3.0 charging (1) • VGA (Dsub 15 pin) supporting: 1920×1200 external resolution @ 75 Hz, hot plug and unplug and autodetection for correct output to wide-aspect vs. standard aspect video

Category	Description
Keyboard/pointing devices	<p>Full-size, spill-resistant keyboard with drain and numeric keypad</p> <p>Gesture support: MultiTouch gestures enabled, two-finger scrolling, and pinch-zoom as default</p> <p>Support for Windows 8 dual-point (pointing stick with 3 pointing stick buttons plus TouchPad with 3 TouchPad buttons)</p> <p>DuraKeys</p> <p>Spill Resistant with drain</p> <p>TouchPad requirements:</p> <ul style="list-style-type: none"> • On/off button • Support for 2-way scroll • Taps enabled by default • Gestures enabled by default: <ul style="list-style-type: none"> ◦ 2-finger scrolling ◦ 2-finger zoom (pinch)
Power requirements	<p>Support for the following AC adapters:</p> <ul style="list-style-type: none"> • 90-W, HP Smart Adapter • 65-W, HP Smart Adapter
Power requirements <i>(continued)</i>	<p>Support for the following batteries</p> <ul style="list-style-type: none"> • 9-cell cylindrical 100-WHr, 3.0-Ah, Li-ion battery • 6-cell cylindrical 55-WHr, 2.8-Ah, Li-ion battery • 6-cell cylindrical 55-WHr, 2.55-Ah, Li-ion battery • 3-cell cylindrical 33-WHr, 2.0-Ah, Li-ion battery
Security	<p>Support security lock</p> <p>Trusted platform module (TPM) 1.2 (Infineon; soldered down) and TPM Enhanced Drive Lock (For the People's Republic of China and Asia Pacific countries and regions, disabled but available)</p> <p>Fingerprint reader (select models only)</p> <p>Integrated smart card reader</p>

Category	Description
Operating system	<p>Preinstalled:</p> <ul style="list-style-type: none"> • Windows 8.1 Professional 64-bit • Windows 8.1 Professional 64-bit (MSNA) • Win 8.1 Professional 64-bit DPK with Windows 7 Professional 64-bit Image • Win 8.1 Professional 64-bit DPK with Windows 7 Professional 32-bit Image • Windows 8.1 Chinese Market 64-bit • Windows 8.1 Emerging Market 64-bit • Windows 8.1 Multi-Language 64-bit • Windows 8 Professional 64-bit • Windows 8 Multi-Language 64-bit • Windows 8 Emerging Market 64-bit • Windows 8 CH 64-bit (available only in the People's Republic of China with Hardware Kit) • Windows 8 Professional 64-bit DPK with Windows 7 Professional 64-bit Image (not supported in the People's Republic of China) • Windows 7 Professional 64-bit • Windows 7 Professional 64-bit MSNA • Windows 7 Professional 32-bit • Windows 7 Professional 32-bit MSNA • Windows 7 Home Premium 64-bit • Windows 7 Home Premium 32-bit • Windows 7 Basic 32-bit • FreeDOS 2.0 • SuSE Linux Enterprise (SLED 11) Service Pack 2, 64-bit (not available on computer models equipped with WWAN capability or Blu-ray ROM DVD±RW SuperMulti Double-Layer Drive) <hr/> <p>Restore media-DRDVD:</p> <ul style="list-style-type: none"> • DRDVD Windows 8.1 (available with any Windows 8 localization, required for any Windows 8.1 Professional downgrade operating system) • DRDVD Windows 8 (available with any Windows 8 localization, required for any Windows 8 Professional downgrade operating system) • DRDVD Windows 7 (available with any Windows 8 or Windows 7 Professional downgrade loc) • SRDVD SuSE Linux Enterprise (SLED) Service Pack 2, 64-bit (available with FreeDOS and SuSE Linux)

Category	Description
Operating system <i>(continued)</i>	<p>Restore media-OSDVD:</p> <ul style="list-style-type: none"> • Windows 8.1 64-bit (available only and required with Windows 8 Downgrade OS except ASIA and the People's Republic of China) • Windows 8 64-bit (for service only) • Windows 8 Country-Specific 64-bit (for service only) • Windows 8 Emerging Market 64-bit (for service only) • Windows 8 Professional 64-bit (available only and required with Windows 8 downgrade operating systems) • Windows 7 Professional 64-bit (available with any Windows 8 Professional or Windows 7 Professional downgrade loc, not available in the People's Republic of China) <hr/> <p>Certified:</p> <ul style="list-style-type: none"> • Microsoft WHQL • SuSE Linux Enterprise (SLED) Service Pack 2, 64-bit <hr/> <p>Web-only support:</p> <ul style="list-style-type: none"> • Windows 8.1 Professional 64-bit • Windows 8.1 Enterprise 64-bit • Windows 8.1 Multi-Language 64-bit • Windows 8.1 Emerging Market 64-bit • Windows 8.1 Chinese Market 64-bit • Windows 8 Enterprise 64-bit • Windows 7 Ultimate 64-bit • Windows 7 Ultimate 32-bit • Windows 7 Enterprise 64-bit • Windows 7 Enterprise 32-bit • Windows 7 Professional 32-bit • Windows 7 Basic 64-bit • Windows 7 Basic 32-bit <hr/> <p>Serviceability</p> <p>End user replaceable parts:</p> <ul style="list-style-type: none"> • AC adapter • Battery (system) • Hard drive • Keyboard • Memory modules (2, one primary and one expansion) • Optical drive • SSD • WLAN module • WWAN module

2 External component identification

Display

 **NOTE:** Your computer may look slightly different from the illustration in this section.

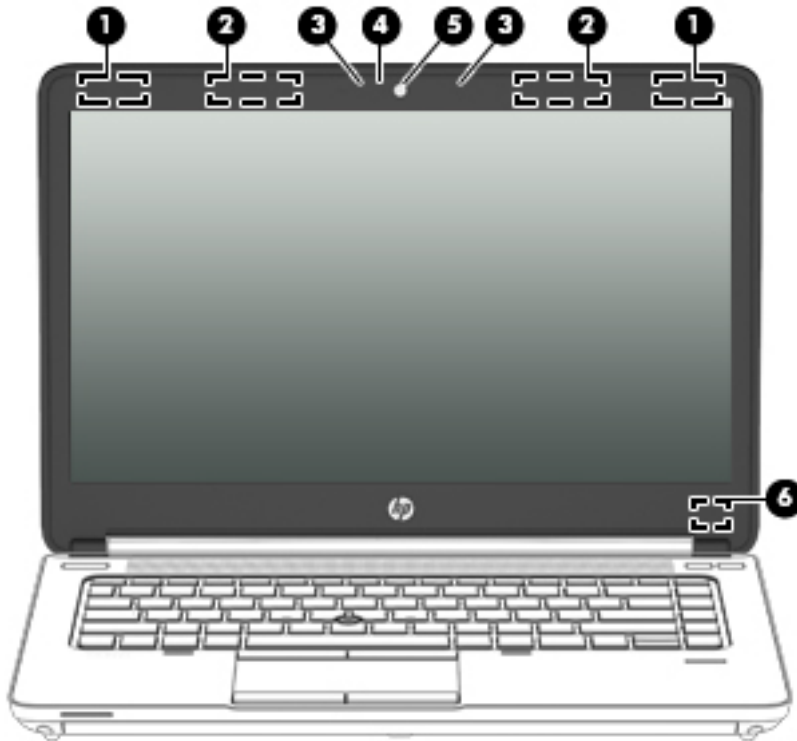

Component	Description
(1) WLAN antennas (2)*	Send and receive wireless signals to communicate with wireless local area networks (WLAN).
(2) WWAN antennas (2)* (select models only)	Send and receive wireless signals to communicate with wireless wide area networks (WWAN).
(3) Internal microphones (2)	Record sound.
(4) Webcam light	On: The webcam is in use.
(5) Webcam	Records video and captures still photographs. For information on using the webcam, access HP Support Assistant. To access HP Support Assistant on the Start screen, select the HP Support Assistant app.



Component	Description
(6) Internal display switch	Turns off the display or initiates Sleep if the display is closed while the power is on. NOTE: The display switch is not visible on the outside of the computer.

*The antennas are not visible on the outside of the computer. For optimal transmission, keep the areas immediately around the antennas free from obstructions. To see wireless regulatory notices, see the section of the *Regulatory, Safety, and Environmental Notices* that applies to your country or region. To access the user guides, select the **HP Support Assistant** app on the Start screen, select **My computer**, and then select **User guides**.

Buttons and fingerprint reader (select models only)

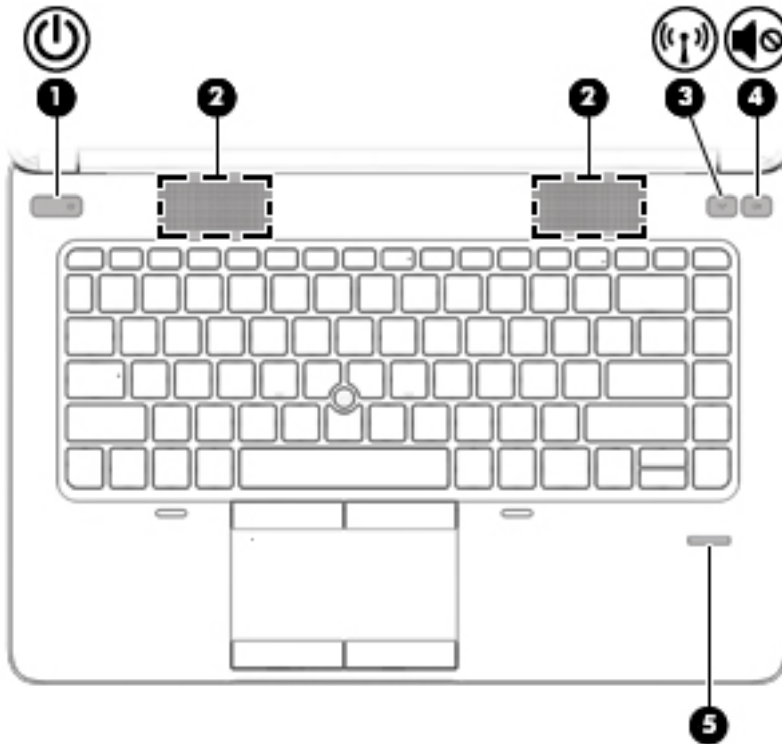
 **NOTE:** Your computer may look slightly different from the illustration in this section.





Component	Description
(1)  Power button	<ul style="list-style-type: none">• When the computer is off, press the button to turn on the computer.• When the computer is on, press the button briefly to initiate Sleep.• When the computer is in the Sleep state, press the button briefly to exit Sleep.• When the computer is in Hibernation, press the button briefly to exit Hibernation. <p>CAUTION: Pressing and holding down the power button will result in the loss of unsaved information.</p> <p>To learn more about your power settings, see your power options. From the Start screen, type <code>power</code>, select Settings, and then select Power Options.</p>
(2) Speakers (2)	Produce sound.
(3)  Wireless button	Turns the wireless feature on or off but does not establish a wireless connection.
(4)  Volume mute button	Mutes and restores speaker sound.
(5) Fingerprint reader (select models only)	Allows a fingerprint logon to Windows, instead of a password logon.

Keys

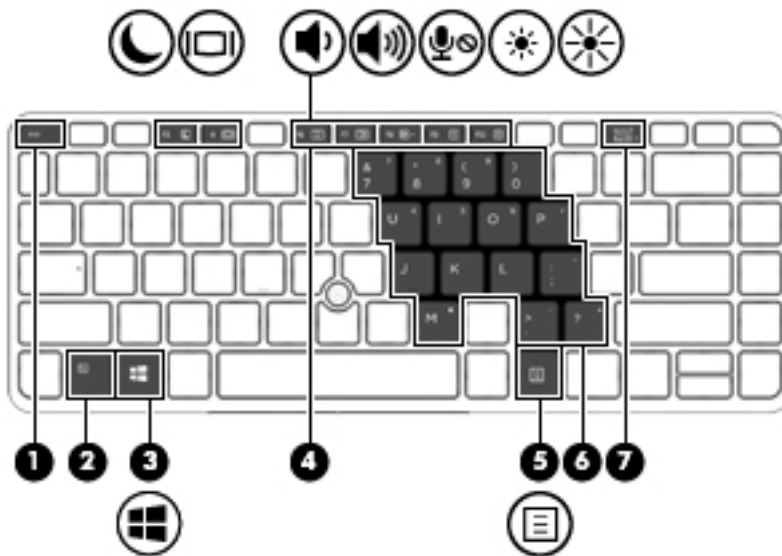
 **NOTE:** Refer to the illustration that most closely matches your computer.



Component	Description
(1) esc key	Displays system information when pressed in combination with the fn key.
(2) fn key	Executes frequently used system functions when pressed in combination with a function key, the num lk key, the esc key, or the b key.
(3)  Windows button	Returns you to the Start screen from an open app or the Windows desktop. NOTE: Pressing the Windows button again will return you to the previous screen.
(4) Function keys	Execute frequently used system functions when pressed in combination with the fn key.
(5)  Windows applications key	Displays options for a selected object.
(6) Embedded numeric keypad	When the keypad is turned on, it can be used like an external numeric keypad. Each key on the keypad performs the function indicated by the icon in the upper-right corner of the key.
(7) num lk key	Turns the embedded numeric keypad on and off when pressed in combination with the fn key.

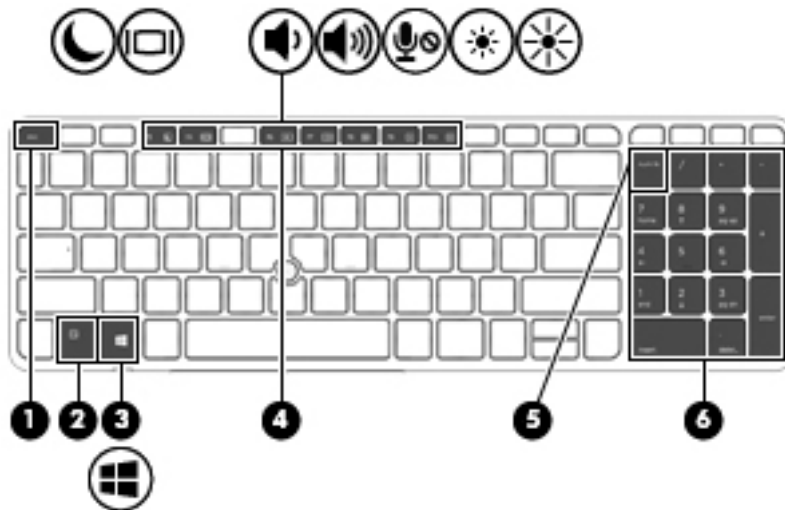





Component	Description
(1) <code>esc</code> key	Displays system information when pressed in combination with the <code>fn</code> key.
(2) <code>fn</code> key	Executes frequently used system functions when pressed in combination with a function key, the <code>num lk</code> key, the <code>esc</code> key, or the <code>b</code> key.
(3)  Windows button	Returns you to the Start screen from an open app or the Windows desktop. NOTE: Pressing the Windows button again will return you to the previous screen.
(4) Function keys	Execute frequently used system functions when pressed in combination with the <code>fn</code> key.
(5) <code>num lk</code> key	Alternates between the navigational and numeric functions on the integrated numeric keypad.
(6) Integrated numeric keypad	When <code>num lk</code> has been enabled, it can be used like an external numeric keypad.

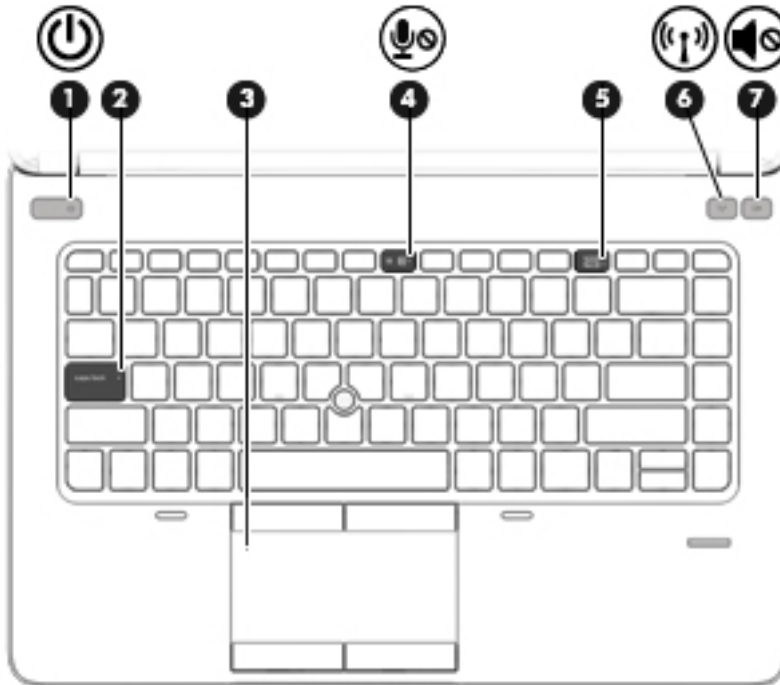



Lights

 **NOTE:** Refer to the illustration that most closely matches your computer.

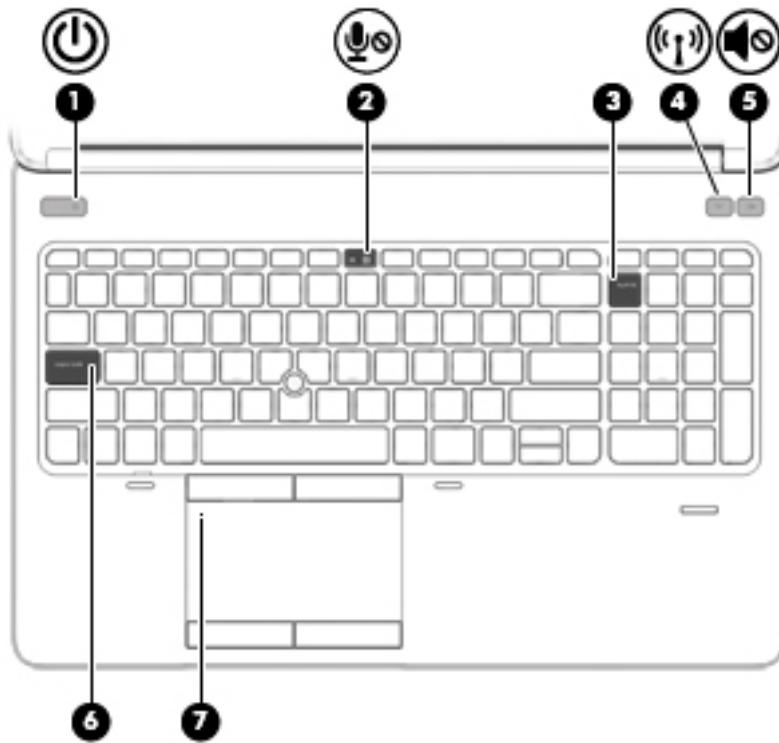

Component	Description
(1)  Power light	<ul style="list-style-type: none">• On: The computer is on.• Blinking: The computer is in the Sleep state.• Off: The computer is off.
(2) Caps lock light	On: Caps lock is on.
(3) TouchPad light	<ul style="list-style-type: none">• Amber: The TouchPad is off.• Off: The TouchPad is on.
(4)  Microphone mute light	<ul style="list-style-type: none">• Amber: Microphone sound is off.• Off: Microphone sound is on.
(5) Num lock light	On: Num lock is on.
(6)  Wireless light	<ul style="list-style-type: none">• White: An integrated wireless device, such as a wireless local area network (WLAN) device and/or a Bluetooth® device, is on.• Amber: All wireless devices are off.
(7)  Mute light	<ul style="list-style-type: none">• Amber: Computer sound is off.• White: Computer sound is on.



Component	Description
(1)  Power light	<ul style="list-style-type: none"> • On: The computer is on. • Blinking: The computer is in the Sleep state. • Off: The computer is off.
(2)  Microphone mute light	<ul style="list-style-type: none"> • Amber: Microphone sound is off. • Off: Microphone sound is on.
(3) Num lock light	On: Num lock is on.
(4)  Wireless light	<ul style="list-style-type: none"> • White: An integrated wireless device, such as a wireless local area network (WLAN) device and/or a Bluetooth® device, is on. • Amber: All wireless devices are off.
(5)  Mute light	<ul style="list-style-type: none"> • Amber: Computer sound is off. • White: Computer sound is on.
(6) Caps lock light	On: Caps lock is on.
(7) TouchPad light	<ul style="list-style-type: none"> • Amber: The TouchPad is off. • Off: The TouchPad is on.



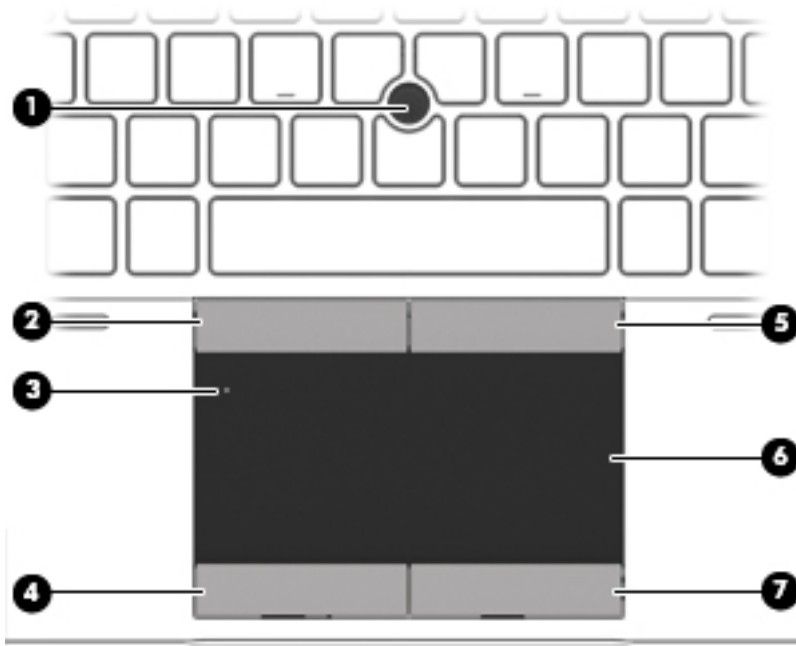

TouchPad

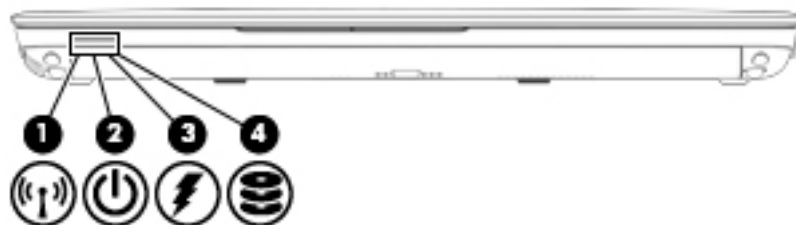

Component	Description
(1)	Pointing stick (select models only) Moves the pointer and selects or activates items on the screen.
(2)	Left pointing stick button (select models only) Functions like the left button on an external mouse.
(3)	TouchPad on/off button Turns the TouchPad on and off.
(4)	Left TouchPad button Functions like the left button on an external mouse.
(5)	Right pointing stick button (select models only) Functions like the right button on an external mouse.
(6)	TouchPad zone Moves the pointer and selects or activates items on the screen.
(7)	Right TouchPad button Functions like the right button on an external mouse.

Front





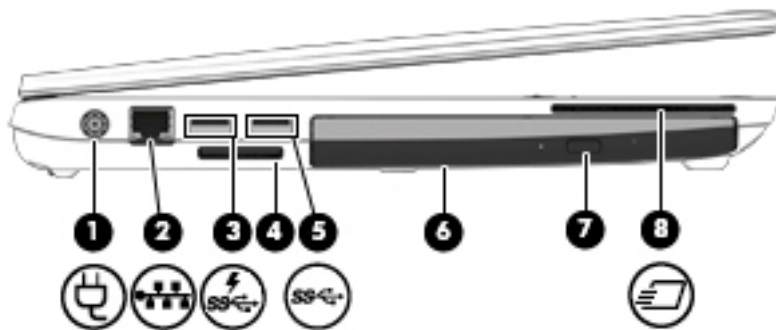

Component	Description
(1)  Wireless light	<ul style="list-style-type: none"> White: An integrated wireless device, such as a wireless local area network (WLAN) device and/or a Bluetooth® device, is on. Amber: All wireless devices are off.
(2)  Power light	<ul style="list-style-type: none"> On: The computer is on. Blinking: The computer is in the Sleep state. Off: The computer is off.
(3)  AC adapter/Battery light	<ul style="list-style-type: none"> White: The computer is connected to external power and the battery is charged from 90 to 99 percent. Amber: The computer is connected to external power and the battery is charged from 0 to 90 percent. Blinking amber: A battery that is the only available power source has reached a low battery level. When the battery reaches a critical battery level, the battery light begins blinking rapidly. Off: The battery is fully charged.
(4)  Hard drive light	<ul style="list-style-type: none"> Blinking white: The hard drive is being accessed. Amber: HP 3D DriveGuard has temporarily parked the hard drive.

Left side





 **NOTE:** Refer to the illustration that most closely matches your computer.

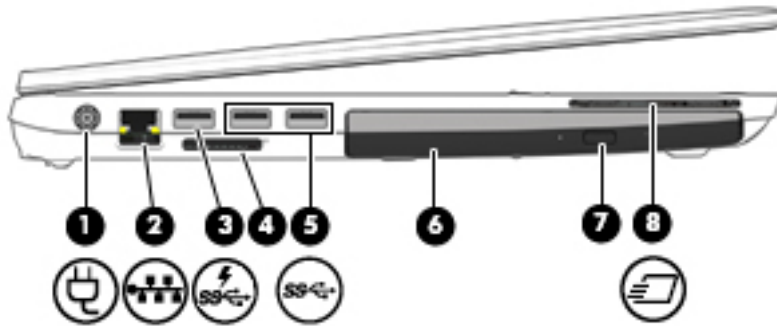

Component	Description
(1)  Power connector	Connects an AC adapter.
(2)  RJ-45 (network) jack/lights (2)	Connects a network cable. <ul style="list-style-type: none"> Amber (left): The network is showing activity. Green (right): The network is connected.

Component	Description
(3) 	Connects optional USB 3.0 devices and provides enhanced USB power performance. The USB charging port can also charge select models of cell phones and MP3players, even when the computer is off
(4)	Reads data from and writes data to memory cards such as Secure Digital (SD).
(5) 	Connects optional USB 3.0 devices and provide enhanced USB power performance.
(6)	The upgrade bay can hold either a hard drive or an optical drive that reads and writes (select models only) to an optical disc. It can also hold a weight saver option.
(7)	Releases the optical drive disc tray.
(8) 	Supports optional ExpressCards or smart cards.







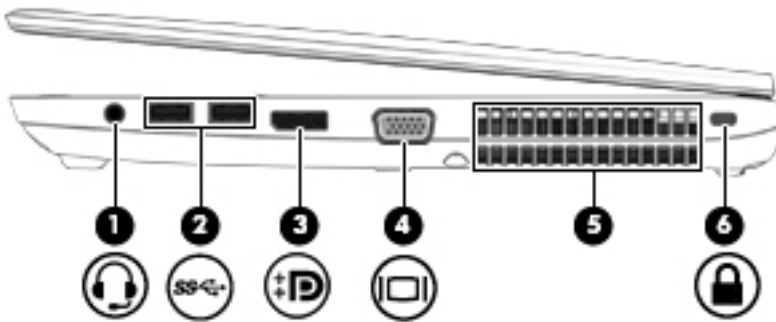

Component	Description
(1) 	Connects an AC adapter.
(2) 	Connects a network cable. <ul style="list-style-type: none"> Amber (left): The network is showing activity. Green (right): The network is connected.
(3) 	Connects optional USB 3.0 devices and provides enhanced USB power performance. The USB charging port can also charge select models of cell phones and MP3players, even when the computer is off.
(4)	Reads data from and writes data to memory cards such as Secure Digital (SD).
(5) 	Connect optional USB 3.0 devices and provide enhanced USB power performance.
(6)	The upgrade bay can hold either a hard drive or an optical drive that reads and writes (select models only) to an optical disc. It can also hold a weight saver option.

Component	Description
(7) Optical drive eject button (select models only)	Releases the optical drive disc tray.
(8)  ExpressCard slot or smart card reader (depending on the configuration)	Supports optional ExpressCards or smart cards.

Right side



 **NOTE:** Your computer may look slightly different from the illustration in this section.



Component	Description
(1)  Audio-out (headphone) jack/Audio-in (microphone) jack	<p>Produces sound when connected to optional powered stereo speakers, headphones, earbuds, a headset, or television audio. Also connects an optional headset microphone.</p> <p>WARNING! To reduce the risk of personal injury, adjust the volume before putting on headphones, earbuds, or a headset. For additional safety information, see the <i>Regulatory, Safety, and Environmental Notices</i>. To access the user guides, select the HP Support Assistant app on the Start screen, select My computer, and then select User guides.</p> <p>NOTE: When a device is connected to the jack, the computer speakers are disabled.</p> <p>NOTE: Be sure that the device cable has a 4-conductor connector that supports both audio-out (headphone) and audio-in (microphone).</p>
(2)  USB 3.0 ports (2)	Connect optional USB 3.0 devices and provide enhanced USB power performance.
(3)  Dual-Mode DisplayPort	Connects an optional digital display device, such as a high-performance monitor or projector.
(4)  External monitor port	Connects an external VGA monitor or projector.
(5) Vents (2)	<p>Enable airflow to cool internal components.</p> <p>NOTE: The computer fan starts up automatically to cool internal components and prevent overheating. It is normal for the internal fan to cycle on and off during routine operation.</p>
(6)  Security cable slot	<p>Attaches an optional security cable to the computer.</p> <p>NOTE: The security cable is designed to act as a deterrent, but it may not prevent the computer from being mishandled or stolen.</p>





Rear (select models only)

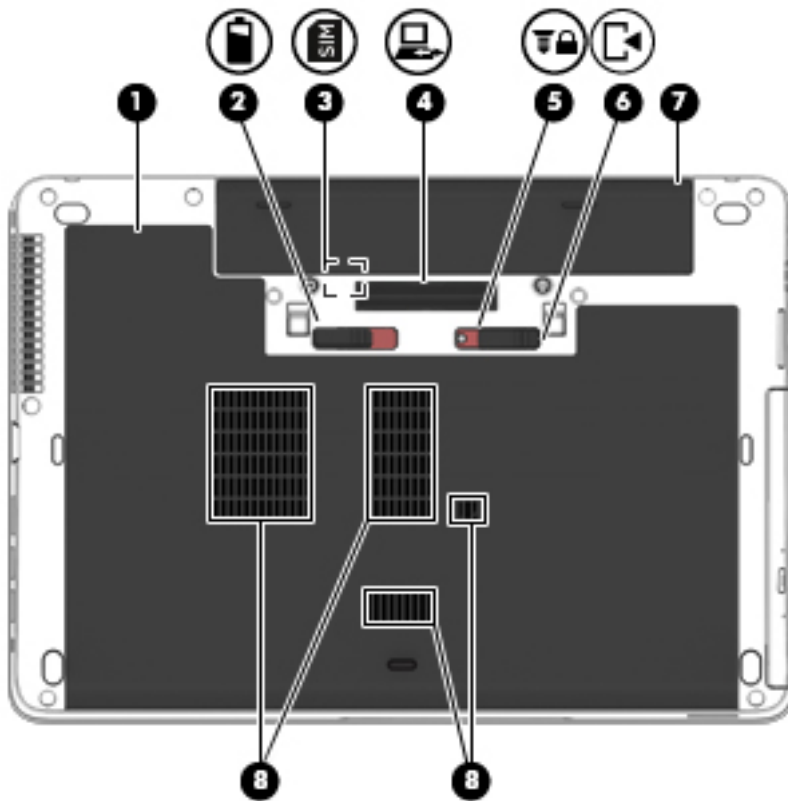

Component	Description
(1)  RJ-11 (modem) jack (select models only)	Connects a modem cable.
(2)  Serial port	Connects an optional device such as a serial modem, mouse, or printer.

Bottom



Component	Description
(1)  Service cover	Provides access to the hard drive bay, the wireless LAN (WLAN) module slot, the WWAN module slot, and the memory module slots. CAUTION: To prevent an unresponsive system, replace the wireless module only with a wireless module authorized for use in the computer by the governmental agency that regulates wireless devices in your country or region. If you replace the module and then receive a warning message, remove the module to restore computer functionality, and then contact support through HP Support Assistant. To access HP Support Assistant on the Start screen, select the HP Support Assistant app.
(2)  Battery release latch	Releases the battery.
(3)  SIM slot	Supports a wireless subscriber identity module (SIM) (select models only). The SIM slot is located inside the battery bay.
(4)  Docking connector	Connects an optional docking device.
(5)  Service cover release lock	Locks the service cover.

Component	Description
(6)  Service cover release latch	Releases the service cover on the computer.
(7) Battery bay	Holds the battery.
(8) Vents (4)	Enable airflow to cool internal components. NOTE: The computer fan starts up automatically to cool internal components and prevent overheating. It is normal for the internal fan to cycle on and off during routine operation.

3 Illustrated parts catalog

Service tag

When ordering parts or requesting information, provide the computer serial number and model number provided on the service tag.

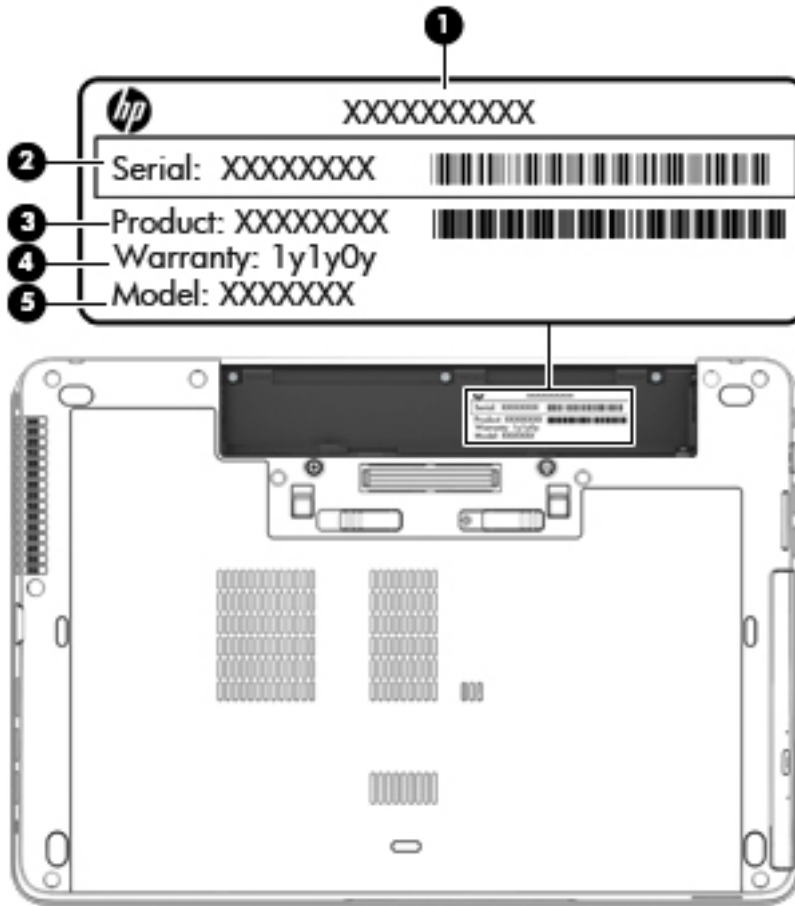

Item	Description	Function
(1)	Product name	This is the product name affixed to the front of the computer.
(2)	Serial number	This is an alphanumeric identifier that is unique to each product.
(3)	Part number/Product number	This number provides specific information about the product's hardware components. The part number helps a service technician to determine what components and parts are needed.

Item	Description	Function
(4)	Warranty period	This number describes the duration of the warranty period for the computer.
(5)	Model description	This is the alphanumeric identifier used to locate documents, drivers, and support for the computer.

Computer major components

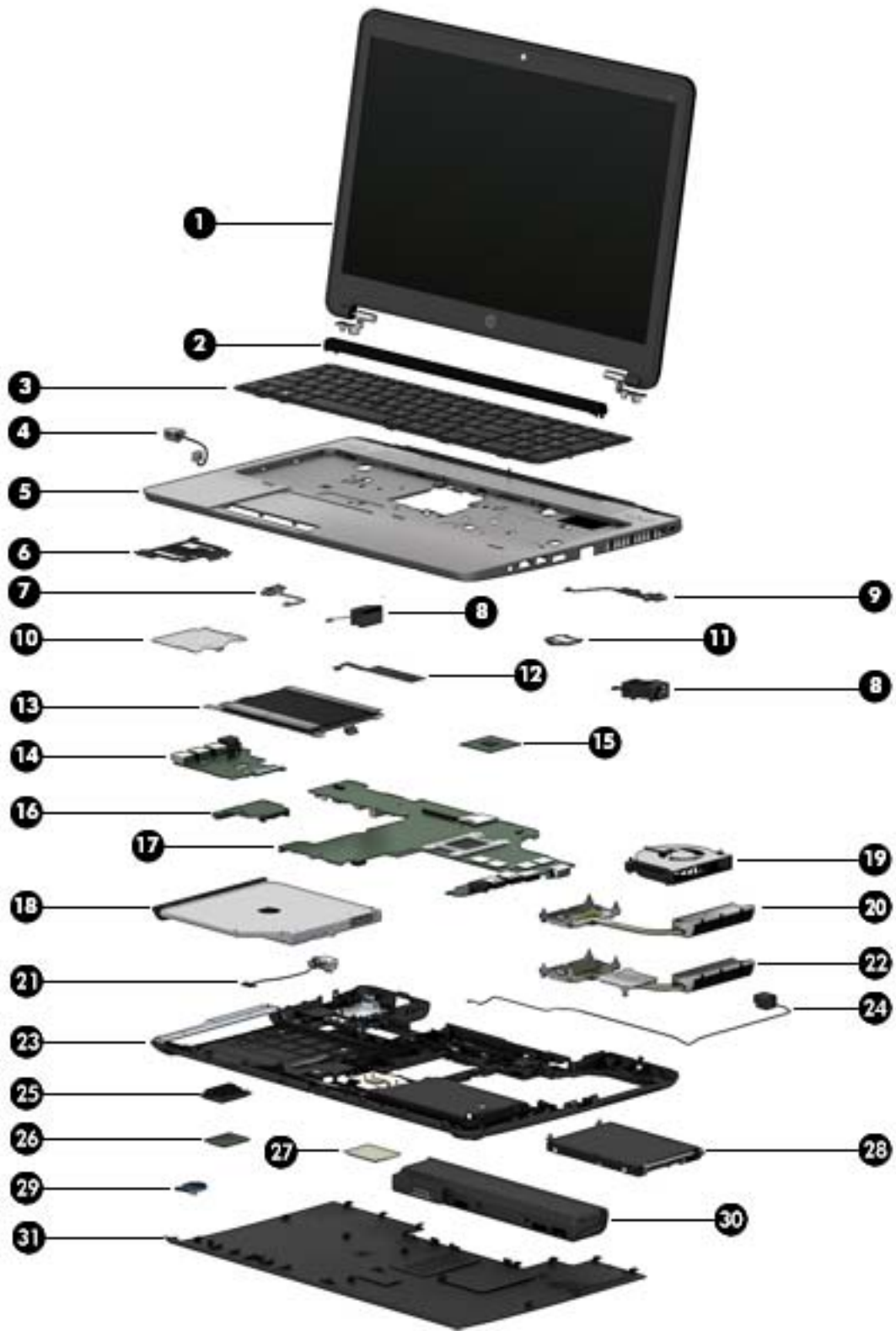

Item	Component	Spare part number
(1)	Display assembly: The display assembly is spared as a whole unit assembly only.	
	15.6-in, FHD, WLED UWVA display assembly equipped with a webcam	739998-001
	15.6-in, HD, WLED UWVA display assembly equipped with a webcam	739997-001
	14-in, HD WLED display assembly equipped with a webcam	747751-001
	14-in, HD+ WLED display assembly equipped with a webcam	747752-001
	14-in, FHD, WLED UWVA display assembly equipped with a webcam	747753-001
(2)	Top hinge cover for 15.6-in models	
(3)	Keyboard (includes keyboard cable):	
	Keyboard for 15.6-in models with pointing stick (includes keyboard cable and pointing stick cable):	
	For use in Belgium	738697-A41
	For use in Brazil	738697-201
	For use in Bulgaria	738697-261
	For use in Canada	738697-DB1
	For use in the Czech Republic and Slovakia	738697-FL1
	For use in Denmark	738697-081
	For use in France	738697-051
	For use in Germany	738697-041
	For use in Greece	738697-151
	For use in Hungary	738697-211
	For use in Iceland	738697-DD1
	For use in India	738697-D61
	For use in Israel	738697-BB1
	For use in Italy	738697-061
	For use in Japan	738697-291
	For use in Latin America	738697-161
	For use in the Netherlands	738697-B31
	For use in Northwest Africa	738697-FP1
	For use in Norway	738697-091
	For use in Portugal	738697-131
	For use in Romania	738697-271
	For use in Russia	738697-251
	For use in Saudi Arabia	738697-171
	For use in Slovenia	738697-BA1
	For use in South Korea	738697-AD1

Item	Component	Spare part number
	For use in Spain	738697-071
	For use in Sweden and Finland	738697-B71
	For use in Switzerland	738697-BG1
	For use in Taiwan	738697-AB1
	For use in Thailand	738697-281
	For use in Turkey	738697-141
	For use in the United Kingdom and Singapore	738697-031
	For use in the United States	738697-001
	Keyboard for 15.6-in models (includes keyboard cable):	
	For use in Belgium	738696-A41
	For use in Brazil	738696-201
	For use in Bulgaria	738696-261
	For use in Canada	738696-DB1
	For use in the Czech Republic and Slovakia	738696-FL1
	For use in Denmark	738696-081
	For use in France	738696-051
	For use in Germany	738696-041
	For use in Greece	738696-151
	For use in Hungary	738696-211
	For use in Iceland	738696-DD1
	For use in India	738696-D61
	For use in Israel	738696-BB1
	For use in Italy	738696-061
	For use in Japan	738696-291
	For use in Latin America	738696-161
	For use in the Netherlands	738696-B31
	For use in Northwest Africa	738696-FP1
	For use in Norway	738696-091
	For use in Portugal	738696-131
	For use in Romania	738696-271
	For use in Russia	738696-251
	For use in Saudi Arabia	738696-171
	For use in Slovenia	738696-BA1
	For use in South Korea	738696-AD1

Item	Component	Spare part number
	For use in Spain	738696-071
	For use in Sweden and Finland	738696-B71
	For use in Switzerland	738696-BG1
	For use in Taiwan	738696-AB1
	For use in Thailand	738696-281
	For use in Turkey	738696-141
	For use in the United Kingdom and Singapore	738696-031
	For use in the United States	738696-001
	Keyboard for 14" models with pointing stick (includes keyboard cable and pointing stick cable):	
	For use in Belgium	738688-A41
	For use in Brazil	738688-201
	For use in Bulgaria	738688-261
	For use in Canada	738688-DB1
	For use in the Czech Republic and Slovakia	738688-FL1
	For use in Denmark	738688-081
	For use in France	738688-051
	For use in Germany	738688-041
	For use in Greece	738688-151
	For use in Hungary	738688-211
	For use in Iceland	738688-DD1
	For use in India	738688-D61
	For use in Israel	738688-BB1
	For use in Italy	738688-061
	For use in Japan	738688-291
	For use in Latin America	738688-161
	For use in the Netherlands	738688-B31
	For use in Northwest Africa	738688-FP1
	For use in Norway	738688-091
	For use in Portugal	738688-131
	For use in Romania	738688-271
	For use in Russia	738688-251
	For use in Saudi Arabia	738688-171
	For use in Slovenia	738688-BA1
	For use in South Korea	738688-AD1

Item	Component	Spare part number
	For use in Spain	738688-071
	For use in Sweden and Finland	738688-B71
	For use in Switzerland	738688-BG1
	For use in Taiwan	738688-AB1
	For use in Thailand	738688-281
	For use in Turkey	738688-141
	For use in the United Kingdom and Singapore	738688-031
	For use in the United States	738688-001
	Keyboard for 14" models (includes keyboard cable):	
	For use in Belgium	738687-A41
	For use in Bulgaria	738687-261
	For use in Canada	738687-DB1
	For use in the Czech Republic and Slovakia	738687-FL1
	For use in Denmark	738687-081
	For use in France	738687-051
	For use in Germany	738687-041
	For use in Greece	738687-151
	For use in Hungary	738687-211
	For use in Iceland	738687-DD1
	For use in India	738687-D61
	For use in Israel	738687-BB1
	For use in Italy	738687-061
	For use in Japan	738687-291
	For use in Latin America	738687-161
	For use in the Netherlands	738687-B31
	For use in Northwest Africa	738687-FP1
	For use in Norway	738687-091
	For use in Portugal	738687-131
	For use in Romania	738687-271
	For use in Russia	738687-251
	For use in Saudi Arabia	738687-171
	For use in Slovenia	738687-BA1
	For use in South Korea	738687-AD1
	For use in Spain	738687-071

Item	Component	Spare part number
	For use in Sweden and Finland	738687-B71
	For use in Switzerland	738687-BG1
	For use in Taiwan	738687-AB1
	For use in Thailand	738687-281
	For use in Turkey	738687-141
	For use in the United Kingdom and Singapore	738687-031
	For use in the United States	738687-001
(4)	Power connector board	
(5)	Top cover (includes TouchPad, TouchPad cable, and TouchPad bracket)	734281-001
(6)	Smart card reader (includes cable)	
	2-button TouchPad	738398-001
	4-button TouchPad	744005-001
(7)	Power button board (includes cable)	
	For 15.6-in models	738701-001
	For 14-in models	738399-001
(8)	Speakers (include cable)	738404-001
(9)	Wireless card	
(10)	Smart card reader shield (select models only) (included with smart card reader)	
(11)	Fingerprint reader bracket (included with fingerprint reader)	
(12)	Fingerprint reader board (includes cable and double-sided adhesive)	738394-001
(13)	TouchPad (includes bracket)	
	For 15.6-in models with 2-button TouchPad	738710-001
	For 15.6-in models with 4-button TouchPad	738711-001
	For 14-in models with 2-button TouchPad	738405-001
	For 14-in models with 4-button TouchPad	738406-001
(14)	Function button board (includes cable and double-sided adhesive)	738703-001 738401-001
(15)	Processor (includes replacement thermal material):	
	Intel Dual Core i7-4600M 2.80-GHz processor (4.0-MB L3 cache, 37 W)	737330-001
	Intel Dual Core i5-4330M 2.80-GHz processor (3.0-MB L3 cache, 37 W)	738201-001
	Intel Dual Core i5-4300M 2.60-GHz processor (3.0-MB L3 cache, 37 W)	738309-001
	Intel Dual Core i5-4200M 2.50-GHz processor (3.0-MB L3 cache, 37 W)	737328-001
	Intel Dual Core i3-4100M 2.50-GHz processor (3.0-MB L3 cache, 37 W)	737474-001
	Intel Dual Core i3-4000M 2.40-GHz processor (3.0-MB L3 cache, 37 W)	737327-001

Item	Component	Spare part number
	AMD A10-5750M with Radeon HD 8650G Graphics (quad-core; 3.5 GHz/2.5 GHz; 35W, 4 MB L2 cache)	713548-001
	AMD A10-4600M with Radeon HD 7660G Graphics (quad-core; 3.2 GHz/2.3 GHz; 35W; 4 MB L2 cache)	683046-001
	AMD A8-4500M with Radeon HD 7640G Graphics (quad-core; 2.8 GHz/1.9 GHz; 35W; 4 MB L2 cache)	683048-001
	AMD A6-4400M with Radeon HD 7520G Graphics (dual-core; 3.2 GHz/2.7 GHz; 35W; 1 MB L2 cache)	683047-001
	AMD A6-5350M with Radeon HD 8450G Graphics (dual-core; 3.5 GHz/2.9 GHz; 35W; 1 MB L2 cache)	713550-001
	AMD A4-4300M with Radeon HD 7420G Graphics (dual-core; 3.0 GHz/2.5 GHz; 35W; 1 MB L2 cache)	685990-001
	AMD A4-5150M with Radeon HD 8350G Graphics (dual-core; 3.3 GHz/2.7 GHz; 35W; 1 MB L2 cache)	713549-001
	AMD A8-5550M Quad Core 3.1 GHz/2.1 GHz	713551-001
(16)	Audio/USB board (includes SD Card reader)	738400-001 745891-001
(17)	System board (includes battery connector bracket and replacement thermal material):	
	System board for 14-in. computer models equipped with shared memory and the Windows 8 Standard operating system with WWAN capability (includes replacement thermal material)	744007-001
	System board for 14-in. computer models equipped with shared memory and the Windows 8 Standard operating system with WWAN capability (includes replacement thermal material)	744007-501
	System board for 14-in. computer models equipped with shared memory and the Windows 8 Professional operating system with WWAN capability (includes replacement thermal material)	744007-601
	System board for 14-in. computer models equipped with discrete memory and WWAN capability (includes replacement thermal material)	744008-001
	System board for 14-in. computer models equipped with discrete memory and the Windows 8 Standard operating system with WWAN capability (includes replacement thermal material)	744008-501
	System board for 14-in. computer models equipped with discrete memory and the Windows 8 Professional operating system with WWAN capability (includes replacement thermal material)	744008-601
	System board for 14-in. computer models equipped with discrete memory, WWAN capability (includes replacement thermal material)	744009-001
	System board for 14-in. computer models equipped with discrete memory and the Windows 8 Standard operating system with WWAN capability (includes replacement thermal material)	744009-501
	System board for 14-in. computer models equipped with shared memory and the Windows 8 Professional operating system with WWAN capability (includes replacement thermal material)	744009-601
	System board for 14-in. computer models equipped with discrete memory and WWAN capability (includes replacement thermal material)	744010-001

Item	Component	Spare part number
	System board for 14-in. computer models equipped with discrete memory and the Windows 8 Standard operating system with WWAN capability (includes replacement thermal material)	744010-501
	System board for 14-in. computer models equipped with shared memory and the Windows 8 Professional operating system with WWAN capability (includes replacement thermal material)	744010-601
	System board for 15.6-in. computer models equipped with discrete memory, WWAN capability (includes replacement thermal material)	744015-001
	System board for 15.6-in. computer models equipped with discrete memory and the Windows 8 Standard operating system with WWAN capability (includes replacement thermal material)	744015-501
	System board for 15.6-in. computer models equipped with shared memory and the Windows 8 Professional operating system with WWAN capability (includes replacement thermal material)	744015-601
	System board for 15.6-in. computer models equipped with shared memory with WWAN capability (includes replacement thermal material)	744015-001
	System board for 15.6-in. computer models equipped with shared memory and the Windows 8 Standard operating system with WWAN capability (includes replacement thermal material)	744015-501
	System board for 15.6-in. computer models equipped with shared memory and the Windows 8 Professional operating system with WWAN capability (includes replacement thermal material)	744015-601
	System board for 15.6-in. computer models equipped with shared memory, WWAN capability, and a modem (includes replacement thermal material)	744016-001
	System board for 15.6-in. computer models equipped with shared memory and the Windows 8 Standard operating system with WWAN capability and a modem (includes replacement thermal material)	744016-501
	System board for 15.6-in. computer models equipped with shared memory and the Windows 8 Professional operating system with WWAN capability and a modem (includes replacement thermal material)	744016-601
	System board for 15.6-in. computer models equipped with discrete memory with WWAN capability (includes replacement thermal material)	744017-001
	System board for 15.6-in. computer models equipped with discrete memory and the Windows 8 Standard operating system with WWAN capability (includes replacement thermal material)	744017-501
	System board for 15.6-in. computer models equipped with discrete memory and the Windows 8 Professional operating system with WWAN capability (includes replacement thermal material)	744017-601
	System board for 15.6-in. computer models equipped with discrete memory with WWAN capability and a modem (includes replacement thermal material)	744018-001
	System board for 15.6-in. computer models equipped with discrete memory and the Windows 8 Standard operating system with WWAN capability and a modem (includes replacement thermal material)	744018-501
	System board for 15.6-in. computer models equipped with discrete memory and the Windows 8 Professional operating system with WWAN capability and a modem (includes replacement thermal material)	744018-601
	System board for 15.6-in. computer models equipped with shared memory, WWAN capability (includes replacement thermal material)	744019-001

Item	Component	Spare part number
	System board for 15.6-in. computer models equipped with shared memory and the Windows 8 Standard operating system with WWAN capability (includes replacement thermal material)	744019-501
	System board for 15.6-in. computer models equipped with shared memory and the Windows 8 Professional operating system with WWAN capability (includes replacement thermal material)	744019-601
	System board for 15.6-in. computer models equipped with shared memory, WWAN capability and a modem (includes replacement thermal material)	744020-001
	System board for 15.6-in. computer models equipped with shared memory and the Windows 8 Standard operating system with WWAN capability and a modem (includes replacement thermal material)	744020-501
	System board for 15.6-in. computer models equipped with shared memory and the Windows 8 Professional operating system with WWAN capability and a modem (includes replacement thermal material)	744020-601
	System board for 15.6-in. computer models equipped with discrete memory, WWAN capability (includes replacement thermal material)	744021-001
	System board for 15.6-in. computer models equipped with discrete memory and the Windows 8 Standard operating system with WWAN capability (includes replacement thermal material)	744021-501
	System board for 15.6-in. computer models equipped with discrete memory and the Windows 8 Professional operating system with WWAN capability (includes replacement thermal material)	744021-601
	System board for 15.6-in. computer models equipped with discrete memory, WWAN capability and a modem (includes replacement thermal material)	744022-001
	System board for 15.6-in. computer models equipped with discrete memory and the Windows 8 Standard operating system with WWAN capability and a modem (includes replacement thermal material)	744022-501
	System board for 15.6-in. computer models equipped with discrete memory and the Windows 8 Professional operating system with WWAN capability and a modem (includes replacement thermal material)	744022-601
	For use only 14-in. computer models equipped with an Intel Quad Core processor with WWAN capability	745883-001
	For use only on 14-in. computer models equipped with shared memory and the Windows 8 Standard operating system with WWAN capability	745883-501
	For use only on 14-in. computer models equipped with shared memory and the Windows 8 Professional operating system with WWAN capability	745883-601
	For use only 14-in. computer models equipped with shared memory without WWAN capability	745884-001
	For use only on 14-in. computer models equipped with shared memory and the Windows 8 Standard operating system without WWAN capability	745884-501
	For use only on 14-in. computer models equipped with shared memory, the Windows 8 Professional operating system without WWAN capability	745884-601
	For use only on 15.6-in. computer models equipped with shared memory and WWAN capability	745887-001
	For use only on 15.6-in. computer models equipped with shared memory and the Windows 8 Standard operating system and WWAN capability	745887-501

Item	Component	Spare part number
	For use only on 15.6-in. computer models equipped with shared memory and the Windows 8 Professional operating system with WWAN capability	745887-601
	For use only on 15.6-in computer models equipped with shared memory without WWAN capability	745888-001
	For use only on 15.6-in computer models equipped with shared memory and the Windows 8 Standard operating system without WWAN capability	745888-501
	For use only on 15.6-in computer models equipped with shared memory and the Windows 8 Professional operating system without WWAN capability	745888-601
(18)	Optical drive (includes bezel and bracket):	
	Blu-ray R/RE DVD±RW SuperMulti Double-Layer Combo Drive	749959-001 739999-001 744820-001
	DVD±RW SuperMulti Double-Layer Drive	749958-001 744822-001 740001-001
	DVD-ROM Drive	749957-001 744821-001 740000-001 735601-001
	Fan and heat sink assembly (includes replacement thermal material):	
(19)	Fan	738685-001
(20)	Heat sink for computer models with shared graphics	738686-001
(22)	Heat sink for computer models with discrete graphics	738393-001
(21)	Fingerprint reader bracket	738394
(23)	Base enclosure (includes 4 rubber feet, battery lock latch, battery release latch, and RJ-45 cover)	
	For 14-in models	738681-001
	For 15.6-in models	738692-001
(24)	Power connector cable	738694-001
(25)	Modem (select models only)	628824-001
(26)	WLAN module:	
	Intel 802.11 2x2 a/b/g/n	695915-001
	Intel 802.11 2x2 a/b/g/n Combo Adapter	670292-001
	Atheros 802.11 b/g/n 1x1	690019-001
	Intel 802.11 2x2 AC + Bluetooth 4.0	710661-001
	Intel 802.11 2x2 AC + Bluetooth 4.0	717381-001
	Intel 802.11 a/b/g/n 2x2 + Bluetooth 4.0 WLAN	710661-001

Item	Component	Spare part number
	Broadcom 802.11 a/b/g/n 2x2 + BT 4.0 LE PCIe+USB HMC WW	730668-001
	Intel 802.11 a/b/g/n 2x2 + BT 4.0 WLAN	747832-001
(27)	Solid-state drive	
	512-GB SATA-3 SSD	738714-001
	256-GB SATA-3 self-encrypting SSD	735598-001
	180-GB SATA-3 SSD	735597-001
	128-GB SATA-3 SSD	735596-001
	128-GB mSATA-3 SSD	735595-001
	32-GB mSATA flash cache SSD	735594-001
(28)	Hard drive (does not include hard drive bracket or screws):	
	1-TB, 5400-rpm, 9.5-mm	676521-001
	750-GB, 7200-rpm, 7.0-mm	633252-001
	500-GB, 7200-rpm, 7.0-mm	703267-001
	500-GB, 5400-rpm, 7.0-mm, FIPS	730946-001
	500-GB, 7200-rpm, 7.0-mm, self-encrypting	703268-001
	320-GB, 7200-rpm, 7.0-mm	634862-001
	Hard Drive Hardware Kit (not illustrated, includes hard drive bracket and screws)	738395-001
(29)	WWAN module (select models only)	
	HP hs3110 HSPA+ Mobile Broadband Module	723895-001
	HP lt4111 LTE/EV-DO/HSPA+ Mobile Broadband Module	704030-001
	HP lt4112 LTE/HSPA+ Mobile Broadband Module	704031-001
(30)	Battery:	
	9-cell, 100-WHr, 3.0-AHr, Li-ion battery	718757-001
	6-cell, 55-WHr, 2.8-AHr, Li-ion battery	718756-001
	6-cell, 55-WHr, 2.5-AHr, Li-ion battery	708455-001
	3-cell, 33-WHr, 2.0-AHr, Li-ion battery	718754-001
(31)	Service cover	
	For 15.6-in models	738691-001
	For 14-in models	738680-001

Display assembly subcomponents

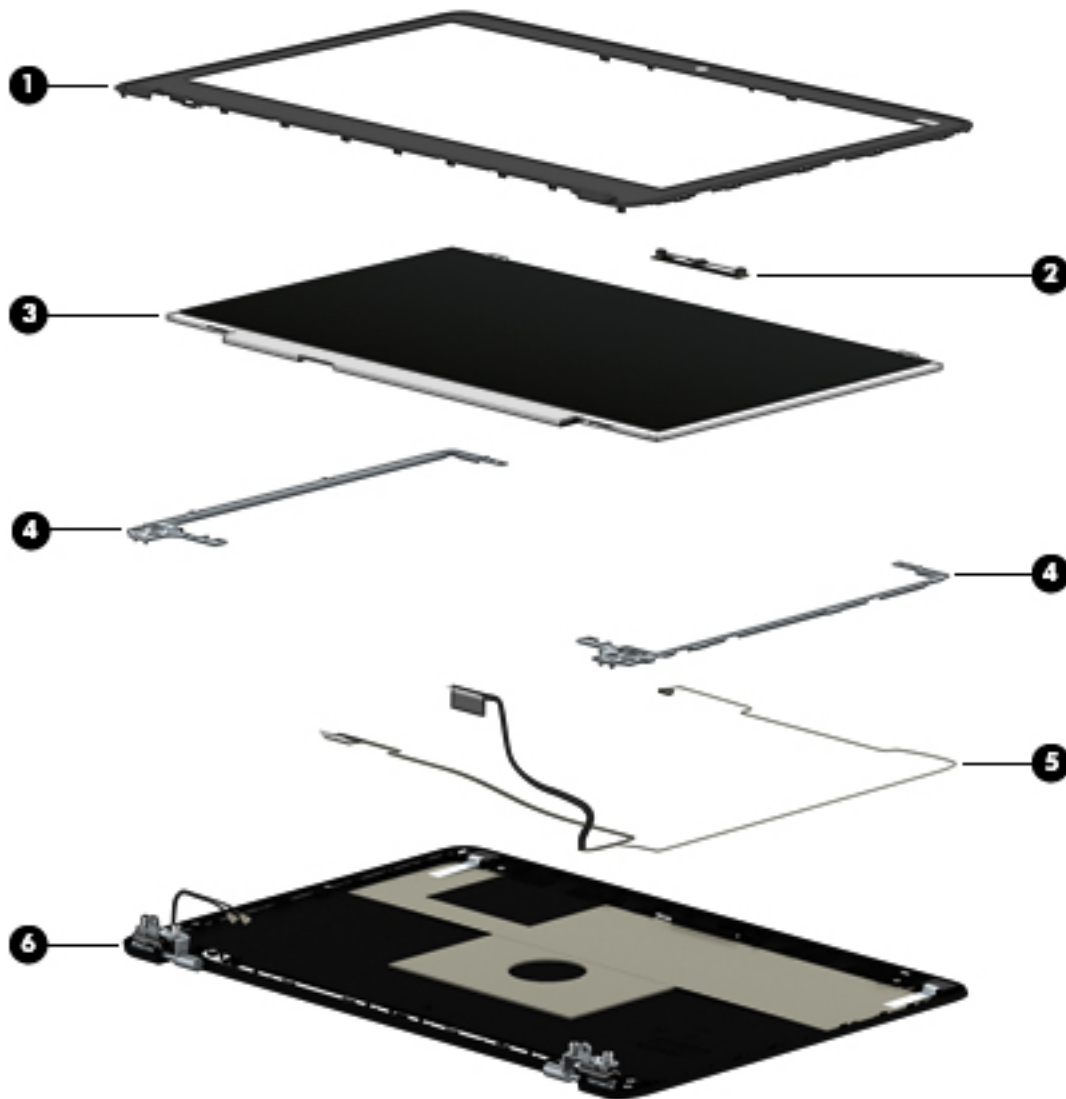

Item	Component	Spare part number
(1)	Display bezel:	
	For use only on 15.6-in computer models	738690-001
	For use only on 14-in computer models	738679-001
(2)	Webcamera/microphone module (includes double-sided adhesive)	738409-001
	Microphone module (includes double-sided adhesive)	738397-001
(3)	Display panel:	
	15.6-in WLED FHD, UWVA, display panel	739998-001
	15.6-in WLED HD, SVA, display panel	739997-001
	14-in WLED FHD, UWVA, display panel	747753-001

Item	Component	Spare part number
	14-in WLED HD, SVA, display panel	747752-001
	14-in WLED HD, SVA, display panel	747751-001
(4) and (6)	Display hinge kit (includes left and right hinges and display panel cable bracket)	
	For 15.6-in computer models	738699-001
	For 14-in computer models	738396-001
(5)	Display Panel Support Kit (includes display enclosure, display panel cable, and wireless antenna cables and transceivers)	
	For 15.6-in computer models	738695-001
	For 14-in computer models	738684-001

Cables

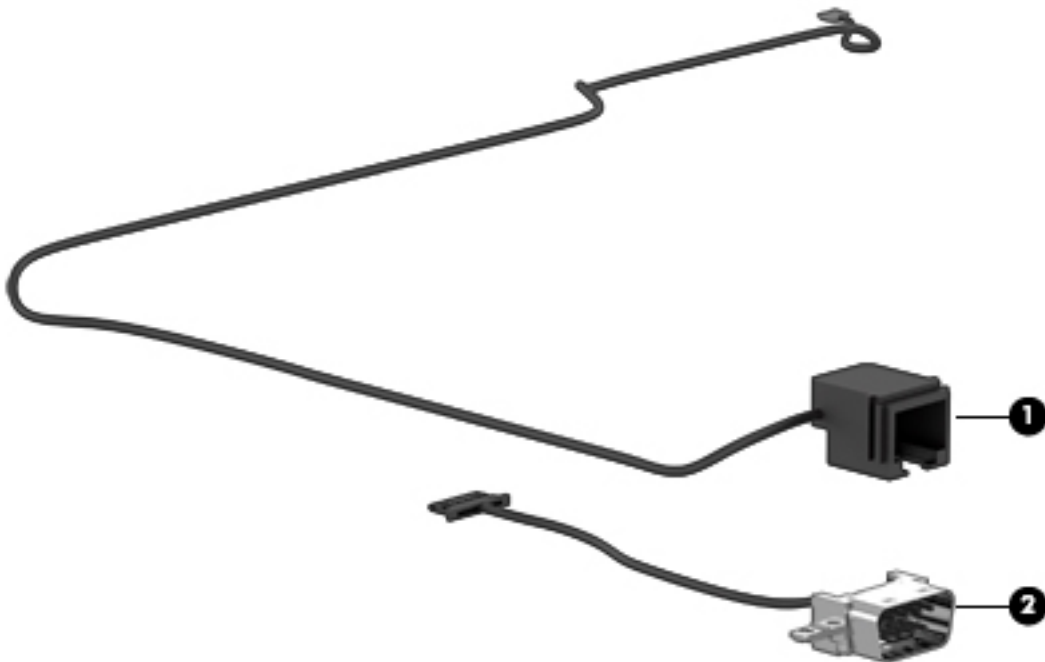

Item	Component	Spare part number
(1)	RJ-45 (network) cable	744013-001
(2)	Display cable kit	
	For 14-in models	738684-001
	For 15.6-in models	738695

Plastics Kit



Item	Component	Spare part number
	Plastics Kit, includes:	
	For 14-in models	738402-001
	For 15.6-in models	738706-001
(1)	Fingerprint bracket	
(2)	Smart card reader blank	
(3)	WLAN bracket	
(4)	Fingerprint reader bezel	
(5)	SD card reader bezel	
(6)	Optical drive blank tray	

Mass storage devices



Item	Component	Spare part number
(1)	Solid-state drive (SSD):	
	256-GB SATA-3 self-encrypting SSD	749263-001
	180-GB SATA-3 SSD	749262-001
		749278-001
	128-GB SATA-3 SSD	749261-001
		749277-001
	128-GB mSATA-3 SSD	749280-0011
	32-GB mSATA flash cache SSD	7749281-001
	Hard Drive Hardware Kit, includes:	738395-001
(2)	Hard drive bracket	
	Screws (not illustrated)	
(3)	Hard drive (does not include hard drive bracket or screws):	
	1-TB, 5400-rpm, 9.5-mm	676521-001
	750-GB, 7200-rpm, 7.0-mm	633252-001
	500-GB, 7200-rpm, 7.0-mm	703267-001
	500-GB, 5400-rpm, 7.0-mm, FIPS	730946-001

Item	Component	Spare part number
	500-GB, 7200-rpm, 7.0-mm, self-encrypting	703268-001
	320-GB, 7200-rpm, 7.0-mm	634862-001
(4)	Optical drive (includes bezel and bracket):	
	Blu-ray R/RE DVD±RW SuperMulti Double-Layer Combo Drive	749959-001
		739999-001
		744820-001
	DVD±RW SuperMulti Double-Layer Drive	749958-001
		744822-001
		740000-001
	DVD-ROM Drive	749957-001
		744821-001
		740001-001
		735601-001

Miscellaneous parts

Component	Spare part number
AC adapter:	
65-W HP Smart adapter (PFC, 3-wire, 4.5-mm)	693710-001
65-W HP Smart adapter (PFC, 3-wire, 4.5-mm)	693711-001
90-W HP Smart adapter (PFC, 3-wire, 4.5-mm)	693712-001
90-W HP Smart adapter (PFC, 3-wire, 4.5-mm)	693713-001
Power cord (3-pin, black, 1.83-m):	
For use in Argentina	490371-D01
For use in Australia	490371-011
For use in Brazil	490371-202
For use in Europe	490371-021
For use in India	490371-D61
For use in Israel	490371-BB1
For use in Italy	490371-061
For use in Japan	490371-291
For use in North America	490371-001
For use in the People's Republic of China	490371-AA1
For use in South Africa	490371-AR1
For use in South Korea	490371-AD1

Component	Spare part number
For use in Switzerland	490371-111
For use in Taiwan	490371-AB1
For use in Thailand	490371-201
For use in the United Kingdom and Singapore	490371-031
Screw Kit	738689-001

Sequential part number listing

Spare part number	Description
490371-001	Power cord for use in North America (3-pin, black, 1.83-m)
490371-011	Power cord for use in Australia (3-pin, black, 1.83-m)
490371-021	Power cord for use in Europe (3-pin, black, 1.83-m)
490371-031	Power cord for use in the United Kingdom and Singapore (3-pin, black, 1.83-m)
490371-061	Power cord for use in Italy (3-pin, black, 1.83-m)
490371-111	Power cord for use in Switzerland (3-pin, black, 1.83-m)
490371-201	Power cord for use in Thailand (3-pin, black, 1.83-m)
490371-202	Power cord for use in Brazil (3-pin, black, 1.83-m)
490371-291	Power cord for use in Japan (3-pin, black, 1.83-m)
490371-AA1	Power cord for use in the People's Republic of China (3-pin, black, 1.83-m)
490371-AB1	Power cord for use in Taiwan (3-pin, black, 1.83-m)
490371-AD1	Power cord for use in South Korea (3-pin, black, 1.83-m)
490371-AR1	Power cord for use in South Africa (3-pin, black, 1.83-m)
490371-BB1	Power cord for use in Israel (3-pin, black, 1.83-m)
490371-D01	Power cord for use in Argentina (3-pin, black, 1.83-m)
490371-D61	Power cord for use in India (3-pin, black, 1.83-m)
603783-001	320-GB, 7200-rpm, SATA, 7.0-mm hard drive (does not include hard drive bracket or screws) NOTE: The hard drive bracket and screws are included in the Hard Drive Hardware Kit, spare part number 738395-001.
628824-001	Modem (select models only)
633252-001	750-GB, 7200-rpm, SATA, 2.5-in hard drive (does not include hard drive bracket or screws) NOTE: The hard drive bracket and screws are included in the Hard Drive Hardware Kit, spare part number 738395-001.
634862-001	320-GB, 7200-rpm, SATA, 7.0-mm hard drive (does not include hard drive bracket or screws) NOTE: The hard drive bracket and screws are included in the Hard Drive Hardware Kit, spare part number 738395-001.

Spare part number	Description
634921-001	500GB, 7200-rpm, SATA, 2.5-in hard drive (does not include hard drive bracket or screws) NOTE: The hard drive bracket and screws are included in the Hard Drive Hardware Kit, spare part number 738395-001.
634925-001	500GB, 7200-rpm, SATA, 2.5-in hard drive (does not include hard drive bracket or screws) NOTE: The hard drive bracket and screws are included in the Hard Drive Hardware Kit, spare part number 738395-001.
651948-001	RTC battery (includes cable and double-sided adhesive)
670292-001	Intel 802.11 a/b/g/n 2x2 Combo Adapter
675794-001	Intel 802.11 b/g/n HMC 1x1
676521-001	1-TB, 5400-rpm, SATA, 9.5-mm hard drive (does not include hard drive bracket or screws) NOTE: The hard drive bracket and screws are included in the Hard Drive Hardware Kit, spare part number 738395-001.
683046-001	AMD A10-4600M with Radeon HD 7660G Graphics (quad-core; 3.2 GHz/2.3 GHz; 35W; 4 MB L2 cache)
683047-001	AMD A6-4400M with Radeon HD 7520G Graphics (dual-core; 3.2 GHz/2.7 GHz; 35W; 1 MB L2 cache)
683048-001	AMD A8-4500M with Radeon HD 7640G Graphics (quad-core; 2.8 GHz/1.9 GHz; 35W; 4 MB L2 cache)
683801-001	500-GBB, 7200-rpm, SATA, self-encrypting hard drive 9.5-mm hard drive (does not include hard drive bracket or screws) NOTE: The hard drive bracket and screws are included in the Hard Drive Hardware Kit, spare part number 738395-001.
683802-001	500-GBB, 5400-rpm, SATA, hard drive 7-mm hard drive (does not include hard drive bracket or screws) NOTE: The hard drive bracket and screws are included in the Hard Drive Hardware Kit, spare part number 738395-001.
685990-001	Processor A4-4300M 3.0/2.5 GHz 35W 1M
685990-001	750-GBB, 7200-rpm, SATA hard drive 2.5-in hard drive (does not include hard drive bracket or screws) NOTE: The hard drive bracket and screws are included in the Hard Drive Hardware Kit, spare part number 738395-001.
686850-001	750-GBB, 7200-rpm, SATA hard drive 2.5-in hard drive (does not include hard drive bracket or screws) NOTE: The hard drive bracket and screws are included in the Hard Drive Hardware Kit, spare part number 738395-001.
688169-001	Dock/expansion base (select models only)
690019-001	Atheros 802.11 b/g/n 1x1
691739-001	2-GB memory module (PC3L, 12800, 1600-MHz)
691740-001	4-GB memory module (PC3L, 12800, 1600-MHz)
691922-001	HP comfort grip wireless mouse
693374-001	8-GB memory module (PC3L, 12800, 1600-MHz)

Spare part number	Description
693710-001	65-W HP Smart adapter (PFC, 3-wire, 4.5-mm)
693711-001	65-W HP Smart adapter (PFC, 3-wire, 4.5-mm)
693712-001	90-W HP Smart adapter (PFC, 3-wire, 4.5-mm)
693713-001	90-W HP Smart adapter (PFC, 3-wire, 4.5-mm)
695915-001	Intel 802.11 2x2 a/b/g/n
703267-001	500-GB, 7200-rpm, SATA, 7.0-mm hard drive (does not include hard drive bracket or screws) NOTE: The hard drive bracket and screws are included in the Hard Drive Hardware Kit, spare part number 738395-001.
703268-001	500-GB, 7200-rpm, SATA, 7.0-mm self-encrypting drive (SED, does not include hard drive bracket or screws) NOTE: The hard drive bracket and screws are included in the Hard Drive Hardware Kit, spare part number 738395-001.
704030-001	HP It4111 LTE/EV-DO/HSPA+ Mobile Broadband Module
704031-001	HP It4112 LTE/HSPA+ Mobile Broadband Module
710661-001	Intel 802.11 2x2 AC + Bluetooth 4.0
713548-001	AMD A10-5750M with Radeon HD 8650G Graphics (quad-core; 3.5 GHz/2.5 GHz; 35W, 4 MB L2 cache)
713549-001	AMD A4-5150M with Radeon HD 8350G Graphics (dual-core; 3.3 GHz/2.7 GHz; 35W; 1 MB L2 cache)
713550-001	A6-5350M with Radeon HD 8450G Graphics (dual-core; 3.5 GHz/2.9 GHz; 35W; 1 MB L2 cache)
713551-001	AMD A8-5550M Quad Core 3.1 GHz/2.1 GHz HD8550G
717381-001	Intel 802.11 a/b/g/n 2x2 + Bluetooth 4.0 WLAN
718754-001	3-cell, 33-WHr, 2.0-AHr, Li-ion battery
718755-001	6-cell, 55-WHr, 2.55-AHr, Li-ion battery
718756-001	6-cell, 55-WHr, 2.8-AHr, Li-ion battery
718757-001	9-cell, 100-WHr, 3.0-AHr, Li-ion battery
723895-001	HP hs3110 HSPA+ Mobile Broadband Module
730668-001	Broadcom 802.11 a/b/g/n 2x2 + BT 4.0 LE PCIe+USB HMC WW
730946-001	500-GB, 5400-rpm, SATA, 7.0-mm FIPS hard drive (does not include hard drive bracket or screws) NOTE: The hard drive bracket and screws are included in the Hard Drive Hardware Kit, spare part number 738395-001.
735400-001	USB board (includes cable and double-sided adhesive)
735401-001	Function button board (includes cable and double-sided adhesive)
735402-001	Plastics kit
735404-001	Speaker kit
735405-001	Top cover and 2-button TouchPad for 14-in models
735406-001	Top cover and 4-button TouchPad for 14-in models

Spare part number	Description
735407-001	TouchPad bracket with 2 buttons
735408-001	TouchPad bracket with 4 buttons
735409-001	Webcamera/microphone module (includes double-sided adhesive)
737327-001	Intel Dual Core i3-4000M 2.40-GHz processor (3.0- MB L3 cache, 37 W)
737328-001	Intel Dual Core i5-4200M 2.50-GHz processor (3.0- MB L3 cache, 37 W)
737330-001	Intel Dual Core i7 4600M 2.8 GHz (3MB 37W)
737474-001	Intel Dual Core i3-4100M 2.50-GHz processor (3.0- MB L3 cache, 37 W)
738201-001	Intel Dual Core i5-4330M 2.80-GHz processor (3.0- MB L3 cache, 37 W)
738309-001	Intel Dual Core i5-4300M 2.60-GHz processor (3.0-MB L3 cache, 37 W)
738393-001	Heat sink assembly for models with discrete memory
738394-001	Fingerprint reader (includes cable)
738395-001	Hard drive hardware kit
738396-001	Display hinge kit
738397-001	Microphone module (includes double-sided adhesive)
738398-001	Smart card reader for 14-in models with 2-button TouchPad (includes cable)
738399-001	Power button board (includes cable)
738403-001	Rubber kit
738679-001	Display bezel for 14-in models
738680-001	Display Panel Support Kit for 14-in models
738681-001	Base enclosure for 14-in models
738682-001	Service cover for 14-in models
738683-001	Power cable for 14-in models
738684-001	Display cable kit for 14-in models
738685-001	Fan
738686-001	Heat sink assembly for use only with models with shared memory
738687-001	Keyboard for 14-in models for use in the United States (includes keyboard cable)
738687-031	Keyboard for 14-in models for use in the United Kingdom and Singapore (includes keyboard cable)
738687-041	Keyboard for 14-in models for use in Germany (includes keyboard cable)
738687-051	Keyboard for 14-in models for use in France (includes keyboard cable)
738687-061	Keyboard for 14-in models for use in Italy (includes keyboard cable)
738687-071	Keyboard for 14-in models for use in Spain (includes keyboard cable)
738687-081	Keyboard for 14-in models for use in Denmark (includes keyboard cable)
738687-091	Keyboard for 14-in models for use in Norway (includes keyboard cable)
738687-131	Keyboard for 14-in models for use in Portugal (includes keyboard cable)

Spare part number	Description
738687-141	Keyboard for 14-in models for use in Turkey (includes keyboard cable)
738687-151	Keyboard for 14-in models for use in Greece (includes keyboard cable)
738687-161	Keyboard for 14-in models for use in Latin America (includes keyboard cable)
738687-171	Keyboard for 14-in models for use in Saudi Arabia (includes keyboard cable)
738687-211	Keyboard for 14-in models for use in Hungary (includes keyboard cable)
738687-251	Keyboard for 14-in models for use in Russia (includes keyboard cable)
738687-261	Keyboard for 14-in models for use in Bulgaria (includes keyboard cable)
738687-271	Keyboard for 14-in models for use in Romania (includes keyboard cable)
738687-281	Keyboard for 14-in models for use in Thailand (includes keyboard cable)
738687-291	Keyboard for 14-in models for use in Japan (includes keyboard cable)
738687-A41	Keyboard for 14-in models for use in Belgium (includes keyboard cable)
738687-AB1	Keyboard for 14-in models for use in Taiwan (includes keyboard cable)
738687-AD1	Keyboard for 14-in models for use in South Korea (includes keyboard cable)
738687-B31	Keyboard for 14-in models for use in the Netherlands (includes keyboard cable)
738687-B71	Keyboard for 14-in models for use in Sweden (includes keyboard cable)
738687-BA1	Keyboard for 14-in models for use in Slovenia (includes keyboard cable)
738687-BB1	Keyboard for 14-in models for use in Israel (includes keyboard cable)
738687-BG1	Keyboard for 14-in models for use in Switzerland (includes keyboard cable)
738687-D61	Keyboard for 14-in models for use in India (includes keyboard cable)
738687-DB1	Keyboard for 14-in models for use in Canada (includes keyboard cable)
738687-DD1	Keyboard for 14-in models for use in Iceland (includes keyboard cable)
738687-FL1	Keyboard for 14-in models for use in the Czech Republic and Slovakia (includes keyboard cable)
738687-FP1	Keyboard for 14-in models for use in Northwest Africa (includes keyboard cable)
738688-001	Keyboard with pointing stick for 14-in models for use in the United States (includes keyboard cable and pointing stick cable)
738688-031	Keyboard with pointing stick for 14-in models for use in the United Kingdom and Singapore (includes keyboard cable and pointing stick cable)
738688-041	Keyboard with pointing stick for 14-in models for use in Germany (includes keyboard cable and pointing stick cable)
738688-051	Keyboard with pointing stick for 14-in models for use in France (includes keyboard cable and pointing stick cable)
738688-061	Keyboard with pointing stick for 14-in models for use in Italy (includes keyboard cable and pointing stick cable)
738688-071	Keyboard with pointing stick for 14-in models for use in Spain (includes keyboard cable and pointing stick cable)
738688-081	Keyboard with pointing stick for 14-in models for use in Denmark (includes keyboard cable and pointing stick cable)

Spare part number	Description
738688-091	Keyboard with pointing stick for 14-in models for use in Norway (includes keyboard cable and pointing stick cable)
738688-131	Keyboard with pointing stick for 14-in models for use in Portugal (includes keyboard cable and pointing stick cable)
738688-141	Keyboard with pointing stick for 14-in models for use in Turkey (includes keyboard cable and pointing stick cable)
738688-151	Keyboard with pointing stick for 14-in models for use in Greece (includes keyboard cable and pointing stick cable)
738688-161	Keyboard with pointing stick for 14-in models for use in Latin America (includes keyboard cable and pointing stick cable)
738688-171	Keyboard with pointing stick for 14-in models for use in Saudi Arabia (includes keyboard cable and pointing stick cable)
738688-201	Keyboard with pointing stick for 14-in models for use in Brazil (includes keyboard cable and pointing stick cable)
738688-211	Keyboard with pointing stick for 14-in models for use in Hungary (includes keyboard cable and pointing stick cable)
738688-251	Keyboard with pointing stick for 14-in models for use in Russia (includes keyboard cable and pointing stick cable)
738688-261	Keyboard with pointing stick for 14-in models for use in Bulgaria (includes keyboard cable and pointing stick cable)
738688-271	Keyboard with pointing stick for 14-in models for use in Romania (includes keyboard cable and pointing stick cable)
738688-281	Keyboard with pointing stick for 14-in models for use in Thailand (includes keyboard cable and pointing stick cable)
738688-291	Keyboard with pointing stick for 14-in models for use in Japan (includes keyboard cable and pointing stick cable)
738688-A41	Keyboard with pointing stick for 14-in models for use in Belgium (includes keyboard cable and pointing stick cable)
738688-AB1	Keyboard with pointing stick for 14-in models for use in Taiwan (includes keyboard cable and pointing stick cable)
738688-AD1	Keyboard with pointing stick for 14-in models for use in South Korea (includes keyboard cable and pointing stick cable)
738688-B31	Keyboard with pointing stick for 14-in models for use in the Netherlands (includes keyboard cable and pointing stick cable)
738688-B71	Keyboard with pointing stick for 14-in models for use in Sweden and Finland (includes keyboard cable and pointing stick cable)
738688-BA1	Keyboard with pointing stick for 14-in models for use in Slovenia (includes keyboard cable and pointing stick cable)
738688-BB1	Keyboard with pointing stick for 14-in models for use in Israel (includes keyboard cable and pointing stick cable)
738688-BG1	Keyboard with pointing stick for 14-in models for use in Switzerland (includes keyboard cable and pointing stick cable)
738688-D61	Keyboard with pointing stick for 14-in models for use in India (includes keyboard cable and pointing stick cable)

Spare part number	Description
738688-DB1	Keyboard with pointing stick for 14-in models for use in Canada (includes keyboard cable and pointing stick cable)
738688-DD1	Keyboard with pointing stick for 14-in models for use in Iceland includes keyboard cable and pointing stick cable)
738688-FL1	Keyboard with pointing stick for 14-in models for use in the Czech Republic and Serbia (includes keyboard cable and pointing stick cable)
738688-FP1	Keyboard with pointing stick for 14-in models for use in Northwest Africa (includes keyboard cable and pointing stick cable)
738689-001	Screw Kit
738690-001	Display bezel for 15.6-in models
738691-001	Display Panel Support Kit for 15.6-in models
738692-001	Base enclosure for 15.6-in models
738693-001	Service cover for 15.6-in models
738694-001	Power cable for 15.6-in models
738695-001	Display cable kit for 15.6-in models
738696-001	Keyboard for 15.6-in models for use in the United States (includes keyboard cable)
738696-031	Keyboard for 15.6-in models for use in the United Kingdom and Singapore (includes keyboard cable)
738696-041	Keyboard for 15.6-in models for use in Germany (includes keyboard cable)
738696-051	Keyboard for 15.6-in models for use in France (includes keyboard cable)
738696-061	Keyboard for 15.6-in models for use in Italy (includes keyboard cable)
738696-071	Keyboard for 15.6-in models for use in Spain (includes keyboard cable)
738696-081	Keyboard for 15.6-in models for use in Denmark (includes keyboard cable)
738696-091	Keyboard for 15.6-in models for use in Norway (includes keyboard cable, backlight cable, and pointing stick cable)
738696-131	Keyboard for 15.6-in models for use in Portugal (includes keyboard cable)
738696-141	Keyboard for 15.6-in models for use in Turkey (includes keyboard cable)
738696-151	Keyboard for 15.6-in models for use in Greece (includes keyboard cable, backlight cable, and pointing stick cable)
738696-161	Keyboard for 15.6-in models for use in Latin America (includes keyboard cable)
738696-171	Keyboard for 15.6-in models for use in Saudi Arabia (includes keyboard cable)
738696-201	Keyboard for 15.6-in models for use in Brazil (includes keyboard cable)
738696-211	Keyboard for 15.6-in models for use in Hungary (includes keyboard cable, backlight cable, and pointing stick cable)
738696-251	Keyboard for 15.6-in models for use in Russia (includes keyboard cable)
738696-261	Keyboard for 15.6-in models for use in Bulgaria (includes keyboard cable)
738696-271	Keyboard for 15.6-in models for use in Romania (includes keyboard cable)
738696-281	Keyboard for 15.6-in models for use in Thailand (includes keyboard cable)

Spare part number	Description
738696-291	Keyboard for 15.6-in models for use in Japan (includes keyboard cable, backlight cable, and pointing stick cable)
738696-A41	Keyboard for 15.6-in models for use in Belgium (includes keyboard cable)
738696-AB1	Keyboard for 15.6-in models for use in Taiwan (includes keyboard cable)
738696-AD1	Keyboard for 15.6-in models for use in South Korea (includes keyboard cable)
738696-B31	Keyboard for 15.6-in models for use in the Netherlands (includes keyboard cable)
738696-B71	Keyboard for 15.6-in models for use in Sweden and Finland (includes keyboard cable, backlight cable, and pointing stick cable)
738696-BA1	Keyboard for 15.6-in models for use in Slovenia (includes keyboard cable)
738696-BB1	Keyboard for 15.6-in models for use in Israel (includes keyboard cable)
738696-BG1	Keyboard for 15.6-in models for use in Switzerland (includes keyboard cable)
738696-D61	Keyboard for 15.6-in models for use in India (includes keyboard cable)
738696-DB1	Keyboard for 15.6-in models for use in Canada (includes keyboard cable)
738696-DD1	Keyboard for 15.6-in models for use in Iceland (includes keyboard cable)
738696-FL1	Keyboard for 15.6-in models for use in the Czech Republic and Slovakia (includes keyboard cable)
738696-FP1	Keyboard for 15.6-in models for use in Northwest Africa (includes keyboard cable)
738697-001	Keyboard with pointing stick for 15.6-in models for use in the United States (includes keyboard cable and pointing stick cable)
738697-031	Keyboard with pointing stick for 15.6-in models for use in the United Kingdom and Singapore (includes keyboard cable and pointing stick cable)
738697-041	Keyboard with pointing stick for 15.6-in models for use in Germany (includes keyboard cable and pointing stick cable)
738697-051	Keyboard with pointing stick for 15.6-in models for use in France (includes keyboard cable and pointing stick cable)
738697-061	Keyboard with pointing stick for 15.6-in models for use in Italy (includes keyboard cable and pointing stick cable)
738697-071	Keyboard with pointing stick for 15.6-in models for use in Spain (includes keyboard cable and pointing stick cable)
738697-081	Keyboard with pointing stick for 15.6-in models for use in Denmark (includes keyboard cable and pointing stick cable)
738697-091	Keyboard with pointing stick for 15.6-in models for use in Norway (includes keyboard cable and pointing stick cable)
738697-131	Keyboard with pointing stick for 15.6-in models for use in Portugal (includes keyboard cable and pointing stick cable)
738697-141	Keyboard with pointing stick for 15.6-in models for use in Turkey (includes keyboard cable and pointing stick cable)
738697-151	Keyboard with pointing stick for 15.6-in models for use in Greece (includes keyboard cable and pointing stick cable)
738697-161	Keyboard with pointing stick for 15.6-in models for use in Latin America (includes keyboard cable and pointing stick cable)

Spare part number	Description
738697-171	Keyboard with pointing stick for 15.6-in models for use in Saudi Arabia (includes keyboard cable and pointing stick cable)
738697-211	Keyboard with pointing stick for 15.6-in models for use in Hungary (includes keyboard cable and pointing stick cable)
738697-251	Keyboard with pointing stick for 15.6-in models for use in Russia (includes keyboard cable and pointing stick cable)
738697-261	Keyboard with pointing stick for 15.6-in models for use in Bulgaria (includes keyboard cable and pointing stick cable)
738697-271	Keyboard with pointing stick for 15.6-in models for use in Romania (includes keyboard cable and pointing stick cable)
738697-281	Keyboard with pointing stick for 15.6-in models for use in Thailand (includes keyboard cable and pointing stick cable)
738697-291	Keyboard with pointing stick for 15.6-in models for use in Japan (includes keyboard cable and pointing stick cable)
738697-A41	Keyboard with pointing stick for 15.6-in models for use in Belgium (includes keyboard cable and pointing stick cable)
738697-AB1	Keyboard with pointing stick for 15.6-in models for use in Taiwan (includes keyboard cable and pointing stick cable)
738697-AD1	Keyboard with pointing stick for 15.6-in models for use in South Korea (includes keyboard cable and pointing stick cable)
738697-B31	Keyboard with pointing stick for 15.6-in models for use in the Netherlands (includes keyboard cable and pointing stick cable)
738697-B71	Keyboard with pointing stick for 15.6-in models for use in Sweden and Finland (includes keyboard cable and pointing stick cable)
738697-BA1	Keyboard with pointing stick for 15.6-in models for use in Slovenia (includes keyboard cable and pointing stick cable)
738697-BB1	Keyboard with pointing stick for 15.6-in models for use in Israel (includes keyboard cable and pointing stick cable)
738697-BG1	Keyboard with pointing stick for 15.6-in models for use in Switzerland (includes keyboard cable and pointing stick cable)
738697-DB1	Keyboard with pointing stick for 15.6-in models for use in Canada (includes keyboard cable and pointing stick cable)
738697-DD1	Keyboard with pointing stick for 15.6-in models for use in Iceland (includes keyboard cable and pointing stick cable)
738697-FL1	Keyboard with pointing stick for 15.6-in models for use in the Czech Republic and Slovakia (includes keyboard cable and pointing stick cable)
738697-FP1	Keyboard with pointing stick for 15.6-in models for use in Northwest Africa (includes keyboard cable and pointing stick cable)
738699-001	Display hinge Kit for 15.6-in models (includes left and right hinges and display panel cable bracket)
738701-001	Power button board for 15.6-in models (includes cable)
738702-001	USB board for 15.6-in models (includes cable)
738703-001	Function button board for 15.6-in models (includes cable)

Spare part number	Description
738703-001	Function button board for 15.6-in models (includes cable)
738704-001	Optical drive transfer board for 15.6-in models (includes cable)
738705-001	Modem transfer board for select 15.6-in models (includes cable)
738706-001	Plastics Kit
738708-001	Top cover for 15.6-in models with 2-button TouchPad
738709-001	Top cover for 15.6-in models with 4-button TouchPad
738710-001	TouchPad for 15.6-in models with 2 buttons (includes bracket)
738711-001	TouchPad for 15.6-in models with 4 buttons (includes bracket)
738712-001	Display bezel for 14-in models
739997-001	Display panel for 15.6-in models, HD SVA AG flat
739998-001	Display panel for 15.6-in models, FHD SVA AG slim
739999-001	DVD±RW Double-Layer Combo Drive
740000-001	DVD-ROM Drive
740001-001	DVD-ROM SuperMulti Drive
744005-001	Smart card reader for 14-in models with 4-button TouchPad
744007-001	System board for use only on computer models equipped with shared memory, WWAN capability (includes replacement thermal material)
744007-501	System board for use only on computer models equipped with shared memory, WWAN capability, and the Windows 8 Standard operating system (includes replacement thermal material)
744007-601	System board for use only on computer models equipped with shared memory, WWAN capability, and the Windows 8 Professional operating system (includes and replacement thermal material)
744008-001	System board for use only on computer models equipped with discrete memory, WWAN capability (includes replacement thermal material)
744008-501	System board for use only on computer models equipped with discrete memory, WWAN capability, and the Windows 8 Standard operating system (includes replacement thermal material)
744008-601	System board for use only on computer models equipped with discrete memory, WWAN capability, and the Windows 8 Professional operating system (includes and replacement thermal material)
744009-001	System board for use only on computer models equipped with shared memory, WWAN capability (includes replacement thermal material)
744009-501	System board for use only on computer models equipped with shared memory, WWAN capability, and the Windows 8 Standard operating system (includes replacement thermal material)
744009-601	System board for use only on computer models equipped with shared memory, WWAN capability, and the Windows 8 Professional operating system (includes and replacement thermal material)
744010-001	System board for use only on computer models equipped with discrete memory, WWAN capability (includes replacement thermal material)
744010-501	System board for use only on computer models equipped with discrete memory, WWAN capability, and the Windows 8 Standard operating system (includes replacement thermal material)
744010-601	System board for use only on computer models equipped with discrete memory, WWAN capability, and the Windows 8 Professional operating system (includes and replacement thermal material)

Spare part number	Description
744013-001	Cable Kit for 15.6- models (includes power connector cable and RJ-45 (network) cable and replacement thermal material)
744015-001	System board for use only on computer models equipped with shared memory, WWAN capability (includes replacement thermal material)
744015-501	System board for use only on computer models equipped with shared memory, WWAN capability, and the Windows 8 Standard operating system (includes replacement thermal material)
744015-601	System board for use only on computer models equipped with shared memory, WWAN capability, and the Windows 8 Professional operating system (includes and replacement thermal material)
744016-001	System board for use only on computer models equipped with shared memory, WWAN capability, a modem (includes replacement thermal material)
744016-501	System board for use only on computer models equipped with shared memory, WWAN capability, a modem, and the Windows 8 Standard operating system (includes replacement thermal material)
744016-601	System board for use only on computer models equipped with shared memory, WWAN capability, a modem, and the Windows 8 Professional operating system (includes and replacement thermal material)
744017-001	System board for use only on computer models equipped with discrete memory, WWAN capability (includes replacement thermal material)
744017-501	System board for use only on computer models equipped with discrete memory, WWAN capability, and the Windows 8 Standard operating system (includes replacement thermal material)
744017-601	System board for use only on computer models equipped with discrete memory, WWAN capability, and the Windows 8 Professional operating system (includes and replacement thermal material)
744018-001	System board for use only on computer models equipped with discrete memory, a modem, WWAN capability (includes replacement thermal material)
744018-501	System board for use only on computer models equipped with discrete memory, WWAN capability, a modem, and the Windows 8 Standard operating system (includes replacement thermal material)
744018-601	System board for use only on computer models equipped with shared memory, WWAN capability, a modem, and the Windows 8 Professional operating system (includes and replacement thermal material)
744019-001	System board for use only on computer models equipped with shared memory, WWAN capability (includes replacement thermal material)
744019-501	System board for use only on computer models equipped with shared memory, WWAN capability, and the Windows 8 Standard operating system (includes replacement thermal material)
744019-601	System board for use only on computer models equipped with shared memory, WWAN capability, and the Windows 8 Professional operating system (includes and replacement thermal material)
744020-001	System board for use only on computer models equipped with shared memory, WWAN capability, a modem (includes replacement thermal material)
744020-501	System board for use only on computer models equipped with shared memory, WWAN capability, a modem, and the Windows 8 Standard operating system (includes replacement thermal material)
744020-601	System board for use only on computer models equipped with shared memory, WWAN capability, a modem, and the Windows 8 Professional operating system (includes and replacement thermal material)
744021-001	System board for use only on computer models equipped with discrete memory, WWAN capability (includes replacement thermal material)

Spare part number	Description
744021-501	System board for use only on computer models equipped with discrete memory, WWAN capability, and the Windows 8 Standard operating system (includes replacement thermal material)
744021-601	System board for use only on computer models equipped with discrete memory, WWAN capability, and the Windows 8 Professional operating system (includes and replacement thermal material)
744022-001	System board for use only on computer models equipped with discrete memory, a modem, WWAN capability (includes replacement thermal material)
744022-501	System board for use only on computer models equipped with discrete memory, WWAN capability, a modem, and the Windows 8 Standard operating system (includes replacement thermal material)
744022-601	System board for use only on computer models equipped with shared memory, WWAN capability, a modem, and the Windows 8 Professional operating system (includes and replacement thermal material)
744715-001	System board for use only on computer models equipped with shared memory, without WWAN capability (includes replacement thermal material)
744715-501	System board for use only on computer models equipped with shared memory, without WWAN capability, and the Windows 8 Standard operating system (includes replacement thermal material)
744715-601	System board for use only on computer models equipped with shared memory, without WWAN capability, and the Windows 8 Professional operating system (includes and replacement thermal material)
744820-001	Blu-ray ROM DVD±RW Combo Drive
744821-001	DVD-ROM 9.5-mm Drive
744822-001	DVD-ROM SuperMulti 9.5-mm Drive
745883-001	For use only computer models with shared memory and WWAN capability
745883-501	For use only on computer models with shared memory, the Windows 8 Standard operating system, and WWAN capability
745883-601	For use only on computer models with shared memory, the Windows 8 Professional operating system, and WWAN capability
745884-001	For use only computer models equipped with shared memory without WWAN capability
745884-501	For use only on computer models equipped with shared memory and the Windows 8 Standard operating system without WWAN capability
745884-601	For use only on computer models equipped with shared memory, the Windows 8 Professional operating system without WWAN capability
745887-001	System board for use only on 15.6-in models with shared memory, WWAN capability (includes replacement thermal material)
745887-501	System board for use only on 15.6-in models with shared memory, WWAN capability, and the Windows 8 Standard operating system (includes replacement thermal material)
745887-601	System board for use only on 15.6-in models with shared memory, WWAN capability, and the Windows 8 Professional operating system (includes and replacement thermal material)
745888-001	System board for use only on 15.6-in models with shared memory, without WWAN capability (includes replacement thermal material)
745888-501	System board for use only on 15.6-in models with shared memory, without WWAN capability, and the Windows 8 Standard operating system (includes replacement thermal material)

Spare part number	Description
745888-601	System board for use only on 15.6-in models with shared memory, without WWAN capability, and the Windows 8 Professional operating system (includes and replacement thermal material)
745889-001	Top cover and 2-button TouchPad for 15.6-in models
745890-001	Top cover and 4-button TouchPad for 15.6-in models
745891-001	USB board (includes cable and double-sided adhesive)
745893-001	Display bezel
747751-001	14-in HD AG WLED SVA eDP FLT display panel
747752-001	14-in HD+ AG WLED SVA eDP FLT
747753-001	14-in FHD AG WLED UWVA eDPslim PSR
747832-001	Intel 802.11 a/b/g/n 2x2 + BT 4.0 WLAN
748357-001	Service cover for 14-in models
748358-001	Service cover for 14-in models
748958-001	Smart card reader with 4-button TouchPad
749254-001	System board for use only on computer models equipped with shared memory and a modem (includes replacement thermal material)
749261-001	128-GB SATA-3 solid-state drive
749262-001	180-GB SATA-3 solid-state drive
749263-001	256-GB SATA-3 self-encrypting solid-state drive
749274-001	System board for use only on computer models equipped with shared memory (includes replacement thermal material)
749274-501	System board for use only on computer models equipped with shared memory and the Windows 8 Standard operating system (includes replacement thermal material)
749274-601	System board for use only on computer models equipped with shared memory and the Windows 8 Professional operating system (includes and replacement thermal material)
749277-001	128-GB mSATA-3 solid-state drive
749278-001	128-GB SATA-3 solid-state drive
749279-001	180-GB SATA-3 solid-state drive
749280-001	128-GB mSATA-3 solid-state drive for use in Brazil
749281-001	32-GB mSATA flash cache solid-state drive
749263-001	256-GB SATA-3 self-encrypting solid-state drive
749263-001	256-GB SATA-3 self-encrypting solid-state drive
749284-001	128-GB mSATA-3 solid-state drive
749285-001	128-GB mSATA-3 solid-state drive for use in Brazil
749286-001	180-GB mSATA-3 solid-state drive
749287-001	256-GB mSATA-3 solid-state self-encrypting drive
749609-001	Display panel HD SVA AG flat

Spare part number	Description
749610-001	Display panel HD SVA AG flat
749954-001	128-GB SATA-3 solid-state drive
749955-001	180-GB SATA-3 solid-state drive
749956-001	256-GB SATA-3 self-encrypting solid-state drive
749957-001	DVD-ROM 9.5-mm Drive
749958-001	DVD-ROM SuperMulti 9.5-mm Drive
749959-001	Blu-ray R/RE DVD±RW SuperMulti Double-Layer Combo Drive

4 Removal and replacement procedures preliminary requirements

Tools required

You will need the following tools to complete the removal and replacement procedures:

- Flat-bladed screw driver
- Magnetic screw driver
- Phillips P0 and P1 screw drivers

Service considerations

The following sections include some of the considerations that you must keep in mind during disassembly and assembly procedures.

 **NOTE:** As you remove each subassembly from the computer, place the subassembly (and all accompanying screws) away from the work area to prevent damage.

Plastic parts

 **CAUTION:** Using excessive force during disassembly and reassembly can damage plastic parts. Use care when handling the plastic parts. Apply pressure only at the points designated in the maintenance instructions.

Cables and connectors

⚠ CAUTION: When servicing the computer, be sure that cables are placed in their proper locations during the reassembly process. Improper cable placement can damage the computer.

Cables must be handled with extreme care to avoid damage. Apply only the tension required to unseat or seat the cables during removal and insertion. Handle cables by the connector whenever possible. In all cases, avoid bending, twisting, or tearing cables. Be sure that cables are routed in such a way that they cannot be caught or snagged by parts being removed or replaced. Handle flex cables with extreme care; these cables tear easily.

Drive handling

⚠ CAUTION: Drives are fragile components that must be handled with care. To prevent damage to the computer, damage to a drive, or loss of information, observe these precautions:

Before removing or inserting a hard drive, shut down the computer. If you are unsure whether the computer is off or in Hibernation, turn the computer on, and then shut it down through the operating system.

Before handling a drive, be sure that you are discharged of static electricity. While handling a drive, avoid touching the connector.

Before removing a diskette drive or optical drive, be sure that a diskette or disc is not in the drive and be sure that the optical drive tray is closed.

Handle drives on surfaces covered with at least one inch of shock-proof foam.

Avoid dropping drives from any height onto any surface.

After removing a hard drive, an optical drive, or a diskette drive, place it in a static-proof bag.

Avoid exposing an internal hard drive to products that have magnetic fields, such as monitors or speakers.

Avoid exposing a drive to temperature extremes or liquids.

If a drive must be mailed, place the drive in a bubble pack mailer or other suitable form of protective packaging and label the package "FRAGILE."

Grounding guidelines

Electrostatic discharge damage

Electronic components are sensitive to electrostatic discharge (ESD). Circuitry design and structure determine the degree of sensitivity. Networks built into many integrated circuits provide some protection, but in many cases, ESD contains enough power to alter device parameters or melt silicon junctions.

A discharge of static electricity from a finger or other conductor can destroy static-sensitive devices or microcircuitry. Even if the spark is neither felt nor heard, damage may have occurred.

An electronic device exposed to ESD may not be affected at all and can work perfectly throughout a normal cycle. Or the device may function normally for a while, and then degrade in the internal layers, reducing its life expectancy.

⚠ CAUTION: To prevent damage to the computer when you are removing or installing internal components, observe these precautions:

Keep components in their electrostatic-safe containers until you are ready to install them.

Before touching an electronic component, discharge static electricity by using the guidelines described in this section.

Avoid touching pins, leads, and circuitry. Handle electronic components as little as possible.

If you remove a component, place it in an electrostatic-safe container.

The following table shows how humidity affects the electrostatic voltage levels generated by different activities.

⚠ CAUTION: A product can be degraded by as little as 700 V.

Typical electrostatic voltage levels			
Event	Relative humidity		
	10%	40%	55%
Walking across carpet	35,000 V	15,000 V	7,500 V
Walking across vinyl floor	12,000 V	5,000 V	3,000 V
Motions of bench worker	6,000 V	800 V	400 V
Removing DIPS from plastic tube	2,000 V	700 V	400 V
Removing DIPS from vinyl tray	11,500 V	4,000 V	2,000 V
Removing DIPS from Styrofoam	14,500 V	5,000 V	3,500 V
Removing bubble pack from PCB	26,500 V	20,000 V	7,000 V
Packing PCBs in foam-lined box	21,000 V	11,000 V	5,000 V

Packaging and transporting guidelines

Follow these grounding guidelines when packaging and transporting equipment:

- To avoid hand contact, transport products in static-safe tubes, bags, or boxes.
- Protect ESD-sensitive parts and assemblies with conductive or approved containers or packaging.
- Keep ESD-sensitive parts in their containers until the parts arrive at static-free workstations.
- Place items on a grounded surface before removing items from their containers.
- Always be properly grounded when touching a component or assembly.
- Store reusable ESD-sensitive parts from assemblies in protective packaging or nonconductive foam.
- Use transporters and conveyors made of antistatic belts and roller bushings. Be sure that mechanized equipment used for moving materials is wired to ground and that proper materials are selected to avoid static charging. When grounding is not possible, use an ionizer to dissipate electric charges.

Workstation guidelines

Follow these grounding workstation guidelines:

- Cover the workstation with approved static-shielding material.
- Use a wrist strap connected to a properly grounded work surface and use properly grounded tools and equipment.
- Use conductive field service tools, such as cutters, screw drivers, and vacuums.
- When fixtures must directly contact dissipative surfaces, use fixtures made only of static-safe materials.
- Keep the work area free of nonconductive materials, such as ordinary plastic assembly aids and Styrofoam.
- Handle ESD-sensitive components, parts, and assemblies by the case or PCM laminate. Handle these items only at static-free workstations.
- Avoid contact with pins, leads, or circuitry.
- Turn off power and input signals before inserting or removing connectors or test equipment.

Equipment guidelines

Grounding equipment must include either a wrist strap or a foot strap at a grounded workstation.

- When seated, wear a wrist strap connected to a grounded system. Wrist straps are flexible straps with a minimum of one megohm $\pm 10\%$ resistance in the ground cords. To provide proper ground, wear a strap snugly against the skin at all times. On grounded mats with banana-plug connectors, use alligator clips to connect a wrist strap.
- When standing, use foot straps and a grounded floor mat. Foot straps (heel, toe, or boot straps) can be used at standing workstations and are compatible with most types of shoes or boots. On conductive floors or dissipative floor mats, use foot straps on both feet with a minimum of one megohm resistance between the operator and ground. To be effective, the conductive must be worn in contact with the skin.

The following grounding equipment is recommended to prevent electrostatic damage:

- Antistatic tape
- Antistatic smocks, aprons, and sleeve protectors
- Conductive bins and other assembly or soldering aids
- Nonconductive foam
- Conductive tabletop workstations with ground cords of one megohm resistance
- Static-dissipative tables or floor mats with hard ties to the ground
- Field service kits
- Static awareness labels
- Material-handling packages
- Nonconductive plastic bags, tubes, or boxes
- Metal tote boxes
- Electrostatic voltage levels and protective materials

The following table lists the shielding protection provided by antistatic bags and floor mats.

Material	Use	Voltage protection level
Antistatic plastics	Bags	1,500 V
Carbon-loaded plastic	Floor mats	7,500 V
Metallized laminate	Floor mats	5,000 V

5 Removal and replacement procedures for Customer Self-Repair parts

 **NOTE:** The Customer Self-Repair program is not available in all locations. Installing a part not supported by the Customer Self-Repair program may void your warranty. Check your warranty to determine if Customer Self-Repair is supported in your location.

Component replacement procedures

 **NOTE:** Please read and follow the procedures described here to access and replace Customer Self-Repair parts successfully.

 **NOTE:** Details about your computer, including model, serial number, product key, and length of warranty, are on the service tag at the bottom of your computer. See Service tag on page 16 for details.

This chapter provides removal and replacement procedures for Customer Self-Repair parts.

There are as many as 16 screws that must be removed, replaced, and/or loosened when servicing Customer Self-Repair parts. Make special note of each screw size and location during removal and replacement.

Battery

Description	Spare part number
9-cell, 100-WHr, 3.0-AHr, Li-ion battery	718757-001
9-cell, 73-WHr, 2.2-AHr, Li-ion battery	718756-001
8-cell, 83-WHr, 2.8-AHr, Li-ion battery	718755-001
8-cell, 75-WHr, 2.8-AHr, Li-ion battery	718754-001

Before removing the battery, follow these steps:

1. Turn off the computer. If you are unsure whether the computer is off or in Hibernation, turn the computer on, and then shut it down through the operating system.
2. Disconnect the power from the computer by unplugging the power cord from the computer.
3. Disconnect all external devices from the computer.

Remove the battery:

⚠ WARNING! To reduce potential safety issues, use only the user-replaceable battery provided with the computer, a replacement battery provided by HP, or a compatible battery purchased from HP.

⚠ CAUTION: Removing a user-replaceable battery that is the sole power source for the computer can cause loss of information. To prevent loss of information, save your work or shut down the computer through Windows before removing the battery.

1. Turn the computer upside down on a flat surface.
2. Slide the battery release latch **(1)** to release the battery.

📝 NOTE: The battery release latch automatically returns to its original position.

3. Remove the battery **(2)** from the computer.

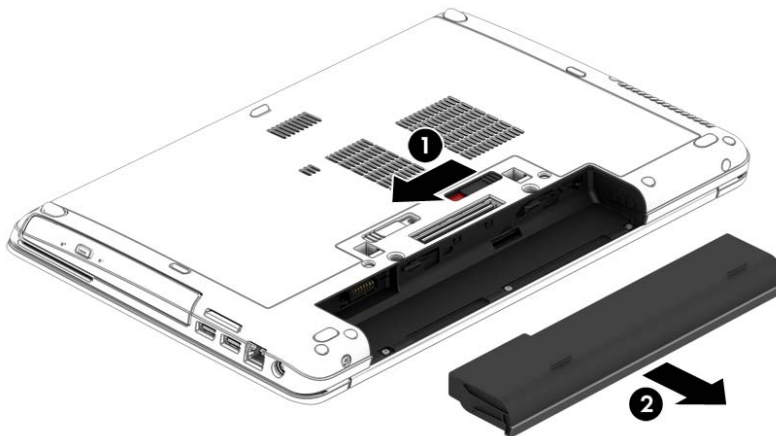

Reverse this procedure to install the battery.

Service cover

Description	Spare part number
Service cover for 15.6-in models	738691-001
Service cover for 14-in models	738680-001

Remove the service cover to access the memory module slot, hard drive, and other components.

1. Remove the battery (see [Battery on page 63](#)).
2. With the battery bay toward you, slide the service cover release latch **(1)** to the left, remove the screw (if the optional screw is being used) **(2)**, and then slide the release latch again **(3)** to release the service cover.

 **NOTE:** If you not want to use the optional screw, you can store it inside the service cover.

3. Slide the service cover toward the front of the computer **(4)** and lift **(5)** to remove the service cover.

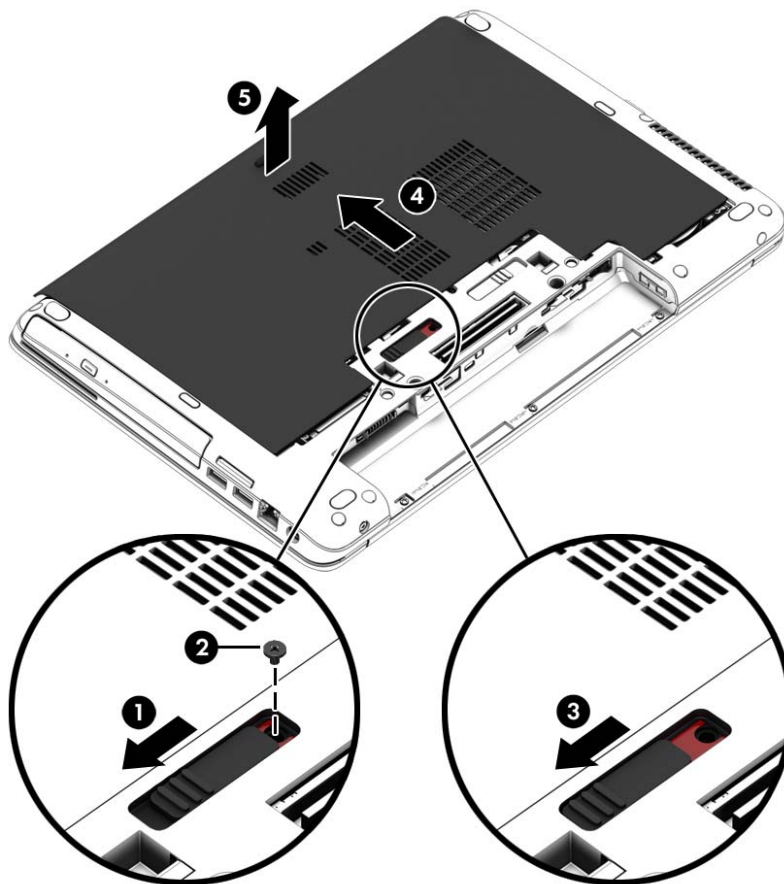

Reverse this procedure to install the service cover.

Hard drive



NOTE: The hard drive spare part kit does not include the hard drive bracket or screws. These components are included in the Hard Drive Hardware Kit, spare part number 738395-001.

Description	Spare part number
Hard drive (does not include hard drive bracket or screws):	
1-TB, 5400-rpm, 9.5-mm	676521-001
750-GB, 7200-rpm, 9.5-mm	633252-001
500-GB, 7200-rpm, 7.0-mm	703267-001
500-GB, 7200-rpm, 7.0-mm	634925-001
500-GB, 7200-rpm, 7.0-mm, self-encrypting	703268-001
500-GB, 5400-rpm, 7.0-mm, FIPS	730946-001
500-GB, 5400-rpm, 9.5-mm, self-encrypting	683801-001
500-GB, 5400-rpm, 7.0-mm	683802-001
320-GB, 7200-rpm, 9.5-mm	603783-001
320-GB, 7200-rpm, 7.0-mm	634862-001
320-GB, 5400-rpm, 7.0-mm	670035-001

Before removing the hard drive, follow these steps:

1. Save your work and shut down the computer.
2. Disconnect AC power and external devices connected to the computer.
3. Turn the computer upside down on a flat surface.
4. Remove the battery. (See [Battery on page 63](#)).

Remove the hard drive:

1. Disconnect the hard drive cable(1).

2. Loosen the 4 hard drive screws (2). Pull the hard drive tab (3) to the right to disconnect the hard drive.

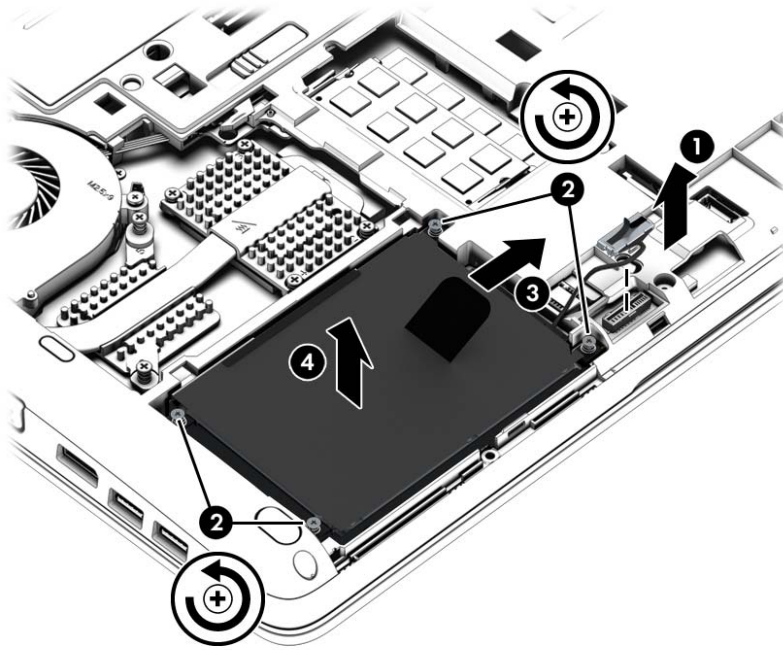

3. Lift the hard drive (4), and then pull the hard drive out of the hard drive bay.
4. If it is necessary to disassemble the hard drive, perform the following steps:
 - a. Position the hard drive with the hard drive tab toward you.
 - b. Remove the four Phillips screws (1) that secure the hard drive bracket to the hard drive.

- c. Remove the hard drive bracket (2) from the hard drive.

The hard drive bracket and screws are available in the Hard Drive Hardware Kit, spare part number 738395-001.

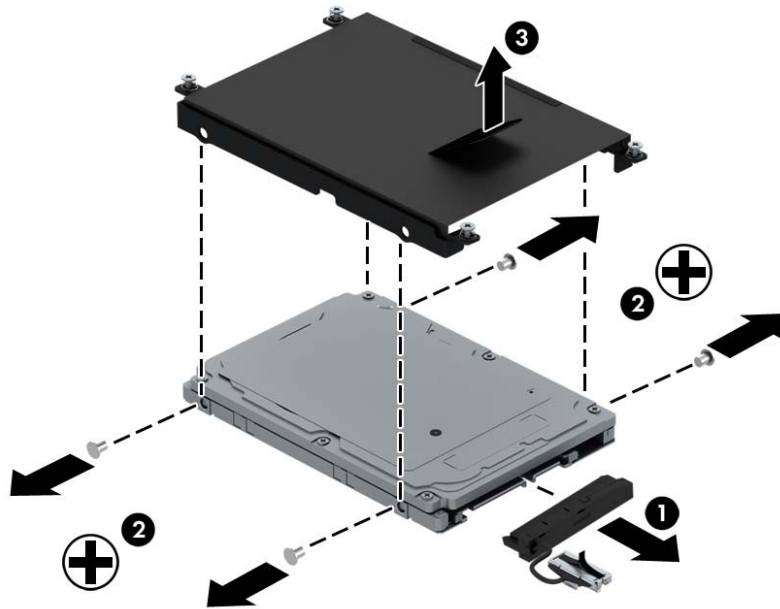

Reverse this procedure to install a hard drive.

Modem module (select models only)

Description	Spare part number
Modem module	628824-001

Before removing the modem module, follow these steps:

1. Turn off the computer. If you are unsure whether the computer is off or in Hibernation, turn the computer on, and then shut it down through the operating system.
2. Disconnect the power from the computer by unplugging the power cord from the computer.
3. Disconnect all external devices from the computer.
4. Remove the battery (see [Battery on page 63](#)).
5. Remove the service cover (see [Service cover on page 64](#)).

Remove the modem module:

1. Remove the two Phillips screws (1) that secure the modem module.

2. Lift the front of the modem module (2), and then disconnect the modem cable (3).

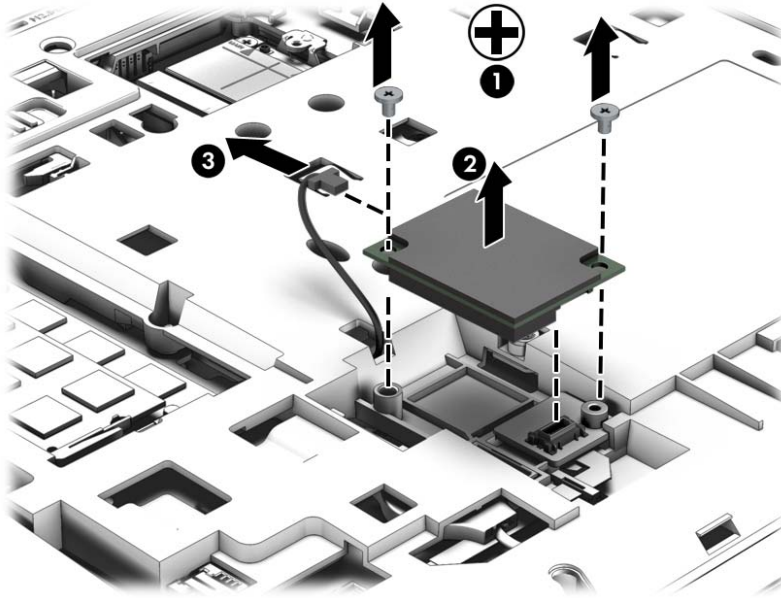

3. Release the modem module connector board from the clip, and then release the ZIF connector to remove modem module connector board.

Reverse this procedure to install a modem module.

Primary memory module

The computer has one memory module compartment. The capacity of the computer can be upgraded by adding a memory module to the vacant expansion memory module slot or by upgrading the existing memory module in the primary memory module slot.

WARNING! To reduce the risk of electric shock and damage to the equipment, unplug the power cord and remove all batteries before installing a memory module.

CAUTION: Electrostatic discharge (ESD) can damage electronic components. Before beginning any procedure, ensure that you are discharged of static electricity by touching a grounded metal object.

CAUTION: To prevent information loss or an unresponsive system:

Shut down the computer before adding or replacing memory modules. Do not remove a memory module while the computer is on, in the Sleep state, or in Hibernation.

If you are not sure whether the computer is off or in Hibernation, turn the computer on by pressing the power button. Then shut down the computer through the operating system.

NOTE: To use a dual-channel configuration when adding a second memory module, be sure that both memory modules are identical.

NOTE: The primary memory is located in the bottom memory slot and the expansion memory is located in the top memory slot.

Description	Spare part number
8-GB (PC3L, 12800, 1600-MHz)	693374-001

Description	Spare part number
4-GB (PC3L, 12800, 1600-MHz)	691740-001
2-GB (PC3L, 12800, 1600-MHz)	691739-001

To add or replace a memory module:

1. Save your work and shut down the computer.
2. Disconnect AC power and external devices connected to the computer.
3. Remove the battery (see [Battery on page 63](#)).
4. Remove the service cover (see [Service cover on page 64](#)).
5. If you are replacing a memory module, remove the existing memory module:
 - a. Pull away the retention clips (1) on each side of the memory module.
The memory module tilts up.
 - b. Grasp the edge of the memory module (2), and then gently pull the memory module out of the memory module slot.

CAUTION: To prevent damage to the memory module, hold the memory module by the edges only. Do not touch the components on the memory module.

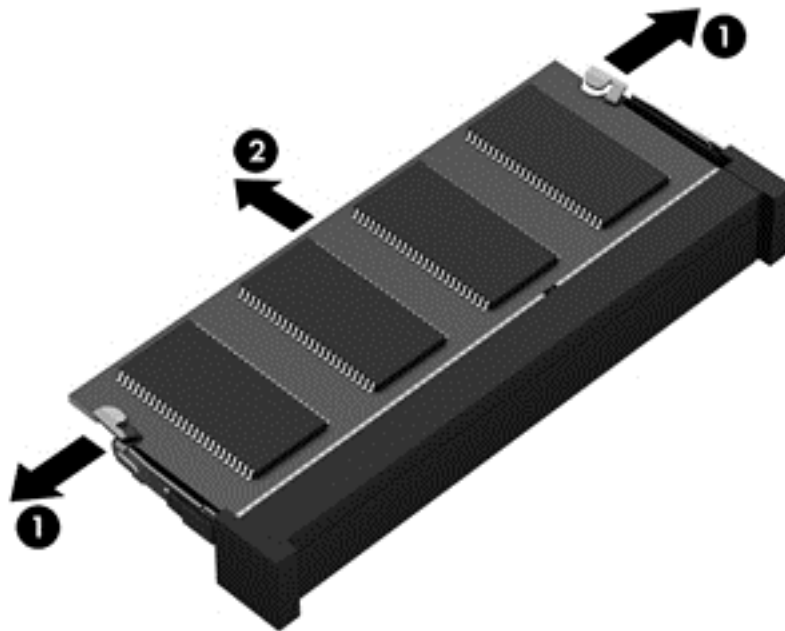

To protect a memory module after removal, place it in an electrostatic-safe container.

6. Insert a new memory module:

CAUTION: To prevent damage to the memory module, hold the memory module by the edges only. Do not touch the components on the memory module.

- a. Align the notched edge (1) of the memory module with the tab in the memory module slot.
- b. With the memory module at a 45-degree angle from the surface of the memory module compartment, press the module (2) into the memory module slot until it is seated.

- c. Gently press the memory module **(3)** down, applying pressure to both the left and right edges of the memory module, until the retention clips snap into place.

⚠ CAUTION: To prevent damage to the memory module, be sure that you do not bend the memory module.

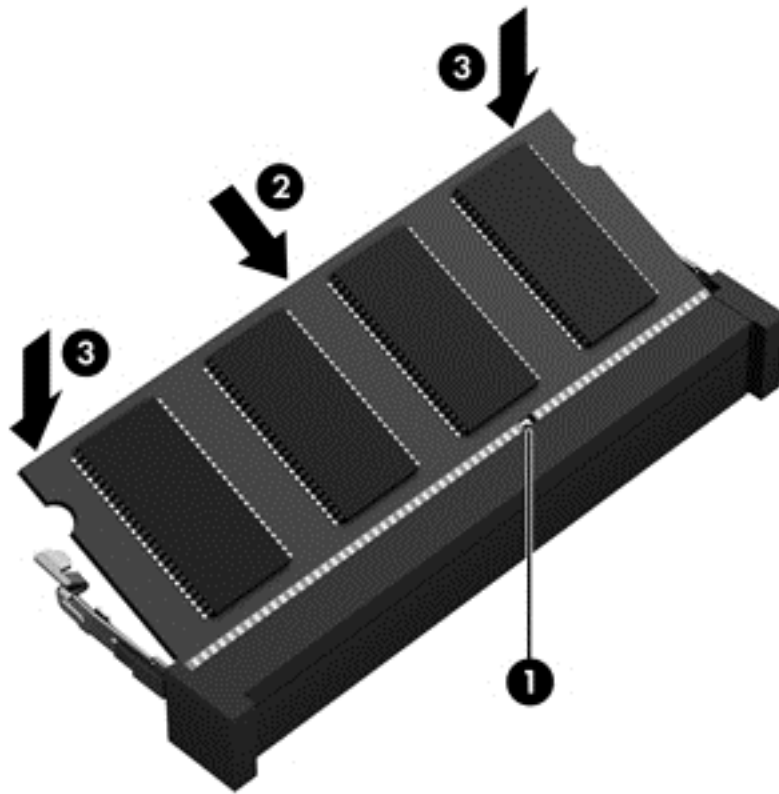

Reverse this procedure to install a memory module.

Expansion memory module

Update BIOS before adding memory modules

Before adding new memory, make sure you update the computer to the latest BIOS.

 **CAUTION:** Failure to update the computer to the latest BIOS prior to installing new memory may result in various system problems.

To update BIOS:

1. Navigate to www.hp.com.
2. Click **Support & Drivers** > click **Drivers & Software**.
3. In the **Enter a product name/number box**, type the computer model information, and then click **Search**.
4. Click the link for the computer model.
5. Select the operating system, and then click **Next**.
6. Under **Step 2: Select a Download**, click the **BIOS** link.
7. Click the link for the most recent BIOS.
8. Click the **Download** button, and then follow the on-screen instructions.

Before removing a memory module, follow these steps:

1. Turn off the computer. If you are unsure whether the computer is off or in Hibernation, turn the computer on, and then shut it down through the operating system.
2. Disconnect the power from the computer by unplugging the power cord from the computer.
3. Disconnect all external devices from the computer.
4. Remove the battery (see [Battery on page 63](#)).
5. Remove the service cover (see [Service cover on page 64](#)).

Remove the memory module:

1. Spread the retaining tabs **(1)** on each side of the memory module slot to release the memory module. (The memory module tilts up.)

2. Remove the memory module (2) by pulling the module away from the slot at an angle.

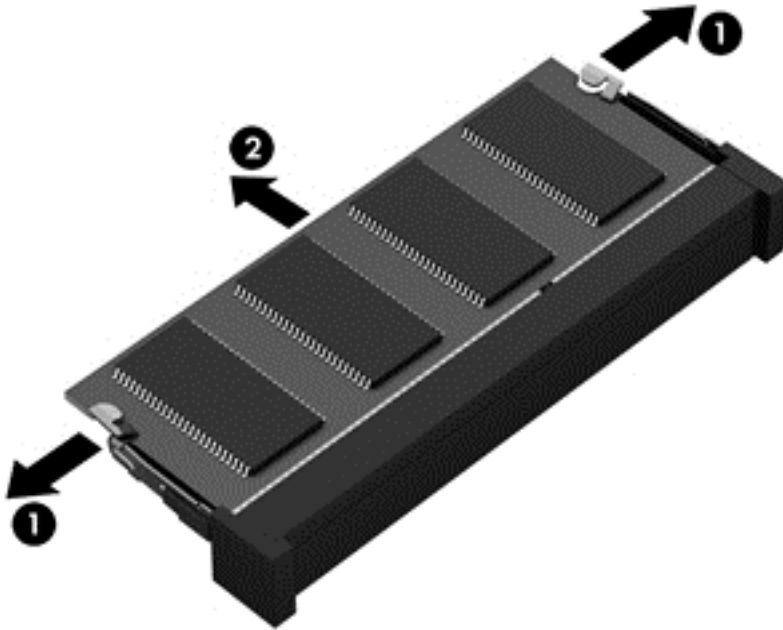

Reverse this procedure to install a memory module.

WWAN module (select models only)

Description	Spare part number
HP hs3110 HSPA+ Mobile Broadband Module	723895-001
HP It4112 LTE/HSPA+ Mobile Broadband Module	704031-001
HP It4111 LTE/EV-DO/HSPA+ Mobile Broadband Module	704030-001

CAUTION: To prevent an unresponsive system, replace the wireless module only with a wireless module authorized for use in the computer by the governmental agency that regulates wireless devices in your country or region. If you replace the module and then receive a warning message, remove the module to restore device functionality, and then contact technical support.

Before removing the WWAN module, follow these steps:

1. Turn off the computer. If you are unsure whether the computer is off or in Hibernation, turn the computer on, and then shut it down through the operating system.
2. Disconnect the power from the computer by unplugging the power cord from the computer.
3. Disconnect all external devices from the computer.
4. Remove the battery (see [Battery on page 63](#)).
5. Remove the service cover (see [Service cover on page 64](#)).

Remove the WWAN module:

1. Disconnect the WWAN antenna cables (1) from the terminals on the WWAN module.

NOTE: The WWAN antenna cable labeled “5” connects to the WWAN module “Main” terminal labeled “5”. The WWAN antenna cable labeled “6” connects to the WWAN module “Aux/GPS” terminal labeled “6”.

2. Remove the Phillips screw (2) that secures the WWAN module to the system board.
3. Remove the WWAN module (3) by pulling the module away from the slot at an angle.

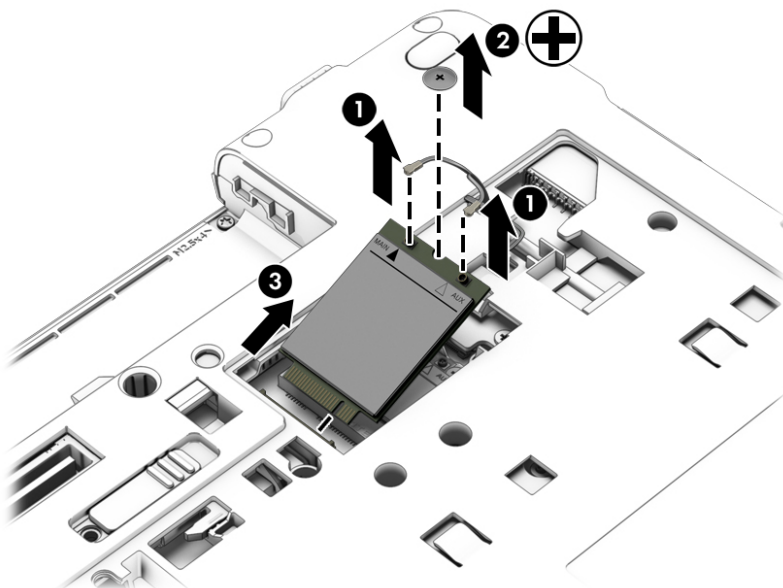



NOTE: If the WWAN antenna cables are not connected to the terminals on the WWAN module, protective sleeves should be installed on the antenna connectors, as shown in the following illustration.



Reverse this procedure to install the WWAN module.

WLAN module

Description	Spare part number
Intel 802.11 a/b/g/n 2x2 Combo Adapter	670292-001
Intel 802.11 b/g/n HMC 1x1	675794-001
Atheros 802.11 b/g/n 1x1	690019-001
Intel 802.11 2x2 a/b/g/n	695915-001
Intel 802.11 2x2 a/b/g/n	710661-001
Intel 802.11 a/b/g/n 2x2 + Bluetooth 4.0 WLAN	717381-001
Broadcom 802.11 a/b/g/n 2x2 + BT 4.0 LE PCIe+USB HMC WW	730668-001
Intel 802.11 a/b/g/n 2x2 + BT 4.0 WLAN	747832-001



CAUTION: To prevent an unresponsive system, replace the wireless module only with a wireless module authorized for use in the computer by the governmental agency that regulates wireless devices in your country or region. If you replace the module and then receive a warning message, remove the module to restore device functionality, and then contact technical support.

Before removing the WLAN module, follow these steps:

1. Turn off the computer. If you are unsure whether the computer is off or in Hibernation, turn the computer on, and then shut it down through the operating system.
2. Disconnect the power from the computer by unplugging the power cord from the computer.
3. Disconnect all external devices from the computer.
4. Remove the battery (see [Battery on page 63](#)).
5. Remove the service cover (see [Service cover on page 64](#)).

Remove the WLAN module:

1. Disconnect the WLAN antenna cables (1) from the terminals on the WLAN module.

 **NOTE:** The WLAN antenna cable labeled “1” connects to the WLAN module “Main” terminal labeled “1”. The WLAN antenna cable labeled “2” connects to the WLAN module “Aux” terminal labeled “2”.

2. Remove the two Phillips screws (2) that secure the WLAN module to the system board.)
3. Remove the WLAN module (3) by gently pulling the module away from the slot at an angle. (The WLAN module tilts up.)

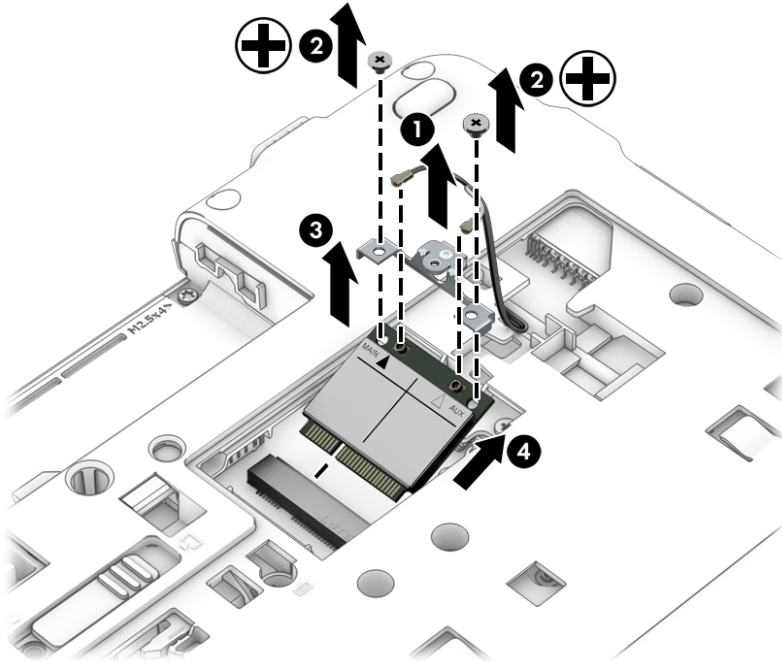

 **NOTE:** If the WLAN antenna cables are not connected to the terminals on the WLAN module, protective sleeves should be installed on the antenna connectors, as shown in the following illustration.

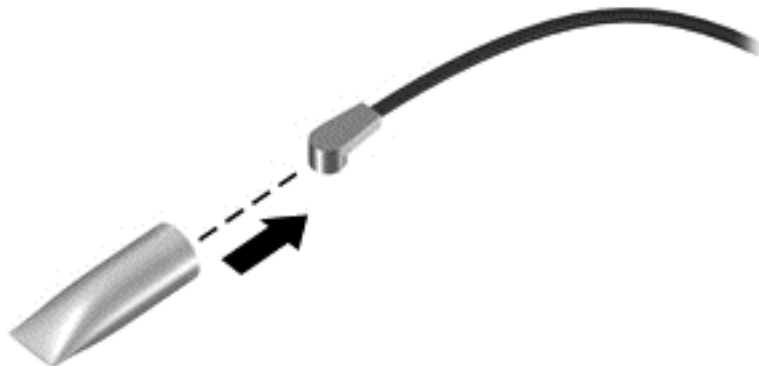

Reverse this procedure to install the WLAN module.

Optical drive



NOTE: The optical drive spare part kit includes a bezel and bracket.

Description	Spare part number
Blu-ray R/RE DVD±RW SuperMulti Double-Layer Combo Drive	749959-001
	739999-001
	744820-001
DVD±RW SuperMulti Double-Layer Drive	749958-001
	744822-001
	740001-001
DVD-ROM Drive	749957-001
	744821-001
	740000-001
	735601-001

Before removing the optical drive, follow these steps:

1. Turn off the computer. If you are unsure whether the computer is off or in Hibernation, turn the computer on, and then shut it down through the operating system.
2. Disconnect the power from the computer by unplugging the power cord from the computer.
3. Disconnect all external devices from the computer.
4. Remove the battery (see [Battery on page 63](#)).
5. Remove the service cover (see [Service cover on page 64](#)).

Remove the optical drive:

1. Position the computer with the left side toward you.
2. Loosen the captive screw **(1)** that secures the optical drive to the computer.
3. Insert a thin tool into the optical drive tab access **(2)**, and then press the tab to the left to release the optical drive from the computer.

4. Remove the optical drive (3).

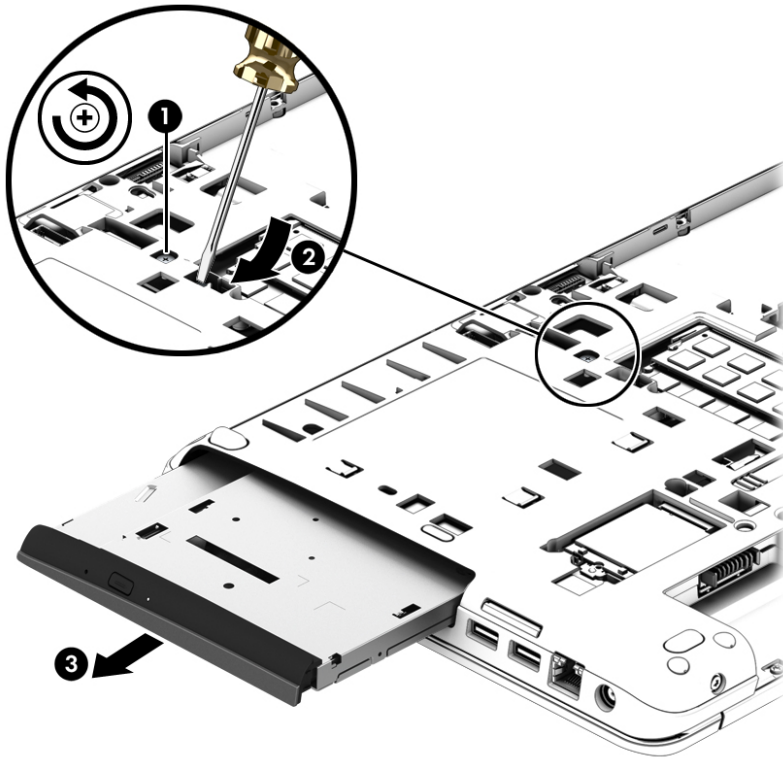

Reverse this procedure to install the optical drive.

Solid-state drive

Description	Spare part number
256-GB SATA-3 self-encrypting SSD	749263-001
180-GB SATA-3 SSD	749262-001
	749278-001
128-GB SATA-3 SSD	749261-001
	749277-001
128-GB mSATA-3 SSD for use in Brazil	749280-001
32-GB mSATA flash cache SSD	749281-001

Before removing the solid-state drive, follow these steps:

1. Turn off the computer. If you are unsure whether the computer is off or in Hibernation, turn the computer on, and then shut it down through the operating system.
2. Disconnect the power from the computer by unplugging the power cord from the computer.
3. Disconnect all external devices from the computer.
4. Remove the battery (see [Battery on page 63](#)).
5. Remove the service cover (see [Service cover on page 64](#)).

Remove the solid-state drive:

1. Remove the two Phillips screws (1) that secure the solid-state drive to the system board. (The solid-state drive tilts up.)
2. Remove the solid-state drive (2) by pulling the drive away from the slot at an angle.

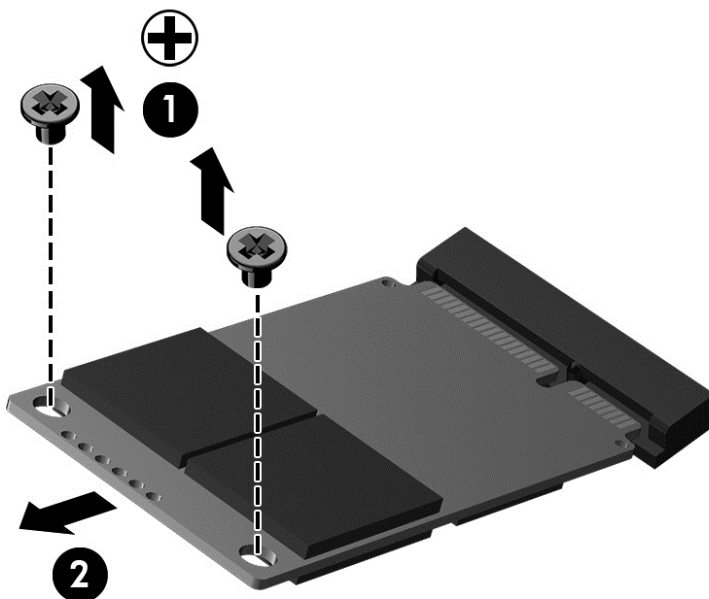

Reverse this procedure to install the solid-state drive.

Keyboard

For use in country or region	Spare part number	For use in country or region	Spare part number
Keyboard for 15" models (includes keyboard cable):			
For use in Belgium	738696-A41	For use in the Netherlands	738696-B31
For use in Brazil	738696-201	For use in Northwest Africa	738696-FP1
For use in Bulgaria	738696-261	For use in Norway	738696-091
For use in Canada	738696-DB1	For use in Portugal	738696-131
For use in the Czech Republic and Slovakia	738696-FL1	For use in Romania	738696-271
For use in Denmark	738696-051	For use in Russia	738696-251
For use in France	738696-041	For use in Saudi Arabia	738696-171
For use in Germany	738696-151	For use in Slovenia	738696-BA1
For use in Greece	738696-211	For use in Spain	738696-071
For use in Hungary	738696-061	For use in Sweden and Finland	738696-B71
For use in Iceland	738696-DD1	For use in Switzerland	738696-BG1
For use in India	738696-D61	For use in Taiwan	738696-AB1
For use in Israel	738696-BB1	For use in Thailand	738696-281
For use in Italy	738696-061	For use in Turkey	738696-141
For use in Japan	738696-291	For use in the United Kingdom	738696-031
For use in Korea	738696-AD1	For use in the United States	738696-001
For use in Latin America	738696-161		
Keyboard for 14" models (includes keyboard cable):			
For use in Belgium	738687-A41	For use in Northwest Africa	738687-FP1
For use in Bulgaria	738687-261	For use in Norway	738687-091
For use in Canada	738687-DB1	For use in Portugal	738687-131
For use in the Czech Republic and Slovakia	738687-FL1	For use in Romania	738687-271
For use in Denmark	738687-081	For use in Russia	738687-251
For use in France	738687-051	For use in Saudi Arabia	738687-171
For use in Germany	738687-041	For use in Slovenia	738687-BA1
For use in Greece	738687-151	For use in South Korea	738687-AD1
For use in Hungary	738687-211	For use in Spain	738687-071
For use in Iceland	738687-DD1	For use in Sweden and Finland	738687-B71
For use in India	738687-D61	For use in Switzerland	738687-BG1
For use in Israel	738687-BB1	For use in Taiwan	738687-AB1

For use in country or region	Spare part number	For use in country or region	Spare part number
For use in Italy	738687-061	For use in Thailand	738687-281
For use in Japan	738687-291	For use in Turkey	738687-141
For use in Latin America	738687-161	For use in the United Kingdom and Singapore	738687-031
For use in the Netherlands	738687-B31	For use in the United States	738687-001
Keyboard with pointing stick for 14" models (includes keyboard cable and pointing stick cable):			
For use in Belgium	738688-A41	For use in Northwest Africa	738688-FP1
For use in Brazil	738688-201	For use in Norway	738688-091
For use in Bulgaria	738688-261	For use in Portugal	738688-131
For use in Canada	738688-DB1	For use in Romania	738688-271
For use in the Czech Republic and Slovakia	738688-FL1	For use in Russia	738688-251
For use in Denmark	738688-081	For use in Saudi Arabia	738688-171
For use in France	738688-051	For use in Slovenia	738688-BA1
For use in Germany	738688-041	For use in South Korea	738688-AD1
For use in Greece	738688-151	For use in Spain	738688-071
For use in Hungary	738688-211	For use in Sweden and Finland	738688-B71
For use in Iceland	738688-DD1	For use in Switzerland	738688-BG1
For use in India	738688-D61	For use in Taiwan	738688-AB1
For use in Israel	738688-BB1	For use in Thailand	738688-281
For use in Italy	738688-061	For use in Turkey	738688-141
For use in Japan	738688-291	For use in the United Kingdom and Singapore	738688-031
For use in Latin America	738688-161	For use in the United States	738688-001
For use in the Netherlands	738688-B31		
Keyboard with pointing stick for 15" models (includes keyboard cable and pointing stick cable):			
For use in Belgium	738697-A41	For use in the Netherlands	738697-B31
For use in Brazil	738697-201	For use in Northwest Africa	738697-FP1
For use in Bulgaria	738697-261	For use in Norway	738697-091
For use in Canada	738697-DB1	For use in Portugal	738697-131
For use in the Czech Republic and Slovakia	738697-FL1	For use in Romania	738697-271
For use in Denmark	738697-051	For use in Russia	738697-251
For use in France	738697-041	For use in Saudi Arabia	738697-171
For use in Germany	738697-151	For use in Slovenia	738697-BA1

For use in country or region	Spare part number	For use in country or region	Spare part number
For use in Greece	738697-211	For use in Spain	738697-071
For use in Hungary	738697-061	For use in Sweden and Finland	738697-B71
For use in Iceland	738697-DD1	For use in Switzerland	738697-BG1
For use in India	738697-D61	For use in Taiwan	738697-AB1
For use in Israel	738697-BB1	For use in Thailand	738697-281
For use in Italy	738697-D61	For use in Turkey	738697-141
For use in Japan	738697-291	For use in the United Kingdom	738697-031
For use in Korea	738697-AD1	For use in the United States	738697-001
For use in Latin America	738697-161		

Before removing the keyboard, follow these steps:

1. Turn off the computer. If you are unsure whether the computer is off or in Hibernation, turn the computer on, and then shut it down through the operating system.
2. Disconnect the power from the computer by unplugging the power cord from the computer.
3. Disconnect all external devices from the computer.
4. Remove the battery (see [Battery on page 63](#)).
5. Remove the service cover (see [Service cover on page 64](#)).
6. Remove the optical drive (see [Optical drive on page 76](#)).

Remove the keyboard:

1. Loosen the two captive screws that secure the keyboard to the computer.

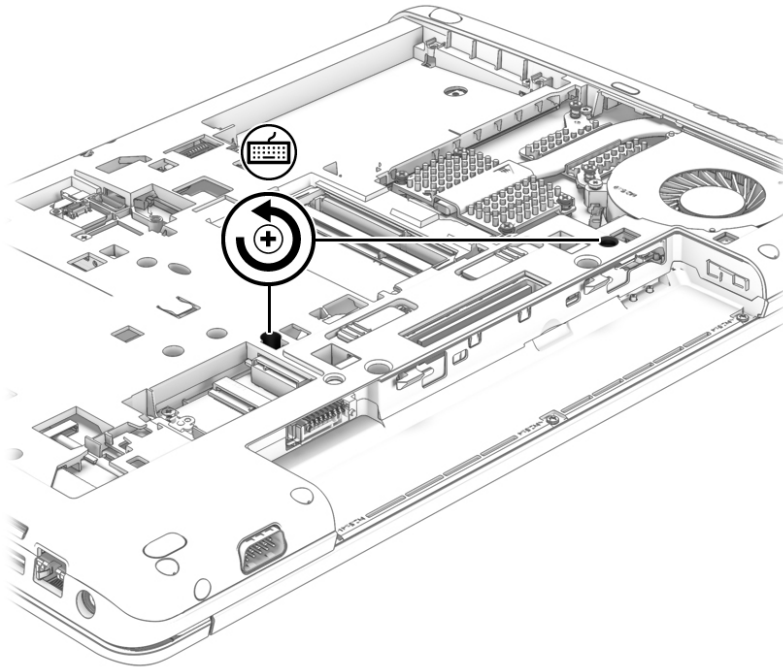

2. Open the computer.
3. Insert a thin tool (1) to loosen the tabs on the rear edge of the keyboard (2), and then lift the rear edge of the keyboard (3).

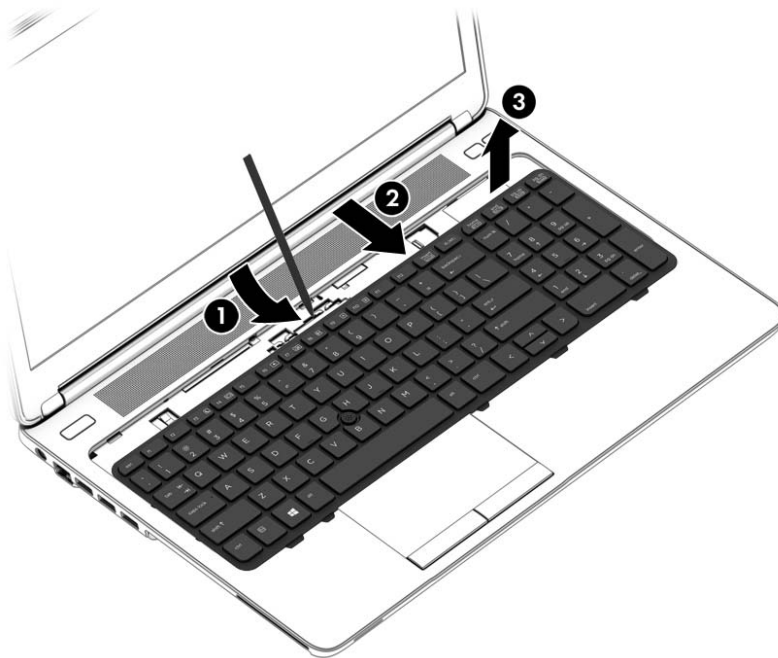

4. Swing the rear edge of the keyboard (1) up and forward until it rests upside down on the palm rest.

5. For models without a pointing stick, remove the metal shield (2) covering the zero insertion force (ZIF) connector, release the ZIF connector to which the keyboard cable is attached (3), remove the keyboard cable (4), and then remove the keyboard (5).

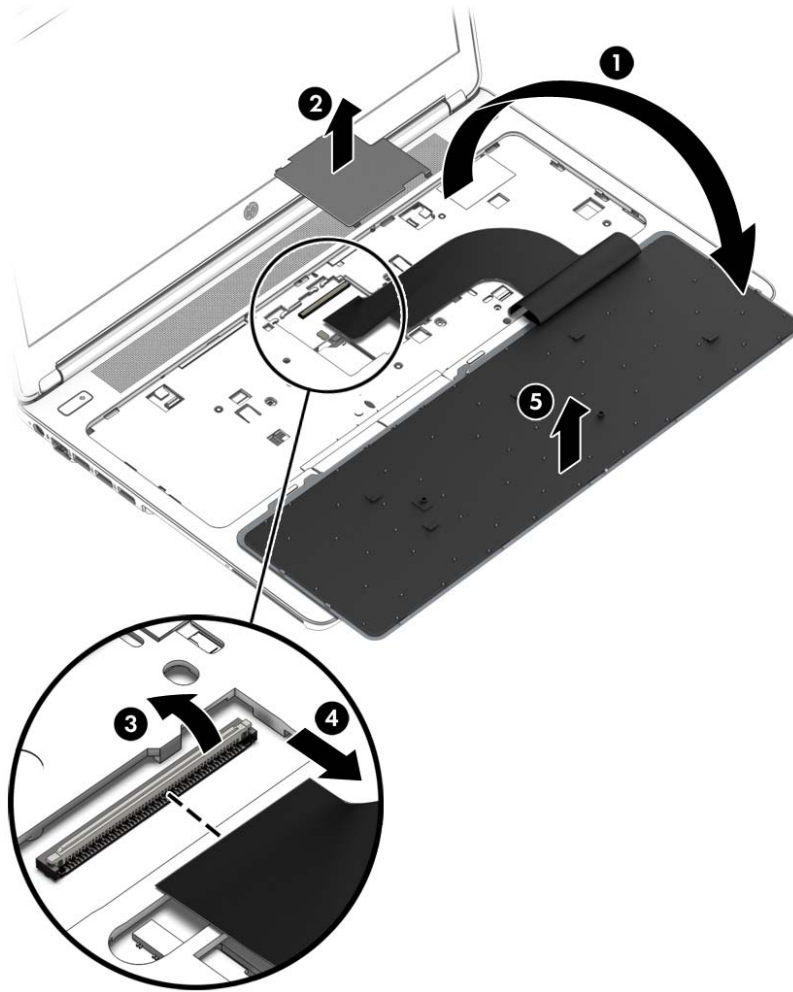

6. For models with a pointing stick, disconnect the pointing stick cable from the system board (32), release the zero insertion force (ZIF) connector to which the keyboard cable is attached (3), remove the keyboard cable (4), and then remove the keyboard (5)

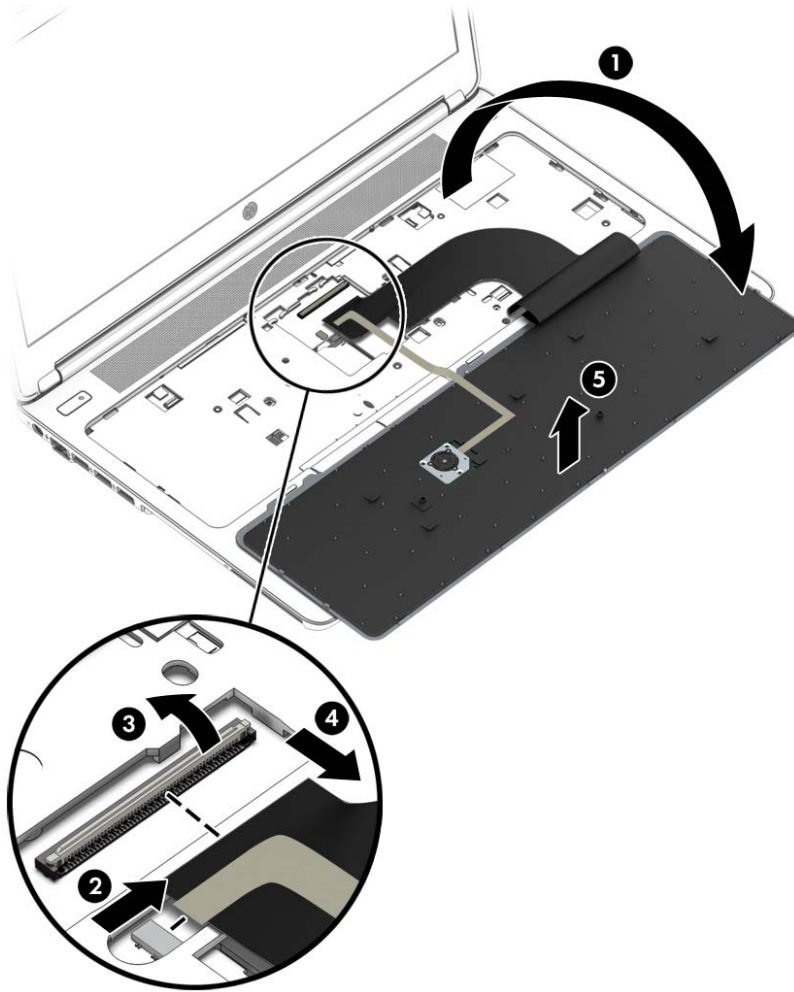

Reverse this procedure to install the keyboard.

6 Removal and replacement procedures for Authorized Service Provider parts

 **CAUTION:** Components described in this chapter should only be accessed by an authorized service provider. Accessing these parts can damage the computer or void the warranty.

Fan and heat sink assembly

 **NOTE:** The fan and heat sink assembly spare part kit includes replacement thermal material.

Description	Spare part number
Fan	738685-001
Heat sink for computer models with Intel UMA graphics	738686-001
Heat sink for computer models with discrete graphics	738393-001

Before removing the fan and heat sink assembly, follow these steps:

1. Turn off the computer. If you are unsure whether the computer is off or in Hibernation, turn the computer on, and then shut it down through the operating system.
2. Disconnect the power from the computer by unplugging the power cord from the computer.
3. Disconnect all external devices from the computer.
4. Remove the battery (see [Battery on page 63](#)), and then remove the following components:
 - a. Service cover (see [Service cover on page 64](#))
 - b. Hard drive (see [Hard drive on page 65](#))
 - c. Optical drive (see [Optical drive on page 76](#))
 - d. Keyboard (see [Keyboard on page 79](#))

Remove the fan:

1. Disconnect the fan cable (1) from the system board, loosen the two captive screws (2), and then remove the fan.

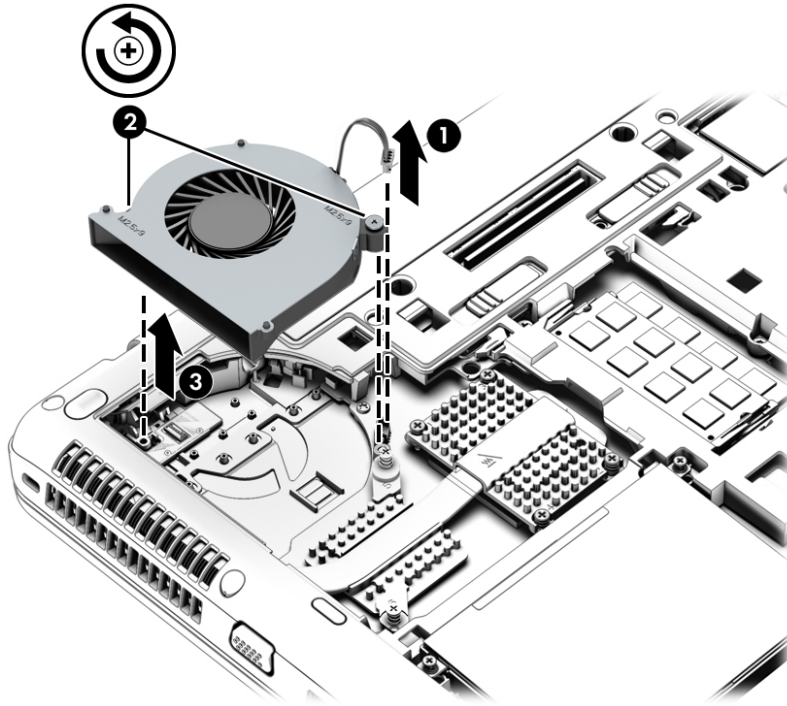

2. Remove the heat sink assembly:

 **NOTE:** Due to the adhesive quality of the thermal material located between the heat sink assembly and the system board components, it may be necessary to move the heat sink assembly from side to side to detach it.

- For computer models equipped with Intel UMA graphics, following the 1 through 4 sequence stamped into the processor heat sink, loosen the four Phillips captive screws that secure the processor heat sink to the system board, and then remove the heat sink (2).

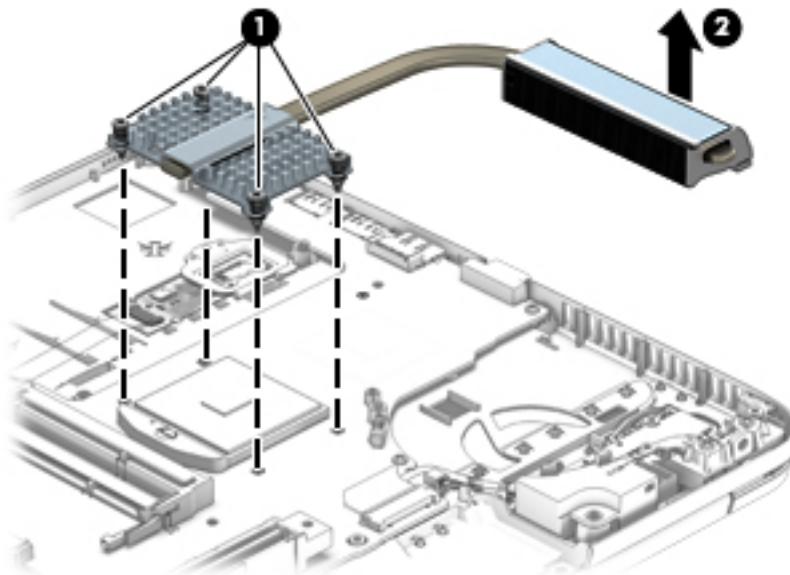

- For computer models equipped with discrete graphics, following the 1 through 2 sequence stamped into the graphics board heat sink, remove the 2 captive screws (1). Following the 1 through 4 sequence stamped into the processor heat sink, loosen the four Phillips captive screws that secure the processor heat sink to the system board (2), and then remove the heat sink assembly (3).

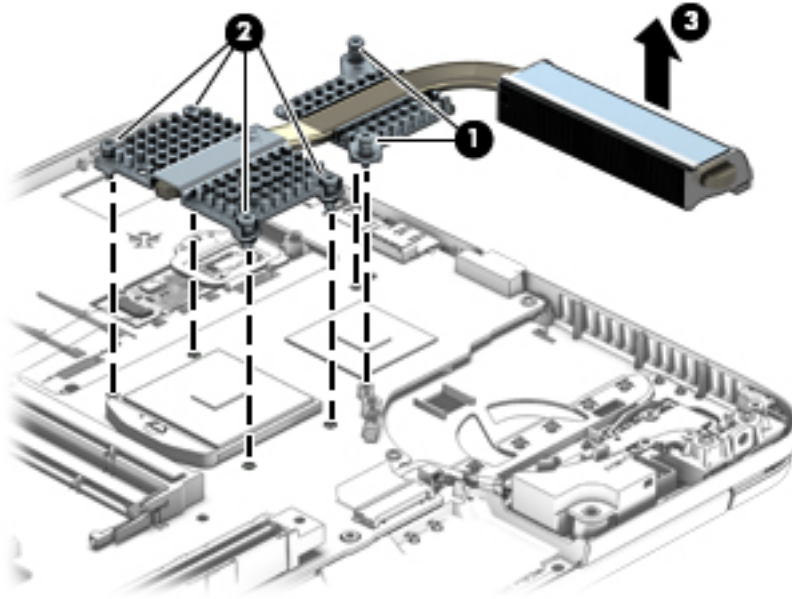

 **NOTE:** The thermal material must be thoroughly cleaned from the surfaces of the fan/heat sink assembly and the system board components each time the fan and heat sink assembly is removed. Replacement thermal material is included with the fan/heat sink assembly, processor, and system board spare part kits.

Thermal locations for computer models equipped with Intel UMA graphics are shown in the following illustration:

- Various thermal pads are used on the processor (1) and the heat sink section (2) that services it.

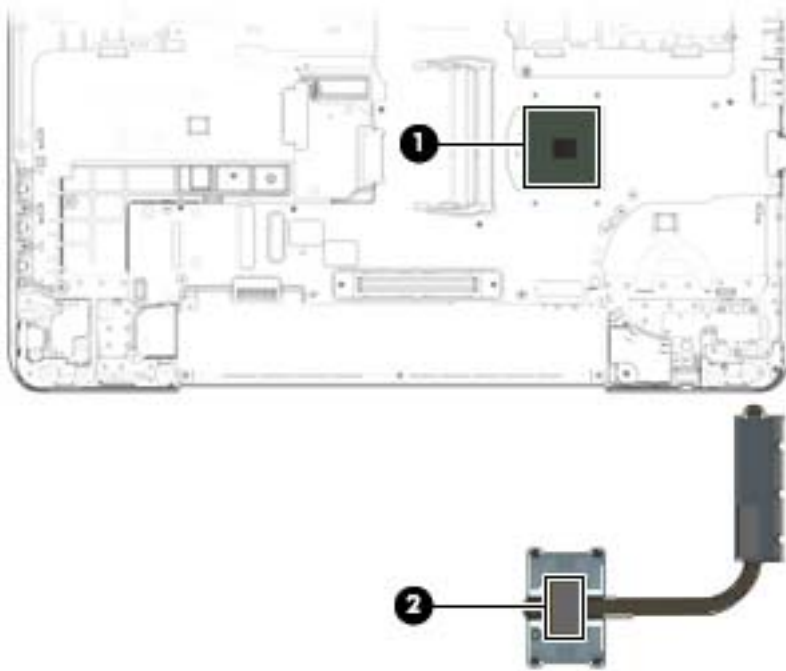

Thermal locations for computer models equipped with discrete graphics are shown in the following illustration:

- Thermal paste is used on the processor **(1)** and the heat sink section **(2)** that services it.
- Thermal paste is used on the graphics board processor **(3)** and the heat sink section **(4)** that services it

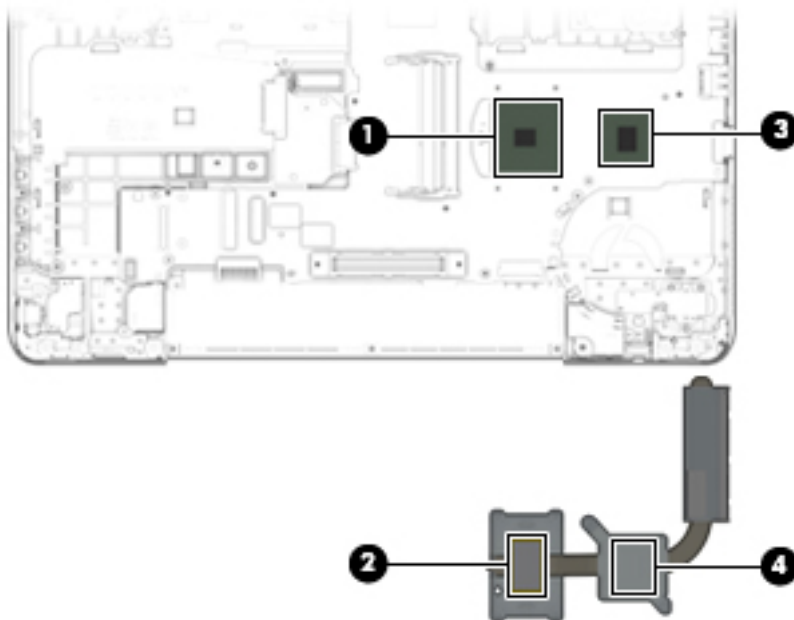

Reverse this procedure to install the fan/heat sink assembly.

Base enclosure

Description	Spare part number
Base enclosure	
For 15.6-in models	738692-001
For 14-in models	738681-001

Before removing the base enclosure, follow these steps:

1. Turn off the computer. If you are unsure whether the computer is off or in Hibernation, turn the computer on, and then shut it down through the operating system.
2. Disconnect the power from the computer by unplugging the power cord from the computer.
3. Disconnect all external devices from the computer.
4. Remove the battery (see [Battery on page 63](#)), and then remove the following components:
 - a. Service cover (see [Service cover on page 64](#))
 - b. Hard drive (see [Hard drive on page 65](#))
 - c. Optical drive (see [Optical drive on page 76](#))
 - d. Keyboard (see [Keyboard on page 79](#))
 - e. Fan and heat sink assembly (see [Fan and heat sink assembly on page 85](#))

Remove the base enclosure:

1. Remove the rubber screw covers.

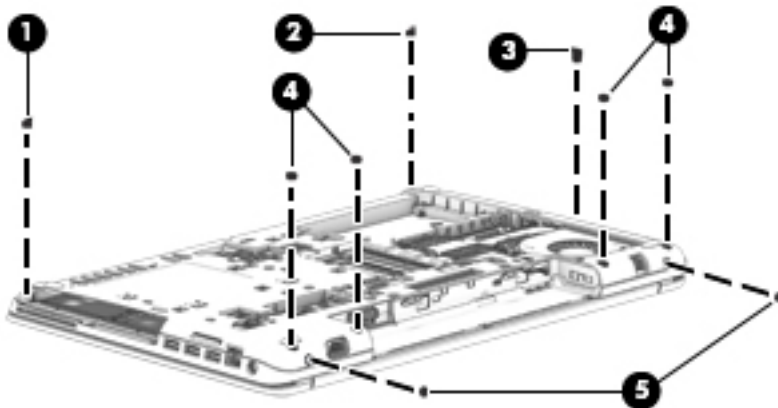

2. Remove the fourteen Torx T8 screws that secure the top cover to the computer.

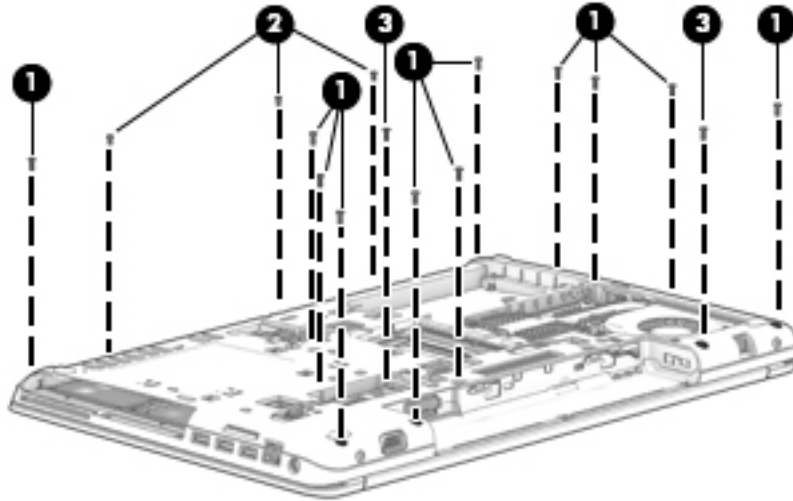

3. Remove the following screws that secure the base enclosure to the computer:

- (1) Two Torx T8 screws in the optical drive bay
- (2) Three Torx T8 screws in the battery bay
- (3) Two Phillips screws

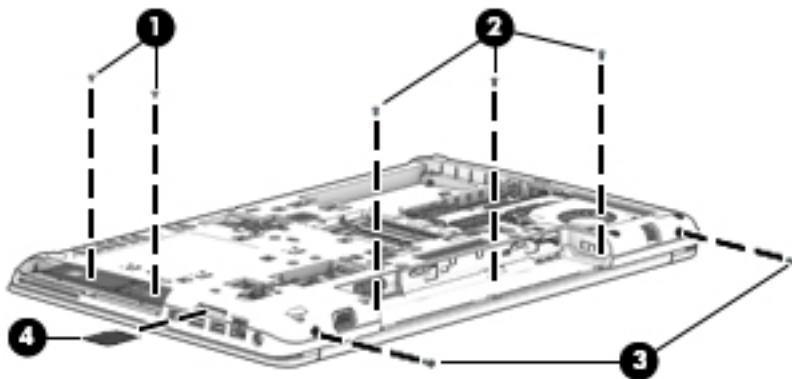

4. Remove the memory card (4).
5. Turn the computer right side up with the front toward you.
6. Lift the front edge of the base enclosure until the left and right sides and the rear edge detach from the computer.
7. Disconnect the serial connector cable from the system board.

8. Remove the base enclosure, making sure that the display panel cables and the wireless antenna cables route through the openings in the base enclosure.

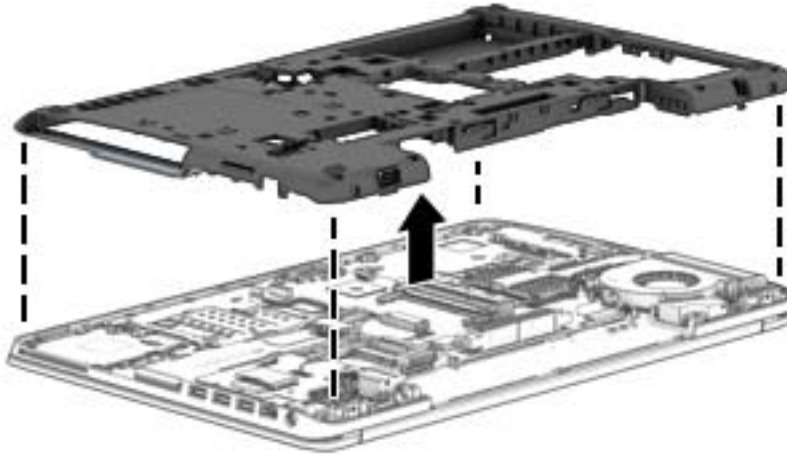

Reverse this procedure to install the base enclosure.

USB board

Description	Spare part number
USB board (includes cable)	735400-001
	738702-001
	745891-001

Before removing the USB board, follow these steps:

1. Turn off the computer. If you are unsure whether the computer is off or in Hibernation, turn the computer on, and then shut it down through the operating system.
2. Disconnect the power from the computer by unplugging the power cord from the computer.
3. Disconnect all external devices from the computer.
4. Remove the battery (see [Battery on page 63](#)), and then remove the following components:
 - a. Service cover (see [Service cover on page 64](#))
 - b. Hard drive (see [Hard drive on page 65](#))
 - c. Optical drive (see [Optical drive on page 76](#))
 - d. Keyboard (see [Keyboard on page 79](#))
 - e. Base enclosure (see [Base enclosure on page 89](#))

Remove the USB board:

1. Remove the four Phillips screws **(3)** that secure the USB board to the base enclosure.

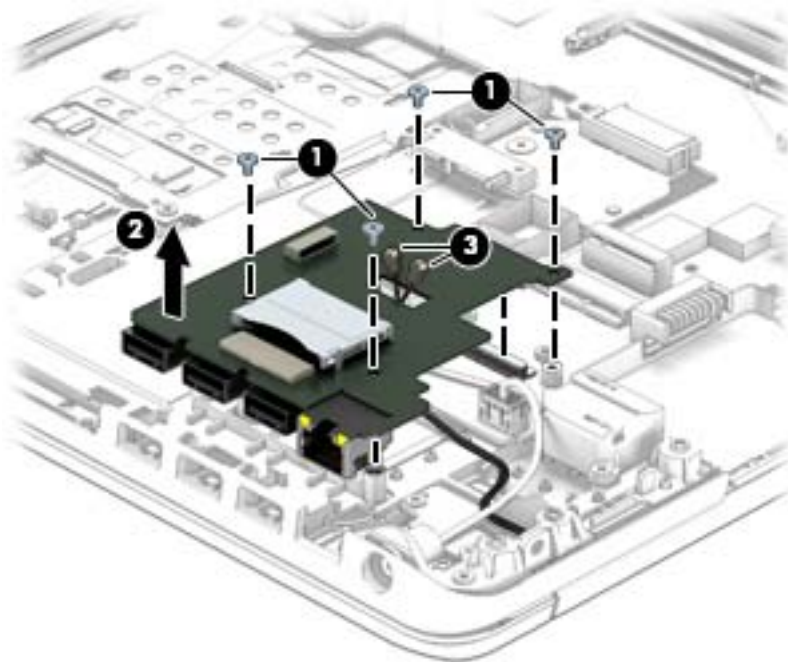

2. Lift up on the left side to disconnect the connector interface **(2)**.
 3. Detach the USB board cable from the base enclosure **(3)**, and remove the USB board and cable.
- Reverse this procedure to install the USB board.

Power button board

Description	Spare part number
Power button board (includes cable)	
For 15.6-in models	738701-001
For 14-in models	738399-001

Before removing the power button board, follow these steps:

1. Turn off the computer. If you are unsure whether the computer is off or in Hibernation, turn the computer on, and then shut it down through the operating system.
2. Disconnect the power from the computer by unplugging the power cord from the computer.
3. Disconnect all external devices from the computer.
4. Remove the battery (see [Battery on page 63](#)), and then remove the following components:
 - a. Service cover (see [Service cover on page 64](#))
 - b. Hard drive (see [Hard drive on page 65](#))
 - c. Optical drive (see [Optical drive on page 76](#))
 - d. Keyboard (see [Keyboard on page 79](#))
 - e. Base enclosure (see [Base enclosure on page 89](#))

Remove the power button board:

1. Turn the top cover upside down, with the front toward you.
2. Remove the Phillips PM2.0×3.0 screw **(1)** that secures the power button board to the top cover.
3. Release the clips **(2)** that secure the power button board to the top cover.

4. Remove the power button board (3) and cable.

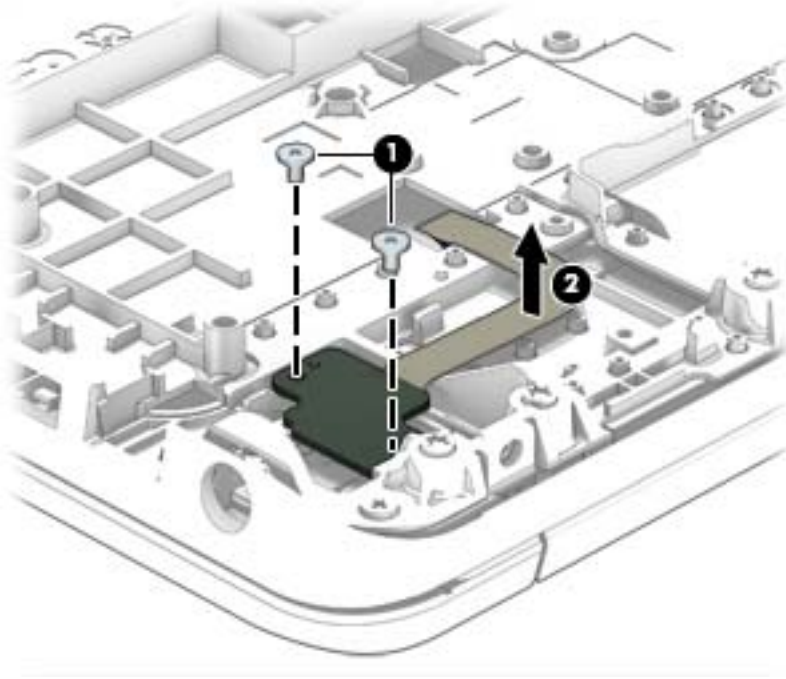

Reverse this procedure to install the power button board.

Fingerprint reader board

Description	Spare part number
Fingerprint reader board (includes cable and double-sided adhesive)	738394-001

Before removing the fingerprint reader board, follow these steps:

1. Turn off the computer. If you are unsure whether the computer is off or in Hibernation, turn the computer on, and then shut it down through the operating system.
2. Disconnect the power from the computer by unplugging the power cord from the computer.
3. Disconnect all external devices from the computer.
4. Remove the battery (see [Battery on page 63](#)), and then remove the following components:
 - a. Service cover (see [Service cover on page 64](#))
 - b. Hard drive (see [Hard drive on page 65](#))
 - c. Optical drive (see [Optical drive on page 76](#))
 - d. Keyboard (see [Keyboard on page 79](#))
 - e. Base enclosure (see [Base enclosure on page 89](#))

Remove the fingerprint reader board:

1. Turn the top cover upside down with the front toward you.
2. Detach the fingerprint reader board cable **(1)** from the top cover. (The fingerprint reader board cable is attached to the top cover with tape.)
3. Remove the Phillips screw **(2)** that secures the fingerprint reader board and bracket to the top cover.

4. Slide the fingerprint reader board (2) bracket forward and remove the fingerprint reader board and cable(4).

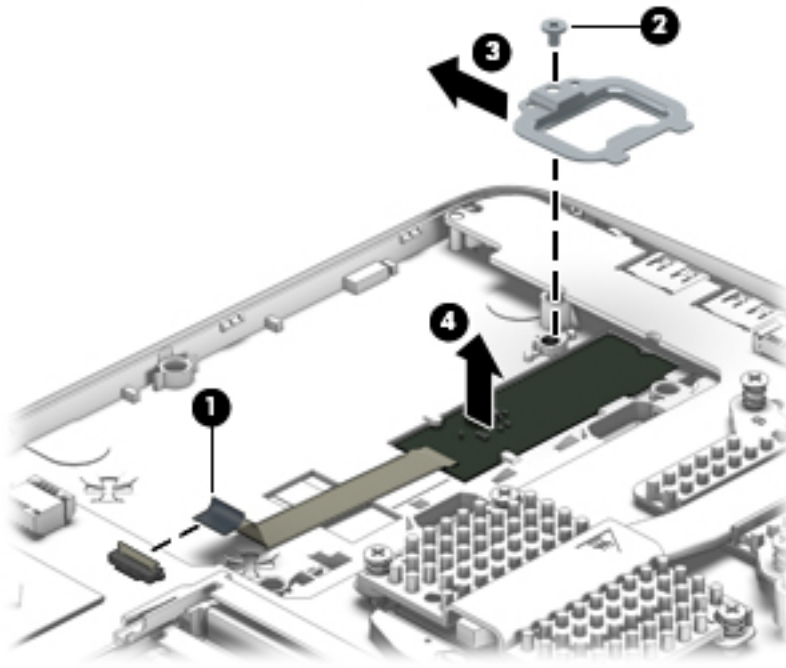

Reverse this procedure to install the fingerprint reader board.

Smart card reader

Description	Spare part number
Smart card reader for 14-in models with 2-button TouchPad (includes cable)	738398-001
Smart card reader for 14-in models with 4-button TouchPad (includes cable)	744005-001
Smart card reader 2-button (includes cable)	7738700-001
Smart card reader 4-button (includes cable)	738703-001

Before removing the smart card reader, follow these steps:

1. Turn off the computer. If you are unsure whether the computer is off or in Hibernation, turn the computer on, and then shut it down through the operating system.
2. Disconnect the power from the computer by unplugging the power cord from the computer.
3. Disconnect all external devices from the computer.
4. Remove the battery (see [Battery on page 63](#)), and then remove the following components:
 - a. Service cover (see [Service cover on page 64](#))
 - b. Hard drive (see [Hard drive on page 65](#))
 - c. Optical drive (see [Optical drive on page 76](#))
 - d. Keyboard (see [Keyboard on page 79](#))
 - e. Base enclosure (see [Base enclosure on page 89](#))

Remove the smart card reader:

1. Release the ZIF connector **(1)** to which the smart card reader cable is attached, and then disconnect the smart card reader cable from the system board.
2. Remove the two Torx screws **(2)** that secure the smart card reader to the base enclosure.

- Remove the smart card reader (3).

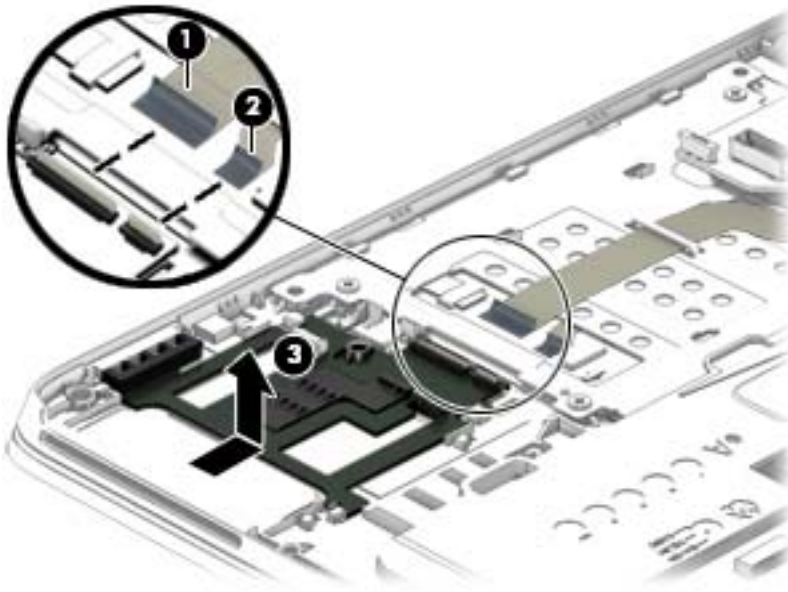

Reverse this procedure to install the smart card reader and cable.

System board

 **NOTE:** The system board spare part kit includes battery connector bracket and replacement thermal material.

Description	Spare part number
For 14-in. computer models with shared memory and WWAN capability (includes replacement thermal material)	744007-001
For 14-in. computer models with shared memory and the Windows 8 Standard operating system with WWAN capability (includes replacement thermal material)	744007-501
For 14-in. computer models with shared memory and the Windows 8 Professional operating system with WWAN capability (includes replacement thermal material)	744007-601
For 14-in. computer models with discrete memory and WWAN capability (includes replacement thermal material)	744008-001
For 14-in. computer models with discrete memory and the Windows 8 Standard operating system with WWAN capability (includes replacement thermal material)	744008-501
For 14-in. computer models with discrete memory and the Windows 8 Professional operating system with WWAN capability (includes replacement thermal material)	744008-601
For 14-in. computer models with discrete memory, WWAN capability (includes replacement thermal material)	744009-001
For 14-in. computer models with discrete memory and the Windows 8 Standard operating system with WWAN capability (includes replacement thermal material)	744009-501
For 14-in. computer models with shared memory and the Windows 8 Professional operating system with WWAN capability (includes replacement thermal material)	744009-601
For 14-in. computer models with discrete memory and WWAN capability (includes replacement thermal material)	744010-001

Description	Spare part number
For 14-in. computer models with discrete memory and the Windows 8 Standard operating system with WWAN capability (includes replacement thermal material)	744010-501
For 14-in. computer models with shared memory and the Windows 8 Professional operating system with WWAN capability (includes replacement thermal material)	744010-601
For 15.6-in. computer models with discrete memory, WWAN capability (includes replacement thermal material)	744015-001
For 15.6-in. computer models with discrete memory and the Windows 8 Standard operating system with WWAN capability (includes replacement thermal material)	744015-501
For 15.6-in. computer models with discrete memory and the Windows 8 Professional operating system with WWAN capability (includes replacement thermal material)	744015-601
For 15.6-in. computer models with shared memory, WWAN capability (includes replacement thermal material)	744016-001
For 15.6-in. computer models with shared memory and the Windows 8 Standard operating system with WWAN capability (includes replacement thermal material)	744016-501
For 15.6-in. computer models with shared memory and the Windows 8 Professional operating system with WWAN capability (includes replacement thermal material)	744016-601
For 15.6-in. computer models with shared memory, WWAN capability (includes replacement thermal material)	744017-001
For 15.6-in. computer models with shared memory and the Windows 8 Standard operating system with WWAN capability (includes replacement thermal material)	744017-501
For 15.6-in. computer models with shared memory and the Windows 8 Professional operating system with WWAN capability (includes replacement thermal material)	744017-601
For 14-in. computer models equipped with shared memory with WWAN capability	745883-001
For 14-in. computer models equipped with shared memory and the Windows 8 Standard operating system with WWAN capability	745883-501
For 14-in. computer models with shared memory and the Windows 8 Professional operating system with WWAN capability	745883-601
For 14-in. computer models shared memory without WWAN capability	745884-001
For computer models equipped with shared memory and the Windows 8 Standard operating system without WWAN capability	745884-501
For use only on computer models shared memory and the Windows 8 Professional operating system without WWAN capability	745884-601
For use only on 15.6-in. computer models equipped with an Intel Quad Core processor with WWAN capability	745887-001
For use only on 15.6-in. computer models shared memory and the Windows 8 Standard operating system with WWAN capability	745887-501
For use only on 15.6-in. computer models with shared memory and the Windows 8 Professional operating system with WWAN capability	745887-601
For use only on 15.6-in. computer models with shared memory and the Windows 8 Standard operating system without WWAN capability	745888-501
For use only on 15.6-in. computer models with shared memory and the Windows 8 Professional operating system without WWAN capability	745888-601
For use only on 15.6-in. computer models with shared memory and without WWAN capability	745888-001

Before removing the system board, follow these steps:

1. Turn off the computer. If you are unsure whether the computer is off or in Hibernation, turn the computer on, and then shut it down through the operating system.
2. Disconnect the power from the computer by unplugging the power cord from the computer.
3. Disconnect all external devices from the computer.
4. Remove the battery (see [Battery on page 63](#)), and then remove the following components:
 - a. Service cover (see [Service cover on page 64](#))
 - b. Hard drive (see [Hard drive on page 65](#))
 - c. Optical drive (see [Optical drive on page 76](#))
 - d. Fan/heat sink assembly (see [Fan and heat sink assembly on page 85](#))
 - e. Keyboard (see [Keyboard on page 79](#))
 - f. Display assembly (see [Display assembly on page 115](#))
 - g. Base enclosure (see [Base enclosure on page 89](#))
 - h. USB board (see [USB board on page 92](#))



NOTE: When replacing the system board, be sure that the following components are removed from the defective system board and installed on the replacement system board:

- WWAN module (see [WWAN module \(select models only\) on page 73](#))
- Solid-state drive (see [Solid-state drive on page 78](#))
- WLAN module (see [WLAN module on page 74](#))
- Expansion memory (see [Primary memory module on page 68](#))
- Primary memory (see [Expansion memory module on page 71](#))
- Smart card reader (see [Smart card reader on page 98](#))
- Processor (see [Processor on page 108](#))

Remove the system board:

1. Disconnect the following cables from the system board:
 - (1) Card reader cable
 - (2) Power connector cable
 - Left (3) and right (4) speaker cables
 - (5) Display panel cable (if display panel is still attached)

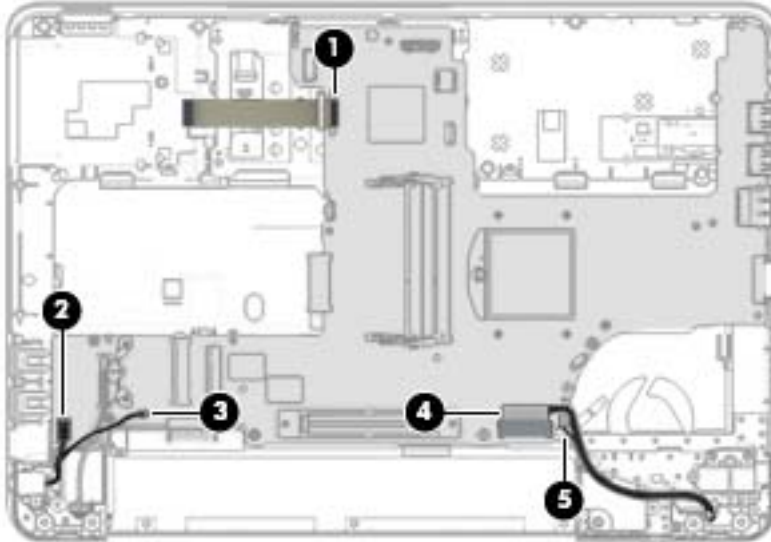

2. Remove the five Torx screws (1) and the Phillips screw (2) that secure the system board to the base enclosure.

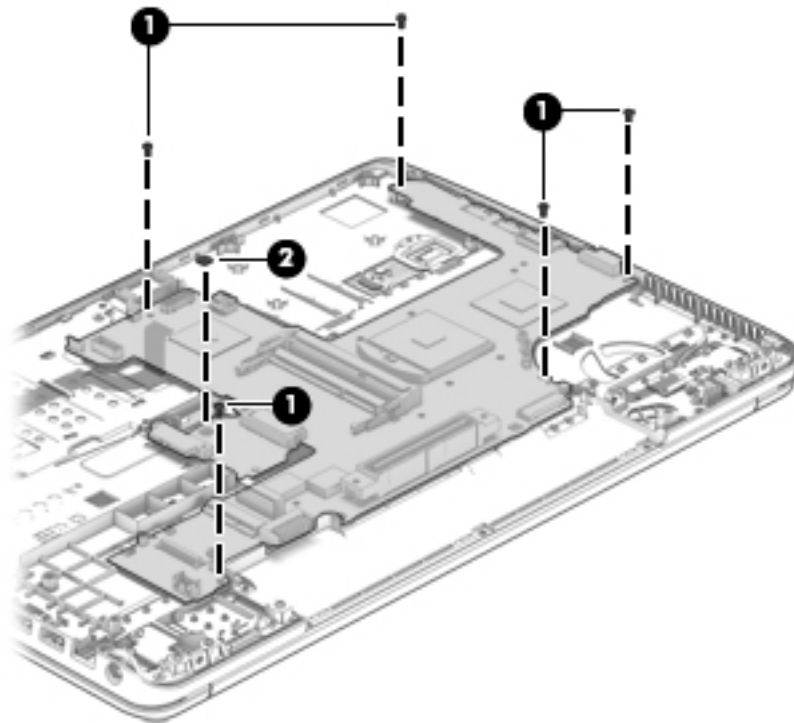

3. Lift up on the left side of the system board **(1)** until it rests at an angle.
4. Remove the system board **(2)** by sliding it up and to the left at an angle.

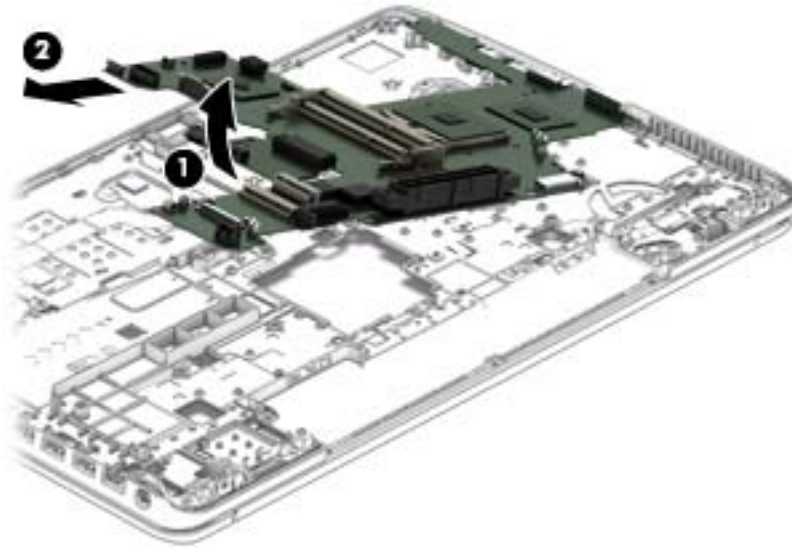

Reverse this procedure to install the system board.

Speakers

Description	Spare part number
Speakers (includes cable)	738404-001

Before removing the speakers, follow these steps:

1. Turn off the computer. If you are unsure whether the computer is off or in Hibernation, turn the computer on, and then shut it down through the operating system.
2. Disconnect the power from the computer by unplugging the power cord from the computer.
3. Disconnect all external devices from the computer.
4. Remove the battery (see [Battery on page 63](#)), and then remove the following components:
 - a. Service cover (see [Service cover on page 64](#))
 - b. Hard drive (see [Hard drive on page 65](#))
 - c. Optical drive (see [Optical drive on page 76](#))
 - d. Keyboard (see [Keyboard on page 79](#))
 - e. Base enclosure (see [Base enclosure on page 89](#))

Remove the speakers:

1. Disconnect the speaker cables **(1)** and **(4)** from the system board.
2. Remove the two Phillips PM2.0×3.0 screws **(2)** and **(5)** that secure the speakers to the base enclosure.

3. Remove the speakers (3) and (6) and cables.

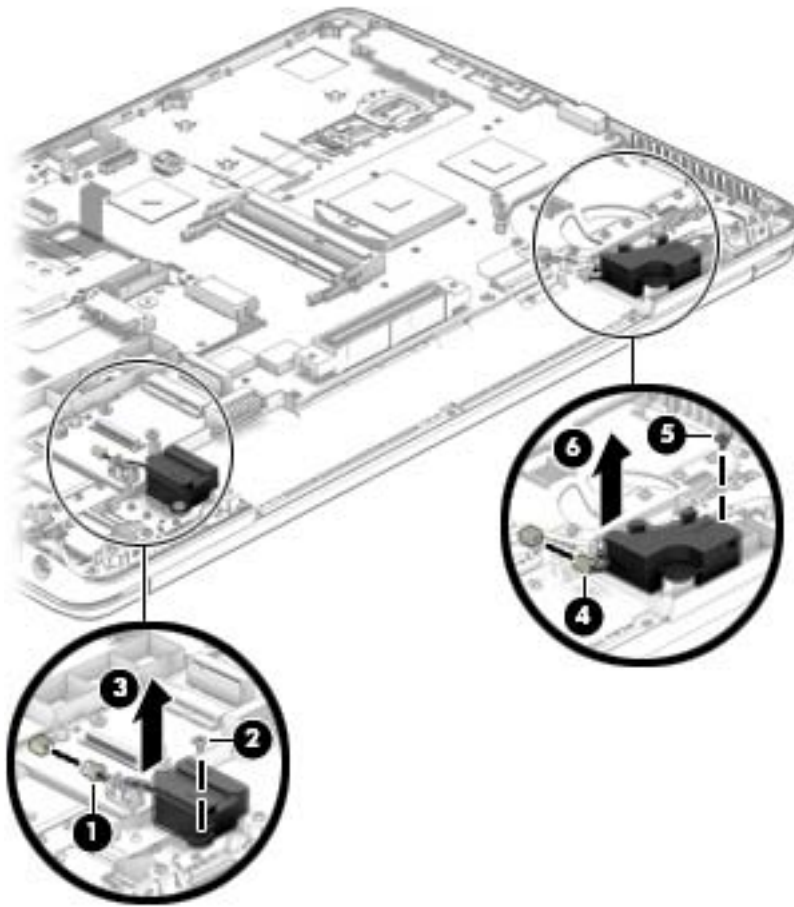

Reverse this procedure to install the speakers.

Function button board

Description	Spare part number
Function button board (includes cable and double-sided adhesive)	738703-001
	738401-001

Before removing the function button board, follow these steps:

1. Turn off the computer. If you are unsure whether the computer is off or in Hibernation, turn the computer on, and then shut it down through the operating system.
2. Disconnect the power from the computer by unplugging the power cord from the computer.
3. Disconnect all external devices from the computer.
4. Remove the battery (see [Battery on page 63](#)), and then remove the following components:
 - a. Service cover (see [Service cover on page 64](#))
 - b. Hard drive (see [Hard drive on page 65](#))
 - c. Optical drive (see [Optical drive on page 76](#))
 - d. Keyboard (see [Keyboard on page 79](#))
 - e. Base enclosure (see [Base enclosure on page 89](#))

Remove the function button board:

1. Turn the top cover upside down, with the front toward you.
2. Disconnect the function button board cable **(1)**.
3. Remove the Phillips PM2.0×3.0 screws **(2)** that secures the function button board to the top cover.

4. Lift the function button board (3) to remove it.

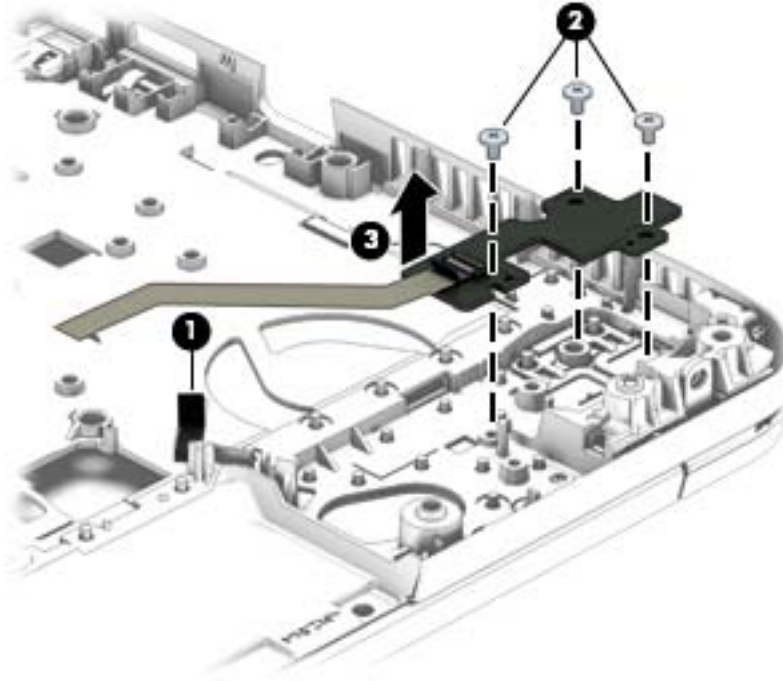

Reverse this procedure to install the function button board.

Processor



NOTE: The processor spare part kit includes replacement thermal material.

Description	Spare part number
Intel Dual Core i7-4600M 2.80-GHz processor (3.0-MB L3 cache, 37 W)	737330-001
Intel Dual Core i5-4330M 2.80-GHz processor (3.0-MB L3 cache, 37 W)	738201-001
Intel Dual Core i5-4300M 2.60-GHz processor (3.0-MB L3 cache, 37 W)	738309-001
Intel Dual Core i5-4200M 2.50-GHz processor (3.0-MB L3 cache, 37 W)	737328-001
Intel Dual Core i3-4100M 2.50-GHz processor (3.0-MB L3 cache, 37 W)	737474-001
Intel Dual Core i3-4000M 2.40-GHz (SC turbo up to 3.30-GHz) processor (1600-MHz FSB, 3.0-MB L3 cache, 37 W)	737327-001
AMD A10-5750M with Radeon HD 8650G Graphics (quad-core; 3.5 GHz/2.5 GHz; 35W, 4 MB L2 cache)	713548-001
AMD A10-4600M with Radeon HD 7660G Graphics (quad-core; 3.2 GHz/2.3 GHz; 35W; 4 MB L2 cache)	683046-001
AMD A8-4500M with Radeon HD 7640G Graphics (quad-core; 2.8 GHz/1.9 GHz; 35W; 4 MB L2 cache)	683048-001
AMD A6-4400M with Radeon HD 7520G Graphics (dual-core; 3.2 GHz/2.7 GHz; 35W; 1 MB L2 cache)	683047-001
A6-5350M with Radeon HD 8450G Graphics (dual-core; 3.5 GHz/2.9 GHz; 35W; 1 MB L2 cache)	713550-001
AMD A4-4300M with Radeon HD 7420G Graphics (dual-core; 3.0 GHz/2.5 GHz; 35W; 1 MB L2 cache)	685990-001
AMD A4-5150M with Radeon HD 8350G Graphics (dual-core; 3.3 GHz/2.7 GHz; 35W; 1 MB L2 cache)	713549-001
AMD A8-5550M 3.1 GHz/2.1 GHz 4M 35W	713551-001

Before removing the processor, follow these steps:

1. Turn off the computer. If you are unsure whether the computer is off or in Hibernation, turn the computer on, and then shut it down through the operating system.
2. Disconnect the power from the computer by unplugging the power cord from the computer.
3. Disconnect all external devices from the computer.
4. Remove the battery (see [Battery on page 63](#)), and then remove the following components:
 - a. Service cover (see [Service cover on page 64](#))
 - b. Hard drive (see [Hard drive on page 65](#))
 - c. Optical drive (see [Optical drive on page 76](#))
 - d. Keyboard (see [Keyboard on page 79](#))
 - e. Base enclosure (see [Base enclosure on page 89](#))
 - f. Fan and heat sink assembly (see [Fan and heat sink assembly on page 85](#))

Remove the processor:

1. Use a Torx8 screw driver to turn the processor locking screw one-half turn counterclockwise **(1)**, until you hear a click.
2. Lift the processor **(2)** straight up, and remove it.

 **NOTE:** The gold triangle **(3)** on the processor must be aligned with the triangle icon embossed on the processor socket **(4)** when you install the processor.

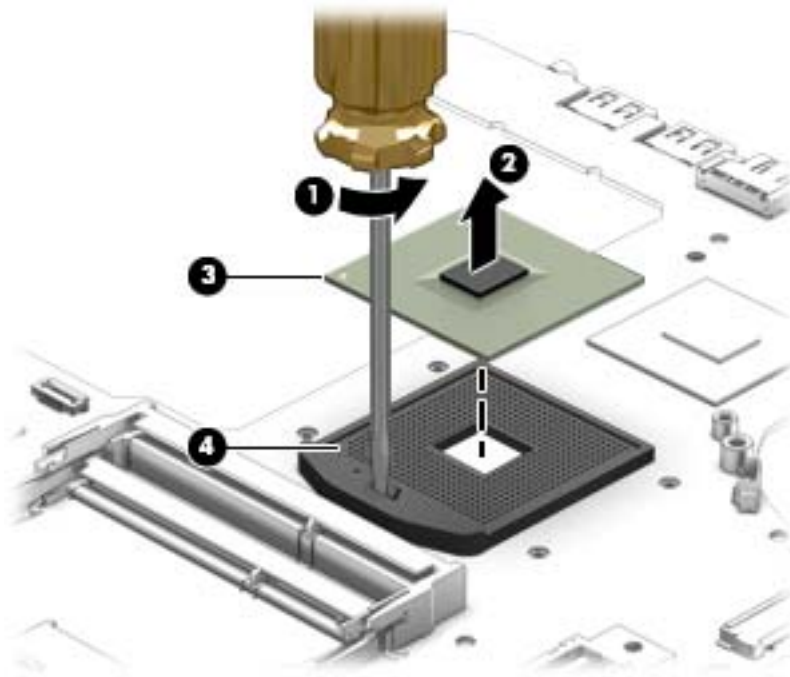

Reverse this procedure to install the processor.

TouchPad

Description	Spare part number
Top cover (includes TouchPad, TouchPad cable, and TouchPad bracket)	
Top cover for 15.6-in models with 2-button TouchPad	745889-001
2-button TouchPad with bracket for 15.6-in models	738710-001
Top cover for 15.6-in models with 4-button TouchPad	745890-001
4-button TouchPad with bracket for 15.6-in models	738711-001
Top cover for 14-in models with 2-button TouchPad	738405-001
2-button TouchPad with bracket for 14-in models	738407-001
Top cover for 14-in models with 4-button TouchPad	738406-001
4-button TouchPad with bracket for 14-in models	738408-001

Before removing the top cover, follow these steps:

1. Turn off the computer. If you are unsure whether the computer is off or in Hibernation, turn the computer on, and then shut it down through the operating system.
2. Disconnect the power from the computer by unplugging the power cord from the computer.
3. Disconnect all external devices from the computer.
4. Remove the battery (see [Battery on page 63](#)), and then remove the following components:
 - a. Service cover (see [Service cover on page 64](#))
 - b. Hard drive (see [Hard drive on page 65](#))
 - c. Optical drive (see [Optical drive on page 76](#))
 - d. Keyboard (see [Keyboard on page 79](#))



NOTE: When replacing the top cover, be sure to remove the following components from the defective top cover and install them on the replacement top cover:

- Function button board (see [Function button board on page 106](#))
- Power button board (see [Power button board on page 94](#))
- Fingerprint reader board (see [Fingerprint reader board on page 96](#))

Remove the TouchPad:

1. Remove the four Torx screws (1) that secure the TouchPad to the top cover.

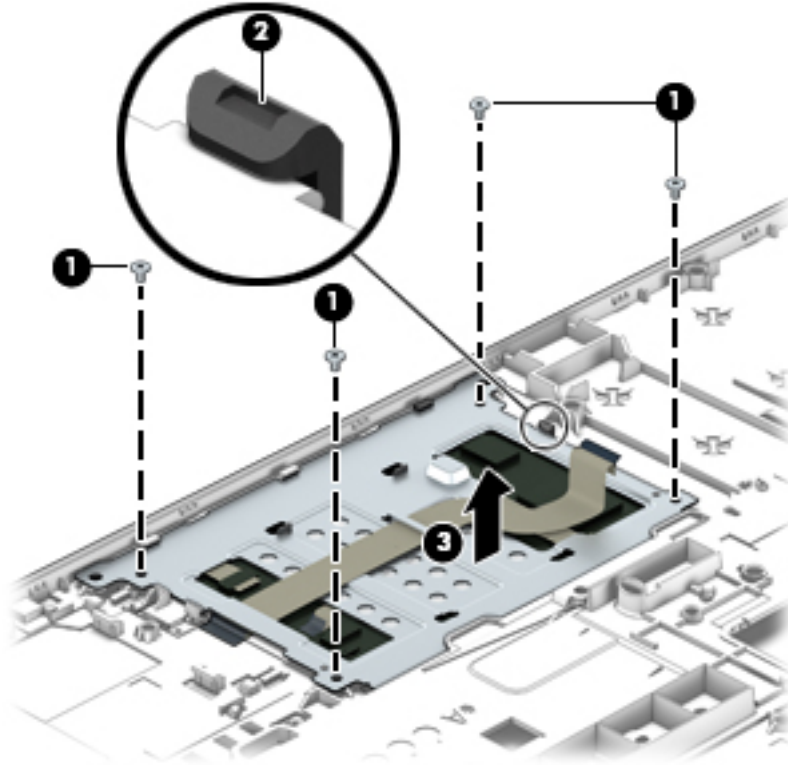

2. Release the clip (2), and then remove the TouchPad (3).

Reverse this procedure to install the TouchPad.

Power connector cable



NOTE: The power connector cable is included in the Cable Kit (see [Cables on page 39](#)).

Before removing the power connector cable, follow these steps:

1. Turn off the computer. If you are unsure whether the computer is off or in Hibernation, turn the computer on, and then shut it down through the operating system.
2. Disconnect the power from the computer by unplugging the power cord from the computer.
3. Disconnect all external devices from the computer.
4. Remove the battery (see [Battery on page 63](#)), and then remove the following components:
 - a. Service cover (see [Service cover on page 64](#))
 - b. Hard drive (see [Hard drive on page 65](#))
 - c. Optical drive (see [Optical drive on page 76](#))
 - d. Keyboard (see [Keyboard on page 79](#))
 - e. Base enclosure (see [Base enclosure on page 89](#))
 - f. USB board (see [USB board on page 92](#))
 - g. Speakers (see [Speakers on page 104](#))
 - h. Fan and heat sink assembly (see [Fan and heat sink assembly on page 85](#))

Remove the power connector cable:

1. Disconnect the power connector cable **(1)** from the system board.
2. Release the power connector cable **(2)** from the clips built into the base enclosure.

3. Release the power connector (3) from the clips and mold built into the base enclosure.

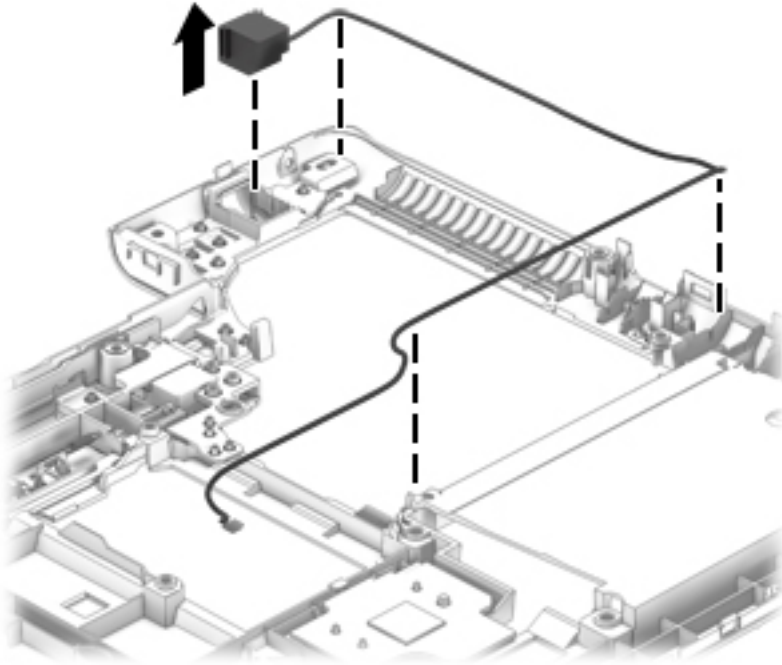

4. Remove the power connector cable.

Reverse this procedure to install the power connector cable.

RTC battery

Description	Spare part number
RTC battery (includes cable and double-sided adhesive)	651948-001

Before removing the RTC battery, follow these steps:

1. Turn off the computer. If you are unsure whether the computer is off or in Hibernation, turn the computer on, and then shut it down through the operating system.
2. Disconnect the power from the computer by unplugging the power cord from the computer.
3. Disconnect all external devices from the computer.
4. Remove the battery (see [Battery on page 63](#)).
5. Remove the service cover (see [Service cover on page 64](#)).

Remove the RTC battery:

1. Disconnect the RTC battery cable (1) from the system board.

2. Detach the RTC battery (2) from the base enclosure. (The RTC battery is attached to the base enclosure with double-sided adhesive.)

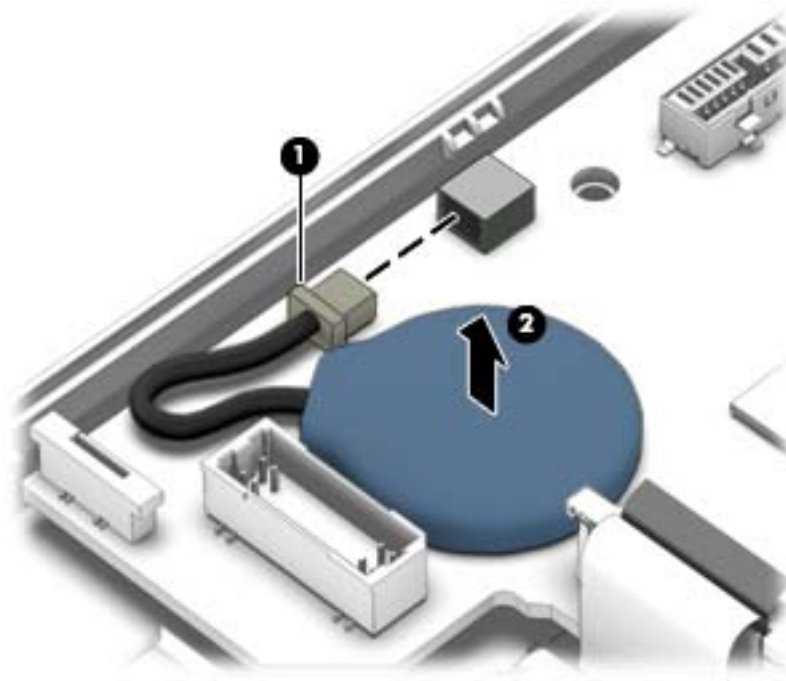

3. Remove the RTC battery and cable.
Reverse this procedure to install the RTC battery.

Display assembly

 **NOTE:** The display assembly is spared as a whole unit assembly only.

Description	Spare part number
15.6-in WLED FHD, UWVA display assembly equipped with a webcam	739998-001
15.6-in WLED HD, UWVA display assembly equipped with a webcam	739997-001
14-in HD AG WLED SVA eDP FLT display panel equipped with a webcam	747751-001
14-in HD+ AG WLED SVA eDP FLT equipped with a webcam	747752-001
14-in FHD AG WLED UWVA eDPslim PSR display assembly equipped with a webcam	747753-001

To remove the display assembly and access the display assembly subcomponents, follow these steps:

1. Turn off the computer. If you are unsure whether the computer is off or in Hibernation, turn the computer on, and then shut it down through the operating system.
2. Disconnect the power from the computer by unplugging the power cord from the computer.
3. Disconnect all external devices from the computer.
4. Remove the battery (see [Battery on page 63](#)).

Remove the display assembly:

1. Open the computer.
2. If it is necessary to replace the display bezel or any of the display assembly subcomponents:
 - a. Flex the inside edges of the top edge (1), the left and right sides (2), and the bottom edge (3) of the display bezel until the bezel disengages from the display enclosure.
 - b. Remove the display bezel (4).

The display bezel is available using spare part numbers 734301-001 (for use only on computer models equipped with a webcam) and 734302-001 (for use only on computer models not equipped with a webcam).

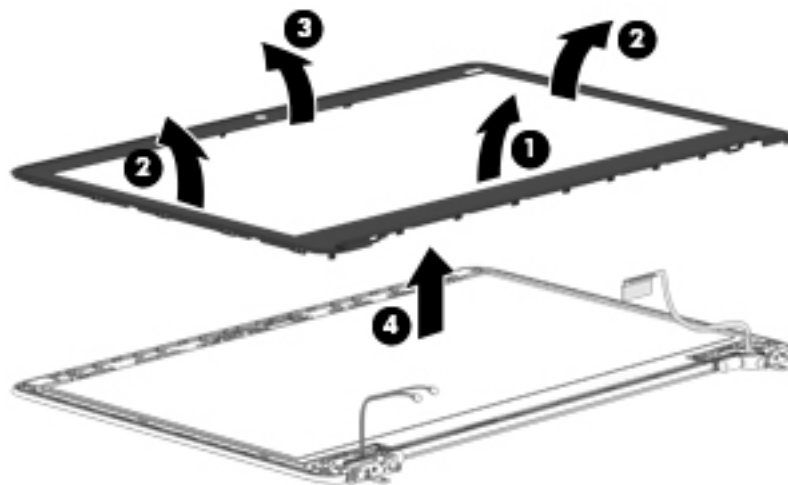

3. If it is necessary to replace the display panel:
 - a. Remove the four Phillips PM2.0×3.0 screws that secure the display panel to the display enclosure.

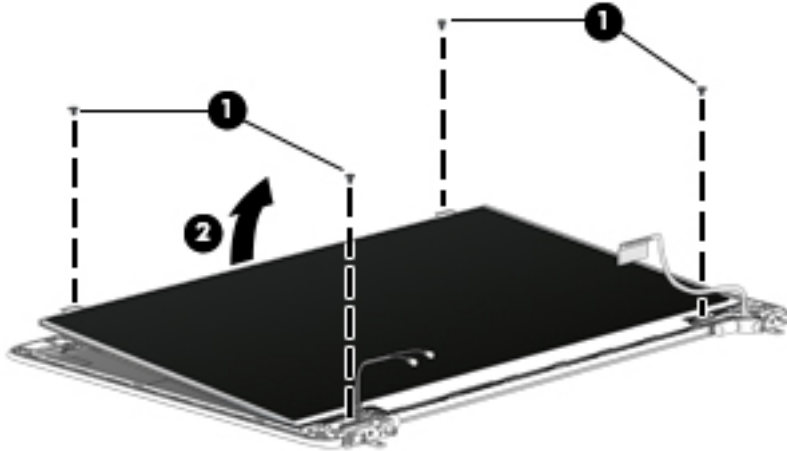

⚠ CAUTION: Before turning the display panel upside down, make sure the work surface is clear of tools, screws, and any other foreign objects. Failure to follow this caution can result in damage to the display panel.

- b. Lift the top edge of the display panel (1) and swing it up and forward until it rests upside down in front of the display enclosure.

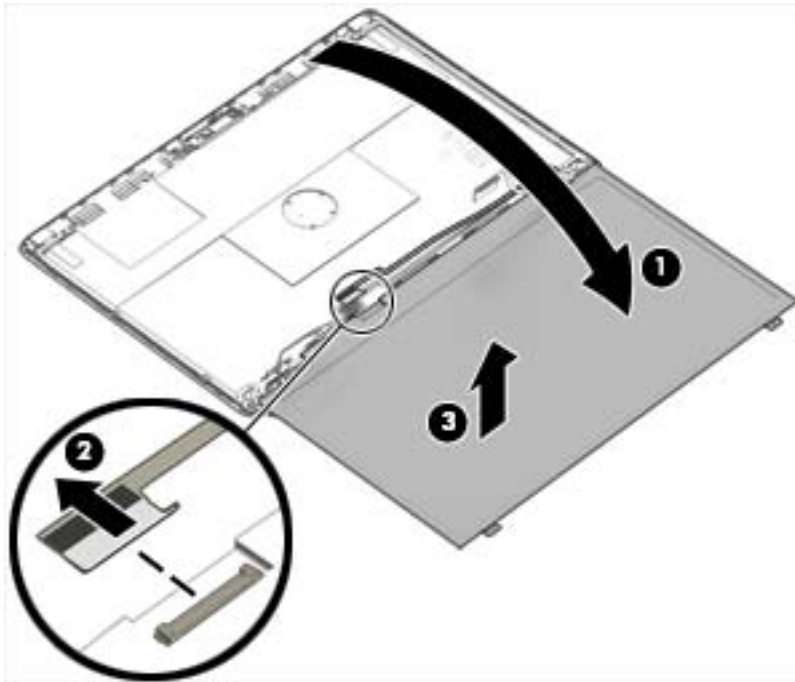

- c. Release the adhesive strip (2) that secures the display panel cable connector to the display panel, and then disconnect the display panel cable from the display panel.
 - d. Remove the display panel.

4. Remove the six Torx T8 screws (1) and the 2 Torx screws that secure the hinge bracket to the computer.

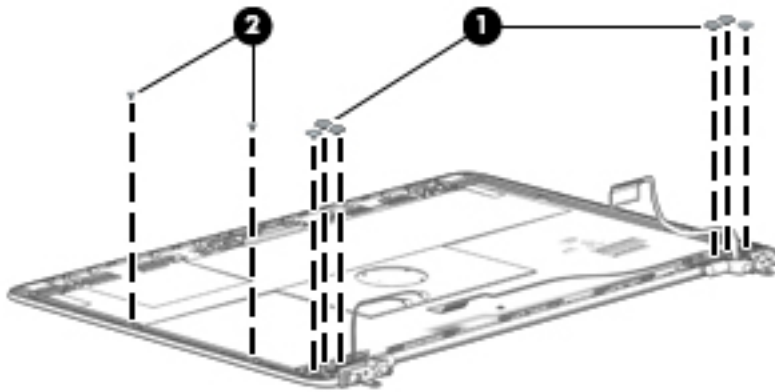

5. Remove the WLAN and WWAN transceiver (1) and the hinge brackets (2).
The hinge bracket is available using spare part number 738699-001.

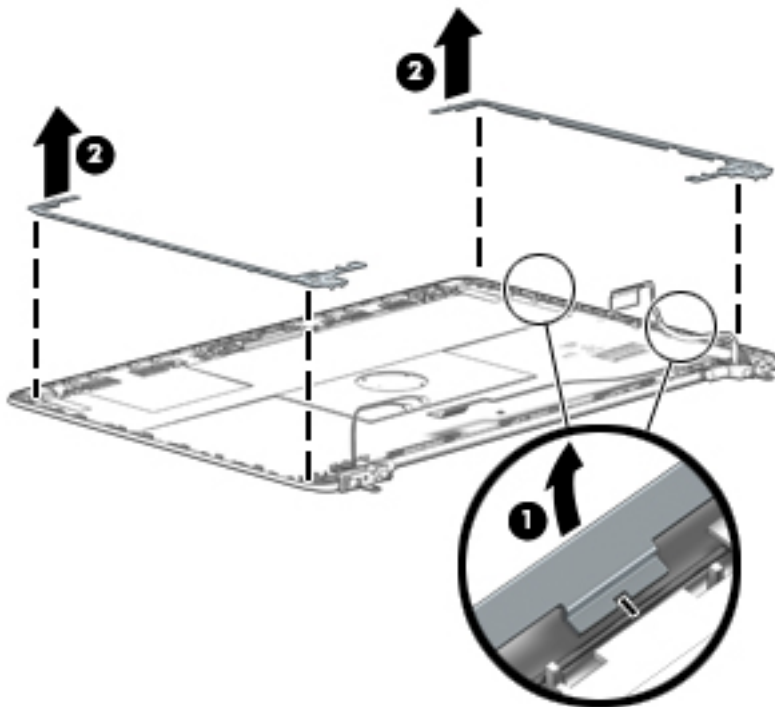

6. Remove the display panel cable and the wireless transceiver.

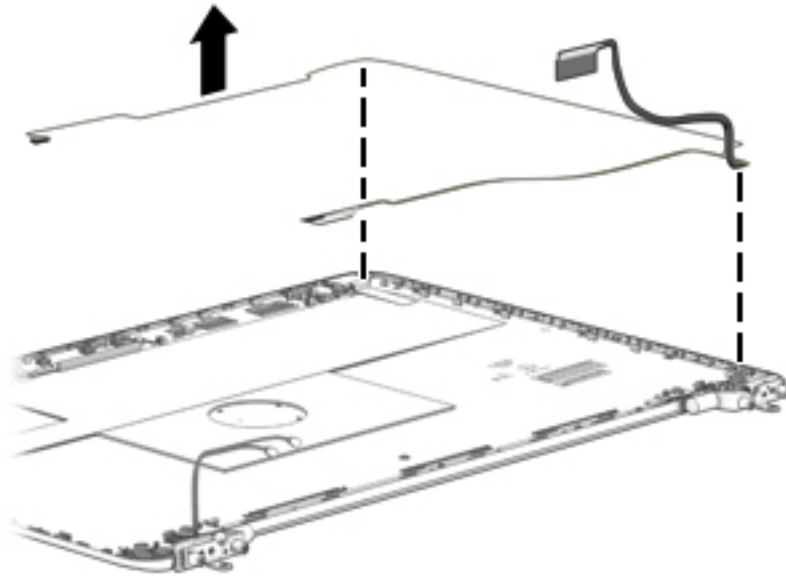

7. If it is necessary to replace the webcamera/microphone module or microphone module:

CAUTION: Handle the webcamera/microphone module and microphone module with caution. These modules have a thin profile and are susceptible to damage when not handled carefully.

- a. Disconnect the webcamera/microphone module cable **(1)** from the webcamera/microphone module.

- b. Detach the webcam/microphone module (2) from the display enclosure. (The webcam/microphone module is attached to the display enclosure with double-sided adhesive.)

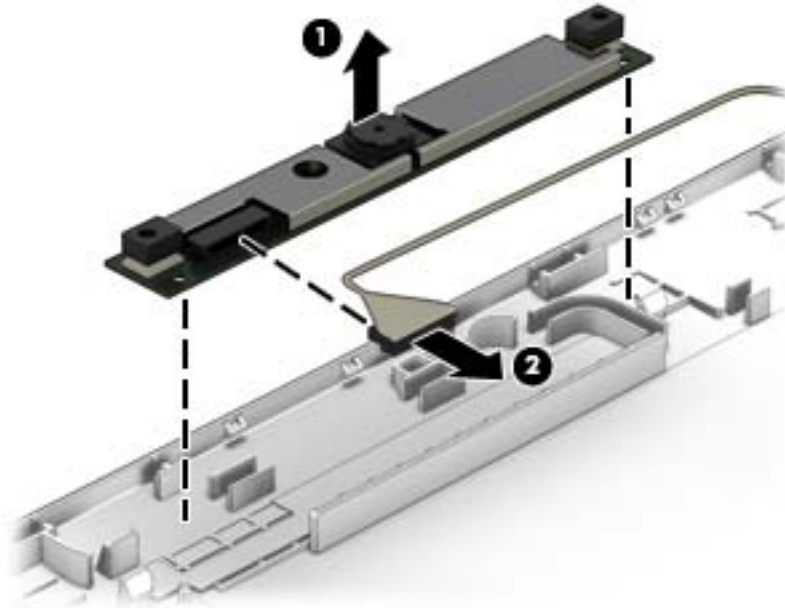

- c. Remove the webcam/microphone module.

The webcam/microphone module is available using spare part number 738409-001. The microphone module is available using spare part number 738397-001.

Reverse this procedure to reassemble and install the display assembly.

7 Computer Setup

Windows 8 — Computer Setup (BIOS), MultiBoot, and System Diagnostics

Using Computer Setup

Computer Setup, or Basic Input/Output System (BIOS), controls communication between all the input and output devices on the system (such as disk drives, display, keyboard, mouse, and printer). Computer Setup includes settings for the types of devices installed, the startup sequence of the computer, and the amount of system and extended memory.

 **NOTE:** Use extreme care when making changes in Computer Setup. Errors can prevent the computer from operating properly.

Starting Computer Setup

 **NOTE:** An external keyboard or mouse connected to a USB port can be used with Computer Setup only if USB legacy support is enabled.

To start Computer Setup, follow these steps:

1. Turn on or restart the computer, and then press **esc** while the “press the ESC key for Startup Menu” message is displayed at the bottom of the screen.
2. press **f10** to enter Computer Setup.

Navigating and selecting in Computer Setup

To navigate and select in Computer Setup, follow these steps:

1. Turn on or restart the computer, and then press **esc** while the “press the ESC key for Startup Menu” message is displayed at the bottom of the screen.

 **NOTE:** You can use either a pointing device (TouchPad, pointing stick, or USB mouse) or the keyboard to navigate and make selections in Computer Setup.

2. press **f10** to enter Computer Setup.
 - To select a menu or a menu item, use the tab key and the keyboard arrow keys and then press enter, or use a pointing device to click the item.
 - To scroll up and down, click the up arrow or the down arrow in the upper-right corner of the screen, or use the up arrow key or the down arrow key on the keyboard.
 - To close open dialog boxes and return to the main Computer Setup screen, press **esc**, and then follow the on-screen instructions.

To exit Computer Setup menus, choose one of the following methods:

- To exit Computer Setup menus without saving your changes:
Click the **Exit** icon in the lower-right corner of the screen, and then follow the on-screen instructions.
– or –
Use the tab key and the arrow keys to select **Main > Ignore Changes and Exit**, and then press [enter](#).
- To save your changes and exit Computer Setup menus:
Click the **Save** icon in the lower-right corner of the screen, and then follow the on-screen instructions.
– or –
Use the tab key and the arrow keys to select **Main > Save Changes and Exit**, and then press [enter](#).

Your changes go into effect when the computer restarts.

Restoring default settings in Computer Setup

 **NOTE:** Restoring default will not change the hard drive mode.

To return all settings in Computer Setup to the values that were set at the factory, follow these steps:

1. Turn on or restart the computer, and then press [esc](#) while the “press the ESC key for Startup Menu” message is displayed at the bottom of the screen.
2. press [f10](#) to enter Computer Setup.
3. Use a pointing device or the arrow keys to select **Main > Restore Defaults**.
4. Follow the on-screen instructions.
5. To save your changes and exit, click the **Save** icon in the lower-right corner of the screen, and then follow the on-screen instructions.

– or –

Use the arrow keys to select **Main > Save Changes and Exit**, and then press [enter](#).

Your changes go into effect when the computer restarts.

 **NOTE:** Your password settings and security settings are not changed when you restore the default settings.

Updating the BIOS

Updated versions of the BIOS may be available on the HP website.

Most BIOS updates on the HP website are packaged in compressed files called *SoftPaqs*.

Some download packages contain a file named Readme.txt, which contains information regarding installing and troubleshooting the file.

Determining the BIOS version

To determine whether available BIOS updates contain later BIOS versions than those currently installed on the computer, you need to know the version of the system BIOS currently installed.

BIOS version information (also known as *ROM date* and *System BIOS*) can be displayed by pressing **fn+esc** (if you are already in Windows) or by using Computer Setup.

1. Start Computer Setup.
2. Use a pointing device or the arrow keys to select **Main > System Information**.
3. To exit Computer Setup without saving your changes, click the **Exit** icon in the lower-right corner of the screen, and then follow the on-screen instructions.

– or –

Use the tab key and the arrow keys to select **Main > Ignore Changes and Exit**, and then press **enter**.

Downloading a BIOS update

 **CAUTION:** To reduce the risk of damage to the computer or an unsuccessful installation, download and install a BIOS update only when the computer is connected to reliable external power using the AC adapter. Do not download or install a BIOS update while the computer is running on battery power, docked in an optional docking device, or connected to an optional power source. During the download and installation, follow these instructions:

Do not disconnect power on the computer by unplugging the power cord from the AC outlet.

Do not shut down the computer or initiate Sleep.

Do not insert, remove, connect, or disconnect any device, cable, or cord.

1. Access the HP website, <http://www.hp.com>.
2. Select **Support**, and then select **Download drivers**.
3. Enter the product name in the text box, and then select **Go**.
4. Select your computer model, and then select your operating system.
5. In the BIOS section, follow these steps:
 - a. Identify the most recent BIOS update and compare it to the BIOS version currently installed on your computer. Make a note of the date, name, or other identifier. You may need this information to locate the update later, after it has been downloaded to your hard drive.
 - b. Follow the on-screen instructions to download your selection to the hard drive. If the update is more recent than your BIOS, make a note of the path to the location on your hard drive where the BIOS update is downloaded. You will need to access this path when you are ready to install the update.

 **NOTE:** If you connect your computer to a network, consult the network administrator before installing any software updates, especially system BIOS updates.

BIOS installation procedures vary. Follow any instructions that are displayed on the screen after the download is complete. If no instructions are displayed, follow these steps:

1. From the Start screen, type **e**, and then click **File Explorer**.
2. Click your hard drive designation. The hard drive designation is typically Local Disk (C:).
3. Using the hard drive path you recorded earlier, open the folder on your hard drive that contains the update.

4. Double-click the file that has an .exe extension (for example, *filename.exe*).
The BIOS installation begins.
5. Complete the installation by following the on-screen instructions.

 **NOTE:** After a message on the screen reports a successful installation, you can delete the downloaded file from your hard drive.

Using MultiBoot

About the boot device order

As the computer starts, the system attempts to boot from enabled devices. The MultiBoot utility, which is enabled at the factory, controls the order in which the system selects a boot device. Boot devices can include optical drives, diskette drives, a network interface card (NIC), hard drives, and USB devices. Boot devices contain bootable media or files that the computer needs to start and operate properly.

 **NOTE:** Some boot devices must be enabled in Computer Setup before they can be included in the boot order.

You can change the order in which the computer searches for a boot device by changing the boot order in Computer Setup. You can also press **esc** while the “press the ESC key for Startup Menu” message is displayed at the bottom of the screen, and then press **f9**. Pressing **f9** displays a menu that shows the current boot devices and allows you to select a boot device. Or, you can use MultiBoot Express to set the computer to prompt you for a boot location each time the computer turns on or restarts.

Choosing MultiBoot preferences

You can use MultiBoot in the following ways:

- To set a new boot order that the computer uses each time it is turned on, by changing the boot order in Computer Setup.
- To dynamically choose the boot device, by pressing **esc** while the “press the ESC key for Startup Menu” message is displayed at the bottom of the screen, and then pressing **f9** to enter the Boot Device Options menu.
- To use MultiBoot Express to set variable boot orders. This feature prompts you for a boot device each time the computer is turned on or restarted.

Setting a new boot order in Computer Setup

To start Computer Setup and set a boot device order that the computer uses each time it is turned on or restarted, follow these steps:

1. Turn on or restart the computer, and then press **esc** while the “press the ESC key for Startup Menu” message is displayed at the bottom of the screen.
2. press **f10** to enter Computer Setup.
3. Use a pointing device or the arrow keys to select **Advanced > Boot Options > UEFI Boot Order for UEFI Hybrid or UEFI Native Boot Mode** or select **Advanced > Boot Options > Legacy Boot Order for Legacy Boot Mode**, and then press **enter**.
4. To move the device up in the boot order, use a pointing device to click the up arrow, or press the **+** key.

– or –

To move the device down in the boot order, use a pointing device to click the down arrow, or press the **-** key.

5. To save your changes and exit Computer Setup, click the **Save** icon in the lower-left corner of the screen, and then follow the on-screen instructions.

– or –

Use the arrow keys to select **Main > Save Changes and Exit**, and then press **enter**.

Dynamically choosing a boot device using the f9 prompt

To dynamically choose a boot device for the current startup sequence, follow these steps:

1. Open the Select Boot Device menu by turning on or restarting the computer, and then pressing **esc** while the “press the ESC key for Startup Menu” message is displayed at the bottom of the screen.
2. press **f9**.
3. Use a pointing device or the arrow keys to select a boot device, and then press **enter**.

Setting a MultiBoot Express prompt

To start Computer Setup and set the computer to display the MultiBoot startup location menu each time the computer is started or restarted, follow these steps:

1. Turn on or restart the computer, and then press **esc** while the “press the ESC key for Startup Menu” message is displayed at the bottom of the screen.
2. press **f10** to enter Computer Setup.
3. Use a pointing device or the arrow keys to select **Advanced > Boot Options > MultiBoot Express Boot Popup Delay (Sec)**, and then press **enter**.
4. In the **MultiBoot Express Boot Popup Delay (Sec)** field, enter the length of time in seconds that you want the computer to display the startup location menu before it defaults to the current MultiBoot setting. (When 0 is selected, the Express Boot startup location menu is not displayed.)
5. To save your changes and exit Computer Setup, click the **Save** icon in the lower-left corner of the screen, and then follow the on-screen instructions.

– or –

Use the arrow keys to select **Main > Save Changes and Exit**, and then press **enter**.

Your changes go into effect when the computer restarts.

Entering MultiBoot Express preferences

When the Express Boot menu is displayed during startup, you have the following choices:

- To specify a boot device from the Express Boot menu, select your preference within the allotted time, and then press **enter**.
- To prevent the computer from defaulting to the current MultiBoot setting, press any key before the allotted time expires. the computer will not start until you select a boot device and press **enter**.
- To allow the computer to start according to the current MultiBoot settings, wait for the allotted time to expire.

Using HP PC Hardware Diagnostics (UEFI) (select models only)

HP PC Hardware Diagnostics is a Unified Extensible Firmware Interface (UEFI) that allows you to run diagnostic tests to determine if the computer hardware is functioning properly. The tool runs outside of the operating system to isolate hardware failures from issues that may be caused by the operating system or other software components.

To start System Diagnostics:

1. Turn on or restart the computer, quickly press **esc**, and then press **f2**.

After pressing **f2**, the BIOS searches three places for the HP PC Hardware Diagnostics (UEFI) tools in the following order:

- a. Connected USB drive

 **NOTE:** To download the HP PC Hardware Diagnostics (UEFI) tool to a USB drive, see .

- b. Hard drive
- c. BIOS

2. Click the type of diagnostic test you want to run, and then follow the on-screen instructions.

 **NOTE:** If you need to stop a diagnostics test while it is running, press **esc**.

Downloading HP PC Hardware Diagnostics (UEFI) to a USB device

 **NOTE:** The HP PC Hardware Diagnostics (UEFI) download instructions are provided in English only.

1. Go to <http://www.hp.com>.
2. Select **Support**, and then select **Download drivers**.
3. Enter the product name in the text box, and then click **Search**.
4. Select your computer model, and then select your operating system.
5. In the Diagnostic section, click **HP UEFI Support Environment**.

– or –

Select **Download**, and then select **Run**.

Windows 7 — Computer Setup (BIOS), MultiBoot, and HP PC Hardware Diagnostics (UEFI)

Using Computer Setup

Computer Setup, or Basic Input/Output System (BIOS), controls communication between all the input and output devices on the system (such as disk drives, display, keyboard, mouse, and printer). Computer Setup includes settings for the types of devices installed, the startup sequence of the computer, and the amount of system and extended memory.

 **NOTE:** Use extreme care when making changes in Computer Setup. Errors can prevent the computer from operating properly.

Starting Computer Setup



NOTE: An external keyboard or mouse connected to a USB port can be used with Computer Setup only if USB legacy support is enabled.

To start Computer Setup, follow these steps:

1. Turn on or restart the computer, and then press **esc** while the “press the ESC key for Startup Menu” message is displayed at the bottom of the screen.
2. press **f10** to enter Computer Setup.

Navigating and selecting in Computer Setup

To navigate and select in Computer Setup, follow these steps:

1. Turn on or restart the computer, and then press **esc** while the “press the ESC key for Startup Menu” message is displayed at the bottom of the screen.



NOTE: You can use either a pointing device (TouchPad, pointing stick, or USB mouse) or the keyboard to navigate and make selections in Computer Setup.

2. press **f10** to enter Computer Setup.
 - To select a menu or a menu item, use the **tab** key and the keyboard arrow keys and then press **enter**, or use a pointing device to click the item.
 - To scroll up and down, click the up arrow or the down arrow in the upper-right corner of the screen, or use the up arrow key or the down arrow key on the keyboard.
 - To close open dialog boxes and return to the main Computer Setup screen, press **esc**, and then follow the on-screen instructions.

To exit Computer Setup menus, choose one of the following methods:

- To exit Computer Setup menus without saving your changes:

Click the **Exit** icon in the lower-right corner of the screen, and then follow the on-screen instructions.

– or –

Use the **tab** key and the arrow keys to select **Main > Ignore Changes and Exit**, and then press **enter**.
- To save your changes and exit Computer Setup menus:

Click the **Save** icon in the lower-right corner of the screen, and then follow the on-screen instructions.

– or –

Use the **tab** key and the arrow keys to select **Main > Save Changes and Exit**, and then press **enter**.

Your changes go into effect when the computer restarts.

Restoring factory settings in Computer Setup



NOTE: Restoring defaults will not change the hard drive mode.

To return all settings in Computer Setup to the values that were set at the factory, follow these steps:

1. Turn on or restart the computer, and then press **esc** while the “press the ESC key for Startup Menu” message is displayed at the bottom of the screen.
2. press **f10** to enter Computer Setup.
3. Use a pointing device or the arrow keys to select **Main > Restore Defaults**.
4. Follow the on-screen instructions.
5. To save your changes and exit, click the **Save** icon in the lower-right corner of the screen, and then follow the on-screen instructions.

– or –

Use the arrow keys to select **Main > Save Changes and Exit**, and then press **enter**.

Your changes go into effect when the computer restarts.



NOTE: Your password settings and security settings are not changed when you restore the default settings.

Updating the BIOS

Updated versions of the BIOS may be available on the HP website.

Most BIOS updates on the HP website are packaged in compressed files called *SoftPaqs*.

Some download packages contain a file named *Readme.txt*, which contains information regarding installing and troubleshooting the file.

Determining the BIOS version

To determine whether available BIOS updates contain later BIOS versions than those currently installed on the computer, you need to know the version of the system BIOS currently installed.

BIOS version information (also known as *ROM date* and *System BIOS*) can be displayed by pressing **fn+esc** (if you are already in Windows) or by using Computer Setup.

1. Start Computer Setup.
2. Use a pointing device or the arrow keys to select **Main > System Information**.
3. To exit Computer Setup without saving your changes, click the **Exit** icon in the lower-right corner of the screen, and then follow the on-screen instructions.

– or –

Use the **tab** key and the arrow keys to select **Main > Ignore Changes and Exit**, and then press **enter**.

Downloading a BIOS update

 **CAUTION:** CAUTION: To reduce the risk of damage to the computer or an unsuccessful installation, download and install a BIOS update only when the computer is connected to reliable external power using the AC adapter. Do not download or install a BIOS update while the computer is running on battery power, docked in an optional docking device, or connected to an optional power source. During the download and installation, follow these instructions:

Do not disconnect power on the computer by unplugging the power cord from the AC outlet.

Do not shut down the computer or initiate Sleep.

Do not insert, remove, connect, or disconnect any device, cable, or cord.

1. Access the HP website, <http://www.hp.com>.
2. Click **Support**, and then select **Download drivers**.
3. Enter the product name in the text box, and then click **Go**.
4. Select your computer model, and then select your operating system.
5. In the BIOS section, follow these steps:
 - a. Identify the most recent BIOS update and compare it to the BIOS version currently installed on your computer. Make a note of the date, name, or other identifier. You may need this information to locate the update later, after it has been downloaded to your hard drive.
 - b. Follow the on-screen instructions to download your selection to the hard drive. If the update is more recent than your BIOS, make a note of the path to the location on your hard drive where the BIOS update is downloaded. You will need to access this path when you are ready to install the update.



NOTE: If you connect your computer to a network, consult the network administrator before installing any software updates, especially system BIOS updates.

BIOS installation procedures vary. Follow any instructions that are displayed on the screen after the download is complete. If no instructions are displayed, follow these steps:

1. Select **Start > Computer**.
2. Click your hard drive designation. The hard drive designation is typically Local Disk (C:).
3. Using the hard drive path you recorded earlier, open the folder on your hard drive that contains the update.
4. Double-click the file that has an .exe extension (for example, *filename.exe*). The BIOS installation begins.
5. Complete the installation by following the on-screen instructions.



NOTE: After a message on the screen reports a successful installation, you can delete the downloaded file from your hard drive.

Using MultiBoot

About the boot device order

As the computer starts, the system attempts to boot from enabled devices. The MultiBoot utility, which is enabled at the factory, controls the order in which the system selects a boot device. Boot devices can include optical drives, diskette drives, a network interface card (NIC), hard drives, and USB devices. Boot devices contain bootable media or files that the computer needs to start and operate properly.



NOTE: Some boot devices must be enabled in Computer Setup before they can be included in the boot order.

You can change the order in which the computer searches for a boot device by changing the boot order in Computer Setup. You can also press **esc** while the “press the ESC key for Startup Menu” message is displayed at the bottom of the screen, and then press **f9**. Pressing **f9** displays a menu that shows the current boot devices and allows you to select a boot device. Or, you can use MultiBoot Express to set the computer to prompt you for a boot location each time the computer turns on or restarts.

Choosing MultiBoot preferences

You can use MultiBoot in the following ways:

- To set a new boot order that the computer uses each time it is turned on, by changing the boot order in Computer Setup.
- To dynamically choose the boot device, by pressing **esc** while the “press the ESC key for Startup Menu” message is displayed at the bottom of the screen, and then pressing **f9** to enter the Boot Device Options menu.
- To use MultiBoot Express to set variable boot orders. This feature prompts you for a boot device each time the computer is turned on or restarted.

Setting a new boot order in Computer Setup

To start Computer Setup and set a boot device order that the computer uses each time it is turned on or restarted, follow these steps:

1. Turn on or restart the computer, and then press **esc** while the “press the ESC key for Startup Menu” message is displayed at the bottom of the screen.
2. press **f10** to enter Computer Setup.
3. Use a pointing device or the arrow keys to select **Advanced > Boot Options > UEFI Boot Order for UEFI Hybrid or UEFI Native Boot Mode** or select **Advanced > Boot Options > Legacy Boot Order for Legacy Boot Mode**, and then press **enter**.
4. To move the device up in the boot order, use a pointing device to click the up arrow, or press the **+** key.

– or –

To move the device down in the boot order, use a pointing device to click the down arrow, or press the **-** key.

5. To save your changes and exit Computer Setup, click the **Save** icon in the lower-left corner of the screen, and then follow the on-screen instructions.

– or –

Use the arrow keys to select **Main > Save Changes and Exit**, and then press **enter**.

Dynamically choosing a boot device using the f9 prompt

To dynamically choose a boot device for the current startup sequence, follow these steps:

1. Open the Select Boot Device menu by turning on or restarting the computer, and then pressing **esc** while the “press the ESC key for Startup Menu” message is displayed at the bottom of the screen.
2. press **f9**.
3. Use a pointing device or the arrow keys to select a boot device, and then press **enter**.

Setting a MultiBoot Express prompt

To start Computer Setup and set the computer to display the MultiBoot startup location menu each time the computer is started or restarted, follow these steps:

1. Turn on or restart the computer, and then press **esc** while the “press the ESC key for Startup Menu” message is displayed at the bottom of the screen.
2. press **f10** to enter Computer Setup.
3. Use a pointing device or the arrow keys to select **Advanced > Boot Options > MultiBoot Express Boot Popup Delay (Sec)**, and then press **enter**.
4. In the **MultiBoot Express Boot Popup Delay (Sec)** field, enter the length of time in seconds that you want the computer to display the startup location menu before it defaults to the current MultiBoot setting. (When 0 is selected, the Express Boot startup location menu is not displayed.)
5. To save your changes and exit Computer Setup, click the **Save** icon in the lower-left corner of the screen, and then follow the on-screen instructions.

– or –

Use the arrow keys to select **Main > Save Changes and Exit**, and then press **enter**.

Entering MultiBoot Express preferences

When the Express Boot menu is displayed during startup, you have the following choices:

- To specify a boot device from the Express Boot menu, select your preference within the allotted time, and then press [enter](#).
- To prevent the computer from defaulting to the current MultiBoot setting, press any key before the allotted time expires. The computer will not start until you select a boot device and press [enter](#).
- To allow the computer to start according to the current MultiBoot settings, wait for the allotted time to expire.

Using HP PC Hardware Diagnostics (UEFI) (select models only)

HP PC Hardware Diagnostics is a Unified Extensible Firmware Interface (UEFI) that allows you to run diagnostic tests to determine if the computer hardware is functioning properly. The tool runs outside of the operating system to isolate hardware failures from issues that may be caused by the operating system or other software components.

To start HP PC Hardware Diagnostics UEFI:

1. Turn on or restart the computer, quickly press **esc**, and then press **f2**.

After pressing **f2**, the BIOS searches three places for the HP PC Hardware Diagnostics (UEFI) tools in the following order:

- a. Connected USB drive

 **NOTE:** To download the HP PC Hardware Diagnostics (UEFI) tool to a USB drive, see [Downloading HP PC Hardware Diagnostics \(UEFI\) to a USB device on page 132](#).

- b. Hard drive
- c. BIOS

2. Click the type of diagnostic test you want to run, and then follow the on-screen instructions.

 **NOTE:** If you need to stop a diagnostic test while it is running, press **esc**.

Downloading HP PC Hardware Diagnostics (UEFI) to a USB device

 **NOTE:** The HP PC Hardware Diagnostics (UEFI) download instructions are provided in English only.

1. Go to <http://www.hp.com>.
2. Click **Support**, and then click **Download drivers**.
3. Enter the product name in the text box, and then click **Search**.
4. Select your computer model, and then select your operating system.
5. In the Diagnostic section, click **HP UEFI Support Environment**.

– or –

Click **Download**, and then select **Run**.

8 Specifications

Computer specifications

	Metric	U.S.
Dimensions		
Width	37.8 cm	14.88 in
Depth	25.7 cm	10.12 in
Height (front to rear, display assembly)	2.53 cm	0.99 in
Height (front to rear, LED display assembly)	2.9	1.14 in
Weight (computer equipped with 9-cell battery, ODD weight saver, UMA, no FPR, 1 SODIMM, WLAN only, SSD, touchpad only, no camera, no WWAN)	2.5 kg	5.51 lb
Weight (computer equipped with 3-cell battery, ODD weight saver, UMA, no FPR, 1 SODIMM, WLAN only, SSD, touchpad only, no camera, no WWAN)	2.32 kg	5.10 lb
Input power		
Operating voltage and current	19.5 V dc @ 3.33 A – 65 W, Smart AC Adapter (select models only)	
	119.5 V dc @ 4.62 A – 90 W, Smart AC Adapter (select models only)	
Temperature		
Operating	5°C to 35°C	41°F to 95°F
Nonoperating	-20°C to 60°C	-4°F to 140°F
Relative humidity (non-condensing)		
Operating	10% to 90%	
Nonoperating	5% to 95%	
Maximum altitude (unpressurized)		
Operating	-15 m to 3,048 m	-50 ft to 10,000 ft
Nonoperating	-15 m to 12,192 m	-50 ft to 40,000 ft
NOTE: Applicable product safety standards specify thermal limits for plastic surfaces. The device operates well within this range of temperatures.		

Hard drive specifications

	1-TB, 5400-rpm*	750-GB, 5400-rpm**	500-GB, 5400-rpm**
Dimensions			

	1-TB, 5400-rpm*	750-GB, 5400-rpm**	500-GB, 5400-rpm**
Height	9.5 mm	9.5 mm	9.5 mm
Length	100.4 mm	100.4 mm	100.4 mm
Width	69.9 mm	69.9 mm	69.9 mm
Weight	110 g	110 g	110 g
Interface type	SATA	SATA	SATA
Transfer rate			
Synchronous (maximum)	1.1 GB/sec	1.1 GB/sec	1.1 GB/sec
Security	ATA security	ATA security	ATA security
Seek times (typical read, including setting)			
Single track	1.5 ms	1.5 ms	1.5 ms
Average (read/write)	11/13 ms	11/13 ms	11/13 ms
Maximum	22 ms	22 ms	22 ms
Logical blocks	1,953,525,168	1,465,149,168	976,766,112
Disk rotational speed	5400 rpm		
Operating temperature	0°C to 60°C (32°F to 140°F)		
*1 TB = 1 trillion bytes when referring to hard drive storage capacity. Actual accessible capacity is less.			
**1 GB = 1 billion bytes when referring to hard drive storage capacity. Actual accessible capacity is less.			
NOTE: Certain restrictions and exclusions apply. Contact technical support for details.			

Hard drive specifications (continued)

	500-GB, 5400-rpm**	320-GB, 5400-rpm**
Dimensions		
Height	9.5 mm	9.5 mm
Length	100.4 mm	100.4 mm
Width	69.9 mm	69.9 mm
Weight	110 g	110 g
Interface type	SATA	SATA
Transfer rate		
Synchronous (maximum)	1.1 GB/sec	1.1 GB/sec
Security	ATA security	ATA security
Seek times (typical read, including setting)		
1.5 ms	1.5 ms	1.5 ms
11/13 ms	11/13 ms	11/13 ms

	500-GB, 5400-rpm**	320-GB, 5400-rpm**
22 ms	22 ms	22 ms
Single track	1.5 ms	1.5 ms
Average (read/write)	11/13 ms	11/13 ms
Maximum	22 ms	22 ms
Logical blocks	976,773,168	628,142,448
Disk rotational speed	5400 rpm	
Operating temperature	0°C to 60°C (32°F to 140°F)	

*1 TB = 1 trillion bytes when referring to hard drive storage capacity. Actual accessible capacity is less.

**1 GB = 1 billion bytes when referring to hard drive storage capacity. Actual accessible capacity is less.

NOTE: Certain restrictions and exclusions apply. Contact technical support for details.

9 Backup and recovery

Windows 8

To protect your information, use Windows backup and restore utilities to back up individual files and folders, back up your entire hard drive, create system repair media (select models only) by using the installed optical drive (select models only) or an optional external optical drive, or create system restore points. In case of system failure, you can use the backup files to restore the contents of your computer.

From the Start screen, type `restore`, click **Settings**, and then select from the list of displayed options.

 **NOTE:** For detailed instructions on various backup and restore options, perform a search for these topics in Windows Help and Support.

In case of system instability, HP recommends that you print the recovery procedures and save them for later use.

 **NOTE:** Windows includes the User Account Control feature to improve the security of your computer. You may be prompted for your permission or password for tasks such as installing software, running utilities, or changing Windows settings. For more information, see Windows Help and Support.

Backing up your information

Recovery after a system failure is as good as your most recent backup. You should create system repair media and your initial backup immediately after initial system setup. As you add new software and data files, you should continue to back up your system on a regular basis to maintain a reasonably current backup. The system repair media (select models only) are used to start up (boot) the computer and repair the operating system in case of system instability or failure. Your initial and subsequent backups allow you to restore your data and settings if a failure occurs.

For more information on the Windows backup features, see Windows Help and Support.

Performing a system recovery

In case of system failure or instability, the computer provides the following tools to recover your files:

- Windows recovery tools: You can use Windows Backup and Restore to recover information you have previously backed up. You can also use Windows Automatic Repair to fix problems that might prevent Windows from starting correctly.
- **f11** recovery tools: You can use the **f11** recovery tools to recover your original hard drive image. The image includes the Windows operating system and software programs installed at the factory.

 **NOTE:** If you are unable to boot (start up) your computer and you cannot use the system repair media you previously created (select models only), you must purchase Windows operating system media to reboot the computer and repair the operating system. For additional information, see [Using Windows operating system media \(purchased separately\) on page 138](#).

Using the Windows recovery tools

To recover information you previously backed up, see Windows Help and Support for steps on restoring files and folders.

To recover your information using Automatic Repair, follow these steps:

 **CAUTION:** Some Startup Repair options will completely erase and reformat the hard drive. All files you have created and any software installed on the computer are permanently removed. When reformatting is complete, the recovery process restores the operating system, as well as the drivers, software, and utilities from the backup used for recovery.

1. If possible, back up all personal files.
2. If possible, check for the presence of the Recovery Image partition and the Windows partition.

From the Start screen, type `file`, and then click **File Explorer**.

– or –

From the Start screen, type `pc`, and then select **This PC**.

 **NOTE:** If the Windows partition and the Recovery Image partition are not listed, you must recover your operating system and programs using the Windows operating system DVD and the *Driver Recovery* media (both purchased separately). For additional information, see [Using Windows operating system media \(purchased separately\) on page 138](#).

3. If the Windows partition and the Recovery Image partition are listed, restart the computer by pressing and holding the `shift` key while clicking **Restart**.
4. Select **Troubleshoot**, select **Advanced Options**, and then select **Startup Repair**.
5. Follow the on-screen instructions.

 **NOTE:** For additional information on recovering information using the Windows tools, perform a search for these topics in Windows Help and Support.

Using f11 recovery tools

 **CAUTION:** Using `f11` completely erases hard drive contents and reformats the hard drive. All files that you have created and any software that you have installed on the computer are permanently removed. The `f11` recovery tool reinstalls the operating system and HP programs and drivers that were installed at the factory. Software not installed at the factory must be reinstalled.

To recover the original hard drive image using `f11`:

1. If possible, back up all personal files.
2. If possible, check for the presence of the Recovery Image partition: From the Start screen, type `pc`, and then select **This PC**.

 **NOTE:** If the Recovery Image partition is not listed, you must recover your operating system and programs using the Windows operating system media and the *Driver Recovery* media (both purchased separately). For additional information, see [Using Windows operating system media \(purchased separately\) on page 138](#).

3. If the Recovery Image partition is listed, restart the computer, and then press `esc` while the “Press the ESC key for Startup Menu” message is displayed at the bottom of the screen.
4. Press `f11` while the “Press <F11> for recovery” message is displayed on the screen.
5. Follow the on-screen instructions.

Using Windows operating system media (purchased separately)

To order a Windows operating system DVD, contact support. See the *Worldwide Telephone Numbers* booklet included with the computer. You can also find contact information from the HP website. Go to <http://www.hp.com/support>, select your country or region, and follow the on-screen instructions. .

 **CAUTION:** Using a Windows operating system media completely erases hard drive contents and reformats the hard drive. All files that you have created and any software that you have installed on the computer are permanently removed. When reformatting is complete, the recovery process helps you restore the operating system, as well as drivers, software, and utilities.

To initiate a full install of the operating system using a Windows operating system DVD:

 **NOTE:** This process takes several minutes.

1. If possible, back up all personal files.
2. Insert the Windows operating system DVD into the optical drive, and then restart the computer.
3. When prompted, press any keyboard key.
4. Follow the on-screen instructions.

After the installation is completed:

1. Eject the Windows operating system media and then insert the *Driver Recovery* media.
2. Install the Hardware Enabling Drivers first, and then install Recommended Applications.

Using Windows Refresh or Windows Reset

When your computer is not working properly and you need to regain system stability, the Windows Refresh option allows you to start fresh and keep what is important to you.

The Windows Reset option allows you to perform detailed reformatting of your computer, or remove personal information before you give away or recycle your computer. For more information on these features, see Windows Help and Support.

Using HP Software Setup

HP Software Setup can be used to reinstall drivers or select software that has been corrupted or deleted from the system.

1. From the Start screen, type `HP Software Setup`.
2. Open HP Software Setup.
3. Follow the on-screen directions to reinstall drivers or select software.

Windows 7

Your computer includes HP and Windows tools to help you safeguard your information and retrieve it if you ever need to. These tools will help you return your computer to a proper working state, all with simple steps. This section provides information about the following processes:

- Creating recovery media and backups
- Restoring and recovering your system

Creating recovery media and backups

Recovery after a system failure is only as good as your most recent backup.

1. After you successfully set up the computer, create HP Recovery media. This step creates a Windows 7 operating system DVD and a *Driver Recovery* DVD. The Windows DVD can be used to reinstall the original operating system in cases where the hard drive is corrupted or has been replaced. The *Driver Recovery* DVD installs specific drivers and applications. See [Creating recovery media with HP Recovery Disc Creator \(select models only\) on page 140](#).
2. Use Windows Backup and Recovery tools to perform the following:
 - Back up individual files and folders
 - Back up your entire hard drive (select models only)
 - Create system repair discs (select models only) with the installed optical drive (select models only) or an optional external optical drive
 - Create system restore points



NOTE: This guide describes an overview of backing up, restoring, and recovering options. For more details about the tools provided, see Help and Support. To access Help and Support, select **Start > Help and Support**.



NOTE: HP recommends that you print the recovery procedures and save them for later use, in case of system instability.

In case of system failure, you can use the backup files to restore the contents of your computer. See [Backing up your information on page 141](#).

Guidelines

- When creating recovery media or backing up to discs, use any of the following types of discs (purchased separately): DVD+R, DVD+R DL, DVD-R, DVD-R DL, or DVD±RW. The discs you use will depend on the type of optical drive you are using.
- Be sure that the computer is connected to AC power before you start the recovery media creation process or the backup process.

Creating recovery media with HP Recovery Disc Creator (select models only)

HP Recovery Disc Creator is a software program that offers an alternative way to create recovery media. After you successfully set up the computer, you can create recovery media using HP Recovery Disc Creator. This recovery media allows you to reinstall your original operating system as

well as select drivers and applications if the hard drive becomes corrupted. HP Recovery Disc Creator can create two kinds of recovery DVDs:

- Windows 7 operating system DVD—Installs the operating system without additional drivers or applications.
- *Driver Recovery* DVD—Installs specific drivers and applications only, in the same way that the HP Software Setup utility installs drivers and applications.

Creating recovery media

 **NOTE:** The Windows 7 operating system DVD can be created only once. Thereafter, the option to create that media will not be available after you create a Windows DVD.

To create the Windows DVD:

1. Select **Start > All Programs > Productivity and Tools > HP Recovery Disc Creator**.
2. Select **Windows disk**.
3. From the drop-down menu, select the drive for burning the recovery media.
4. Click the **Create** button to start the burning process.

After the Windows 7 operating system DVD has been created, create the *Driver Recovery* DVD:

1. Select **Start > All Programs > Productivity and Tools > HP Recovery Disc Creator**.
2. Select **Driver disk**.
3. From the drop-down menu, select the drive for burning the recovery media.
4. Click the **Create** button to start the burning process.

Backing up your information

You should create system repair media and your initial backup immediately after initial system setup. As you add new software and data files, you should continue to back up your system on a regular basis to maintain a reasonably current backup. You should also create Windows system repair media (select models only) which can be used to start up (boot) the computer and repair the operating system in case of system instability or failure. Your initial and subsequent backups allow you to restore your data and settings if a failure occurs.

You can back up your information to an optional external hard drive, a network drive, or discs.

Note the following when backing up:

- Store personal files in the Documents library, and back it up regularly.
- Back up templates that are stored in their associated directories.
- Save customized settings that appear in a window, toolbar, or menu bar by taking a screen shot of your settings. The screen shot can be a time-saver if you have to reset your preferences.
- When backing up to discs, number each disc after removing it from the drive.

 **NOTE:** For detailed instructions on various backup and restore options, perform a search for these topics in Help and Support. To access Help and Support, select **Start > Help and Support**.

 **NOTE:** Windows includes the User Account Control feature to improve the security of your computer. You may be prompted for your permission or password for tasks such as installing software, running utilities, or changing Windows settings. Refer to Help and Support. To access Help and Support, select **Start > Help and Support**.

To create a backup using Windows Backup and Restore:

 **NOTE:** The backup process may take over an hour, depending on file size and the speed of the computer.

1. Select **Start > All Programs > Maintenance > Backup and Restore**.
2. Follow the on-screen instructions to set up your backup, create a system image (select models only), or create system repair media (select models only).

Performing a system recovery

In case of system failure or instability, the computer provides the following tools to recover your files:

- Windows recovery tools: You can use Windows Backup and Restore to recover information you have previously backed up. You can also use Windows Startup Repair to fix problems that might prevent Windows from starting correctly.
- **f11** recovery tools (select models only): You can use the **f11** recovery tools to recover your original hard drive image. The image includes the Windows operating system and software programs installed at the factory.

 **NOTE:** If you are unable to boot (start up) your computer and you cannot use the system repair media you previously created (select models only), you must purchase Windows 7 operating system media to reboot the computer and repair the operating system. For additional information, see [Using Windows 7 operating system media on page 144](#).

Using the Windows recovery tools

Using the Windows recovery tools, you can:

- Recover individual files
- Restore the computer to a previous system restore point
- Recover information using recovery tools

 **NOTE:** For detailed instructions on various recovery and restore options, perform a search for these topics in Help and Support. To access Help and Support, select **Start > Help and Support**.

 **NOTE:** Windows includes the User Account Control feature to improve the security of your computer. You may be prompted for your permission or password for tasks such as installing software, running utilities, or changing Windows settings. Refer to Help and Support. To access Help and Support, select **Start > Help and Support**.

To recover information you previously backed up:

1. Select **Start > All Programs > Maintenance > Backup and Restore**.
2. Follow the on-screen instructions to recover your system settings, your computer (select models only), or your files.

To recover your information using Startup Repair, follow these steps:

 **CAUTION:** Some Startup Repair options will completely erase and reformat the hard drive. All files you have created and any software installed on the computer are permanently removed. When reformatting is complete, the recovery process restores the operating system, as well as the drivers, software, and utilities from the backup used for recovery.

1. If possible, back up all personal files.
2. If possible, check for the presence of the Windows partition.

To check for the Windows partition, select **Start > Computer**.

 **NOTE:** If the Windows partition is not listed, you must recover your operating system and programs using the Windows 7 operating system DVD and the Driver Recovery media. For additional information, see [Using Windows 7 operating system media on page 144](#).

3. If the Windows partition is listed, restart the computer, and then press **f8** before the Windows operating system loads.
4. Select **Startup Repair**.
5. Follow the on-screen instructions.

 **NOTE:** For additional information on recovering information using the Windows tools, select **Start > Help and Support**.

Using f11 recovery tools (select models only)

 **CAUTION:** Using **f11** completely erases hard drive contents and reformats the hard drive. All files that you have created and any software that you have installed on the computer are permanently removed. The **f11** recovery tool reinstalls the operating system and HP programs and drivers that were installed at the factory. Software not installed at the factory must be reinstalled.

To recover the original hard drive image using **f11**:

1. If possible, back up all personal files.
2. If possible, check for the presence of the HP Recovery partition: click **Start**, right-click **Computer**, click **Manage**, and then click **Disk Management**.

 **NOTE:** If the HP Recovery partition is not listed, you must recover your operating system and programs using the Windows 7 operating system media and the Driver Recovery media. For additional information, see [Using Windows 7 operating system media on page 144](#).

3. If the HP Recovery partition is listed, restart the computer, and then press **esc** while the “Press the ESC key for Startup Menu” message is displayed at the bottom of the screen.
4. Press **f11** while the “Press <F11> for recovery” message is displayed on the screen.
5. Follow the on-screen instructions.

Using Windows 7 operating system media

If you cannot use the recovery media you previously created using the HP Recovery Disc Creator (select models only), you must purchase a Windows 7 operating system DVD to reboot the computer and repair the operating system.

To order a Windows 7 operating system DVD, go to the HP website. For U.S. support, go to <http://www.hp.com/support>. For worldwide support, go to http://welcome.hp.com/country/us/en/wwcontact_us.html. You can also order the DVD by calling support. For contact information, see the *Worldwide Telephone Numbers* booklet included with the computer.

 **CAUTION:** Using a Windows 7 operating system DVD completely erases hard drive contents and reformats the hard drive. All files that you have created and any software that you have installed on the computer are permanently removed. When reformatting is complete, the recovery process helps you restore the operating system, as well as drivers, software, and utilities.

To initiate recovery using a Windows 7 operating system DVD:

 **NOTE:** This process takes several minutes.

1. If possible, back up all personal files.
2. Restart the computer, and then insert the Windows 7 operating system DVD into the optical drive before the Windows operating system loads.
3. When prompted, press any keyboard key.
4. Follow the on-screen instructions.
5. Click **Next**.
6. Select **Repair your computer**.
7. Follow the on-screen instructions.

After the repair is completed:

1. Eject the Windows 7 operating system DVD and then insert the *Driver Recovery DVD*.
2. Install the Hardware Enabling Drivers first, and then install Recommended Applications.

SUSE Linux – Backup and recovery

Recovery after a system failure is as good as your most recent backup. As you add new software and data files, you should continue to back up your system on a regular basis to maintain a reasonably current backup.

Your computer includes tools provided by HP to help you safeguard your information and retrieve it if ever needed.

Creating backups

1. Create restore media immediately after you set up the computer.
2. As you add files, routinely create a backup of your system and personal information.

Backing up your information

You should back up your computer files on a regular schedule to maintain a current backup. You can manually back up your information to an optional external drive, a network drive, or discs. Back up your system at the following times:

- At regularly scheduled times
- Before the computer is repaired or restored
- Before you add or modify hardware or software

To back up your home directory files using **Backup Manager Settings**:

1. Select **Computer > More Applications > Tools > Backup Manager Settings**, and click **Backup my home directory**.
2. Click **Storage Destination Location**, and then select a location to back up your information.
3. Click **Schedule**, and then select a time schedule to perform backups at a regularly scheduled time.

To immediately back up your information, click the **Backup Now** check box.

 **NOTE:** Before you back up your information, be sure you have designated a location to save the backup files.

4. Click **Save and Backup** to start the backup and to save the backup settings.

To restore backup files:

1. Select **Computer > More Applications > Tools > Backup Manager Restore**.
2. Click **Backup Source**, and then select the location of the backup files.
3. Click **Restore Destination**, and then select the destination to restore the files.
4. To restore all files from the selected location, click **Restore all files**. To restore select files only, click **Restore selected files**, click **Select Files** and then select the files to be restored.
5. Under **Restore Point**, click the time and date of the backup.

 **NOTE:** If multiple backups have been performed, click **Use the latest version** to restore the latest version.

6. Click **Restore** to start restoring the files, or click **Cancel** to cancel the operation.

Performing a system recovery

Recovery allows you to repair or restore the computer to its original factory state. You can create an HP Factory Image Restore DVD, using an installed or an external DVD±RW optical drive.

 **CAUTION:** Using Recovery completely erases hard drive contents and reformats the hard drive. All files you have created and any software installed on the computer are permanently removed. The recovery tool reinstalls the original operating system and HP programs and drivers that were installed at the factory. Software, drivers, and updates not installed by HP must be manually reinstalled. Personal files must be restored from a backup.

To restore the computer using the HP Factory Image Restore DVD, you must first create the recovery disc. To create the recovery disc:

 **NOTE:** HP recommends that you create the HP Factory Image Restore DVD in the event of a system failure.

1. Select **Computer > More Applications**.
2. In the left pane, click **Tools**, and then click **Create HP Factory Image Restore DVD** in the right pane.
3. Follow the on-screen instructions to create an image file to burn a recovery disc.

To restore the computer from the recovery disc, follow these steps:

1. If possible, back up all personal files.
2. Insert the HP Factory Image Restore DVD into the optical drive and restart the computer.
3. As the computer is restarting, press **f9** to open the Computer Setup boot option menu.
4. Press the down arrow to select **Restore SLED HP-BNB preload image** from the **Linux boot** menu, and then press **enter**.
5. Using the arrow keys, select **Yes** when prompted: **Do you want to start the System-Restore?**
6. Follow the on-screen instructions.

Remove everything and reinstall SLED

Sometimes you want to perform detailed reformatting of your computer, or you want to remove personal information before you give away or recycle your computer. The process described in this section provides a speedy, simple way to return the computer to its original state. This option removes all personal data, applications, and settings from your computer, and reinstalls the Linux operating system.

 **IMPORTANT:** This option does not provide backups of your information. Before using this option, back up any personal information you wish to retain.

You can initiate this option by using the **f11** key.

To use the **f11** key:

Press **f11** while the computer boots.

– or –

Press and hold **f11** as you press the power button.

The following options are available:

- **Cancel/Reboot**—Reboots the system. No recovery or restore activity is performed.
- **Recover/Repair System**—This option repairs a system that is not working properly and preserves user data.
- **Restore Factory System**—This option restores the system back to the original factory state. User data is not preserved.

Select an option and follow the on-screen instructions.

10 Statement of Volatility

The purpose of this document is to provide general information regarding non-volatile memory in industry-standards based HP Business Notebook PC systems and provide general instructions for restoring nonvolatile memory that can contain personal data after the system has been powered off and the hard drive has been removed.

HP Business Notebook PC products that use Intel®-based or AMD®-based system boards contain volatile DDR memory. The amount of nonvolatile memory present in the system depends upon the system configuration. Intel-based and AMD-based system boards contain nonvolatile memory subcomponents as originally shipped from HP assuming that no subsequent modifications have been made to the system and assuming that no applications, features, or functionality have been added to or installed on the system.

Following system shutdown and removal of all power sources from an HP Business Notebook PC system, personal data can remain on volatile system memory (DIMMs) for a finite period of time and will also remain in nonvolatile memory. The steps below will remove personal data from the notebook PC, including the nonvolatile memory found in Intel-based and AMD-based system boards. Some of these steps are disclosed in the Maintenance & Service Guides available for HP PC products available on the product support pages at www.hp.com.

1. Follow steps (a) through (i) below to restore the nonvolatile memory that can contain personal data. Restoring or re-programming nonvolatile memory that does not store personal data is neither necessary nor recommended.
 - a. Enter BIOS (F10) Setup by powering on the system and pressing **F10** when prompted near the bottom of the display, or press the **ESC** key to display the start up menu, and then press **F10** . If the system has a BIOS administrator password, enter the password at the prompt.
 - b. Select the **Main** menu, and then select **Restore Defaults**.
 - c. Select the **Security** menu, and then select **Restore Security Level Defaults**.
 - d. If an asset or ownership tag is set, select the **Security** menu and scroll down to the **Utilities** menu. Select **System IDs**, and then select **Asset Tracking Number**. Press the spacebar once to clear the tag, and then press **Enter** to return to the prior menu.
 - e. If a DriveLock password is set, select the **Security** menu, select **Hard Drive Tools**, scroll down to **DriveLock**, and then clear the check box for **DriveLock password on restart**. Repeat this procedure if more than one hard drive has a DriveLock password.
 - f. If an Automatic DriveLock password is set, select the **Security** menu, select **Hard Drive Tools**, and then scroll down to **Automatic DriveLock**. A warning screen about automatic drive lock is displayed, Select Yes to continue. Repeat this procedure if more than one hard drive has an Automatic DriveLock password.
 - g. Select the **Main** menu, and then **Reset BIOS Security** to factory default. Click **yes** at the warning message.
 - h. Select the **Main** menu, and then **Save Changes and Exit**.
 - i. Reboot the system. If the system has a Trusted Platform Module (TPM) and/or fingerprint sensor, one or two prompts will appear. One to clear the TPM and the other to Reset Fingerprint Sensor; press **F1** to accept or **F2** to reject.

If the HP notebook model number ends in a 'p' or 'w' and includes Intel® Centrino with VPro™, reboot the PC and enter BIOS Setup by pressing **F10** when prompted. Select **System Configuration**, select **AMT Options**, and then select **Un-configure AMT on next boot**. Select **Save**, and then select **Yes**. Select the **File** menu, and then select **Save Changes and Exit**. Reboot the system and confirm that you want to un-configure AMT.

- j. If the optional Intel® Anti-Theft Technology (AT) was activated, contact the provider to deactivate it.
 - k. If the optional Absolute® Software Computrace® management and tracking service was activated on the notebook PC, contact the provider to deactivate it.
 - l. Remove all power and system batteries for at least 24 hours.
2. Remove and retain the storage drive or clear the contents of the drive.

a. Hard Disk Drive (HDD)

Clear the HDD contents by using the HP Disk Sanitizer® utility or a third party application that, ideally, is U.S. Department of Defense (DOD) 5220.22-M approved.

To run HP Disk Sanitizer, enter BIOS Setup by powering on the system and pressing **F10** when prompted near the bottom of the display, or press **ESC** to display the startup menu, and then press **F10**. Select the **Security** menu, scroll down to the **Utilities** menu, and then select **Hard Drive Tools**. Select **Disk Sanitizer**, and then select the desired drive. For a higher level of protection, select **Optimum**.



NOTE: This process will take a long time, and the amount of time varies based on the hard drive capacity.

b. Solid State Drive (SSD)

Clear the SSD contents by using the BIOS Setup Secure Erase command option, or by using a third party utility designed to erase data from an SSD. To run Secure Erase, enter BIOS Setup by powering on the system and pressing **F10** when prompted near the bottom of the display. Select the **Security** menu and scroll down to the **Utilities** menu. Select **Secure Erase** and select the desired hard drive.

Non-volatile memory usage

Non Volatile Memory Type	Amount (Size)	Does this memory store customer data?	Does this memory retain data when power is removed?	What is the purpose of this memory?	How is data input into this memory?	How is this memory write protected?
Real Time Clock (RTC) battery backed-up CMOS configuration memory (CMOS)	256 Bytes	No	Yes	Stores system date and time and limited keyboard controller data.	Using the F10 Setup utility or changing the Microsoft® Windows® date & time.	This memory is not write-protected. HP recommends password protecting the F10 Setup utility.

Non Volatile Memory Type	Amount (Size)	Does this memory store customer data?	Does this memory retain data when power is removed?	What is the purpose of this memory?	How is data input into this memory?	How is this memory write protected?
Controller (NIC) EEPROM	64 Kbytes (not customer accessible)	No	Yes	Store NIC configuration and NIC firmware.	Using a utility from the NIC vendor that can be run from DOS.	A utility is required to write data to this memory and is available from NIC vendor. Writing data to this ROM in an inappropriate manner will render the NIC non-functional.
Keyboard ROM	64 Kbytes (not customer accessible)	No	Yes	Stores firmware code (keyboard, mouse, & battery management).	Programmed at the factory. Code is updated when the system BIOS is updated.	A utility is required for writing data to this memory and is available on the HP website. Writing data to this ROM in an inappropriate manner can render the PC non-functional.
DIMM Serial Presence Detect (SPD) configuration data	256 Bytes per memory module, 128 Bytes programmable (not customer accessible)	No	Yes	Stores memory module information.	Programmed by the memory vendor.	Data cannot be written to this memory when the module is installed in a PC. The specific write protection method varies by memory vendor.
System BIOS	4 to 5 MBytes	Yes	Yes	Store system BIOS code and PC configuration data.	System BIOS code is programmed at the factory. Code is updated when the system BIOS is updated. Configuration data and settings are input using the F10 setup utility or a custom utility.	A utility is required for writing data to this memory and is available on the HP website. Writing data to this ROM in an inappropriate manner can render the PC non-functional.
Intel Management Engine Firmware (present only in models ending in a 'p', 'w', or 'm' or with Intel Centrino Pro technology)	1.5 or 5MByte	Yes	Yes	Stores Management Engine Code, Settings, Provisioning Data and iAMT third party data store.	Management Engine Code is programmed at the factory. Code is updated via Intel secure firmware update utility. Unique Provisioning Data can be entered at the factory or by an administrator using the Management Engine (MEBx) setup utility. The third party data store contents can be populated by a remote management console or local applications registered by an administrator to have access to the space.	The Intel chipset is configured to enforce HW protection to block all direct read/write access to this area. An Intel utility is required for updating the firmware. Only firmware updates digitally signed by Intel can be applied using this utility.

Non Volatile Memory Type	Amount (Size)	Does this memory store customer data?	Does this memory retain data when power is removed?	What is the purpose of this memory?	How is data input into this memory?	How is this memory write protected?
Bluetooth flash	2Mbit	No	Yes	Stores Bluetooth configuration and firmware.	Programmed at the factory. Tools for writing data to this memory are not publicly available but can be obtained from the silicon vendor.	A utility is required for writing data to this memory and is made available through newer versions of the driver if the flash requires an upgrade.
802.11 WLAN EEPROM	4kb to 8kb	No	Yes	Stores configuration and calibration data.	Programmed at the factory. Tools for writing data to this memory are not made public.	A utility is required for writing data to this memory and is typically not made available to the public unless a firmware upgrade is necessary to address a unique issue.
Webcamera	64K bit	No	Yes	Store Web Cam configuration and firmware.	Using a utility from the device manufacturer that can be run from Windows.	A utility is required for writing data to this memory and is typically not made available to the public unless a firmware upgrade is necessary to address a unique issue.
Fingerprint reader	512kByte Flash	Yes	Yes	Stores fingerprint templates.	By enrolling in HP ProtectTools Security Manager.	Only a digitally signed application can make the call to write to the flash.

Questions and answers

1. **How can the BIOS settings be restored (returned to factory settings)?**
 - a. Turn on or restart the computer and press **F10** when prompted near the bottom of the display.
 - b. Select **Main**, and then select **Restore defaults**.
 - c. Follow the on-screen instructions.
 - d. Select **Main**, **Save Changes and Exit**, and then press **Enter**.
2. **What kind of configuration data is stored on the DIMM Serial Presence Detect (SPD) memory module? How would this data be written?**

The DIMM SPD memory contains information about the memory module such as size, serial number, data width, speed/timing, voltage and thermal information. This information is written by the module manufacturer and stored on an EEPROM. This EEPROM cannot be written to when the memory module is installed in a PC. Third party tools do exist that can write to the EEPROM when the memory module is not installed in a PC. There are various third party tools available to read SPD memory.

- 3. Does the “Firmware Hub for System BIOS” contain the BIOS program? Is this chip writable, and if so how?**

The Firmware Hub does contain the BIOS program and is writable. A utility is required to perform the write function.

- 4. In some PC systems, the Firmware Hub for System BIOS is a flash memory chip so that updates can be written by the customer. Is this true for these BIOS chips?**

Yes, they are flash memory chips.

- 5. What is meant by “Restore the nonvolatile memory found in Intel-based system boards”?**

This relates to clearing the Real Time Clock (RTC) CMOS memory that contains PC configuration data.

- 6. Does resetting the CMOS configuration memory return the PC back to factory defaults?**

The process of resetting the CMOS will return certain system settings to factory default but will not reset many of the system data and configuration defaults to their factory settings. To return these system data and configuration defaults to factory settings, refer to question and answer 1 and follow the instructions for returning the BIOS settings to factory defaults.

11 Power cord set requirements

The wide-range input feature of the computer permits it to operate from any line voltage from 100 to 120 volts AC, or from 220 to 240 volts AC.

The 3-conductor power cord set included with the computer meets the requirements for use in the country or region where the equipment is purchased.

Power cord sets for use in other countries and regions must meet the requirements of the country or region where the computer is used.

Requirements for all countries

The following requirements are applicable to all countries and regions:

- The length of the power cord set must be at least 1.0 m (3.3 ft) and no more than 2.0 m (6.5 ft).
 - All power cord sets must be approved by an acceptable accredited agency responsible for evaluation in the country or region where the power cord set will be used.
 - The power cord sets must have a minimum current capacity of 10 amps and a nominal voltage rating of 125 or 250 V AC, as required by the power system of each country or region.
 - The appliance coupler must meet the mechanical configuration of an EN 60 320/IEC 320 Standard Sheet C13 connector for mating with the appliance inlet on the back of the computer.
- Requirements for all countries 113

Requirements for specific countries and regions

Country/region	Accredited agency	Applicable note number
Australia	EANSW	1
Austria	OVE	1
Belgium	CEBC	1
Canada	CSA	2
Denmark	DEMKO	1
Finland	FIMKO	1
France	UTE	1
Germany	VDE	1
Italy	IMQ	1
Japan	METI	3
The Netherlands	KEMA	1
Norway	NEMKO	1
The People's Republic of China	COC	5

Country/region	Accredited agency	Applicable note number
South Korea	EK	4
Sweden	CEMKO	1
Switzerland	SEV	1
Taiwan	BSMI	4
The United Kingdom	BSI	1
The United States	UL	2

1. The flexible cord must be Type HO5VV-F, 3-conductor, 1.0-mm² conductor size. Power cord set fittings (appliance coupler and wall plug) must bear the certification mark of the agency responsible for evaluation in the country or region where it will be used.
2. The flexible cord must be Type SPT-3 or equivalent, No. 18 AWG, 3-conductor. The wall plug must be a two-pole grounding type with a NEMA 5-15P (15 A, 125 V) or NEMA 6-15P (15 A, 250 V) configuration.
3. The appliance coupler, flexible cord, and wall plug must bear a “T” mark and registration number in accordance with the Japanese Dentori Law. The flexible cord must be Type VCT or VCTF, 3-conductor, 1.00-mm² conductor size. The wall plug must be a two-pole grounding type with a Japanese Industrial Standard C8303 (7 A, 125 V) configuration.
4. The flexible cord must be Type RVV, 3-conductor, 0.75-mm² conductor size. Power cord set fittings (appliance coupler and wall plug) must bear the certification mark of the agency responsible for evaluation in the country or region where it will be used.
5. The flexible cord must be Type VCTF, 3-conductor, 0.75-mm² conductor size. Power cord set fittings (appliance coupler and wall plug) must bear the certification mark of the agency responsible for evaluation in the country or region where it will be used.

12 Recycling

When a non-rechargeable or rechargeable battery has reached the end of its useful life, do not dispose of the battery in general household waste. Follow the local laws and regulations in your area for battery disposal.

HP encourages customers to recycle used electronic hardware, HP original print cartridges, and rechargeable batteries. For more information about recycling programs, see the HP Web site at <http://www.hp.com/recycle>.

Index

A

- AC adapter, spare part number 45
- AC adapter, spare part numbers 42
- AC adapter/battery light 18
- audio, product description 5
- audio-in (microphone) jack, identifying 21
- audio-out (headphone) jack, identifying 21
- audio/USB board
 - spare part number 33

B

- Backup and Restore 142
- backups
 - creating 141
- Base enclosure
 - spare part number 46, 49
- base enclosure
 - removal 89
 - spare part number 89
- base enclosure, spare part number 36
- battery
 - removal 63
 - spare part numbers 37, 45, 63
- battery bay, identifying 24
- battery release latch 23
- Blu-ray R/RE DVD±RW SuperMulti Double-Layer Combo Drive
 - removal 76
 - spare part number 42, 56
- Blu-ray R/RE DVD±RW SuperMulti Double-Layer Drive
 - precautions 58
 - spare part number 36
- Blu-ray ROM DVD±RW Combo Drive
 - spare part number 54, 76
- Blu-ray ROM DVD±RW SuperMulti Double-Layer Drive
 - precautions 58
- bottom components 23

buttons

- left pointing stick 17
- left TouchPad 17
- optical drive eject 19, 20
- power 12
- right pointing stick 17
- right TouchPad 17
- Windows button 13, 14

C

- Cable Kit
 - spare part number 53
- cables
 - components 39
- cables, service considerations 58
- caps lock light, identifying 15, 16
- chipset, product description 1
- components
 - bottom 23
 - display 10
 - front 17
 - left-side 18
 - rear 22
 - right-side 21
- computer
 - major components 27
 - specifications 133
- computer reset 147
- connector, power 18, 19
- connectors, service considerations 58

D

- display assembly
 - removal 115
 - spare part numbers 115
- Display bezel
 - spare part number 46, 49
- display bezel
 - removal 115
 - spare part numbers 38, 52, 55, 115
- Display Cable Kit
 - spare part number 39

Display cable kit

- spare part number 46, 49
- display cable kit
 - illustrated 39
- display hinge kit
 - spare part number 46
- display panel
 - product description 3
 - removal 116
 - spare part number 52
 - spare part numbers 38, 55, 56
- Display Panel Support Kit
 - spare part number 46, 49
- dock/expansion base
 - spare part numbers 44
- docking connector, identifying 23
- Driver Recovery DVD,
 - creating 140
- drives, preventing damage 58
- Dual-Mode DisplayPort,
 - identifying 21
- DVD-ROM Drive
 - precautions 58
 - removal 76
 - spare part number 36, 42, 52, 54, 56, 76
- DVD-ROM SuperMulti Drive
 - spare part number 52, 54, 56
- DVD±RW Double-Layer Combo Drive
 - spare part number 52
- DVD±RW SuperMulti Double-Layer Drive
 - precautions 58
 - removal 76
 - spare part number 36, 42, 76

E

- electrostatic discharge 58
- embedded numeric keypad,
 - identifying 13
- equipment guidelines 61
- esc key, identifying 13, 14
- Ethernet, product description 6
- ExpressCard slot 19, 20

- external monitor port 21
- F**
- f11 recovery 137
- Fan
 - spare part number 46
- fan
 - removal 85
 - spare part numbers 85
- fan and heat sink assembly
 - spare part numbers 36
- Fingerprint bracket, illustrated 40
- Fingerprint reader
 - spare part number 46
- fingerprint reader bezel,
 - illustrated 40
- fingerprint reader board
 - removal 96
 - spare part number 32, 96
- fingerprint reader board bracket
 - removal 97
- fingerprint reader, identifying 12
- flash cache, product description 4
- fn key, identifying 13, 14
- front components 17
- Function button board
 - spare part number 45
- function button board
 - removal 106
 - spare part number 32, 106
- function keys, identifying 13, 14
- fusion controller hub, product description 1
- G**
- graphics, product description 2
- grounding guidelines 58
- guidelines
 - equipment 61
 - grounding 58
 - packaging 60
 - transporting 60
 - workstation 60
- H**
- hard drive
 - precautions 58
 - product description 5
 - removal 65
 - spare part numbers 37, 41, 43, 44, 45, 65
 - specifications 133
- hard drive bracket
 - illustrated 41
- Hard Drive Hardware Kit
 - contents 41
 - spare part number 37, 41
- Hard drive hardware kit
 - spare part number 46
- hard drive light 18
- hard drive recovery 137
- hard drive, identifying 23
- headphone (audio-out) jack 21
- heat sink
 - removal 85
 - spare part numbers 46, 85
- Heat sink assembly
 - spare part number 46
- hinge
 - spare part number 39, 51
- hinge bracket
 - removal 117
- hinge cover
 - spare part number 117
- Hinge Kit, spare part number 51
- HP Recovery Disc Creator,
 - using 140
- I**
- integrated numeric keypad,
 - identifying 14
- integrated webcam light,
 - identifying 10
- internal display switch 11
- internal microphones, identifying 10
- J**
- jacks
 - audio-in (microphone) 21
 - audio-out (headphone) 21
 - network 18, 19
 - RJ-11 (modem) 22
 - RJ-45 (network) 18, 19
- K**
- keyboard
 - product description 7
- removal 79
- spare part numbers 28, 46, 47, 48, 49, 50, 51, 79
- keypad
 - embedded numeric 13
 - integrated numeric 14
- keys
 - esc 13, 14
 - fn 13, 14
 - function 13, 14
 - Windows applications 13
- L**
- latch, battery release 23
- latches, service cover release 24
- left-side components 18
- lights
 - AC adapter/battery 18
 - caps lock 15, 16
 - hard drive 18
 - microphone mute 15, 16
 - num lock 15, 16
 - power 15, 16, 18
 - TouchPad 15, 16
 - webcam 10
 - wireless 15, 16, 18
- M**
- mass storage device
 - illustrated 41
 - precautions 58
 - spare part numbers 41
- Memory card reader, identifying 19
- memory module
 - identifying 23
 - inserting 69
 - product description 4
 - removal 68, 71
 - removing 69
 - spare part numbers 44, 68, 71
- microphone
 - product description 5
- microphone (audio-in) jack,
 - identifying 21
- microphone module
 - removal 118
 - spare part number 38, 46, 119
- microphone mute light 15, 16

- model name 1
- Modem
 - spare part number 43
- Modem module
 - spare part numbers 36
- modem module
 - removal 67
 - spare part number 67
 - spare part numbers 67
- modemtransfer board
 - spare part number 52
- mouse, spare part numbers 44

- N**
- network cable
 - illustrated 39
- network jack, identifying 18, 19
- num lock light 15, 16

- O**
- operating system, product
 - description 8
- optical drive
 - precautions 58
 - removal 76
 - spare part numbers 36, 42, 52, 54, 56, 76
- optical drive blank tray
 - illustrated 40
- optical drive eject button,
 - identifying 19, 20
- optical drive transfer board
 - spare part number 52

- P**
- packaging guidelines 60
- plastic parts, service
 - considerations 57
- Plastics Kit
 - components 40
 - spare part number 40, 52
- Plastics kit
 - spare part number 45
- pointing device, product
 - description 7
- pointing stick 17
- ports
 - Dual-Mode DisplayPort 21
 - external monitor 21
 - product description 6
 - serial 22
- power button board
 - removal 94
 - spare part number 32, 46, 51, 94
- power button, identifying 12
- Power cable
 - spare part number 46, 49
- power connector board
 - spare part number 32
- power connector cable
 - removal 112
- power connector, identifying 18, 19
- power cord
 - set requirements 154
 - spare part numbers 42, 43
- power lights 15, 16, 18
- power requirements, product
 - description 7
- processor
 - product description 1
 - removal 108
 - spare part numbers 32, 44, 45, 46, 108
- product description
 - audio 5
 - chipset 1
 - display panel 3
 - Ethernet 6
 - external media cards 6
 - flash cache 4
 - fusion controller hub 1
 - graphics 2
 - hard drive 5
 - keyboard 7
 - memory module 4
 - microphone 5
 - operating system 8
 - pointing device 7
 - ports 6
 - power requirements 7
 - processor 1
 - product name 1
 - security 7
 - serviceability 9
 - solid-state drive 4
 - Upgrade drive 5
 - video 5
 - wireless 6
- product name 1

- R**
- recovery 139
- recovery media, creating 140
- recovery partition 137
- refresh 139
- removal/replacement
 - procedures 62
- reset
 - computer 147
 - steps 147
- restoring the hard drive 137
- right-side components 21
- RJ-11 (modem) jack, identifying
 - 22
- RJ-45 (network) jack, identifying
 - 18, 19
- RJ-45 cable
 - illustrated 39
- RTC battery
 - removal 113
 - spare part number 44, 113
- Rubber kit
 - spare part number 46

- S**
- Screw Kit, spare part number 43, 49
- SD card reader bezel, illustrated
 - 40
- security cable slot, identifying 21
- security, product description 7
- serial port, identifying 22
- service considerations
 - cables 58
 - connectors 58
 - plastic parts 57
- Service cover
 - spare part number 46, 49
- service cover
 - removal 64
 - spare part number 37, 55, 64
- service cover release latch 24
- service cover release lock,
 - identifying 23
- service tag 25
- serviceability, product
 - description 9
- SIM slot, identifying 23

- SLED
 - remove everything and reinstall option 147
- slots
 - ExpressCard 19, 20
 - security cable 21
 - SIM 23
 - smart card 19, 20
- Smart card reader
 - spare part numbers 52
- smart card reader
 - removal 98
 - spare part number 32, 46, 55, 98
- Smart card reader blank, illustrated 40
- smart card slot 19, 20
- solid-state drive
 - precautions 58
 - product description 4
 - removal 78
 - spare part numbers 37, 41, 55, 56, 78
- Speaker kit
 - spare part number 45
- Speaker Kit, spare part number 32
- speakers
 - removal 104
 - spare part number 32, 104
- speakers, identifying 12
- specifications
 - computer 133
 - hard drive 133
- system board
 - removal 99
 - spare part numbers 33, 52, 53, 54, 55, 99
- T**
- tools required 57
- Top cover
 - spare part number 45
- top cover
 - spare part number 32, 52
 - spare part numbers 55
- top hinge cover, spare part number 28
- TouchPad
 - buttons 17
 - removal 110
 - spare part number 32, 46, 52, 110
- TouchPad light, identifying 15, 16
- TouchPad zone
 - identifying 17
- transporting guidelines 60
- U**
- upgrade bay 19
- Upgrade drive, product description 5
- USB 3.0 charging port 19
- USB 3.0 port 19, 21
- USB board
 - removal 92
 - spare part number 45, 51, 52, 92
 - spare part numbers 55
- USB ports, identifying 19, 21
- V**
- vents, identifying 21, 24
- video, product description 5
- W**
- webcam 10
- webcam light, identifying 10
- webcam, identifying 10
- Webcamera
 - spare part number 46
- webcamera/microphone module
 - removal 118
 - spare part number 38, 119
- Windows
 - Refresh 139
- Windows 7 operating system DVD
 - creating 140
- Windows 7 operating system media
 - creating 140
- Windows 8 operating system DVD 138
- Windows applications key, identifying 13
- Windows button, identifying 13, 14
- wireless antennas, identifying 10
- wireless light 15, 16, 18
- wireless, product description 6
- WLAN antennas, identifying 10
- WLAN bracket, illustrated 40
- WLAN module
 - removal 74
 - spare part numbers 36, 44, 45, 55, 74
- workstation guidelines 60
- WWAN antennas, identifying 10
- WWAN module
 - removal 73
 - spare part numbers 37, 45, 73