

INSTRUCTION SHEET
RSH SERIES
CUSTOM LCD MOUNT

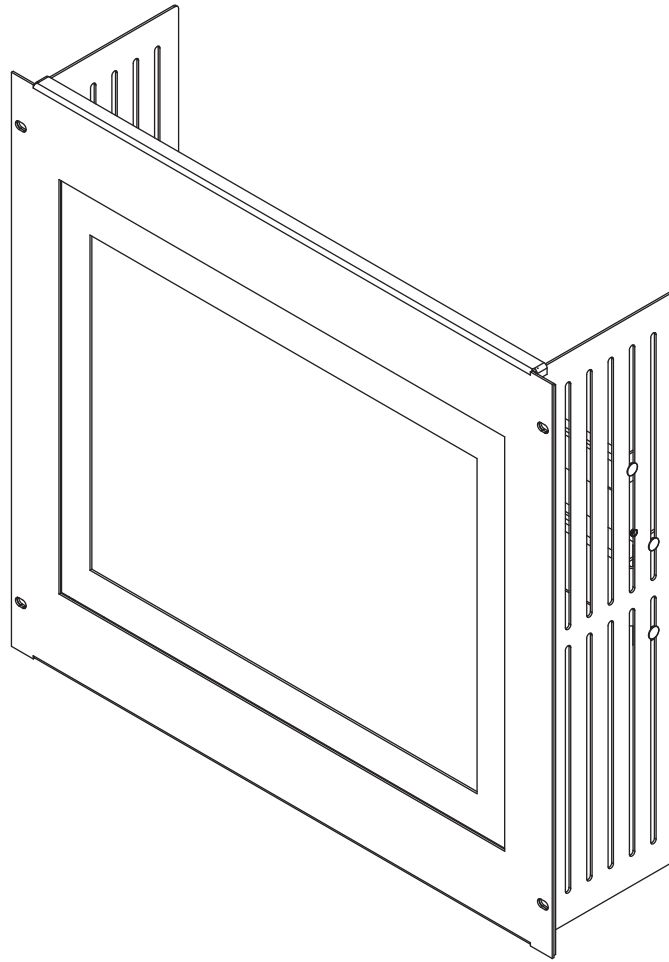

THANK YOU

Thank you for purchasing the RSH Custom LCD Mount. Please read these instructions thoroughly before installing / assembling this product.

PRODUCT FEATURES

- Accommodates most LCD screens
- Securely mounts an LCD monitor within the enclosure
- Clamping design captivates the monitor even when mounted into a sloped surface



Middle Atlantic Products

I-00064

Rev D

ASSEMBLY

1) Place the monitor face-down.

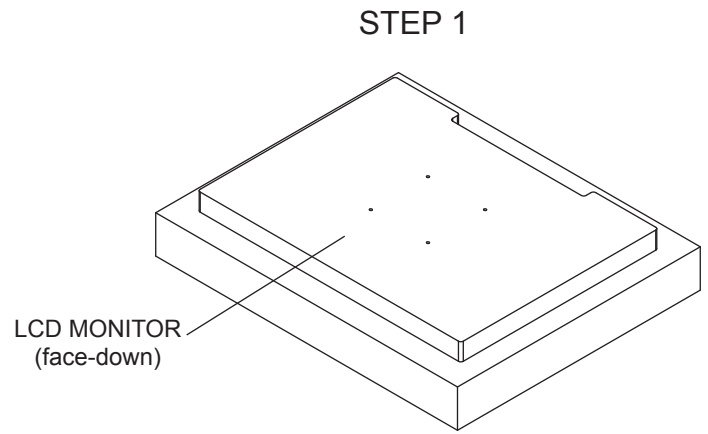

2) Determine which VESA bracket to use by placing bracket against back of monitor and matching hole spacing.

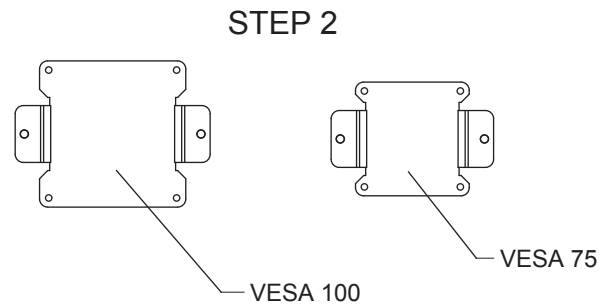

3) Assemble the VESA bracket as shown using the supplied hardware.

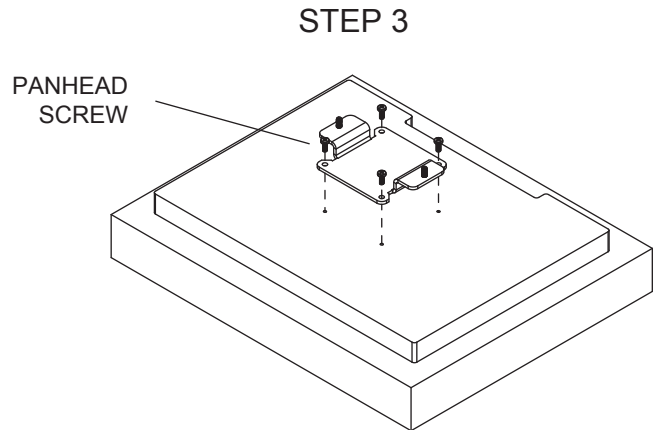

4) Assemble the Monitor Support Bracket as shown using the supplied hardware.

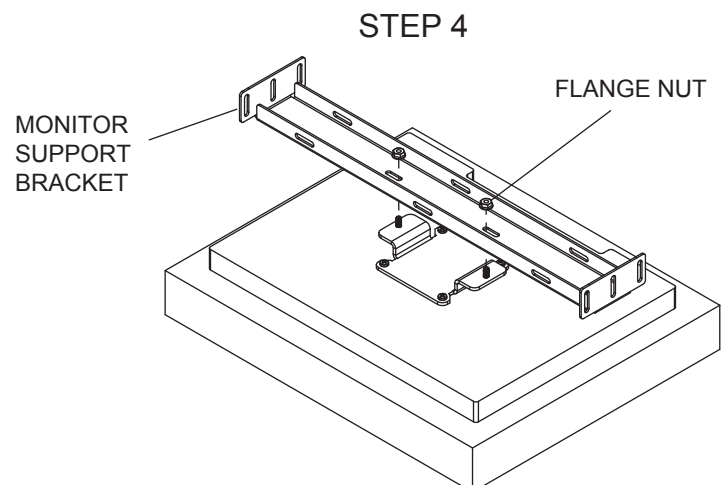

- 5) Place the faceplate face-down and slide the ears under the faceplate tabs as shown.

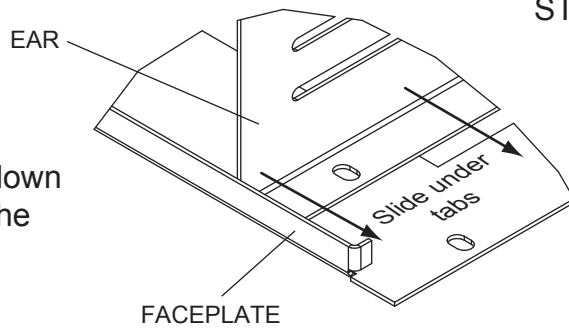

STEP 5

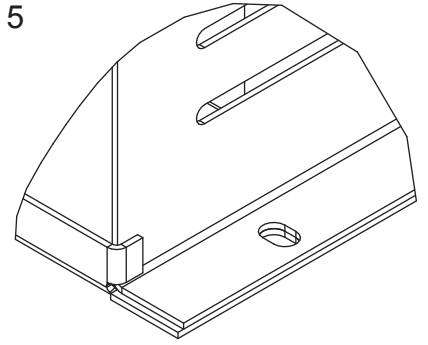

- 6) Place the monitor inside the mount. Make sure the LCD screen is positioned correctly and fits within the cutout in the faceplate. Secure as shown using the supplied hardware.

STEP 6

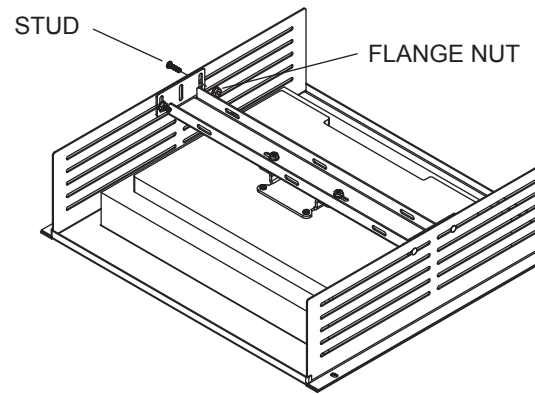

- 7) Install the monitor clamp in desired location for extra support if necessary. Secure with the supplied studs and nuts.

STEP 7

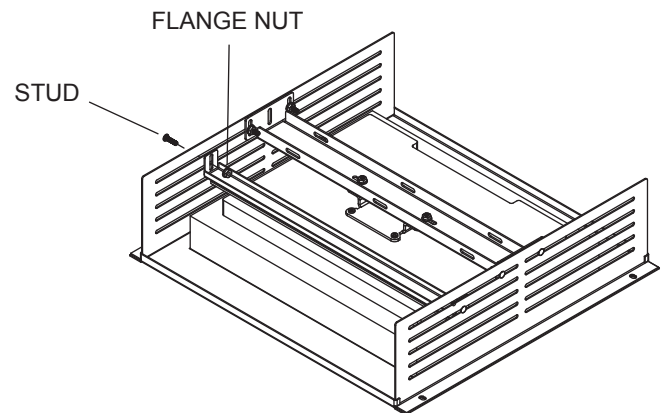

ASSEMBLED

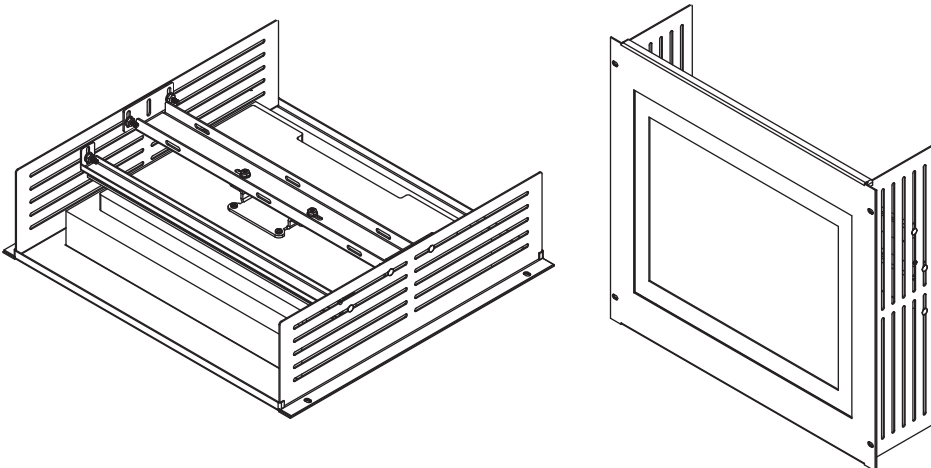

WARRANTY

Middle Atlantic Products (the "Company") warrants the RSH Custom LCD Mount Series to be free from defects in material or workmanship under normal use and conditions for the lifetime of the product.

The Company's entire liability to the purchaser, and the purchaser's (or any other party's) sole and exclusive remedy, under this warranty shall be limited, at the Company's option, to either (a) return of and refund of the price paid for, or (b) repair or replacement at the Company's factory of the products purchased, or any part or parts thereof, which the Company has determined to be defective after inspection thereof at the Company's factory.

This warranty does not cover damage due to acts of God, accident, misuse, abuse or negligence by parties other than the Company, or any modification or alteration of the products. In addition, this warranty does not cover damage due to improper handling, assembly, installation or maintenance.

THIS WARRANTY IS IN LIEU OF ALL OTHER WARRANTIES OF ANY KIND, EITHER EXPRESSED OR IMPLIED, INCLUDING, BUT NOT LIMITED TO, IMPLIED WARRANTIES OF MERCHANTABILITY AND FITNESS FOR A PARTICULAR PURPOSE.

TO THE MAXIMUM EXTENT PERMITTED BY APPLICABLE LAW, IN NO EVENT SHALL THE COMPANY BE LIABLE FOR ANY SPECIAL, INCIDENTAL, INDIRECT, OR CONSEQUENTIAL DAMAGES WHATSOEVER (INCLUDING, WITHOUT LIMITATION, DAMAGES FOR LOSS OF BUSINESS PROFITS, BUSINESS INTERRUPTION OR ANY OTHER PECUNIARY LOSS) ARISING OUT OF THE USE OF THE PRODUCTS PURCHASED, EVEN IF THE COMPANY HAS BEEN ADVISED OF THE POSSIBILITY OF SUCH DAMAGES. THE COMPANY'S LIABILITY TO THE PURCHASER (OR ANY OTHER PARTY) HEREUNDER, IF ANY, SHALL IN NO EVENT EXCEED THE PURCHASE PRICE OF THE PRODUCTS PAID TO THE COMPANY.

Corporate Headquarters

Corporate Voice 973-839-1011 - Fax 973-839-1976
International Voice +1 973-839-8821 - Fax +1 973-839-4982
middleatlantic.com - info@middleatlantic.com

Middle Atlantic Canada

Voice 613-836-2501 - Fax 613-836-2690
middleatlantic.ca - customerservicecanada@middleatlantic.ca

Factory Distribution

USA: NJ - CA - IL Canada: ON - BC

At Middle Atlantic Products we are always listening. Your comments are welcome.

Middle Atlantic Products is an ISO 9001 and ISO 14001 Registered Company.

