



JULY 2008
PSH8-S20-120V
PSH8-S20-208+V
PSH8-D20-120V
PSH8-D20-208+V
PSH16-D20-120V
PSH16-D20-208+V
PSV20-S20-120V
PSV20-S20-208+V
PSV20-S30-120V
PSV20-S30-208+V

Elite Managed Power Controller Horizontal Series & Vertical Series

**CUSTOMER
SUPPORT
INFORMATION**

Order **toll-free** in the U.S.: Call **877-877-BBOX** (outside U.S. call **724-746-5500**)
FREE technical support 24 hours a day, 7 days a week: Call **724-746-5500** or fax **724-746-0746**
Mailing address: **Black Box Corporation**, 1000 Park Drive, Lawrence, PA 15055-1018
Web site: www.blackbox.com • E-mail: info@blackbox.com

**FEDERAL COMMUNICATIONS COMMISSION
AND
INDUSTRY CANADA
RADIO FREQUENCY INTERFERENCE STATEMENTS**

This equipment generates, uses, and can radiate radio-frequency energy, and if not installed and used properly, that is, in strict accordance with the manufacturer's instructions, may cause interference to radio communication. It has been tested and found to comply with the limits for a Class A computing device in accordance with the specifications in Subpart B of Part 15 of FCC rules, which are designed to provide reasonable protection against such interference when the equipment is operated in a commercial environment. Operation of this equipment in a residential area is likely to cause interference, in which case the user at his own expense will be required to take whatever measures may be necessary to correct the interference.

Changes or modifications not expressly approved by the party responsible for compliance could void the user's authority to operate the equipment.

This digital apparatus does not exceed the Class A limits for radio noise emission from digital apparatus set out in the Radio Interference Regulation of Industry Canada.

Le présent appareil numérique n'émet pas de bruits radioélectriques dépassant les limites applicables aux appareils numériques de la classe A prescrites dans le Règlement sur le brouillage radioélectrique publié par Industrie Canada.

This product meets the applicable Industry Canada technical specifications.

The Ringer Equivalence Number is an indication of the maximum number of devices allowed to be connected to a telephone interface. The termination on an interface may consist of any combination of devices subject only to the requirement that the sum of the RENs of all the devices does not exceed five.

EUROPEAN UNION DECLARATION OF CONFORMITY

This equipment complies with the requirements of the European EMC Directive 89/336/EEC.



**NORMAS OFICIALES MEXICANAS (NOM)
ELECTRICAL SAFETY STATEMENT**

INSTRUCCIONES DE SEGURIDAD

1. Todas las instrucciones de seguridad y operación deberán ser leídas antes de que el aparato eléctrico sea operado.
2. Las instrucciones de seguridad y operación deberán ser guardadas para referencia futura.
3. Todas las advertencias en el aparato eléctrico y en sus instrucciones de operación deben ser respetadas.
4. Todas las instrucciones de operación y uso deben ser seguidas.
5. El aparato eléctrico no deberá ser usado cerca del agua—por ejemplo, cerca de la tina de baño, lavabo, sótano mojado o cerca de una alberca, etc..
6. El aparato eléctrico debe ser usado únicamente con carritos o pedestales que sean recomendados por el fabricante.
7. El aparato eléctrico debe ser montado a la pared o al techo sólo como sea recomendado por el fabricante.
8. Servicio—El usuario no debe intentar dar servicio al equipo eléctrico más allá a lo descrito en las instrucciones de operación. Todo otro servicio deberá ser referido a personal de servicio calificado.
9. El aparato eléctrico debe ser situado de tal manera que su posición no interfiera su uso. La colocación del aparato eléctrico sobre una cama, sofá, alfombra o superficie similar puede bloquea la ventilación, no se debe colocar en libreros o gabinetes que impidan el flujo de aire por los orificios de ventilación.
10. El equipo eléctrico deber ser situado fuera del alcance de fuentes de calor como radiadores, registros de calor, estufas u otros aparatos (incluyendo amplificadores) que producen calor.
11. El aparato eléctrico deberá ser connectado a una fuente de poder sólo del tipo descrito en el instructivo de operación, o como se indique en el aparato.

12. Precaución debe ser tomada de tal manera que la tierra física y la polarización del equipo no sea eliminada.
13. Los cables de la fuente de poder deben ser guiados de tal manera que no sean pisados ni pellizcados por objetos colocados sobre o contra ellos, poniendo particular atención a los contactos y receptáculos donde salen del aparato.
14. El equipo eléctrico debe ser limpiado únicamente de acuerdo a las recomendaciones del fabricante.
15. En caso de existir, una antena externa deberá ser localizada lejos de las líneas de energía.
16. El cable de corriente deberá ser desconectado del cuando el equipo no sea usado por un largo periodo de tiempo.
17. Cuidado debe ser tomado de tal manera que objetos líquidos no sean derramados sobre la cubierta u orificios de ventilación.
18. Servicio por personal calificado deberá ser provisto cuando:
 - A: El cable de poder o el contacto ha sido dañado; u
 - B: Objetos han caído o líquido ha sido derramado dentro del aparato; o
 - C: El aparato ha sido expuesto a la lluvia; o
 - D: El aparato parece no operar normalmente o muestra un cambio en su desempeño; o
 - E: El aparato ha sido tirado o su cubierta ha sido dañada.

TRADEMARKS USED IN THIS MANUAL

BLACK BOX and the Double Diamond logo are registered trademarks of BB Technologies, Inc.

ProComm is a registered trademark of DATASTORM TECHNOLOGIES, INC.™

Crosstalk is a registered trademark of Digital Communications Associates, Inc.

VT100 is a trademark of Digital Equipment Corporation.

AT is a registered trademark of International Business Machines Corporation.

Netscape Navigator is a registered trademark of Netscape Communications Corporation.

JavaScript is a registered trademark of Sun Microsystems, Inc.

Telnet is a trademark of Telnet Communications, Inc.

UNIX is a registered trademark of UNIX System Laboratories, Inc.

Any other trademarks mentioned in this manual are acknowledged to be the property of the trademark owners.

WARNINGS AND CAUTIONS

Secure Racking

If secure racked units are installed in a closed or multi-unit rack assembly, they may require further evaluation by certification agencies. Consider the following items:

1. The ambient temperature within the rack may be greater than the room ambient temperature. Installation should be such that the amount of airflow required for safe operation is not compromised. The maximum temperature for the equipment in this environment is 122°F (50°C).
2. Install the unit so that it doesn't become unstable from uneven loading.

Input Supply

Check nameplate ratings to ensure that there is no overloading of supply circuits that could have an effect on overcurrent protection and supply wiring.

Grounding

Maintain reliable grounding of this equipment. Give particular attention to supply connections when connecting to power strips, rather than direct connections to the branch circuit.

Shock Hazard

Do not attempt to repair or service this device yourself. Internal components must be serviced by authorized personnel only.

Disconnect Power

If any of the following events occurs, immediately disconnect the unit from the outlet and contact Black Box at 724-746-5500.

1. The power cord is frayed or damaged.
2. Liquid has been spilled into the device or the device has been exposed to rain or water.

Disconnect Power Supply Cable

Before attempting to service or remove this unit, make certain to disconnect the power supply cable.

Contents

1.	Specifications	13
2.	Quick Start Guide	15
2.1.	Quick Hardware Installation	15
2.1.1.	Apply Power to the Elite Managed Power Controller	15
2.1.2.	Connect your PC to the Elite Managed Power Controller ...	15
2.2.	Communicating with the Elite Managed Power Controller	16
3.	Overview	19
3.1.	Horizontal Series - Front Panel Components	21
3.2.	Horizontal Series - Back Panel	22
3.3.	Vertical Series - Hardware Description	25
3.4.	Additional Button Functions	26
4.	Hardware Installation	29
4.1.	Connecting the Power Supply Cables	29
4.1.1.	Installing the Power Supply Cable Keepers	29
4.1.2.	Connection to the Power Supply	31
4.2.	Connection to Switched Outlets	31
4.3.	Serial Console Port Connection	32
4.3.1.	Connecting a Local PC	32
4.3.2.	Connecting an External Modem	32
4.4.	Connecting the Network Cable	32
4.5.	Connecting Additional Units to the AUX Ports	33
4.6.	Rack Mounting	34
5.	Configuration	35
5.1.	Communicating with the Elite Managed Power Controller Unit	35
5.1.1.	The Text Interface	35
5.1.2.	The Web Browser Interface	37
5.1.3.	Access Via PDA	39
5.2.	Configuration Menus	40
5.3.	Defining System Parameters	41
5.3.1.	The Real Time Clock and Calendar	46
5.3.2.	The Invalid Access Lockout Feature	48
5.3.3.	Automated Mode	50

5.	Configuration (continued)	
5.3.4.	Log Configuration	52
5.3.4.1.	The Audit Log and Alarm Log	53
5.3.4.2.	The Current Metering Log and Power Metering Log	53
5.3.4.3.	Reading and Erasing Logs	54
5.3.5.	Callback Security	55
5.4.	User Accounts	57
5.4.1.	Command Access Levels	58
5.4.2.	Plug Access	59
5.4.3.	Port Access	60
5.5.	Managing User Accounts.	61
5.5.1.	Viewing User Accounts	62
5.5.2.	Adding User Accounts	62
5.5.2.1.	Granting User Account Access to Plugs on AUX Units	67
5.5.3.	Modifying User Accounts	69
5.5.4.	Deleting User Accounts.	70
5.6.	The Plug Group Directory	71
5.6.1.	Viewing Plug Groups	72
5.6.2.	Adding Plug Groups	74
5.6.2.1.	Granting User Account Access to Plugs on AUX Units	75
5.6.3.	Modifying Plug Groups.	76
5.6.4.	Deleting Plug Groups	77
5.7.	Defining Plug Parameters	78
5.7.1.	The Boot Priority Parameter	81
5.7.1.1.	Example 1: Change Plug A3 to Priority 1	82
5.7.1.2.	Example 2: Change Plug A5 to Priority 2	83
5.8.	Serial Port Configuration	84
5.8.1.	Console Port Configuration.	84
5.8.2.	Remote Port and AUX Port Configuration	89
5.9.	Network Configuration	92
5.9.1.	Network Port Parameters	94
5.9.2.	Network Parameters	96
5.9.3.	IP Security	97
5.9.3.1.	Adding IP Addresses to the Allow and Deny Lists	99
5.9.3.2.	Linux Operators and Wild Cards	100
5.9.3.3.	IP Security Examples	101
5.9.4.	Static Route	102
5.9.5.	Domain Name Server	102
5.9.6.	SNMP Access Parameters	103

- 5. Configuration (continued)
 - 5.9.7. SNMP Trap Parameters 105
 - 5.9.8. LDAP Parameters 106
 - 5.9.8.1. Adding LDAP Groups 108
 - 5.9.8.2. Viewing LDAP Groups 110
 - 5.9.8.3. Modifying LDAP Groups. 111
 - 5.9.8.4. Deleting LDAP Groups 112
 - 5.9.8.5. LDAP Kerberos Set Up 113
 - 5.9.9. TACACS Parameters. 114
 - 5.9.10. RADIUS Parameters 115
 - 5.9.10.1. Dictionary Support for RADIUS 117
 - 5.9.11. Email Message Parameters 119
- 5.10. Save User Selected Parameters 120
 - 5.10.1. Restore Configuration 121
- 6. Reboot Options 123
 - 6.1. Ping-No-Answer Reboot 124
 - 6.1.1. Adding Ping-No-Answer Reboots 124
 - 6.1.1.1. Granting Access to Plugs on AUX Units 127
 - 6.1.2. Viewing Ping-No-Answer Reboot Profiles 128
 - 6.1.3. Modifying Ping-No-Answer Reboot Profiles 129
 - 6.1.4. Deleting Ping-No-Answer Reboot Profiles 130
 - 6.2. Scheduled Reboot 131
 - 6.2.1. Adding Scheduled Reboots 131
 - 6.2.1.1. Granting Access to Plugs on AUX Units 133
 - 6.2.2. Viewing Scheduled Reboot Actions 134
 - 6.2.3. Modifying Scheduled Reboots 135
 - 6.2.4. Deleting Scheduled Reboots 136
- 7. Alarm Configuration 137
 - 7.1. The Over Current Alarms 138
 - 7.1.1. Over Current Alarms - Load Shedding and Auto Recovery. 142
 - 7.1.1.1. Granting Access to Plugs on AUX Units 145
 - 7.2. The Over Temperature Alarms 146
 - 7.2.1. Over Temperature Alarms - Load Shedding and Auto Recovery. 150
 - 7.2.1.1. Granting Access to Plugs on AUX Units 153
 - 7.3. The Circuit Breaker Open Alarm. 154
 - 7.4. The Lost Communication with AUX Units Alarm 156
 - 7.5. The Lost Voltage (Line In) Alarm 158
 - 7.6. The Ping-No-Answer Alarm 160
 - 7.7. The Invalid Access Lockout Alarm 162

8.	The Status Screens	165
8.1.	The Network Status Screen	165
8.2.	The Plug Status Screen	166
8.3.	The Plug Group Status Screen	167
8.4.	The Current Metering Log Screen	169
8.5.	The Current History Screen	170
8.6.	The Power Metering Status Screen	172
8.7.	The Power History Screen	173
9.	Operation	175
9.1.	Operation via the Web Browser Interface	175
9.1.1.	The Plug Control Screen - Web Browser Interface	175
9.1.2.	The Plug Group Control Screen - Web Browser Interface	176
9.2.	Operation via the Text Interface	179
9.2.1.	The Plug Status Screen - Text Interface	179
9.2.2.	Switching and Reboot Commands - Text Interface	180
9.2.3.	Applying Commands to Several Plugs - Text Interface	183
9.2.4.	Connecting to Serial Ports - Text Interface	186
9.3.	The Automated Mode	187
9.4.	Manual Operation	188
9.5.	Logging Out of Command Mode	188
10.	SSH Encryption	189
11.	Syslog Messages	191
11.1.	Configuration	191
11.2.	Testing Syslog Configuration	192
12.	SNMP Traps	193
12.1.	Configuration	193
12.2.	Testing the SNMP Trap Function	194
13.	Operation via SNMP	195
13.1.	Elite Managed Power Controller SNMP Agent	195
13.2.	SNMPv3 Authentication and Encryption	195
13.3.	Configuration via SNMP	196
13.3.1.	Viewing Users	197
13.3.2.	Adding Users	197
13.3.3.	Modifying Users	197
13.3.4.	Deleting Users	197
13.4.	Plug Control via SNMP	198
13.4.1.	Controlling Plugs	198
13.4.2.	Controlling Plug Groups	199

13. Operation via SNMP (continued)	
13.5. Viewing Elite Managed Power Controller Status via SNMP	199
13.5.1. Plug Status	199
13.5.2. Unit Environment Status	200
13.5.3. System Environment Status	201
13.6. Sending Traps via SNMP	201
14. Setting Up SSL Encryption	203
14.1. Creating a Self Signed Certificate	204
14.2. Creating a Signed Certificate	207
15. Saving and Restoring Configuration Parameters	209
15.1. Sending Parameters to a File	209
15.2. Restoring Saved Parameters	210
15.3. Restoring Previously Saved Parameters	211
16. Upgrading Firmware	213
17. Command Reference Guide	217
17.1. Command Conventions	217
17.2. Command Summary	218
17.3. Command Set	219
17.3.1. Display Commands	219
17.3.2. Control Commands	221
17.3.3. Configuration Commands	227

Appendices:

A. Interface Descriptions	231
A.1. Serial Console Port (RS232)	231
A.2. RJ-45 AUX Port Interface	232
B. Connecting Devices to AUX & Remote Ports	233
B.1. Connecting an Auxiliary Unit to the AUX Port	233
B.2. Connecting Other RJ-45 DCE Devices to the AUX & Remote Ports	234
C. Rack Mounting	235
C.1. "L" Bracket Mounting	235
C.2. Mounting Buttons	237
C.3. Universal Mounting Bracket	239
D. Troubleshooting	241
D.1. Calling Black Box	241
D.2. Shipping and Packaging	241

1. Specifications

Physical/Environmental:**Models PSH8-S20-120V, PSH8-S20-208+C, PSH8-D20-120V and PSH8-D20-208+V:**

Width: 19" (48.3 cm) (Including Rack Brackets)

Depth: 8.7" (22.1 cm)

Height: 1.75" (4.5 cm) One Rack U

Models PSH16-D20-120V and PSH16-D20-208+V:

Width: 19" (48.3 cm) (Including Rack Brackets)

Depth: 8.7" (22.1 cm)

Height: 3.5" (8.9 cm) Two Rack U

Models PSV20-S20-120V, PSV20-S20-208+V, PSV20-S30-120V, and PSV20-S30-208+V:

Width: 4" (10.2 cm)

Depth: 3.2" (8.1 cm)

Height: 31" (78.7 cm)

Operating Temperature: 32°F to 122°F (0°C to 50°C)

Humidity: 10 - 90% RH

Network Interface: 10/100Base-T Ethernet, RJ45, multi-session Telnet.

Power Outlets:

PSH8-S20-120V: Eight (8) each, NEMA 5-20R Outlets.

PSH8-S20-208+V: Eight (8) each, IEC320-C13 Outlets.

PSH8-D20-120V: Eight (8) each, NEMA 5-20R Outlets.

PSH8-D20-208+V: Eight (8) each, IEC320-C13 Outlets.

PSH16-D20-120V: Sixteen (16) each, NEMA 5-20R Outlets.

PSH16-D20-208+V: Sixteen (16) each, IEC320-C13 Outlets.

PSV20-S20-120V: Twenty (20) each, NEMA 5-20R Outlets.

PSV20-S20-208+V: Twenty (20) each, IEC320-C13 Outlets.

PSV20-S30-120V: Twenty (20) each, NEMA 5-20R Outlets.

PSV20-S30-208+V: Twenty (20) each, IEC320-C13 Outlets.

Power Requirements and Maximum Load:

Model No.	Input Feeds	Input Voltage	Max. Load per Outlet	Max. Load per Input*	Max Load per Unit*
PSH8-S20-120V	1 ea, 20 Amp	100 to 120 VAC	16 Amps	16 Amps	16 Amps
PSH8-S20-208+V	1 ea, 20 Amp	100 to 240 VAC	10 Amps	16 Amps	16 Amps
PSH8-D20-120V	2 ea, 20 Amp	100 to 120 VAC	16 Amps	16 Amps	32 Amps
PSH8-D20-208+V	2 ea, 20 Amp	100 to 240 VAC	10 Amps	16 Amps	32 Amps
PSH16-D20-120V	2 ea, 20 Amp	100 to 120 VAC	16 Amps	16 Amps	32 Amps
PSH16-D20-208+V	2 ea, 20 Amp	100 to 240 VAC	10 Amps	16 Amps	32 Amps
PSV20-S20-120V	1 ea, 20 Amp	100 to 120 VAC	16 Amps	16 Amps	16 Amps
PSV20-S20-208+V	1 ea, 20 Amp	100 to 240 VAC	10 Amps	16 Amps	16 Amps
PSV20-S30-120V	1 ea, 30 Amp	100 to 120 VAC	16 Amps	24 Amps	24 Amps
PSV20-S30-208+V	1 ea, 30 Amp	100 to 240 VAC	10 Amps	24 Amps	24 Amps

* In accordance with UL requirements for branch circuits, this value has been de-rated to 80%.

2. Quick Start Guide

This section describes a simplified installation procedure for the Elite Managed Power Controllers, which will allow you to communicate with the unit in order to demonstrate basic features and check for proper operation.

Note that this Quick Start Guide does not provide a detailed description of unit configuration, or discuss advanced operating features in detail. In order to take full advantage of the features provided, it is recommended that you should complete the Installation and Configuration sections after performing this Quick Start procedure.

2.1. Quick Hardware Installation

2.1.1. Apply Power to the Elite Managed Power Controller

Refer to the warnings and cautions at the beginning of this guide and the power rating nameplate on the back panel, and then connect the unit to an appropriate power source. Connect the power cable(s) to the power inlet(s), install the cable keeper(s), then connect the cables to an appropriate power supply. Refer to the table in the Specifications section for information concerning power requirements and maximum load.

Note:

To determine the exact model number, either refer to the nameplate on the back of the unit, or access command mode and then type /J * and press [Enter].

2.1.2. Connect your PC to the Elite Managed Power Controller

The Elite Managed Power Controller can either be controlled by a local PC, that communicates with the unit via serial port, controlled via external modem, or controlled via TCP/IP network. In order to switch plugs or select parameters, commands are issued to the unit via either the Network Port or Console Port. Note that it is not necessary to connect to both the Network and Console Ports, and that the Console Port can be connected to either a local PC or External Modem.

- **Network Port:** Connect your 10Base-T or 100Base-T network interface to the Elite Managed Power Controller Network port.
- **Console Port:** Use a null modem cable to connect your PC COM port to the Elite Managed Power Controller's serial Console (RS232) Port.
- **External Modem:** Use a standard AT to Modem cable to connect your external modem to the Elite Managed Power Controller's serial Console (RS232) Port.

2.2. Communicating with the Elite Managed Power Controller

When properly configured, the Elite Managed Power Controller will allow command mode access via Telnet, Web Browser, SSH client, modem, or local PC.

Notes:

- **In order to ensure security, both Telnet and Web Browser access are disabled in the default state. To enable Telnet and/or Web Browser access, please refer to Section 5.9.2.**
- **Default serial port parameters are set as follows: 9600 bps, RTS/CTS Handshaking, 8 Data Bits, One Stop Bit, No Parity. Although these parameters can be easily redefined, for this Quick Start procedure, it is recommended to configure your communications program to accept the default parameters.**
- **The Elite Managed Power Controller features a default IP Address (192.168.168.168) and a default Subnet Mask (255.255.255.0.) This allows network access to command mode, providing that you are contacting the unit from a node on the same subnet. When attempting to access the unit from a node that is not on the same subnet, please refer to Section 5.9 for further configuration instructions.**

1. **Access Command Mode:** The Elite Managed Power Controller features two separate user interfaces; the Text Interface and the Web Browser Interface. The Text Interface is available via Local PC, SSH Client, Telnet, or Modem and the Web Browser interface is only available via TCP/IP network.
 - a) **Via Local PC:** Start your communications program and then press **[Enter]**.
 - b) **Via SSH Client:** Start your SSH client, enter the default IP address (192.168.168.168) for the Elite Managed Power Controller and invoke the connect command.
 - c) **Via Web Browser:** Make certain that Web Browser access is enabled as described in Section 5.9.2. Start your JavaScript enabled Web Browser, enter the default Elite Managed Power Controller IP address (192.168.168.168) in the address bar, and then press **[Enter]**.
 - d) **Via Telnet:** Make certain that Telnet access is enabled as described in Section 5.9.2. Start your Telnet client, and enter the Elite Managed Power Controller's default IP address (192.168.168.168).

- e) **Via Modem:** Make certain that the Elite Managed Power Controller's Console Port has been configured for Modem Mode as described in Section 5.8.1, then use your communications program to dial the number for the external Modem connected to the Console Port.
2. **Username / Password Prompt:** A message will be displayed, which prompts you to enter your username (Login) and password.. The default username is "super" (all lower case, no quotes), and the default password is also "super". If a valid username and password are entered, the unit will display either the Main Menu (Web Browser Interface) or the Port Status Screen (SSH, Telnet, or Modem.)
3. **Test Switching Functions:** You may wish to perform the following tests in order to make certain that the unit is responding to commands. When switching and reboot commands are executed, the Status LED(s) will also turn On or Off to indicate the current status of the outlet(s).
 - a) **Reboot Outlet:**
 - i. **Web Browser Interface:** Click on the Plug Control link on the left hand side of the screen to display the Plug Control Menu. From the Plug Control Menu, click the down arrow in the row for Plug A1 to display the dropdown menu, then select Reboot from the drop down menu and click on the Execute Plug Actions button.
 - ii. **Text Interface:** Type `/BOOT A1` and press `[Enter]`.
 - b) **Switch Outlet Off:**
 - i. **Web Browser Interface:** From the Plug Control Menu, click the down arrow in the Action column for Plug A1 to display the drop down menu, then select Off from the drop down menu and click on the Execute Plug Actions button.
 - ii. **Text Interface:** Type `/OFF A1` and press `[Enter]`.
 - c) **Switch Outlet On:**
 - i. **Web Browser Interface:** From the Plug Control Menu, click the down arrow in the Action column for Plug A1 to display the drop down menu, then select On from the drop down menu and click on the Execute Plug Actions button.
 - ii. **Text Interface:** Type `/ON A1` and press `[Enter]`.

3. **Logging Out:** When you log off using the proper command, this ensures that the unit has completely exited from command mode, and is not waiting for the inactivity timeout to elapse before allowing additional connections.
 - a) **Web Browser Interface:** Click on the Logout link on the left hand side of the screen.
 - b) **Text Interface:** Type **/x** and press **[Enter]**.

This completes the Quick Start Guide for the Elite Managed Power Controller. Prior to placing the unit into operation, it is recommended to refer to the remainder of this User's Guide for important information regarding advanced configuration capabilities and more detailed operation instructions. If you have further questions regarding the Elite Managed Power Controller unit, please contact Customer Support.

3. Overview

The Elite Managed Power Controllers allow secure, remote metering and management of AC powered rack mount equipment via SSL, SSH, SNMP, web browser, telnet, external modem or local terminal. The Elite Managed Power Controller can monitor power to your equipment, and automatically notify you when changes in current levels, temperature, circuit breaker status or other factors exceed user-defined threshold values.

The Elite Managed Power Controller features two separate power circuits with up to 20 Amps input feed handling capacity per branch circuit, and is available in a horizontal, rack mount version with eight or sixteen switched outlets, or as a “zero unit” vertical mount model with 20 switched outlets.

Power Metering and Management:

The Elite Managed Power Controller can constantly measure current consumption, temperature levels, ping response and other factors. If the unit detects that user defined thresholds for these values have been exceeded, it can promptly notify you via email, SNMP, Syslog, LED or audible alarm. When temperature and current readings exceed user defined critical values, the unit can also intelligently shed the current load by temporarily shutting down nonessential devices; when readings return to acceptable levels, the unit can restore power to those devices to return to normal operating conditions.

In addition, the Elite Managed Power Controller can also notify you when the Invalid Access Lockout has been triggered, when one of the circuit breakers is open, or when a loss of communication with the optional auxiliary units is detected. The unit also records current consumption data to a convenient log file, which can be retrieved in ASCII, XML, or CSV format or displayed in graph format.

Security and Co-Location Features:

Secure Shell (SSHv2) encryption and address-specific IP security masks help to prevent unauthorized access to command and configuration functions.

The Elite Managed Power Controller also provides four different levels of security for user accounts: Administrator, SuperUser, User and ViewOnly. The Administrator level provides complete access to all plug functions, operating features and configuration menus. The SuperUser level allows switching and rebooting of all plugs but does not allow access to configuration functions. The User level allows access to only a select group of Administrator-defined plugs. The ViewOnly level allows you to check plug status and unit status, but does not allow switching or rebooting of outlets or access to configuration menus.

The Elite Managed Power Controller includes full Radius support, LDAP capability, TACACS capability, DHCP and an invalid access lockout feature. An Audit Log records all user access, login and logout times and command actions.

Convenient, Durable Design:

When additional outlets are needed, each Elite Managed Power Controller unit can be connected to up to three Auxiliary/Remote Elite Managed Power Controller units, allowing control of up to 80 outlets via a single IP Address .

Elite Managed Power Controller Units:

The Elite Managed Power Controller Series includes a variety of horizontal and vertical models to accommodate the power distribution needs of almost any rack mount application.

Model No.	Input Feeds	Input Voltage	Max. Load per Outlet	Max. Load per Input*	Max Load per Unit*
PSH8-S20-120V	1 ea, 20 Amp	100 to 120 VAC	16 Amps	16 Amps	16 Amps
PSH8-S20-208+V	1 ea, 20 Amp	100 to 240 VAC	10 Amps	16 Amps	16 Amps
PSH8-D20-120V	2 ea, 20 Amp	100 to 120 VAC	16 Amps	16 Amps	32 Amps
PSH8-D20-208+V	2 ea, 20 Amp	100 to 240 VAC	10 Amps	16 Amps	32 Amps
PSH16-D20-120V	2 ea, 20 Amp	100 to 120 VAC	16 Amps	16 Amps	32 Amps
PSH16-D20-208+V	2 ea, 20 Amp	100 to 240 VAC	10 Amps	16 Amps	32 Amps
PSV20-S20-120V	1 ea, 20 Amp	100 to 120 VAC	16 Amps	16 Amps	16 Amps
PSV20-S20-208+V	1 ea, 20 Amp	100 to 240 VAC	10 Amps	16 Amps	16 Amps
PSV20-S30-120V	1 ea, 30 Amp	100 to 120 VAC	16 Amps	24 Amps	24 Amps
PSV20-S30-208+V	1 ea, 30 Amp	100 to 240 VAC	10 Amps	24 Amps	24 Amps

* In accordance with UL requirements for branch circuits, this value has been de-rated to 80%.

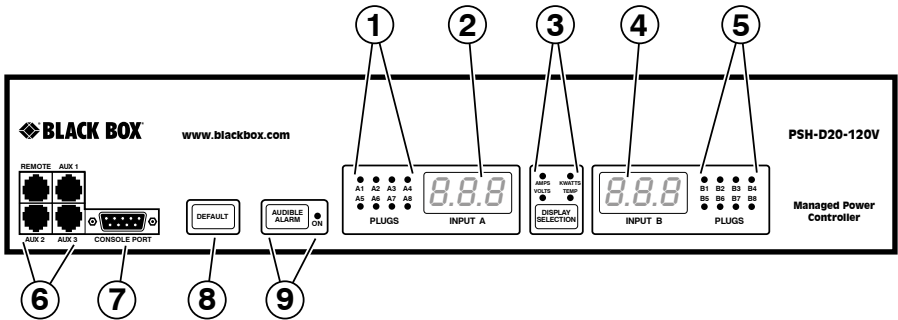

Figure 3-1: Front Panel Components - Model PSH16-D20-120V Shown

3.1. Horizontal Series - Front Panel Components

As shown in Figure 3-1, the Front Panel of Horizontal models includes the following components:

1. **Power Circuit A - Indicator Lights:** LED indicators, which light when power is applied to the corresponding outlet on Power Circuit A.

Note:

PSH8-S20-120V and PSH8-S20-208+V units feature a single power circuit (branch.) Accordingly, PSH8-S20-120V and PSH8-S20-208+V units also include only one set of Indicator lights and only one Digital Display.

2. **Power Circuit A - Digital Display:** An LED digital readout, which can be used to show Amps, Kilowatts, Volts or Temperature for Power Circuit A. Note that the Display Selection Button is used to determine which of these values will appear on the digital display.
3. **Display Selection Button and Indicators:** Determines which measurement will appear on the Digital Displays for Circuits A and B. Each time the Display Selection Button is pressed, the Digital Displays will toggle between Amps, Kilowatts, Volts, Temperature, Total Kilowatts and Total Amps. When either “Total Kilowatts” or “Total Amps” are selected, the Elite Managed Power Controller will display the total for Circuits A and B combined. An LED indicator will light to show which measurement is currently selected. Note that the “Total Kilowatts” and “Total Amps” displays are not available on Horizontal series units. Please refer to Section 3.4 for additional button functions.

4. **Power Circuit B - Digital Display:** Same as Item 2 above, except displays values for Power Circuit B. (Not present on PSH8-S20-120V and PSH8-S20-208+V series units.)
5. **Power Circuit B - Indicator Lights:** Same as Item 1 above, except the LEDs light to indicate On/Off status of Power Circuit B outlets. (Not present on PSH8-S20-120V and PSH8-S20-208+V series units.).
6. **Link Ports:** Four RJ45 connectors, which can be used to link the Elite Managed Power Controller unit to up to three other Elite Managed Power Controller units. This allows control of up to four units (one local unit, plus three remote units) via one IP address. If necessary, the Link Ports can also be reconfigured as RS232 serial ports (as described in Section 5.8.2) to allow communication with attached devices.
7. **Console Port:** A DB9, RS232 serial port (DTE), which can be used for connection to a local terminal or external modem, as described in Section 4. For a description of the Console Port interface, please refer to Appendix A.1.
8. **Default Button:** This button can be used to either reset the unit to default parameters or to perform several other functions, described in Section 3.4.
9. **Audible Alarm Button and LED:** When any of the Alarms discussed in Section 7 are triggered, this LED will light, and the Elite Managed Power Controller will emit an audible alarm signal. To turn off the audible alarm signal, press the Audible Alarm Button once. Please refer to Section 3.4 for additional button functions.

3.2. Horizontal Series - Back Panel

As shown in Figures 3-2 and 3-3, the Elite Managed Power Controller Horizontal Series Back Panel includes the following components:

1. **Power Circuit A - Power Inlet:** An IEC60320-C20 AC inlet which supplies power to Elite Managed Power Controller control functions and the Circuit A outlets. Also includes cable keeper (not shown.)

Note:

PSH8-S20-120V and PSH8-S20-208+V series units feature a single Power Inlet.

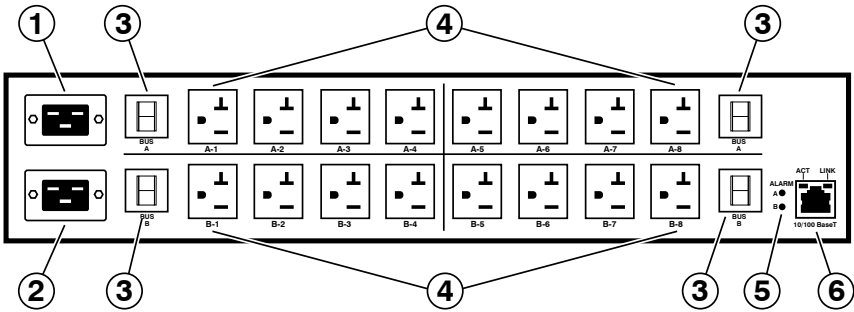

Figure 3-2: Back Panel Components - Model PSH16-D20-120V Shown

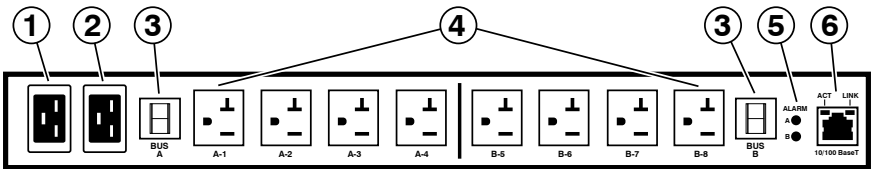

Figure 3-3: Back Panel Components - Model PSH8-D20-120V Shown

2. **Power Circuit B - Power Inlet:** An IEC60320-C20 AC inlet which supplies power to Elite Managed Power Controller control functions and the Circuit B outlets. Also includes cable keeper (not shown.) (Not present on PSH8-S20-120V and PSH8-S20-208+V units.)
3. **Circuit Breaker(s):** Each 20 Amp Circuit Breaker covers four Switched Outlets.
4. **Switched Outlets:** AC Outlets that can be switched On, Off or rebooted in response to user commands. Note that 120V units include NEMA 5-20R outlets and 208+V units include IEC60320-C13 outlets.
5. **Alarm Indicator Lights:** Two LEDs which light when an alarm condition is detected at the corresponding power circuit. For information on Alarm Configuration, please refer to Section 7. Note that PSH8-S20-120V and PSH8-S20-208+V series units include only one Alarm Indicator Light.
6. **Network Port:** An RJ45 Ethernet port for connection to your 100Base-T, TCP/IP network. Note that the Elite Managed Power Controller features a default IP address (192.168.168.168). This allows you to connect to the unit without first assigning an IP address. Note that the Network Port also includes two, small LED indicators for Link and Data Activity. For more information on Network Port configuration, please refer to Section 5.9.

ELITE MANAGED POWER CONTROLLER

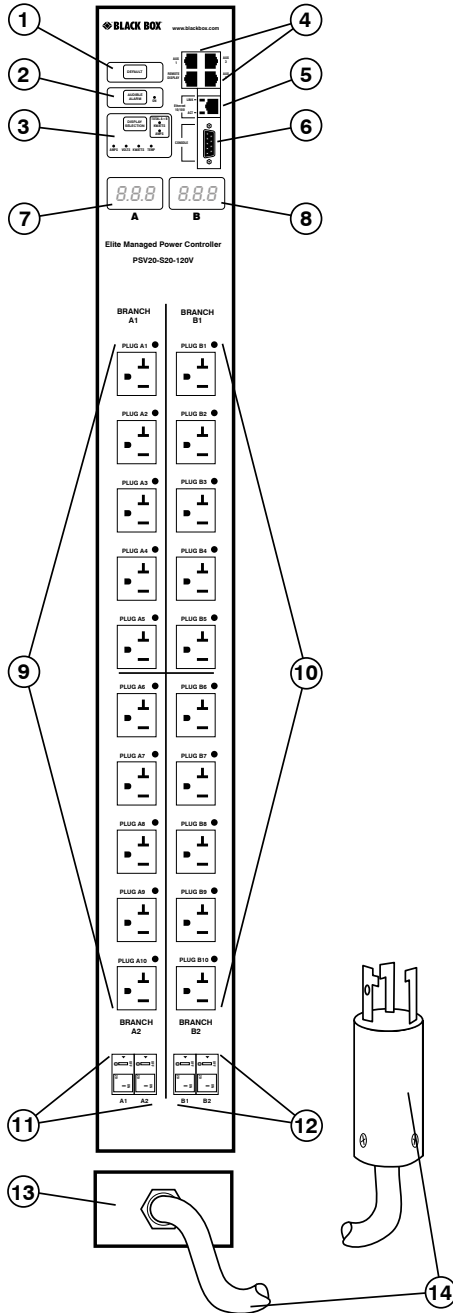

Figure 3-4: Vertical Series Hardware - Model PSV20-S30-120V Shown

3.3. Vertical Series - Hardware Description

As shown in Figure 3-4, Vertical series Elite Managed Power Controller units include the following components:

1. **Default Button:** This button can be used to either reset the unit to default parameters or to perform several other functions, as described in Section 3.4.
2. **Audible Alarm Button and LED:** When any of the Alarms discussed in Section 7 are triggered, this LED will light, and the Elite Managed Power Controller will emit an audible alarm signal. To turn off the audible alarm signal, press the Audible Alarm Button once.
3. **Display Selection Button and Indicators:** Determines which measurement will appear on the Digital Displays for Branches A and B. Each time the Display Selection Button is pressed, the Digital Displays will toggle between Amps, Kilowatts, Volts, Temperature, Total Kilowatts (A+B) and Total Amps (A+B.) Please refer to Section 3.4 for additional button functions.
4. **Link Ports:** Four RJ45 connectors, which can be used to link the Elite Managed Power Controller unit to up to three other Elite Managed Power Controller units, or other network devices. This allows control of up to four units (one local unit, plus three remote units) via one IP address. If necessary, the Link Ports can also be reconfigured as RS232 serial ports (please see Section 5.8) to allow communication with other attached devices.
5. **Network Port:** An RJ45 Ethernet port for connection to your 100Base-T, TCP/IP network. The Elite Managed Power Controller features a default IP address (192.168.168.168). This allows you to connect to the unit without first assigning an IP address. Note that the Network Port also includes two, small LED indicators for Link and Data Activity. For more information on Network Port configuration, please refer to Section 5.9.
6. **Console Port:** A DB9, RS232 serial port (DTE), which can be used for connection to a local terminal or external modem, as described in Section 4.3. For a description of the Console Port interface, please refer to Appendix A.1.
7. **Power Branch A - Digital Display:** An LED digital readout, which can display Amps, Kilowatts, Volts or Temperature readings for Power Branch A or Total Kilowatts or Total Amps for both branches combined.

8. **Power Branch B - Digital Display:** Same as Item 2 above, except displays values for Power Branch B.
9. **Power Branch A - Switched Outlets and Indicator Lights:** AC Outlets that can be switched On, Off or rebooted in response to user commands. Each outlet includes an LED Indicator, which lights when power is applied to the outlet. 120V Models include NEMA 5-20R outlets and 208+V models include IEC60320-C13 outlets.
10. **Power Circuit B - Switched Outlets and Indicator Lights:** Same as Item 9 above, except outlets and LED indicators are for Power Circuit B.
11. **Power Branch A - Circuit Breaker(s):** Circuit Breaker(s) for Power Branch A. Note that PSV20-S20-208+V models and PSV20-S30-208+V models include only one Circuit Breaker per branch.
12. **Power Branch B - Circuit Breaker(s):** Same as Item 11 above.
13. **Unit Bottom Plate:** The bottom plate for PSV20-S20-120V and PSV20-S20-208+V models features an IEC-60320-C20 power cable connector and a detachable power supply cable. The bottom plate on PSV20-S30-120V and PSV20-S30-208+V models features an attached power supply cable.
14. **Power Supply Cable:** PSV20-S20-120V and PSV20-S20-208+V models feature an IEC-60320-C20 power cable connector and a detachable power supply cable (Not Shown.) PSV20-S30-120V and PSV20-S30-208+V models feature an attached power supply cable.

3.4. Additional Button Functions

In addition to the button functions discussed in Sections 3.1, 3.2 and 3.3, the Default, Audible Alarm and Display Selection buttons can also be used to perform several additional functions:

Notes:

- **All Front Panel Button functions can also be disabled via the System Parameters menu, as described in Section 5.3.**
- **When the Elite Managed Power Controller is reset to factory defaults, all user-defined configuration parameters will be cleared, and the default “super” user account will also be restored.**

1. **Reboot Operating System:**
 - a) Press and hold the Default button for five seconds, and then release it.
 - b) The Elite Managed Power Controller will reboot its operating system; all plugs will be left in their current On/Off state.
2. **Set Parameters to Factory Defaults:**
 - a) Simultaneously press both the Default button and the Display Selection button, hold them for five seconds, and then release them.
 - b) All Elite Managed Power Controller parameters will be reset to their original factory default settings, and the unit will then reboot. All plugs will be left in their current On/Off state.
 - c) This function will not be applied to other connected Elite Managed Power Controller units.
3. **Toggle/Default All Plugs:**
 - a) Simultaneously press both the Default button and Audible Alarm button, hold them for five seconds, and then release them.
 - b) The Elite Managed Power Controller will switch all plugs to the Off state. If all plugs are already in the Off state, then the unit will reset all plugs to their user defined default states.
 - c) This function will not be applied to other connected Elite Managed Power Controller units.
4. **Enable/Disable Audible Alarm:**
 - a) In the default state, the Audible Alarm is Enabled.
 - b) To disable the Audible Alarm, press and hold the Audible Alarm button for three seconds and then release it. To enable the Audible Alarm, press and hold the Audible Alarm button for three seconds again.

4. Hardware Installation

4.1. Connecting the Power Supply Cables

4.1.1. Installing the Power Supply Cable Keepers

The Elite Managed Power Controller includes cable keepers, which are designed to prevent the power supply cables from being accidentally disconnected from the unit.

PSH8-D20-120V and PSH8-D20-208+V Models: The cable keepers for these units must be installed by the user.

1. First make certain that both of the two power supply cables are disconnected from the power source.
2. Install the two standoff screws (included with the cable keeper) in the two vacant screw holes, located between the two power inlets. When the standoff screws are in place, thread the two screws supplied with the cable keeper into the top end of both of the standoff screws.
3. Connect the power cables to the power inlets. Check to make sure that both cables are firmly seated in the power inlet connectors.
4. Install the cable keeper plate, by slipping the plate over the two screws which protrude from the top of the standoffs. Slip the cable keeper plate into place, so that the notches in the bottom of the plate slip over the power cables, and the holes in the middle of the plate align with the screws in the tops of the standoffs.
5. Tighten the two screws into the standoffs to secure the plate and the power supply cables to the unit. Check to make certain that the cables are held firmly in place by the cable keepers.

PSH16-D20-120V and PSH16-D20-208+V Models: Sixteen-plug, horizontal units include pre-installed cable keepers. When attaching the power supply cables to the unit, first swing the cable keepers out of the way, then plug the power cables securely into the power inputs. When the cables are in place, snap the cable keepers over each plug to secure the cables to the unit.

PSH8-S20-120V and PSH8-S20-208+V Models: The cable keeper for these units must be installed by the user.

1. First make certain that the power supply cable is disconnected from the power source.

2. Install the two standoff screws (included with the cable keeper) in the two vacant screw holes, located next to the power inlet. When the standoff screws are in place, thread the two screws supplied with the cable keeper into the top end of both of the standoff screws.
3. Connect the power cable to the power inlet. Check to make sure that the cable is firmly seated in the power inlet connector.
4. Install the cable keeper plate, by slipping the plate over the two screws which protrude from the top of the standoffs. Slip the cable keeper plate into place, so that one of the notches in the bottom of the plate slips over the power cable, and the holes in the middle of the plate align with the screws in the tops of the standoffs.
5. Tighten the two screws into the standoffs to secure the plate and the power supply cable to the unit. Check to make certain that the cable is held firmly in place by the cable keeper.

PSV20-S20-120V and PSV20-S20-208+V Models: The cable keepers for the 20-outlet, vertical models must be installed by the user. Note that PSV20-S30-120V and PSV20-S30-208+V (30-Amp) models feature non-detachable power supply cables and do not include cable keepers.

1. First make certain that the Elite Managed Power Controller's power supply cable is disconnected from the power source.
2. Install the screws (included with the cable keeper) in the two vacant screw holes, located directly below the power inlet. Do not overtighten the two screws; leave enough room for the Cable Keeper assembly to be slid into place in Step 4 below.
3. Connect the power cable to the power inlet. Check to make sure that the cable is firmly seated in the power inlet connector.
4. Install the cable keeper plate, by slipping the plate over the two screws that were installed under the power inlets in Step 2 above. Slip the cable keeper into place, so that the notches in the front of the plate slip under the power cables, securing the cables in place.
5. Tighten the two screws to secure the plate and the power supply cables to the unit. Check to make certain that the cables are held firmly in place by the cable keepers.

4.1.2. Connection to the Power Supply

Refer to the cautions listed below and at the beginning of this User's Guide, and then connect the Elite Managed Power Controller unit to an appropriate power supply.

CAUTIONS:

- **Before attempting to install this unit, please review the warnings and cautions listed at the front of the user's guide.**
- **This device should only be operated with the type of power source indicated on the instrument nameplate. If you are not sure of the type of power service available, please contact your local power company.**
- **Reliable earthing (grounding) of this unit must be maintained. Particular attention should be given to supply connections when connecting to power strips, rather than directly to the branch circuit.**

4.2. Connection to Switched Outlets

Connect the power cord from your switched device to one of the AC Outlets on the Elite Managed Power Controller unit. Note that when power is applied, the AC Outlets will be switched "ON" by default.

Note that some Elite Managed Power Controller models feature two separate power busses, while others may feature only one power buss. Please refer to the table shown in Section 1 or Section 3 for more information regarding maximum power and load ratings for your specific Elite Managed Power Controller model.

4.3. Serial Console Port Connection

The Elite Managed Power Controller's Console Port is a male, RS-232C DB9 connector, wired in a DTE configuration. In the default state, the Console port is configured for 9600 bps, no parity, 8 data bits, 1 stop bit. The Console Port can be connected to either an external modem or a local PC, but not both items at the same time. Appendix A.1 describes the Console Port interface.

4.3.1. Connecting a Local PC

Use the supplied null modem cable to connect your PC COM port to the Elite Managed Power Controller's RS232 Console Port. Make certain that the Serial Port Mode is set to "Normal" as described in Section 5.8.1.

4.3.2. Connecting an External Modem

When connecting directly to an external modem, use a standard AT to Modem cable. Make certain that the modem is initialized at the same default parameters as the Elite Managed Power Controller Console Port. Make certain that the Serial Port Mode is set to "Modem" as described in Section 5.8.1.

4.4. Connecting the Network Cable

The Network Port is an RJ45 Ethernet jack, for connection to a TCP/IP network. Connect your 100Base-T cable to the Network Port. Note that the Elite Managed Power Controller includes a default IP address (192.168.168.168) and a default subnet mask (255.255.255.0.) When installing the Elite Managed Power Controller in a working network environment, it is recommended to define network parameters as described in Section 5.9.

4.5. Connecting Additional Units to the AUX Ports

If your application requires control of more outlets than are provided on your Elite Managed Power Controller unit, you can also connect up to three additional Elite Managed Power Controller units to the AUX ports on the Elite Managed Power Controller front panel. This allows you to control up to 80 outlets via a single IP address.

To connect optional, auxiliary units to your local Elite Managed Power Controller, proceed as follows:

1. **Install Snap Adapter:** Insert a DX9F-DTE-RJ snap adapter into the serial console port on the Elite Managed Power Controller unit. For a description of the Snap Adapter interface, please refer to Appendix B.1.
2. **Install RJ-45 Cable:** Connect a straight RJ-45 cable from the AUX port on your local Elite Managed Power Controller unit to the DX9F-DTE-RJ snap adapter, which has been installed in the serial Console port as described above.
3. **Configuration and Operation:** Please refer to Section 5.8.2 for additional configuration instructions for Auxiliary units, and Section 9 for additional operating instructions.

Notes:

- **Once the local Elite Managed Power Controller unit and Auxiliary units have been installed and configured, you must take care when temporarily disconnecting Auxiliary unit(s) from the local unit. Prior to disconnecting Auxiliary units, note the specific AUX port that each Auxiliary unit is initially connected to, and make certain to reconnect each Auxiliary unit to the same AUX port where it was previously connected.**
- **If Auxiliary units are connected to a different AUX port from where they were located when previously configured, then the local Elite Managed Power Controller unit and Auxiliary units must be reconfigured in order to adapt to this change.**
- **When an Auxiliary unit is connected to the AUX port on your local Elite Managed Power Controller unit, the AUX ports on the Auxiliary unit will be automatically disabled.**
- **The AUX ports can also be used for connection to console ports on devices such as servers and other rack mount equipment. For more information, please refer to Appendix B and Section 5.8.2.**

4.6. Rack Mounting

Horizontal Series Units: To install a horizontal format Elite Managed Power Controller unit in your equipment rack, simply attach the L-Brackets included with the unit and then mount the unit in a vacant space in your equipment rack as described in Appendix C.

Vertical Series Units: There are a number of possible rack mounting configurations for vertical format units; vertical units can be mounted in the front or rear of the rack, mounted on the outside of the rack, or mounted in a variety of different makes and models of equipment racks. For a description of the most common rack mounting options available for vertical format units, please refer to Appendix C.

This completes the installation instructions. Please proceed to the next Section for instructions regarding unit configuration.

5. Configuration

This section describes the basic configuration procedure for all Elite Managed Power Controller units. For more information on Reboot Options and Alarm Configuration, please refer to Section 6 and Section 7.

5.1. Communicating with the Elite Managed Power Controller Unit

In order to configure the Elite Managed Power Controller, you must first connect to the unit, and access command mode. Note that, the Elite Managed Power Controller offers two separate configuration interfaces; the Web Browser Interface and the Text Interface.

In addition, the Elite Managed Power Controller also offers three different methods for accessing command mode; via network, via modem, or via local console. The Web Browser interface is only available via network, and the Text Interface is available via network (SSH or Telnet), modem or local PC.

5.1.1. The Text Interface

The Text Interface consists of a series of simple ASCII text menus, which allow you to set options and define parameters by entering the number for the desired option using your keyboard, and then typing in the value for that option.

Since the Web Browser Interface and Telnet accessibility are both disabled in the default state, you will need to use the Text Interface to contact the unit via Local PC or SSH connection when setting up the unit for the first time. After you have accessed command mode using the Text Interface, you can then enable Web Access and Telnet Access, if desired, in order to allow future communication with the unit via Web Browser or Telnet. You will not be able to contact the unit via Web Browser or Telnet until you have specifically enabled those options.

Once Telnet Access is enabled, you will then be able to use the Text Interface to communicate with the Elite Managed Power Controller via local PC, Telnet or SSH connection. You can also use the Text Interface to access command mode via an external modem installed at the Elite Managed Power Controller's serial Console Port.

In order to use the Text Interface, your installation must include:

- **Access via Network:** The Elite Managed Power Controller must be connected to your TCP/IP Network, and your PC must include a communications program (such as HyperTerminal.)
- **Access via Modem:** An external modem must be installed at the Elite Managed Power Controller's RS-232 Console Port, a phone line must be connected to the external modem, and the Console Port must be configured for Modem Mode. In addition, your PC must include a communications program.
- **Access via Local PC:** Your PC must be physically connected to the Elite Managed Power Controller's RS232 Console Port as described in Section 4, the Console Port must be configured for Normal Mode, and your PC must include a communications program.

To access command mode via the Text Interface, proceed as follows:

Note:

When communicating with the unit for the first time, you will not be able to contact the unit via Telnet, until you have accessed command mode, via Local PC or SSH Client, and used the Network Parameters Menu to enable Telnet as described in Section 5.9.

1. Contact the Elite Managed Power Controller Unit:
 - a) **Via Local PC:** Start your communications program and press **[Enter]**. Wait for the connect message, then proceed to Step 2.
 - b) **Via Network:** The Elite Managed Power Controller includes a default IP address (192.168.168.168) and a default subnet mask (255.255.255.0.) This allows you to contact the unit from any network node on the same subnet, without first assigning an IP Address to the unit. For more information, please refer to Section 5.9.
 - i. **Via SSH Client:** Start your SSH client, and enter the Elite Managed Power Controller's IP Address. Invoke the connect command, wait for the connect message, then proceed to Step 2.
 - ii. **Via Telnet:** Start your Telnet Client, and then Telnet to the Elite Managed Power Controller's IP Address. Wait for the connect message, then proceed to Step 2.
 - c) **Via Modem:** Use your communications program to dial the number for the external modem which you have connected to the Elite Managed Power Controller's Console Port.

```

LOCAL - Elite Managed Power Controller Site ID: (undefined)

PLUG |          NAME          | STATUS | BOOT DELAY | DEFAULT | PRIORITY
-----+-----+-----+-----+-----+-----
A1 | Local_InfeedA_Outlet1 | ON    | 0.5 Secs  | ON      | 1
A2 | Local_InfeedA_Outlet2 | ON    | 0.5 Secs  | ON      | 2
A3 | Local_InfeedA_Outlet3 | ON    | 0.5 Secs  | ON      | 3
A4 | Local_InfeedA_Outlet4 | ON    | 0.5 Secs  | ON      | 4
A5 | Local_InfeedA_Outlet5 | ON    | 0.5 Secs  | ON      | 5
A6 | Local_InfeedA_Outlet6 | ON    | 0.5 Secs  | ON      | 6
A7 | Local_InfeedA_Outlet7 | ON    | 0.5 Secs  | ON      | 7
A8 | Local_InfeedA_Outlet8 | ON    | 0.5 Secs  | ON      | 8
A9 | Local_InfeedA_Outlet9 | ON    | 0.5 Secs  | ON      | 9
A10| Local_InfeedA_Outlet10| ON    | 0.5 Secs  | ON      | 10
B1 | Local_InfeedB_Outlet1 | ON    | 0.5 Secs  | ON      | 11
B2 | Local_InfeedB_Outlet2 | ON    | 0.5 Secs  | ON      | 12
B3 | Local_InfeedB_Outlet3 | ON    | 0.5 Secs  | ON      | 13
B4 | Local_InfeedB_Outlet4 | ON    | 0.5 Secs  | ON      | 14
B5 | Local_InfeedB_Outlet5 | ON    | 0.5 Secs  | ON      | 15
B6 | Local_InfeedB_Outlet6 | ON    | 0.5 Secs  | ON      | 16
* = Plug in BUSY state

Enter: <CR> for more plugs, <ESC> to quit ...

```

Figure 5-1: The Plug Status Screen (Text Interface; 20-Plug Unit Shown)

2. **Login / Password Prompt:** A message will be displayed, which prompts you to enter a username (login name) and password. The default username is “super” (all lower case, no quotes), and the default password is also “super”.
3. If a valid username and password are entered, the Elite Managed Power Controller will display the Plug Status Screen, shown in Figure 5-1.

5.1.2. The Web Browser Interface

The Web Browser Interface consists of a series of web forms, which can be used to select configuration parameters and perform reboot operations, by clicking on radio buttons and/or entering text into designated fields.

Note:

In order to use the Web Browser Interface, Web Access must first be enabled via the Text Interface Network Parameters Menu (/N), the Elite Managed Power Controller must be connected to a TCP/IP network, and your PC must be equipped with a JavaScript enabled web browser.

1. Start your JavaScript enabled Web Browser, key the Elite Managed Power Controller’s IP address (default = 192.168.168.168) into the web browser’s address bar, and press **[Enter]**.



Figure 5-2: The Home Screen (Web Browser Interface)

2. **Username / Password Prompt:** A message box will prompt you to enter your username and password. The default username is “super” (all lower case, no quotes), and the default password is also “super”.
3. If a valid username and password are entered, the Elite Managed Power Controller Home Screen will appear as shown in Figure 5-2.

5.1.3. Access Via PDA

In addition to the Web Browser Interface and Text Interface, the Elite Managed Power Controller command mode can also be accessed by PDA devices. Note however, that due to nature of most PDAs, only a limited selection of operating and status display functions are available to users who communicate with the unit via PDA.

When the Elite Managed Power Controller is operated via a PDA device, only the following functions are available:

- Plug Status Screen (Section 8.2)
- Plug Group Status Screen (Section 8.3)
- Plug Control Screen (Section 9.1.1)
- Plug Group Control Screen (Section 9.1.2)
- Current & Power Metering (Section 8.4)
- Current History Graph (Section 8.5)
- Unit Info (Shows Site I.D. message and firmware version.)

For more information on these functions, please refer to the appropriate section listed next to each function in the list above.

These screens will allow PDA users to review Plug Status and Plug Group Status, invoke switching and reboot commands, display Current Metering Readings, show Current History and display the Site I.D. and firmware version. Note however, that PDA users are not allowed to change or review Elite Managed Power Controller configuration parameters.

To configure the Elite Managed Power Controller for access via PDA, first consult your IT department for appropriate settings. Access the command mode via the Text Interface or Web Browser interface as described in this section, then configure the Elite Managed Power Controller's Network Port accordingly, as described in Section 5.9.

In most cases, this configuration will be adequate to allow communication with most PDAs. Note however, that if you wish to use a BlackBerry® to contact the Elite Managed Power Controller, you must first make certain to configure the BlackBerry to support HTML tables, as described below:

1. Power on the BlackBerry, and then click on the BlackBerry Internet Browser Icon.

2. Press the Menu button, and then choose “Options.”
3. From the Options menu, choose “Browser Configuration,” then verify to make certain that “Support HTML Tables” is checked (enabled.)
4. Press the Menu button, and select “Save Options.”

When you have finished communicating with the Elite Managed Power Controller via PDA, it is important to always close the session using the PDA’s menu functions, rather than by simply closing the browser window, in order to ensure that the Elite Managed Power Controller has completely exited from command mode, and is not waiting for the inactivity timeout period to elapse. For example, to close a session on a BlackBerry, press the Menu button and then choose “Close.”

5.2. Configuration Menus

Although the Web Browser Interface and Text Interface provide two separate means for selecting parameters, both interfaces allow access to the same set of basic parameters, and parameters selected via one interface will also be applied to the other. To access the configuration menus, proceed as follows:

- **Text Interface:** Refer to the Help Screen (/H) and then enter the appropriate command to access the desired menu. When the configuration menu appears, key in the number for the parameter you wish to define, and follow the instructions in the resulting submenu.
- **Web Browser Interface:** Click the appropriate link on the left hand side of the screen (see Figure 5-2) to access the desired configuration menu. To change parameters, click in the desired field and key in the new value or select a value from the pull-down menu. To apply newly selected parameters, click on the “Change Parameters” button at the bottom of the menu or the “Set” button next to the field.

The following sections describe options and parameters that can be accessed via each of the configuration menus. Please note that essentially the same set of parameters and options are available to both the Web Browser Interface and Text Interface.

Notes:

- **Configuration menus are only available when you have logged into command mode using a password that permits Administrator Level commands. SuperUser accounts are able to view configuration menus, but are not allowed to change parameters.**
- **Configuration menus are not available when you are communicating with the Elite Managed Power Controller via PDA**
- **When defining parameters via the Text Interface, make certain to press the [Esc] key to completely exit from the configuration menu and save newly defined parameters. When parameters are defined via the Text Interface, newly defined parameters will not be saved until the “Saving Configuration” message has been displayed and the cursor returns to the command prompt.**

5.3. Defining System Parameters

The System Parameters menus are used to define the Site ID Message, set the system clock and calendar, and configure the Invalid Access Lockout feature and Callback feature.

In the Text Interface, the System Parameters menu is also used to create and manage user accounts and passwords. Note however, that when you are communicating with the unit via the Web Browser Interface, accounts and passwords are managed and created via a separate menu that is accessed by clicking on the “Users” link on the left hand side of the menu.

- **Text Interface:** Type **/F** and press **[Enter]**. The System Parameters Menu will appear as shown in Figure 5-3.
- **Web Browser Interface:** Click the “System Parameters” link on the left hand side of the screen. The System Parameters menu will be displayed as shown in Figure 5-4.

```
SYSTEM PARAMETERS:

1. User Directory
2. Site-ID:                (undefined)
3. Real Time Clock:       07/22/2008 15:54:10
4. Invalid Access Lockout: On
5. Command Confirmation:  On
6. Automated Mode:       Off
7. Command Prompt:       EMPC
8. Temperature Format:    Fahrenheit
9. Temperature Calibration (undefined)
10. Voltage Calibration  (undefined)
11. Log Configuration
    21. Audit Log         On - Without Syslog
    22. Alarm Log        On - Without Syslog
    23. Current Metering Log On
12. Callback Security:   On - Callback (Without Password Prompt)
13. Front Panel Buttons  On

Enter: #<CR> to change,
      <ESC> to exit and save configuration ...
```

Figure 5-3: The System Parameters Menu (Text Interface)

The System Parameters Menus are used to define the following:

- **User Directory:** This function is used to view, add, modify and delete user accounts and passwords. As discussed in Section 5.4 and Section 5.5, the User Directory allows you to set the security level for each account as well as determine which plugs each account will be allowed to control.

Note:

The “User Directory” option does not appear in the Web Browser Interface’s System Parameters menu, and is instead, accessed via the “Users” link on the left hand side of the menu.

- **Site ID:** A text field, generally used to note the installation site or name for the Elite Managed Power Controller unit. (Up to 32 chars.; Default = undefined.)

Notes:

- The Site ID cannot include double quotes.
- The Site ID will be cleared if the Elite Managed Power Controller is reset to default settings.

BLACK BOX
NETWORK SERVICES

Firmware version: Version 1.52a
Location: (undefined)

HOME

LOGOUT

STATUS DISPLAYS

PRODUCT STATUS
NETWORK STATUS
PLUG STATUS
PLUG CONTROL
PLUG GROUP STATUS
PLUG GROUP CONTROL
CURRENT METERING
- Current History

POWER METERING
- Power History

LOGS
- Audit Log
- Alarm Log

CONFIGURATION DISPLAYS

GENERAL PARAMETERS
- System Parameters
- Real Time Clock
- Invalid Access Lockout
- Callback Security

SERIAL PORTS

NETWORK CONFIGURATION
- Network Port Parameters
- Network Parameters
- IP Security
- Static Route
- DNS Servers
- SNMP Parameters
- SNMP Traps
- LDAP Parameters
- TACACS
- RADIUS
- Email Messaging

USERS

PLUG GROUP DIRECTORY

PLUG PARAMETERS

REBOOT OPTIONS
- Ping No Answer
- Scheduled Reboot

ALARM CONFIGURATION

System Parameters

Site-ID:

Command Confirmation ▾

Automated Mode ▾

Command Prompt ▾

Temperature Format ▾

Temperature Calibration

Current calibrated temperature: 83 ° (F)
Last reference temperature entered was: None

Voltage Calibration

Current calibrated voltage (A/B): 118 / 119 Volts
Last reference voltage entered was: None

Audit Log ▾

Alarm Log ▾

Current Metering Log ▾

Front Panel Buttons ▾

Figure 5-4: The Systems Parameters Menu (Web Browser Interface)

- **Real Time Clock:** This prompt provides access to the Real Time Clock menu, which is used to set the clock and calendar, and to enable and configure the NTP (Network Time Protocol) feature as described in Section 5.3.1.

Note:

The “Real Time Clock” option does not appear in the Web Browser Interface’s System Parameters menu, and is instead, accessed via the “Real Time Clock” link on the left hand side of the screen.

- **Invalid Access Lockout:** If desired, this feature can be used to automatically disable the Elite Managed Power Controller Console Port or Network Port after a user specified number of unsuccessful login attempts are made. For more information, please refer to Section 5.3.2. (Default = On.)

Note:

The “Invalid Access Lockout” item does not appear in the Web Browser Interface’s System Parameters menu, and is instead, accessed via the link on the left hand side of the screen.

- **Command Confirmation:** Enables/Disables the Command Confirmation feature. When enabled, a “Sure” prompt will be displayed before power switching and reboot commands are executed. When disabled, commands will be executed without further prompting. (Default = On.)
- **Automated Mode:** When enabled, the Elite Managed Power Controller will execute switching and reboot commands without displaying a confirmation prompt, status screen or confirmation messages. For more information, please refer to Section 5.3.3 or Section 9.3. (Default = Off.)

Note:

When this option is enabled, security functions are suppressed, and users are able to access configuration menus and control plugs without entering a password. If security is a concern and the Automated Mode is required, it is recommended to use the IP Security feature (Section 5.9.3) to restrict access.

- **Command Prompt:** Allows the Text Interface command prompt to be set to either “EMPC”, “IPS”, “NPS”, or “NBB.” (Default = EMPC.)

- **Temperature Format:** Determines whether the temperature is displayed as Fahrenheit or Celsius. (Default = Fahrenheit.)
- **Temperature Calibration:** Used to calibrate the unit's internal temperature sensing abilities. To calibrate the temperature, place a thermometer inside your equipment rack, in a location that usually experiences the highest temperature. After a few minutes, take a reading from the thermometer, and then key the reading into the configuration menu. In the Web Browser Interface, the temperature is entered at the System Parameters menu, in the Temperature Calibration field; in the Text Interface, the temperature is entered in a submenu of the System Parameters menu, accessed via the Temperature Calibration item. (Default = undefined.)
- **Voltage Calibration:** This option is used to calibrate the voltage readout on the Elite Managed Power Controller front panel. To calibrate the voltage, first determine the approximate voltage and then select the Voltage Calibration option and key in the correct voltage. In the Web Browser Interface, the voltage is entered at the System Parameters menu in the Voltage Calibration field. In the Text Interface, the voltage is entered in a submenu of the System Parameters menu, which is accessed via the Voltage Calibration item. (Default = undefined.)
- **Audit Log:** Enables/disables the Audit Log, and determines whether or not the Audit Log will send SYSLOG messages to notify you of each logged event. When enabled, the Audit Log will create a record of all power switching and reboot activity at the Elite Managed Power Controller unit, including reboots and switching caused by Load Shedding, Load Shedding Recovery, Ping No Answer Reboots and Scheduled Reboots. For more information on event logging functions, please refer to Section 5.3.4. (Default = On without Syslog.)
- **Alarm Log:** Enables/disables the Alarm Log, and determines whether or not the Alarm Log will send SYSLOG messages to notify you of each logged event. When enabled, the Alarm Log will create a record of all alarm activity at the Elite Managed Power Controller unit. For more information on event logging functions, please refer to Section 5.3.4. (Default = On without Syslog.)

- **Current/Power Log:** Enables/disables Current Metering Log and Power Metering Log. When enabled, the Current Metering Log will create a record of current consumption by each Elite Managed Power Controller branch/circuit and the Power Metering Log will create a record of power consumption (in Kilowatt Hours) versus time. For more information on the event logging functions, please refer to Section 5.3.4. (Default = On).
- **Callback Security:** Enables / configures the Callback Security Function as described in Section 5.3.5. In order for this feature to function, a Callback number must also be defined for each desired user account as described in Section 5.5. (Default = On, Callback, Without Password Prompt.)

Notes:

- **In the Text Interface, Callback Security Parameters are defined via a submenu of the Systems Parameters Menu, which is accessed via the Callback Security item.**
- **In the Web Browser Interface, Callback Security Parameters are defined via a separate menu, which is accessed by clicking the “Callback Security” link on the left hand side of the screen.**
- **Front Panel Buttons:** This item can be used to disable all front panel button functions, including the Display Selection Button and the reinitialization/default functions that are normally available via the Clear and Set buttons on the unit’s front panel, as described in Section 3.4. (Default = On.)

5.3.1. The Real Time Clock and Calendar

The Real Time Clock menu is used to set the Elite Managed Power Controller’s internal clock and calendar. To access the Real Time Clock Menu, proceed as follows:

- **Text Interface:** Type **/F** and press **[Enter]**. The System Parameters menu will appear as shown in Figure 5-3. At the System Parameters menu, type **3** and press **[Enter]** to display the Real Time Clock menu.
- **Web Browser Interface:** Click on the “Real Time Clock” link on the left hand side of the screen to access the Real Time Clock menu.

The configuration menu for the Real Time Clock offers the following options:

- **Date:** Sets the Month, Date, Year and day of the week for the Elite Managed Power Controller's real-time clock/calendar.
- **Time:** Sets the Hour, Minute and Second for the Elite Managed Power Controller's real time clock/calendar. Key in the time using the 24-hour (military) format.
- **Time Zone:** Sets the time zone, relative to Greenwich Mean Time. Note that the Time Zone setting will function differently, depending upon whether or not the NTP feature is enabled and properly configured. (Default = GMT (No DST).)
 - ◆ **NTP Enabled:** The Time Zone setting is used to adjust the Greenwich Mean Time value (received from the NTP server) in order to determine the precise local time for the selected time zone.
 - ◆ **NTP Disabled:** If NTP is disabled, or if the Elite Managed Power Controller is not able to access the NTP server, then status screens and activity logs will list the selected Time Zone and current Real Time Clock value, but will not apply the correction factor to the displayed Real Time Clock value.
- **NTP Enable:** When enabled, the Elite Managed Power Controller will contact an NTP server (defined via the NTP Address prompts) once a day, and update its clock based on the NTP server time and selected Time Zone. (Default = Off.)

Notes:

- **The Elite Managed Power Controller will also contact the NTP server and update the time whenever you change NTP parameters.**
- **To cause Elite Managed Power Controller to immediately contact the NTP server at any time, make certain that the NTP feature is enabled and configured, then type /F and press [Enter]. When the System Parameters menu appears, press [Esc]. The Elite Managed Power Controller will save parameters and then attempt to contact the server, as specified by currently defined NTP parameters.**

- **Primary NTP Address:** Defines the IP address or domain name (up to 64 characters long) for the primary NTP server. (Default = undefined.)

Note:

In order to use domain names for web addresses, DNS Server parameters must first be defined as described in Section 5.9.5.

- **Secondary NTP Address:** Defines the IP address or domain name (up to 64 characters long) for the secondary, fallback NTP Server. (Default = undefined.)

Note:

In order to use domain names for web addresses, DNS Server parameters must be defined as described in Section 5.9.5.

- **NTP Timeout:** The amount of time in seconds, that will elapse between each attempt to contact the NTP server. When the initial attempt is unsuccessful, the Elite Managed Power Controller will retry the connection four times. If neither the primary nor secondary NTP server responds, the Elite Managed Power Controller will wait 24 hours before attempting to contact the NTP server again. (Default = 3 Seconds.)

5.3.2. The Invalid Access Lockout Feature

When properly configured and enabled, the Invalid Access Lockout feature will watch all login attempts made at the Network Port and serial Console Port. If the port exceeds the selected number of invalid attempts, then the port where the Invalid Attempts occurred will be automatically disabled for a user-defined length of time (Lockout Duration.) The Invalid Access Lockout feature uses two separate counters to track invalid access attempts:

- **Serial Port Counter:** Counts invalid access attempts at the RS232 Console Port. If the number of invalid attempts at the port exceeds the user-defined Lockout Attempts value, then the port will be locked.
- **Telnet, SSH and Web Browser Counter:** Counts all invalid attempts to access command mode via Telnet, SSH or Web Browser interface. If the number of cumulative invalid attempts exceeds the user-defined Lockout Attempts value, then the Network Port will be locked.

Note:

In the Web Browser Interface, the Invalid Access Lockout item does not appear in the System Parameters Menu, and is instead accessed via the “Invalid Access Lockout” link on the left hand side of the screen.

Note that when an Invalid Access Lockout occurs, you can either wait for the Lockout Duration period to elapse (after which, the Elite Managed Power Controller will automatically reactivate the port), or you can issue the /UL command (type /UL and press [Enter]) via the Text Interface to instantly unlock all of the Elite Managed Power Controller's logical network ports.

Notes:

- **When the Invalid Access Lockout Alarm has been enabled as described in Section 7.7, the Elite Managed Power Controller can also provide notification via email, Syslog Message, and/or SNMP trap whenever an Invalid Access Lockout occurs.**
- **Invalid Access Lockout parameters, defined via the System Parameters menu, will apply to both the Serial Console Port and the Network Port.**
- **When the Console Port is locked, an external modem connected to that port will not answer.**
- **When either the Console Port or Network Port are locked, the other port will remain unlocked, unless the Invalid Access Lockout feature has also been triggered at that port.**
- **If any one of the Elite Managed Power Controller's logical network ports is locked, all other network connections to the unit will also be locked.**
- **All invalid access attempts at the Elite Managed Power Controller Network Port are cumulative (the count for invalid access attempts is determined by the total number of all invalid attempts at all 16 logical network ports.) If a valid login name/password is entered at any of the logical network ports, then the count for all logical network ports will be restarted.**
- **If the Network Port has been locked by the Invalid Access Lockout feature, it will still respond to the ping command (providing that the ping command has not been disabled at the Network Port.)**

The Invalid Access menus allow you to select the following:

- **Lockout Enable:** Enables/Disables the Invalid Access Lockout feature. (Default = On.)
- **Lockout Attempts:** The number of invalid attempts required in order to activate the Invalid Access Lockout feature. (Default = 9.)
- **Lockout Duration:** The length of time that logical network ports will remain locked when an Invalid Access Lockout occurs. If the duration is set at “Infinite”, then ports will remain locked until the /UL command is issued. (Default = 30 Minutes.)

5.3.3. Automated Mode

The Automated Mode allows the Elite Managed Power Controller to execute switching and reboot commands, without displaying menus or generating response messages. Automated Mode is designed to allow the Elite Managed Power Controller to be controlled by a device which can generate commands to control power switching functions without human intervention.

When Automated Mode is enabled, power switching and reboot commands are executed without a “Sure?” confirmation prompt and without command response messages; the only reply to these commands is the “EMPC>” prompt, which is displayed when each command is completed.

Note that although Automated Mode can be enabled using either the Web Browser Interface or Text Interface, Automated Mode is designed primarily for users who wish to send ASCII commands to the Elite Managed Power Controller without operator intervention, and therefore does not specifically apply to the Web Browser Interface. When Automated Mode is enabled, the Web Browser Interface can still be used to invoke switching and reboot commands.

Notes:

- **When the Automated Mode is enabled, password prompts will not be displayed at login, and you will be able to access Administrator Level command functions (including the configuration menus) and control plugs without entering a password.**
- **If you need to enable the Automated Mode, but want to restrict network access to configuration menus, it is strongly recommended to enable and configure the IP Security Function as described in Section 5.9.3.**

To enable/disable the Automated Mode, go to the System Parameters menu (see Section 5.3,) and then set the “Automated Mode” option to “On”. When Automated Mode is enabled, Elite Managed Power Controller functions will change as follows:

1. **All Password Security Suppressed:** When a user attempts to access command mode, the password prompt will not be displayed at either the Console Port or Network Port. Unless specifically restricted by the IP Security Function, all users will be allowed to access both switching and configuration functions, and all commands will be immediately accepted without the requirement to enter a password.
2. **Status Screen Suppressed:** The plug status screen will not be automatically displayed after commands are successfully executed. Note however, that the /S command can still be invoked to display the status screen as needed.
3. **“Sure?” Prompt Suppressed:** All commands are executed without prompting for user confirmation.
4. **Error Messages Suppressed:** Most error messages will be suppressed. Note however, that an error message will still be generated if commands are invoked using invalid formats or arguments.

All other status display and configuration commands will still function as normal.

5.3.4. Log Configuration

This feature allows you to create records of command activity, alarm actions and current and power consumption for the unit. The Log features are enabled and configured via the System Parameters Menus. The ability to view the Current and Power Metering logs is individually enabled for each account via the User Directory as described in Section 5.5. The Elite Managed Power Controller features four event logs: the Audit Log, the Alarm Log, the Current Metering Log and the Power Metering Log:

- **Audit Log:** The Audit log creates a record of all power switching and reboot activity at the Elite Managed Power Controller unit, including reboots and switching caused by Load Shedding, Load Shedding Recovery, Ping No Answer Reboots and Scheduled Reboots. Each Log record includes a description of the activity that caused the power switching or reboot, the username for the account that initiated the power switching or reboot and the time and date that the power switching or reboot occurred.
- **Alarm Log:** The Alarm log creates a record of all Alarm Activity at the Elite Managed Power Controller unit. Each time an alarm is triggered, the unit will generate a record that lists the time and date of the alarm, the name of the Alarm that was triggered, and a description of the Alarm.
- **Current Metering Log:** The Current Metering Log provides a record of current consumption for the Elite Managed Power Controller unit. Each Log record will include the time and date, current and voltage readings for each available branch circuit and the temperature reading. The Current Metering Log can be downloaded in ASCII, CSV or XML format, and when viewed via the Web Browser Interface, can also be displayed as a graph.
- **Power Metering Log:** The Power Metering Log provides a record of power consumption (in Kilowatt Hours) for the Elite Managed Power Controller unit. The Power Metering Log can be downloaded in ASCII, CSV or XML format, and when viewed via the Web Browser Interface, can also be displayed as a graph.

Note:

If optional Auxiliary Elite Managed Power Controller units have been connected to the AUX ports on your local Elite Managed Power Controller, then the Log Function will also record events that occur at the Auxiliary units too.

5.3.4.1. *The Audit Log and Alarm Log*

The System Parameters menu allows you to select three different configuration parameters for the Audit Log and Alarm Log. Note that the Audit Log and Alarm Log function independently, and parameters selected for one log will not be applied to the other.

- **Off:** The Log is disabled, and command activity and/or alarm events will not be logged.
- **On - With Syslog:** The Log is enabled, and power switching, reboot activity and/or alarm events will be logged. The Elite Managed Power Controller will generate a Syslog Message every time a Log record is created.
- **On - Without Syslog:** The Log is enabled, and power switching, reboot activity and/or alarm events will be logged, but the Elite Managed Power Controller will not generate a Syslog Message every time a Log record is created. (Default Setting.)

Notes:

- **In order for the Audit Log or Alarm Log to generate Syslog Messages, Syslog Parameters must first be defined as described in Section 5.9 and Section 11.1.**
- **The Audit Log will truncate usernames that are longer than 22 characters, and display two dots (..) in place of the remaining characters.**

5.3.4.2. *The Current Metering Log and Power Metering Log*

The System Parameters menu allows you to enable or disable Current Metering and Power Metering. When disabled, the Elite Managed Power Controller will not log current, power, voltage or temperature readings.

5.3.4.3. *Reading and Erasing Logs*

To read the Audit Log, Alarm Log or Current log, access the command mode, then proceed as follows:

- **Text Interface:** Type **/L** and press **[Enter]** to display the Display Log menu. Select the desired Log from the menu, key in the appropriate number and press **[Enter]**, and then follow the instructions in the resulting submenu.
- **Web Browser Interface:** To view the Audit Log, click on the “Audit Log” link on the left hand side of the screen. To view the Alarm Log, click on the “Alarm Log” link on the left hand side of the screen. To view the Current Metering Log, click on the “Current History” link on the left hand side of the screen to access the Current Log Menu and then pick the desired display option from the menu. To view the Power Metering Log, click on the Power History link on the left hand side of the screen to access the Power Log Menu and then pick the desired display option from the menu. The Current Metering Log and Power Metering Log menus allow you to display the Current Log in either graph format, ASCII format, CSS format or XML format.

Notes:

- **You can also display current readings via the Current Metering function. In the Text Interface, type /M and then press [Enter]. In the Web Browser Interface, click on the “Current Metering” link on the left hand side of the screen.**
- **You can also display power readings via the Power Metering function. From the Web Browser Interface, click on the “Power Metering” link on the left hand side of the screen, and then select the desired metering period from the resulting submenu.**

To erase log data, access command mode via the Text Interface, using an account that permits Administrator level commands, then type **/L** and press **[Enter]** to access the Display Logs menu and then proceed as follows:

- **Audit Log:** At the Display Logs menu, type **1** and then press **[Enter]**. When the Audit Log appears, type **E** and press **[Enter]** to erases the Audit Log.
- **Alarm Log:** At the Display Logs menu, type **2** and then press **[Enter]**. When the Alarm Log appears, type **E** and press **[Enter]** to erase the Alarm Log.
- **Current Metering Log:** At the Display Logs menu, type **3** and press **[Enter]**. When the Current Metering Log menu appears, type **4** and press **[Enter]** to erase the Current Metering Log.

Notes:

- **The Elite Managed Power Controller dedicates a fixed amount of internal memory for Audit Log records, and if log records are allowed to accumulate until this memory is filled, memory will eventually “wrap around,” and older records will be overwritten by newer records.**
- **To save the Audit Log or Alarm Log as an ASCII file via the Web Browser Interface, click on the “Logs” link on the left hand side of the screen. When the Logs menu appears, right click the link for the Audit Log or Alarm Log, select “Save Target As”, select text format, and save the document with a “.txt” filename extension.**
- **Note that once records have been erased, they cannot be recovered.**

5.3.5. Callback Security

The Callback function provides an additional layer of security when callers attempt to access command mode via modem. When this function is properly configured, modem users will not be granted immediate access to command mode upon entering a valid password; instead, the unit will disconnect, and dial a user-defined number before allowing access via that number. If desired, users may also be required to re-enter the password after the Elite Managed Power Controller dials back.

In order for Callback Security to function properly, you must first enable and configure the feature via the System Parameters menu as described in this section, and then define a callback number for each desired user account as described in Section 5.5.

To configure and enable the Callback function, proceed as follows:

- **Text Interface:** Type **/F** and press **[Enter]** to access the System Parameters menu, then type **6** and press **[Enter]** to display the Callback Security Menu.
- **Web Browser Interface:** Click the “System Properties” link on the left hand side of the screen to access the System Configuration menu, then click the “Configure Callback Security” link to display the Callback Security Menu.

In both the Text Interface and Web Browser Interface, the Callback Security Menu offers the following options:

- **Callback Enable:** This prompt offers five different configuration options for the Callback Security feature: (Default = On - Callback (Without Password Prompt.)
 - ◆ **Off:** All Callback Security is disabled.
 - ◆ **On - Callback (Without Password Prompt):** Callbacks will be performed for user accounts that include a Callback Number, and the login prompt will not be displayed when the user’s modem answers. If the account does not include a Callback Number, that user will be granted immediate access and a Callback will not be performed.
 - ◆ **On - Callback (With Password Prompt):** Callbacks will be performed for user accounts that include a Callback Number, and the login prompt will be displayed when the user’s modem answers (accounts that include a Callback Number will be required to re-enter their username/password when their modem answers.) If the account does not include a Callback Number, then that user will be granted immediate access and a Callback will not be performed.
 - ◆ **On - Callback ONLY (Without Password Prompt):** Callbacks will be performed for user accounts that include a Callback Number, and the username/password prompt will not be displayed when the user’s modem answers. Accounts that do not include a Callback Number will not be able to access command mode via modem.
 - ◆ **On - Callback ONLY (With Password Prompt):** Callbacks will be performed for user accounts that include a Callback Number, and the username/password prompt will be displayed when the user’s modem answers (users will be required to re-enter their username/password when their modem answers.) Accounts that do not include a Callback Number will not be able to access command mode via modem.

- **Callback Attempts:** The number of times that the Elite Managed Power Controller will attempt to contact the Callback number. (Default = 3 attempts.)
- **Callback Delay:** The amount of time that the Elite Managed Power Controller will wait between Callback attempts. (Default = 30 seconds.)

Notes:

- **After configuring and enabling Callback Security, you must then define a callback phone number for each desired user account (as described in Section 5.5) in order for this feature to function properly.**
- **When using the “On - Callback (With Password Prompt)” option, it is important to remember that accounts that do not include a callback number will be allowed to access command mode without callback verification.**

5.4. User Accounts

Each time you attempt to access command mode, you will be prompted to enter a username (login) and password. The username and password entered at login determine which plug(s) you will be allowed to control and what type of commands you will be allowed to invoke. Each username / password combination is defined within a “user account.”

The Elite Managed Power Controller allows up to 128 user accounts; each account includes a username, password, security level, plug access rights, service access rights and an optional callback number.

5.4.1. Command Access Levels

In order to restrict access to important command functions, the Elite Managed Power Controller allows you to set the command access level for each user account. The Elite Managed Power Controller offers four different access levels: Administrator, SuperUser, User and View Only. The command privileges for each user account are set using the “Access Level” parameter in the Add User or Modify User menus.

Each access level grants permission to use a different selection of commands; lower access levels are restricted from invoking configuration commands, while Administrators are granted access to all commands. The four different access levels can be summarized as follows:

- **Administrator:** Administrators are allowed to invoke all configuration and operation commands, can view all status screens, and can always direct switching and reboot commands to all of the Elite Managed Power Controller’s switched outlets .
- **SuperUser:** SuperUsers are allowed to invoke all power switching and reboot commands and view all status screens. SuperUsers can view configuration menus, but are not allowed to change configuration parameters. SuperUsers are granted access to all outlets.
- **User:** Users are allowed to invoke power switching and reboot commands and view all status screens, but can only apply commands to the outlets that they are specifically granted access to. In addition, Users are not allowed to view configuration menus or change configuration parameters.
- **ViewOnly:** Accounts with ViewOnly access, are allowed to view Status Menus, but are not allowed to invoke reboot and switching commands, and cannot view configurations menus or change configuration parameters. ViewOnly accounts can display the Plug Status screen, but can only view the status of plugs that are specifically allowed by the account.

Section 17.2 summarizes command availability for all four access levels.

In the default state, the Elite Managed Power Controller includes one predefined account that provides access to Administrator commands and allows control of all switched power outlets. The default username for this account is “super” (lowercase, no quotation marks), and the password for the account is also “super”.

Notes:

- **In order to ensure security, it is recommended that when initially setting up the unit, a new user account with Administrator access should be created, and the “super” account should then be deleted.**
- **If the Elite Managed Power Controller is reset to default parameters, all user accounts will be cleared, and the default “super” account will be restored.**

5.4.2. Plug Access

Each account can be granted access to a different selection of switched power outlets (plugs) and plug groups. When accounts are created, the Plug Access parameter and the Plug Group Access parameter in the Add User menu or Modify User menu can be used to grant or deny access to each plug or plug group by that account.

In addition, each command access level also restricts the plugs and plug groups that the account will be allowed to access:

- **Administrator:** Accounts with Administrator access are always allowed to control all plugs and plug groups. Plug access cannot be disabled for Administrator level accounts.
- **SuperUser:** SuperUser accounts allow access to all plugs and plug groups. Port access cannot be disabled for SuperUser accounts.
- **User:** Accounts with User level access are only allowed to issue switching and reboot commands to the plugs and plug groups that have been specifically permitted via the “Plug Access” parameter in the Add User and Modify User menus.
- **ViewOnly:** Accounts with ViewOnly access are not allowed to issue switching and reboot commands to outlets or plug groups. ViewOnly accounts can display the On/Off state of plugs and plug groups, but are limited to the plugs and plug groups specified by the account.

5.4.3. Port Access

The Port Access parameter can be used to grant connection access to the Elite Managed Power Controller's DB-9 Console port, RJ-45 Remote port and AUX ports. Normally, the Console port is used for connection to a local control device such as a laptop, the AUX ports are used for connection to additional remote Elite Managed Power Controller units and the Remote port is used for connection to other DTE devices. If your application requires communication with other devices in the equipment rack the Console port, Remote port and AUX ports can be used for connection to these devices.

Administrator and SuperUser level accounts are always allowed access to the Console Port, and User level accounts can always be granted access to the Console port. Note however, that in order to allow an account to access the AUX ports and Remote port, these ports must first be reconfigured as serial ports as described in Section 5.8.2. When the AUX ports and Remote port are left in their default configuration, accounts will not be allowed to create connections to these ports.

In addition, the command access level will also determine which ports the account will be allowed to access, as summarized below:

- **Administrator and SuperUser:** Accounts with Administrator or SuperUser level command access are always allowed to connect to the Console Port. If the AUX and Remote ports are configured as serial ports, then Administrator and SuperUser level accounts will also be allowed to connect to these ports. Port access cannot be disabled for Administrator and SuperUser level accounts.
- **User:** User level accounts are only allowed to connect to the Console Port when port access has been specifically enabled for the account. If the AUX and Remote ports are configured as serial ports, then User level accounts can also be granted access to these ports.
- **ViewOnly:** Accounts with ViewOnly access are not allowed to create connections to the serial ports.

5.5. Managing User Accounts

The User Directory function is employed to create new accounts, display parameters for existing accounts, modify accounts and delete accounts. Up to 128 different user accounts can be created. The “User Directory” function is only available when you have logged into command mode using an account that permits Administrator commands.

- **Text Interface:** Type **/F** and press **[Enter]** to access the System Parameters Menu. From the System Parameters Menu, type **1** and press **[Enter]** to access the User Directory.
- **Web Interface:** Click the “Users” link on the left hand side of the screen to access the User Directory management menus.

In both the Text Interface and the Web Browser Interface, the user configuration menu offers the following functions:

- **View User Directory:** Displays currently defined parameters for any Elite Managed Power Controller user account as described in Section 5.5.1.
- **Add Username:** Creates new user accounts, and allows you to assign a username, password, command level, plug access plug group access, service access and callback number, as described in Section 5.5.2.
- **Modify User Directory:** This option is used to edit or change account information, as described in Section 5.5.3.
- **Delete User:** Clears user accounts, as described in Section 5.5.4.

Note:

After you have finished selecting or editing user account parameters, make certain to save the new account information before proceeding. In the Web Browser Interface, click on the “Add User” button to save parameters; in the Text Interface, press the [Esc] key several times until the Elite Managed Power Controller displays the “Saving Configuration” message and the cursor returns to the command prompt.

5.5.1. Viewing User Accounts

The “View User Directory” option allows you to view details about each account, including the plugs and plug groups that the account is allowed to control and whether or not the account is allowed to invoke Administrator commands. The View User option will not display actual passwords, and instead, the password field will read “defined”. Note that the View User Accounts function is only available to accounts that permit Administrator Level commands. To view account details, proceed as follows:

- **Text Interface:** From the User Directory menu, type **1** and press **[Enter]**. The Elite Managed Power Controller will display a screen which lists all defined user accounts. Key in the name of the desired account and then press **[Enter]**.
- **Web Browser Interface:** From the User menu, click the “View/Modify User” link. The Elite Managed Power Controller will display a menu that allows you to select the desired user and directory function. Select the “View User” button, and then click on the down arrow, scroll to the desired username, select the username, and then click “Choose User.”

5.5.2. Adding User Accounts

The “Add Username” option allows you to create new accounts and assign usernames, passwords and plug and plug group access rights to each account. Note that the Add User function is only available when you have accessed command mode using a password that permits Administrator Level commands.

To create new user accounts, activate the command mode using an account that permits access to Administrator level commands and then proceed as follows:

- **Text Interface:** Type **/F** and press **[Enter]** to access the System Parameters menu. From the System Parameters Menu, type **1** and press **[Enter]** to display the User Directory Menu. From the User Directory menu, type **2** and press **[Enter]**. The Add User menu (Figure 5-5) will be displayed.
- **Web Browser Interface:** Click the “Users” link to display the User Configuration menu. At the User Configuration menu, click the “Add User” link. The Elite Managed Power Controller will display the Add User menu (Figure 5-6.)

The Add User Menu can define the following parameters for each new account:

- **Username:** Up to 32 characters long, and cannot include non-printable characters. Duplicate usernames are not allowed. (Default = undefined.)

ADD USERNAME TO DIRECTORY:

1. Username: (undefined)
2. Password: (undefined)
3. Access Level: User
4. Port Access: (undefined)
5. Plug Access: (undefined)
6. Plug Group Access (undefined)
7. Service Access Serial Port, Telnet/SSH, Web
8. Current/Power Metering On
9. Callback Phone #: (undefined)

Enter: #<CR> to select,
<ESC> to return to previous menu ...

Figure 5-5: The Add User Menu (Text Interface)

- **Password:** Five to sixteen characters long, and cannot include non-printable characters. Note that passwords are case sensitive. (Default = undefined.)
- **Access Level:** Determines which commands this account will be allowed to access. This option can set the access level for this account to “Administrator”, “SuperUser”, “User” or “ViewOnly.” For more information on Command Access Levels, please refer to Section 5.4.1 and Section 17.2. (Default = User.)
- **Port Access:** If the AUX and/or Remote ports have been reconfigured for use as Serial Ports as described in Section 5.8.2, then this parameter can be used to enable or disable an account’s access to these ports. Normally, when the AUX ports and Remote port are configured for their default purpose the Port Access parameter will have no effect. (Defaults; Administrator and SuperUser = All Serial Ports Enabled, User = All Serial Ports Disabled..)

Notes:

- **This parameter will only function when the AUX ports or Remote port have been configured as serial ports as described in Section 5.8.2.**
- **When the AUX ports are used for connection to additional remote Elite Managed Power Controller units, all accounts will still be able to display status and control switching functions at the remote Elite Managed Power Controller units, providing that access to plugs on the remote units is allowed by the account’s Access Level and Plug Access parameters.**
- **Accounts with ViewOnly level command access cannot be granted access to the serial ports.**

The screenshot displays the Black Box Network Services web browser interface. The top header includes the Black Box logo and 'NETWORK SERVICES' text, with 'Firmware version: Version 1.52a' and 'Location: (undefined)' on the right. A left-hand navigation menu lists various system functions such as 'HOME', 'LOGOUT', 'STATUS DISPLAYS', 'PRODUCT STATUS', 'NETWORK STATUS', 'PLUG STATUS', 'PLUG CONTROL', 'PLUG GROUP STATUS', 'PLUG GROUP CONTROL', 'CURRENT METERING', 'POWER METERING', 'LOGS', 'CONFIGURATION DISPLAYS', 'GENERAL PARAMETERS', 'SERIAL PORTS', 'NETWORK CONFIGURATION', 'USERS', 'PLUG GROUP DIRECTORY', 'PLUG PARAMETERS', 'REBOOT OPTIONS', and 'ALARM CONFIGURATION'. The main content area is titled 'Add User' and contains the following fields and options:

- User Name:
- Password:
- Password Confirm:
- Access Level: (dropdown menu)
- Service Access: Serial Port, Telnet/SSH, Web
- Current/Power Metering: (dropdown menu)
- Callback Phone #:

Below the form are three expandable configuration sections:

- Configure Port Access:
- Configure Plug Access:
- Configure Plug Group Access:

An 'Add User' button is located at the bottom of the form.

Figure 5-6: The Add User Menu (Web Browser Interface)

- **Plug Access:** Determines which outlet(s) this account will be allowed to control. (Defaults; Administrator and SuperUser = All Plugs On, User = All Plugs Off, ViewOnly = All Plugs Off.)

Notes:

- **If your installation includes optional AUX units, please refer to Section 5.5.2.1 for additional instructions regarding granting user account access to plugs on AUX units.**
- **In the Text Interface, Plug Access is configured by selecting item 4 and then selecting the desired plugs from the resulting submenu.**
- **In the Web Browser Interface, Plug Access is configured by clicking on the “plus” symbol to display the drop down menu, and then selecting the desired plugs from the drop down menu.**
- **Administrator and SuperUser level accounts will always have access to all plugs.**
- **User level accounts will only have access to the plugs that are defined via the “Plug Access” parameter.**
- **ViewOnly accounts are allowed to display the On/Off status of plugs via the Plug Status Screen, but are limited to the plugs specified by the account. ViewOnly accounts are not allowed to invoke switching and reboot commands.**
- **Plug Group Access:** Determines which plug groups this account will be allowed to control. Plug Groups allow you to define a selection of outlets, and then quickly assign those outlets to new accounts by allowing the account to access the Plug Group. For more information on Plug Groups, please refer to Section 5.6. (Defaults; Administrator and SuperUser = All Plug Groups On, User = All Plug Groups Off, ViewOnly = All Plug Groups Off.)

Notes:

- In order to use this feature, Plug Groups must first be defined as described in Section 5.6.
 - In the Text Interface, Plug Group Access is configured by selecting item 4 and then selecting the desired Plug Group(s) from the resulting submenu.
 - In the Web Browser Interface, Plug Group Access is configured by clicking on the “plus” symbol to display the drop down menu, and then selecting the desired Plug Group(s) from the drop down menu.
 - Administrator and SuperUser level accounts will always have access to all plug groups.
 - User Level accounts will only have access to the plug groups that are defined via the Plug Group Access parameter.
 - ViewOnly accounts are allowed to display the On/Off status of plug groups via the Plug Status Screen, but are limited to the plug groups specified by the account. ViewOnly accounts are not allowed to invoke switching and reboot commands.
- **Service Access:** Determines whether this account will be able to access command mode via Serial Port, Telnet/SSH or Web. For example, if Telnet/SSH Access is disabled for this account, then this account will not be able to access command mode via Telnet or SSH. (Default = Serial Port = On, Telnet/SSH = On, Web = On.)
- **Current/Power Metering:** Enables/Disables current and power metering for this account. When disabled, this account will not be able to see current or power readings or display current or power history. Note that in order for accounts to be able to display these logs, Current and Power Metering must be enabled via the Systems Parameters menu as described in Section 5.3. (Default = On.)

- **Callback Number:** Assigns a number that will be called when this account attempts to access command mode via modem, and the Callback Security Function has been enabled as described in Section 5.3.5. (Default = undefined.)

Notes:

- If the Callback Number is not defined, then Callbacks will not be performed for this user.
- If the Callback Number is not defined for a given user, and the Callback Security feature is configured to use either of the “On - Callback” options, then that user will be granted immediate access to command mode via modem.
- If the Callback Number is not defined for a given user, and the Callback Security feature is configured to use the “On - Callback ONLY” option, then that user will not be able to access command mode via Modem.
- When using the “On - Callback (With Password Prompt)” option, it is important to remember that accounts that do not include a callback number will be allowed to access command mode without callback verification.
- After you have finished selecting or editing account parameters, make certain to save the new account information before proceeding. In the Web Browser Interface, click on the “Add User” button to save parameters; in the Text Interface, press the [Esc] key several times until the Elite Managed Power Controller displays the “Saving Configuration” message and the cursor returns to the command prompt.

5.5.2.1. Granting User Account Access to Plugs on AUX Units

Web Browser Interface

To grant a user account access to plugs on AUX units, simply select the desired plugs from the “Configure Plug Access” drop down menu as you normally would and then click on the “Add User” button.

Text Interface

When Plug Access for each user account is defined via the Text Interface, the following procedure is used to grant access to plugs on optional AUX/Remote units:

1. From the Add User menu, type **4** and press **[Enter]** to display the Plug Access menu. At the Plug Access menu, select plugs for your local Elite Managed Power Controller unit as you normally would, and when finished, press **[Enter]** to return to the Add User menu.

2. To grant access to plugs on AUX units, type **4** and press **[Enter]** again to return to the Plug Access menu, and then type **>** (greater than symbol) and press **[Enter]** to scroll to the desired AUX Elite Managed Power Controller unit. When the desired AUX unit is displayed, select plugs for the AUX unit as you normally would, and then press **[Enter]** to return to the Add User Menu.

Note:

The first line of the Plug Access menu will indicate the name of the AUX or Local Elite Managed Power Controller unit that is currently selected.

3. Repeat Step 2 above to grant access to plugs on additional AUX units.
4. When you have finished granting Plug Access rights to this user, define any other desired parameters for this account, and then make certain to press **[Esc]** several times until the “Saving Configuration” message is displayed and the unit returns to the command prompt.

5.5.3. Modifying User Accounts

The “Edit User Directory” function allows you to edit existing user accounts in order to change parameters, plug access rights or Administrator Command capability. Note that the Edit/Modify User function is only available when you have accessed command mode using a password that permits Administrator Level commands. To modify a user account, proceed as follows:

- **Text Interface:** From the User Directory menu, type **3** and press **[Enter]**. The Elite Managed Power Controller will display a screen which lists all user accounts. Key in the name of the account you wish to modify, and press **[Enter]**.
- **Web Browser Interface:** From the User Configuration menu, click the “View/Modify User” link. The Elite Managed Power Controller will display a menu that allows you to select the user. Select the “Modify User” button, then click the down arrow, scroll to the name of the desired account, select the username, and then click “Choose User” to display the “Modify User” menu.

Once you have accessed the Modify Users menu, use the menu options to redefine parameters in the same manner that is used for the Add User menu, as discussed in Section 5.5.2.

Note:

After you have finished changing parameters, make certain to save the changes before proceeding. In the Web Browser Interface, click on the “Modify User” button to save parameters; in the Text Interface, press the [Esc] key several times until the Elite Managed Power Controller displays the “Saving Configuration” message.

5.5.4. Deleting User Accounts

This function is used to delete individual user accounts. Note that the Delete User function is only available when you have accessed command mode using a password that permits Administrator Level commands. To delete an existing user account, proceed as follows:

- **Text Interface:** From the Users Directory menu, type **4** and press **[Enter]**. The Elite Managed Power Controller will display a screen which lists all currently defined accounts. Key in the name of the account you wish to delete and press **[Enter]**. The Elite Managed Power Controller will delete the specified account without further prompting.
- **Web Browser Interface:** From the User Configuration menu, click the “View/Modify Users” link. The Elite Managed Power Controller will display a menu that lists all currently defined accounts. Select the “Delete User” box, then click the down arrow, scroll to the account you wish to delete, select the account, and then click “Choose User.” The Elite Managed Power Controller will display a screen that lists details for the specified account; click “Delete User” to confirm deletion.

Notes:

- **Deleted accounts cannot be automatically restored.**
- **The Elite Managed Power Controller allows you to delete the default “super” account, which is included to permit initial access to command mode. Before deleting the “super” account, make certain to create another account that permits Administrator Access. If you do not retain at least one account with Administrator Access, you will not be able to invoke Administrator level commands.**

5.6. The Plug Group Directory

The Plug Group Directory allows you to designate “groups” of plugs that are dedicated to a similar function, and will most likely be switched or rebooted all at the same time or controlled by the same type of user account.

For example, an individual equipment rack might include an assortment of devices that belong to different departments or clients. In order to simplify the process of granting plug access rights to the accounts that will control power to these devices, you could assign all of the plugs for the devices belonging to Department A to a Plug Group named “Dept_A”, and all of the plugs for the devices belonging to Department B to a Plug Group named “Dept_B”. When user accounts are defined later, this would allow you to quickly grant access rights for all of the plugs for the devices belonging to Department A, by merely granting access to the Dept_A Plug Group, rather than by selecting the specific, individual plugs for each Department A user account.

Likewise, Plug Groups allow you to direct On/Off/Boot commands to a series of plugs, without addressing each plug individually. Given the example above, you could quickly reboot all plugs for Department A, by either including the “Dept_A” Plug Group name in a /BOOT command line via the Text Interface, or by using the Plug Group Control menu via the Web Browser Interface.

The Plug Group Directory function is only available when you have logged into command mode using an account that permits Administrator commands. To access the Plug Group Directory, proceed as follows:

- **Text Interface:** Type `/G` and press **[Enter]** to display the Plug Group Directory menu.
- **Web Interface:** Click the “Plug Group Directory” link on the left hand side of the screen to display the Plug Group Directory menu.

In both the Text Interface and the Web Browser Interface, the Plug Group Directory menu offers the following functions:

- **View Plug Group Directory:** Displays currently defined plug access rights for any Elite Managed Power Controller Plug Group as described in Section 5.6.1.
- **Add Plug Group to Directory:** Creates new Plug Groups, and allows you to assign plug access rights to each group as described in Section 5.6.2.
- **Modify Plug Group Directory:** This option is used to edit or change plug access rights for each Plug Group, as described in Section 5.6.3.
- **Delete Plug Group from Directory:** Clears Plug Groups that are no longer needed, as described in Section 5.6.4.

5.6.1. Viewing Plug Groups

The “View Plug Group Directory” option allows you to view the configuration of each Plug Group. Note that the View Plug Group Directory function is only available when you have accessed command mode using a password that permits Administrator Level commands. To view Plug Group details, proceed as follows:

- **Text Interface:** Type **/G** and press **[Enter]** to display the Plug Group Directory menu. From the Plug Group Directory menu, type **1** and press **[Enter]**. The Elite Managed Power Controller will display a screen which lists all defined Plug Groups. Key in the name of the Plug Group that you need to review and then press **[Enter]**.
- **Web Browser Interface:** Click the “Plug Group Directory” link on the left hand side of the screen to display the Plug Group Directory menu. From the Plug Group Directory menu, click the “View/Modify Plug Group” link. The Elite Managed Power Controller will display a menu that allows you to select the desired Plug Group and directory function. Select the “View Plug Group” button, and then click on the down arrow, scroll to the desired Plug Group, select the Plug Group, and then click “Choose Plug Group” to view the selected Plug Group.

ADD PLUG TO GROUP:

1. Plug Group Name: (undefined)

2. Plug Access: (undefined)

Enter: #<CR> to select,
 <ESC> to return to previous menu ...

Figure 5-7: The Add Plug to Group Menu (Text Interface)

The screenshot shows the Black Box Network Services web browser interface. The top header includes the Black Box logo and the text 'Firmware version: Version 1.52a Location: (undefined)'. The left sidebar contains a navigation menu with categories like HOME, LOGOUT, STATUS DISPLAYS, CONFIGURATION DISPLAYS, SERIAL PORTS, NETWORK CONFIGURATION, USERS, and ALARM CONFIGURATION. The main content area displays the 'Add Plug Groups' form, which includes a 'Plug Group Name' input field, a 'Unit LOCAL' label, and a table of plug options. The table has four rows, each with a plug name (Plug A1 to Plug A4) and two columns of checkboxes for 'Local_InfeedA_Outlet' and 'Local_InfeedB_Outlet' (e.g., Plug A1 has checkboxes for Local_InfeedA_Outlet1 and Local_InfeedB_Outlet1). At the bottom of the form is an 'Add Plug Groups' button.

Figure 5-8: The Add Plug Groups Menu (Web Browser Interface)

5.6.2. Adding Plug Groups

The “Add Plug Group to Directory” option allows you to create new Plug Groups and assign plug access rights to each group. Note that the Add Plug Group function is only available when you have accessed command mode using a password that permits Administrator Level commands. To create new Plug Groups, proceed as follows:

- **Text Interface:** Type **/G** and press **[Enter]** to display the Plug Group Directory menu. From the Plug Group Directory menu, type **2** and press **[Enter]**. The Elite Managed Power Controller will display the Add Plug to Group menu as shown in Figure 5-7.
- **Web Browser Interface:** Click the “Plug Group Directory” link on the left hand side of the screen to display the Plug Group Directory menu. From the Plug Group Directory menu, click the “Add Plug Groups” link to display the Add Plug to Group menu as shown in Figure 5-8.

The Add Plug Group Menu can be used to define the following parameters for each new account:

- **Plug Group Name:** Assigns a name to the Plug Group. (Default = undefined.)
- **Plug Access:** Determines which plugs this Plug Group will be allowed to control. (Default = undefined.)

Notes:

- **If your installation includes optional AUX units, please refer to Section 5.6.2.1 for additional instructions regarding granting plug group access to plugs on AUX units.**
- **In the Text Interface, Plug Access is configured by selecting item 2 and then selecting the desired plugs from the resulting submenu.**
- **In the Web Browser Interface, Plug Access is configured by selecting the desired plugs from a list of all plugs in the Add Plug Group menu.**
- **After you have finished defining or editing Plug Group parameters, make certain to save the changes before proceeding. In the Web Browser Interface, click on the “Add Plug Group” button to save parameters; in the Text Interface, press the [Esc] key several times until the Elite Managed Power Controller displays the “Saving Configuration” message and the cursor returns to the command prompt.**

5.6.2.1. Granting User Account Access to Plugs on AUX Units

Web Browser Interface

To grant a plug group access to plugs on AUX units, simply select the desired plugs from the “Add Plug Groups” menu as you normally would and then click on the “Add Plug Groups” button.

Text Interface

When Plug Access for each plug group is defined via the Text Interface, the following procedure is used to grant access to plugs on optional AUX/Remote units:

1. From the Add Plug Group menu, type **2** and press **[Enter]** to display the Plug Access menu. At the Plug Access menu, select plugs for your local Elite Managed Power Controller unit as you normally would, and when finished, press **[Enter]** to return to the Add Plug Group menu.
2. To grant access to plugs on AUX units, type **2** and press **[Enter]** again to return to the Plug Access menu, and then type **>** (greater than symbol) and press **[Enter]** to scroll to the desired AUX Elite Managed Power Controller unit. When the desired AUX unit is displayed, select plugs for the AUX unit as you normally would, and then press **[Enter]** to return to the Add Plug Group Menu.

Note:

The first line of the Plug Access menu will indicate the name of the AUX or Local Elite Managed Power Controller unit that is currently selected.

3. Repeat Step 2 above to grant access to plugs on additional AUX units.
4. When you have finished granting Plug Access rights to this plug group, make certain to press **[Esc]** several times until the “Saving Configuration” message is displayed and the unit returns to the Elite Managed Power Controller command prompt.

5.6.3. Modifying Plug Groups

The “Modify Plug Group” function allows you to edit existing Plug Groups in order to change plug access rights. Note that this function is only available when you have accessed command mode using a password that permits Administrator Level commands. To modify an existing Plug Group , proceed as follows:

- **Text Interface:** Type **/G** and press **[Enter]** to display the Plug Group Directory menu. From the Plug Group Directory menu, type **3** and press **[Enter]**. The Elite Managed Power Controller will display the Modify Plug Group menu.
- **Web Browser Interface:** Click the “Plug Group Directory” link on the left hand side of the screen to display the Plug Group Directory menu. From the Plug Group Directory menu, click the “View/Modify Plug Group” link. The Elite Managed Power Controller will display a menu that lists all currently defined Plug Groups. Select the “Modify Plug Group” button, then click the down arrow, scroll to the Plug Group that you wish to modify, select the Plug Group, and then click “Choose Plug Group.” The Elite Managed Power Controller will display the Modify Plug Group menu.

Once you have accessed the Modify Plug Group menu, use the menu options to redefine parameters in the same manner that is used for the Add Plug Group menu, as discussed in Section 5.6.2.

Note:

After you have finished changing or editing parameters, make certain to save the changes before proceeding. In the Web Browser Interface, click on the “Modify Plug Groups” button to save parameters; in the Text Interface, press the [Esc] key several times until the Elite Managed Power Controller displays the “Saving Configuration” message and the cursor returns to the command prompt.

5.6.4. Deleting Plug Groups

This function is used to delete individual Plug Groups. Note that this function is only available when you have accessed command mode using a password that permits Administrator Level commands. To delete an existing user account, proceed as follows:

- **Text Interface:** Type **/G** and press **[Enter]** to display the Plug Group Directory menu. From the Plug Group Directory menu, type **4** and press **[Enter]**. The Elite Managed Power Controller will display a screen which lists all currently defined Plug Groups. Key in the name of the Plug Group that you wish to delete and press **[Enter]**. The Elite Managed Power Controller will delete the specified account without further prompting.
- **Web Browser Interface:** Click the “Plug Group Directory” link on the left hand side of the screen to display the Plug Group Directory menu. From the Plug Group Directory menu, click the “View/Modify Plug Group” link. The Elite Managed Power Controller will display a menu that lists all currently defined Plug Groups. Select the “Delete Plug Group” button, then click the down arrow, scroll to the Plug Group you wish to delete, select the Plug Group, and then click “Delete Plug Group.” The Elite Managed Power Controller will display a screen that lists details for the specified Plug Group; click “Delete Plug Group” to confirm deletion.

Note:

Deleted accounts cannot be automatically restored.

5.7. Defining Plug Parameters

The Plug Parameters Menu is used to define Plug Names, boot/sequence delay times and Power Up Default values for each of the Elite Managed Power Controller's Switched AC Outlets. Note that this function is only available when you have accessed command mode using a password that permits Administrator Level commands. To define Plug Parameters, proceed as follows:

- **Text Interface:** Type **/PL** and then press **[Enter]**. The Plug Parameters Menu will be displayed as shown in Figure 5-9. To define Plug Parameters, key in the number for the desired parameter, press **[Enter]** and then follow the instructions in the resulting submenu.
- **Web Browser Interface:** Click the "Plug Parameters" link on the left hand side of the screen to display the Plug Group Directory menu (Figure 5-10.) To define Plug Parameters, either place the cursor in the Plug Name field and key in a new name, or locate the drop down menu for the desired parameter, click on the down arrow, and scroll to the desired parameter and select it. When you are finished selecting Plug Parameters, click the "Change Plugs" button to apply the new parameters.

The Plug Parameters Menu allows you to define the following parameters:

- **Plug Name:** (Up to 16 Characters, Default = undefined.)

Note:

Plug Names must begin with either a lower case alphabetic letter or upper case alphabetic letter. Plug Names cannot begin with a number character or symbol character.

PLUG_PARAMETERS - LOCAL

```

1. A1 Plug Name:           Local_InfeedA_Outlet1
2. A1 Boot/Seq. Delay:    0.5 Secs
3. A1 Power Up Default:   On
4. A1 Boot Priority   :    1
5. A2 Plug Name:           Local_InfeedA_Outlet2
6. A2 Boot/Seq. Delay:    0.5 Secs
7. A2 Power Up Default:   On
8. A2 Boot Priority   :    2
9. A3 Plug Name:           Local_InfeedA_Outlet3
10. A3 Boot/Seq. Delay:   0.5 Secs
11. A3 Power Up Default:  On
12. A3 Boot Priority   :    3
13. A4 Plug Name:           Local_InfeedA_Outlet4
14. A4 Boot/Seq. Delay:   0.5 Secs
15. A4 Power Up Default:  On
16. A4 Boot Priority   :    4

```

```

Enter: #<CR> to select, "<" for previous plugs, ">" for next plugs.
      <ESC> to exit and save configuration ...

```

Figure 5-9: The Plug Parameters Menu (Text Interface)

- **Boot/Seq. Delay:** When more than one plug is switched On or a reboot cycle is initiated, the Boot/Sequence delay determines how much time will elapse before the next plug is switched On. When the Boot/Sequence Delay is applied, the Elite Managed Power Controller will wait for the user-defined delay period before switching On the next plug. This allows time for the device connected to the first plug to adequately “wake up” before switching on power to the device connected to the next plug. When Reboot cycles and switching actions are initiated, the Boot/Sequence Delay will be applied as follows:
(Default = 0.5 Second.)

- **Reboot Cycle Delay:** During a reboot cycle, the Elite Managed Power Controller will first switch all selected plugs “Off” (with a 0.5 second pause between each “Off” operation), and then begin to switch selected plugs back On again, pausing for the user-defined Boot/Sequence Delay before switching On the next plug. For example, if the Boot/Sequence Delay for Plug 3 is ten seconds, then the Elite Managed Power Controller will pause for ten seconds before proceeding to the next plug.
- **“On” Sequence Delay:** When two or more plugs are switched On, the Elite Managed Power Controller will pause for the user-defined Boot/Sequence Delay before switching On the next plug.





Firmware version: Version 1.52a
 Location: (undefined)

HOME

LOGOUT

STATUS DISPLAYS

PRODUCT STATUS

NETWORK STATUS

PLUG STATUS

PLUG CONTROL

PLUG GROUP STATUS

PLUG GROUP CONTROL

CURRENT METERING

- Current History

POWER METERING

- Power History

LOGS

- Audit Log

- Alarm Log

CONFIGURATION DISPLAYS

GENERAL PARAMETERS

- System Parameters

- Real Time Clock

- Invalid Access Lockout

- Callback Security

SERIAL PORTS

NETWORK CONFIGURATION

- Network Port Parameters

- Network Parameters

- IP Security

- Static Route

- DNS Servers

- SNMP Parameters

- SNMP Traps

- LDAP Parameters

- TACACS

- RADIUS

- Email Messaging

USERS

PLUG GROUP DIRECTORY

PLUG PARAMETERS

REBOOT OPTIONS

- Ping No Answer

- Scheduled Reboot

ALARM CONFIGURATION

Plug Parameters				
Plug	Plug Name	Boot/Seq. Delay	Power Up Default	Boot Priority
Unit LOCAL				
A1	Local_InfeedA_Outlet1	0.5 Secs ▾	ON ▾	1 ▾
A2	Local_InfeedA_Outlet2	0.5 Secs ▾	ON ▾	2 ▾
A3	Local_InfeedA_Outlet3	0.5 Secs ▾	ON ▾	3 ▾
A4	Local_InfeedA_Outlet4	0.5 Secs ▾	ON ▾	4 ▾
B1	Local_InfeedB_Outlet1	0.5 Secs ▾	ON ▾	5 ▾
B2	Local_InfeedB_Outlet2	0.5 Secs ▾	ON ▾	6 ▾
B3	Local_InfeedB_Outlet3	0.5 Secs ▾	ON ▾	7 ▾
B4	Local_InfeedB_Outlet4	0.5 Secs ▾	ON ▾	8 ▾

Figure 5-10: The Plug Parameters Menu (Web Browser Interface)

- **Power Up Default:** Determines how this plug will react when the Default command (/D) is invoked, or after power to the unit has been interrupted and then restored. After the default command is invoked, or power is restored, the Elite Managed Power Controller will automatically switch each plug On or Off as specified by the Power-Up Default. (Default = On).

Note:

- **If you have accessed command mode using an account that permits Administrator or SuperUser level commands, then the Default command will be applied to all switched plugs.**
 - **If you have accessed command mode using an User Level account, then the Default command will only be applied to plugs allowed by your account.**
- **Boot Priority:** When commands are applied to two or more plugs, the Boot Priority parameter determines the order in which the plugs will be switched On. The Plug that has been assigned a Boot Priority of “1” will always be switched on first, followed by the plug that has been assigned the Boot Priority of “2”, and so forth. When you assign a boot priority to any given plug, then all subsequent plugs will have their priority lowered by one. For more information on the Boot Priority parameter, please refer to Section 5.7.1. (Default = All plugs prioritized according to Plug Number.)

5.7.1. The Boot Priority Parameter

Normally, when an “On” or “Reboot” command is invoked, the Elite Managed Power Controller will switch on its plugs in their default, numeric order. Although in many cases, the default, numeric order will work fine, there are other cases where an individual device (such as a router) must be switched on first, in order to support a second device that will be switched on later.

The Boot Priority Parameter simplifies the process of setting the order in which plugs are switched On, by assigning a priority number to each plug, rather than by requiring the user to make certain that devices are always connected to the Elite Managed Power Controller in a set order. Likewise, when new devices are added to your equipment rack, the Boot Priority Parameter eliminates the need to unplug all existing devices and then rearrange the plugs connected to the unit (and re-define plug parameters) to ensure that they are switched on in the desired order.

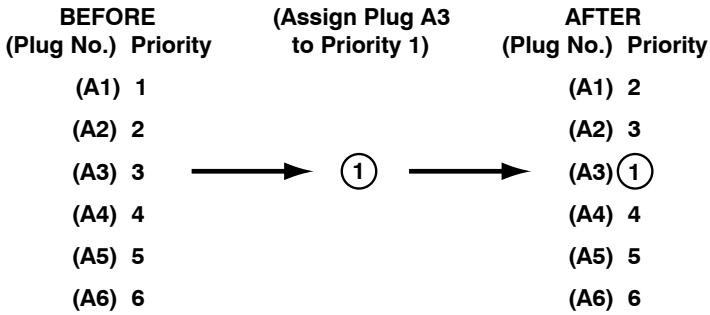

Figure 5-11: Boot Priority Example 1

Notes:

- **No two plugs can be assigned the same Boot Priority number.**
- **When a higher Boot Priority is assigned to any given plug, all subsequent plugs will have their boot priorities lowered by a factor of 1.**
- **The Boot Priority is also displayed on the Plug Status Screen.**

5.7.1.1. Example 1: Change Plug A3 to Priority 1

In the Example shown in Figure 5-11, we start out with all Plugs set to their default Boot Priorities, with Plug A1 first, Plug A2 second and so forth.

Next, the Boot Priority for Plug A3 is changed to Priority 1. This means that Plug A3 will now be switched On first after a reboot, and that Plug A1 will now be switched On second, Plug A2 will be third, etc..

Note that when the Boot Priority for Plug A3 is set to 1, the Boot Priorities for all plugs that were previously Booted before plug A1 are now lowered by a factor of one

BEFORE (Plug No.)	Priority	(Assign Plug A5 to Priority 2)	AFTER (Plug No.)	Priority
(A1)	2		(A1)	3
(A2)	3		(A2)	4
(A3)	1		(A3)	1
(A4)	4		(A4)	5
(A5)	5	→ (2) →	(A5)	(2)
(A6)	6		(A6)	6

Figure 5-12: Boot Priority Example 2

5.7.1.2. Example 2: Change Plug A5 to Priority 2

In the second Example shown in Figure 5-12, we start out with Boot Priorities for the plugs set as they were at the end of Example 1; Plug A3 is first, Plug A1 is second, Plug A2 is third, Plug A4 is fourth, and Plug A6 is sixth.

Next, the Boot Priority for Plug A5 is changed to Priority 2. This means that Plug A3 will continue to be switched on first after a reboot, but now Plug A5 will be switched on second, Plug A3 will be third, Plug A2 will be fourth, Plug A4 will be fifth and Plug A6 will still be sixth.

Once again, note that when the Boot Priority for Plug A5 is set to 2, the Boot Priorities for all plugs that were previously Booted before plug A5 are now lowered by a factor of one

5.8. Serial Port Configuration

The Serial Port Configuration menus allow you to select parameters for the Elite Managed Power Controller's serial Console Port, as well as the Remote Port and AUX Ports.

- **Console Port:** The serial Console Port (Port 1) can be configured for connection to a local PC or Modem or used for connection to serial console ports on other rack equipment. In addition, the Serial Port Configuration menu can also be used to set communications parameters, disable Administrator level commands at the Console Port and also select a number of other Console Port Parameters described in Section 5.8.1.
- **Remote Port:** The RJ45 Remote Port can be used for connection to devices, such as servers and routers. Note however, that if necessary, the Serial Port Configuration menu can also be used to reconfigure the Remote Port as described in Section 5.8.2.
- **AUX Ports:** The RJ45 AUX Ports are normally used for connection to optional remote Elite Managed Power Controller units. This allows you to connect up to three additional units when you need to control additional power outlets via a single IP address. If necessary, the Serial Port Configuration menus can also be used to configure the AUX ports for communications with other serial devices as described in Section 5.8.2.

5.8.1. Console Port Configuration

To configure the Elite Managed Power Controller's serial Console Port, proceed as follows:

- **Text Interface:** Type **/P 1** and then press **[Enter]**. The Port Parameters menu will be displayed as shown in Figure 5-13.
- **Web Browser Interface:** Click the "Serial Port" link on the left hand side of the screen to display the Serial Port Configuration Menu. From the Serial Port Configuration menu, use the dropdown menu to select Port 1 (the Console Port) and then click on the Select Port button to display the Serial Port 1 Configuration Menu, as shown in Figure 5-14.

```

PORT PARAMETERS #01:

COMMUNICATION SETTING                PORT MODE PARAMETERS
1. Baud Rate:                        9600                21. Port Name:                (undefined)
2. Bits/Parity:                      8-None              22. Port Mode:                Normal
3. Stop Bits:                        1                   23. DTR Output:              Pulse
4. Handshake:                        RTS/CTS             24. Modem Params:            ---

GENERAL PARAMETERS
11. Administrator Mode:              Permit
12. Logoff Char:                     ^X
13. Sequence Disc:                   One Char
14. Inact Timeout:                   5 Min
15. Command Echo:                    On
16. Accept Break:                    On

Enter #<CR> to change,
    <ESC> to exit and save configuration...

```

Figure 5-13: The Serial Port Configuration Menu (Text Interface)

The Console Port Configuration menu allows the following parameters to be defined. Note that all of these parameters are available via both the Text Interface and Web Browser Interface, and that parameters selected via one interface are also applied to the other.

Communication Settings:

- **Baud Rate:** Any standard rate from 300 bps to 115.2K bps. (Default = 9600 bps)
- **Bits/Parity:** (Default = 8-None).
- **Stop Bits:** (Default = 1).
- **Handshake Mode:** XON/XOFF, RTS/CTS (hardware), Both, or None. (Default = RTS/CTS).

General Parameters:

- **Administrator Mode:** Permits/denies port access to Administrator and SuperUser level accounts. When enabled (Permit), the port will be allowed to invoke Administrator and SuperUser level commands, providing they are issued by an account that permits them. If disabled (Deny), then accounts that permit Administrator and SuperUser level commands will not be allowed to access command mode via this port. (Default = Permit).

The screenshot displays the Black Box Network Services web interface. The top header includes the Black Box logo and 'NETWORK SERVICES' text, with a world map background. The top right corner shows 'Firmware version: Version 1.52a' and 'Location: (undefined)'. The left sidebar contains a navigation menu with categories: HOME, LOGOUT, STATUS DISPLAYS (including Product Status, Network Status, Plug Status, Plug Control, Plug Group Status, Plug Group Control, Current Metering, and Power Metering), LOGS (Audit Log, Alarm Log), CONFIGURATION DISPLAYS (General Parameters, Serial Ports, Network Configuration, IP Security, Static Route, DNS Servers, SNMP Parameters, SHMP Traps, LDAP Parameters, TACACS, RADIUS, Email Messaging), USERS, Plug Group Directory, Plug Parameters, Reboot Options (Ping No Answer, Scheduled Reboot), and Alarm Configuration. The main content area is titled 'Serial Port 1 Configuration' and contains the following settings:

- Port Name:
- Baud Rate: 9600
- Bits/Parity: 8-None
- Stop Bits: 1
- Handshake Mode: RTS/CTS
- Port Mode: Normal
- Administrator Mode: Permit
- Logoff Character: ~X
- Sequence Disconnect: One Character
- Inactivity Timeout: 5 Min
- Command Echo: On
- Accept Break: On
- Modem Reset String: ATZ
- Modem Init String: AT&C1&D2S0=1&B1&H1&R2
- Modem Hang-Up String:
- Periodic Reset Interval: 15
- DTR Output: Pulse upon Disconnect then go High

A 'Change Serial Parameters' button is located at the bottom of the configuration panel.

Figure 5-10: The Plug Parameters Menu (Web Browser Interface)

- **Logoff Character:** The Logoff Character determines the command(s) or character(s) that must be issued at this port in order to disconnect. Note that the Logoff Character does not apply to Direct Connections. (Default = ^X.)
- **Sequence Disconnect:** Enables/Disables and configures the disconnect command. This item offers the option to disable the Sequence Disconnect, select a one character format or a three character format. (Default = One Character.)
- **Inactivity Timeout:** Enables and selects the Timeout Period for this port. If enabled, the Console Port will disconnect when no additional data activity is detected for the duration of the timeout period. (Default = 5 Minutes.)
- **Command Echo:** Enables or Disables command echo at the Console Port. When disabled, commands that are sent to the Console Port will still be invoked, but the actual keystrokes will not be displayed on your monitor. (Default = On.)
- **Accept Break:** Determines whether the port will accept breaks received from the attached device. When enabled, breaks received at the port will be passed to any port that this port is connected to. When disabled, breaks will be refused at this port. (Default = On.)

Port Mode Parameters:

- **Port Name:** Allows you to assign a name to the Console Port. (Default = undefined.)
- **Port Mode:** The operation mode for this port. (Default = Normal Mode)

Depending on the Port Mode selected, the Elite Managed Power Controller will also display the additional prompts listed below. In the Text Interface, these parameters are accessible via a submenu, which will only be active when the appropriate port mode is selected. In the Web Browser Interface, fields will be “grayed out” unless the corresponding port mode is selected.

- ◆ **Normal Mode:** Allows communication with a local PC and permits access to command mode. When the Normal Mode is selected, the following mode-specific parameter can also be defined:
 - **DTR Output:** Determines how DTR will react when the port disconnects. DTR can be held low, held high, or pulsed for 0.5 seconds and then held high. (Default = Pulse.)
- ◆ **Modem Mode:** Permits access to command mode and simplifies connection to an external modem. Modem Mode ports can perform all functions normally available in Normal Mode, but Modem Mode also allows definition of the following, additional parameters:
 - **Reset String:** Redefines the modem reset string. The Reset String can be sent prior to the Initialization string. (Default = ATZ.)
 - **Initialization String:** Defines a command string that can be sent to initialize a modem to settings required by your application. (Default = AT&C1&D2S0=1&B1&H1&R2)
 - **Hang-Up String:** Although the Elite Managed Power Controller will pulse the DTR line to hang-up an attached modem, the Hang-Up string is often useful for controlling modems that do not use the DTR line. (Default = undefined.)
 - **Periodic Reset Value:** Determines how often the Reset String will be sent to the modem at this port.

Note:

When communicating with the Elite Managed Power Controller via modem, these parameters will not be changed until after you exit command mode and disconnect.

```

AUX PORT PARAMETERS:

REMOTE SETTINGS
1. Port Function:      Remote
2. Baud Rate:         ----
3. Bits/Parity:       ----
4. Stop Bits:         ----
5. Handshake:         ----
6. Inact Timeout:     ----

AUX1 SETTINGS
7. Port Function:     Aux1
8. Baud Rate:         ----
9. Bits/Parity:       ----
10. Stop Bits:        ----
11. Handshake:        ----
12. Inact Timeout:    ----

AUX2 SETTINGS
13. Port Function:    Aux2
14. Baud Rate:        ----
15. Bits/Parity:     ----
16. Stop Bits:        ----
17. Handshake:        ----
18. Inact Timeout:    ----

AUX3 SETTINGS
19. Port Function:    Aux3
20. Baud Rate:        ----
21. Bits/Parity:     ----
22. Stop Bits:        ----
23. Handshake:        ----
24. Inact Timeout:    ----

Enter: #<CR> to change,
      <ESC> to exit and save configuration ...

```

Figure 5-15: The Remote/AUX Port Configuration Menu (Text Interface)

5.8.2. Remote Port and AUX Port Configuration

In most applications, it is not necessary to change the configuration of the Remote Port or AUX Port. If you do not intend to use the Remote or AUX ports, or if you intend to use the Remote Port and AUX Ports for connection to the optional Elite Managed Power Controller-DISPLAY unit and additional Elite Managed Power Controller units, then the factory default settings for these ports will work fine and you will not need to change the configuration of these ports.

Note however, that in addition to their default functions, the Remote and AUX Ports can also be configured to allow serial communication with Console Ports on attached devices. In this case, you must reconfigure the Elite Managed Power Controller's Remote and/or AUX Ports as follows:

- **Text Interface:** Type **/P AUX** and then press **[Enter]**. The Remote/AUX Port Parameters menu will be displayed as shown in Figure 5-15.
- **Web Browser Interface:** Click the “Serial Port” link on the left hand side of the screen. From the Serial Port Configuration menu, use the dropdown menu to select “Aux” and then click on the Select Port button to display the Remote/AUX Port Configuration Menu, as shown in Figure 5-16.

BLACK BOX NETWORK SERVICES Firmware version: Version 1.52a Location: (undefined)

HOME

LOGOUT

STATUS DISPLAYS

- PRODUCT STATUS
- NETWORK STATUS
- PLUG STATUS
- PLUG CONTROL
- PLUG GROUP STATUS
- PLUG GROUP CONTROL
- CURRENT METERING
 - Current History
- POWER METERING
 - Power History
- LOGS
 - Audit Log
 - Alarm Log

CONFIGURATION DISPLAYS

- GENERAL PARAMETERS
 - System Parameters
 - Real Time Clock
 - Invalid Access Lockout
 - Callback Security
- SERIAL PORTS
- NETWORK CONFIGURATION
 - Network Port Parameters
 - Network Parameters
 - IP Security
 - Static Route
 - DNS Servers
 - SNMP Parameters
 - SNMP Traps
 - LDAP Parameters
 - TACACS
 - RADIUS
 - Email Messaging
- USERS
- PLUG GROUP DIRECTORY
- PLUG PARAMETERS
- REBOOT OPTIONS
 - Ping No Answer
 - Scheduled Reboot
- ALARM CONFIGURATION

Aux Port Configuration

Remote Settings		Aux2 Settings	
Port Function:	Remote	Port Function:	Aux2
Baud Rate:	9600	Baud Rate:	9600
Bits/Parity:	8-None	Bits/Parity:	8-None
Stop Bits:	1	Stop Bits:	1
Handshake Mode:	None	Handshake Mode:	None
Inactivity Timeout:	5 Min	Inactivity Timeout:	5 Min

Aux1 Settings		Aux3 Settings	
Port Function:	Aux1	Port Function:	Aux3
Baud Rate:	9600	Baud Rate:	9600
Bits/Parity:	8-None	Bits/Parity:	8-None
Stop Bits:	1	Stop Bits:	1
Handshake Mode:	None	Handshake Mode:	None
Inactivity Timeout:	5 Min	Inactivity Timeout:	5 Min

Change Aux Parameters

Figure 5-16: Remote/AUX Port Configuration Menu (Web Browser Interface)

The Remote/AUX Port Configuration menus allow the following parameters to be defined. Note that all of these parameters are available via both the Text Interface and Web Browser Interface, and that parameters selected via one interface are also applied to the other.

- **Port Function:** Determines whether each port will be used for connection to optional Elite Managed Power Controller devices, or used for serial communication. (Default: Remote Port = “Remote”; AUX Port = “AUX”.)

Notes:

- **In the default state all other Remote/AUX Port parameters are inaccessible. When the Remote/AUX Mode is selected for a port, additional menu items for that port will then be activated.**
- **When the Remote and/or AUX Ports are used for serial communication, Alarms will be temporarily suppressed whenever the ports are connected.**
- **If the AUX port is already connected to an AUX Elite Managed Power Controller unit, then you will need to re-initialize the AUX unit before configuring the AUX port as a serial port. Access your local Elite Managed Power Controller unit via the Text Interface and then issue the /I (initialize) command. When the submenu appears, select the AUX port that you intend to reconfigure as a serial port. After the command is completed, disconnect the AUX Elite Managed Power Controller unit from the AUX port and then reconfigure the AUX port as described in this section.**
- **When an AUX or Remote port is set for Serial Port mode, then accounts that permit access to that port will be allowed to invoke the /C command to connect to the port as described in Section 9.2.4.**
- **Baud Rate:** Any standard rate from 300 bps to 115.2K bps. (Default = 9600 bps)
- **Bits/Parity:** (Default = 8-None)
- **Stop Bits:** (Default = 1)
- **Handshake Mode:** XON/XOFF, RTS/CTS (hardware), Both, or None. (Default = RTS/CTS)
- **Inactivity Timeout:** Enables and selects the Timeout Period for this port. If enabled, the port will disconnect when no additional data activity is detected for the duration of the timeout period. (Default = 5 Minutes.)

```

NETWORK PARAMETERS:

COMMUNICATION SETTING
1. IP Address:      207.212.30.80
2. Subnet Mask:    255.255.255.0
3. Gateway Addr:   207.212.30.1
4. DHCP:           Off
5. IP Security:    Off
6. Static Route:   Off
7. DNS Servers:    (undefined)

SERVERS AND CLIENTS
21. Telnet Access: On
22. SSH Access:    On
23. Web Access:    On
24. SYSLOG Addr:   Off
25. SNMP Access:   Off
26. SNMP Trap:     Off
27. LDAP:          Off
28. TACACS:        Off
29. RADIUS:        Off
30. PING Access:   On
31. Multiple Logins: On
32. Email Messaging: Off

GENERAL PARAMETERS
11. Administrator Mode: Permit
12. Logoff Char:      ^X
13. Sequence Disc:   One Char
14. Inact Timeout:   Off
15. Command Echo:    On
16. Accept Break:    On

Enter: #<CR> to change,
      <ESC> to exit and save configuration ...
    
```

Figure 5-17: The Network Parameters Menu (Text Interface)

5.9. Network Configuration

The Network Parameters Menus are used to select parameters and options for the Network Port and also allow you to implement IP Security features, which can restrict access based on the user’s IP Address.

Although the Web Browser Interface and Text Interface allow definition of essentially the same parameters, parameters are arranged differently in the two interfaces. In the Text Interface, most network parameters are defined via one menu. But in the Web Browser Interface, network parameters are divided into separate menus as described in this section.

To access the Network Parameters Menus, proceed as follows:

- **Text Interface:** Type **/N** and press **[Enter]**. The Network Parameters Menu shown in Figure 5-17 will be displayed.
- **Web Browser Interface:** Click on the “Network Configuration” link on the left hand side of the screen. The Elite Managed Power Controller will display the Network Configuration menu shown in Figure 5-18, which allows you to access the various submenus used to configure the network port.

The screenshot displays the Black Box Network Services web browser interface. The top header includes the Black Box logo and 'NETWORK SERVICES' on the left, and 'Firmware version: Version 1.52a' and 'Location: (undefined)' on the right. The main content area is divided into a left sidebar and a central menu.

Left Sidebar (Navigation Menu):

- HOME
- LOGOUT
- STATUS DISPLAYS**
 - PRODUCT STATUS
 - NETWORK STATUS
 - PLUG STATUS
 - PLUG CONTROL
 - PLUG GROUP STATUS
 - PLUG GROUP CONTROL
 - CURRENT METERING
 - Current History
 - POWER METERING
 - Power History
 - LOGS
 - Audit Log
 - Alarm Log
- CONFIGURATION DISPLAYS**
 - GENERAL PARAMETERS
 - System Parameters
 - Real Time Clock
 - Invalid Access Lockout
 - Callback Security
 - SERIAL PORTS
 - NETWORK CONFIGURATION
 - Network Port Parameters
 - Network Parameters
 - IP Security
 - Static Route
 - DNS Servers
 - SNMP Parameters
 - SNMP Traps
 - LDAP Parameters
 - TACACS
 - RADIUS
 - Email Messaging
 - USERS
 - PLUG GROUP DIRECTORY
 - PLUG PARAMETERS
 - REBOOT OPTIONS
 - Ping No Answer
 - Scheduled Reboot
 - ALARM CONFIGURATION

Central Menu (Network Configuration):

- Network Configuration**
 - [Network Port Parameters](#)
 - [Network Parameters](#)
 - [IP Security](#)
 - [Static Route](#)
 - [DNS Servers](#)
 - [SNMP Parameters](#)
 - [SNMP Traps](#)
 - [LDAP Parameters](#)
 - [TACACS Parameters](#)
 - [RADIUS Parameters](#)
 - [Email Messaging](#)

Figure 5-18: Network Configuration Menu (Web Browser Interface)

Notes:

- **Settings for network parameters depend on the configuration of your network. Please contact your network administrator for appropriate settings.**
- **The Network Parameters Menu selects parameters for all 16 logical Network Ports.**
- **When a new IP Address is selected, or the status of the DHCP feature is changed, the unit will disconnect and reconfigure itself with the new values when you exit the Network Parameters Menu. When configuring the unit via Web or Telnet, make certain your DHCP server is set up to assign a known, fixed IP address in order to simplify reconnection to the unit after the new address has been assigned.**
- **The Network Parameters menu is only available when you have logged into command mode using an account and port that permit Administrator level commands (Supervisor Mode enabled.)**

The Network Parameters menu allows you to define the parameters discussed in the following sections. Note that although the descriptions of network parameters are arranged according to the Web Browser Interface, in the Text Interface, most parameters are included in a single menu.

5.9.1. Network Port Parameters

In the Text Interface, these parameters are found in the main Network Configuration menu (Figure 5-17.) In the Web Browser Interface, these parameters are found by clicking the “Network Port Parameters” link on the left hand side of the screen to display the Network Port Configuration Menu.

- **Administrator Mode:** Permits/denies port access to accounts that allow Administrator or SuperUser level commands. When enabled (Permit), the port will be allowed to invoke Administrator and SuperUser level commands, providing they are issued by an account that permits them. If disabled (Deny), then accounts that permit Administrator and SuperUser level commands will not be allowed to access command mode via this port. (Default = Permit)
- **Logoff Character:** Defines the Logoff Character for this port. This determines which command(s) must be issued at this port in order to disconnect from a second port. (Default = ^X ([Ctrl] plus [X]).)

Note:

The Sequence Disconnect parameter can be used to pick a one character or a three character logoff sequence.

- **Sequence Disconnect:** Enables/Disables and configures the Resident Disconnect command. Offers the option to either disable the Sequence Disconnect, or select a one character, or three character command format. (Default = One Character).

Notes:

- **The One Character Disconnect is intended for situations where the destination port should not receive the disconnect command. When the Three Character format is selected, the disconnect sequence will pass through to the destination port prior to breaking the connection.**
- **When Three Character format is selected, the Resident Disconnect uses the format “[Enter]LLL[Enter]”, where L is the selected Logoff Character.**
- **Inactivity Timeout:** Enables and selects the Inactivity Timeout period for the Network Port. If enabled, and the port does not receive or transmit data for the specified time period, the port will disconnect. (Default = 5 Minutes).
- **Command Echo:** Enables or Disables the command echo for the Network Port. (Default = On).
- **Accept Break:** Determines whether the port will accept breaks received from the attached device, and pass them along to a connected port. When enabled, breaks received at this port will be passed to any port this port is connected to, and sent to the device connected to the other port. When disabled, breaks will be refused at this port. (Default = On.)
- **Multiple Logins:** If the Elite Managed Power Controller is installed in an environment that does not include communication via an open network (local communication only), then the Multiple Logins parameter can be used to determine whether or not multiple users will be able to communicate with the unit at the same time. If this parameter is set to “Off” then only one user will be allowed to communicate with the unit at a time. (Default = On.)

Note:

The “Multiple Logins” prompt is not included in the Web Browser Interface.

5.9.2. Network Parameters

In the Text Interface, these parameters are accessed via the Network Configuration menu (Figure 5-17.) In the Web Browser Interface, these parameters can be found by clicking the “Network Parameters” link on the left hand side of the screen to display the Network Parameters menu.

- **IP Address:** (Default = 192.168.168.168.)
- **Subnet Mask:** (Default = 255.255.255.0.)
- **Gateway Address:** (Default = undefined.)
- **DHCP:** Enables/Disables Dynamic Host Configuration Protocol. When this option is “On”, the Elite Managed Power Controller will perform a DHCP request. Note that in the Text Interface, the MAC address for the Elite Managed Power Controller is listed on the Network Status Screen. (Default = Off.)

Note:

Before configuring this feature via Telnet or Web, make certain your DHCP server is set up to assign a known, fixed IP address. You will need this new IP address in order to reestablish a network connection with the Elite Managed Power Controller unit.

- **Telnet Access:** Enables/disables Telnet access. When Telnet Access is “Off,” users will not be allowed to establish a Telnet connection to the unit. (Default = On.)
- **Telnet Port:** Selects the TCP/IP port number that will be used for Telnet connections. Note that in the Text Interface, this item is defined via a submenu, which is displayed when the Telnet Access parameter is selected (item number 21.) (Default = 23.)
- **SSH Access:** Enables/disables SSH communication. (Default = On.)
- **SSH Port:** Selects the TCP/IP port number that will be used for SSH connections. Note that in the Text Interface, this option is defined via a submenu that is displayed when the SSH Access parameter is selected (item number 22). (Default = 22.)
- **HTTP Access (Web Access):** Enables/disables the Web Browser Interface. When disabled, users will not be allowed to contact the unit via the Web Browser Interface. (Default = Off.)

- **HTTP Port:** Selects the TCP/IP port number that will be used for SSH connections. (Default = 80.)
- **HTTPS Access:** Enables/disables HTTPS communication. For instructions on setting up SSL encryption, please refer to Section 14. (Default = On.)
- **HTTPS Port:** Selects the TCP/IP port number that will be used for HTTPS connections. (Default = 443.)

Notes:

- **In the Text Interface, HTTP and HTTPS parameters reside in a separate submenu. To enable and configure HTTP and HTTPS Access via the Text Interface, access the Network Configuration Menu as described in Section 5.9, then type 23, press [Enter] and use the resulting submenu (Figure 14-1) to select parameters.**
- **When the Web Access parameter is accessed via the Text Interface, the resulting submenu will also allow you to select SSL (encryption) parameters as described in Section 14.**
- **SYSLOG Address:** The IP Address or domain name (up to 64 characters) for the Syslog Daemon that will receive log records generated by the Elite Managed Power Controller. For more information, please refer to Section 11. (Default = undefined.)
- **Ping Access:** Enables/Disables response to the ping command. When Disabled, the Elite Managed Power Controller will not respond to Ping commands. Note that disabling Ping Access at the Network Port will not effect the operation of the Ping-No-Access Alarm. (Default = On.)

5.9.3. IP Security

The IP Security feature allows the Elite Managed Power Controller to restrict unauthorized IP addresses from establishing inbound Telnet connections to the unit. This allows you to grant Telnet access to only a specific group of IP addresses, or block a particular IP address completely. In the default state, the Elite Managed Power Controller accepts incoming IP connections from all hosts.

In the Text Interface, IP Security parameters are defined via item 5 in the Network Configuration menu (Figure 5-17.) In the Web Browser Interface, these parameters are found by clicking the “IP Security” link on the left hand side of the screen. In the default state, IP Security is disabled.

The IP Security Function employs a TCP Wrapper program which allows the use of standard, Linux operators, wild cards and net/mask pairs to create a host based access control list.

The IP Security configuration menus include “hosts.allow” and “hosts.deny” client lists. Basically, when setting up IP Security, you must enter IP addresses for hosts that you wish to allow in the Allow list, and addresses for hosts that you wish to deny in the Deny list. Since Linux operators, wild cards and net/mask pairs are allowed, these lists can indicate specific addresses, or a range of addresses to be allowed or denied.

When the IP Security feature is properly enabled, and a client attempts to connect, the Elite Managed Power Controller will perform the following checks:

1. If the client’s IP address is found in the “hosts.allow” list, the client will be granted immediate access. Once an IP address is found in the Allow list, the Elite Managed Power Controller will not check the Deny list, and will assume you wish to allow that address to connect.
2. If the client’s IP address is not found in the Allow list, the Elite Managed Power Controller will then proceed to check the Deny list.
3. If the client’s IP Address is found in the Deny list, the client will not be allowed to connect.
4. If the client’s IP Address is not found in the Deny list, the client will be allowed to connect, even if the address was not found in the Allow list.

Notes:

- **If the Elite Managed Power Controller finds an IP Address in the Allow list, it will not check the Deny list, and will allow the client to connect.**
- **If both the Allow and Deny lists are left blank, then the IP Security feature will be disabled, and all IP Addresses will be allowed to connect (providing that the proper password and/or SSH key is supplied.)**
- **When the Allow and Deny lists are defined, the user is only allowed to specify the Client List; the Daemon List and Shell Command cannot be defined.**

5.9.3.1. Adding IP Addresses to the Allow and Deny Lists

To add an IP Address to the Allow or Deny list, and begin configuring the IP Security feature, proceed as follows.

Notes:

- Both the Allow and Deny list can include Linux operators, wild cards, and net/mask pairs.
- In some cases, it is not necessary to enter all four “digits” of the IP Address. For example, if you wish to allow access to all IP addresses that begin with “192,” then you would only need to enter “192.”
- The IP Security Configuration menu is only available when the Administrator Mode is active.

1. Access the IP Security Configuration Menu.
 - a) **Text Interface:** Type **/N [Enter]** to display the Network Configuration Menu. From the Network Configuration Menu, type **5 [Enter]** to display the IP Security Menu.
 - b) **Web Browser Interface:** Click on the “IP Security” Link on the left hand side of the screen to display the IP Security Menu shown.
2. **Allow List:** Enter the IP Address(es) for the clients that you wish to allow. Note that if an IP Address is found in the Allow list, the client will be allowed to connect, and the Elite Managed Power Controller will not check the Deny list.
 - a) **Text Interface:** Note the number for the first empty field in the Allow list, then type that number at the command prompt, press **[Enter]**, and then follow the instructions in the resulting submenu.
 - b) **Web Browser Interface:** Place the cursor in the first empty field in the parameters menu, then key in the desired IP Address, operators, wild cards, and/or net/mask pairs.
3. **Deny List:** Enter the IP Address(es) for the clients that you wish to deny. Note that if the client’s IP Address is not found in the Deny List, that client will be allowed to connect. Use the same procedure for entering IP Addresses described in Step 2 above.

5.9.3.2. *Linux Operators and Wild Cards*

In addition to merely entering a specific IP address or partial IP address in the Allow or Deny list, you may also use any standard Linux operator or wild card. In most cases, the only operator used is “EXCEPT” and the only wild card used is “ALL,” but more experienced Linux users may note that other operators and wild cards may also be used.

EXCEPT:

This operator creates an exception in either the “allow” list or “deny” list. For example, if the Allow list includes a line which reads:

192 . EXCEPT 192 .255 .255 .6

Then all IP address that begin with “192.” will be allowed; except 192.255.255.6 (providing that this address appears in the Deny list.)

ALL:

The ALL wild card indicates that all IP Addresses should be allowed or denied. When ALL is included in the Allow list, all IP addresses will be allowed to connect; conversely, if ALL is included in the Deny list, all IP Addresses will be denied (except for IP addresses listed in the Allow list.) For example, if the Deny list includes a line which reads:

ALL EXCEPT 168 .255 .192 .192

Then all IP addresses except 168.255.192.192 will be denied (except for IP addresses that are listed in the Allow list.)

Net/Mask Pairs:

An expression of the form “n.n.n.n/m.m.m.m” is interpreted as a “net/mask” pair. A host address is matched if “net” is equal to the bitwise AND of the address and the “mask.” For example, the net/mask pattern “131.155.72.0/255.255.254.0” matches every address in the range “131.155.72.0” through “131.155.73.255.”

5.9.3.3. IP Security Examples

1. **Mostly Closed:** Access is denied by default and the only clients allowed, are those explicitly listed in the Allow list. To deny access to all clients except 192.255.255.192 and 168.112.112.05, the Allow and Deny lists would be defined as follows:
 - Allow List:
 1. 192.255.255.192
 2. 168.112.112.05
 - Deny List:
 1. ALL
2. **Mostly Open:** Access is granted by default, and the only clients denied access, are those explicitly listed in the Deny list, and as exceptions in the Allow list. To allow access to all clients except 192.255.255.192 and 168.112.112.05, the Allow and Deny lists would be defined as follows:
 - Allow List:
 1. ALL EXCEPT 192.255.255.192, 168.112.112.05
 - Deny List:
 1. 192.255.255.192, 168.112.112.05

Notes:

- **When defining a line in the Allow or Deny list that includes several IP addresses, each individual address is separated by either a space, a comma, or a comma and a space as shown in Example 2 above.**
- **Take care when using the “ALL” wild card. When ALL is included in the Allow list, it should always include an EXCEPT operator in order to allow the unit to proceed to the Deny list and determine any addresses you wish to deny.**

5.9.4. Static Route

The Static Route menu allows you to type in Linux routing commands that will be automatically executed each time the unit powers up or reboots. In the Text Interface, the Static Route menu is accessed via item 6 in the Network Configuration menu. In the Web Browser Interface, the Static Route menu is accessed by clicking the Static Route link, located on the left-hand side of the screen.

To access the Static Route Menus, proceed as follows:

- **Text Interface:** Type **/n** and press **[Enter]** to display the Network Parameters Menu (Figure 5-17.) At the Network Parameters Menu, type **6** and press **[Enter]** to display the Static Route Menu.
- **Web Browser Interface:** Click on the “Static Route” link on the left hand side of the screen to display the Static Route Menu.

5.9.5. Domain Name Server

The DNS menu is used to select IP addresses for Domain Name Servers. When web and network addresses are entered, the Domain Name Server interprets domain names (e.g., www.yourcompanyname123.com), and translates them into IP addresses. Note that if you don’t define at least one DNS server, then IP addresses must be used, rather than domain names.

To access the Domain Name Server Menu, proceed as follows:

- **Text Interface:** Type **/n** and press **[Enter]** to display the Network Parameters Menu (Figure 5-17.) At the Network Parameters Menu, type **7** and press **[Enter]** to display the Domain Name Server menu.
- **Web Browser Interface:** Click on the “DNS Server” link to display the Domain Name Server menu.

5.9.6. SNMP Access Parameters

These menus are used to select access parameters for the SNMP feature. To define or change SNMP MIB parameters, proceed as follows:

- **Text Interface:** Type **/N** and press **[Enter]** to display the Network Parameters Menu (Figure 5-17.) At the Network Parameters Menu, type **25** and press **[Enter]** to display the SNMP Access Parameters Menu.
- **Web Browser Interface:** Click on the “SNMP Parameters” link on the left hand side of the screen to display the SNMP Access Parameters Menu.

Note:

After you have configured SNMP Access Parameters, you will then be able to manage the Elite Managed Power Controller’s User Directory, control power and reboot switching and display unit status via SNMP, as described in Section 13.

Both the Text Interface and Web Browser Interface allow the following parameters to be defined:

- **Enable:** Enables/disables SNMP Polling. (Default = Off.)

Note:

This item only applies to external SNMP polling of the Elite Managed Power Controller; it does not effect the ability of the Elite Managed Power Controller to send SNMP traps.

- **Version:** This parameter determines which SNMP Version the Elite Managed Power Controller will respond to. For example, if this item is set to V3, then clients who attempt to contact the unit using SNMPv2 will not be allowed to connect. (Default = V1/V2 Only.)
- **Read Only:** Enables/Disables the “Read Only Mode”, which controls the ability to access configuration functions and invoke switching commands. When Enabled (“Yes”), you will not be able to change configuration parameters or invoke other commands when you contact the Elite Managed Power Controller via SNMP. (Default = No.)

Note:

In order to define user names for the Elite Managed Power Controller via your SNMP client, the Read Only feature must be disabled. When the Read Only feature is enabled, you will not be able to issue configuration commands to the unit via SNMP.

- **Authentication / Privacy:** Configures the Authentication and Privacy features for SNMPv3 communication. The Authentication / Privacy parameter offers two options, which function as follows:
 1. **Auth/noPriv:** An SNMPv3 username and password will be required at log in, but encryption will not be used. (Default Setting.)
 2. **Auth/Priv:** An SNMPv3 username and password will be required at log in, and all messages will be sent using encryption.

Notes:

- **The Authentication / Privacy item is not available when the Version parameter is set to V1/V2.**
- **If the Version Parameter is set to V1/V2/V3 (all) and Authentication / Privacy parameter is set to “Auth/Priv”, then only V3 data will be encrypted.**
- **The Elite Managed Power Controller supports DES encryption, but does not currently support the AES protocol.**
- **The Elite Managed Power Controller does not support “noAuth/noPriv” for SNMPv3 communication.**
- **SNMPv3 User Name:** Sets the User Name for SNMPv3. Note that this option is not available when the Version parameter is set to V1/V2. (Default = undefined.)
- **SNMPv3 Password:** Sets the password for SNMPv3. Note that this option is not available when the Version parameter is set to V1/V2. (Default = undefined.)
- **SNMPv3 Password Confirm:** This prompt is used to confirm the SNMPv3 password that was entered at the prompt above. Note that this option is not available when the Version parameter is set to V1/V2. (Default = undefined.)

- **Authentication Protocol:** This parameter determines which authentication protocol will be used. The Elite Managed Power Controller supports both MD5 and SHA1 authentication. (Default = MD5.)

Notes:

- **The Authentication Protocol that is selected for the Elite Managed Power Controller must match the protocol that your SNMP client will use when querying the Elite Managed Power Controller unit.**
- **The Authentication Protocol option is not available when the Version parameter is set to V1/V2**
- **SNMP Contact:** (Default = undefined.)
- **SNMP Location:** (Default = undefined.)
- **SNMP Community:** Note that this parameter is not available when the SNMP Version is set to V3. (Default = Public.)

5.9.7. SNMP Trap Parameters

These menus are used to select parameters that will be used when SNMP traps are sent. For more information on SNMP Traps, please refer to Section 12. To define or change SNMP Trap parameters, proceed as follows:

- **Text Interface:** Type **/n** and press **[Enter]** to display the Network Parameters Menu (Figure 5-17.) At the Network Parameters Menu, type **26** and press **[Enter]** to display the SNMP Trap Parameters Menu.
- **Web Browser Interface:** Click on the “SNMP Traps” link on the left hand side of the Elite Managed Power Controller Home screen to display the SNMP Trap Parameters Menu.

Both the Text Interface and Web Browser Interface allow the following parameters to be defined:

- **SNMP Manager 1:** The IP Address for the first SNMP Manager. For more information, please refer to Section 12. (Default = Undefined.)

Note:

In order to enable the SNMP Trap feature, you must define at least one SNMP Manager.

- **SNMP Manager 2:** (Default = Undefined.)
- **Trap Community:** (Default = Public.)

5.9.8. LDAP Parameters

The Elite Managed Power Controller supports LDAP (Lightweight Directory Access Protocol,) which allows authentication via the “Active Directory” network Directory Service. When LDAP is enabled and properly configured, command access rights can be granted to new users without the need to define individual new accounts at each Elite Managed Power Controller unit, and existing users can also be removed without the need to delete the account from each unit. This type of authentication also allows administrators to assign users to LDAP groups, and then specify which plugs the members of each group will be allowed to control at each Elite Managed Power Controller unit.

In order to apply the LDAP feature, you must first define User Names and associated Passwords and group membership via your LDAP server, and then access the Elite Managed Power Controller command mode to enable and configure the LDAP settings and define port access rights and command access rights for each group that you have specified at the LDAP server.

To access the LDAP Parameters menu, login to Elite Managed Power Controller command mode using a password that permits Administrator Level commands and then proceed as follows:

- **Text Interface:** Type **/N** and press **[Enter]** to display the Network Parameters Menu (Figure 5-17.) At the Network Parameters Menu, type **27** and press **[Enter]** to display the LDAP Parameters Menu.
- **Web Browser Interface:** Click on the “LDAP Parameters” link on the left hand side of the screen to display the LDAP Parameters Menu.

Notes:

- **Plug access rights are not defined at the LDAP server. They are defined via the LDAP Group configuration menu on each Elite Managed Power Controller unit and are specific to that unit alone.**
- **When LDAP is enabled and properly configured, LDAP authentication will supersede any passwords and access rights that have been defined via the Elite Managed Power Controller user directory.**
- **If no LDAP groups are defined on a given Elite Managed Power Controller unit, then access rights will be determined as specified by the “default” LDAP group.**
- **The “default” LDAP group cannot be deleted.**

The LDAP Parameters Menu allows you to define the following parameters:

- **Enable:** Enables/disables LDAP authentication. (Default = Off.)
- **Primary Host:** Defines the IP address or domain name (up to 64 characters) for the primary LDAP server. (Default = undefined.)
- **Secondary Host:** Defines the IP address or domain name (up to 64 characters) for the secondary (fallback) LDAP server. (Default = undefined.)
- **LDAP Port:** Defines the port that will be used to communicate with the LDAP server. (Default = 389.)
- **TLS/SSL:** Enables/Disables TLS/SSL encryption. Note that when TLS/SSL encryption is enabled, the LDAP Port should be set to 636. (Default = Off.)
- **Bind Type:** Sets the LDAP bind request password type. Note that in the Text Interface, when the Bind Type is set to “Kerberos” LDAP menu will include an additional prompt (item 14) that is used to select Kerberos parameters as described in Section 5.9.8.5. In the Web Interface, the button which is used to access the Kerberos Parameters menu is located at the bottom of the LDAP Parameters Menu.(Default = Simple.)
- **Search Bind DN:** Selects the user name who is allowed to search the LDAP directory. (Default = undefined.)
- **Search Bind Password:** Sets the Password for the user who is allowed to search the LDAP directory. (Default = undefined.)
- **User Search Base DN:** Sets the directory location for user searches. (Default = undefined.)
- **User Search Filter:** Selects the attribute that lists the user name. Note that this attribute should always end with “=%S” (no quotes.) (Default = undefined.)
- **Group Membership Attribute:** Selects the attribute that list group membership(s). (Default = undefined.)
- **Group Membership Value Type:** (Default = DN.)

- **Fallback:** Enables/Disables the LDAP fallback feature. When enabled, the unit will revert to its own internal user directory (see Section 5.5) if no defined users are found via the LDAP server. In this case, port access rights will then be granted as specified in the default LDAP group. (Default = Off.)
- **LDAP Group Setup:** Provides access to a submenu, which is used to define LDAP Groups as described in the Sections 5.9.8.1 through 5.9.8.4.
- **Kerberos Setup:** Provides access to the Kerberos Setup menu as described in Section 5.9.8.5. When the Bind Type parameter is set to “Kerberos”, the Kerberos Setup menu is used to select Kerberos parameters. Note that in the Text Interface, the link to the Kerberos Setup menu will not be displayed unless the Bind Type has been set to Kerberos.

5.9.8.1. Adding LDAP Groups

Once you have defined several users and passwords via your LDAP server, and assigned those users to LDAP Groups, you must then grant command and port access rights to each LDAP Group at each individual Elite Managed Power Controller unit.

To add LDAP groups to your Elite Managed Power Controller unit, log in to the command mode using a password that permits Administrator Level commands, and then proceed as follows:

- **Text Interface:** Type **/N** and press **[Enter]** to display the Network Parameters Menu (Figure 5-17.) At the Network Parameters Menu, type **27** and press **[Enter]** to display the LDAP parameters menu, then type **13** and press **[Enter]** to display the LDAP Group Menu. At the LDAP Group Menu, type **2** and press **[Enter]** to display the Add LDAP Group Menu.
- **Web Browser Interface:** Click on the LDAP Parameters link to display the LDAP Parameters Menu. At the LDAP Parameters Menu, click on the LDAP Group Setup button to display the LDAP Group Setup Menu, then click the Add LDAP Group link to display the Add LDAP Group Menu.

The Add LDAP Group menu allows the following parameters to be defined:

- **Group Name:** Note that this name must match the LDAP Group names that you have assigned to users at your LDAP server. (Default = undefined.)
- **Access Level:** Sets the command access level to either Administrator, SuperUser, User or ViewOnly. For more information on Access Levels, please refer to Section 5.4.1. (Default = User.)

- **Plug Access:** This item is used to determine which plugs members of this group will be allowed to control. (Default = All Plugs Off.)

Notes:

- **Web Browser Interface:** When granting access to plugs on optional AUX units, via the Web Browser interface, select the desired plugs from the “Configure Plug Access” drop down menu.
- **Text Interface:** When granting access to plugs on AUX units via the Text Interface, proceed as follows:
 1. From the Add LDAP Group menu, type 3 and press [Enter] to display the Plug Access menu. At the Plug Access menu, select plugs for your local Elite Managed Power Controller unit as you normally would, and when finished, press [Enter] to return to the Add LDAP Group menu.
 2. To grant access to plugs on AUX units, type 3 and press [Enter] again to return to the Plug Access menu, and then type > (greater than symbol) and press [Enter] to scroll to the desired AUX unit. When the desired AUX unit is displayed, select plugs for the AUX unit, and then press [Enter] to return to the Add LDAP Group Menu.
 3. Repeat Step 2 above to grant access to plugs on additional AUX units.
 4. When you have finished granting Plug Access rights to this LDAP group, make certain to press [Esc] several times until the “Saving Configuration” message is displayed and the unit returns to the command prompt.
- **Plug Group Access:** This item is used to determine which plug groups the members of this LDAP Group will be allowed to control. (Default = undefined.)
- **Service Access:** This item determines how members of this LDAP Group will be allowed to access command mode. The Service Access parameter is used to allow members of this LDAP group to access command mode via Serial Port or Telnet/SSH or any combination thereof. (Default = Serial Port = On, Telnet/SSH = On.)

- **Current Metering:** Determines whether or not members of this LDAP Group will be allowed to view current, voltage and temperature readings from the Elite Managed Power Controller unit.

Note:

After you have finished defining LDAP Group parameters, make certain to save the changes before proceeding. In the Web Browser Interface, click on the “Add LDAP Group” button to save parameters; in the Text Interface, press the [Esc] key several times until the Elite Managed Power Controller displays the “Saving Configuration” message.

5.9.8.2 Viewing LDAP Groups

If you want to examine an existing LDAP group, the “View LDAP Groups” function can be used to review the group’s parameters and Plug Access Settings. To view an existing LDAP group on your Elite Managed Power Controller unit, proceed as follows:

- **Text Interface:** Type **/n** and press **[Enter]** to display the Network Parameters Menu (Figure 5-17.) At the Network Parameters Menu, type **27** and press **[Enter]** to display the LDAP Parameters Menu, then type **13** and press **[Enter]** to display the LDAP Group Menu, then type **1** and press **[Enter]**. The Elite Managed Power Controller will prompt you to select the desired group; key in the name of the group and press **[Enter]**. The View LDAP Group screen will be displayed.
- **Web Browser Interface:** Click on the LDAP Parameters link on the left hand side of the screen to display the LDAP Parameters Menu. At the LDAP Parameters Menu, click on the LDAP Group Setup button to display the LDAP Group Setup Menu, then click the View/Modify LDAP Group link to display the Choose LDAP Group Menu; use the drop down menu to select the desired group, select View LDAP Group and then click the Choose LDAP Group button.

5.9.8.3. Modifying LDAP Groups

If you want to modify an existing LDAP Group in order to change parameters or plug access rights, the “Modify LDAP Group” function can be used to reconfigure group parameters. To Modify an existing LDAP Group, access the Elite Managed Power Controller command mode using a password that permits access to Administrator Level commands, and then proceed as follows:

- **Text Interface:** Type **/N** and press **[Enter]** to display the Network Parameters Menu (Figure 5-17.) At the Network Parameters Menu, type **27** and press **[Enter]** to display the LDAP Parameters Menu, then type **13** and press **[Enter]** to display the LDAP Group Menu, then type **3** and press **[Enter]**. The Elite Managed Power Controller will prompt you to select the desired group; key in the name of the group and press **[Enter]**, the Elite Managed Power Controller will display the Modify LDAP Group screen.
- **Web Browser Interface:** Click on the LDAP Parameters link on the left hand side of the screen to display the LDAP Parameters Menu. At the LDAP Parameters Menu, click on the LDAP Group Setup button to display the LDAP Group Setup menu, then click the View/Modify LDAP Group link to display the Choose LDAP Group menu; use the drop down menu to select the desired group, select Modify LDAP Group and then click the Choose LDAP Group button.

Once you have accessed the Modify LDAP Group menu, use the menu options to redefine parameters in the same manner that is used for the Add LDAP Group menu, as discussed in Section 5.9.8.1.

Note:

After you have finished modifying LDAP Group parameters, make certain to save the changes before proceeding. In the Web Browser Interface, click on the “Modify LDAP Group” button to save parameters; in the Text Interface, press the [Esc] key several times until the Elite Managed Power Controller displays the “Saving Configuration” message and the cursor returns to the command prompt.

5.9.8.4. *Deleting LDAP Groups*

The Delete LDAP Group function is used to delete LDAP Groups that are no longer in use. To delete an existing LDAP Group, proceed as follows:

- **Text Interface:** Type **/n** and press **[Enter]** to display the Network Parameters Menu (Figure 5-17.) At the Network Parameters Menu, type **27** and press **[Enter]** to display the LDAP Parameters Menu, then type **13** and press **[Enter]** to display the LDAP Group Menu, then type **4** and press **[Enter]**. The Elite Managed Power Controller will prompt you to select the desired group; key in the name of the group and press **[Enter]**. The unit will delete the specified LDAP Group immediately, without further prompting.
- **Web Browser Interface:** Click on the LDAP Parameters link on the left hand side of the screen to display the LDAP Parameters Menu. At the LDAP Parameters Menu, click on the LDAP Group Setup button to display the LDAP Group Setup Menu, then click the View/Modify LDAP Group link to display the Choose LDAP Group Menu; use the drop down menu to select the desired group, select Delete LDAP Group and then click the Choose LDAP Group button to display the Delete LDAP Group Menu. If the Delete LDAP Group Menu shows the desired group, then click the Delete LDAP Group button to immediately delete the group.

5.9.8.5. LDAP Kerberos Set Up

Kerberos is a network authentication protocol, which provides a secure means of identity verification for users who are communicating via a non-secure network.

To access the LDAP Kerberos Set Up menu, enter command mode using a password that permits access to Administrator Level commands and then proceed as follows:

- **Text Interface:** Type `/N` and press `[Enter]` to display the Network Parameters Menu (Figure 5-17.) At the Network Parameters Menu, type `27` and press `[Enter]` to display the LDAP Parameters Menu. At the LDAP Parameters Menu, type `5` and press `[Enter]` and then use the resulting submenu to set the Bind Type to Kerberos. Next, return to the LDAP Parameters Menu. Note that the LDAP Parameters Menu now includes a prompt which is used to select Kerberos parameters. Type `14` and press `[Enter]` to display the Kerberos Set Up Menu.
- **Web Browser Interface:** Click on the LDAP Parameters link on the left hand side of the screen to display the LDAP Parameters Menu. At the LDAP Parameters Menu, click on the LDAP Kerberos Setup button to display the LDAP Kerberos Setup menu.

The LDAP Kerberos Setup menu allows you to define the following parameters:

- **Port:** (Default = 88.)
- **Realm:** (Default = Undefined.)
- **Key Distribution Centers (KDC1 through KDC5):** (Default = Undefined.)
- **Domain Realms 1 through 5:** (Default = Undefined.)

5.9.9. TACACS Parameters

To access the TACACS Configuration Menus, proceed as follows:

- **Text Interface:** Type **/N** and press **[Enter]** to access the Network Configuration Menu. From the Network Configuration Menu, type **28** and press **[Enter]** to display the TACACS Configuration Menu.
- **Web Browser Interface:** Click on the “TACACS Parameters” link, located on the left hand side of the screen, to display the TACACS Configuration Menu.

The TACACS Configuration Menus offer the following options:

- **Enable:** Enables/disables the TACACS feature at the Network Port. (Default = Off.)
- **Primary Address:** Defines the IP address or domain name (up to 64 characters) for your primary TACACS server. (Default = undefined.)
- **Secondary Address:** Defines the IP address or domain name (up to 64 characters) for your secondary, fallback TACACS server (if present.) (Default = undefined.)
- **Secret Word:** Defines the shared TACACS Secret Word for both TACACS servers. (Default = undefined.)
- **Fallback Timer:** Determines how long the Elite Managed Power Controller will continue to attempt to contact the primary TACACS Server before falling back to the secondary TACACS Server. (Default = 15 Seconds.)
- **Fallback Local:** Determines whether or not the Elite Managed Power Controller will fallback to its own password/username directory when an authentication attempt fails. When enabled, the Elite Managed Power Controller will first attempt to authenticate the password by checking the TACACS Server; if this fails, the unit will then attempt to authenticate the password by checking its own internal username directory. (Default = Off.)
- **Authentication Port:** The port number for the TACACS function. (Default = 49.)

5.9.10. RADIUS Parameters

To access the RADIUS Configuration Menus, proceed as follows:

- **Text Interface:** Type **/N** and press **[Enter]** to access the Network Configuration Menu. From the Network Configuration Menu, type **29** and press **[Enter]** to display the RADIUS Configuration Menu.
- **Web Browser Interface:** Click on the “RADIUS Parameters” link on the left hand side of the screen to display the RADIUS Configuration Menu.

The RADIUS Configuration Menus offer the following options:

- **Enable:** Enables/disables the RADIUS feature at the Network Port. (Default = Off.)
- **Primary Address:** Defines the IP address or domain name (up to 64 characters long) for your primary RADIUS server. (Default = undefined.)
- **Primary Secret Word:** Defines the RADIUS Secret Word for the primary RADIUS server. (Default = undefined.)
- **Secondary Address:** Defines the IP address or domain name (up to 64 characters long) for your secondary, fallback RADIUS server (if present.) (Default = undefined.)
- **Secondary Secret Word:** Defines the RADIUS Secret Word for the secondary RADIUS server. (Default = undefined.)
- **Fallback Timer:** Determines how long the Elite Managed Power Controller will continue to attempt to contact the primary RADIUS Server before falling back to the secondary RADIUS Server. (Default = 3 Seconds.)

- **Fallback Local:** Determines whether or not the Elite Managed Power Controller will fallback to its own password/username directory when an authentication attempt fails. When enabled, the Elite Managed Power Controller will first attempt to authenticate the password by checking the RADIUS Server; if this fails, the unit will then attempt to authenticate the password by checking its own internal username directory. This parameter offers three options:
 - ◆ Off: Fallback Local is disabled (Default.)
 - ◆ On (All Failures): Fallback Local is enabled, and the unit will fallback to its own internal user directory when it cannot contact the Radius Server, or when a password or username does not match the Radius Server.
 - ◆ On (Transport Failure): Fallback Local is enabled, but the unit will only fallback to its own internal user directory when it cannot contact the Radius Server.
- **Authentication Port:** The Authentication Port number for the RADIUS function. (Default = 1812.)
- **Accounting Port:** The Accounting Port number for the RADIUS function. (Default = 1813.)
- **Debug:** (Text Interface Only) When enabled, the Elite Managed Power Controller will put RADIUS debug information into Syslog. (Default = Off.)

5.9.10.1. Dictionary Support for RADIUS

The RADIUS dictionary file can allow you to define a user and assign command access rights and plug access rights from a central location. The RADIUS dictionary file is included on the CDROM along with this user's guide. To install the dictionary file on your RADIUS server, please refer to the documentation provided with your server; some servers will require the dictionary file to reside in a specific directory location, others will require the dictionary file to be appended to an existing RADIUS dictionary file.

The RADIUS dictionary file provides the following commands:

- **BB-Super** - Sets the command access level for the user. This command provides the following arguments:

0 = ViewOnly
 1 = User
 2 = SuperUser
 3 = Administrator

For example, in order to set command access level to "SuperUser", the command line would be:

BB-Super="2"

- **BB-Plug-Access** - Determines which plug(s) the user will be allowed to access. This command provides an argument that consists of a four character string, with one character for each the Elite Managed Power Controller's switched outlets. The following options are available for each switched plug:

0 = Off (Deny Access)
 1 = On (Allow Access)

For example, to allow access to Plugs 2 and 4, the command line would be:

BB-Plug-Access="0101"

- **BB-Group-Access** - Determines which plug group(s) the user will be allowed to access. The argument for this command includes a character for each, defined plug group, with the first character in the string being used to represent the first plug group defined, and the last character representing the last plug group defined. The following options are available for each plug group:

0 = Off (Deny Access)

1 = On (Allow Access)

For example, to allow access to the first three defined plug groups out of a total of six defined plug groups, the command line would be:

```
BB-Group-Access="111000"
```

Example:

The following command could be used to set the command access level to "User", allow access to Serial Ports 1, 3, 5 and 7 and Plugs 1 and 2, and also allow access to the first two of five defined plug groups:

```
tom Auth-Type:=Local, User-Password=="tom1"  
Login-Service=Telnet,  
Login-TCP-Port=Telnet,  
User-Name="HARRY-tom",  
BB-Super="1",  
BB-Plug-Access="1100",  
BB-Group-Access="11000",
```

5.9.11. Email Message Parameters

The Email Parameters menu is used to define parameters for email messages that the Elite Managed Power Controller can send to notify you when an alarm is triggered. To define email message parameters, access the Command Mode using a password that permits access to Administrator Level commands and then proceed as follows:

- **Text Interface:** Type **/N** and press **[Enter]** to access the Network Configuration Menu. From the Network Configuration Menu, type **32** and press **[Enter]** to display the Email Configuration Menu.
- **Web Browser Interface:** Click on the “Email Messages” link on the left hand side of the screen to display the Email Configuration Menu.

The Email Configuration menu offers the following options:

- **Enable:** Enables/Disables the Email Messaging feature. When disabled, the Elite Managed Power Controller will not be able to send email messages when an alarm is generated. (Default = On.)
- **SMTP Server:** This prompt is used to define the address of your SMTP Email server. (Default = undefined.)
- **Port Number:** Selects the TCP/IP port number that will be used for email connections. (Default = 25.)
- **Domain:** The domain name for your email server. (Default = undefined.)

Note:

In order to use domain names, you must first define Domain Name Server parameters as described in Section 5.9.5.

- **User Name:** The User Name that will be entered when logging into your email server. (Default = undefined.)
- **Password:** The password that will be used when logging into your email server. (Default = undefined.)
- **Auth Type:** The Authentication type; the Elite Managed Power Controller allows you to select None, Plain, Login, or CRAM-MD5 Authentication. (Default = Plain.)
- **From Name:** The name that will appear in the “From” field in email sent by the Elite Managed Power Controller. (Default = undefined.)

- **From Address:** The email address that will appear in the “From” field in email sent by the Elite Managed Power Controller. (Default = undefined.)
- **To Address:** The address(es) that will receive email messages generated by the Elite Managed Power Controller. Note that up to three “To” addresses may be defined, and that when Alarm Configuration parameters are selected as described in Section 7, you may then designate one, two or all three of these addresses as recipients for email messages that are generated by the alarms. (Default = undefined.)
- **Send Test Email:** Sends a test email, using the parameters that are currently defined for the Email configuration menu.

Note:

The “Send Test Email” function is only available via the Text Interface.

5.10. Save User Selected Parameters

It is strongly recommended to save all user-defined parameters to an ASCII file as described in Section 15. This will allow quick recovery in the event of accidental deletion or reconfiguration of port parameters.

When changing configuration parameters via the Text Interface, make certain that the Elite Managed Power Controller has saved the newly defined parameters before exiting from command mode. To save parameters, press the [Esc] key several times until you have exited from all configuration menus and the unit displays the “Saving Configuration” message and the cursor returns to the command prompt. If newly defined configuration parameters are not saved prior to exiting from command mode, then the Elite Managed Power Controller will revert to the previously saved configuration after you exit from command mode.

5.10.1. Restore Configuration

If you make a mistake while configuring the Elite Managed Power Controller unit, and wish to return to the previously saved parameters, the Text Interface's "Reboot System" command (/I) offers the option to reinitialize the unit using previously backed up parameters. This allows you to reset the unit to previously saved parameters, even after you have changed parameters and saved them.

Notes:

- **The Elite Managed Power Controller will automatically backup saved parameters once a day, shortly after Midnight. This configuration backup file will contain only the most recently saved parameters, and will be overwritten by the next night's daily backup.**
- **When the /I command is invoked, a submenu will be displayed which offers several Reboot options. Options 4 and 5 are used to restore the configuration backup file. The dates shown next to options 4 and 5 indicate the date that you last changed and saved unit parameters.**
- **If the daily automatic configuration backup has been triggered since the configuration error was made, and the previously saved configuration has been overwritten by newer, incorrect parameters, then this function will not be able to restore the previously saved (correct) parameters.**

To restore the previously saved configuration, proceed as follows:

1. Access command move via the Text Interface, using a username/password that permits access to Administrator level commands (see Section 5.1.1.)
2. At the command prompt, type **/I** and press **[Enter]**. The unit will display a submenu that offers several different reboot options.
3. At the submenu, you may choose either Item 4 (Reboot & Restore Last Known Working Configuration) or Item 5 (Restore Last Known Working Configuration.) Key in the number for the desired option, and then press **[Enter]**.

Note:

When invoking the /I command to restore configuration parameters, Item 4 is recommended.

4. The Elite Managed Power Controller will reboot and previously saved parameters will be restored.

6. Reboot Options

In addition to performing reboot cycles in response to commands, the Elite Managed Power Controller can also be configured to automatically reboot outlets when an attached device does not respond to a Ping command (Ping-No-Answer Reboot) or according to a user defined schedule (Scheduled Reboot.)

- **Ping-No-Answer Reboot:** When the Ping-No-Answer feature is enabled, the Elite Managed Power Controller will Ping a user selected IP address at regular intervals. If the IP address does not respond to the Ping command, the Elite Managed Power Controller will reboot one or more user selected outlet(s).
- **Scheduled Reboot:** A scheduled reboot is used to initiate a reboot cycle at a user selected time and day of the week. When properly configured and enabled, the Elite Managed Power Controller will reboot one or more outlets on a daily or weekly basis. The Scheduled Reboot feature can also be used to switch outlet(s) Off at a user selected time, and then switch them back On again at a later, user selected time.

This section describes the procedure for configuring and enabling Ping-No-Answer Reboots and Scheduled Reboots.

Note:

When defining parameters via the Text Interface, make certain to press the [Esc] key to completely exit from the configuration menus and save newly defined parameters. When parameters are defined via the Text Interface, newly defined parameters will not be saved until the “Saving Configuration” message is displayed.

6.1. Ping-No-Answer Reboot

A Ping-No-Answer Reboot can be used to reboot one or more outlets when an attached device does not respond to a Ping Command. In addition, the Ping-No-Answer Reboot feature can also be configured to send an email, Syslog Message or SNMP Trap to notify you whenever a Ping-No-Answer Reboot occurs. Please refer to Section 7.6 for instructions on setting up email alarm notification for Ping-No-Answer reboots.

To set up a Ping-No-Answer Reboot, access command mode using a password that permits Administrator level commands and then proceed as follows:

- **Text Interface:** Type **/RB** and press **[Enter]**. The Reboot Options Menu will be displayed. At the Reboot Options menu, type **1** and press **[Enter]** to display the Ping-No-Answer Reboot Directory menu. From the Ping-No-Answer Reboot Directory Menu, you can Add, Modify, View or Delete Ping-No-Answer Reboot operations as described in the Sections that follow.
- **Web Browser Interface:** Click the “Ping-No-Answer Reboot” link on the left hand side of the screen. The Ping-No-Answer Reboot Configuration menu will be displayed. From the Ping-No-Answer Reboot Configuration menu, you can Add, Modify, View or Delete Ping-No-Answer Reboot operations as described in the Sections that follow.

6.1.1. Adding Ping-No-Answer Reboots

To add a Ping-No-Answer Reboot, access command mode using a password that permits Administrator Level commands and then proceed as follows:

- **Text Interface:** Access the Ping-No-Answer Reboot Directory menu as described in Section 6.1, then type **2** and press **[Enter]** to display the Add Ping-No-Answer Reboot Menu.
- **Web Browser Interface:** Access the Ping-No-Answer Reboot Configuration menu as described in Section 6.1, then click on the Add Ping-No-Answer Reboot link to display the Add Ping-No-Answer Reboot Menu.

Up to 54 Ping-No-Answer Reboots can be defined. The Add Ping-No-Answer menu is used to define the following parameters for each new Ping-No-Answer Reboot:

- **IP Address:** The IP address for the device that you wish to Ping. When the device at this address fails to respond to a Ping, the Elite Managed Power Controller will reboot the selected outlets. (Default = undefined.)
- **Ping Interval:** Determines how often the Ping command will be sent to the selected IP Address. The Ping Interval can be any whole number, from 1 to 2,800 minutes. (Default = 15 Minutes.)
- **Interval After Failed Ping:** Determines how often the Ping command will be sent after a previous Ping command receives no response. (Default = 1 Minute.)
- **Ping Delay After Reboot:** Determines how long the Elite Managed Power Controller will wait to send additional Ping commands, after a Ping-No-Answer Reboot has been initiated. Typically, this option is used to allow time for a device to fully “wake up” after a Ping-No-Answer Reboot before attempting to Ping the device again. (Default = 15 Minutes.)
- **Consecutive Failures:** Determines how many consecutive failures of the Ping command must be detected in order to initiate a Ping-No-Answer Reboot. For example, if this value is set to “3”, then after three consecutive Ping failures, a Ping-No-Answer Reboot will be performed. (Default = 3.)
- **Reboot:** Enables/Disables the Ping-No-Answer Reboot function for the specified IP address. When this item is disabled, the Elite Managed Power Controller will not reboot the specified outlet(s) when a Ping-No-Answer is detected. However, the unit will continue to notify you via Email, Syslog Message and/or SNMP Trap, providing that parameters for these functions have been defined as described in Section 5.9 and email notification for the Ping-No-Answer function has been enabled as described in Section 7.6. (Default = No.)

Notes:

- **In order for Email/Text Message Notification to function, you must first define Email/Text Message parameters as described in Section 5.9.11.**
- **In order for Syslog Message Notification to function, you must first define a Syslog Address as described in Section 5.9.2.**
- **In order for SNMP Trap Notification to function, you must first define SNMP parameters as described in Section 5.9.7.**

- **Plug Access:** Determines which outlet(s) will be rebooted when the IP address for this Ping-No-Answer operation does not respond to a Ping command. Note that in the Text Interface, Plug Access is defined via a separate submenu; in the Web Browser Interface, Plug Access is defined via a drop down menu, which may be accessed by clicking on the “plus” sign in the “Configure Plug Access” field. If your installation includes optional AUX units, please refer to Section 6.1.1.1 for additional instructions regarding granting access to plugs on AUX units. (Default = undefined.)
- **Plug Group Access:** Determines which Plug Group(s) the Ping-No-Answer Reboot for this IP Address will be applied to. Note that in the Text Interface, Plug Group Access is defined via a separate submenu; in the Web Browser Interface, Plug Group Access is defined via a drop down menu, which may be accessed by clicking on the “plus” sign. (Default = undefined.)
- **Ping Test:** Sends a test Ping command to the IP Address defined for this Ping-No-Answer Reboot.

Note:

After you have finished defining or editing Ping-No-Answer Reboot parameters, make certain to save the changes before proceeding. In the Web Browser Interface, click on the “Add Ping No Answer” button to save parameters; in the Text Interface, press the [Esc] key several times until the Elite Managed Power Controller displays the “Saving Configuration” message and the cursor returns to the command prompt.

6.1.1.1. Granting Access to Plugs on AUX Units

Web Browser Interface

To grant access to plugs on AUX units, select the desired plugs from the “Configure Plug Access” drop down menu and then click on the “Add Ping No Answer” button.

Text Interface

When Plug Access for a Ping No Answer Reboot is defined via the Text Interface, the following procedure is used to grant access to plugs on optional AUX/Remote units:

1. From the Add Ping-No-Answer menu, type **7** and press **[Enter]** to display the Plug Access menu. At the Plug Access menu, select plugs for your local Elite Managed Power Controller unit as you normally would, and when finished, press **[Enter]** to return to the Add Ping No Answer menu.
2. To grant access to plugs on AUX units, type **7** and press **[Enter]** again to return to the Plug Access menu, and then type **>** (greater than symbol) and press **[Enter]** to scroll to the desired AUX unit. When the desired AUX unit is displayed, select plugs for the AUX unit as you normally would, and then press **[Enter]** to return to the Add Ping No Answer Menu.

Note:

The first line of the Plug Access menu will indicate the name of the AUX or Local Elite Managed Power Controller unit that is currently selected.

3. Repeat Step 2 above to grant access to plugs on additional AUX units.
4. When you have finished granting Plug Access rights to this Ping No Answer Reboot, define any other desired parameters required, and then make certain to press **[Esc]** several times until the “Saving Configuration” message is displayed and the unit returns to the command prompt.

6.1.2. Viewing Ping-No-Answer Reboot Profiles

After you have defined one or more Ping-No-Answer Reboot profiles, you can review the parameters selected for each profile using the View Ping-No-Answer feature. To view the configuration of an existing Ping-No-Answer profile, access command mode using a password that allows Administrator level commands and then proceed as follows:

- **Text Interface:** Access the Ping-No-Answer Reboot Directory menu as described in Section 6.1, then type **1** and press **[Enter]**. The Elite Managed Power Controller will display a menu which shows all defined Ping-No-Answer Profiles, listed by their IP Addresses. Key in the IP Address for the desired profile, and then press **[Enter]** to display the View Ping-No-Answer Profile menu.
- **Web Interface:** Access the Ping-No-Answer Reboot Configuration menu as described in Section 6.1, then click on the View/Modify Ping-No-Answer Reboot link. The Elite Managed Power Controller will display a menu that allows you to select the desired Ping-No-Answer Reboot and directory function. Select the “View Profile” button, and then click on the down arrow, scroll to the desired Ping-No-Answer Reboot Profile, select the profile, and then click “Choose Ping-No-Answer Profile.”

The Elite Managed Power Controller will display a screen which lists all defined parameters for the selected Ping-No-Answer Reboot Profile.

6.1.3. Modifying Ping-No-Answer Reboot Profiles

After you have defined a Ping-No-Answer profile, you can modify the configuration of the profile using the Modify Ping-No-Answer feature. To modify the configuration of an existing Ping-No-Answer profile, access the command mode using a password that allows Administrator level commands and then proceed as follows:

- **Text Interface:** Access the Ping-No-Answer Reboot Directory menu as described in Section 6.1, then type **3** and press **[Enter]**. The Elite Managed Power Controller will display a menu which shows all defined Ping-No-Answer Profiles, listed by their IP Addresses. Key in the IP Address for the desired profile, and then press **[Enter]** to display the Modify Ping-No-Answer Profile menu.
- **Web Interface:** Access the Ping-No-Answer Reboot Configuration menu as described in Section 6.1, then click on the View/Modify Ping-No-Answer Reboot link. The Elite Managed Power Controller will display a menu that allows you to select the desired Ping-No-Answer Reboot and directory function. Select the “Modify Profile” button, and then click on the down arrow, scroll to the desired Ping-No-Answer Reboot Profile, select the profile, and then click “Choose Ping-No-Answer Profile.”

The Elite Managed Power Controller will display a screen which allows you to modify parameters for the selected Ping-No-Answer Reboot Profile. Note that this screen functions identically to the Add Ping-No-Answer Reboot menu, as discussed in Section 6.1.1.

Note:

After you have finished defining or editing Ping-No-Answer Reboot parameters, make certain to save the changes before proceeding. In the Web Browser Interface, click on the “Change Ping No Answer” button to save parameters; in the Text Interface, press the [Esc] key several times until the unit displays the “Saving Configuration” message and the cursor returns to the command prompt.

6.1.4. Deleting Ping-No-Answer Reboot Profiles

After you have defined one or more Ping-No-Answer profiles, you can delete profiles that are no longer needed using the Delete Ping-No-Answer feature. To delete an existing Ping-No-Answer profile, access the command mode using a password that allows Administrator level commands and then proceed as follows:

- **Text Interface:** Access the Ping-No-Answer Reboot Directory menu as described in Section 6.1, then type **4** and press **[Enter]**. The Elite Managed Power Controller will display a menu which shows all defined Ping-No-Answer Profiles, listed by their IP Addresses. Key in the IP Address for the desired profile, and then press **[Enter]** to delete the selected profile. The selected profile will be deleted immediately, with no further prompting.
- **Web Interface:** Access the Ping-No-Answer Reboot Configuration menu as described in Section 6.1, then click on the View/Modify Ping-No-Answer Reboot link. The Elite Managed Power Controller will display a menu that allows you to select the desired Ping-No-Answer profile and directory function. Select the “Delete Profile” button, and then click on the down arrow, scroll to the desired Ping-No-Answer Reboot Profile, select the profile, and then click “Choose Ping-No-Answer Profile.” The unit will display a screen which lists all defined parameters for the selected profile. To confirm deletion, Click on the “Delete Profile” button.

6.2. Scheduled Reboot

The Scheduled Reboot feature can be used to reboot one or more outlets according to a user-defined schedule, or to automatically turn outlets Off and then On according to a user defined schedule.

To configure a Scheduled Reboot, access command mode using a password that permits access to Administrator level commands and then proceed as follows:

- **Text Interface:** Type **/RB** and press **[Enter]**. The Reboot Options Menu will be displayed. At the Reboot Options menu, type **2** and press **[Enter]** to display the Scheduled Reboot Directory menu. From the Scheduled Reboot Directory Menu, you can Add, Modify, View or Delete Scheduled Reboots as described in the Sections that follow.
- **Web Browser Interface:** Click the “Scheduled Reboot” link on the left hand side of the screen. The Scheduled Reboot Configuration menu will be displayed. From the Scheduled Reboot Configuration menu, you can Add, Modify, View or Delete Scheduled Reboots as described in the Sections that follow.

Note:

After you have finished defining or editing Scheduled Reboot parameters, make certain to save the changes before proceeding. In the Web Browser Interface, click on the “Add Scheduled Reboot” button to save parameters; in the Text Interface, press the [Esc] key several times until the unit displays the “Saving Configuration” message and the cursor returns to the command prompt.

6.2.1. Adding Scheduled Reboots

To add a Scheduled Reboot, access command mode using a password that permits Administrator Level commands and then proceed as follows:

- **Text Interface:** Access the Scheduled Reboot Directory menu as described in Section 6.2, then type **2** and press **[Enter]** to display the Add Scheduled Reboot Menu.
- **Web Browser Interface:** Access the Scheduled Reboot Configuration menu as described in Section 6.2, then click on the Add Scheduled Reboot link to display the Add Scheduled Reboot Menu.

The Elite Managed Power Controller allows up to 54 Scheduled Reboots to be defined.

The Add Scheduled Reboot menu allows you to define the following parameters for each new Scheduled Reboot:

- **Scheduled Reboot Name:** Assigns a name to this Scheduled Reboot. (Default = undefined.)
- **Plug Action:** Determines whether the Scheduled Reboot will result in the outlet(s) being switched Off, or cycled Off and then On again (Reboot.) Note that when “Off” is selected, the “Day On” option and the “Time On” option can be used to select a time and day when the outlet(s) will be switched back On again. (Default = Off.)
- **Recurrence:** Determines whether the Scheduled Reboot will be performed on a Daily basis or a Weekly basis. (Default = Daily.)
- **Day:** Determines the day of the week that this Scheduled Reboot will occur on. (Default = undefined.)
- **Time:** Determines the time of the day that this Scheduled Reboot will occur on. (Default = 12:00.)
- **Turn ON Day:** When the “Action” parameter is set to “Off”, this parameter can be used to determine the day that the outlet(s) will be switched back On again. (Default = undefined.)
- **Turn ON Time:** When the “Action” parameter has been set to “Off”, this parameter can be used to determine the time when the outlet(s) will be switched back On again. (Default = 12:01.)
- **Plug Access:** Determines which outlet(s) this Scheduled Reboot action will be applied to. In the Text Interface, outlets are selected by typing **9**, pressing **[Enter]** and then following the instructions in the resulting submenu. In the Web Browser Interface, outlets are designated by clicking on the “plus” sign in the Plug Access field, and then selecting the desired outlets from the drop down menu. If your installation includes optional AUX units, please refer to Section 6.2.1.1 for additional instructions regarding granting user account access to plugs on AUX units. (Default = undefined.)
- **Plug Group Access:** Determines which Plug Group(s) this Scheduled Reboot action will be applied to. Note that in the Text Interface, Plug Group Access is defined via a separate submenu; in the Web Browser Interface, Plug Group Access is defined via a drop down menu, which may be accessed by clicking on the “plus” sign in the Plug Group Access field. (Default = undefined.)

6.2.1.1. Granting Access to Plugs on AUX Units

Web Browser Interface

To grant access to plugs on AUX units, simply select the desired plugs from the “Configure Plug Access” drop down menu and then click on the “Add Scheduled Reboot” button.

Text Interface

When Plug Access for a Scheduled Reboot is defined via the Text Interface, the following procedure is used to grant access to plugs on optional AUX/Remote units:

1. From the Add Scheduled Reboot menu, type **8** and press **[Enter]** to display the Plug Access menu. At the Plug Access menu, select plugs for your local Elite Managed Power Controller unit as you normally would, and when finished, press **[Enter]** to return to the Add Scheduled Reboot menu.
2. To grant access to plugs on AUX units, type **8** and press **[Enter]** again to return to the Plug Access menu, and then type **>** (greater than symbol) and press **[Enter]** to scroll to the desired AUX unit. When the desired AUX unit is displayed, select plugs for the AUX unit as you normally would, and then press **[Enter]** to return to the Add Scheduled Reboot Menu.

Note:

The first line of the Plug Access menu will indicate the name of the AUX or Local Elite Managed Power Controller unit that is currently selected.

3. Repeat Step 2 above to grant access to plugs on additional AUX units.
4. When you have finished granting Plug Access rights to this Scheduled Reboot, define any other desired parameters required, and then make certain to press **[Esc]** several times until the “Saving Configuration” message is displayed and the unit returns to the command prompt.

6.2.2. Viewing Scheduled Reboot Actions

After you have defined one or more Scheduled Reboots, you can review the parameters selected for each Reboot using the View Scheduled Reboot feature. To view the configuration of an existing Scheduled Reboot, access the command mode using a password that allows Administrator level commands and then proceed as follows:

- **Text Interface:** Access the Scheduled Reboot Directory menu as described in Section 6.2, then type **1** and press **[Enter]**. The Elite Managed Power Controller will display a menu which lists all defined Scheduled Reboots. Key in the name of the desired Scheduled Reboot, and then press **[Enter]** to display the View Scheduled Reboot menu.
- **Web Interface:** Access the Scheduled Reboot Configuration menu as described in Section 6.2, then click on the View/Modify Scheduled Reboot link. The Elite Managed Power Controller will display a menu that allows you to select the desired Scheduled Reboot and directory function. Select the “View Scheduled Reboot” button, and then click on the down arrow, scroll to the desired Scheduled Reboot, select the reboot, and then click the “Choose Scheduled Reboot” button.

The Elite Managed Power Controller will display a screen which lists all defined parameters for the selected Scheduled Reboot action.

6.2.3. Modifying Scheduled Reboots

After you have defined a Scheduled Reboot, you can edit the configuration of the Reboot action using the Modify Scheduled Reboot feature. To modify the configuration of an existing Scheduled Reboot action, access command mode using a password that allows Administrator level commands and then proceed as follows:

- **Text Interface:** Access the Scheduled Reboot Directory menu as described in Section 6.2, then type **3** and press **[Enter]**. The Elite Managed Power Controller will display a menu which lists all defined Scheduled Reboot actions. Key in the name of the desired Scheduled Reboot action, and then press **[Enter]** to display the Modify Scheduled Reboot menu.
- **Web Interface:** Access the Scheduled Reboot Configuration menu as described in Section 6.2, then click on the View/Modify Scheduled Reboot link. The unit will display a menu that allows you to select the desired Scheduled Reboot action and directory function. Select the “Modify Scheduled Reboot” button, and then click on the down arrow, scroll to the desired Scheduled Reboot action, select the Scheduled Reboot, and then click the “Choose Scheduled Reboot” button.

The Elite Managed Power Controller will display a screen which allows you to modify parameters for the selected Scheduled Reboot action. Note that this screen functions identically to the Add Scheduled Reboot menu, as discussed in Section 6.2.1.

6.2.4. Deleting Scheduled Reboots

After you have defined one or more Scheduled Reboot actions, you can delete Reboot actions that are no longer needed using the Delete Scheduled Reboot feature. To delete an existing Scheduled Reboot, access the command mode using a password that allows Administrator level commands and then proceed as follows:

- **Text Interface:** Access the Scheduled Reboot Directory menu as described in Section 6.2, then type **4** and press **[Enter]**. The unit will display a menu which lists all defined Scheduled Reboot actions. Key in the name of the desired reboot action, and then press **[Enter]** to delete the selected Scheduled Reboot. The selected Scheduled Reboot action will be deleted immediately, with no further prompting.
- **Web Interface:** Access the Scheduled Reboot Configuration menu as described in Section 6.2, then click on the View/Modify Scheduled Reboot link. The unit will display a menu that allows you to select the desired Scheduled Reboot action and directory function. Select the “Delete Scheduled Reboot” button, and then click on the down arrow, scroll to the desired Scheduled Reboot, select the Reboot, and then click the “Choose Scheduled Reboot” button. The unit will display a screen which lists all defined parameters for the selected Scheduled Reboot. To confirm deletion, Click on the “Delete Scheduled Reboot” button.

7. Alarm Configuration

When properly configured, the Elite Managed Power Controller can meter current, temperature and voltage readings, and log this information for future review. In addition, the unit can also generate alarms when current or temperature readings exceed user-defined trigger levels, when input voltage is lost, when a circuit breaker is open, when communication with the AUX units is disrupted, when a Ping-No-Answer condition is detected, and when the Invalid Access Lockout feature is triggered.

When any of these conditions are detected, the Elite Managed Power Controller can send an “Alarm” to the proper personnel via Email, Syslog Message or SNMP trap. If the user-defined trigger levels for temperature and current load are exceeded, the unit can also automatically shut off power to non-essential devices (“Load Shedding”) in order to decrease current load and/or the amount of heat generated within the rack. After Load Shedding has taken place, the unit can then restore power to the non-essential devices when temperature and/or current load drop to user-defined acceptable levels.

This section describes the procedure for setting up the unit to send alarm messages when any of these critical situations are detected. For instructions regarding configuration of the Log function, please refer to Section 5.3.4.

Notes:

- **In order to send alarm notification via email, email addresses and parameters must first be defined as described in Section 5.9.11. Email alarm notification will then be sent for all alarms that are enabled as described in this Section.**
- **In order to send alarm notification via Syslog Message, a Syslog address must first be defined as described in Section 5.9.2. Once the Syslog address has been defined, Syslog Messages will be sent for every alarm discussed in this Section, providing that the Trigger Enable parameter for the alarm has been set to “On.”**
- **In order to send alarm notification via SNMP Trap, SNMP Trap parameters must first be defined as described in Section 5.9.7. Once SNMP Trap Parameters have been defined, Traps will be sent for every alarm discussed in this Section, providing that the Trigger Enable parameter for the alarm has been set to “On.”**
- **When defining parameters via the Text Interface, make certain to press the [Esc] key to completely exit from the configuration menu and save newly defined parameters. When parameters are defined via the Text Interface, newly defined parameters will not be saved until the “Saving Configuration” message is displayed.**

To configure the Elite Managed Power Controller's Alarm functions, access the command mode using a password that allows Administrator level commands and then proceed as follows:

- **Text Interface:** Type `/AC` and then press **[Enter]** to display the Alarm Configuration Menu.
- **Web Browser Interface:** Click the "Alarm Configuration" link, located on the left hand side of the screen to display the Alarm Configuration Menu.

7.1. The Over Current Alarms

The Over Current Alarms are designed to inform you when current consumption reaches or exceeds user-defined levels. Depending on the specific model, Elite Managed Power Controller units can have up to four Over Current Alarms (two sets of two alarms):

- The Over Current Line (Initial) Alarm
- The Over Current Line (Critical) Alarm
- The Over Current Branch (Initial) Alarm
- The Over Current Branch (Critical) Alarm

Note:

The Over Current Line Alarms are not included in Elite Managed Power Controller units that include two input circuits.

This provides a maximum of two sets of alarms (Line and Branch) with each set including an initial threshold alarm and a critical threshold alarm. The Line alarms generally monitor the load on the input line, and are only available on single input units, whereas the Branch alarms monitor the load on each branch circuit breaker. Note that some Elite Managed Power Controller models may refer to the Branch as a "Bus."

The Initial alarms are used to provide notification when the level of current consumption reaches a point where you might want to investigate it, whereas the Critical alarms can provide notification when the level of current consumption approaches the maximum allowed level. The trigger levels for the Initial alarms are generally set lower than the trigger levels for the Critical alarms.

If the user-defined trigger levels for current load are exceeded, the Elite Managed Power Controller can automatically shut off power to non-essential devices (“Load Shedding”) in order to decrease current load. After Load Shedding has taken place, the unit can also restore power to the non-essential devices when current load drops to user-defined acceptable levels.

Notes:

- **In order for the Elite Managed Power Controller to provide alarm notification via Email, communication parameters must first be defined as described in Section 5.9.11.**
- **In order for the unit to provide alarm notification via Syslog Message, Syslog parameters must first be defined and Syslog Messages must be enabled as described in Section 5.9.2 and Section 11.**
- **In order for the unit to provide alarm notification via SNMP Trap, SNMP parameters must first be defined, and SNMP Traps must be enabled as described in Section 5.9.7 and Section 12.**

To configure the Over Current Alarms, access the command mode using a password that permits Administrator Level commands, and then proceed as follows:

- **Text Interface:** Type **/AC** and then press **[Enter]** to display the Alarm Configuration Menu. From the Alarm Configuration Menu, key in the number for the alarm that you wish to configure and then press **[Enter]**.
- **Web Browser Interface:** Click the “Alarm Configuration” link, located on the left hand side of the screen to display the Alarm Configuration Menu. From the Alarm Configuration Menu, click on the link for the alarm that you wish to configure.

Note that the configuration menus for all four types of Over Current Alarms offer essentially the same set of parameters, but the parameters defined for each alarm are separate and unique. Therefore, parameters defined for a Critical Alarm will not be applied to an Initial Alarm and vice versa.

All four types of Over Current alarms offer the following parameters:

- **Trigger Enable:** Enables/Disables the trigger for this alarm. When Disabled, this alarm will be suppressed. (Default = On.)

Note:

To cancel an alarm without correcting the condition that caused the alarm, simply toggle the Trigger Enable parameter Off and then back On again.

- **Alarm Set Threshold:** The trigger level for this alarm. When current load exceeds the Alarm Set Threshold, the Elite Managed Power Controller can send an alarm (if enabled) and/or begin load shedding (if enabled.) Note that the Alarm Set Threshold can be entered either in Amps, or as a percentage of maximum capacity. For more information on Load shedding, please refer to Section 7.1.1. (Defaults: Initial Alarms = 80%; Critical Alarms = 90%.)
- **Alarm Clear Threshold:** Determines how low the current load must drop in order for the Alarm condition to be cancelled and for load shedding recovery (if enabled) to occur. The Alarm Clear Threshold can also be entered in either Amps or as a percentage of maximum capacity. For more information on Load Shedding Recovery, please refer to Section 7.1.1. (Defaults: Initial Alarms = 70%; Critical Alarms = 80%.)

Note:

In the Text Interface, values for the Alarm Thresholds are set using two separate parameters; one is used to enter the threshold in Amps, and the other is used to enter the threshold as a percentage of capacity. In the Web Browser Interface, you can choose Amps or percentage using the drop down menu to the right of each parameter.

- **Resend Delay:** Determines how long the Elite Managed Power Controller will wait to resend an email message generated by this alarm, when the initial attempt to send the notification was unsuccessful. (Default = 60 Minutes.)
- **Notify Upon Clear:** When this item is enabled, the Elite Managed Power Controller will send additional notification when the situation that caused the alarm has been corrected. For example, when Notify Upon Clear is enabled, the unit will first send notification when it detects that current consumption has exceeded the trigger value, and then send a second notification when it determines that the current consumption has fallen below the trigger value. (Default = On.)

- **Email Message:** Enables/Disables email notification for this alarm. (Default = On.)

Note:

The **Email Message** parameter offers four different options: **On**, **Off**, **On (Copy to All Triggers)** or **Off (Copy to All Triggers)**. If either of the “**Copy to All Triggers**” options is selected, then email notification for all other alarms will be switched **On** or **Off** as indicated by this parameter. For example, if “**Off (Copy to All Triggers)**” is selected, then **Email notification will be disabled for all other alarms too.**

- **Address 1, 2, and 3:** These parameters are used to select which of the three email addresses defined via the “Email Messages” menu (see Section 5.9.11) will receive the email alarm notification messages generated by this alarm. The Address parameters can be used to select one, or any combination of the addresses defined via the Email Messages menu. (Default = All On.)

Note:

If Email addresses have been previously defined, then the text under the parameters will list the current, user selected email addresses.

- **Subject:** This parameter is used to define the text that will appear in the “Subject” field for all email notification messages generated by the alarm. (Defaults:
 - Over Current Line (Initial) = “Alarm: Over Current Line (Initial)”
 - Over Current Line (Critical) = “Alarm: Over Current Line (Critical)”
 - Over Current Branch (Initial) = “Alarm: Over Current Branch (Initial)”
 - Over Current Branch (Critical) = “Alarm: Over Current Branch (Critical)”
- **Load Shedding:** Provides access to a submenu, which is used to configure and enable the Load Shedding feature for the Over Current Alarm. When Load Shedding is enabled and properly configured, the Elite Managed Power Controller will switch specific, user-selected plugs On or Off whenever the current load exceeds the Alarm Set Threshold value. If the Auto Recovery feature is enabled, the unit can also return these user-selected plugs to their prior status, when current load falls below the Alarm Clear Threshold value. For more information on the Load Shedding Feature and Auto Recovery, please refer to Section 7.1.1.

7.1.1. Over Current Alarms - Load Shedding and Auto Recovery

The Load Shedding feature is used to switch specific, user-defined, non-essential plugs On or Off whenever current load exceeds the Alarm Set Threshold value. This allows the Elite Managed Power Controller to automatically shut Off plugs in order to reduce current load when the load approaches user-defined critical levels. When the Auto Recovery feature is enabled, the unit can also automatically “undo” the effects of the Load Shedding feature when current load again falls to a user-defined non-critical level.

Together, these two features allow the unit to shut off power to non-essential devices when current load is too high, and then switch those same non-essential devices back On again when current load falls to an acceptable level.

For all four possible Over Current Alarms, Load Shedding and Auto Recovery are enabled and configured via submenus of the Over Current Alarm configuration screens. To access the Load Shedding and Auto Recovery configuration menus, access the command mode using an account that permits Administrator level commands, and then proceed as follows:

- **Text Interface:** Access the Over Current Alarm configuration menu as described in Section 7.1, and then type **5** and press **[Enter]** to display the Load Shedding Configuration Menu.
- **Web Browser Interface:** Access the Over Current Alarm configuration menu as described in Section 7.1, and then click on the “Load Shedding” link to display the Load Shedding Configuration Menu.

Note that the Load Shedding Configuration Menus for all four Over Current Alarms offer essentially the same set of parameters, but the parameters defined for each alarm are separate and unique. Therefore, parameters defined for Over Current Branch (Initial) Alarm Load Shedding will not be applied to Over Current Branch (Critical) Alarm Load Shedding and vice versa.

The Load Shedding configuration menus for all four Over Current alarms offer the following parameters:

- **Enable:** Enables/Disables Load Shedding for the corresponding alarm. When enabled, the Elite Managed Power Controller will switch the user specified plugs whenever current load exceeds the Alarm Set Threshold value. (Default = Disable.)

- **Plug State:** Determines whether the selected plugs/plug groups will be switched On or Off when Load Shedding is enabled and current load exceeds the user-defined Alarm Set Threshold. For example, if the Plug State is set to “Off”, then the selected plugs/plug groups will be switched Off when the Alarm Set Threshold is exceeded. (Default = Off.)
- **Auto Recovery:** Enables/Disables the Auto Recovery feature. When both Load Shedding and Auto Recovery are enabled, the Elite Managed Power Controller will return plugs to their former On/Off state after current load falls below the Alarm Clear Threshold value. This allows the unit to “undo” the effects of the Load Shedding feature after current load has returned to an acceptable level. (Default = Off.)
- **Plug Access:** Determines which Plug(s) will be switched when the current load exceeds the Alarm Set Threshold and the Load Shedding feature is triggered. For example, if plugs A1, A2 and A3 are selected, then these plugs will be switched On or Off whenever the current load exceeds the Alarm Set Threshold. (Default = undefined.)

Notes:

- **In the Text Interface, Plug Access is configured by typing 4, pressing [Enter] and then selecting the desired Plug(s) from the resulting submenu.**
- **In the Web Browser Interface, Plug Access is configured by clicking on the “plus” symbol in the “Configure Plug Access” field to display the drop down menu, and then selecting the desired Plug(s) from the drop down menu.**
- **If your installation includes optional AUX units, please refer to Section 7.1.1.1 for additional instructions regarding granting user account access to plugs on AUX units.**

- **Plug Group Access:** Determines which Plug Group(s) will be switched when the current exceeds the Alarm Set Threshold and the Load Shedding feature is triggered. For example, if you have defined a Plug Group named “test”, which includes Plugs B3, B4 and B5, and then selected the “test” Plug Group via the Plug Group Access parameter, then all of the plugs in the “test” Plug Group will be switched On or Off whenever the current exceeds the Alarm Set Threshold. (Default = undefined.)

Notes:

- **In the Text Interface, Plug Group Access is configured by typing 5, pressing [Enter] and then selecting the desired Plug Group(s) from the resulting submenu.**
- **In the Web Browser Interface, Plug Group Access is configured by clicking on the “plus” symbol in the “Configure Plug Group Access” field to display the drop down menu, and then selecting the desired Plug Group(s) from the drop down menu.**
- **Plug Groups must first be defined (as described in Section 5.6) before they will be displayed in the Load Shedding menu’s Plug Group Access submenu.**

7.1.1.1. Granting Access to Plugs on AUX Units

Web Browser Interface

To grant access to plugs on AUX units, simply select the desired plugs from the “Configure Plug Access” drop down menu and then click on the “Change Load Shedding” button.

Text Interface

When Plug Access is defined via the Text Interface, the following procedure is used to grant access to plugs on optional AUX/Remote units:

1. From the Load Shedding menu, type **4** and press **[Enter]** to display the Plug Access menu. At the Plug Access menu, select plugs for your local Elite Managed Power Controller unit as you normally would, and when finished, press **[Enter]** to return to the Load Shedding menu.
2. To grant access to plugs on AUX units, type **4** and press **[Enter]** again to return to the Plug Access menu, and then type **>** (greater than symbol) and press **[Enter]** to scroll to the desired AUX Elite Managed Power Controller unit. When the desired AUX unit is displayed, select plugs for the AUX unit as you normally would, and then press **[Enter]** to return to the Load Shedding Menu.

Note:

The first line of the Plug Access menu will indicate the name of the AUX or Local unit that is currently selected.

3. Repeat Step 2 above to grant access to plugs on additional AUX units.
4. When you have finished granting Plug Access rights for this alarm, define any other desired parameters required, and then make certain to press **[Esc]** several times until the “Saving Configuration” message is displayed and the unit returns to the command prompt.

7.2. The Over Temperature Alarms

The Over Temperature Alarms are designed to inform you when the temperature level inside your equipment rack reaches or exceeds certain user-defined levels. There are two separate Over Temperature Alarms; the Initial Threshold alarm and the Critical Threshold Alarm.

Typically, the Initial Threshold alarm is used to notify you when the temperature within your equipment rack reaches a point where you might want to investigate it, whereas the Critical Threshold alarm is used to notify you when the temperature approaches a level that may harm equipment or inhibit performance. The trigger for the Initial Threshold alarm is generally set lower than the Critical Threshold alarm.

If the user-defined trigger levels for temperature are exceeded, the Elite Managed Power Controller can automatically shut off power to non-essential devices (“Load Shedding”) in order to reduce the amount of temperature that is being generated within the rack. In addition, the Load Shedding feature can also be used to switch On additional components, such as fans or cooling systems in order to dissipate the excess heat. After Load Shedding has taken place, the Load Shedding Recovery feature can be used to return plugs to their previous state after the temperature drops to an acceptable level.

Notes:

- **In order for the Elite Managed Power Controller to provide alarm notification via Email, communication parameters must first be defined as described in Section 5.9.11.**
- **In order for the unit to provide alarm notification via Syslog Message, Syslog parameters must first be defined and Syslog Messages must be enabled as described in Section 5.9.2 and Section 11.**
- **In order for the unit to provide alarm notification via SNMP Trap, SNMP parameters must first be defined, and SNMP Traps must be enabled as described in Section 5.9.7 and Section 12.**

To configure the Over Temperature Alarms, access the Elite Managed Power Controller command mode using a password that permits Administrator Level commands, and then proceed as follows:

- **Text Interface:** Type **/AC** and then press **[Enter]** to display the Alarm Configuration Menu. From the Alarm Configuration Menu, either type **3** and press **[Enter]** to access the Over Temperature (Initial Threshold) Alarm, or type **4** and press **[Enter]** to access the Over Temperature (Critical Threshold) Alarm.
- **Web Browser Interface:** Click the “Alarm Configuration” link, located on the left hand side of the screen to display the Alarm Configuration Menu. From the Alarm Configuration Menu, click on either the “Over Temperature (Initial Threshold)” link or the “Over Temperature (Critical Threshold)” link to access the desired menu.

Note that the Initial Threshold menus and Critical Threshold menus offer essentially the same set of parameters, but the parameters defined for each alarm are separate and unique. Therefore, parameters defined for the Critical Threshold Alarm will not be applied to the Initial Threshold Alarm and vice versa.

Both the Over Temperature (Initial Threshold) alarm and the Over Temperature (Critical Threshold) alarm offer the following parameters:

- **Trigger Enable:** Enables/Disables the trigger for this alarm. When Disabled, this alarm will be suppressed. (Default = On.)

Note:

To cancel an alarm without correcting the condition that caused the alarm, simply toggle the Trigger Enable parameter Off and then back On again.

- **Alarm Set Threshold:** The trigger level for this alarm. When temperature exceeds the Alarm Set Threshold, the Elite Managed Power Controller can send an alarm (if enabled) and/or begin Load Shedding (if enabled.) For more information on Load Shedding for the Over Temperature Alarm, please refer to Section 7.2.1. (Initial Threshold: Default = 90°F or 32°C, Critical Threshold: Default = 100°F or 38°C.)

- **Alarm Clear Threshold:** Determines how low the temperature must drop in order for the Alarm condition to be cancelled and for Load Shedding (if enabled) to occur. For more information on Load Shedding for the Over Temperature Alarm, please refer to Section 7.2.1. (Initial Threshold: Default = 80°F or 27°C, Critical Threshold: Default = 90°F or 38°C.)

Note:

The System Parameters menu is used to set the temperature format for the Elite Managed Power Controller unit to either Fahrenheit or Celsius as described in Section 5.3.

- **Resend Delay:** Determines how long the Elite Managed Power Controller will wait to resend an email message generated by this alarm, when the initial attempt to send notification was unsuccessful. (Default = 60 Minutes.)
- **Notify Upon Clear:** When this item is enabled, the Elite Managed Power Controller will send additional notification when the situation that caused the alarm has been corrected. For example, when Notify Upon Clear is enabled, the unit will send initial notification when it detects that the temperature has exceeded the trigger value, and then send a second notification when it determines that the temperature has fallen below the trigger value. (Default = On.)
- **Email Message:** Enables/Disables email notification for this alarm. (Default = On.)

Note:

The Email Message parameter offers four different options: On, Off, On (Copy to All Triggers) or Off (Copy to All Triggers). If either of the “Copy to All Triggers” options is selected, then email notification for all other alarms will be switched On or Off as indicated by this parameter. For example, if “Off (Copy to All Triggers)” is selected, then Email notification will be disabled for all other alarms too.

- **Address 1, 2, and 3:** These parameters are used to select which of the three email addresses, defined via the “Email Messages” menu (see Section 5.9.11,) will receive the email alarm notification messages generated by this alarm. The Address parameters can be used to select one, or any combination of the addresses defined via the Email Messages menu. (Default = All On.)

Note:

If Email addresses have been previously defined, then the text under the parameters will list the user defined email addresses.

- **Subject:** This parameter is used to define the text that will appear in the “Subject” field for all email notification messages generated by this alarm. (Default = “Alarm: Over Temperature (Initial)” or “Alarm: Over Temperature (Critical)”.)
- **Load Shedding:** Provides access to a submenu, which is used to configure and enable the Load Shedding feature for the Over Temperature alarms. When Load Shedding is enabled and properly configured, the unit will switch specific, user-selected plugs On or Off whenever the temperature exceeds the Alarm Set Threshold value. If the Auto Recovery feature is enabled, the unit can also return these user-selected plugs to their prior status, when the temperature falls below the Alarm Clear Threshold value. For more information on the Load Shedding Feature and Auto Recovery, please refer to Section 7.2.1.

7.2.1. Over Temperature Alarms - Load Shedding and Auto Recovery

In the case of the Over Temperature Alarms, the Load Shedding feature is used to switch specific, user-defined plugs On or Off whenever the temperature exceeds the Alarm Set Threshold value. This allows the Elite Managed Power Controller to automatically shut Off non-essential devices in order to reduce the temperature being generated within the rack, or automatically switch On devices such as fans or cooling systems in order to dissipate heat from the rack. When the Auto Recovery feature is enabled, the unit can also automatically “undo” the effects of the Load Shedding feature when the temperature again falls to a user-defined non-critical level.

For both the Initial Threshold and Critical Threshold Over Temperature Alarms, Load Shedding and Auto Recovery are enabled and configured via submenus of the Over Temperature Alarm configuration screens. To access the Load Shedding and Auto Recovery configuration menus, access the command mode using an account that permits Administrator level commands, and then proceed as follows:

- **Text Interface:** Access the Over Temperature Alarm configuration menu as described in Section 7.2, and then type **5** and press [**Enter**] to display the Load Shedding configuration menu.
- **Web Browser Interface:** Access the Over Temperature Alarm configuration menu as described in Section 7.2, and then click on the “Load Shedding” link to display the Load Shedding configuration menu.

Note that the Load Shedding configuration menus for both the Initial Threshold Alarm and Critical Threshold Alarm offer essentially the same set of parameters, but the parameters defined for each alarm are separate and unique. Therefore, parameters defined for the Critical Threshold Load Shedding will not be applied to the Initial Threshold Alarm and vice versa.

The Load Shedding configuration menus for both the Over Temperature (Initial Threshold) alarm and the Over Temperature (Critical Threshold) alarm offer the following parameters:

- **Enable:** Enables/Disables Load Shedding for the corresponding alarm. When enabled, the Elite Managed Power Controller will switch the user specified plugs whenever the temperature exceeds the Alarm Set Threshold value. (Default = Disable.)

- **Plug State:** Determines whether the selected plugs/plug groups will be switched On or Off when Load Shedding is enabled and the temperature exceeds the user-defined Alarm Set Threshold. For example, if the Plug State is set to “Off”, then the selected plugs/plug groups will be switched Off when the Alarm Set Threshold is exceeded. (Default = Off.)
- **Auto Recovery:** Enables/Disables the Auto Recovery feature. When both Load Shedding and Auto Recovery are enabled, the Elite Managed Power Controller will return plugs to their former On/Off state after the temperature falls below the Alarm Clear Threshold value. This allows the unit to “undo” the effects of the Load Shedding feature after the temperature has returned to an acceptable level. (Default = Off.)
- **Plug Access:** Determines which Plug(s) will be switched when the temperature exceeds the Alarm Set Threshold and the Load Shedding feature is triggered. For example, if plugs A1, A2 and A3 are selected, then these plugs will be switched On or Off whenever the temperature exceeds the Alarm Set Threshold. (Default = undefined.)

Notes:

- **In the Text Interface, Plug Access is configured by typing 4, pressing [Enter] and then selecting the desired Plug(s) from the resulting submenu.**
- **In the Web Browser Interface, Plug Access is configured by clicking on the “plus” symbol in the “Configure Plug Access” field to display the drop down menu, and then selecting the desired Plug(s) from the drop down menu.**
- **If your installation includes optional AUX units, please refer to Section 7.2.1.1 for additional instructions regarding granting user account access to plugs on AUX units.**

- **Plug Group Access:** Determines which Plug Group(s) will be switched when the temperature exceeds the Alarm Set Threshold and the Load Shedding feature is triggered. For example, if you have defined a Plug Group named “test”, which includes Plugs B3, B4 and B5, and then select the “test” Plug Group via the Plug Group Access parameter, then all of the plugs in the “test” Plug Group will be switched On or Off whenever the temperature exceeds the Alarm Set Threshold. (Default = undefined.)

Notes:

- **In the Text Interface, Plug Group Access is configured by typing 5, pressing [Enter] and then selecting the desired Plug Group(s) from the resulting submenu.**
- **In the Web Browser Interface, Plug Group Access is configured by clicking on the “plus” symbol in the “Configure Plug Group Access” field to display the drop down menu, and then selecting the desired Plug Group(s) from the drop down menu.**
- **Plug Groups must first be defined (as described in Section 5.6) before they will be displayed in the Load Shedding menu’s Plug Group Access submenu.**

7.2.1.1. Granting Access to Plugs on AUX Units

Web Browser Interface

To grant access to plugs on AUX units, simply select the desired plugs from the “Configure Plug Access” drop down menu and then click on the “Change Load Shedding” button.

Text Interface

When Plug Access is defined via the Text Interface, the following procedure is used to grant access to plugs on optional AUX/Remote units:

1. From the Load Shedding menu, type **4** and press **[Enter]** to display the Plug Access menu. At the Plug Access menu, select plugs for your local Elite Managed Power Controller unit as you normally would, and when finished, press **[Enter]** to return to the Load Shedding menu.
2. To grant access to plugs on AUX units, type **4** and press **[Enter]** again to return to the Plug Access menu, and then type **>** (greater than symbol) and press **[Enter]** to scroll to the desired AUX unit. When the desired AUX unit is displayed, select plugs for the AUX unit as you normally would, and then press **[Enter]** to return to the Load Shedding Menu.

Note:

The first line of the Plug Access menu will indicate the name of the AUX or Local unit that is currently selected.

3. Repeat Step 2 above to grant access to plugs on additional AUX units.
4. When you have finished granting Plug Access rights for this alarm, define any other desired parameters required, and then make certain to press **[Esc]** several times until the “Saving Configuration” message is displayed and the unit returns to the command prompt.

7.3. The Circuit Breaker Open Alarm

The Circuit Breaker Alarm is intended to provide notification in the event that one of the Elite Managed Power Controller's circuit breakers is opened. When a circuit breaker is open, the unit can provide prompt notification via Email, Syslog Message or SNMP Trap.

Notes:

- **In order for the Elite Managed Power Controller to provide alarm notification via Email, communication parameters must first be defined as described in Section 5.9.11.**
- **In order for the unit to provide alarm notification via Syslog Message, Syslog parameters must first be defined and Syslog Messages must be enabled as described in Section 5.9.2 and Section 11.**
- **In order for the unit to provide alarm notification via SNMP Trap, SNMP parameters must first be defined, and SNMP Traps must be enabled as described in Section 5.9.7 and Section 12.**

To configure the Circuit Breaker Alarm, access the command mode using a password that permits Administrator Level commands, and then proceed as follows:

- **Text Interface:** Type **/AC** and then press **[Enter]** to display the Alarm Configuration Menu. From the Alarm Configuration Menu, type **5** and press **[Enter]** to access the configuration menu for the Circuit Breaker Alarm.
- **Web Browser Interface:** Click the "Alarm Configuration" link, located on the left hand side of the screen to display the Alarm Configuration Menu. From the Alarm Configuration Menu, click on the "Circuit Breaker Open" link to access the configuration menu.

The Circuit Breaker Open Alarm Configuration Menu offers the following parameters:

- **Trigger Enable:** Enables/Disables the trigger for this alarm. When Disabled, this alarm will be suppressed. (Default = On.)

Note:

To cancel an alarm without correcting the condition that caused the alarm, simply toggle the Trigger Enable parameter Off and then back On again.

- **Resend Delay:** Determines how long the Elite Managed Power Controller will wait to resend an email message generated by this alarm, when the initial attempt to send the notification was unsuccessful. (Default = 60 Minutes.)
- **Notify Upon Clear:** When this item is enabled, the Elite Managed Power Controller will send additional notification when the situation that caused the alarm has been corrected. For example, when Notify Upon Clear is enabled, the unit can send initial notification when it detects an open circuit breaker, and then send a second notification when it determines that the circuit breaker has been closed. (Default = On.)
- **Email Message:** Enables/Disables email notification for this alarm. (Default = On.)

Note:

The Email Message parameter offers four different options: On, Off, On (Copy to All Triggers) or Off (Copy to All Triggers). If either of the “Copy to All Triggers” options is selected, then email notification for all other alarms will be switched On or Off as indicated by this parameter. For example, if “Off (Copy to All Triggers)” is selected, then Email notification will be disabled for all other alarms too.

- **Address 1, 2, and 3:** These parameters are used to select which of the three email addresses defined via the “Email Messages” menu (see Section 5.9.11) will receive the email alarm notification messages generated by this alarm. The Address parameters can be used to select one, or any combination of the addresses defined via the Email Messages menu. (Default = All On.)

Note:

If Email addresses have been previously defined, then the text under the parameters will list the current, user selected email addresses.

- **Subject:** This parameter is used to define the text that will appear in the “Subject” field for all email notification messages generated by this alarm. (Default = “Alarm: Circuit Breaker Open”)

7.4. The Lost Communication with AUX Units Alarm

The Lost Communication with AUX Units Alarm is intended to provide prompt notification when communication with the optional AUX units is disrupted. When communication with an attached AUX unit is interrupted, the Elite Managed Power Controller can provide notification via Email, Syslog Message or SNMP Trap.

Notes:

- **In order for the Elite Managed Power Controller to provide alarm notification via Email, communication parameters must first be defined as described in Section 5.9.11.**
- **In order for the unit to provide alarm notification via Syslog Message, Syslog parameters must first be defined and Syslog Messages must be enabled as described in Section 5.9.2 and Section 11.**
- **In order for the unit to provide alarm notification via SNMP Trap, SNMP parameters must first be defined, and SNMP Traps must be enabled as described in Section 5.9.7 and Section 12.**

To configure the Lost Communication with AUX Alarm, access the command mode using a password that permits Administrator Level commands, then proceed as follows:

- **Text Interface:** Type `/AC` and then press **[Enter]** to display the Alarm Configuration Menu. From the Alarm Configuration Menu, type `6` and press **[Enter]** to access the configuration menu for the Lost Communication with AUX Units Alarm.
- **Web Browser Interface:** Click the “Alarm Configuration” link, located on the left hand side of the screen to display the Alarm Configuration Menu. From the Alarm Configuration Menu, click on the “Lost Communication with AUX Units” link to access the configuration menu.

The Lost Communication with AUX Units Alarm Configuration Menu offers the following parameters:

- **Trigger Enable:** Enables/Disables the trigger for this alarm. When Disabled, this alarm will be suppressed. (Default = On.)

Note:

To cancel an alarm without correcting the condition that caused the alarm, simply toggle the Trigger Enable parameter Off and then back On again.

- **Resend Delay:** Determines how long the Elite Managed Power Controller will wait to resend an email message generated by this alarm, when the initial attempt to send the notification was unsuccessful. (Default = 60 Minutes.)
- **Notify Upon Clear:** When this item is enabled, the Elite Managed Power Controller will send additional notification when the situation that caused the alarm has been corrected. For example, when Notify Upon Clear is enabled, the unit will send initial notification when it detects lost communication with the AUX unit, and then send a second notification when it determines that communication has been restored.
(Default = On.)
- **Email Message:** Enables/Disables email notification for this alarm.
(Default = On.)

Note:

The Email Message parameter offers four different options: On, Off, On (Copy to All Triggers) or Off (Copy to All Triggers). If either of the “Copy to All Triggers” options is selected, then email notification for all other alarms will be switched On or Off as indicated by this parameter. For example, if “Off (Copy to All Triggers)” is selected, then Email notification will be disabled for all other alarms too.

- **Address 1, 2, and 3:** These parameters are used to select which of the three email addresses defined via the “Email Messages” menu (see Section 5.9.11) will receive the email alarm notification messages generated by this alarm. The Address parameters can be used to select one, or any combination of the addresses defined via the Email Messages menu. (Default = All On.)

Note:

If Email addresses have been previously defined, then the text under the parameters will list the current, user defined email addresses.

- **Subject:** This parameter is used to define the text that will appear in the “Subject” field for all email notification messages generated by this alarm.
(Default = “Alarm: Lost Comm with AUX Unit”)

7.5. The Lost Voltage (Line In) Alarm

The Lost Voltage (Line In) Alarm is intended to provide notification when one of the power supplies connected to the Elite Managed Power Controller unit, is lost or disconnected. When one of the power supplies is lost, the unit can provide notification via Email, Syslog Message or SNMP Trap.

Notes:

- **The Lost Voltage (Line In) alarm will provide notification when one of the two available power supplies is lost or disconnected. This alarm will not function if both power supplies are lost or disconnected.**
- **In order for the Elite Managed Power Controller to provide alarm notification via Email, communication parameters must first be defined as described in Section 5.9.11.**
- **In order for the unit to provide alarm notification via Syslog Message, Syslog parameters must first be defined and Syslog Messages must be enabled as described in Section 5.9.2 and Section 11.**
- **In order for the unit to provide alarm notification via SNMP Trap, SNMP parameters must first be defined, and SNMP Traps must be enabled as described in Section 5.9.7 and Section 12.**

To configure the Lost Voltage (Line In) Alarm, access the command mode using a password that permits Administrator Level commands, and then proceed as follows:

- **Text Interface:** Type **/AC** and then press **[Enter]** to display the Alarm Configuration Menu. From the Alarm Configuration Menu, type **7** and press **[Enter]** to access the configuration menu for the Lost Voltage (Line In) Alarm.
- **Web Browser Interface:** Click the “Alarm Configuration” link, located on the left hand side of the screen to display the Alarm Configuration Menu. From the Alarm Configuration Menu, click on the “Lost Voltage (Line In)” link to access the configuration menu.

The Lost Voltage Alarm Configuration menu offers the following parameters:

- **Trigger Enable:** Enables/Disables the trigger for this alarm. When Disabled, this alarm will be suppressed. (Default = On.)

Note:

To cancel an alarm without correcting the condition that caused the alarm, simply toggle the Trigger Enable parameter Off and then back On again.

- **Resend Delay:** Determines how long the Elite Managed Power Controller will wait to resend an email message generated by this alarm, when the initial attempt to send the notification was unsuccessful. (Default = 60 Minutes.)
- **Notify Upon Clear:** When enabled, the Elite Managed Power Controller will send additional notification when the situation that caused the alarm has been corrected. For example, when Notify Upon Clear is enabled, the unit will send initial notification when it detects that its power supply has been lost or disconnected, and then send a second notification when it determines that power has been restored. (Default = On.)
- **Email Message:** Enables/Disables email notification for this alarm. (Default = On.)

Note:

The Email Message parameter offers four different options: On, Off, On (Copy to All Triggers) or Off (Copy to All Triggers). If either of the “Copy to All Triggers” options is selected, then email notification for all other alarms will be switched On or Off as indicated by this parameter. For example, if “Off (Copy to All Triggers)” is selected, then Email notification will be disabled for all other alarms too.

- **Address 1, 2, and 3:** These parameters are used to select which of the three email addresses defined via the “Email Messages” menu (see Section 5.9.11) will receive the email alarm notification messages generated by this alarm. The Address parameters can be used to select one, or any combination of the addresses defined via the Email Messages menu. (Default = All On.)

Note:

If Email addresses have been previously specified, then the text under the parameters will list the current email addresses.

- **Subject:** This parameter is used to define the text that will appear in the “Subject” field for all email notification messages generated by this alarm. (Default = “Alarm: Lost Voltage (Line In)”)

7.6. The Ping-No-Answer Alarm

The Ping-No-Answer Alarm is intended to provide notification when one of the IP addresses defined via the Ping-No-Answer Reboot feature (as described in Section 6.1) fails to respond to a Ping command. When one of the user-defined IP addresses fails to answer a Ping command, the unit can provide notification via Email, Syslog Message or SNMP Trap.

Notes:

- In order for this alarm to function, IP Addresses for the Ping-No-Answer reboot feature must first be defined as described in Section 6.1.
- When a Ping-No-Answer condition is detected, the Elite Managed Power Controller can still reboot the user-selected outlet(s) as described in Section 6.1, and can also send an email, Syslog Message and/or SNMP trap if properly configured as described in this section.
- In order for the Elite Managed Power Controller to provide Email alarm notification, communication parameters must first be defined as described in Section 5.9.11.
- In order for the unit to provide Syslog Message notification, Syslog parameters must first be defined and Syslog Messages must be enabled as described in Section 5.9.2 and Section 11.
- In order for the unit to provide SNMP Trap notification when this alarm is triggered, SNMP parameters must first be defined, and SNMP Traps must be enabled as described in Section 5.9.7 and Section 12.

To configure the Lost Voltage (Line In) Alarm, access the command mode using a password that permits Administrator Level commands, and then proceed as follows:

- **Text Interface:** Type **/AC** and then press **[Enter]** to display the Alarm Configuration Menu. From the Alarm Configuration Menu, type **8** and press **[Enter]** to access the configuration menu for the Ping-No-Answer Alarm.
- **Web Browser Interface:** Click the “Alarm Configuration” link, located on the left hand side of the screen to display the Alarm Configuration Menu. From the Alarm Configuration Menu, click on the “Ping-No-Answer” link to access the configuration Menu.

The Ping-No-Answer alarm configuration menu offers the following parameters:

- **Trigger Enable:** Enables/Disables the trigger for this alarm. When Disabled, this alarm will be suppressed. (Default = On.)

Note:

To cancel an alarm without correcting the condition that caused the alarm, simply toggle the Trigger Enable parameter to Off and then back On again.

- **Resend Delay:** Determines how long the Elite Managed Power Controller will wait to resend an email message generated by this alarm, when the initial attempt to send the notification was unsuccessful. (Default = 60 Minutes.)
- **Notify Upon Clear:** When enabled, the Elite Managed Power Controller will send additional notification when the situation that caused the alarm has been corrected. For example, when Notify Upon Clear is enabled, the unit will send initial notification when it detects that a Ping command has failed, and then send a second notification when it determines that the IP address is again responding to the Ping command. (Default = On.)
- **Email Message:** Enables/Disables email notification for this alarm. (Default = On.)

Note:

The Email Message parameter offers four different options: On, Off, On (Copy to All Triggers) or Off (Copy to All Triggers). If either of the “Copy to All Triggers” options is selected, then email notification for all other alarms will be switched On or Off as indicated by this parameter. For example, if “Off (Copy to All Triggers)” is selected, then Email notification will be disabled for all other alarms too.

- **Address 1, 2, and 3:** These parameters are used to select which of the three email addresses defined via the “Email Messages” menu (see Section 5.9.11) will receive the email alarm notification messages generated by this alarm. The Address parameters can be used to select one, or any combination of the addresses defined via the Email Messages menu. (Default = All On.)

Note:

If Email addresses have been previously specified, then the text under the parameters will list the currently defined email addresses.

- **Subject:** This parameter is used to define the text that will appear in the “Subject” field for all email notification messages that are generated by this alarm. (Default = “Alarm: Ping-No-Answer”)

7.7. The Invalid Access Lockout Alarm

The Invalid Access Lockout Alarm is intended to provide notification when the Elite Managed Power Controller has locked the Network port due to repeated, invalid attempts to access command mode. Normally, the Invalid Access Lockout feature (discussed in Section 5.3.2) will lock the network port whenever the unit detects that a user-defined number of invalid passwords have been entered at the Network Port. When the Invalid Access Lockout Alarm is properly configured and enabled as described in this section, the unit can also provide notification via Email, Syslog Message or SNMP Trap.

Notes:

- **In order for this alarm to function, Invalid Access Lockout parameters must first be configured and enabled as described in Section 5.3.2.**
- **When an Invalid Access Lockout occurs, the Elite Managed Power Controller can still lock the network port as described in Section 5.3.2, and can also send an email, Syslog Message and/or SNMP trap if properly configured.**
- **If desired, the Elite Managed Power Controller can be configured to count Invalid Access attempts and provide notification when the counter exceeds a user defined trigger level, without actually locking the port in question. To do this, enable the Invalid Access Lockout Alarm as described here, but when you configure Invalid Access Lockout parameters as described in Section 5.3.2, set the Lockout Attempts and Lockout Duration as you would normally, and then set the “Lockout Enable” parameter to “Off.”**
- **In order for the Elite Managed Power Controller to provide Email alarm notification, communication parameters must first be defined as described in Section 5.9.11.**
- **In order for the unit to provide Syslog Message notification, Syslog parameters must first be defined and Syslog Messages must be enabled as described in Section 5.9.2 and Section 11.**
- **In order for the unit to provide SNMP Trap notification when this alarm is triggered, SNMP parameters must first be defined, and SNMP Traps must be enabled as described in Section 5.9.7 and Section 12.**

To configure the Invalid Access Lockout Alarm, access the command mode using a password that permits Administrator Level commands, and then proceed as follows:

- **Text Interface:** Type **/AC** and then press **[Enter]** to display the Alarm Configuration Menu. From the Alarm Configuration Menu, type **9** and press **[Enter]** to access the configuration menu for the Invalid Access Lockout Alarm.
- **Web Browser Interface:** Click the “Alarm Configuration” link, located on the left hand side of the screen to display the Alarm Configuration Menu. From the Alarm Configuration Menu, click on the “Invalid Access Lockout” link to access the configuration menu.

The Invalid Access Lockout alarm configuration menu offers the following parameters:

- **Trigger Enable:** Enables/Disables the trigger for this alarm. When Disabled, this alarm will be suppressed. (Default = On.)

Note:

To cancel an alarm without unlocking the port, simply toggle the Trigger Enable parameter Off and then back On again.

- **Resend Delay:** Determines how long the Elite Managed Power Controller will wait to resend an email message generated by this alarm, when the initial attempt to send the notification was unsuccessful. (Default = 60 Minutes.)
- **Notify Upon Clear:** When this item is enabled, the Elite Managed Power Controller will send additional notification when the situation that caused the alarm has been corrected. For example, when Notify Upon Clear is enabled, the unit will send initial notification when it detects that an Invalid Access Lockout has occurred, and then send a second notification when it determines that the port has been unlocked. (Default = On.)

- **Email Message:** Enables/Disables email notification for this alarm. (Default = On.)

Note:

The **Email Message** parameter offers four different options: **On**, **Off**, **On (Copy to All Triggers)** or **Off (Copy to All Triggers)**. If either of the “Copy to All Triggers” options is selected, then email notification for all other alarms will be switched **On** or **Off** as indicated by this parameter. For example, if “**Off (Copy to All Triggers)**” is selected, then **Email notification will be disabled for all other alarms too.**

- **Address 1, 2, and 3:** These parameters are used to select which of the three email addresses defined via the “Email Messages” menu (see Section 5.9.11) will receive the email alarm notification messages generated by this alarm. The Address parameters can be used to select one, or any combination of the addresses defined via the Email Messages menu. (Default = All On.)

Note:

If Email addresses have been previously specified, then the text under the parameters will list the current, user defined email addresses.

- **Subject:** This parameter is used to define the text that will appear in the “Subject” field for all email notification messages generated by this alarm. (Default = “Alarm: Invalid Access Lockout”)

8. The Status Screens

The Status Screens are used to display information about the switched outlets, Network Port, Plug Groups, Current and Power Metering and the Alarm Log and Audit Log. The Status Screens are available via both the Text Interface and Web Browser Interface.

8.1. The Network Status Screen

The Network Status screen shows activity at the Elite Managed Power Controller's 16 virtual network ports, and lists the TCP Port Number, Active/Free Status and current user name for each virtual network port.

To view the Network Status Screen, access command mode using a password that permits Administrator Level commands and then proceed as follows:

- **Text Interface:** Type `/SN` and press **[Enter]**.
- **Web Browser Interface:** Click on the “Network Status” link on the left hand side of the screen.

The Network Status Screen lists the following items:

- **Port:** The virtual network port for each connection.
- **TCP Port:** The number of the TCP Port for each connection.
- **Status:** This column will read “Free” if no users are currently connected to the corresponding port, or “Active” if a user has currently accessed command mode via this port.
- **User Name:** The user name for the account that has currently accessed command mode via this port. Note that when the Network Status Screen is viewed via the Text Interface, usernames longer than 22 characters will be truncated and the remaining characters will be displayed as two dots (..).

8.2. The Plug Status Screen

The Plug Status screen shows the On/Off status of the Elite Managed Power Controller's switched outlets and lists user-defined Plug Names, Boot/Sequence Delay values, and Default On/Off settings.

Note:

- When the Plug Status Screen is viewed by an account with "Administrator" or "SuperUser" command access, all plugs are listed. When the Plug Status Screen is viewed by an account with "User" or "ViewOnly" command access, then the screen will list only the outlets that are allowed by the account.
- Section 5.7 describes the procedure for configuring the plug parameters that are listed in the Plug Status Screen.
- When the Plug Status Screen is viewed via the Text Interface, only the first 16 plugs will be displayed. If you are viewing the status of a 20 plug unit, press [Enter] to display the additional plugs. Press [Esc] to exit from the Plug Status Screen.

To view the Plug Status Screen, access the command mode and proceed as follows:

- **Text Interface:** Type `/S` and press [Enter].
- **Web Browser Interface:** Click on the "Plug Status" link on the left hand side of the screen.

The Plug Status Screen lists the following parameters for each switched outlet:

- **Plug:** The alphanumeric number of each switched outlet.

Note:

If an asterisk appears next to the plug number in this column, this indicates that the plug is "busy", and still in the process of completing a previous command. This could be a command that was invoked by the current user or another user.

- **Name:** The user-defined name for each switched outlet.
- **Status:** The current On/Off status of each switched outlet. If the Status column includes an asterisk, this means that this outlet is busy completing another command, that was previously invoked, either by you or another user.

- **Boot Seq. Delay:** The user-defined Boot/Sequence Delay for each switched outlet.
- **Default:** The Default On/Off value for each switched outlet.
- **Priority:** The user-defined priority setting for each switched outlet.

8.3. The Plug Group Status Screen

The Plug Group Status screen shows the configuration details and On/Off status for the Elite Managed Power Controller's user-defined Plug Groups.

Notes:

- **When the Plug Group Status Screen is viewed by an account with “Administrator” or “SuperUser” command access, all plugs and plug groups are listed. When the Plug Status Screen is viewed by an account with “User” or “ViewOnly” command access, then the screen will list only the plugs and plug groups that are allowed by that account.**
- **The procedure for defining parameters for individual plugs is described in Section 5.7. The procedure for defining Plug Groups is described in Section 5.6.**
- **In order to display the Plug Group Status screen, you must first define at least one Plug Group as described in Section 5.6.**
- **When the Plug Group Status Screen is viewed via the Text Interface, only the first 16 plugs will be displayed. Press [Enter] to display the additional plugs. Press [Esc] to exit from the Plug Status Screen.**

To view the Plug Group Status Screen, access the command mode and then proceed as follows:

- **Text Interface:** Type `/SG` and press [Enter].
- **Web Browser Interface:** Click on the “Plug Group Status” link on the left hand side of the screen. The Elite Managed Power Controller will display a screen that lists all currently defined Plug Groups. Click the check box(es) next to the Plug Group(s) that you want to review, and then click on the “Get Plug Group Status” button.

The Plug Group Status Screen lists the following parameters for each Plug Group:

- **Group Name:** The user-defined name for each Plug Group.
- **Unit:** This field will read “Local” if the outlet is located on your local Elite Managed Power Controller unit, or “Remote”, if the outlet is located on an optional, remote AUX Elite Managed Power Controller unit.
- **Plug:** The alphanumeric number of each switched outlet in the Plug Group.
- **Plug Name:** (Web Interface Only) The User Defined name for each switched outlet in the Plug Group.
- **Default:** The Default On/Off value for each switched outlet in the Plug Group.
- **Boot Seq. Delay:** The user-defined Boot/Sequence Delay for each switched outlet in the Plug Group.
- **Status:** The On/Off status of each switched outlet in the Plug Group. If the Status column includes an asterisk, this means that this outlet is busy completing another command, that was previously invoked, either by you or another user.

8.4. The Current Metering Log Screen

The Current Metering Log screen is used to display readings for Amps, Watts, Voltage and temperature for the Elite Managed Power Controller unit as well as any optional AUX Elite Managed Power Controller units that may be connected.

To view the Current Metering Log screen, access the command mode and then proceed as follows:

- **Text Interface:** Type **/M** and press **[Enter]**.
- **Web Browser Interface:** Click on the “Current Metering” link on the left hand side of the screen.

The Current Metering Status screen lists the following parameters for your local Elite Managed Power Controller unit, as well as any attached AUX/Remote units:

- **Current A:** The total current consumption, in Amps, for power circuit A.
- **Voltage A:** The total voltage for power circuit A.
- **Power A:** The total power consumption, in Watts, for power circuit A.
- **Current B:** The total current consumption, in Amps, for power circuit B.
- **Voltage B:** The total voltage for power circuit B.
- **Power B:** The total power consumption, in Watts, for power circuit B.
- **Temperature:** The rack temperature(s) currently detected by the Elite Managed Power Controller unit(s).
- **Total Current:** The total current, in Amps, for both power circuits.
- **Total Power:** The total power, in Watts, for both power circuits.
- **Over Temperature:** Lists the values for the Initial Threshold and Critical Threshold for the Over Temperature Alarms. For more information on the Over Temperature Alarms, please refer to Section 7.2.
- **Over Current:** Lists the values for the Initial Threshold and Critical Threshold for the Over Current Alarms. For more information on the Over Current Alarms, please refer to Section 7.1.

8.5. The Current History Screen

The Current History Screen is used to display current, voltage and temperature readings. In the Web Browser Interface, the Current History can be displayed as a graph, downloaded in CSV format, or downloaded in XML format. In the Text Interface, the Current History can be displayed as straight, ASCII data, or can be downloaded in CSV or XML format. To view the Current History Screen, access the command mode and then proceed as follows:

- **Text Interface:** Type `/L` and press **[Enter]** to access the “Display Logs” main menu. From the “Display Logs” menu, type `3` and press **[Enter]** to display the Current Metering Log Menu. From the Current Metering Log Menu, you can display the Current Metering Log in ASCII, CSV or XML format or erase the existing Current Metering Log.
- **Web Browser Interface:** Click on the “Current History” link on the left hand side of the screen to access the Current Metering Log menu. At the Current Metering Log menu, you can display the Current Metering Log as a graph, or download or display the log in ASCII, CSV or XML format.

When the Current History Screen is displayed in ASCII, CSV or XML format, the unit will show Branch Current, Branch Voltage and temperature readings in tabular format. When the Current History Screen is displayed in graph format, via the Web Browser Interface, the unit will display a page with four graphs:

- **Branch Current:** This graph shows current consumption versus time for each available branch, and also shows the Initial Threshold and Critical Threshold values for the Over Current Branch Alarms.
- **Branch Voltage:** This graph shows voltage consumption versus time for each available branch.
- **Line Current:** This graph shows current consumption versus time for each available line, and will also show the Initial Threshold and Critical Threshold values for the Over Current Line Alarms.

Note:

The Line Current History graph and the Over Current Line Alarms are not available on units that include two power inputs.

- **Temperature:** This graph shows unit temperature versus time for the unit, and also shows the Initial Threshold and Critical Threshold values for the Over Temperature Alarms.

When the Current History Screen is displayed in graph format via the Web Browser, the resulting page will also include a drop down menu which can be used to graph current history for either the local Elite Managed Power Controller unit or AUX/Remote units, and another drop down menu which can be used to graph current history on a daily, weekly, monthly or yearly basis, or show “Live” current history, which graphs current consumption during the last ten minutes (approximately.)

To save Current History data, access command mode using an account that permits Administrator level commands, and then proceed as follows:

- **Text Interface:** Type `/L` and press **[Enter]** to show the Display Logs menu. From the Display Logs menu, type `3` and press **[Enter]** to display the Current History menu, which allows you to either display the Current History log in ASCII format, download and save in CSV or XML format, or erase the Current History Log.
- **Web Browser Interface:** Click on the “Current History” link on the left hand side of the screen to display the Current History menu, which offers the choice to display Current History in graph, ASCII, CSV or XML format.
- **ASCII:** To save in ASCII format, click the “Display ASCII” link. The Elite Managed Power Controller will prompt you to select the desired unit; use the drop down menu to select either the local unit or an AUX/Remote unit and then click on the “Get History” link. The Elite Managed Power Controller will display Current History data in ASCII format; to save the data, copy and paste to Windows Notepad or a similar ASCII text editing program and then save the file using the “.txt” filename extension.
- **CSV:** Click the “Display CSV” link. Windows will prompt you to either save Current History data or display it using your default CSV program.
- **XML:** Click the “Display XML” link; the Elite Managed Power Controller will display Current History data in XML format. To save the data, copy and paste to Windows Notepad or a similar ASCII text editing program and then save the file using the “.xml” filename extension.

For more information on Current Metering and Current History, please refer to Section 5.3.4

8.6. The Power Metering Status Screen

The Power Metering Status Screen can be used to display power consumption readings for the Elite Managed Power Controller unit as well as any optional AUX/Remote units that may be connected.

To view the Power Metering Status Screen, access the Elite Managed Power Controller command mode using an account that permits access to Administrator or SuperUser level commands and then proceed as follows:

- **Text Interface:** Type **/L** and press **[Enter]** to access the “Display Logs” menu. From the Display Logs menu, type **4** and press **[Enter]** to display the Power Metering Log menu, then type **1** and press **[Enter]** to access the Power Metering menu. At the Power Metering menu, you can use item **1** to select the Elite Managed Power Controller unit to view and item **2** to select the duration period for the Power Metering status screen. After selecting the unit to view and duration period, type **3** and press **[Enter]** to view the Power Metering Status Screen.
- **Web Browser Interface:** Click on the Power Metering Link on the left hand side of the screen to display the Power Metering menu. At the Power Metering menu, key in the start date and the end date, and then use the drop-down menu to determine whether the Elite Managed Power Controller will display data for only the Local unit, or display total power consumption for both the Local unit and all connected AUX/Remote units. Click on the “Get Chart” button to display the Power Metering Status Screen.

The Elite Managed Power Controller will display a chart that graphs power consumption versus time, and also lists the following:

- **Kilowatt Hours:** The number of Kilowatt Hours that were consumed by each branch during the specified time period.
- **Average Current:** The average current draw for each branch during the specified time period.
- **Average % of Max.:** The average percentage of maximum available current that was used by each branch during the specified time period.
- **Average Power:** The average power consumption for each branch during the specified time period.

8.7. The Power History Screen

The Power History Screen provides a graph that shows power consumption versus time.

To view the Power History Screen, access the command mode using an account that permits Administrator or SuperUser level commands, and then proceed as follows:

Text Interface:

Type **/L** and press **[Enter]** to access the “Display Logs” menu. From the Display Logs menu, type **4** and press **[Enter]** to display the Power Metering Log menu, then type **2** and press **[Enter]** to access the Power History menu.

The Power History menu offers three options:

1. **Display Power History:** Type **1** and press **[Enter]** to access the “Display Power History” menu, which allows you to select the duration period (date) for the Power History screen and then display the resulting data.
2. **Download Power History in CSV Format:** Type **2** and press **[Enter]** to access the “Download Power History CSV” menu, which allows you to select the duration period (date) for the Power History report and then download the resulting data in CSV format.
3. **Download Power History in XML Format:** Type **2** and press **[Enter]** to access the “Download Power History XML” menu, which allows you to select the duration period (date) for the Power History report and then download the resulting data in XML format.

Web Interface:

Click on the “Power History” link on the left hand side of the screen to display the Power History menu. The Power History menu offers the options to display Power History as a graph, or download the Power History in ASCII, CSV or XML format.

To save Power History data, click on the “Power History” link on the left hand side of the screen to display the Power History menu, which offers the choice to display Power History in graph, ASCII, CSV or XML format:

- **ASCII:** To save in ASCII format, click the “Display ASCII” link. The Elite Managed Power Controller will prompt you to select the time resolution for the Power History report; use the drop down menu to select either “Day” or “Month” and then click on the “Get History” link. The unit will display Power History data in ASCII format; to save the data, copy and paste to Windows Notepad or a similar ASCII text editing program and then save the file using the “.txt” filename extension.
- **CSV:** Click the “Display CSV” link. Windows will then prompt you to either save the Power History data or display it using your default CSV program.
- **XML:** Click the “Display XML” link; the Elite Managed Power Controller will display Power History data in XML format. To save the data, copy and paste to Windows Notepad or a similar ASCII text editing program and then save the file using the “.xml” filename extension.

9. Operation

The Elite Managed Power Controller offers two separate command interfaces; the Web Browser Interface and the Text Interface. Both interfaces offer essentially the same command options and features, and in most cases, parameters defined via the Web Browser Interface will also apply when communicating via the Text Interface (and vice versa.)

9.1. Operation via the Web Browser Interface

When using the Web Browser Interface, switching commands are invoked via the Plug Control Screen and Plug Group Control Screen.

9.1.1. The Plug Control Screen - Web Browser Interface

The Plug Control Screen lists the current On/Off status of the Elite Managed Power Controller's Switched Outlets and is used to control switching and rebooting of the outlets.

To invoke On, Off, or Reboot commands, proceed as follows:

1. Access the Elite Managed Power Controller Command Mode as described in Section 5.1.
2. Click on the "Plug Control" link on the left hand side of the screen to display the Plug Control Screen.

Notes:

- **When switching and reboot operations are initiated, Boot/ Sequence Delay times will be applied as described in Section 5.7.**
- **If a switching or reboot command is directed to a plug that is already in the process of being switched or rebooted by a previous command, then the new command will be placed in a queue until the plug is ready to receive additional commands.**
- **If the Status column in the Plug Control Screen includes an asterisk, this means that the corresponding outlet is busy completing a previously invoked command.**
- **When the Plug Control Screen is displayed by an account that permits Administrator or SuperUser level commands, all switched outlets will be displayed.**
- **When the Plug Control Screen is displayed by a User level account, the screen will only include the switched outlets that are allowed by the account.**

3. **Initiating a Reboot Cycle:** From the Plug Control Menu, click the down arrow in the “Action” column for the desired outlet(s), then select “Reboot” from the dropdown menu and click on the “Confirm Plug Actions” button.
4. **Switching Outlets Off:** From the Plug Control Menu, click the down arrow in the “Action” column for the desired outlet(s), then select “Off” from the dropdown menu and click on the “Confirm Plug Actions” button.
5. **Switching Outlets On:** From the Plug Control Menu, click the down arrow in the “Action” column for the desired outlet(s), then select “On” from the dropdown menu and click on the “Confirm Plug Actions” button.
6. **Set Outlets to Default On/Off Status:** From the Plug Control Menu, click the down arrow in the “Action” column for the desired outlet(s), then select “Default” from the dropdown menu and click on the “Confirm Plug Actions” button..

When the “Confirm Plug Actions” button is pressed, the Elite Managed Power Controller will display a screen which lists the selected action(s) and asks for confirmation before proceeding. To implement the selected plug action(s), click on the “Execute Plug Actions” button. The unit will display a screen which indicates that a switching operation is in progress, then display the Plug Status screen when the command is complete. At that time, the Status Screen will list the updated On/Off status of each plug.

9.1.2. The Plug Group Control Screen - Web Browser Interface

The Plug Group Control Screen is used to send switching and reboot commands to the user-defined Plug Groups. As described in Section 5.6, Plug Groups allow you to specify a group of outlets that are dedicated to a similar purpose or client, and then direct switching and reboot commands to the group, rather than switching one plug at a time.

To invoke On, Off, or Reboot commands, proceed as follows:

1. Access the Command Mode as described in Section 5.1.

2. Click on the “Plug Group Control” link on the left hand side of the screen to display the Plug Group Control Screen.

Notes:

- **When switching and reboot operations are initiated, Boot/ Sequence Delay times will be applied as described in Section 5.7.**
 - **If a switching or reboot command is directed to a plug that is already in the process of being switched or rebooted by a previous command, then the new command will be placed in a queue until the plug is ready to receive additional commands.**
 - **When the Plug Group Control Screen is displayed by an account that permits Administrator or SuperUser level commands, all user-defined Plug Groups will be displayed.**
 - **When the Plug Control Screen is displayed by a User level account, the screen will only include the Plug Groups that are specifically allowed for that account.**
3. **Initiating a Reboot Cycle:** From the Plug Group Control screen, locate the Plug Group(s) that you wish to control, then click the down arrow in the task selector box in the “Action” column and use the dropdown menu to select the “Reboot” option. Then click on the “Confirm Plug Group Actions” button to execute the Reboot command.
 4. **Switching Plug Groups Off:** From the Plug Group Control screen, locate the Plug Group(s) that you wish to control, then click the down arrow in the task selector box in the “Action” column and use the dropdown menu to select the “Off” option. Then click on the “Confirm Plug Group Actions” button to switch all plugs in the group Off.
 5. **Switching Plug Groups On:** From the Plug Group Control screen, locate the Plug Group(s) that you wish to control, then click the down arrow in the task selector box in the “Action” column and use the dropdown menu to select the “On” option. Then click on the “Confirm Plug Group Actions” button to switch all plugs in the group On.

- 6. Setting Plug Groups to Default On/Off Status:** From the Plug Group Control screen, locate the Plug Group(s) that you wish to control, then click the down arrow in the task selector box in the “Action” column and use the dropdown menu to select the “Default” option. Then click on the “Confirm Plug Group Actions” button to set all plugs in the selected Plug Group(s) to their user defined default On/Off settings.

When the “Confirm Plug Group Actions” button is pressed, the Elite Managed Power Controller will display a screen which lists the selected plug group(s) and action(s) and asks for confirmation before proceeding. To implement the selected plug group action(s), click on the “Execute Plug Group Actions” button. The unit will display a screen which indicates that a switching operation is in progress, then display the Plug Status screen when the command is complete. At that time, the Status Screen will list the updated On/Off status of each plug.

```

COMMAND MENU:                                     Version 1.52a

DISPLAY                                           CONFIGURATION
/S          Plug Status                          /F          System Parameters
/SG         Plug Group Status                   /P [AUX]    Port Parameters
/SN         Network Status                     /PL [n]     Plug Parameters
/H          Command Menu (Help)                /G          Plug Grouping Parameters
/L          Log                                 /N          Network Configuration
/M          Current Metering                   /RB         Reboot Options
/J [*]     Site ID                             /AC         Alarm Configuration
                                           /I          Reboot System
CONTROL                                           /UF         Upgrade Firmware
<Enter>    Enter Command Mode                 /TEST      Test Network Options
/X          Exit Command Mode
/BOOT <n>  Boot Plug n                         +-----+
/ON <n>    Turn on Plug n                       | n Plug# or name |
/OFF <n>   Turn off Plug n                     | n:n = plug n through plug n |
/DPL      Default all plugs                    | k Key type (1-3) |
/U        Send Parameter File                  | * "all"          |
/K <k>    Send SSH Keys                        | <> Required entry |
/UL      Unlock (Invalid Access)              | [] Optional entry |
                                           | , Link multiple plug commands |
Add ,Y to bypass "Sure?"
EMPC>

```

Figure 9-1: The Help Menu (Administrator Mode; Text Interface)

9.2. Operation via the Text Interface

When using the Text Interface, all switching functions are performed by invoking simple, ASCII commands. ASCII commands are also used to display status screens and to log out of command mode. The Text Interface includes a Help Menu, which summarizes all available commands. To display the Text Interface Help Menu (Figure 9-1), type **/H** and press **[Enter]**.

Note:

When the Help Menu is displayed by a SuperUser, User or ViewOnly level account, the screen will not include commands that are only available to Administrator level accounts.

9.2.1. The Plug Status Screen - Text Interface

When you login to command mode via the Text Interface, the first screen displayed after login is the Plug Status Screen. The Plug Status Screen lists the current status of the Elite Managed Power Controller's Switched AC Outlets and displays the currently defined Site I.D. Message.

Normally, the Plug Status Screen will also be re-displayed each time a command is successfully executed. Note however, that if desired, the Automated Mode (See Section 9.3) can be enabled to suppress the display of the Plug Status Screen after each command.

9.2.2. Switching and Reboot Commands - Text Interface

These commands can be used to switch or reboot the Elite Managed Power Controller's switched plugs, and can also be used to set plugs to the user-defined Power-Up Default values. Plugs may be specified by name or number.

Notes:

- If a switching or reboot command is directed to a plug that is already being switched or rebooted by a previous command, then the new command will be placed in a queue until the plug is ready to receive additional commands.
- If an asterisk appears in the "Status" column for any given plug, this indicates that the plug is currently busy, processing a previously issued command.
- Commands are not case sensitive. All commands are invoked by pressing [Enter].
- When the Plug Control Screen is displayed by an account that permits Administrator level command access, all switched outlets will be displayed.
- When you have accessed command mode using an account that permits Administrator or SuperUser level commands, then switching and reboot commands can be applied to all plugs.
- When you have accessed command mode via a User level account, switching and reboot commands can only be applied to the plugs that are specifically allowed for that account.
- If command confirmation is enabled, the Elite Managed Power Controller will display the Status Screen after commands are successfully completed.
- When switching and reboot operations are initiated, Boot/Sequence Delay times will be applied as described in Section 5.7.
- When used in On/Off/Reboot command lines, plug names and plug group names are not case sensitive.

When switching and reboot commands are executed, the unit will display a “Sure?” prompt, wait for user response, and then complete the command. The unit will pause for a moment while the command is executed, and then return to the Plug Status Screen. To Switch Plugs, or initiate a Reboot Cycle, proceed as follows:

1. Switch Plug(s) On:

- a) **Local Units or Individual Units:** To power-on a plug or Plug Group, type `/ON n` and press **[Enter]**. Where “*n*” is the alphanumeric number or name of the desired plug or Plug Group. For example:

`/ON A1 [Enter]` or `/ON ROUTER [Enter]`

- b) **AUX/Remote Units:** If your local Elite Managed Power Controller unit is connected to one or more optional AUX/Remote units, type `/ON aux n` and press **[Enter]**. Where “*aux*” is the AUX/Remote unit and “*n*” is the alphanumeric number or name of the desired plug. For Example, to switch On Plug A1 on the AUX1 unit, enter the following:

`/ON AUX1 A1 [Enter]`

Note:

Enter a space to separate the AUX parameter from the Plug number.

2. Switch Plug(s) Off:

- a) **Local Units or Individual Units:** To power-off a plug or Plug Group, type `/OFF n` and press **[Enter]**. Where “*n*” is the number or name of the desired plug or Plug Group. Note that the “`/OFF`” command can also be entered as “`/OF`”. For example:

`/OFF B2 [Enter]` or `/OF ROUTER [Enter]`

- b) **AUX/Remote Units:** If your local Elite Managed Power Controller unit is connected to one or more optional AUX/Remote units, type `/OFF aux n` and press **[Enter]**. Where “*aux*” is the AUX/Remote unit and “*n*” is the alphanumeric number or name of the desired plug. Note that the “`/OFF`” command can also be entered as “`/OF`”. For Example, to switch Off Plug A2 on the AUX3 unit, enter either of the following command lines:

`/OFF AUX3 A2 [Enter]` or `/OF AUX3 A2 [Enter]`

Note:

Enter a space to separate the AUX parameter from the Plug number.

3. Reboot Plug(s):

- a) **Local Units or Individual Units:** To initiate a Boot cycle, type `/BOOT n` and press **[Enter]**. Where “*n*” is the alphanumeric number or name of the desired plug or Plug Group. Note that the “`/BOOT`” command can also be entered as “`/BO`”. For example:

`/BOOT B3 [Enter]` or `/BO ATMSWTCH [Enter]`

- b) **AUX/Remote Units:** If your local Elite Managed Power Controller unit is connected to one or more optional AUX/Remote units, type `/BOOT aux n` and press **[Enter]**. Where “*aux*” is the AUX/Remote unit and “*n*” is the number or name of the desired plug. Note that the “`/BOOT`” command can also be entered as “`/BO`”. For Example, to boot Plug A4 on the AUX2 unit, enter either of the following command lines:

`/BOOT AUX2 A4 [Enter]` or `/BO AUX2 A4 [Enter]`

Note:

Enter a space to separate the AUX parameter from the Plug number.

4. **Set All Plugs to Power Up Defaults:** Type `/DPL` and press **[Enter]**. All plugs permitted by your account will be set to their default On/Off status, which is defined via the Plug Parameters Menu as described in Section 5.7.

Notes:

- **When you have accessed command mode using an Administrator or SuperUser level account, the Default command will be applied to all plugs.**
 - **When you have accessed command mode using an account that permits User level command access, the Default command will only be applied to the plugs specifically allowed by that account.**
 - **The `/DPL` command is not available in ViewOnly mode.**
 - **The `/DPL` command will also be applied to any optional AUX/Remote Elite Managed Power Controller units that have been connected to your Local Elite Managed Power Controller unit’s AUX Ports**
5. **Suppress Command Confirmation Prompt:** To execute a Boot/On/Off command without displaying the “Sure?” prompt, include the “*, Y*” option at the end of the command line. For example:

`/ON ROUTER, Y` or `/BOOT B2, Y`

9.2.3. Applying Commands to Several Plugs - Text Interface

As described below, switching and reboot commands can be applied to only one Switched AC Outlet, or to an assortment of outlets. In addition, when optional AUX/Remote units have been connected to the AUX ports, the same command line can also be used to switch outlets on several different AUX units.

Note:

When switching and reboot operations are initiated, Boot/Sequence Delay times will be applied as described in Section 5.7.

1. **Switch Several Plugs:** To apply a command to several plugs, enter the numbers or names for the plugs, separated by a “plus sign” (+) or a comma (,).

Note:

In order for the “+” or “,” operators to work, there must be no spaces between the plug name or number and the plus sign or comma.

- a) **Switch Several Plugs on Local Unit:** When switching more than one plug on your local unit, enter the numbers of the desired plugs, separated by commas or plus signs. For example to switch plugs A1, A3, and A4 on your local unit Off, enter either of the following commands:

```
/OFF A1+A3+A4 [Enter]
```

or

```
/OFF A1 ,A3 ,A4 [Enter]
```

- b) **Switch Several Plugs on AUX/Remote Units:** Use the same command format described above, except pair each plug number with the AUX port where the plug resides. For example, to switch On Plug A1 on the AUX1 unit, Plug A3 on the AUX2 unit and Plug A4 on the AUX3 unit, enter either of the following command lines:

```
/ON AUX1 A1+AUX2 A3+AUX3 A4 [Enter]
```

or

```
/ON AUX1 A1 ,AUX2 A3 ,AUX3 A4 [Enter]
```

Note:

Enter a space to separate the AUX parameter from the Plug number.

- c) **Switch Several Plugs on Both Local and AUX Units:** Use the same command format described above. However, note that in the case of the Local unit, it is not necessary to enter the AUX argument. For example, to switch On Plug A1 on your Local unit, Plug A1 on the AUX1 unit and Plug A1 on the AUX2 unit, enter either of the following command lines:

```
/ON A1+AUX1 A1+AUX2 A1 [Enter]  
or  
/ON A1+AUX1 A1+AUX2 A1 [Enter]
```

Note:

Enter a space to separate the AUX parameter from the Plug number.

2. **Switch a Series of Plugs:** To apply a command to a series of plugs, enter the alphanumeric number for the plugs that mark the beginning and end of the series, separated by a colon (:).
- a) **Switch a Series of Plugs on Local Unit:** When switching a series of plugs on your local Elite Managed Power Controller unit, simply enter the numbers for the plugs that mark the beginning and end of the series, separated by a colon. For example to switch On plugs A1 through A4 on your local unit, enter the following:

```
/ON A1:A4 [Enter]
```

- b) **Switch a Series Plugs on AUX/Remote Units:** If optional AUX/Remote units are connected to your Local unit, use the same command format described above for the Local Unit, except pair each plug number with the AUX port where the plug resides. For example, to switch On plugs A1 through A4 on the AUX 2 unit, enter the following:

```
/ON AUX2 A1:A4 [Enter]
```

Note:

Enter a space to separate the AUX parameter from the Plug numbers.

- c) **Switch a Series of Plugs on Both Local and AUX Units:** Use the same command format described above for AUX units. However, note that in the case of the Local Elite Managed Power Controller unit, it is not necessary to enter the AUX argument. For example, to switch On Plugs A1 through A3 on your Local, and Plugs A2 through A4 on the AUX1 unit, enter either of the following command lines:

```
/ON A1:A3+AUX1 A2:A4 [Enter]
```

or

```
/ON A1:A3,AUX1 A2:A4 [Enter]
```

Note:

Enter a space to separate the AUX parameter from the Plug number.

3. **All Plugs:** To apply a command to all plugs, enter an asterisk in place of the name or number. For example, to Boot all plugs, enter the following:

```
/BO * [Enter]
```

Notes:

- When this command is invoked by a User level account, it will only be applied to the plugs that are specifically allowed for that account.
- If your local Elite Managed Power Controller unit is connected to one or more AUX/Remote units, commands that include the asterisk character will also be applied to all permitted plugs on the AUX/Remote units.

9.2.4. Connecting to Serial Ports - Text Interface

In addition to their default functions, the Console Port, Remote Port and AUX ports can also be used for connection to serial console ports on rack mounted devices, providing convenient back door access. Normally, the AUX ports are used for connection to additional, remote Elite Managed Power Controller units, and the Console port is used for connection to a local control device.

However, if the Remote and AUX ports have been reconfigured as described in Section 5.8.2, then Administrators, SuperUsers and Users will be able to connect to these ports by accessing command mode via the Text Interface and invoking the /C command.

Notes:

- **In order to connect to the Remote or AUX ports, you must first configure these ports as serial ports as described in Section 5.8.2.**
- **User level accounts will only be able to connect to the ports that are specifically permitted by the account as described in Section 5.5.**
- **Administrator accounts, SuperUser accounts and properly configured User accounts will always be allowed to connect to the serial Console port.**

To create a connection to a serial port, first make certain that the port is configured for serial mode, then use an Administrator account, SuperUser account or properly configured User account to access the Text Interface via the Network Port, and proceed as follows:

1. **Console Port Connection:** To connect to the Console port, type /C 1 and press [Enter].
2. **Remote Port Connection:** To connect to the Remote port, type /C REMOTE and press [Enter].
3. **AUX Port Connection:** To connect to one of the three AUX ports, proceed as follows:
 - a) AUX1 Port: Type /C AUX1 and press [Enter].
 - b) AUX2 Port: Type /C AUX2 and press [Enter].
 - c) AUX3 Port: Type /C AUX3 and press [Enter].

To terminate a serial port connection, type ^X ([Ctrl] plus [X]) or issue the currently defined disconnect sequence.

9.3. The Automated Mode

The Automated Mode allows the Elite Managed Power Controller to execute switching and reboot commands, without displaying menus or generating response messages. Automated Mode is designed to allow the unit to be controlled by a device which can generate commands to control power switching functions without human intervention.

When Automated Mode is enabled, the /ON, /OFF, /BOOT, /DPL and /X commands are executed without a “Sure?” confirmation prompt and without command response messages; the only reply to these commands is the “EMPC>” prompt, which is displayed when the command is complete.

Note that although Automated Mode can be enabled using either the Web Browser Interface or Text Interface, Automated Mode is designed primarily for users who wish to send ASCII commands to the Elite Managed Power Controller without operator intervention, and therefore does not specifically apply to the Web Browser Interface. When Automated Mode is enabled, the Web Browser Interface can still be used to invoke On / Off / Boot commands.

Notes:

- **When Automated Mode is enabled, all Elite Managed Power Controller password security functions are disabled, and users are able to access System Level command functions (including the configuration menus) and control plugs without entering a password.**
- **If you need to enable the Automated Mode, but want to restrict network access to configuration menus, it is recommended to enable and configure the IP Security Function as described in Section 5.9.3.**

To enable/disable Automated Mode, access the System Parameters menu (see Section 5.3.) then set the “Automated Mode” option to “On”. When Automated Mode is enabled, Elite Managed Power Controller functions will change as follows:

1. **All Password Security Suppressed:** When a user attempts to access command mode, the password prompt will not be displayed at either the Console Port or the Network Port. Unless specifically restricted by the IP Security Function, all users will be allowed to access both switching and configuration functions, and all commands will be immediately accepted without the requirement to enter a password.

2. **Status Screen Suppressed:** The status screens will not be automatically displayed after commands are successfully executed. Note however, that the /S command can still be invoked to display the status screen as needed.
3. **“Sure?” Prompt Suppressed:** All commands are executed without prompting for user confirmation.
4. **Error Messages Suppressed:** If the [Enter] key is pressed without entering a command, the unit will not respond with the “Invalid Command” message. Note however, that an error message will still be generated if commands are invoked using invalid formats or arguments.

All other status display and configuration commands will still function as normal.

9.4. Manual Operation

In addition to the command driven functions available via the Web Browser Interface and Text Interface, some Elite Managed Power Controller functions can also be controlled manually. For a summary of front panel control functions, please refer to Section 3.1, Section 3.3 and Section 3.4.

9.5. Logging Out of Command Mode

When you have finished communicating with the Elite Managed Power Controller, it is important to always disconnect using either the “LogOut” link (Web Browser Interface) or the /X command (Text Interface), rather than by simply closing your browser window or communications program. When communicating via a PDA, use the PDA’s “Close” function to disconnect and logout.

When you disconnect using the LogOut link or /X command, this ensures that the Elite Managed Power Controller has completely exited from command mode, and is not waiting for the inactivity timeout period to elapse before allowing additional connections.

10. SSH Encryption

In addition to standard Telnet protocol, the Elite Managed Power Controller also supports SSH connections, which provide secure, encrypted access via network. In order to communicate with the unit using SSH protocol, your network node must include an appropriate SSH client.

Note that when the `/K` (Send SSH Key) command is invoked, the Elite Managed Power Controller can also provide you with a public SSH key, which can be used to streamline connection to the unit when using SSH protocol.

Although you can establish an SSH connection to the unit without the public key, the public key provides validation for the Elite Managed Power Controller, and once this key is supplied to the SSH client, the client will no longer display a warning indicating that the unit is not a recognized user when the client attempts to establish a connection.

The `/K` command uses the following format:

```
/K <k> [Enter]
```

Where `k` is an argument that determines which type of public key will be displayed, and the `k` argument offers the following options:

1. SSH1
2. SSH2 RSA
3. SSH2 DSA

For example, to obtain the public SSH key for an SSH2 RSA client, type `/K 2` and then press `[Enter]`.

Note:

Although the Elite Managed Power Controller does not support SSH1, the `/K 1` command will still return a key for SSH1.

11. Syslog Messages

The Syslog feature can create log records of each Alarm Event. As these event records are created, they are sent to a Syslog Daemon, located at an IP address defined via the Network Parameters menu.

11.1. Configuration

If you wish to employ this feature, you must set the real-time clock and calendar via the System Parameters Menu, and define the IP address for the Syslog Daemon via the Network Port Configuration menu.

To configure the Syslog function, please proceed as follows:

1. **Access Command Mode:** Note that the following configuration menus are only available to accounts that permit Administrator level commands.
2. **System Parameters Menu:** Access the System Parameters Menu as described in Section 5.3, then set the following parameters:
 - a) **Set Clock and Calendar:** Set the Real Time Clock and Calendar and/or configure and enable the NTP server feature.
3. **Network Parameters Menu:** Access the Network Parameters Menu as described in Section 5.9, then set the following parameters:
 - a) **Syslog IP Address:** Determine the IP address for the device that will run the Syslog Daemon, then use the Network Port Configuration menu to define the IP Address for the Syslog Daemon.
4. **Syslog Daemon:** In order to capture messages sent by the Elite Managed Power Controller, a computer must be running a Syslog Daemon (set to UDP Port 514) at the IP address specified in Step 3 above.

Once the Syslog Address is defined, Syslog messages will be generated whenever one of the alarms discussed in Section 7 is triggered.

```
TEST NETWORK OPTIONS:

1. SNMP Trap Test Manager 1
2. SNMP Trap Test Manager 2
3. Syslog Test
4. Ping

Enter: #<CR> to select,
      <ESC> to exit ...
```

Figure 11-1: The Test Menu (Text Interface, Administrator Mode Only)

11.2. Testing Syslog Configuration

After you have configured the Elite Managed Power Controller as described in Section 11.1, the /TEST command can be used to make certain that the unit is properly set up. To test the Syslog function, access the command mode via the Text Interface using an account that permits Administrator level commands, then type /TEST and press [Enter] to display the Test Menu shown in Figure 11-1.

When the Syslog Test feature is selected, the unit will attempt to send a test Syslog message, using the current Syslog configuration. If the test message is not received by your Syslog Daemon, review the procedure outlined in Section 11.1 to make certain the Elite Managed Power Controller and the Syslog Daemon are properly configured.

In addition to providing a means to test the Syslog and SNMP Trap features, the Test Menu also includes a Ping command option, which can be used in a manner similar to the DOS ping command to check to make certain that the unit is communicating properly. Note that in order for the Ping command to function with domain names, you must first configure Domain Name Server parameters as described in Section 5.9.5.

12. SNMP Traps

SNMP is an acronym for “Simple Network Management Protocol”. The SNMP Trap function allows the Elite Managed Power Controller to send Alarm Notification messages to two different SNMP managers, each time one of the Alarms discussed in Section 7 is triggered.

Note:

- **The SNMP feature cannot be configured via the SNMP Manager.**
- **SNMP reading ability is limited to the System Group.**
- **The SNMP feature includes the ability to be polled by an SNMP Manager.**
- **Once SNMP Trap Parameters have been defined, SNMP Traps will be sent each time an Alarm is triggered. For more information on Alarm Configuration, please refer to Section 7.**

12.1. Configuration:

To configure the SNMP Trap function, proceed as follows:

1. Access command mode using an account that permits Administrator level commands.
2. **SNMP Trap Parameters:** Access the SNMP Trap Parameters Menu as described in Section 5.9.7. Set the following:
 - a) **SNMP Managers 1 and 2:** The address(es) that will receive SNMP Traps that are generated by one of the Alarms discussed in Section 7. Consult your network administrator to determine the IP address(es) for the SNMP Manager(s), then use the Network Parameters menu to set the IP address for each SNMP Manager. Note that it is not necessary to define both SNMP Managers.

Note:

To enable the SNMP Trap feature, you must define at least one SNMP Manager. SNMP Traps are automatically enabled when at least one SNMP Manager has been defined.

- b) **Trap Community:** Consult your network administrator, and then use the Network Parameters menus to set the Trap Community.

Once SNMP Trap Parameters have been defined, the Elite Managed Power Controller will send an SNMP Trap each time an alarm is triggered.

12.2. Testing the SNMP Trap Function

After you have finished setting up the SNMP Trap function, it is recommended to test the configuration to ensure that it is working correctly. To test configuration of the SNMP Trap function, proceed as follows:

1. Configure the SNMP Trap function as described in Section 12.1.
2. Access the Text Interface command mode using an account that permits Administrator level commands, then invoke the “/TEST” command at the Elite Managed Power Controller command prompt. Note that the /TEST Command is only available in Administrator Mode.
3. Select Item 1 or 2 to send an SNMP test trap to Manager 1 or 2, respectively. It is possible that the ARP table will not be properly setup. If this occurs a message to that effect is displayed and the Elite Managed Power Controller immediately refreshes the ARP table. Repeat steps 2 and 3 to try again.

For more information on the /TEST command and the Test Menu, please refer to Section 11.2.

13. Operation via SNMP

If SNMP Access Parameters have been defined as described in Section 5.9.6, then you will be able to manage user accounts, control power and reboot switching and display unit status via SNMP. This section describes SNMP communication with the Elite Managed Power Controller unit, and lists some common commands that can be employed to manage users, control switching and reboot actions and display unit status.

13.1. Elite Managed Power Controller SNMP Agent

The Elite Managed Power Controller's SNMP Agent supports various configuration, control, status and event notification capabilities. Managed objects are described in the EMPC-MIB.txt document, which can be found on the CDROM included with the Elite Managed Power Controller unit and can be compiled for use with your SNMP client.

13.2. SNMPv3 Authentication and Encryption

The major limitations of SNMPv2 were the failure to include proper username/password login credentials (v2 only used a password type of login, i.e., community name) and the exclusion of encryption for data moving over the internet. SNMPv3 addresses both of these shortcomings.

For SNMPv3, the Elite Managed Power Controller supports two forms of Authentication/Privacy: Auth/noPriv which requires a username/password, but does not encrypt data going over the internet and Auth/Priv which requires a username/password AND encrypts the data going over the internet using DES (AES is not supported at this time). For the Password protocol, the Elite Managed Power Controller supports either MD5 or SHA1.

13.3. Configuration via SNMP

Elite Managed Power Controller User accounts can be viewed, created, modified, and deleted via SNMP. User accounts are arranged in a table of 128 rows, and indexed 1-128. User account parameters, as seen through the SNMP, are summarized below.

- **userTable::userName** – 32 character username
- **userTable::userPassword** – 16 character password
- **userTable::userAccessLevel** – Account access level.
 - 0 – View Access
 - 1 – User Access
 - 2 – Superuser Access
 - 3 – Administrator Access
- **userTable::userLocalAccess** – A string of 20 characters, with one character for each of the 20 possible plugs on the LOCAL Elite Managed Power Controller unit. A ‘0’ indicates that the account does not have access to the plug, and a ‘1’ indicates that the user does have access to the plug.
- **userTable::userAux1Access** – A string of 20 characters, with one character for each of the 20 possible plugs on the AUX1 Elite Managed Power Controller unit. A ‘0’ indicates that the account does not have access to the plug, and a ‘1’ indicates that the user does have access to the plug.
- **userTable::userAux2Access** – A string of 20 characters, with one character for each of the 20 possible plugs on the AUX2 Elite Managed Power Controller unit. A ‘0’ indicates that the account does not have access to the plug, and a ‘1’ indicates that the user does have access to the plug.
- **userTable::userAux3Access** – A string of 20 characters, with one character for each of the 20 possible plugs on the AUX3 Elite Managed Power Controller unit. A ‘0’ indicates that the account does not have access to the plug, and a ‘1’ indicates that the user does have access to the plug.
- **userTable::userGroupAccess** – A string of 54 characters, with one character for each of the 54 possible plug groups in the system. A ‘0’ indicates that the account does not have access to the plug group, and a ‘1’ indicates that the user does have access to the plug group.
- **userTable::userSerialAccess** – Access to the serial interface
 - 0 – No access
 - 1 – Access

- **userTable::userTelnetSshAccess** – Access to the Telnet/SSH interface
 - 0 – No access
 - 1 – Access
- **userTable::userWebAccess** – Access to the Web interface
 - 0 – No access
 - 1 – Access
- **userTable::userCurrentMetering** – Access to the systems current/power metering
 - 0 – No access
 - 1 – Access
- **userTable::userCallbackNum** – 32 character callback number for account
- **userTable::userSubmit** – Set to 1 to submit changes.

13.3.1. Viewing Users

To view users, issue a GET request on any of the user parameters for the index corresponding to the desired user.

13.3.2. Adding Users

For an empty index, issue a SET request on the desired parameters. Minimum requirement is a username and password to create a user, all other parameters will be set to defaults if not specified. To create the user, issue a SET request on the userSubmit object.

13.3.3. Modifying Users

For the index corresponding to the user you wish to modify, issue a SET request on the desired parameters to be modified. Once complete, issue a SET request on the userSubmit object.

13.3.4. Deleting Users

For the index corresponding to the user you wish to delete, issue a SET request on the username with a blank string. Once complete, issue a SET request on the userSubmit object.

13.4. Plug Control via SNMP

13.4.1. Controlling Plugs

ON, OFF, BOOT, and DEFAULT commands can be issued for plugs via SNMP. Plugs are arranged in a table of N rows, where N is the number of plugs in the system. Plug parameters are described below.

- **plugTable::plugID** – String indicating the plugs ID
- **plugTable::plugStatus** – Current state of the plug
 - 0 – Plug is OFF
 - 1 – Plug is ON
- **plugTable::plugAction** – Action to be taken on plug
 - 1 – Mark to turn ON (does not execute)
 - 2 – Mark to turn OFF (does not execute)
 - 3 – Mark to BOOT (does not execute)
 - 4 – Mark to DEFAULT (does not execute)
 - 5 – Mark to turn ON and execute plug actions
 - 6 – Mark to turn OFF and execute plug actions
 - 7 – Mark to BOOT and execute plug actions
 - 8 – Mark to DEFAULT and execute plug actions

Set **plugTable::plugAction** to desired action, as specified by values 1-4 above, for each plug index the action is to be applied to. For the last plug you wish to set before executing the commands, use values 5-8 instead, which will invoke the requested commands all at once.

13.4.2. Controlling Plug Groups

ON, OFF, BOOT, and DEFAULT commands can be issued for plug groups via SNMP. Plug groups are arranged in a table of 54 rows, one row for each plug group in the system. Plug Group parameters are described below.

- **plugGroupTable::plugGroupName** – String indicating the plug groups name
- **plugGroupTable::plugGroupAction** – Action to be taken on plug group
 - 1 – Mark to turn ON (does not execute)
 - 2 – Mark to turn OFF (does not execute)
 - 3 – Mark to BOOT (does not execute)
 - 4 – Mark to DEFAULT (does not execute)
 - 5 – Mark to turn ON and execute plug group actions
 - 6 – Mark to turn OFF and execute plug group actions
 - 7 – Mark to BOOT and execute plug group actions
 - 8 – Mark to DEFAULT and execute plug group actions

Set **plugGroupTable::plugGroupAction** to desired action, as specified by values 1-4 above, for each plug group index the action is to be applied to. For the last plug group you wish to set before executing the commands, use values 5-8 instead, which will invoke the requested commands all at once.

13.5. Viewing Elite Managed Power Controller Status via SNMP

Status of various components of the Elite Managed Power Controller can be retrieved via SNMP. Plug Status, and Environmental Status are currently supported.

13.5.1. Plug Status

The status of each plug in the system can be retrieved using the command below.

- **plugTable::plugStatus** – The status of the plug.
 - 0 – Plug is OFF
 - 1 – Plug is ON

13.5.2. Unit Environment Status

The environment status can be retrieved for various variables for all of the Elite Managed Power Controller units in the system. The environmentUnitTable contains four rows, one row for each unit in the system (LOCAL, AUX1, AUX2, AUX3.)

- **environmentUnitTable::environmentUnitName** – The unit (LOCAL, AUX1, AUX2, or AUX3.)
- **environmentUnitTable::environmentUnitTemperature** – The temperature of the given unit.
- **environmentUnitTable::environmentUnitCurrentA** – Unit's total current for Branch A. Note that Current will be reported in tenths of an Amp (divide result by ten to determine value in Amps.)
- **environmentUnitTable::environmentUnitVoltageA** – Unit voltage for Branch A
- **environmentUnitTable::environmentUnitPowerA** – Power drawn by Branch A
- **environmentUnitTable::environmentUnitCurrentB** – Unit's total current for Branch B. Note that Current will be reported in tenths of an Amp (divide result by ten to determine value in Amps.)
- **environmentUnitTable::environmentUnitVoltageB** – Unit voltage for Branch B
- **environmentUnitTable::environmentUnitPowerB** – Power drawn on Branch B

13.5.3. System Environment Status

The system environment status for the local Elite Managed Power Controller unit and all connected AUX units can be retrieved for the entire system.

- **environmentBranchATotalCurrent** – Total Branch A current for Elite Managed Power Controller system (LOCAL and AUX units.) Note that Total Current will be reported in tenths of an Amp (divide result by ten to determine value in Amps.)
- **environmentBranchATotalPower** – Total Branch A power for Elite Managed Power Controller system (LOCAL and AUX units)
- **environmentBranchBTotatCurrent** – Total Branch B current for Elite Managed Power Controller system (LOCAL and AUX units.) Note that Total Current will be reported in tenths of an Amp (divide result by ten to determine value in Amps.)
- **environmentBranchBTotatPower** – Total Branch B power for Elite Managed Power Controller system (LOCAL and AUX units)
- **environmentSystemTotalCurrent** - Total current drawn by Branch A plus Branch B. Note that Total Current will be reported in tenths of an Amp (divide result by ten to determine value in Amps.)
- **environmentSystemTotalPower** - Total power drawn by Branch A plus Branch B.
- **environmentMonthlyPowerLog** - The monthly power usage log.

13.6. Sending Traps via SNMP

Traps that report various unit conditions can be sent to an SNMP Management Station from the Elite Managed Power Controller. The following traps are currently supported.

- **WarmStart** Trap – Trap indicating a warm start
- **ColdStart** Trap – Trap indicating a cold start
- **Test** Trap – Test trap invoked by user via the Text Interface (CLI.)
- **Alarm** Trap – Trap indicating an alarm condition. A trap with a unique enterprise OID is defined for every possible alarm in the system, under which several specific trap-types are defined to indicate the setting or clearing of that particular alarm condition.

14. Setting Up SSL Encryption

This section describes the procedure for setting up a secure connection via an HTTPS web connection to the Elite Managed Power Controller.

Note:

SSL parameters cannot be defined via the Web Browser Interface. In order to set up SSL encryption, you must contact the Elite Managed Power Controller via the Text Interface.

There are two different types of https security certificates: “Self Signed” certificates and “Signed” certificates.

Self Signed certificates can be created by the Elite Managed Power Controller, without the need to go to an outside service, and there is no need to set up your domain name server to recognize the unit. The principal disadvantage of Self Signed certificates, is that when you access the command mode via the Web Browser Interface, the browser will display a message which warns that the connection might be unsafe. Note however, that even though this message is displayed, communication will still be encrypted, and the message is merely a warning that the Elite Managed Power Controller is not recognized and that you may not be connecting to the site that you intended.

Signed certificates must be created via an outside security service (e.g., VeriSign®, Thawte™, etc.) and then uploaded to the unit to verify the user’s identity. In order to use Signed certificates, you must contact an appropriate security service and set up your domain name server to recognize the name that you will assign to the unit (e.g., service.yourcompany.com.) Once a signed certificate has been created and uploaded to the Elite Managed Power Controller, you will then be able to access command mode without seeing the warning message that is normally displayed for Self Signed certificate access.

```
WEB ACCESS:

HTTP:
1. Enable: On
2. Port: 80

HTTPS:
3. Enable: On
4. Port: 443

SSL Certificates:
5. Common Name:
6. State or Province:
7. Locality:
8. Country:
9. Email Address:
10. Organization Name:
11. Organizational Unit:
12. Create CSR:
13. View CSR:
14. Import CRT:

Enter: #<CR> to change,
      <ESC> to return to previous menu ...
```

Figure 14-1: Web Access Parameters (Text Interface Only)

14.1. Creating a Self Signed Certificate

To create a Self Signed certificate, access the Text interface via Telnet or SSH, using a password that permits Administrator level commands and then proceed as follows:

1. Type **/N** and press **[Enter]** to display the Network Parameters menu.
2. At the Network Parameters menu, type **23** and press **[Enter]** to display the Web Access menu (Figure 14-1.) Type **3** and press **[Enter]** and then follow the instructions in the resulting submenu to enable HTTPS access.
3. Next, use the Web Access menu to define the following parameters:

Note:

When configuring the Elite Managed Power Controller, make certain to define all of the following parameters. Although most SSL applications require only the Common Name, in the case of the Elite Managed Power Controller all of the following parameters are mandatory.

- **5. Common Name:** A domain name, that will be used to identify the Elite Managed Power Controller unit. If you will use a Self Signed certificate, then this name can be any name that you choose, and there is no need to set up your domain name server to recognize this name. However, if you will use a Signed certificate, then your domain name server must be set up to recognize this name (e.g., service.yourcompany.com.)
 - **6. State or Province:** The name of the state or province where the Elite Managed Power Controller unit will be located (e.g., California.)
 - **7. Locality:** The city or town where the Elite Managed Power Controller unit will be located (e.g., Irvine.)
 - **8. Country:** The two character country code for the nation where the Elite Managed Power Controller will be located (e.g., US.)
 - **9. Email Address:** An email address, that can be used to contact the person responsible for the Elite Managed Power Controller (e.g., jsmith@yourcompany.com.)
 - **10. Organizational Name:** The name of your company or organization (e.g., Yourcompany Inc.)
 - **11. Organizational Unit:** The name of your department or division; if necessary, any random text can be entered in this field (e.g., tech support.)
4. After you have defined parameters 5 through 11, type **12** and press **[Enter]** (Create CSR) to create a Certificate Signing Request. By default, this will overwrite any existing certificate, and create a new Self Signed certificate.
- a) The Elite Managed Power Controller will prompt you to create a password. Key in the desired password (up to 16 characters) and then press **[Enter]**. When the unit prompts you to verify the password, key it again and then press **[Enter]** once more. After a brief pause, the unit will return to the Web Access Menu, indicating that the CSR has been successfully created.
 - b) When the Web Access Menu is re-displayed, press **[Esc]** several times until you exit from the Network Parameters menu and the “Saving Configuration” message is displayed.

5. After the new configuration has been saved, test the Self Signed certificate by accessing the Elite Managed Power Controller via the Web Interface, using an HTTPS connection.
 - a) Before the connection is established, the Elite Managed Power Controller should display the warning message described previously. This indicates that the Self Signed certificate has been successfully created and saved.
 - b) Click on the “Yes” button to proceed. The Elite Managed Power Controller will prompt you to enter a user name and password. After keying in your password, the main menu should be displayed, indicating that you have successfully accessed command mode.

14.2. Creating a Signed Certificate

To create a Signed certificate, and eliminate the warning message, first set up your domain name server to recognize the Common Name (item 5) that you will assign to the unit. Next, complete steps one through five as described in Section 14.1 and then proceed as follows:

1. **Capture the Newly Created Certificate:** Type **13** and press **[Enter]** (View CSR). The Elite Managed Power Controller will prompt you to configure your communications (Telnet) program to receive the certificate. Set up your communications program to receive a binary file, and then press **[Enter]** to capture the file and save it. This is the Code Signing Request that you will send to the outside security service (e.g., VeriSign, Thawte, etc.) in order to have them sign and activate the certificate.
2. **Obtain the Signed Certificate:** Send the captured certificate to the outside security service. Refer to the security service's web page for further instructions.
3. **Upload the Signed Certificate to the Elite Managed Power Controller:** After the "signed" certificate is returned from the security service, return to the Web Access menu.
 - a) Access the Elite Managed Power Controller command mode via the Text Interface using an account that permits Administrator level commands as described previously, then type **/n** and press **[Enter]** to display the Network Parameters menu, and then type **23** and press **[Enter]** to display the Web Access menu.
 - b) From the Web Access menu, type **14** and press **[Enter]** (Import CRT) to begin the upload process. At the CRT Server Key submenu, type **1** and press **[Enter]** to choose "Upload Server Key."
 - c) Use your communications program to send the binary format Signed Certificate to the Elite Managed Power Controller unit. When the upload is complete, press **[Escape]** to exit from the CRT Server Key submenu.
 - d) After you exit from the CRT Server Key submenu, press **[Escape]** several times until you have exited from the Network Parameters menu and the "Saving Configuration" message is displayed.

4. After the configuration has been saved, test the signed certificate by accessing the Elite Managed Power Controller via the Web Browser Interface, using an HTTPS connection. For example, if the common name has been defined as “service.yourcompany.com”, then you would enter “**https://service.yourcompany.com**” in your web browser’s address field. If the Signed Certificate has been properly created and uploaded, the warning message should no longer be displayed.

15. Saving and Restoring Configuration Parameters

Once the Elite Managed Power Controller is properly configured, parameters can be downloaded and saved as an ASCII text file. Later, if the configuration is accidentally altered, the saved parameters can be uploaded to automatically reconfigure the unit without the need to manually assign each parameter.

Saved parameters can also be uploaded to other Elite Managed Power Controller units, allowing rapid set-up when several identical units will be configured with the same parameters.

The “Save Parameters” procedure can be performed from any terminal emulation program that allows downloading of ASCII files (e.g. HyperTerminal™, TeraTerm©, etc.).

Note:

The Save and Restore features described in this section are only available via the Text Interface.

15.1. Sending Parameters to a File

1. Start your terminal emulation program and access the Text Interface command mode using an account that permits Administrator level commands.
2. When the command prompt appears, type `/U` and press **[Enter]**. The Elite Managed Power Controller will prompt you to configure your terminal emulation program to receive an ASCII download.
 - a) Set your terminal emulation program to receive an ASCII download, and then specify a name for a file that will receive the saved parameters (e.g. `psv_parameters.PAR`).
 - b) Disable the Line Wrap function for your terminal emulation program. This will prevent command lines from being broken in two during transmission.

3. When the terminal emulation program is ready to receive the file, return to the Elite Managed Power Controller's Save Parameter File menu, and press **[Enter]** to proceed. Parameters will be saved on your hard drive in the file specified in Step 2 above.
4. The Elite Managed Power Controller will send a series of ASCII command lines which specify currently selected parameters. When the download is complete, press **[Enter]** to return to the command prompt.

15.2. Restoring Saved Parameters

This section describes the procedure for using your terminal emulation program to send saved parameters to the Elite Managed Power Controller.

1. Start your terminal emulation program and access the Elite Managed Power Controller's command menu via the Text Interface, using a username/password that permits access to Administrator level commands (see Section 5.1.1.).
2. Configure your terminal emulation program to upload an ASCII text file.
3. Upload the ASCII text file with the saved parameters. If necessary, key in the file name and directory path.
4. Your terminal emulation program will send the ASCII text file to the Elite Managed Power Controller. When the terminal program is finished with the upload, make certain to terminate the Upload mode.

Note:

If the Elite Managed Power Controller detects an error in the file, it will respond with the "Invalid Parameter" message. If an error message is received, carefully check the contents of the parameters file, correct the problem, and then repeat the Upload procedure.

5. If the parameter upload is successful, the Elite Managed Power Controller will send a confirmation message, and then return to the command prompt. Type **/S** and press **[Enter]**, the Status Screen will be displayed. Check the Status Screen to make certain the unit has been configured with the saved parameters.

15.3. Restoring Previously Saved Parameters

If you make a mistake while configuring the Elite Managed Power Controller unit, and wish to return to the previously saved parameters, the Text Interface's "Reboot System" command (/I) offers the option to reinitialize the unit using previously backed up parameters. This allows you to reset the Elite Managed Power Controller to previously saved parameters, even after you have changed parameters and saved them.

Notes:

- **The Elite Managed Power Controller will automatically backup saved parameters once a day, shortly after Midnight. This configuration backup file will contain only the most recently saved parameters, and will be overwritten by the next night's daily backup.**
- **When the /I command is invoked, a submenu will be displayed which offers several Reboot options. Options 4 and 5 are used to restore the configuration backup file. The dates shown next to options 4 and 5 indicate the date that you last changed and saved unit parameters.**
- **If the daily automatic configuration backup has been triggered since the configuration error was made, and the previously saved configuration has been overwritten by newer, incorrect parameters, then this function will not be able to restore the previously saved (correct) parameters.**

To restore the previously saved configuration, proceed as follows:

1. Access command move via the Text Interface, using a username/password that permits access to Administrator level commands (see Section 5.1.1.)
2. At the Elite Managed Power Controller command prompt, type **/I** and press **[Enter]**. The unit will display a submenu that offers several different reboot options.

3. At the submenu, you may choose either Item 4 (Reboot & Restore Last Known Working Configuration) or Item 5 (Restore Last Known Working Configuration.) Key in the number for the desired option, and then press **[Enter]**.

Note:

When invoking the /l command to restore configuration parameters, Item 4 is recommended.

4. The Elite Managed Power Controller will reboot and previously saved parameters will be restored.

16. Upgrading Firmware

When new, improved versions of the Elite Managed Power Controller firmware become available, the “Upgrade Firmware” function can be used to update the unit. Updates can be uploaded via FTP or SFTP protocols.

Notes:

- **The FTP/SFTP servers can only be started via the Text Interface.**
 - **All other ports will remain active during the firmware upgrade procedure.**
 - **If the upgrade includes new parameters or features not included in the previous firmware version, these new parameters will be set to their default values.**
 - **The upgrade procedure will require approximately 15 minutes for your local Elite Managed Power Controller unit, plus 30 minutes for each attached AUX/Remote unit.**
1. Obtain the update file. Firmware modifications can either be mailed to the customer, or downloaded. Place the upgrade CDR in your disk drive or copy the file to your hard drive.
 2. Access Text Interface command mode via Serial Port, Telnet or SSH client session, using a username/password and port that permit Administrator level commands.

3. When the command prompt appears, type **/UF** and then press **[Enter]**. The Elite Managed Power Controller will display a screen which offers the following options:
 - a) **Start FTP/SFTP Servers Only (Do NOT default parameters):** To proceed with the upgrade, while retaining user-defined parameters, type **1** and press **[Enter]**. All existing parameter settings will be restored when the upgrade is complete.
 - b) **Start FTP/SFTP Servers & Default (Keep IP parameters & SSH Keys):** To proceed with the upgrade and default all user-defined parameters except for the IP Parameters and SSH Keys, type **2** and press **[Enter]**. When the upgrade is complete, all parameter settings except the IP Parameters and SSH Keys, will be reset to factory default values.
 - c) **Start FTP/SFTP Servers & Default (Default ALL parameters):** To proceed with the upgrade, and reset parameters to default settings, type **3** and press **[Enter]**. When the upgrade is complete, all parameters will be set to default values.

Note that after any of the above options is selected, the Elite Managed Power Controller will start the receiving servers and wait for an FTP/SFTP client to make a connection and upload a valid firmware binary image.

4. To proceed with the upgrade, select either option 1 or option 2. The Elite Managed Power Controller will display a message that indicates that the unit is waiting for data. Leave the current Telnet/SSH client session connected at this time.
5. Open your FTP/SFTP application and (if you have not already done so,) login to the Elite Managed Power Controller unit, using a username and password that permit access to Administrator level commands.
6. Transfer the md5 format upgrade file to the Elite Managed Power Controller.

7. After the file transfer is complete, the Elite Managed Power Controller will install the upgrade file and then reboot itself and break all port connections. Note that it will take approximately 10 minutes to complete the installation process. The unit will remain accessible until it reboots.
 - a) Some FTP/SFTP applications may not automatically close when the file transfer is complete. If this is the case, you may close your FTP/SFTP client manually after it indicates that the file has been successfully transferred.
 - b) When the upgrade process is complete, the Elite Managed Power Controller will send a message to all currently connected network sessions, indicating that the Elite Managed Power Controller is going down for a reboot.

Note:

Do not power down the Elite Managed Power Controller unit while it is in the process of installing the upgrade file. This can damage the unit's operating system.

8. If you have accessed the Elite Managed Power Controller via the Network Port, in order to start the FTP/SFTP servers, the Elite Managed Power Controller will break the network connection when the system is reinitialized.
 - If you initially selected “Start FTP/SFTP Servers and Save Parameters”, you may then reestablish a connection with the Elite Managed Power Controller using your former IP address.
 - If you initially selected “Start FTP/SFTP Servers and Default Parameters”, you must then login using the Elite Managed Power Controller's default IP address (Default = 192.168.168.168) or access command mode via Serial Port 1 or 2 or via Modem.

When firmware upgrades are available, the necessary files will be provided via download or mailed CDR. At that time, an updated Users Guide or addendum will also be available.

17. Command Reference Guide

17.1. Command Conventions

Most commands described in this section conform to the following conventions:

- **Text Interface:** Commands discussed in this section, can only be invoked via the Text Interface. These commands cannot be invoked via the Web Browser Interface.
- **Slash Character:** Most Text Interface commands begin with the Slash Character (/).
- **Apply Command to All Plugs:** When an asterisk is entered as the argument of the **/ON** (Switch Plugs On), **/OFF** (Switch Plugs Off) or **/BOOT** (Reboot Plugs) commands, the command will be applied to all plugs. For example, to reboot all allowed plugs, type **/BOOT * [Enter]**.
- **Command Queues:** If a switching or reboot command is directed to a plug that is already being switched or rebooted by a previous command, then the new command will be placed into a queue until the plug is ready to receive additional commands.
- **“Busy” Plugs:** If the “Status” column in the Plug Status Screen includes an asterisk, this means that the plug is currently busy, and is in the process of completing a previously issued command. If a new command is issued to a busy plug, then the new command will be placed into a queue to be executed later, when the plug is ready to receive additional commands.
- **Plug Name Wild Card:** Plug names can be abbreviated in command lines by entering the first character(s) of the name followed by an asterisk (*). For example, a plug named “SERVER” can be specified as “S*”. Note however, that this command would also be applied to any other plug name that begins with an “S”.
- **Suppress Command Confirmation Prompt:** When the **/ON** (Switch Plug On), **/OFF** (Switch Plug Off), **/BOOT** (Reboot Plug) or **/DPL** (Default All Plugs) commands are invoked, the “, Y” option can be included to override the Command Confirmation (“Sure?”) prompt. For example, to reboot Plug A4 without displaying the Sure prompt, type **/BOOT A4 , Y [Enter]**.
- **Enter Key:** Most commands are invoked by pressing **[Enter]**.
- **Configuration Menus:** To exit from a configuration menu, press **[Esc]**.

17.2. Command Summary

Function	Command Syntax	Command Access Level			
		Admin.	SuperUser	User	ViewOnly
Display					
Plug Status	/S [Enter]	X ^❶	X ^❶	X ^❶	X ^❶
Plug Group Status	/SG [Enter]	X ^❷	X ^❷	X ^❷	X ^❷
Network Status	/SN [Enter]	X	X	X	X
Help Menu	/H [Enter]	X ^❸	X ^❸	X ^❸	X ^❸
Log Functions	/L [Enter]	X	X		
Current Metering	/M [Enter]	X	X		
Site ID / Unit Information	/J [*] [Enter] ^❹	X	X	X	X
Control					
Exit Command Mode	/X [Enter]	X	X	X	X
Boot Plug <i>n</i>	/BOOT < <i>n</i> >[, Y] [Enter] ^❺	X	X	X	
Turn Plug <i>n</i> On	/ON < <i>n</i> >[, Y] [Enter] ^❻	X	X	X	
Turn Plug <i>n</i> Off	/OFF < <i>n</i> >[, Y] [Enter] ^❼	X	X	X	
Default All Plugs	/DPL[, Y] [Enter] ^❻	X	X	X	
Connect to Port	/C [<i>n</i>] [Enter] ^❻	X	X	X	
Send Parameter File	/U [Enter]	X			
Send SSH Keys	/K < <i>n</i> > [Enter]	X			
Unlock Invalid Access	/UL [Enter]	X			
Configuration					
System Parameters	/F [Enter]	X			
Serial Port Parameters	/P [Enter]	X	❷		
Plug Parameters	/PL [Enter]	X	❷		
Plug Group Parameters	/G [Enter]	X	❷		
Network Configuration	/N [Enter]	X	❷		
Reboot Options	/RB [Enter]	X	❷		
Alarm Configuration	/AC [Enter]	X	❷		
Reboot System	/I [Enter]	X			
Upgrade Firmware	/UF [Enter]	X			
Test Network Configuration	/TEST [Enter]	X			

- ❶ In Administrator Mode and SuperUser Mode, all outlets are displayed. In User Mode and ViewOnly Mode, the Plug Status Screen will only include the plugs allowed by your account.
- ❷ In Administrator Mode, all Plug Groups are displayed. In SuperUser, User and ViewOnly Mode, the Plug Group Status Screen will only include Plug Groups allowed by your account.
- ❸ In Administrator Mode, the Help Menus will list all commands. In the SuperUser, User and ViewOnly Mode, the Help Menus will only list the commands allowed by the access level.
- ❹ If the optional asterisk (*) argument is included in the command line, this command will also show model numbers, current ratings and software versions for the units.
- ❺ The “Y” argument can be included to suppress the command confirmation prompt.
- ❻ The /C command can only be used to connect to the Remote and AUX ports when those ports have been specifically configured as serial ports.
- ❼ In SuperUser Mode, configuration menus can be displayed, but parameters cannot be changed.

17.3. Command Set

This Section provides information on all Text Interface commands, sorted by functionality

17.3.1. Display Commands

/S Display Plug Status Screen

Displays the Plug Status Screen, which lists the current On/Off state, plus the plug number, plug name, Boot/Sequence Delay value and Default On/Off value for each plug. For more information, please refer to Section 8.2.

Note:

In Administrator Mode and SuperUser Mode, all Elite Managed Power Controller outlets are displayed. In User Mode and ViewOnly Mode, the Plug Status Screen will only include the plugs allowed by your account.

Availability: Administrator, SuperUser, User, ViewOnly

Format: /S [Enter]

/SG Display Plug Group Status Screen

Displays the Plug Group Status Screen, which lists the available Plug Groups, the numbers of the plugs included in each Plug Group, the current On/Off state, the user-defined Boot/Sequence Delay value, and the Default On/Off value for each plug. For more information, please refer to Section 8.3.

Note:

In Administrator Mode all user defined Plug Groups are displayed. In SuperUser Mode, User Mode and ViewOnly Mode, the Plug Group Status Screen will only include the Plug Groups allowed by your account.

Availability: Administrator, SuperUser, User, ViewOnly

Format: /SG [Enter]

/SN Display Network Status

Displays the Network Status Screen, which lists current network connections to the Elite Managed Power Controller's Network Port. For more information, please refer to Section 8.1.

Availability: Administrator, SuperUser, User, ViewOnly

Format: /SN [Enter]

/H Help

Displays a Help Screen, which lists all available Text Interface commands along with a brief description of each command.

Note:

In the Administrator Mode, the Help Screen will list the entire Text Interface command set. In SuperUser Mode, User Mode and ViewOnly Mode, the Help Screen will only list the commands that are allowed by the access level.

Availability: Administrator, SuperUser, User, ViewOnly

Format: /H [Enter]

/L Log Functions

Provides access to a menu which allows you to display the Audit Log, Alarm Log Current Metering Log and Power Metering Log. For more information on Log Functions, please refer to Section 5.3.4 and Section 8.

Availability: Administrator, SuperUser

Format: /L [Enter]

/M Current Metering Status

Displays the Current Metering Status Screen, which lists current, voltage and power readings, and also lists the trigger settings for the Over Temperature Alarm and the Over Current Alarm. When one or more AUX/Remote Elite Managed Power Controller units are connected to your local unit, the Current Metering Status screen will also show current levels at the AUX/Remote units. For more information on Current Metering, please refer to Section 8.4. For more information on Alarm Configuration, please refer to Section 7.

Availability: Administrator, SuperUser

Format: /M [Enter]

/J Display Site ID / Unit Information

Displays the user-defined Site I.D. message. If the optional asterisk (*) argument is included in the command line, the command will also show model numbers, current ratings, and software versions for the local unit, as well as any remote Elite Managed Power Controller units that may be connected to the AUX ports.

Availability: Administrator, SuperUser, User, ViewOnly

Format: /J [*] [Enter]

Where * (asterisk) is an optional command argument, that is used to display the model number, current rating and software version for the local unit, as well as any remote units that may be connected to the AUX ports.

17.3.2. Control Commands

/X Exit Command Mode

Exits command mode. When issued at the Network Port, also ends the Telnet session.

Note:

If the /X command is invoked from within a configuration menu, recently defined parameters may not be saved. In order to make certain that parameters are saved, always press the [Esc] key to exit from all configuration menus and then wait until “Saving Configuration” message has been displayed and the cursor has returned to the command prompt before issuing the /X command.

Availability: Administrator, SuperUser, User, ViewOnly

Format: /X [Enter]

/BOOT Initiate Boot Cycle

Initiates a boot cycle at the selected plug(s) or Plug Group(s). When a Boot cycle is performed, the unit will first switch the selected plug(s) Off, then pause for the user-defined Boot/Sequence Delay Period, then switch the plug(s) back on. The /BOOT command can also be entered as /BO.

Note:

When this command is invoked in Administrator Mode or SuperUser Mode, it can be applied to all plugs and Plug Groups. When this command is invoked in User Mode, it can only be applied to the plugs and/or Plug Groups that have been enabled for the account.

Availability: Administrator, SuperUser, User

Format: /BOOT [**aux**] <**n**>[,**Y**] [Enter] or /BO [**aux**] <**n**> [Enter]

Where:

- aux** If you are directing the command to an outlet on an AUX/Remote unit, then the **aux** argument must be included in the command line in order to route the command to the appropriate unit. If your local unit is not connected to AUX/Remote units, then there is no need to include this argument in the command line.
- n** The number or name of the plug(s) or Plug Group(s) that you intend to boot. To apply the command to several plugs, enter a plus sign (+) between each plug number. To apply the command to a range of plugs, enter the numbers for the first and last plugs in the range, separated by a colon character (:). To apply the command to all plugs allowed by your account, enter an asterisk character (*).
- ,Y** (Optional) Suppresses the command confirmation prompt.

Examples:

Assume that your account allows access to Plug A2 and Plug A3. To initiate a boot cycle at Plugs A2 and A3, without displaying the optional command confirmation prompt, invoke either of the following command lines:

/BOOT A2+A3,Y [Enter] or /BO A2+A3,Y [Enter]

To direct the /BOOT command to plug B4 on an AUX/Remote unit connected to the AUX2 port on your local unit, invoke either of the following command lines:

/BOOT aux2 B4 [Enter] or /BO aux2 B4 [Enter]

/ON Switch Plug(s) ON

Switches selected plugs(s) or Plug Group(s) On, as described in Section 9.2.2. When the /ON command is used to switch more than one plug, Boot/Sequence Delay Period will be applied as described in Section 5.7.

Note:

When this command is invoked in Administrator Mode or SuperUser Mode, it can be applied to all plugs and Plug Groups. When this command is invoked in User Mode, it can only be applied to the plugs and/or Plug Groups that have been enabled for the account.

Availability: Administrator, SuperUser, User

Format: /ON [**aux**] <**n**>[, **Y**] [Enter]

Where:

- aux** If you are directing the command to an outlet on an AUX/Remote unit, then the **aux** argument must be included in the command line in order to route the command to the appropriate AUX/Remote unit. If your local unit is not connected to AUX/Remote units, then there is no need to include this argument in the command line.
- n** The number or name of the plug(s) or Plug Group(s) that you intend to Switch On. To apply the command to several plugs, enter a plus sign (+) between each plug number. To apply the command to a range of plugs, enter the numbers for the first and last plugs in the range, separated by a colon (:). To apply the command to all plugs allowed by your account, enter an asterisk character (*).
- , Y** (Optional) Suppresses the command confirmation prompt.

Examples:

Assume that your account allows access to Plug A2 and Plug A3. To switch Plugs A2 and A3 On, without displaying the optional command confirmation prompt, invoke following command line:

```
/ON A2+A3, Y [Enter]
```

To direct the /ON command to plug B4 on an AUX/Remote unit connected to the AUX2 port on your local unit, invoke the following command line:

```
/ON aux2 B4 [Enter]
```

/OFF Switch Plug(s) OFF

Switches selected plugs(s) or Plug Group(s) Off, as described in Section 9.2.2. When the /OFF command is used to switch more than one plug, Boot/Sequence Delay Period will be applied as described in Section 5.7. The /OFF command can also be entered as /OF.

Note:

When this command is invoked in Administrator Mode or SuperUser Mode, it can be applied to all plugs and Plug Groups. When invoked in User Mode, the command can only be applied to the plugs and/or Plug Groups that are enabled for the account.

Availability: Administrator, SuperUser, User

Format: /OFF [**aux**] <**n**>[,**Y**] [Enter] or /OF <**n**>[,**Y**] [Enter]

Where:

- aux** If you are directing the command to an outlet on an AUX/Remote unit, then the **aux** argument must be included in the command line in order to route the command to the appropriate AUX/Remote unit. If your local unit is not connected to AUX/Remote units, then there is no need to include this argument in the command line.
- n** The number or name of the plug(s) or Plug Group(s) that you intend to Switch Off. To apply the command to several plugs, enter a plus sign (+) between each plug number. To apply the command to a range of plugs, enter the numbers for the first and last plugs in the range, separated by a colon character (:). To apply the command to all plugs allowed by your account, enter an asterisk character (*).
- ,Y** (Optional) Suppresses the command confirmation prompt.

Examples:

Assume that your account allows access to Plug A2 and Plug A3. To switch Plugs A2 and A3 on your local unit Off, without displaying the optional command confirmation prompt, invoke either of the following command lines:

/OFF A2+A3,Y [Enter] or /OF A2+A3,Y [Enter]

To direct the /OFF command to plug B4 on an AUX/Remote unit connected to the AUX2 port on your local unit, invoke either of the following command lines:

/OFF aux2 B4 [Enter] or /OF aux2 B4 [Enter]

/DPL Set All Plugs to Default States

Sets all switched outlets to their user-defined default state. For information on setting outlet defaults, please refer to Section 5.7.

Notes:

- **When this command is invoked in Administrator Mode or SuperUser Mode, it will be applied to all outlets. When invoked in User Mode, the command will only be applied to the plugs that are allowed by the account.**
- **If one or more optional AUX/Remote Elite Managed Power Controller units are connected to the AUX ports on your local unit, then the /DPL command will be applied to both the local unit as well as the AUX/Remote units.**

Availability: Administrator, SuperUser, User

Format: /DPL[,Y] [Enter]

Where ,Y is an optional command argument, which can be included to suppress the command confirmation prompt.

/C Connect to Serial Port

When the RJ-45 AUX Ports and/or Remote Port have been configured as Serial Ports as described in Section 5.8.2, the /C command can be used to create a connection between the Network port and a serial mode AUX or Remote Port. In addition, the /C command can also be invoked to create a connection between the Network Port and the Console Port.

Notes:

- **User level accounts can only connect to the ports that are specifically permitted by the account.**
- **The /C command cannot be used to create a connection between two serial ports.**
- **Administrator and SuperUser level accounts are allowed to connect to any Elite Managed Power Controller Serial Port.**
- **To terminate a serial port connection, either type ^X ([Ctrl] plus [X]) or invoke the currently defined disconnect sequence.**

Availability: Administrator, SuperUser, User

Format: /C <x> [Enter]

Where x is the name of the serial port that you wish to connect to. The available ports are “1” (the Console Port), “Remote”, “AUX1”, “AUX2” and “AUX3”.

/U Send Parameters to File

Sends all Elite Managed Power Controller configuration parameters to an ASCII text file as described in Section 13. This allows you to back up the configuration of your Elite Managed Power Controller unit.

Availability: Administrator

Format: /U [Enter]

/K Send SSH Key

Instructs the Elite Managed Power Controller to provide you with a public SSH key for validation purposes. This public key can then be provided to your SSH client, in order to prevent the SSH client from warning you that the user is not recognized when you attempt to create an SSH connection. For more information, please refer to Section 10.

Availability: Administrator

Format: /K *k* [Enter]

Where *k* is a required argument, which indicates the key type. The *k* argument provides the following options: **1** (SSH1), **2** (SSH2 RSA), **3** (SSH2 DSA.)

/UL Unlock Port (Invalid Access Lockout)

Manually cancels the Invalid Access Lockout feature. Normally, when a series of failed login attempts are detected, the Invalid Access Lockout feature can shut down the network port for a user specified time period in order to prevent further access attempts. When the /UL command is invoked, the Elite Managed Power Controller will immediately unlock all network ports that are currently in the locked state.

Availability: Administrator

Format: /UL [Enter]

Response: The Elite Managed Power Controller will unlock all Ports.

17.3.3. Configuration Commands

/F Set System Parameters

Displays a menu which is used to define the Site ID message, create user accounts, set the system clock, and configure and enable the Invalid Access Lockout feature. Note that all functions provided by the /F command are also available via the Web Browser Interface. For more information, please refer to Section 5.3.

Availability: Administrator

Format: /F [Enter]

/P Set Serial Port Parameters

Displays a menu that is used to select options and parameters for the Serial Console Port, Remote Port and AUX Ports. Note that all functions provided by the /P command are also available via the Web Browser Interface. Section 5.8 describes the procedure for defining serial port parameters for both the Console Port and RJ-45 Remote and AUX ports.

Availability: Administrator

Format: /P <n> [Enter]

Where *n* is used to indicate the Console Port or AUX/Remote Ports. The available command arguments are “1” (Console Port) or **AUX** (AUX and Remote Ports).

/PL Set Plug Parameters

Displays a menu that is used to select options and parameters for the switched outlets (plugs). Note that all functions provided by the /PL command are also available via the Web Browser Interface. Section 5.7 describes the procedure for defining plug parameters.

Availability: Administrator

Format: /PL [Enter]

/G Plug Group Parameters

Displays a menu that is used to View, Add, Modify or Delete Plug Groups. For more information on Plug Groups, please refer to Section 5.6.

Availability: Administrator

Format: /G [Enter]

/N Network Port Parameters

Displays a menu which is used to select parameters for the Network Port. Also allows access to the IP Security function, which can restrict network access by unauthorized IP addresses. Note that all of the functions provided by the /N command are also available via the Web Browser Interface. For more information, please refer to Section 5.9.

Availability: Administrator

Format: /N [Enter]

/RB Reboot Options

Displays a menu that is used to configure Scheduled Reboots and Ping-No-Answer Reboots. Scheduled Reboots allow the Elite Managed Power Controller to be rebooted on a regular basis, according to a user defined schedule. Ping-No-Answer Reboots allow the unit to automatically reboot user-designated outlets when a user-specified IP address does not respond to a Ping command. For more information on Reboot options, please refer to Section 6.

Note:

If desired, the Ping-No-Answer Reboot function can also be configured to send email notification whenever a Ping-No-Answer Reboot is generated. For more information, please refer to Section 7.6.

Availability: Administrator

Format: /RB [Enter]

/AC Alarm Configuration Parameters

Displays a menu that is used to configure and enable the Over Current Alarms, Over Temperature Alarms, Circuit Breaker Open Alarm, Lost Communication with AUX Units Alarm, Lost Voltage Alarm, Ping-No-Answer Alarm, and the Invalid Access Lockout Alarm. When properly configured, the Over Current Alarms and Over Temperature Alarms offer the option of “Load Shedding”, which allows the unit to automatically switch Off user-specified non-essential outlets when temperature or current readings exceed user-defined values. For more information on Alarm Configuration, please refer to Section 7.

Availability: Administrator

Format: /AC [Enter]

/I Reboot System (Default)

Reinitializes the Elite Managed Power Controller unit and offers the option to keep user-defined parameters or reset to default parameters. As described in Section 5.10.1, the /I command can also be used to restore the unit to previously saved parameters. When the /I command is invoked, the unit will offer the following reboot options:

- Unit to Reboot
- Reboot Only (Do NOT default parameters)
- Reboot & Default (Keep IP Parameters & SSH Keys; Default all other parameters)
- Reboot & Default (Default ALL parameters)
- Reboot & Restore Last Known Working Configuration
- Restore Last Known Working Configuration

Note:

When optional AUX/Remote Elite Managed Power Controller units have been connected to the AUX ports on your local unit, the “Unit to Reboot” option allows you to specify which unit will be rebooted. When this option is selected, the unit will display an additional submenu, which allows you to select the local unit, any of the AUX units, or all connected Elite Managed Power Controller units.

Availability: Administrator

Format: /I [Enter]

/UF Upgrade Firmware

When new versions of the Elite Managed Power Controller firmware become available, this command is used to update existing firmware as described in Section 15.

Note:

When a firmware upgrade is performed, the Elite Managed Power Controller will require 15 minutes to upgrade your local unit, plus 30 minutes for each optional AUX/Remote unit connected to your local Elite Managed Power Controller unit.

Availability: Administrator

Format: /UF [Enter]

/TEST Test Network Parameters

Displays a menu which is used to test configuration of the Syslog and SNMP Trap functions and can also be used to invoke a Ping Command. For more information, please refer to Section 11.2 and Section 12.2.

Notes:

- **In order for the ping command to function with domain names, Domain Name Server parameters must be defined as described in Section 5.9.5.**
- **The Test Menu's Ping command is not effected by the status of the Network Parameters Menu's Ping Access function.**

Availability: Administrator

Format: /TEST [Enter]

Appendix A. Interface Descriptions

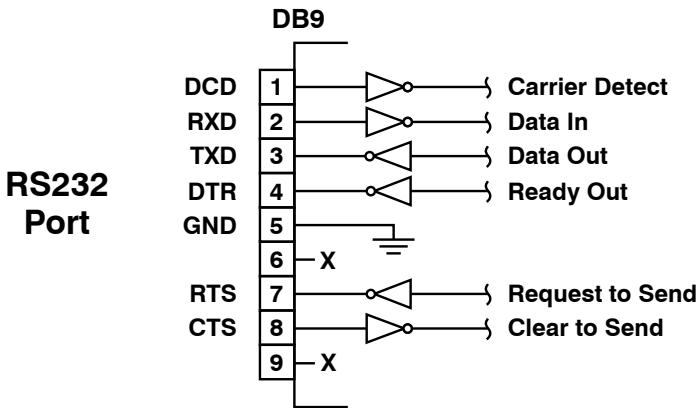

Figure A-1: RS232 Console Port Interface

A.1. Serial Console Port (RS232)

DCD and DTR hardware lines function as follows:

1. When connected:

- a) If either port is set for Modem Mode, the DTR output at either port reflects the DCD input at the other end.
- b) If neither port is set for Modem Mode, DTR output is held high (active).

2. When not connected:

- a) If the port is set for Modem Mode, upon disconnect DTR output is pulsed for 0.5 seconds and then held high.
- b) If the port is not set for Modem Mode, DTR output is controlled by the DTR Output option (Serial Port Parameters Menu, Option 23). Upon disconnect, Option 23 allows DTR output to be held low, held high, or pulsed for 0.5 seconds and then held high.

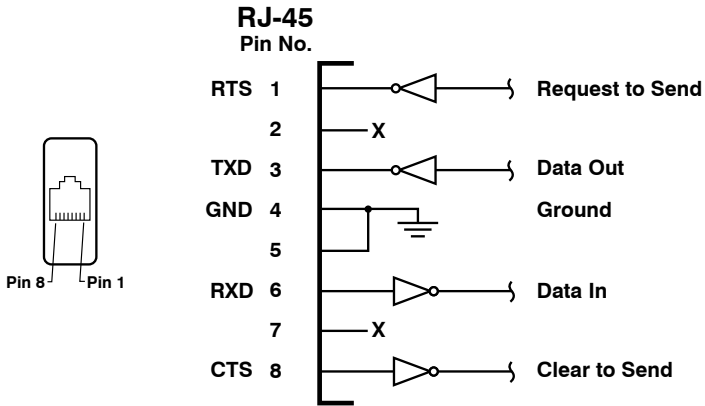

Figure A-2: AUX Port Interface

A.2. RJ-45 AUX Port Interface

The Elite Managed Power Controller AUX Port is described in Figure A-2 above.

Note:

The Elite Managed Power Controller’s AUX ports do not support DTR or DCD lines.

Appendix B. Connecting Devices to AUX & Remote Ports

As discussed in Section 2, the Elite Managed Power Controller unit includes three RJ-45 AUX Ports and one RJ-45 Remote Port. Typically, the AUX ports are used for connection to up to three additional Elite Managed Power Controller units (allowing control of up to 80 plugs.)

Note however, that in addition to their primary functions, the AUX and Remote ports can also be used for connection to routers and other devices as described in this section. For a description of the AUX port interface, please refer to Appendix A.2. For a description of the procedure that is used to configure the AUX and Remote ports for connection to DCE devices, please refer to Section 5.8.2.

B.1. Connecting an Auxiliary Unit to the AUX Port

Use a DX9F-DTE-RJ Snap Adapter and an RJ-45 Straight Cable to connect an optional, Auxiliary Elite Managed Power Controller unit to the AUX Port on your local Elite Managed Power Controller unit as shown in Figure B-1 and Figure B-2 below. For instructions on unit configuration, please refer to Section 5.

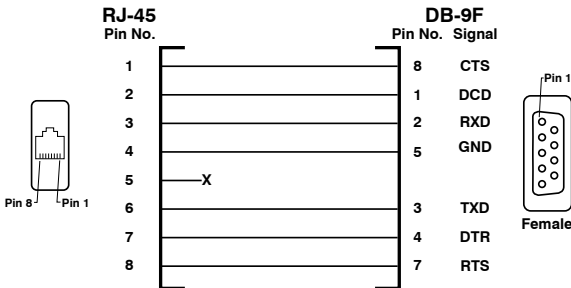

Figure B-1: DX9F-DTE-RJ Snap Adapter Interface

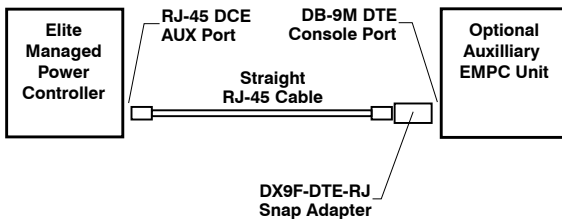

Figure B-2: Connecting an Auxiliary Unit to the Local Unit

B.2. Connecting Other RJ-45 DCE Devices to the AUX & Remote Ports

A standard rollover cable can be used to connect the following RJ-45 DCE devices to the Elite Managed Power Controller's RJ-45 serial ports:

- Cisco Routers with RJ-45 DCE Console Port
- Sun Routers with RJ-45 DCE Console Port
- Other Devices with RJ-45 DCE Console Port

When connecting an RJ-45 DCE device to the Elite Managed Power Controller, please refer to Figure B-3 below:

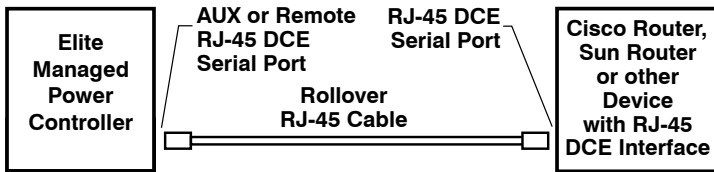

Figure B-3: Connecting RJ-45 DCE Devices to the AUX & Remote Ports

Appendix C. Rack Mounting

The Elite Managed Power Controller offers a variety of different mounting options to allow the unit to be easily mounted in almost any equipment rack available. In addition to the standard “L” brackets included with the unit, vertical format units can also be mounted using mounting buttons or universal mounting ears.

C.1. “L” Bracket Mounting

The standard “L” brackets included with the unit can be used to mount Elite Managed Power Controller units in most standard equipment racks.

The “L” brackets allow horizontal format Elite Managed Power Controller units to be mounted facing forward or facing backward or mounted in the front of the rack or rear of the rack. When the “L” brackets are used with vertical format Elite Managed Power Controllers, units can also be mounted facing either side of the rack.

1. **Attaching the Brackets to the Elite Managed Power Controller:** First determine which direction the unit will face after mounting, and then secure the “L” Brackets accordingly, using the screws provided.
 - a) **Models PSH8-S20-120V, PSH8-S20-208+V, PSH8-D20-120V and PSH8-D20-208+V:** Each end of the unit has four screw holes that are used for mounting the “L” brackets. The “L” brackets can either be mounted facing the front or the rear of the unit, using the same four holes. Use four screws (supplied with the bracket) to secure each bracket to the Elite Managed Power Controller.
 - b) **Models PSH16-D20-120V and PSH16-D20-208+V:** Each end of the unit has eight screw holes; four screw holes for front mounting, and four for rear mounting. Use four screws (supplied with the bracket) to secure an “L” bracket to each side of the unit. If the front of the unit will face outwards, use the front four holes; if the back of the unit will face outward, use the rear four holes.

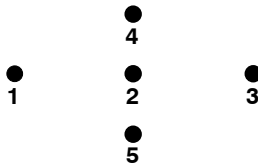

Figure C-1: Mounting Holes; Vertical Units

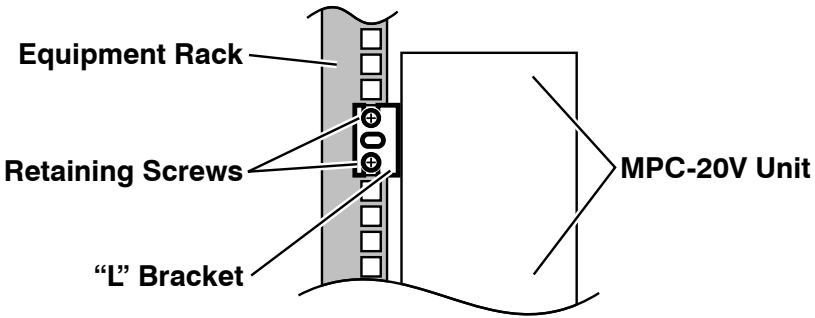

Figure C-2: Attaching “L” Brackets to Equipment Rack (Vertical Unit Shown)

c) **Models PSV20-S20-120V, PSV20-S20-208+V, PSV20-S30-120V and PSV20-S30-208+V (Vertical Units):** The “L” brackets can either be attached to the back or side of the unit, and the unit can also be installed to face the front, rear, or either side of the equipment rack. Each end of the unit features seven screw holes for attaching the brackets, this allows you to mount the brackets on either side of the unit, and in one of two possible positions on the back. When mounting the brackets on the back of the unit, use screw holes 1 and 2 or 2 and 3 as shown in Figure C-1. Use two screws (supplied with the bracket) to secure one bracket to the top of the unit and the second bracket to the bottom of the unit.

2. **Attaching the “L” Brackets to the Equipment Rack:** Determine which direction the Elite Managed Power Controller unit will face in the rack, then line the “U” slots in the “L” Bracket up with two holes in the equipment rack mounting strip. Make certain that the unit is level, and then use two screws to secure each “L” bracket to the rack as shown in Figure C-2.

C.2. Mounting Buttons

The Mounting Buttons allow vertical format units to be mounted in any equipment rack that includes mounting button holes, as shown in Figure C-4. Depending on the location of the mounting button holes in your equipment rack, this can allow the vertical format Elite Managed Power Controller to be mounted on the posts at the rear of the equipment rack, or in some cases, even mounted on the outside of the rack corner posts.

1. **Attaching the Mounting Buttons:** Attach four Mounting Buttons to the back panel of the Elite Managed Power Controller as described below:
 - a) Insert a retaining screw into each Mounting Button with the top of the screw aligned with the large end of the Mounting Button, as shown in Figure C-3.
 - b) Locate the screw holes for the Mounting Buttons on the Elite Managed Power Controller back panel. There are two screw holes at the top of the back panel and two holes at the bottom. Note that the screw holes for the Mounting Buttons are not the same holes shown in Figure C-1; the Mounting Button screw holes are located at the top of the unit, directly above the screw holes shown in Figure C-1, and at the bottom, about three inches below the holes shown in Figure C-1.
 - c) Firmly attach two Mounting Buttons to the screw holes at the top of the Elite Managed Power Controller and two Mounting Buttons to the screw holes at the bottom of the unit.
2. **Attach the Elite Managed Power Controller to the Equipment Rack:** Align the Mounting Buttons with the top end of each mounting button hole (see Figure C-4.) Press the mounting buttons into the mounting button holes, and then slide the unit downwards, so each Mounting Button seats firmly in the lower end of each corresponding mounting button hole.

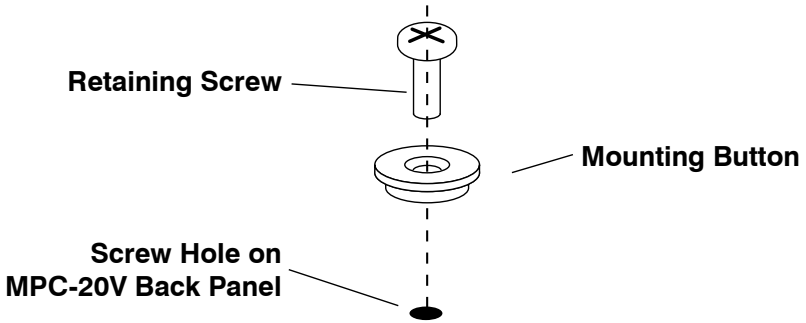

Figure C-3: Attaching Mounting Button to a Vertical Format Unit

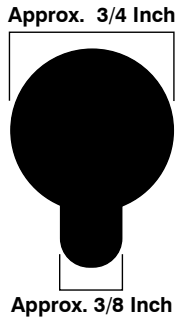

Figure C-4: Mounting Button Holes

C.3. Universal Mounting Bracket

The Universal Mounting Brackets are used to mount vertical format Elite Managed Power Controller units to equipment rack posts or mounting pads. The Universal Mounting Brackets are often used in cases where the power supply cable enters the rack from above, and allow the unit to be easily mounted upside down.

To mount the unit using the Universal Mounting Brackets, proceed as follows:

1. **Attach the Brackets to the Unit:**
 - a) Locate the two pairs of mounting holes at the top and bottom of the Elite Managed Power Controller's back panel. There should be a pair of holes at the top of the back panel and a pair of holes at the bottom.
 - b) Refer to Figure C-5 on the following page, and then use the retainer screws to attach one Universal Mounting Bracket to the top of the back panel, and one Universal Mounting Bracket to the bottom of the back panel. Prior to attaching the mounting brackets, make certain that the beveled edge of the screw holes faces outward, so the head of the screw will nest within the bevel.
2. **Attach the Elite Managed Power Controller to the Rack:**
 - a) Use a retaining screw to secure the top mounting bracket to the equipment rack post or mounting pad as shown in Figure C-6.
 - b) Make certain that the Elite Managed Power Controller hangs level and straight, and then use a retaining screw to attach the bottom mounting bracket to the lower portion of the rack post or mounting pad, securing the unit to the rack.

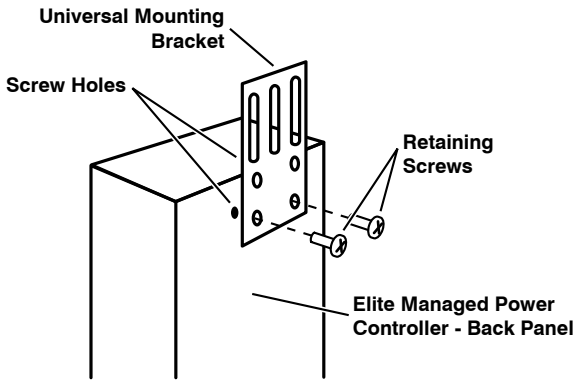

Figure C-5: Attaching the Universal Mounting Bracket to the Unit

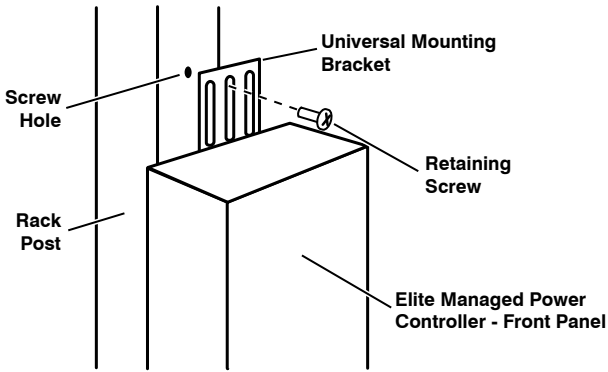

Figure C-6: Attaching the Universal Mounting Brackets to the Rack

Appendix D. Troubleshooting

D.1. Calling Black Box

If you determine that your Elite Managed Power Controller is malfunctioning, do not attempt to alter or repair the unit. It contains no user-serviceable parts. Contact Black Box at 724-746-5500.

Before you do, make a record of the history of the problem. We will be able to provide more efficient and accurate assistance if you have a complete description, including:

- The nature and duration of the problem.
- When the problem occurs.
- The components involved in the problem.
- Any particular application that, when used, appears to create the problem or make it worse.

D.2. Shipping and Packaging

If you need to transport or ship your Elite Managed Power Controller:

- Package it carefully. We recommend that you use the original container.
- If you are shipping the Elite Managed Power Controller for repair, make sure you include everything that came in the original package. Before you ship, contact Black Box to get a Return Authorization (RA) number.



© Copyright 2006. Black Box Corporation. All rights reserved.

1000 Park Drive • Lawrence, PA 15055-1018 • 724-746-5500 • Fax 724-746-0746