



INSTRUCTION BOOK FOR
Professional Electrol®



Pre-Installation

1. Carefully unpack screen.
2. Make sure to recheck measurements of screen location before installation.
3. Remove instruction cover plate (Fig. 2). Do not remove wrapping paper or tape strips until screen is installed.

Ironing Board

Professional Electrols, 14' and over, contain an ironing board to flatten the fabric (long strip attached). The ironing board is part of the screen case. Do not remove or alter (Fig. 1).

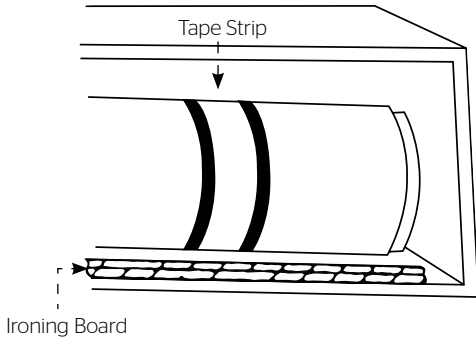

Figure 1

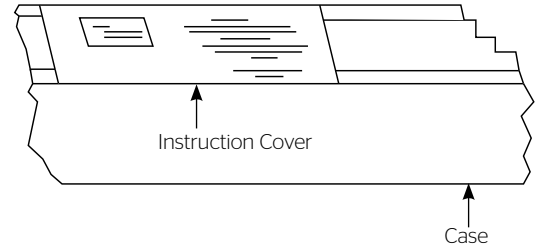

Figure 2

Installation

Hangers (If required)

1. See Figure 3 for hanger placement.
2. Make sure hangers are placed to fit into notches of ironing board.

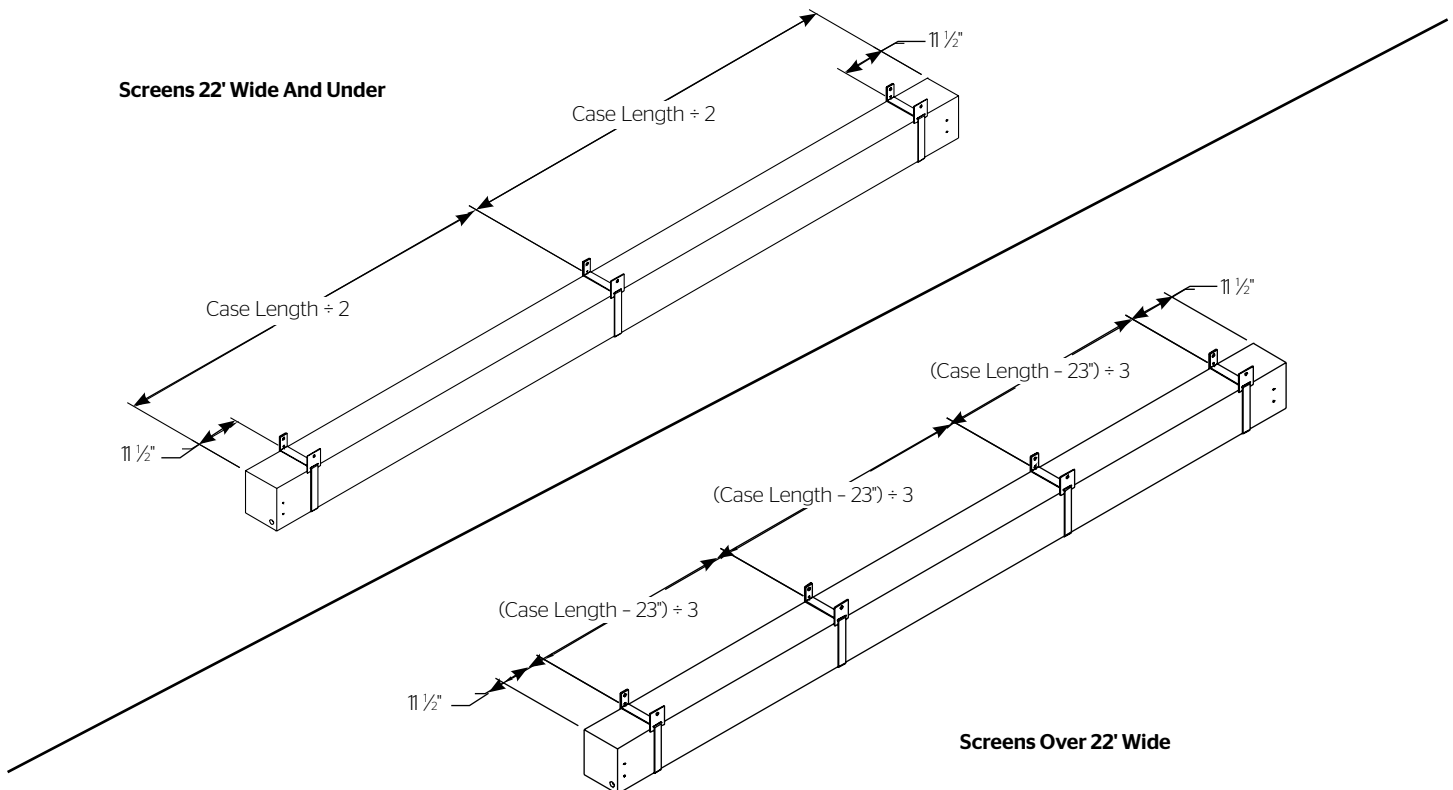

Figure 3

Installation

1. Level unit lengthwise with a carpenter's plum level.

⚠ CAUTION! Do Not completely seal in unit. Access room must be allowed for motor repair or fabric replacement.

2. Remove shipping brace by removing 2 hex head screws (Fig. 4).
3. Remove wrapping paper and tape strips (Fig. 4).

⚠ CAUTION! Do not cut wrapping paper or tape with knife or any sharp tool. Remove by hand.

4. Install electrical hook up that applies to your unit. Make sure to review your Electrical Installation Checklists and wiring diagrams (included) for either 110 volt switch, 220/240 volt switch, or DRC low voltage control.
5. Test installation by carefully running surface up and down several times. Be prepared to stop screen.

NOTE: The picture surface, when rolled down, should have at least a full wrap and a half around the roller. Do not allow any part of the roller to become exposed.

Screen Adjustment

Surface travel is stopped automatically in the fully opened and closed positions by limit switches that are properly adjusted at Da-Lite. Should it be necessary to adjust more or less drop of picture, proceed in the following manner:

⚠ CAUTION! When adjusting and testing, be prepared to stop screen quickly as serious damage may occur.

NOTE: Use a screw driver or allen wrench to make adjustments.

More screen drop

1. Place operating switch in "down" position.
2. When the screen stops, turn the white "down" limit knob (Fig.4) one-quarter turn counterclockwise. Test by raising picture surface approximately two feet, then lower again. Repeat until desired picture surface position is attained.

NOTE: Must leave at least 1-1/2 wraps of fabric on roller.

Less screen drop

1. Raise picture surface approximately two feet above desired level.
2. Place operating switch in "off" position.
3. Turn the white "down" limit switch (Fig. 4) one-quarter turn clockwise. Test by raising picture surface approximately two feet, then lower again. Repeat until desired picture surface position is attained.

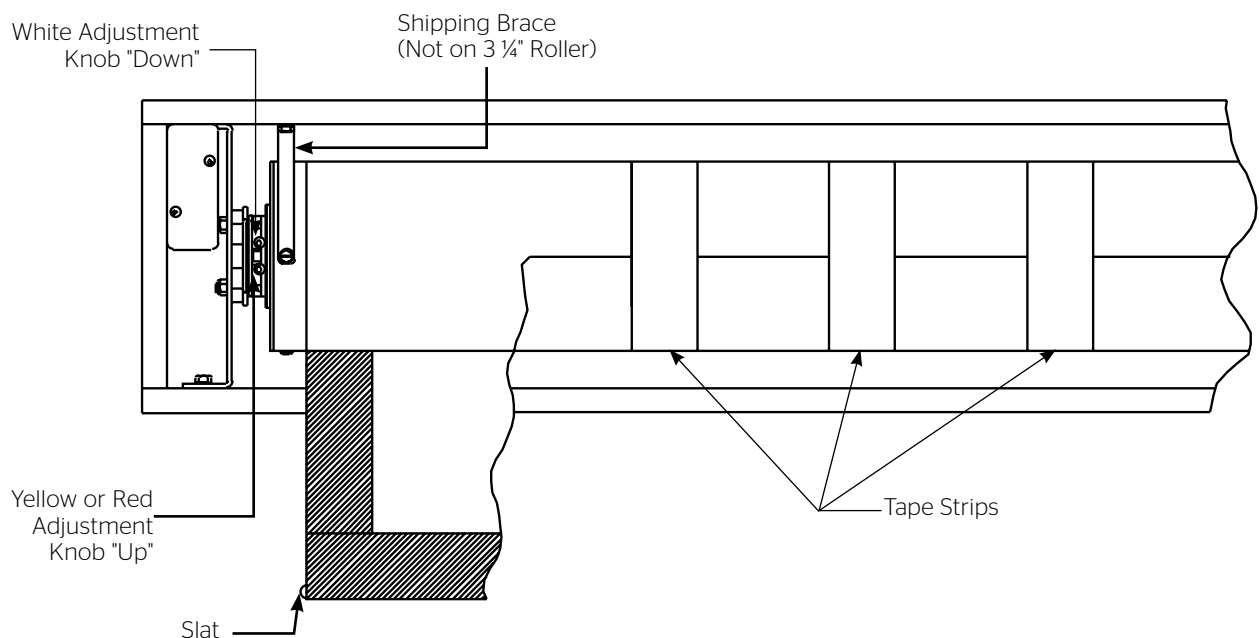
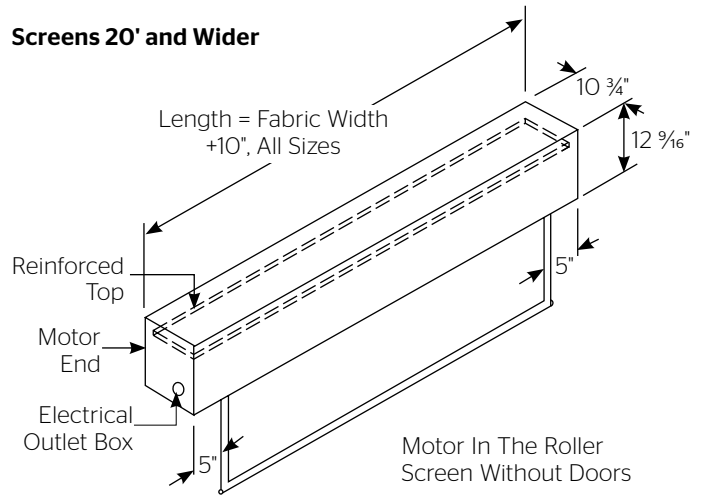
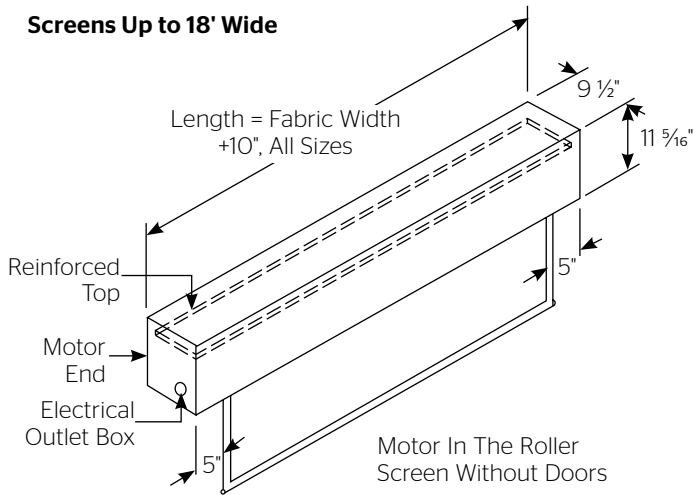

Figure 4



Suggested Methods of Installation

NOTE: For Exposed Installation If the screen is to be mounted in an exposed position, it may be covered with finished plywood, veneer, paneling, plastic wall covering or a valance.

Ceiling Type Hanger

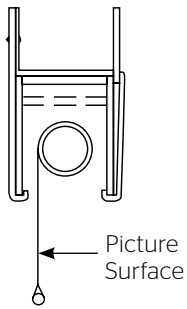

Wall Type Hanger

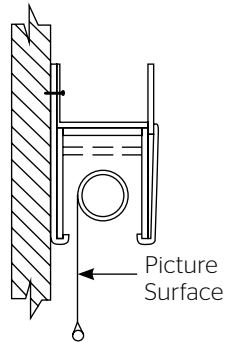

Wall or Ceiling Mount With Hangers

Wall type hangers and ceiling type hangers are standard equipment. One set is supplied with each screen. Useful for recessed installations.

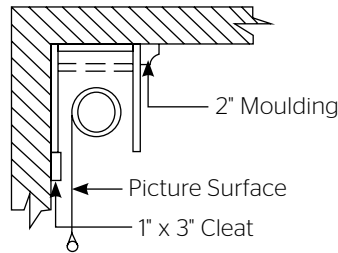

Ceiling Mount Without Hangers

Screen case is placed flush with the wall and ceiling and held in position by moulding securely attached to the wall.

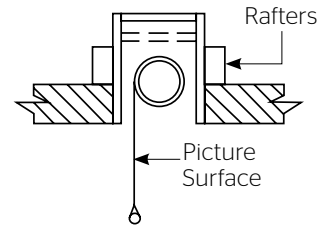

Recessed Above Ceiling

Other methods of installation will suggest themselves in new buildings where it would be an easy matter to provide a recess for the screen to conceal it when not in use.
Do not seal in—allow access.

120V Wiring Diagram

In multiple control installations the switch is replaced by the low voltage control, operated from push button stations.

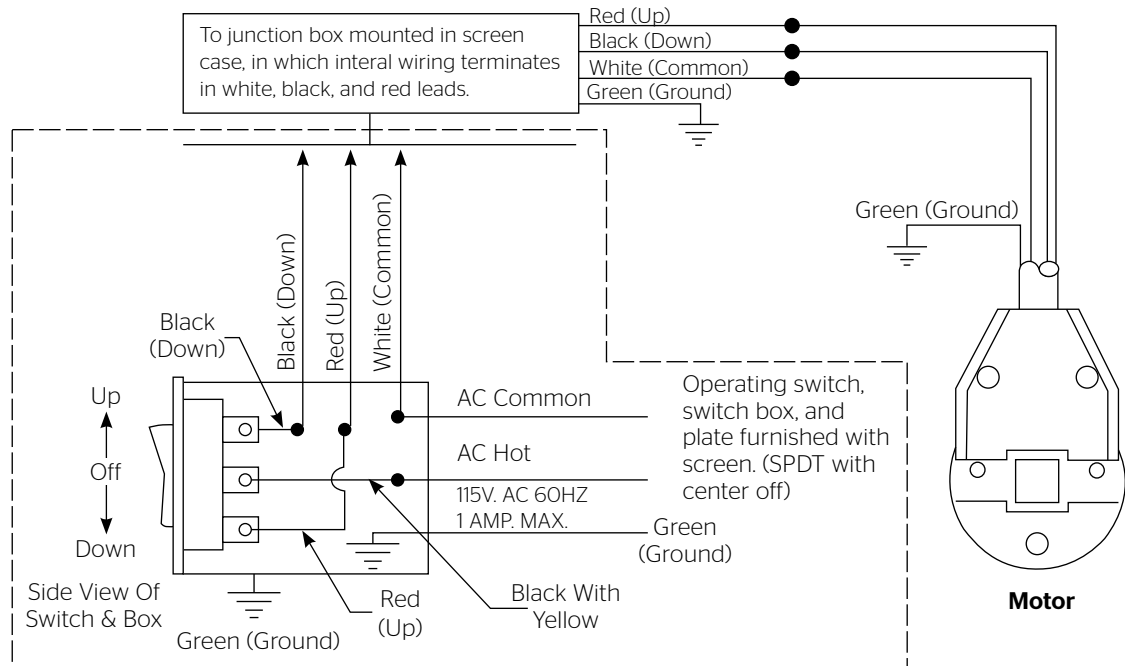

This switch cannot be used with L.V.C.

NOTE: A single switch cannot be used to operate more than one screen. Contract the factory for further information.

240 Volt Wiring Diagram For Standard Wall Switch:

Da-Lite offers two styles of 240 volt wall switches for standard operation. Please see wiring diagram in wall switch box included with screen.

Troubleshooting

Symptom	Cause	Solution
Screen will not operate or will not go "down". Motor does not hum.	Blown facility fuse.	Replace facility fuse.
	Tripped facility circuit breaker.	Reset facility circuit breaker.
	No power to operating switch or junction box.	Check above. Tighten all loose wire connections. Recheck wiring. See installation instructions. "Down" Position Check for power across black and white leads.
	Power at junction box Thermal overload tripped.	Let motor cool down for 15 minutes. Try again.
	Broken wire in the "down" position.	Check for continuity.
	Defective motor, limit switch or capacitor.	Replace motor assembly. NOTE: Motor is a sealed assembly.
	Temporary binding.	With power "off," turn roller by hand to free binding.
Motor hums.	Capacitor burned out.	Replace motor assembly.
Screen will not move upward. Motor does not hum.	Blown facility fuse.	Replace facility fuse.
	Tripped facility circuit breaker.	Reset facility circuit breaker.
	No power to operating switch or junction box.	Check above. Tighten all loose wire connections. See above. "Up" Position Check for power across red and white leads.
	Power at junction box Thermal overload tripped.	Let motor cool down for 15 minutes. Try again.
	Broken wire in the "up" position.	Check for continuity.
	Defective motor, limit switch or capacitor.	Replace motor assembly. NOTE: Motor is a sealed assembly.
	Temporary binding.	With power "off," turn roller by hand to free binding.
Motor hums.	Capacitor burned out.	Replace motor assembly.

Troubleshooting

Symptom	Cause	Solution
"Down" limit switch incorrect.	"Down" limit switch out of adjustment.	See installation instructions.
Noise. NOTE: Screen will operate with a low-pitched hum.	Squeaking, rubber end plug rubbing on motor.	Center roller between mounting brackets by pushing roller away from motor end.
	Grinding. Foreign object in screen rubbing on roller or fabric.	Remove foreign object.
	Gear noise	Replace motor assembly.
Coasting.	Defective brake.	Replace motor assembly.
Roller displaced from mounting bracket.	Pin end slipped out of nylon bearing	Remove pin end mounting. Realign motor in tube. Reattach pin end.
Fabric hangs crooked.	Screen not installed properly..	Check for level and plumb.
	Fabric has backed up inside case.	Adjust "down" limit switch slowly until roller is exposed and wrinkle comes out, then readjust for proper drop.
	Fabric is damaged.	Replace fabric.

LIMITED ONE YEAR WARRANTY ON DA-LITE PRESENTATION PRODUCTS

Milestone AV Technologies LLC warrants certain Da-Lite branded products to the original purchaser only, to be free from defects in materials and workmanship for a period of one (1) year from the date of purchase by the original purchaser; provided they are properly operated according to Da-Lite's instructions and are not damaged due to improper handling or treatment after shipment from the factory.

This warranty does not apply to equipment showing evidence of misuse, abuse or accidental damage, or which has been tampered with or repaired by a person other than authorized Da-Lite personnel.

Da-Lite's sole obligation under this warranty shall be to repair or to replace (at Da-Lite's option) the defective part of the merchandise. Returns for service should be made to your Da-Lite dealer. If it is necessary for the dealer to return the screen or part to Da-Lite, transportation expenses to and from Da-Lite are payable by the purchaser and Da-Lite is not responsible for damage in shipment. To protect yourself against damage or loss in transit, insure the product and prepay all transportation expenses.

TO THE MAXIMUM EXTENT PERMITTED BY APPLICABLE LAW, THIS WARRANTY IS IN LIEU OF ALL OTHER WARRANTIES, EXPRESS OR IMPLIED, INCLUDING WARRANTIES AS TO FITNESS FOR USE AND MERCHANTABILITY. Any implied warranties of fitness for use, or merchantability, that may be mandated by statute or rule of law are limited to the one (1) year warranty period. This warranty gives you specific legal rights, and you may also have other rights, which vary from state-to-state. **TO THE MAXIMUM EXTENT PERMITTED BY APPLICABLE LAW, NO LIABILITY IS ASSUMED FOR EXPENSES OR DAMAGES RESULTING FROM INTERRUPTION IN OPERATION OF EQUIPMENT, OR FOR INCIDENTAL, DIRECT, OR CONSEQUENTIAL DAMAGES OF ANY NATURE.**

In the event that there is a defect in materials or workmanship of a Da-Lite product, you may contact our Sales Partners at PO Box 137, Warsaw, IN 46581-0137, (574) 267-8101, (800) 622-3737.

IMPORTANT: THIS WARRANTY SHALL NOT BE VALID AND DA-LITE BRANDED PRODUCTS SHALL NOT BE BOUND BY THIS WARRANTY IF THE PRODUCT IS NOT OPERATED IN ACCORDANCE WITH THE DA-LITE WRITTEN INSTRUCTIONS.

Keep your sales receipt to prove the date of purchase and your original ownership.



A Milestone AV Technologies Brand

3100 North Detroit Street
Warsaw, Indiana 46582
P: 574.267.8101 or 800.622.3737
F: 574.267.7804 or 877.325.4832
E: info@da-lite.com
www.da-lite.com

DL-0174 11.13

© 2013 Milestone AV Technologies LLC. Printed in U.S.A.

81654