

# Panasonic®

## Operating Instructions

Studio Handy Camera

Model No. **AK-HC3800G/GS**

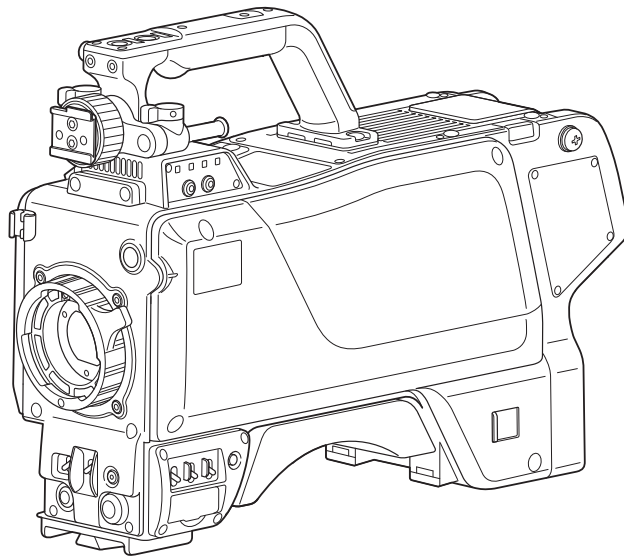

**DEUTSCH**

Für Erläuterungen in Deutsch, konsultieren Sie bitte die mitgelieferte CD-ROM.  
(→ Seite 5)

**FRANÇAIS**

Pour des explications en français, veuillez vous reporter au CD-ROM fourni.  
(→ page 5)

**ITALIANO**

Per le istruzioni in italiano, vedere il CD-ROM in dotazione. (→ pagina 5)

**ESPAÑOL**

Para la explicación en español, consulte el CD-ROM suministrado. (→ página 5)

**日本語**



日本語版の取扱説明書は付属のCD-ROMに納められています。(→5ページ)

This manual is also contained as a PDF file on the CD-ROM supplied with the unit. (→ page 5)



Before operating this product, please read the instructions carefully and save this manual for future use.

# Read this first!

	<b>CAUTION</b> <b>RISK OF ELECTRIC SHOCK</b> <b>DO NOT OPEN</b>	
<b>CAUTION: TO REDUCE THE RISK OF ELECTRIC SHOCK, DO NOT REMOVE COVER (OR BACK). NO USER SERVICEABLE PARTS INSIDE. REFER TO SERVICING TO QUALIFIED SERVICE PERSONNEL.</b>		

 The lightning flash with arrowhead symbol, within an equilateral triangle, is intended to alert the user to the presence of uninsulated “dangerous voltage” within the product’s enclosure that may be of sufficient magnitude to constitute a risk of electric shock to persons.

 The exclamation point within an equilateral triangle is intended to alert the user to the presence of important operating and maintenance (servicing) instructions in the literature accompanying the appliance.

## WARNING:

This equipment must be earthed.  
To ensure safe operation, make sure that the optical cable is securely connected to an earthed CCU when in use.  
The fact that the equipment operates satisfactorily does not imply that the power point is earthed or that the installation is completely safe. For your safety, if you are in any doubt about the effective earthing of the power point, please consult a qualified electrician.

## WARNING:

- To reduce the risk of fire or electric shock, do not expose this equipment to rain or moisture.
- To reduce the risk of fire or electric shock, keep this equipment away from all liquids. Use and store only in locations which are not exposed to the risk of dripping or splashing liquids, and do not place any liquid containers on top of the equipment.

## WARNING:

Always keep memory cards (optional accessory) or accessories (camera number sheet) out of the reach of babies and small children.

## CAUTION:

Do not remove panel covers by unscrewing.  
To reduce the risk of electric shock, do not remove the covers. No user serviceable parts inside.  
Refer servicing to qualified service personnel.

## CAUTION:

In order to maintain adequate ventilation, do not install or place this unit in a bookcase, built-in cabinet or any other confined space. To prevent risk of electric shock or fire hazard due to overheating, ensure that curtains and any other materials do not obstruct the ventilation.

## CAUTION:

The optical cable shall remain readily operable.  
To completely disconnect this equipment from the power supply, disconnect the optical cable from the equipment.

## CAUTION:

To reduce the risk of fire or electric shock and annoying interference, use the recommended accessories only.

## CAUTION:

Excessive sound pressure from earphones and headphones can cause hearing loss.

## CAUTION:

Invisible Laser radiation is emitted from the Optical fiber connector when this product is turned on.  
Don’t look into directly into the Optical fiber connector of this product.

## CAUTION:

Do not jar, swing, or shake the unit by its handle while another accessory is attached.  
Due to the added weight, any strong jolt to the handle may damage the unit or result in personal injury.

## CAUTION:

Do not lift the unit by its handle while the tripod is attached. When the tripod is attached, its weight will also affect the unit’s handle, possibly causing the handle to break and hurting the user. To carry the unit while the tripod is attached, take hold of the tripod.

## CAUTION:

Do not leave the unit in direct contact with the skin for long periods of time when in use.  
Low temperature burn injuries may be suffered if the high temperature parts of this unit are in direct contact with the skin for long periods of time.  
When using the equipment for long periods of time, make use of the tripod.

## CAUTION:

This product uses a semiconductor laser system and is a laser class 1 product complies with Radiation Performance Standards, 21CFR SUBCHAPTER J.  
Use of controls or adjustments or performance of procedures other than those specified herein may result in hazardous radiation exposure.  
Don’t make any modifications.  
Don’t repair by yourself.  
Refer servicing to qualified personnel.

 indicates safety information.

### FCC NOTICE(USA)

This device complies with part 15 of the FCC Rules. Operation is subject to the following two conditions:

(1) This device may not cause harmful interference, and (2) this device must accept any interference received, including interference that may cause undesired operation

#### CAUTION:

This equipment has been tested and found to comply with the limits for a class A digital device, pursuant to Part 15 of the FCC Rules.

These limits are designed to provide reasonable protection against harmful interference when the equipment is operated in a commercial environment. This equipment generates, uses, and can radiate radio frequency energy and, if not installed and used in accordance with the instruction manual, may cause harmful interference to radio communications.

Operation of this equipment in a residential area is likely to cause harmful interference in which case the user will be required to correct the interference at his own expense.

#### FCC Warning:

To assure continued FCC emission limit compliance, follow the attached installation instructions and the user must use only shielded interface cables when connecting to host computer or peripheral devices.

Also, any unauthorized changes or modifications to this equipment could void the user's authority to operate this device.

### NOTIFICATION(Canada)

This class A digital apparatus complies with Canadian ICES-003.

 indicates safety information.

**EEE Yönetmeliğine Uygundur.**  
**EEE Complies with Directive of Turkey.**



Importer's name and address of pursuant to EU rules:  
**Panasonic Testing Centre**  
**Panasonic Marketing Europe GmbH**  
Winsbergring 15, 22525 Hamburg, Germany

## EMC NOTICE FOR THE PURCHASER/USER OF THE APPARATUS

### 1. Applicable standards and operating environment (AK-HC3800)

The apparatus is compliant with:

- standards EN55103-1 and EN55103-2 2009, and
- electromagnetic environments E1 - E5.

### 2. Pre-requisite conditions to achieving compliance with the above standards

#### <1> Peripheral equipment to be connected to the apparatus and special connecting cables

- The purchaser/user is urged to use only equipment which has been recommended by us as peripheral equipment to be connected to the apparatus.
- The purchaser/user is urged to use only the connecting cables described below.

#### <2> For the connecting cables, use shielded cables which suit the intended purpose of the apparatus.

- Video signal connecting cables  
Use double shielded coaxial cables, which are designed for 75-ohm type high-frequency applications, for SDI (Serial Digital Interface). Coaxial cables, which are designed for 75-ohm type high-frequency applications, are recommended for analog video signals.
- Audio signal connecting cables  
If your apparatus supports AES/EBU serial digital audio signals, use cables designed for AES/EBU.  
Use shielded cables, which provide quality performance for high-frequency transmission applications, for analog audio signals.
- Other connecting cables  
Use shielded cables, which provide quality performance for high-frequency applications, as connecting cables.
- When connecting to the DVI signal terminal, use a cable with a ferrite core.
- If your apparatus is supplied with ferrite core(s), they must be attached on cable(s) following instructions in this manual.

### 3. Performance level

The performance level of the apparatus is equivalent to or better than the performance level required by these standards.

However, the apparatus may be adversely affected by interference if it is being used in an EMC environment, such as an area where strong electromagnetic fields are generated (by the presence of signal transmission towers, cellular phones, etc.). In order to minimize the adverse effects of the interference on the apparatus in cases like this, it is recommended that the following steps be taken with the apparatus being affected and with its operating environment:

1. Place the apparatus at a distance from the source of the interference.
2. Change the direction of the apparatus.
3. Change the connection method used for the apparatus.
4. Connect the apparatus to another power outlet where the power is not shared by any other appliances.

### Декларація про Відповідність

Вимогам Технічного Регламенту Обмеження Використання деяких Небезпечних Речовин в електричному та електронному обладнанні (затвердженого Постановою №1057 Кабінету Міністрів України)

Виріб відповідає вимогам Технічного Регламенту Обмеження Використання деяких Небезпечних Речовин в електричному та електронному обладнанні (ТР ОБНР).

Вміст небезпечних речовин у випадках, не обумовлених в Додатку №2 ТР ОБНР, :

1. свинець(Pb) – не перевищує 0,1 % ваги речовини або в концентрації до 1000 частин на мільйон;
2. кадмій (Cd) – не перевищує 0,01 % ваги речовини або в концентрації до 100 частин на мільйон;
3. ртуть(Hg) – не перевищує 0,1 % ваги речовини або в концентрації до 1000 частин на мільйон;
4. шестивалентний хром (Cr6+ ) – не перевищує 0,1 % ваги речовини або в концентрації до 1000 частин на мільйон;
5. полібромбіфеніли (PBB) – не перевищує 0,1% ваги речовини або в концентрації до 1000 частин на мільйон;
6. полібромдефенілові ефіри (PBDE) – не перевищує 0,1 % ваги речовини або в концентрації до 1000 частин на мільйон.

## IMPORTANT SAFETY INSTRUCTIONS

- 1) Read these instructions.
- 2) Keep these instructions.
- 3) Heed all warnings.
- 4) Follow all instructions.
- 5) Do not use this apparatus near water.
- 6) Clean only with dry cloth.
- 7) Do not block any ventilation openings. Install in accordance with the manufacturer's instructions.
- 8) Do not install near any heat sources such as radiators, heat registers, stoves, or other apparatus (including amplifiers) that produce heat.
- 9) Do not defeat the safety purpose of the polarized or grounding-type plug. A polarized plug has two blades with one wider than the other. A grounding-type plug has two blades and a third grounding prong. The wide blade or the third prong are provided for your safety. If the provided plug does not fit into your outlet, consult an electrician for replacement of the obsolete outlet.
- 10) Protect the power cable from being walked on or pinched particularly at plugs, convenience receptacles, and the point where they exit from the apparatus.
- 11) Only use attachments/accessories specified by the manufacturer.
- 12) Use only with the cart, stand, tripod, bracket, or table specified by the manufacturer, or sold with the apparatus. When a cart is used, use caution when moving the cart/apparatus combination to avoid injury from tip-over.
- 13) Unplug this apparatus during lightning storms or when unused for long periods of time.
- 14) Refer all servicing to qualified service personnel. Servicing is required when the apparatus has been damaged in any way, such as power-supply cord or plug is damaged, liquid has been spilled or objects have fallen into the apparatus, the apparatus has been exposed to rain or moisture, does not operate normally, or has been dropped.



S3125A

## ENGLISH

### ■ How to open the operating instruction manual PDF files

Discontinue installation if the installation screen of the software opens as a result of inserting the CD-ROM.

When [INDEX.pdf] on the CD-ROM is opened, a list of the operating instruction manuals will be displayed.

Click on the document name of the manual to be opened.

- **Adobe® Reader® is required to read PDF files.**  
It can be downloaded from the home page of Adobe Systems.

## DEUTSCH

### ■ Öffnen der PDF-Dateien der Bedienungsanleitung

Brechen Sie die Installation ab, falls beim Einlegen der CD-ROM der Installationsbildschirm der Software erscheint.

Wenn [INDEX.pdf] auf der CD-ROM geöffnet wird, erscheint eine Liste der Bedienungsanleitungen.

Klicken Sie auf den Dokumentennamen der zu öffnenden Anleitung.

- **Zum Lesen der PDF-Dateien benötigen Sie Adobe® Reader®.**  
Dieses Programm kann von der Homepage von Adobe Systems heruntergeladen werden.

## FRANÇAIS

### ■ Comment ouvrir les fichiers PDF des manuels du mode d'emploi

Arrêter l'installation si l'écran d'installation du logiciel s'ouvre quand le CD-ROM est inséré.

Quand [INDEX.pdf] sur le CD-ROM s'ouvre, la liste des manuels du mode d'emploi s'affiche.

Cliquer sur le nom du document correspondant au manuel à consulter.

- **Adobe® Reader® est nécessaire pour lire les fichiers PDF.**  
Ce logiciel peut être téléchargé depuis la page d'accueil d'Adobe Systems.

## ITALIANO

### ■ Come aprire i file dei manuali di istruzioni per l'uso

Se inserendo il CD-ROM si apre la schermata di installazione del software, interrompere l'installazione.

Aperto [INDEX.pdf] sul CD-ROM, viene visualizzato un elenco di manuali di istruzioni per l'uso.

Fare clic sul nome del documento corrispondente al manuale da aprire.

- **Per leggere i file PDF è necessario Adobe® Reader®.**  
Il programma può essere scaricato dal sito Web di Adobe Systems.

## ESPAÑOL

### ■ Modo de abrir los archivos PDF que contienen el manual de las instrucciones de funcionamiento

Interrumpa la instalación si la pantalla de instalación del software se abre como resultado de insertar el CD-ROM.

Cuando se abra [INDEX.pdf] en el CD-ROM se visualizará una lista de los manuales de instrucciones de funcionamiento.

Haga clic en el nombre de documento del manual que va a abrir.

- **Para leer los archivos PDF se necesita el programa Adobe® Reader®.**  
Este programa se puede descargar de la página inicial de Adobe Systems.

## 日本語

### ■ 取扱説明書PDFファイルの聞き方

CD-ROMを挿入してソフトウェアのインストール画面が立ち上がる場合は、インストールを中止してください。

CD-ROM内の[INDEX.pdf]を聞くと取扱説明書の一覧が表示されません。

開きたい取扱説明書のドキュメント名をクリックしてください。

- **PDFファイルをご覧いただくには、Adobe® Reader® が必要です。**  
アドビシステムズ社のホームページからダウンロードしてください。

# Contents

Read this first! .....	2	Status displays on viewfinder screen .....	18
Introduction.....	6	Checking the operating time .....	20
Accessories .....	6	Warning displays.....	20
Features.....	7	Menu operations.....	21
Frame frequency setting.....	7	Menu configuration .....	23
Precautions for use.....	8	Table of the adjustment setting ranges.....	25
Parts and their functions .....	9	Data handled in the camera.....	31
Attaching/detaching the viewfinder .....	14	Updating the firmware in this unit .....	32
Connecting a microphone .....	15	Dimensional outline drawing.....	32
Component system configuration .....	16	Specifications .....	33
AK-HC3800G/GS Connector Pins .....	17	Index .....	34

## Introduction

### Request

This unit is shipped with the frame frequency set to 59.94 Hz. Follow the procedure on page 7 to change the frame frequency to match the region of use.

This unit is a studio handy camera that supports the 1080i format. Combined use with Panasonic's peripheral equipment Camera Control Unit AK-HCU200/S and Remote Operation Panel AK-HRP200G enables you to build an optical transmission studio camera system with high image quality capable of uncompressed long-distance transmission at a low cost.

It uses a 2/3-type 2.2-megapixel IT-CCD imaging device in conjunction with a newly-developed 16-bit A/D digital signal processing circuit to achieve higher sensitivity than conventional cameras. Furthermore, it includes new functions such as CAC (chromatic aberration compensation function to compensate the chromatic aberration of the magnification of a lens) and scan reverse (a function to compensate the reverse video when using an anamorphic lens and film lens), in addition to multi-functionality, high quality, and improved stable operability that can be achieved only by digital processing.

#### ■ About trademarks and registered trademarks

- Adobe® and Reader® are either registered trademarks or trademarks of Adobe Systems Incorporated in the United States and other countries.
- SDHC logo is a trademark of SD-3C, LLC.
- Company names, product names, and other names appearing in this manual are trademarks or registered trademarks of their respective companies.

#### ■ Illustrations and screen images in this manual

Illustrations of the camera unit and menu screens may appear different from the actual camera unit and menu screens.

#### ■ Reference pages

Reference pages are indicated as (page 00) in this manual.



#### ■ Terms

- "Memory card" is used to indicate both SD memory card and SDHC memory card.
- "CCU" is used to indicate camera control unit in this manual.
- "ROP" is used to indicate remote operation panel in this manual.

## Accessories

Please check the accessories.

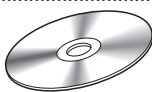
- Dispose of the package appropriately after unpacking the product.

CD-ROM..... 1  • Operating Instructions	Camera number sheet (1 to 12) ..... 1 set 	Lens mount cap..... 1 (Already mounted to the main body) 
--	--	--

# Features

## 1080i, 2.2-megapixel CCDs employed

- The standard sensitivity is F11 (F12 with 50 Hz). High sensitivity is also achieved.  
Furthermore, it can operate at 1080i (50 Hz/59.94 Hz switchable).

## Digital signal processing with a 16-bit A/D converter

- A 16-bit A/D converter with a sampling frequency of 74 MHz converts the video signals into digital signals to reproduce fine and high quality images.

## Chromatic Aberration Compensation (CAC) function

- This unit is equipped with a function to compensate the chromatic aberration of the magnification of a lens caused by the fact that the refractive index of a lens varies with the wavelength of light (hereinafter referred to as the chromatic aberration).  
The chromatic aberration of the magnification is caused by the differences in the red (R), green (G), and blue (B) refractive indexes of a lens. The lens itself corrects chromatic aberration but it remains, in particular, in the surrounding area. Furthermore, the zooming ratio, iris, and focal distance have a complicated relationship with this chromatic aberration in the case of a zoom lens. Images have registration errors.

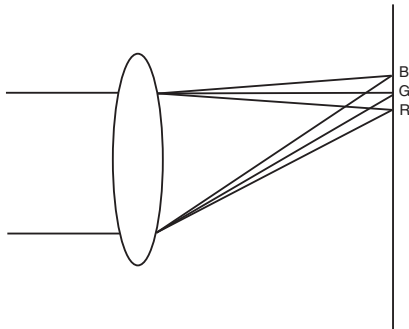

Using this function enables the chromatic aberration around the lens to be compensated and high quality video signals to be obtained. However, a lens supporting chromatic aberration compensation must be used.

## Digital extender function

- This function extends the image to twice its original size in the digital signal processing circuit. It enables shooting at a higher magnification. This function can be assigned to the assignable switches <USER 1, 2, and 3> and the external return control switches 1, 2, and 3.

## Film-like gamma function

- In order to facilitate obtaining film tone in VariCam (AJ-HDC27 series), this unit is equipped with FILM-REC gamma that is almost equivalent to VariCam.

## DRS (Dynamic Range Stretcher) function

- With this function, the dynamic range can be extended by compressing video signal levels in a high-brightness area while maintaining contrast to prevent blown out highlights that may occur in normal shooting situations.

## Optical digital transmission

- High-quality uncompressed digital transmission is made possible by connecting this unit to a camera control unit (CCU) with an optical fiber multi cable. Furthermore, prompter and return signals input into the CCU can be output from the camera.

# Frame frequency setting

This unit is shipped with the frame frequency set to 59.94 Hz.

Before using this unit, follow the procedure below to change the setting to the frame frequency to be used.

1. Connect the viewfinder to this unit (→ page 14), or connect the camera HD-SDI output2 connector <HD-SDI2> to the monitor (→ page 11)

### <Note>

For the details on the CCU settings, refer to the Operating Instructions for the CCU.

2. Connect the optical fiber multi cable or DC power supply to this unit.

For details on the menu operations, refer to page 21.

3. Turn on the power, and then press the menu switch <MENU>.

The [USER MENU] screen appears.

4. Turn the <SELECT> JOG dial button to move the cursor (arrow) to the [MAINTENANCE] item, and then press the <SELECT> JOG dial button.

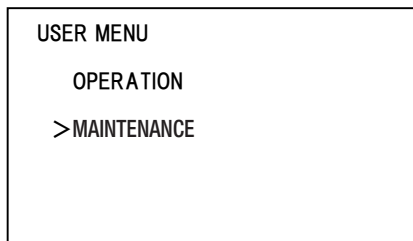

5. Turn the <SELECT> JOG dial button to move the cursor (arrow) to the [SYSTEM] item, and then press the <SELECT> JOG dial button.

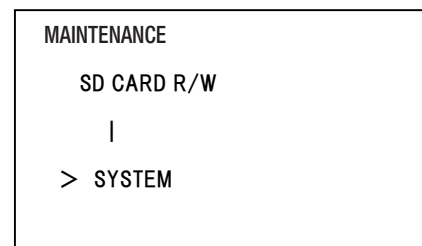

6. Turn the <SELECT> JOG dial button to move the cursor (arrow) to the [FORMAT] item, and then press the <SELECT> JOG dial button.

7. Select [59.94i] or [50i] with the cursor (arrow), and then press the <SELECT> JOG dial button.

The frame frequency setting is confirmed.

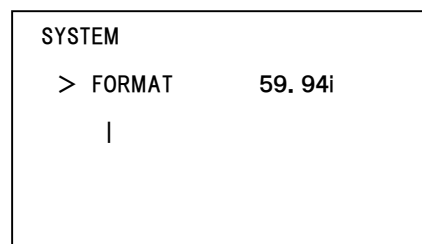

8. Turn the power of this unit off and then back on.

# Precautions for use

## DON'TS

- Do not attempt to disassemble the camera or other units. In order to prevent electric shock, do not remove screws or covers. There are no user-serviceable parts inside.
- Do not abuse the camera. Avoid striking, shaking, etc. The camera contains sensitive components which could be damaged by improper handling or storage.
- Do not let the lens remain uncapped when the camera is not use. If the lens is not installed, do not leave the lens mount hole uncovered.
- Do not touch the surface of the lens or prism.
- Do not use strong or abrasive detergents when cleaning the camera body.
- Do not point the camera directly at the sun or a laser beam no matter whether it is turned on or not. Taking images of the sun, laser beams, or other brightly lit subjects for prolonged periods of time may damage the CCD.
- Do not operate the camera outdoors during a lightning storm.
- Do not use the camera in an extreme environment where high temperatures or high humidity exist.
- Do not leave the camera turned on when not in use. Do not unnecessarily turn the camera power on and off repeatedly. Do not block the ventilation slots.
- Do not cover the port otherwise block ventilation during operation. Internal heat buildup can cause a fire.

## DO'S

- Connecting to a CCU  
Connect this unit to a designated CCU that is properly grounded.
- Refer any servicing to qualified service personnel.
- Handle the camera with care.
- Protect the precision made lens by placing the lens cap over when the camera is not in use. If the lens is not installed, protect the surface of the prism by placing the body cap into the lens mount hole.
- Use a mild blower or lens cleaning tissue designed for coated lenses, to clean the surface of the lens or prism in the event that it should become dirty.

- Use a dry cloth to clean the camera if it is dirty. In case the dirt is hard to remove, use mild detergent and wipe gently.
- Optical fiber connector  
The transmission and reception conditions of optical signals will deteriorate when the optical fiber connector has become dirty so be sure to clean the connector. (→ page 10)
- Use caution when operating the camera in the vicinity of spot lights or bright lights, as well as light reflecting objects and surfaces.
- Take immediate action if ever the camera should become wet. Turn the power off and have the unit checked by an authorized service facility.
- Follow normal safety precaution to avoid personal injury.
- Avoid using this unit in a cold place where the temperature drops below -10 °C (14°F) or in a hot place where the temperature rises above 45 °C (113°F) because image quality will deteriorate and the internal components will be adversely affected. Preheating is required in a low-temperature environment. Confirm that the WARM UP warning display (→ page 20) is not displayed before use.
- Always turn the power off when the camera is not going to be used. Operate the camera only when there is adequate ventilation.
- Cooling fan  
There is internally provided a cooling fan.  
Since the cooling fan is a consumable part, replace it after about 50,000 hours of operation.  
(Be sure to ask the dealer for the replacement.)
- When using the unit in windy or snowy conditions or at the beach or at the waterfront, cover it with the rain cover (optional accessory) or protect it in some other way in order to prevent it from getting wet and stop water from seeping inside.
- Use the camera in places with minimal moisture and dust. Avoid using the camera in places with high concentrations of moisture or dust since these conditions will tend to cause damage to the internal parts. In addition, ensure that the connectors which are not in use are covered with their protective caps.
- Peripheral equipment software  
The versions of the software of the peripheral equipment (CCU and ROP) to be connected to the AK-HC3800G/GS may need to be updated.  
For further details, contact your dealer.

## Regarding the Protection of Personal Information

削除します

Images of clearly identifiable individuals that are recorded using this unit are subject to the Act on the Protection of Personal Information.\*

Be sure to handle image information in accordance with the law.

\* Please refer to "Cases corresponding to personal information" in the "Guidelines Targeting Economic and Industrial Sectors Pertaining to the Act on the Protection of Personal Information" published by the Ministry of Economy, Trade and Industry.

- Images recorded by this product and stored on the SD memory cards it uses may be classified as personal information. Make sure that such information is handled appropriately such as when this product is disposed of, transferred, handed in for repair or otherwise comes into the hands of a third person. Remove the SD memory card and store it in a safe place.



## Parts and their functions

---

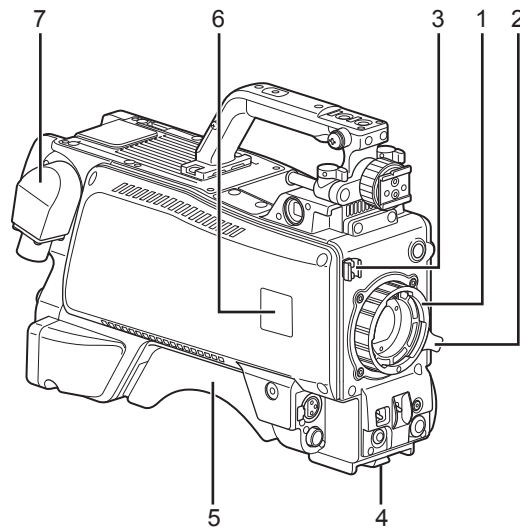

### 1. Lens mount (Bayonet type)

Mount the lens here.

### 2. Lens clamp lever

Insert the lens into the lens mount (1), and then turn this lever to clamp the lens in place.

### 3. Lens cable/microphone cable clamps

Use these to clamp the lens cable and microphone cable in place.

### 4. Tripod mount

Before securing the Studio Handy Camera to a tripod, attach the tripod attachment (SHAN-TM700) which is available as an optional accessory.

### 5. Shoulder pad

Use this when the Studio Handy Camera is to be carried on the shoulder. This reduces the burden on the shoulder when carrying this unit on the shoulder.

### 6. Camera number sheet holder

This enables the accessory camera number sheet to be attached.

### 7. Optical fiber connector <OPT FIBER>\*1

Use this to connect the CCU (camera control unit) with an optical fiber multi cable. When it is not in use, cover it with its dust cap.

\*1 AK-HC3800G: OPS2402-R (TAJIMI ELECTRONICS)  
AK-HC3800GS: EDW.3K.93C.TLC (LEMO)

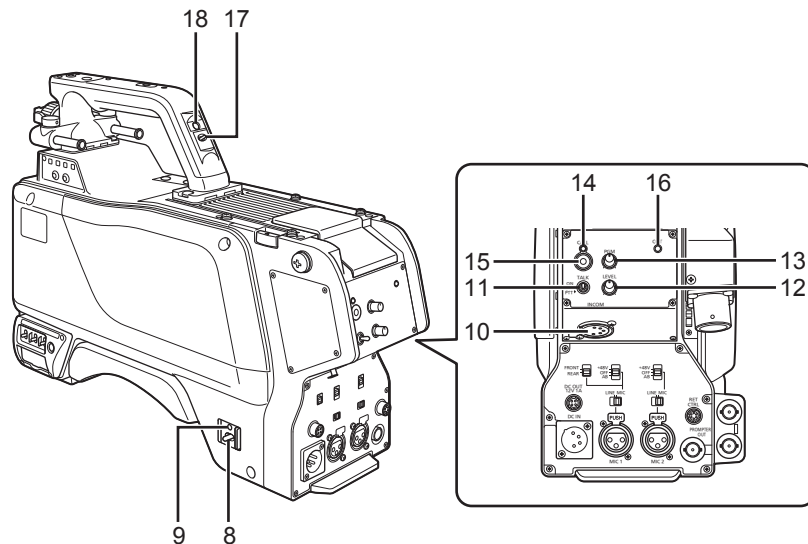

### 8. Camera power switch <POWER>

Use this to select the camera power input (power supplied from the CCU or from an external power supply input connector <DC IN>) and turn the power OFF.

- CCU : When connecting this unit to the CCU, supply power from the CCU and turn the power ON.
- EXT : When connecting the external DC power supply to this unit, supply power from the external power supply and turn the power ON.
- Middle position : Turn the power OFF.

### 9. Power LED

This lights up green when power is supplied to the camera.

- Green light ON : The camera power is ON
- Red light ON : The camera power is OFF while connected to the CCU whose power is ON
- Light OFF : The camera power is OFF while not connected to the CCU, or while connected to the CCU whose power is OFF

### 10. INCOM connector <INCOM>

Connect the intercom or headset plug here.

### 11. INCOM MIC ON/OFF switch <TALK>

This is the intercom microphone ON/OFF/PTT selector switch. When using the Push-to-Talk (PTT) intercom or headset, set the switch to the PTT side to turn on the microphone.

### 12. INCOM level control <LEVEL>

This is used to adjust the volume level of the intercom when the intercom and PGM mixing function is set to ON. The intercom and PGM mixing function can be set to ON or OFF on the camera menu.  
[USER MENU] > [OPERATION] > [MIC/INCOM SETTING] > [PGM MIX]

### 13. INCOM/PGM level control <PGM>

This is used to adjust the intercom and PGM mixing level.

### 14. CALL LED

This lights up green when the CALL switch is pressed from the ROP or CCU.

### 15. CALL switch <CALL>

While this switch is pressed, the CALL LEDs on the ROP and CCU are lit and the buzzer on the ROP sounds. (When the buzzer setting of the ROP is ON)

### 16. OPT LED

This indicates the camera's optical signal reception status.

- Normal : Green light ON
- Error : Red light ON

#### <Note>

When an error occurs, turn off the power of this unit and the CCU and then clean the optical fiber connector. If the error is not cleared, immediately turn off the power, and contact your dealer.

### 17. Back tally LED selector switch

Use this to set the back tally LED to ON or OFF.

### 18. Back tally LED

This lights when the tally signal is supplied.

- R tally signal: Red light ON
- G tally signal: Green light ON
- R and G tally signals at the same time: Red light ON

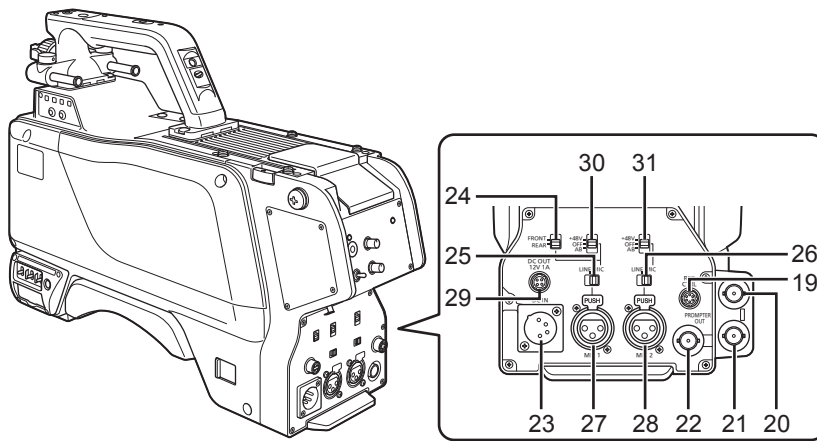

**19.RET switching control connector <RET CTRL>**

Connect the cable of the RET switching box here to control the ON/OFF of RET 1, 2, and 3 and intercom microphone.

For RET 1, 2, and 3, you can select any of the Return A, Return B, and Digital extender on the camera menu to assign it.  
 [USER MENU] > [OPERATION] > [SWITCH MODE] > [EXTERNAL RETURN1] ([EXTERNAL RETURN2], [EXTERNAL RETURN3])

- RET A : RET A image switching function is assigned
- RET B : RET B image switching function is assigned
- D.EXT : Digital extender switching function is assigned

**20.Camera HD-SDI output1 connector (BNC) <HD-SDI1>**

The camera HD-SDI images are output from this connector.

**<Note>**

Use a 5C-FB or equivalent cable when outputting the HD-SDI signals.

**21.Camera HD-SDI output2 connector (BNC) <HD-SDI2>**

Camera images, VF images or RET images can be selected on the camera menu to output HD-SDI signals from this connector.

[USER MENU] > [OPERATION] > [SETTING] > [HD-SDI2 OUT]

- MAIN : Outputs camera images from HD-SDI2
- VF : Outputs VF images from HD-SDI2
- RET : Outputs return images from HD-SDI2

**<Note>**

Use a 5C-FB or equivalent cable when outputting the HD-SDI signals.

**22.PROMPT output connector <PROMPTER OUT>**

The prompter video input from the CCU is output from this connector.

**23.External power supply input connector <DC IN>**

Connect the input of the external DC power supply to this connector. (10.8 V to 17 V DC)

**<Note>**

- Inrush current occurs when the power of this unit is turned on. Insufficient power supply capacity at power on may cause a failure. It is recommended to use an external DC power supply with a capacity that is at least double the total power consumption of this unit and components (viewfinder, etc.) whose power is turned on when the power of this unit is turned on. For the DC cable, use a 2-core shielded cable with a core cross section equivalent to or larger than AGW18 (nominal cross section 0.824 mm<sup>2</sup>).
- When using the external DC power supply, be sure to turn ON the camera power switch <POWER> of the external DC power supply and then turn ON the camera power switch <POWER> of this unit. If you turn on the power in reverse sequence, the output voltage of the external DC power supply rises slowly so this unit may malfunction.
- Check the pin assignment of the DC output terminal on the external DC power supply and the pin assignment of the <DC IN> terminal on this unit, and connect the terminals with the correct polarity. (→ page 17)  
 Incorrect connection of the 12 V power supply terminal to the GND terminal may cause a fire or failure.
- Operation from the CCU and ROP while using an external DC power supply is also possible when this unit and the CCU are connected, but operation is affected by the increase in distance between this unit and the CCU.

**24.MIC1 selector switch1 <FRONT/REAR>**

If the MIC1 selector switch2 is set to "MIC," use this to switch the MIC input signal to FRONT MIC or REAR MIC.

- FRONT : Switches to the FRONT MIC
- REAR : Switches to the REAR MIC

**25.MIC1 selector switch2 <LINE/MIC>**

Use this to switch the audio channel1 input signal to LINE or MIC.

- LINE : Switches to the LINE input
- MIC : Switches to the FRONT MIC or REAR MIC

**26.MIC2 selector switch <LINE/MIC>**

Use this switch to select LINE or MIC for the audio channel 2 input signals.

**27.Rear MIC1 connector <MIC1>**

Connect an audio device or microphone to this connector. The gain setting can be selected on the camera menu.

The power for the microphone is supplied from this connector, enabling use of a phantom or AB powered microphone. Turn the power off when connecting a microphone and then configure the settings to match the microphone after connecting the microphone.

**28.Rear MIC2 connector <MIC2>**

Connect an audio device or microphone to this connector. The gain setting can be selected on the camera menu.

The power for the microphone is supplied from this connector, enabling use of a phantom or AB powered microphone. Set the power for a microphone after connecting the microphone.

**29.DC output connector <DC OUT 12V 1A>**

12 V DC power (up to 1.0 A) can be supplied. If the current exceeds the rating, the power is turned off forcibly.

R and G tally signals are output. (Open collector type)

**30.MIC1 power selector switch <+48V/OFF/AB>**

Use this to select the type of power to be supplied to MIC1.

- +48V : Phantom 48 V
- OFF : Power is not supplied
- AB : AB 12 V

**31.MIC2 power selector switch <+48V/OFF/AB>**

Use this to select the type of power to be supplied to MIC2.

- +48V : Phantom 48 V
- OFF : Power is not supplied
- AB : AB 12 V

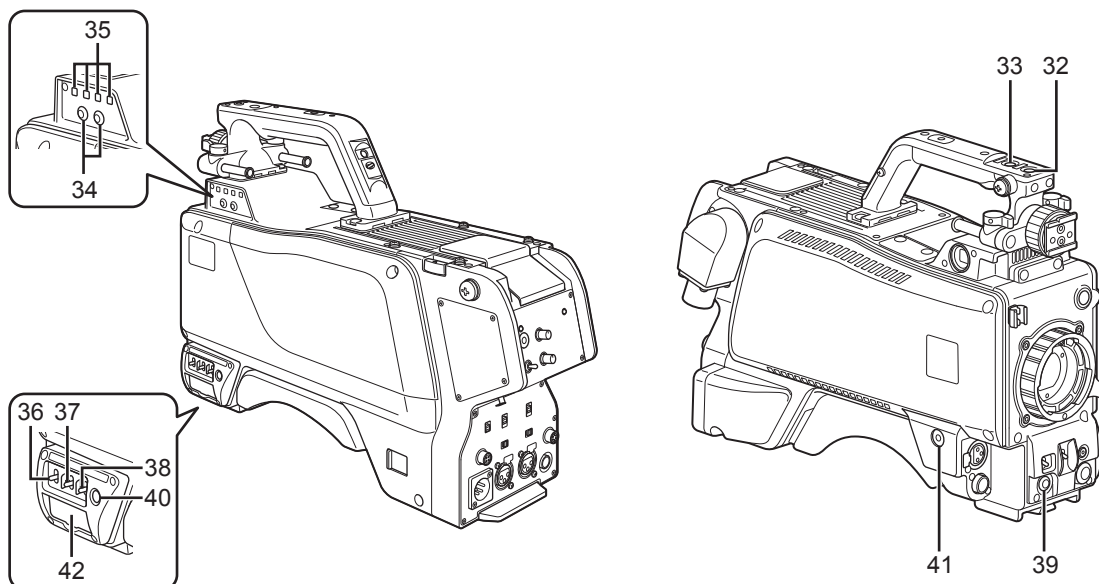

### 32. Grip PTT switch <PTT>

Use this to switch to Return A, Return B, or PTT in accordance with the setting.

This is set to PTT by factory default, and can be used to switch ON and OFF the intercom microphone. The function switching can be changed on the camera menu.

[USER MENU] > [OPERATION] > [SWITCH MODE] > [GRIP PTT]

- RET A : RET A image switching function is assigned
- RET B : RET B image switching function is assigned
- PTT : Function to turn on the intercom microphone only while the user is pressing the switch is assigned

### 33. Grip RET switch <RET>

Use this to switch to Return A, Return B, or PTT in accordance with the setting.

It is set to Return A by factory default, and can be used to switch to Return A. The function switching can be changed on the camera menu.

[USER MENU] > [OPERATION] > [SWITCH MODE] > [GRIP RET]

- RET A : RET A image switching function is assigned
- RET B : RET B image switching function is assigned
- PTT : Function to turn on the intercom microphone only while the user is pressing the switch is assigned

### 34. ND filter selector switch <ND FILTER>

Pressing the [<|/>] buttons switches between the optical filters.

[<]: CLEAR → 1/64 → 1/16 → 1/4 → CLEAR →...

[>]: CLEAR → 1/4 → 1/16 → 1/64 → CLEAR →...

### 35. ND filter selector LED

The LED for the selected optical filter number lights up.

- 1: CLEAR
- 2: 1/4
- 3: 1/16
- 4: 1/64

### 36. Gain selector switch <GAIN>

Use this to select the gain for the camera images. (LOW, MID or HIGH)

The gain setting can be selected from the CCU.

It cannot be used when the CCU is connected to this unit.

### 37. Camera output selector switch <OUTPUT>

Use this to select the video output (CAM, BAR or TEST).

The gain function cannot be used when the CCU is connected to this unit.

### 38. White balance memory selector switch <W.BAL>

Use this to select the white balance memory. Data can be recorded to A or B. The factory settings are set when the switch is set to PRST.

It cannot be used when the CCU is connected to this unit.

### 39. 40. 41 Assignable switches <USER 1, 2, and 3>

ON/OFF function settings configured ahead of time can be assigned to these switches using the camera menu.

### 42. Memory card slot <SDHC>

Insert a memory card (optional accessory) here. For the recording items, refer to the "Table of the adjustment setting ranges" (→ pages 25 to 30).

The memory card is used for saving/reading the setting menus of this unit, reading CAC files, updating the software, etc.

### ● Memory cards that can be used in this unit

Insert a memory card complying with the SD or SDHC standard into this unit. Note that an SDXC memory card is not supported.

Memory cards with the following capacity can be used in this unit.

SD (8 MB to 2 GB)

SDHC (4 GB to 32 GB)

For the latest information not described in the Operating Instructions, refer to the following websites.

<http://pro-av.panasonic.net/>

### <Note>

Observe the following points when using and storing this unit.

- Avoid high temperature and humidity.
- Avoid water droplets.
- Avoid static electricity.

\* SD Logo is a trademark.

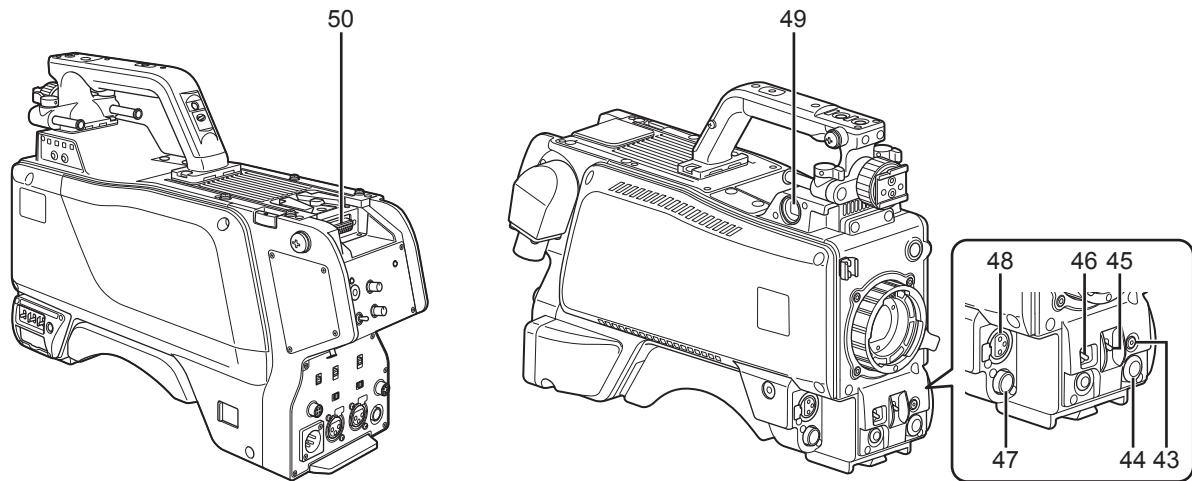

**43.Menu switch <MENU>**

When this switch is pressed, the camera's USER menu screen appears ([OPERATION]/[MAINTENANCE] menu).  
When it is pressed again, the menu screen display is cleared.

**44.JOG dial button <SELECT>**

Turning the JOG dial while the menu screen is displayed moves the cursor to the setting items. The menu settings can be confirmed with this dial button.  
For details on the menu operations, refer to the section on the menu operations (→ page 21).

**45.Electronic shutter selector switch <SHUTTER>**

Set this to ON when the electronic shutter is to be used. When it is set to the SEL position, the shutter speed is switched within the preset range.  
It cannot be used when the CCU is connected to this unit.

**46.AWB/ABB start switch <AUTO W/B BAL>**

Use this for making automatic white balance adjustments (AWB) or automatic black balance adjustments (ABB).  
It cannot be used when the CCU is connected to this unit.

**47.Lens connector <LENS>**

Connect the lens cable to this connector.

**48.Front MIC1 connector <MIC1(FRONT)>**

Connect a microphone (optional accessory) here. When using the microphone, set the MIC1 selector switch to FRONT.(→ page 15)  
The power for the microphone is supplied from this connector, enabling use of a phantom or AB powered microphone. Turn the power off when connecting a microphone and then configure the settings to match the microphone after connecting the microphone.

**49.Viewfinder connector <VF>**

Connect the color viewfinder (AJ-CVF100G) or 50.8 mm (2-inch) HD viewfinder (AJ-HVF21KG) cable to this connector.

**50.Rear viewfinder connector**

Connect the 17.8 cm (7-inch) LCD viewfinder (AK-HVF70G).  
Use this D-sub connector for the viewfinder interface.

## Attaching/detaching the viewfinder (The viewfinder is an optional accessory.)

### Attaching the viewfinder

An HD viewfinder can be used with this unit.  
Use the AJ-HVF21KG or AJ-CVF100G (optional accessory).  
For details on handling the viewfinder, refer to the operating instructions of the viewfinder.

1. Check that the camera's POWER switch is in the OFF position.
2. Pull up the knob on the mounting plate and slide the plate to attach the viewfinder.
3. Tighten the stopper screw securely.

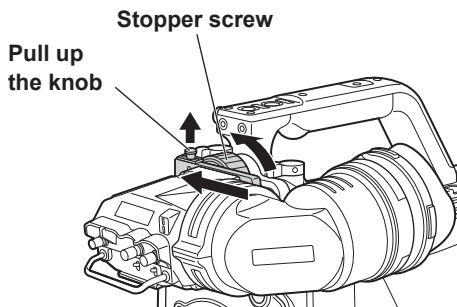

4. Connect the plug to the viewfinder connector <VF>.

#### <Note>

When connecting the plug to the viewfinder connector <VF>, check that the plug is inserted all the way into the connector.

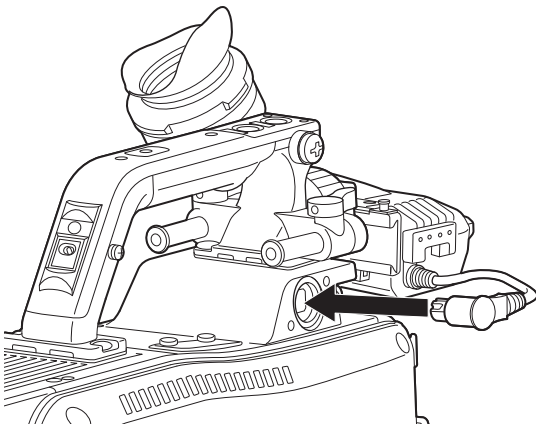

### Detaching the viewfinder

1. Check that the camera's POWER switch is in the OFF position.
2. Remove the plug from the viewfinder connector <VF>.
3. Loosen the stopper screw, pull up the knob on the mounting plate, and slide the viewfinder along and off the plate.

### Attaching the rear viewfinder

Use the AK-HVF70G rear viewfinder (optional accessory).  
For details on handling the LCD viewfinder, refer to the operating instructions of the LCD viewfinder.

1. Check that the camera's POWER switch is in the OFF position.
2. Check that the LCD viewfinder's PAN BRAKE knob and TILT LOCK dial are locked.  
For the operating procedures of the LCD viewfinder's PAN BRAKE knob and TILT LOCK dial, refer to the operating instructions of the LCD viewfinder.
3. Press the lock release button and detach the D-sub connector cover.

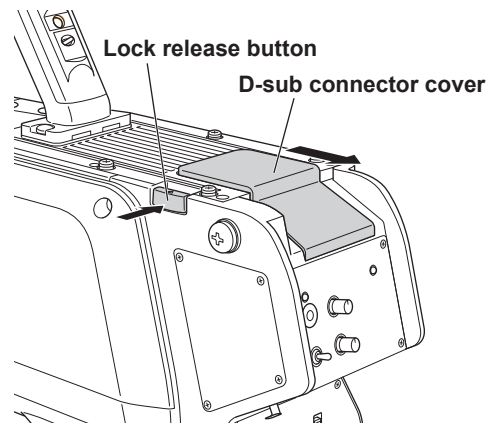

4. Align the V-shaped protrusion on the LCD viewfinder with the V-shaped groove on the camera, and slide and push it until the lock is engaged.

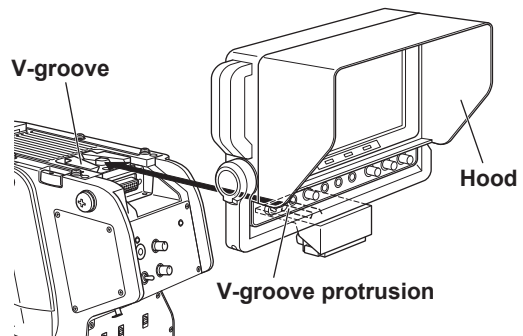

#### <Note>

When attaching a viewfinder, do not hold the hood of the viewfinder.

### Detaching the rear viewfinder

1. Check that the camera's POWER switch is in the OFF position.
2. Slide the LCD viewfinder while pressing the lock release button until it is detached  
<Note>  
When detaching a viewfinder, do not hold the hood of the viewfinder.
3. Attach the connector cover

# Connecting a microphone

## ■ When the microphone is mounted on the viewfinder (optional accessory) for use

A microphone such as the AJ-MC700 microphone kit (optional accessory) can be mounted on the viewfinder.

### 1. Open the microphone holder

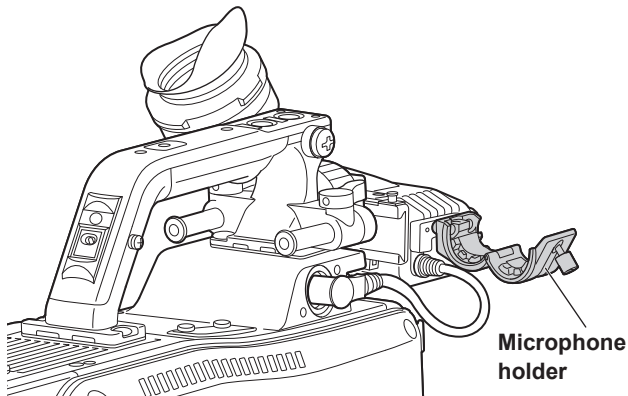

### 2. Mount the microphone and tighten the clamp screw

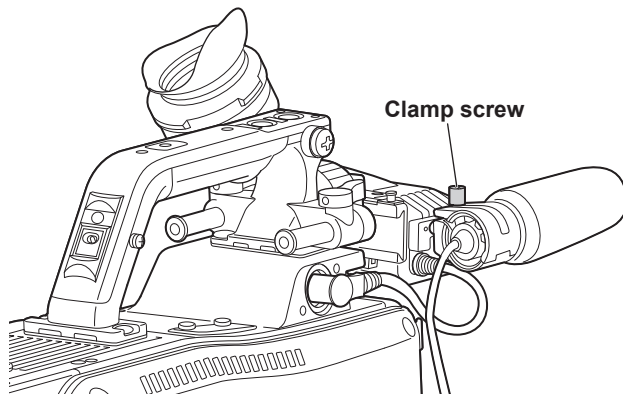

### 3. Pass the the microphone cable through the cable clamp, and connect it to the front MIC1 connector <MIC1> on the unit

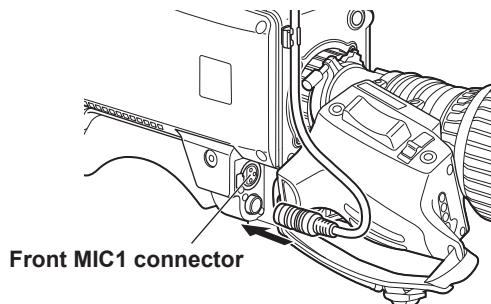

### 4. If front microphone audio is to be used, set the MIC1 selector switch 1 to FRONT MIC <FRONT> and the MIC1 selector switch 2 to <MIC>, and use the MIC1 power selector switch to set the power to match the microphone.

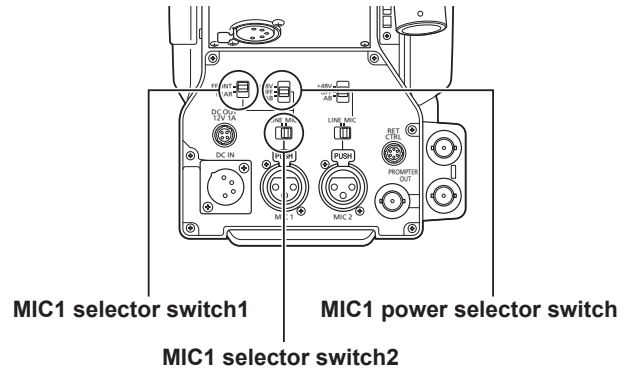

# Component system configuration

An example of the standard system consisting of the Studio Handy Camera (AK-HC3800G/GS) and peripheral components is shown below. The basic system configuration includes the lens, Studio Handy Camera, viewfinder, CCU, and ROP.

## System block diagram

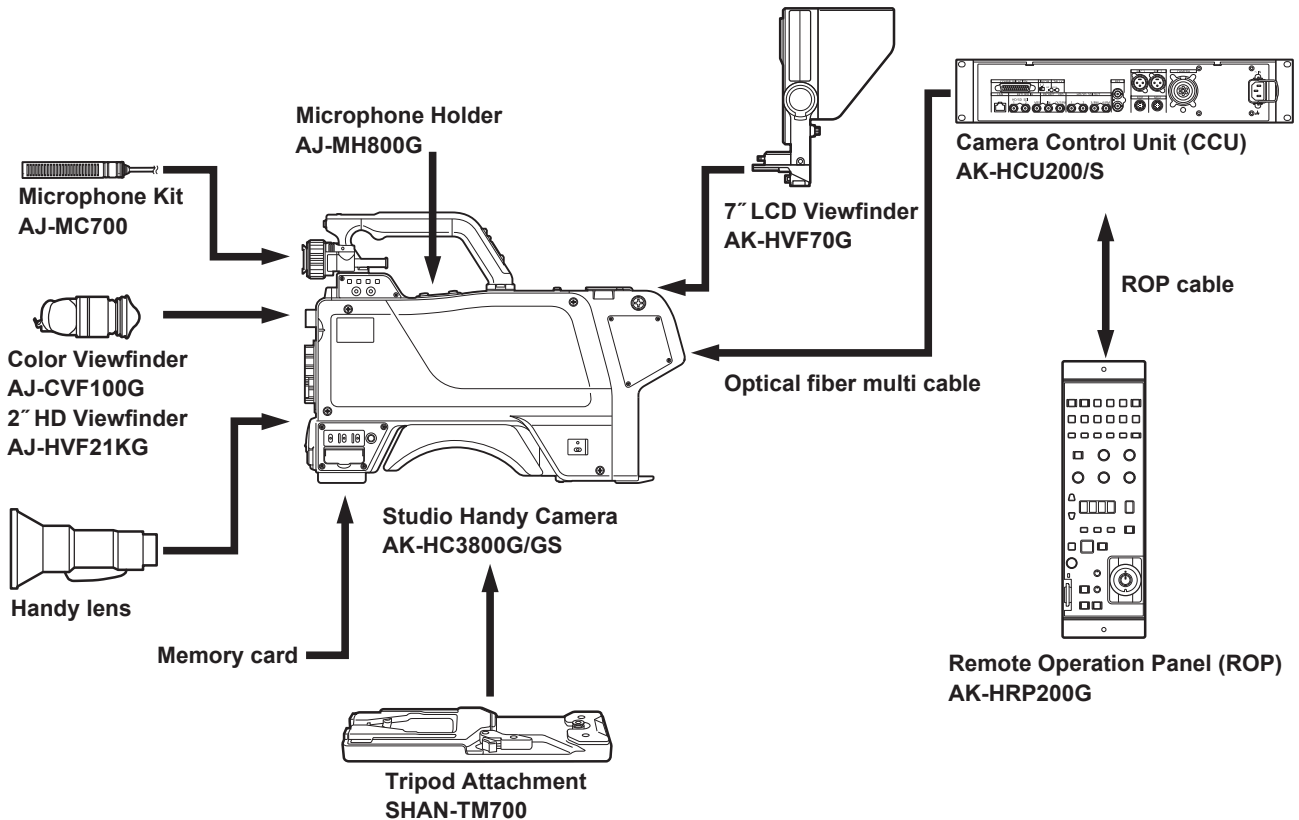

## Outline of peripheral components

### ● Camera Control Unit (CCU: AK-HCU200/S)

This is the camera control unit for the Studio Handy Camera. It is connected to the Studio Handy Camera using an optical fiber multi cable.

#### <Note>

Do not connect a camera control unit other than AK-HCU200/S.

### ● Remote Operation Panel (ROP: AK-HRP200G)

The ROP is connected to the CCU using the ROP cable, and enables the camera, CCU, and lens to be remotely controlled.

### ● Color Viewfinder (1" VF: AJ-CVF100G)

### ● 50.8 mm (2-inch) HD Viewfinder (2" VF: AJ-HVF21KG)

This is the viewfinder for the Studio Handy Camera.

### ● 17.8 cm (7-inch) LCD Viewfinder (7" LCD VF: AK-HVF70G)

This is the LCD viewfinder for the Studio Handy Camera.

## Component connections

Refer to pages 14 to page 15 for the component connections.

After all the components have been connected, set the CCU's main power switch to the ON position.

Then turn on the camera's power switch.



# AK-HC3800G/GS Connector Pins

Numbers in "Parts and their functions"

## 7 OPT FIBER TAJIMI ELECTRONICS

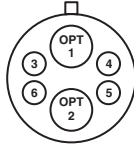

Pin number	Signal
1	OPT-TX (Mark Band = IN)
2	OPT-RX (Mark Band = OUT)
3	DC190V (C)
4	DC190V (H)
5	STBY_SIG
6	STBY_PWP

## LEMO

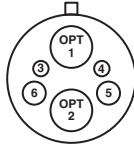

Pin number	Signal
1	OPT-TX (Mark Band = IN)
2	OPT-RX (Mark Band = OUT)
3	STBY_PWP
4	STBY_SIG
5	DC190V (H)
6	DC190V (C)

## 10 INCOM: NC5FBH (NEUTRIK)

Pin number	Signal
1	TALK_GND
2	TALK
3	RECEIVE_GND
4	RECEIVE
5	

## 19 RET CTRL: HR10A-7R-6SC (Hirose Electric)



Pin number	Signal
1	INCOM1_MIC_ON
2	
3	AGND
4	RET_CNT3
5	RET_CNT1
6	RET_CNT2

## 23 DC IN : HA16RA-4P (Hirose Electric)

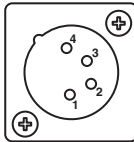

Pin number	Signal
1	GND
2	
3	
4	DC10.8V to 17V
CASE	Frame GND

Numbers in "Parts and their functions"

## 27 MIC1: HA16PRM-3SG(72) (Hirose Electric)



Pin number	Signal
1	MIC1_GND
2	MIC1 (H)
3	MIC1 (C)

## 28 MIC2: HA16PRM-3SG(72) (Hirose Electric)



Pin number	Signal
1	MIC2_GND
2	MIC2 (H)
3	MIC2 (C)

## 29 DC OUT: HR10A-7R-4SC (Hirose Electric)

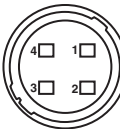

Pin number	Signal
1	UNREG_GND
2	R_TALLY_OUT (contact output)
3	G_TALLY_OUT (contact output)
4	SCRIPT+12V

## 47 LENS: HR10A-10R-12SC (Hirose Electric)

Pin number	Signal
1	LENS_RET SW
2	LENS_VTR SW
3	AGND
4	ENF_SERVO
5	IRIS_CONT
6	LENS+12V
7	IRIS_POSI
8	H_IRIS_A-R
9	EXTENDER
10	ZOOM_POSI
11	FOCUS_POS/L_RXD
12	S_IRIS_A-R/L_TXD

## 48 MIC1(FRONT): HA16PRM-3SG(71) (Hirose Electric)



Pin number	Signal
1	FRONT_MIC_GND
2	FRONT_MIC (H)
3	FRONT_MIC(C)

Numbers in "Parts and their functions"

## 49 VF: HR12-14RF-20SDL (Hirose Electric)

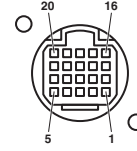

Pin number	Signal
1	VF+12V
2	VF+12V
3	VF+9V (Unused)
4	VF-PBOUT_GND
5	VF-PROUT_GND
6	VF-YOUT
7	VF-YOUT_GND
8	VF_CLK
9	VF_WR
10	VF_DATA
11	GND
12	ZEBRA_SW
13	PEAKING (Unused)
14	TA_BOX_ACT (Unused)
15	VF-PROUT
16	VF-PBOUT
17	VF_SW3 (Unused)
18	FRONT_VR (Unused)
19	TA_TALLY (Unused)
20	F_GND

## 50 REAR VF: D02-29S-N-F0

(Japan Aviation Electronics Industry)

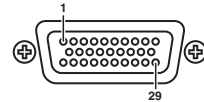

Pin number	Signal
1	Y
2	Pb
3	Pr
4	
5	I2CDATA
6	R_TALLY
7	UP_TALLY
8	
9	VF12V
10	
11	Y-GND
12	Pb-GND
13	Pr-GND
14	A-GND
15	D-GND
16	
17	UNREG-GND
18	
19	F-GND
20	VF P-REQ
21	
22	
23	(P-CONT)
24	I2C-CLK
25	G_TALLY
26	(VF-ACT)
27	
28	
29	

# Status displays on viewfinder screen

Studio Handy Camera settings and messages indicating operating statuses appear on the viewfinder screen. The camera menu [INDICATOR1] and [INDICATOR2] screen and the items which have been set to ON using the switches related to the viewfinder display appear at the top and bottom of the screen. When a setting has been changed or an adjustment made, a message with details of the setting, the status of the adjustment process, or the adjustment result is displayed for about 3 seconds.

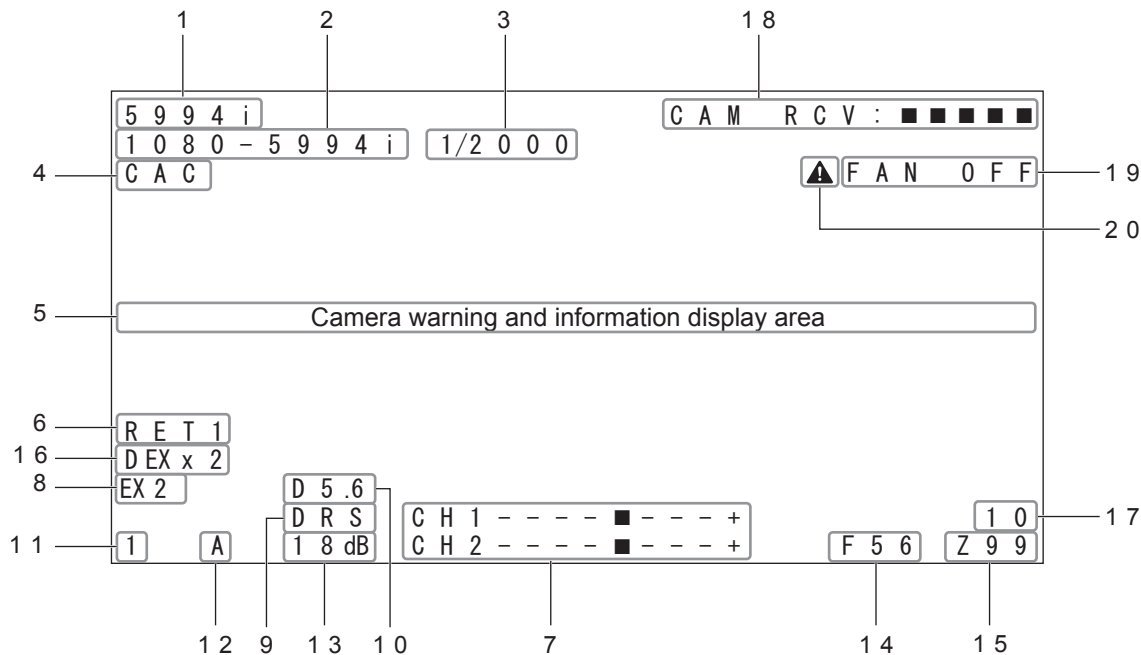

## 1. Camera mode display

59.94i, 50i

## 2. System mode display

1080-59.94i, 1080-50i

## 3. Shutter speed

The shutter value is displayed in accordance with each setting.

● Fixed shutter: “\*/\*\*\*\*”

When [59.94i]:

1/100, 1/120, 1/125, 1/250, 1/500, 1/1000, 1/1500, 1/2000

When [50i]:

1/60, 1/100, 1/125, 1/250, 1/500, 1/1000, 1/1500, 1/2000

● Variable shutter: “\*/\*\*\*\*”

When [59.94i]: 1/60.0 to 1/250

When [50i]: 1/50.0 to 1/250

## 4. Chromatic aberration compensation display

If compensation is selected, [CAC] is displayed.

## 5. Camera warning and information display area

A message indicating the occurrence of an error, the camera settings, the progress made in the adjustments, and the adjustment results appear here for about 3 seconds.

## 6. RETURN ID display

The RETURN ID of the current RETURN output number is displayed.

The corresponding ID (character string) set in [OPERATION] > [RETURN SETTING] > [ID SETTING] > [RETURN1] to [RETURN4] in the camera menu is displayed.

The following RETURN IDs (character strings) are set by factory default.

RET1 (When RETURN1 output)

RET2 (When RETURN2 output)

RET3 (When RETURN3 output)

RET4 (When RETURN4 output)

## 7. AUDIO input channel and level meter

The audio levels for MIC1 (CH1) and MIC2 (CH2) are displayed here.

CH1----■----+

CH2----■----+

## 8. Extender display

[EX2] is displayed when the lens extender is being used.

## 9. DRS display

[DRS] is displayed when the DRS function is ON.

## 10.5600K display

[D5.6] is displayed when the electronic color correction is set to ON.

## 11.Filter position display

The ND filter position is displayed.

1: Clear, 2: 1/4ND, 3: 1/16ND, 4: 1/64ND

## 12.White balance memory display

The automatic adjustment memory selected for the white balance is displayed.

A: The white balance memory selector switch <W.BAL> is set to “A.”

B: The white balance memory selector switch <W.BAL> is set to “B.”

P: The white balance memory selector switch <W.BAL> is set to “PRST.”

## 13.Gain display

The gain setting for the video amplifier selected with the gain selector switch (dB display) is displayed.

12 dB max. setting: -3, 0, 3, 6, 9, 12 dB

36 dB max. setting: -3, 0, 3, 6, 9, 12, 18, 27, 36 dB

## 14.Iris F value display

The approximate value in the iris setting (F value) is displayed.

OPEN, F\*. \* to F\*\*, CLOSE

## 15.Zoom position display

The zoom position is displayed as a numerical value.

Z00 to Z99

<Note>

This display appears only when a lens which has a zoom position output is being used.

## 16.Digital extender display

This is displayed when the digital extender is used.

Double: D EX x 2

## 17.Focus position display

The focus position is displayed as a numerical value.

00 to 99

<Note>

This value is only displayed when a lens that is compatible with CAC is used.

### 18.Optical level display

An optical signal received by the unit is indicated by one of five levels.

CAM RCV: ■

CAM RCV: ■■

CAM RCV: ■■■

CAM RCV: ■■■■

CAM RCV: ■■■■■

### 19.FAN OFF display

This is displayed when FAN POWER is set to OFF.

At this time, if the unit is being used with viewfinders attached to both the front and rear, the power supply of the viewfinder on the front is stopped.

### 20.WARM UP error display

If the temperature is still below the specified temperature approximately 5 seconds after the power is turned on,  is displayed. (→ page 20)

# Checking the operating time

The operating time can be checked in the [HOUR METER] items in the [MAINTENANCE] menu.

HEAD : The operating time of the camera head can be checked.

FAN : The operating time of the fan can be checked.

## Warning displays

### Camera warning displays

Warning displays appear when errors occur in the camera's auto functions.

#### ● When AWB (Automatic White Balance) is executed:

1	AWB LOW LIGHT	Auto white balance cannot be executed because the light quantity is insufficient. Set the light quantity to an appropriate level.
2	AWB HIGH LIGHT	Auto white balance cannot be executed because the light quantity is excessive. Set the light quantity to an appropriate level.
3	AWB R/Bch NG Out Range	The white balance convergence for the red or blue channel cannot be achieved. Shoot a uniformly white object on the screen, and execute AWB.

#### ● When ABB (Automatic Black Balance) is executed:

1	Not Finished	Auto black balance cannot be completed successfully. The lens iris may not be open.
2	R/B Out Range	The black balance convergence for the red or blue channel cannot be achieved. Check whether there are any errors in the image.

#### ● When ASU (Automatic Setup) is executed:

1	LENS CTL NG Out Range	The lens iris cannot be controlled. Review the lens settings.
2	--- R/Bch NG	An error has occurred in the red or blue channel in the process which is being executed. Using a regular chart, check the correct position vis-à-vis the chart and angle of view, check the color temperature setting of the light source, and check whether any other areas are not amenable to control.

### Other warning displays

#### ● FAN STOP

FAN STOP	The fan is stopped because there is a problem. At this time, if the unit is being used with viewfinders attached to both the front and rear, the power supply of the viewfinder on the front is stopped. Stop use immediately, and contact your dealer.
----------	---

#### ● WARM UP

WARM UP	When the power is turned on, preheating is performed because the temperature inside the units has become too low. If the temperature is such that preheating is still required approximately 5 seconds after the power is turned on, this warning disappears and ▲ is displayed. (→ page 18, 19) Check that the WARM UP display or ▲ has disappeared before use.
---------	--

# Menu operations

## Menu display

### 1. Press the menu switch <MENU>

The camera's [USER MENU] screen appears on the viewfinder or monitor.

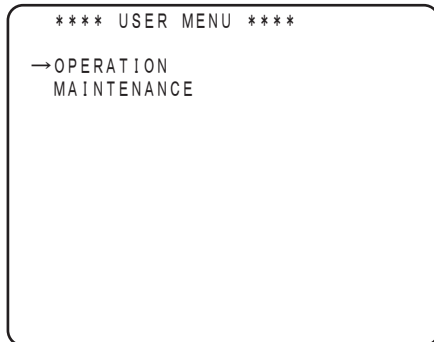

### 2. Turn the <SELECT> JOG dial button, select the menu item, and press the <SELECT> JOG dial button

The menu of the selected item is accessed.

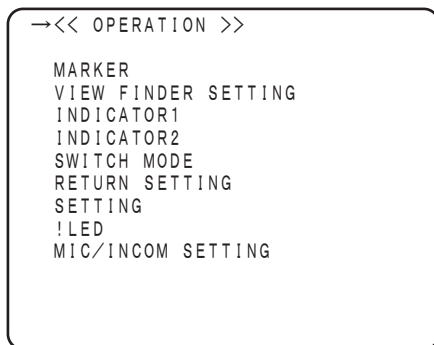

## Entering the menu data

When the item menu is accessed, enter the respective data.

### 1. Turn the <SELECT> JOG dial button, select the menu item to be set, and press the <SELECT> JOG dial button

The setting of the item indicated by the arrow flashes.

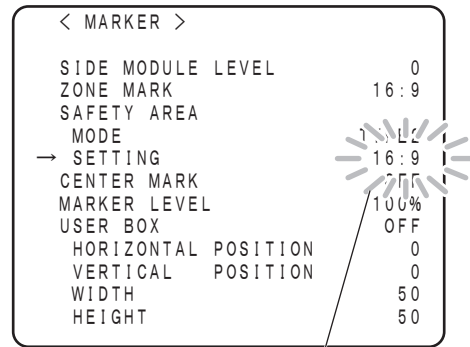

Flashing

### 2. Turn the <SELECT> JOG dial button to change the setting.

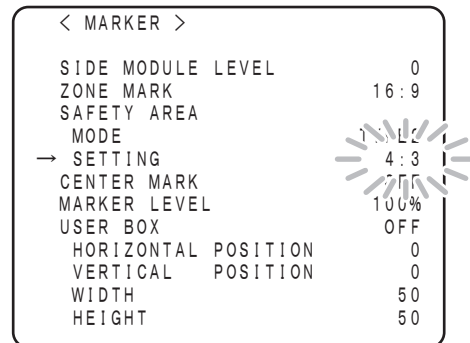

### 3. Press the <SELECT> JOG dial button

The data is confirmed.

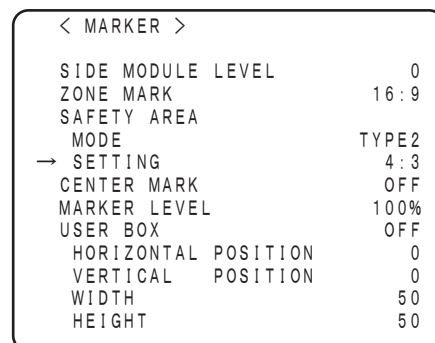

#### <Note>

If the menu screen is turned OFF by pressing the <MENU> switch while the setting is flashing in step 2, the setting is not reflected.

Entering the menu data (entering characters)

1. Press the <SELECT> JOG dial button

The cursor changes to a downward arrow which appears over the first character.

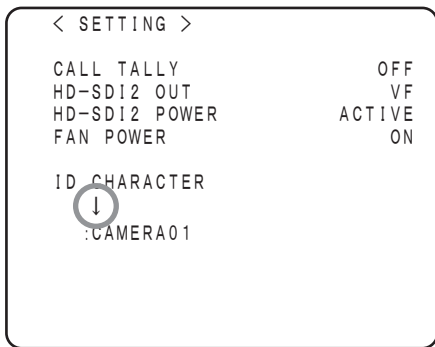
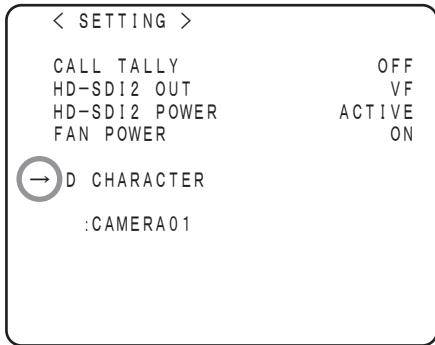

2. Turn the <SELECT> JOG dial button to move the arrow to the character to be changed

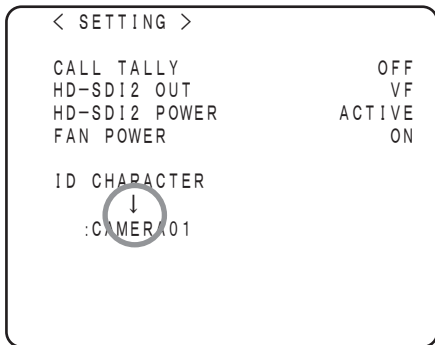

3. Press the <SELECT> JOG dial button

The character to be changed flashes.

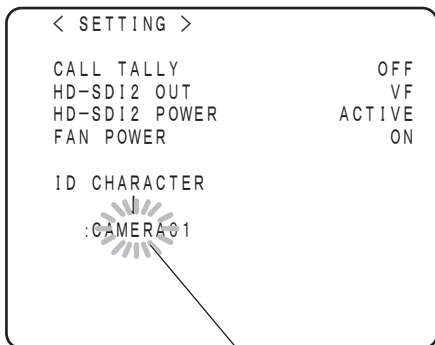

Flashing

4. Turn the <SELECT> JOG dial button to change the character, and press the <SELECT> JOG dial button to confirm the data.

Perform the same operation for all characters to be changed.

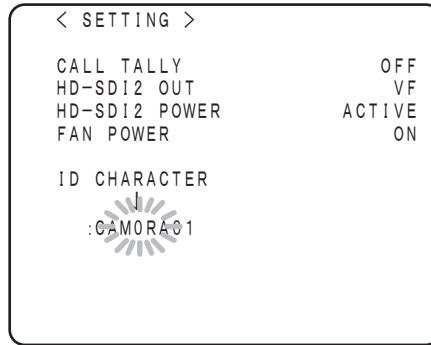

5. Move the downward arrow cursor to the beginning of the menu and press the <SELECT> JOG dial button

The cursor changes to a horizontal arrow and another item can be selected.

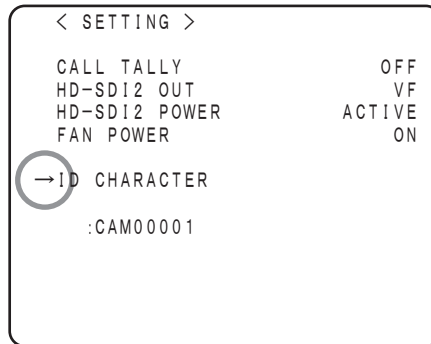
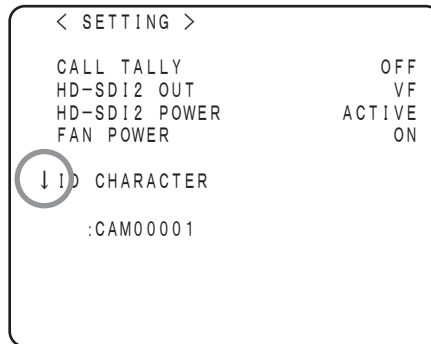

# Menu configuration

## Menu hierarchy

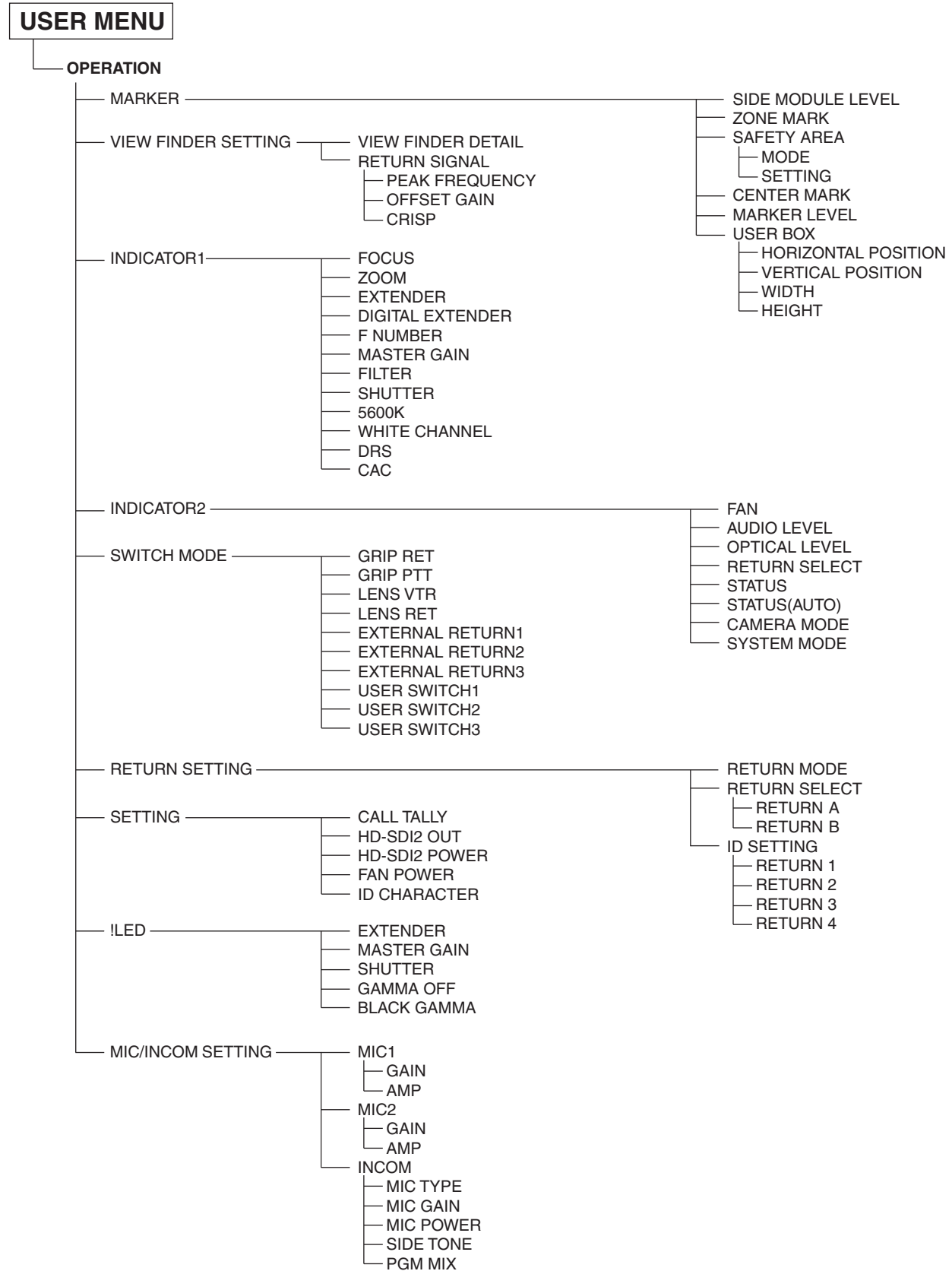

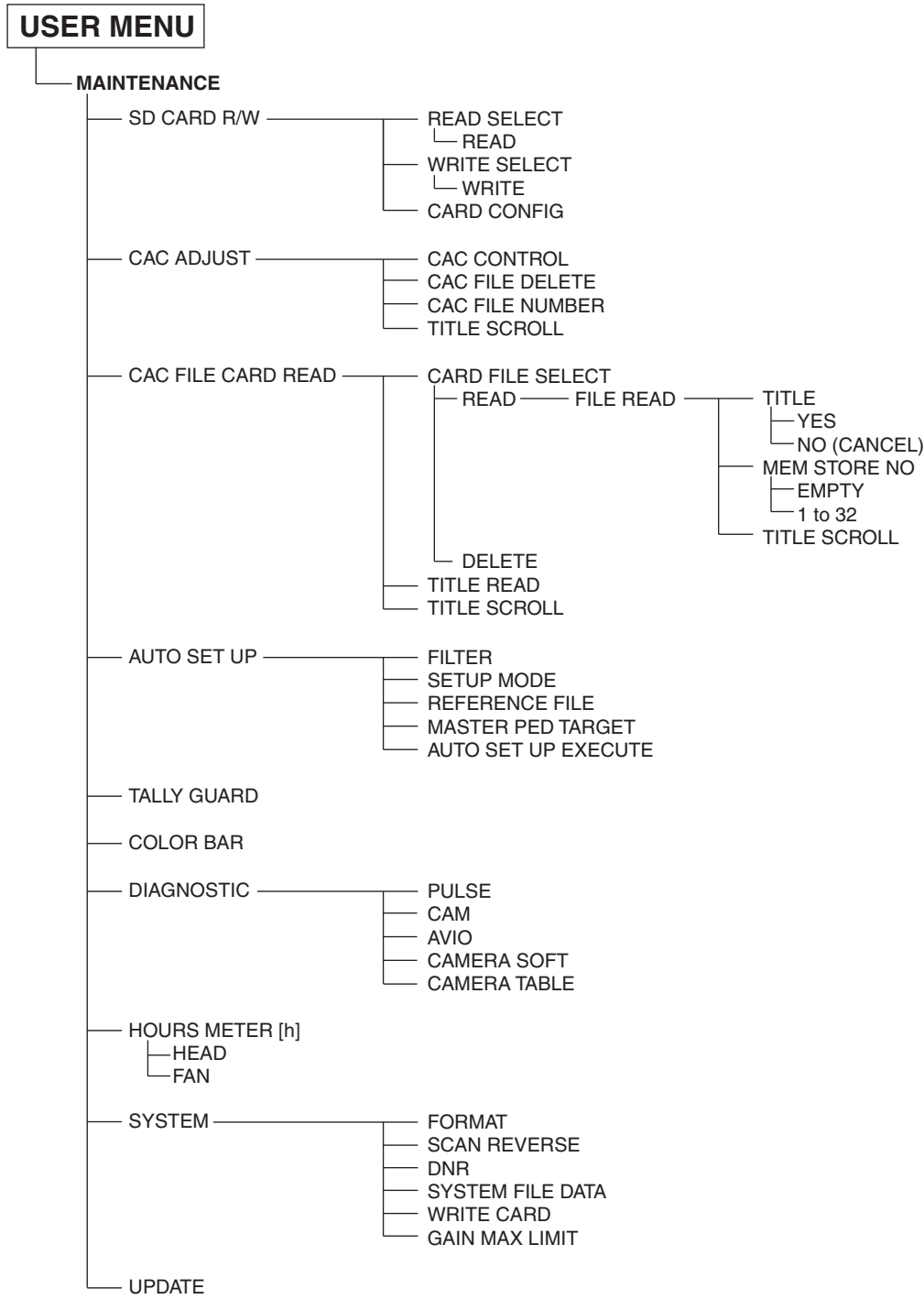



# Table of the adjustment setting ranges

## ■ OPERATION

(The underlined values are factory default settings)

Menu	Item name	Variable step	Variable range	Settings	OPERATION FILE recording item
MARKER	SIDE MODULE LEVEL	1	<u>0</u>   15	When the zone marker is ON, set the brightness modulation level on both sides.	✓
	ZONE MARK	-	<u>OFF</u> 4:3 13:9 14:9 15:9 16:9	Set the zone marker.	✓
	SAFETY AREA	-	-	-	
	MODE	-	<u>TYPE1</u> TYPE2	Set the safety area type.	✓
	SETTING	1% -	<u>80%</u>   100% OFF 4:3 13:9 14:9 15:9 16:9	Set the safety areas for TYPE1 and TYPE2 • When the [MODE] setting is [TYPE1]: 80% to 100% • When the [MODE] setting is [TYPE2]: OFF/4:3/13:9/14:9/15:9/16:9	✓
	CENTER MARK	1	<u>OFF</u> 1   4	Set the shape of the center marker.	✓
	MARKER LEVEL	-	50% 60% 70% 80% 90% 100%	Set the brightness of the markers and OSD.	✓
	USER BOX	-	<u>ON</u> OFF	Set the cursor marker to ON or OFF.	✓
	HORIZONTAL POSITION	1	-50   <u>0</u>   50	Adjust the H position of the cursor.	✓
	VERTICAL POSITION	1	-50   <u>0</u>   50	Adjust the V position of the cursor.	✓
	WIDTH	1	0   <u>50</u>   100	Adjust the width of the cursor.	✓
	HEIGHT	1	0   <u>50</u>   100	Adjust the height of the cursor.	✓
	VIEW FINDER SETTING	VIEW FINDER DETAIL	1	0   <u>6</u>   23	Adjust VF DTL.
RETURN SIGNAL		-	-	-	
PEAK FREQUENCY		-	LOW <u>MID</u> HI	Adjust the peak frequency of the HD RET signal.	✓
OFFSET GAIN		1	<u>0</u>   5	Adjust the DTL offset gain of the HD RET signal.	✓
CRISP		1	0   <u>10</u>   15	Adjust the DTL crisp level of the HD RET signal.	✓

**Table of the adjustment setting ranges (continued)**

(The underlined values are factory default settings)

Menu	Item name	Variable step	Variable range	Settings	OPERATION FILE recording item
INDICATOR1	FOCUS*1	-	ON <u>OFF</u>	Set the focus position display to ON or OFF.	✓
	ZOOM*1	-	ON <u>OFF</u>	Set the zoom position display to ON or OFF.	✓
	EXTENDER	-	ON <u>OFF</u>	Set the extender display to ON or OFF.	✓
	DIGITAL EXTENDER	-	ON <u>OFF</u>	Set the digital extender display to ON or OFF.	✓
	F NUMBER*1	-	ON <u>OFF</u>	Set the iris F value display to ON or OFF.	✓
	MASTER GAIN	-	ON <u>OFF</u>	Set the gain display to ON or OFF.	✓
	FILTER	-	ON <u>OFF</u>	Set the filter position display to ON or OFF.	✓
	SHUTTER	-	ON <u>OFF</u>	Set the electronic shutter display to ON or OFF.	✓
	5600K	-	ON <u>OFF</u>	Set the 5600K display to ON or OFF.	✓
	WHITE CHANNEL	-	ON <u>OFF</u>	Set the white balance memory display to ON or OFF.	✓
	DRS	-	ON <u>OFF</u>	Set the DRS display to ON or OFF.	✓
	CAC	-	ON <u>OFF</u>	Set the chromatic aberration compensation (CAC) display to ON or OFF.	✓
INDICATOR2	FAN	-	ON <u>OFF</u>	Set the FAN OFF display to ON or OFF.	✓
	AUDIO LEVEL	-	ON <u>OFF</u>	Set the audio level (level meter) display to ON or OFF.	✓
	OPTICAL LEVEL	-	ON <u>OFF</u>	Set the level of the optical signal to be received by this unit to ON/OFF.	✓
	RETURN SELECT	-	ON <u>OFF</u>	Set the RETURN ID display to ON or OFF.	✓
	STATUS	-	ON <u>OFF</u>	Set the display appearing when functions are selected to ON or OFF.	✓
	STATUS(AUTO)	-	ON <u>OFF</u>	Set the display appearing when AWB/ABB/ASU are started or finished to ON or OFF.	✓
	CAMERA MODE	-	ON <u>OFF</u>	Set the camera mode display to ON or OFF.	✓
	SYSTEM MODE	-	ON <u>OFF</u>	Set the system mode display to ON or OFF.	✓

\*1 This is displayed when you use a lens that outputs position information.

**Table of the adjustment setting ranges (continued)**

(The underlined values are factory default settings)

Menu	Item name	Variable step	Variable range	Settings	OPERATION FILE recording item
SWITCH MODE	GRIP RET	-	RET <u>A</u> RET B PTT	Select the grip RET SW <RET> function.	✓
	GRIP PTT	-	RET A RET B <u>PTT</u>	Select the grip PTT SW <PTT> function.	✓
	LENS VTR	-	RET A <u>RET B</u> PTT INH	Select the handy lens RET SW function.	✓
	LENS RET	-	<u>RET A</u> RET B	Select the handy lens RET SW function.	✓
	EXTERNAL RETURN1	-	<u>RET A</u> RET B D.EXT	Select the external return control SW1 function.	✓
	EXTERNAL RETURN2	-	RET A <u>RET B</u> D.EXT	Select the external return control SW2 function.	✓
	EXTERNAL RETURN3	-	RET A <u>RET B</u> D.EXT	Select the external return control SW3 function.	✓
	USER SWITCH1	-	<u>RET A</u> RET B PTT DISP MARK D.EXT	Select the assignable SW1 <USER1> function.	✓
	USER SWITCH2	-	RET A RET B <u>PTT</u> DISP MARK D.EXT	Select the assignable SW2 <USER2> function.	✓
	USER SWITCH3	-	RET A RET B <u>PTT</u> DISP MARK D.EXT	Select the assignable SW3 <USER3> function.	✓
RETURN SETTING	RETURN MODE	-	<u>NORM</u> TOGGLE SEQ.	Set the RET SW operation mode.	✓
	RETURN SELECT	-	-	-	
	RETURN A	-	<u>1</u> 2 3 4	Assign the return signal to Return A.	✓
	RETURN B	-	1 <u>2</u> 3 4	Assign the return signal to Return B.	✓
	ID SETTING	-	-	-	
	RETURN 1	-	RET1	Set the name of return video 1. • Up to 5 characters can be entered.	✓
	RETURN 2	-	RET2	Set the name of return video 2. • Up to 5 characters can be entered.	✓
	RETURN 3	-	RET3	Set the name of return video 3. • Up to 5 characters can be entered.	✓
	RETURN 4	-	RET4	Set the name of return video 4. • Up to 5 characters can be entered.	✓

**Table of the adjustment setting ranges (continued)**

(The underlined values are factory default settings)

Menu	Item name	Variable step	Variable range	Settings	OPERATION FILE recording item
SETTING	CALL TALLY	-	<u>OFF</u> R T R&T	Set the tally light ON when calling. R: The RED tally lights T: The UP tally lights R&T: Both the RED tally and UP tally light	✓
	HD-SDI2 OUT	-	MAIN <u>VF</u> RET	Select the camera HD-SDI output 2 connector <HD-SDI2> mode.	✓
	HD-SDI2 POWER	-	<u>ACTIVE</u> SAVE	Set the HD-SDI2 power to ON or OFF.	✓
	FAN POWER	-	ON OFF	Set the camera FAN power to ON or OFF. • The setting is reset to [ON] when the power is turned on.	
	ID CHARACTER	-	*****	Set the camera name. • Up to 10 characters can be entered.	✓
ILED*2	EXTENDER	-	ON <u>OFF</u>	Set the status display to ON or OFF when the lens extender is ON.	✓
	MASTER GAIN	-	ON <u>OFF</u>	Set the status display to ON or OFF when the gain is other than 0 dB.	✓
	SHUTTER	-	ON <u>OFF</u>	Set the status display to ON or OFF when the electronic shutter is ON.	✓
	GAMMA OFF	-	ON <u>OFF</u>	Set the status display to ON or OFF when the gamma is OFF.	✓
	BLACK GAMMA	-	ON <u>OFF</u>	Set the status display to ON or OFF when the black gamma is ON.	✓
MIC/INCOM SETTING	MIC1	-	-	-	
	GAIN	-	20dB 40dB <u>60dB</u>	Set the gain of MIC1.	✓
	AMP	1dB	-20dB   <u>0dB</u>   20dB	Set the amplitude of MIC1.	✓
	MIC2	-	-	-	
	GAIN	-	20dB 40dB <u>60dB</u>	Select the input level of the rear microphone, and set the gain of MIC2.	✓
	AMP	1dB	-20dB   <u>0dB</u>   20dB	Set the amplitude of MIC2.	✓
	INCOM	-	-	-	
	MIC TYPE	-	DYN ECM CBN	Select the type of the intercom microphone. DYN: Dynamic type ECM: Condenser type CBN: Carbon type	✓
	MIC GAIN	1dB	-12dB   <u>0dB</u>   12dB	Select the gain of the intercom microphone.	✓
	MIC POWER	-	ON <u>OFF</u>	Set the power supply of the intercom microphone to ON or OFF.	✓
	SIDE TONE	3dB	OFF -36dB   <u>-6dB</u>   0dB	Set the side tone of the intercom to ON or OFF.	✓
	PGM MIX	-	ON <u>OFF</u>	Set the PGM mixing of the intercom to ON or OFF.	✓

\*2 If an item set to [ON] in the [ILED] menu becomes in an irregular operating state on this unit, the [!] LED in the viewfinder lights.

**Table of the adjustment setting ranges (continued)**

■ MAINTENANCE

(The underlined values are factory default settings)

Menu	Item name	Variable step	Variable range	Settings	OPERATION FILE recording item
SD CARD R/W	READ SELECT	1	<u>1</u>   8	Select the camera operation file for READ.	
	READ	-	YES <u>NO</u>	Execute reading of the camera operation file.	
	WRITE SELECT	1	<u>1</u>   8	Select the camera operation file for WRITE.	
	WRITE	-	YES <u>NO</u>	Execute writing of the camera operation file.	
	CARD FORMAT	-	YES <u>NO</u>	Execute FORMAT of the memory card.	
CAC ADJUST	CAC CONTROL	-	<u>ON</u> OFF	Enable or disable chromatic aberration compensation.	
	CAC FILE DELETE* <sup>1</sup>	-	YES <u>NO</u>	Execute deletion of the CAC file selected in the [CAC FILE NUMBER] item.	
	CAC FILE NUMBER	1	<u>1</u>   32	Select the CAC file for the CAC MANUAL compensation, and select the CAC file to be deleted in [CAC FILE DELETE].	
	TITLE SCROLL * <sup>2</sup>	1	<u>1</u>   25	Scroll through the CAC file titles.	
CAC FILE CARD READ	CARD FILE SELECT	1	<u>1</u>   32	Select the number for the operation (READ/DELETE).	
	READ * <sup>3</sup>	-	YES <u>NO</u>	Execute reading from the memory card.	
	DELETE * <sup>5</sup>	-	YES <u>NO</u>	Execute deletion of the CAC file in the memory card.	
	TITLE READ	-	YES <u>NO</u>	Read the CAC file titles in the memory card and display them.	
	TITLE SCROLL	1	<u>1</u>   25	Scroll through the CAC file titles in the memory card.	
FILE READ * <sup>4</sup>	TITLE	-	-	Display the CAC file title selected in the [READ] item of [CAC FILE CARD READ].	
	YES	-	-	Store the CAC file read from the memory card to internal memory.	
	NO	-	-	Do not store the CAC file read from the memory card to internal memory. (CANCEL)	
	MEM STORE NO * <sup>6</sup>	1	<u>EMPTY</u> 1   32	Select the number for storing the CAC file to internal memory. EMPTY: Searches in numerical order and stores the data to an empty location. 1 to 32: Stores the data to the selected number.	
	TITLE SCROLL * <sup>2</sup>	1	<u>1</u>   25	Scroll through the CAC file titles in internal memory.	

\*<sup>1</sup> Delete the CAC file that is stored in the internal memory of the camera and selected in the [CAC FILE NUMBER] item.

Press the <SELECT> JOG dial button to move the cursor to the YES/NO selection screen.

\*<sup>2</sup> When the CAC file is selected with the cursor and the <SELECT> JOG dial button is pressed, the titles can be scrolled by turning the <SELECT> JOG dial button.

\*<sup>3</sup> Press the <SELECT> JOG dial button to move the cursor to the [FILE READ] screen.

\*<sup>4</sup> Can be accessed from [CAC FILE CARD READ]>[CARD FILE SELECT]>[READ].

\*<sup>5</sup> Press the <SELECT> JOG dial button to move the cursor to the YES/NO selection screen.

\*<sup>6</sup> If a CAC file is already stored for the selected number, it will be overwritten.

**Table of the adjustment setting ranges (continued)**

(The underlined values are factory default settings)

Menu	Item name	Variable step	Variable range	Settings	OPERATION FILE recording item
AUTO SET UP	FILTER	-	REF CURRENT	Set the ND/CC filter mode when auto setup.	
	SETUP MODE	-	FULL EASY	Set the auto setup mode.	
	REFERENCE FILE	-	FACTORY USER1 USER2 USER3	Set the reference file for auto setup.	
	MASTER PED TARGET	0.5 %	0.0%   <u>2.0%</u>   7.5%	Set the master pedestal for auto setup.	
	AUTO SET UP EXECUTE	-	YES NO	Execute the auto setup.	
TALLY GUARD		-	ON <u>OFF</u>	Prohibit the execution of AWB, ABB, and ASU when the tally is ON.	
COLOR BAR		-	SMPTE FULL BAR ARIB	Select the type of the color bar.	
DIAGNOSTIC	PULSE	-	(Version display)	Display the PULSE FPGA version.	
	CAM	-	(Version display)	Display the CAM FPGA version.	
	AVIO	-	(Version display)	Display the AVIO FPGA version.	
	CAMERA SOFT	-	(Version display)	Display the CAMERA SOFT version.	
	CAMERA TABLE	-	(Version display)	Display the CAMERA TABLE version.	
HOURS METER [h]		-	-	-	
HEAD		1	0   65000	Display the operating time of the camera head.	
FAN		1	0   65000	Display the operating time of the fan.	
SYSTEM	FORMAT	-	<u>59.94i</u> 50i	Set the system format.	
	SCAN REVERSE	-	ON <u>OFF</u>	Set SCAN REVERSE to ON or OFF.	
	DNR	-	ON OFF	Set DNR to ON or OFF.	
	SYSTEM FILE DATA	-	-	-	
	WRITE CARD	-	YES <u>NO</u>	Save the hour, version, and serial number to the memory card.	
	GAIN MAX LIMIT	-	12dB <u>36dB</u>	Set the GAIN MAX LIMIT value (12dB or 36dB).	
UPDATE		-	YES <u>NO</u>	Update the software.	

## Data handled in the camera

The following shows the data handled in the camera.

Managed system component	Name	Quantity	Description
Camera	Operation data (for camera)	1 to 8	Equipment configuration data held by the camera, such as marker and button settings set in [OPERATION] in the camera menu. It is managed by the camera. It can be saved and read by camera menu operation. It can also be saved and read to/from the memory card by camera menu operation.
	Lens file	1 to 32	This data is used by video engineers (VE) to correct the characteristics specific to the lenses and is managed by the camera. It can be saved and read by operation on the ROP. It can also be saved and read to/from the memory card on the ROP. For a list of data, refer to the Operating Instructions for AK-HRP200G.
	CAC file	1 to 32	This data is used to correct the chromatic aberrations specific to the lenses and is managed by the camera. It can only be read from the memory card by camera menu operation.
	Scene file	1 to 4	This data for creating pictures is handled mainly by video engineers (VE) and is managed by the camera. It can be saved and read by operation on the ROP. It can also be saved and read to/from the memory card on the ROP. For a list of data, refer to the Operating Instructions for AK-HRP200G.

### CAC file

#### AK-HC3800G/GS (Camera)

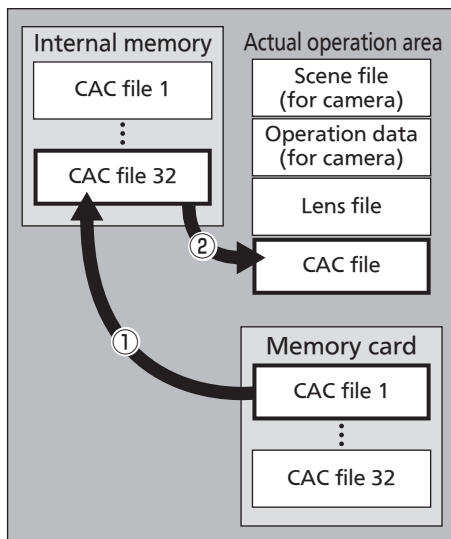

#### ① Reading the CAC file

The CAC file can be transferred from the memory card inserted into the memory card slot on the camera to the internal memory with [MAINTENANCE]>[CAC FILE CARD READ] in the camera menu. The CAC file name specific to each lens can be downloaded from the website\*1.

If 32 or more CAC files are in the memory card, 32 files are read in order from the newest.

\*1 You can check the CAC compatible lenses guaranteed for use in this unit on Panasonic's website. You can also obtain a CAC file from the support desk on Panasonic's website.  
<http://pro-av.panasonic.net/>

#### ② Accessing the CAC file

The CAC file is selected automatically according to the lens and accessed in the actual operation area.

### Operation data (for camera)

#### AK-HC3800G/GS (Camera)

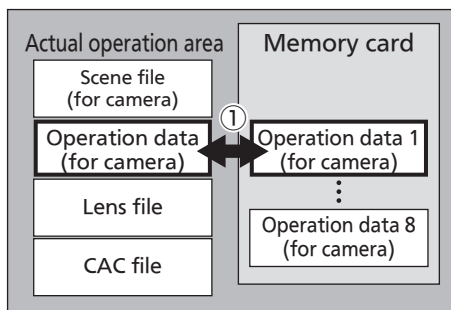

#### ① Saving and reading the operation data

Operation data can be transferred from the memory card inserted into the memory card slot on the camera to the actual operation area with [MAINTENANCE]>[SD CARD R/W] in the camera menu. Furthermore, operation data in the actual operation area can be saved to the memory card.

The save date and time are fixed to "0:00, January 1, 2099."

# Updating the firmware in this unit

Refer to the following website for whether or not there are new updates for the firmware and for operation instructions.  
<http://pro-av.panasonic.net/>

## Dimensional outline drawing

Unit: mm (inch)

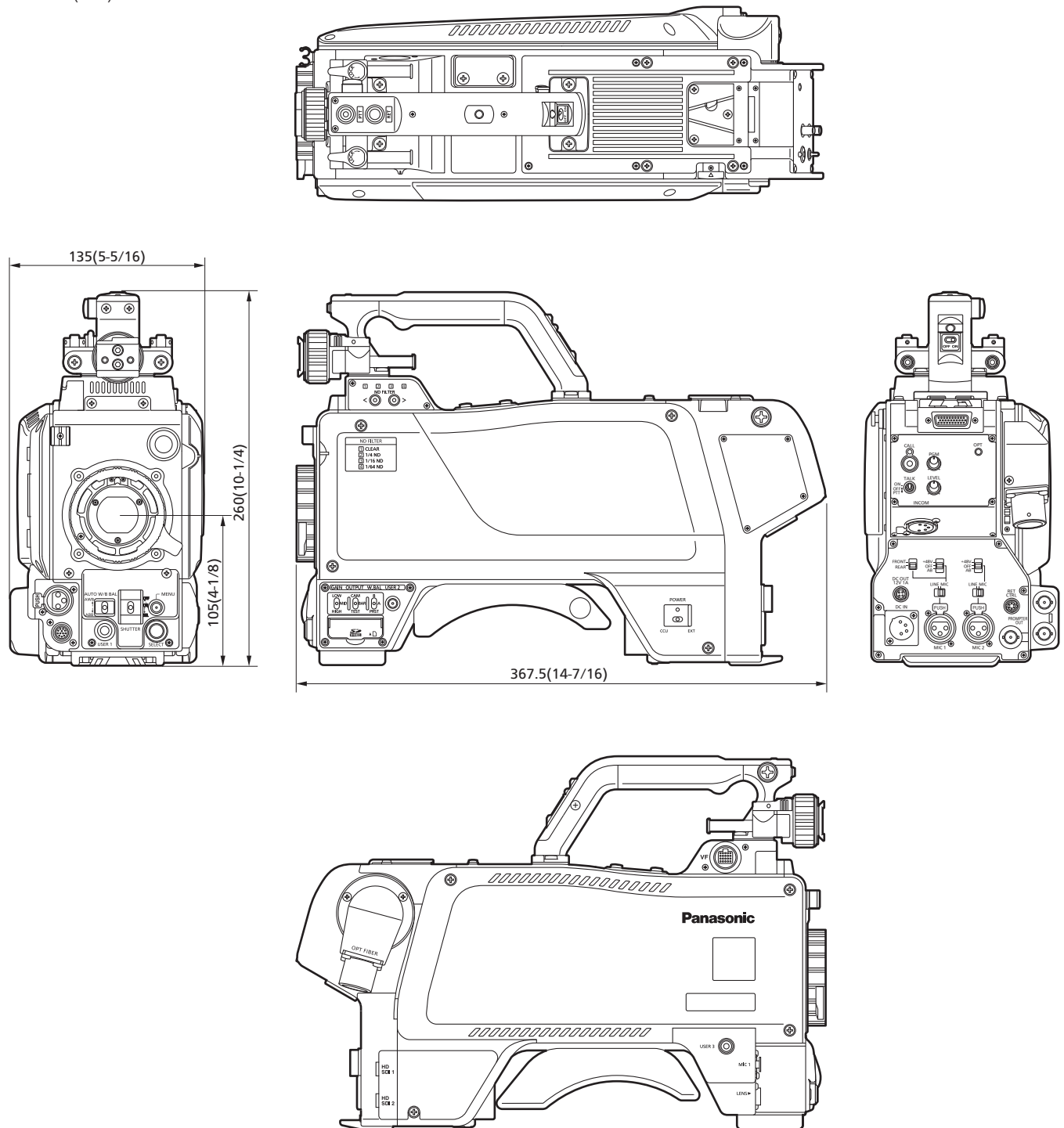



# Specifications

## ■ General

### Power supply input

Power supply	: 12 V DC (during external power supply operation) 190 V DC (when CCU is connected)
Power consumption	: 25 W (during external power supply operation, camera only) 53 W (maximum power during external power supply operation when maximum power supplied for each output connector while all accessories are connected) 60 W (maximum power when CCU is connected and maximum power supplied for each output connector while all accessories are connected)

 indicates safety information.

Operating temperature	: -10 °C to 45 °C (14 °F to 113 °F) [Preheating required at temperatures below 0 °C (32 °F)]
Storage temperature	: -20 °C to 60 °C (-4 °F to 140 °F)
Operating humidity	: 85 % or less
Weight	: Approx. 3.7 kg (8.16 lb)
Dimensions	: 135 mm x 260 mm x 367.5 mm (W x H x D) (5-5/16 inches x 10-1/4 inches x 14-7/16 inches) [excluding protrusions]

## Basic items

1) Pickup device	: 2/3" 2.2 million pixel IT, CCD x 3
2) System	: GBR pickup system
3) Color separation optical system	: f/1.4 prism
4) Optical filter	: ND: Clear, 1/4, 1/16, 1/64
5) Lens mount	: Bayonet type
6) Output standard	: SMPTE 292M
7) Sensitivity	: F11 (When vertical frequency is 59.94 Hz) F12 (When vertical frequency is 50 Hz)
8) Horizontal resolution	: 1100 TV lines
9) S/N	: 60 dB or higher
10) Horizontal frequency	: 33.716 kHz, 1125-line frame (Vertical frequency: 59.94 Hz) 28.125 kHz, 1125-line frame (Vertical frequency: 50 Hz)
11) Vertical frequency	: 59.94 Hz or 50 Hz, interlace

## Input/output signals

1) MIC input	: -60 dBu to 4 dBu (XLR 3-pin female x 2) Gain selected by camera menu
2) Intercom	: Input: -60 dBu to -20 dBu Output: 100 mW max. (XLR 5-pin female x 1)
3) HD-SDI1/HD-SDI2 output	: HD signal = 0.8 V [p-p], 75 ohms (BNC) The HD-SDI2 signal output can be added to the regular images using the camera menu item setting and switched to the VF or RET image output.
4) Prompt output	: VBS signal = 1 V [p-p], 75 ohms (BNC)
5) DC OUT	: 12 V, MAX. 1A

## Control

1) Power switching	: CCU, OFF, EXT
2) USER 1, 2, 3	: Functions specified by menu items can be assigned to the switch.
3) RET A/B selection	: For selecting the return signal
4) RET/PTT switching	: RET, PPT
5) Gain selection*1	: LOW, MID, HIGH
6) Output selection*1	: CAM, BAR, TEST
7) White balance mode*1	: A, B, preset
8) Shutter speed selection*1	: 1/100, 1/120, 1/125, 1/250, 1/500, 1/1000, 1/1500, 1/2000
9) AWB, ABB SW*1	
10) Menu selection	
11) CALL SW	
12) Intercom	: MIC ON/OFF, receiving level, or PGM level

13) MIC setting : MIC power, MIC gain, MIC1 selection

\*1 When the CCU is connected, the selection functions cannot be used. Control is performed from the ROP.

# Index

---

<b>A</b>		
Accessories .....	6	
Assignable switches .....	12	
AWB/ABB start switch .....	13	
<b>B</b>		
Back tally LED selector switch .....	10	
<b>C</b>		
CAC file .....	31	
CALL LED .....	10	
CALL switch .....	10	
Camera HD-SDI output1 connector .....	11	
Camera HD-SDI output2 connector .....	11	
Camera number sheet .....	9	
Camera output selector switch .....	12	
Component system configuration .....	16	
Connector Pins .....	17	
<b>D</b>		
DC output connector .....	11	
Dimensional outline drawing .....	32	
<b>E</b>		
Electronic shutter selector switch .....	13	
External power supply input connector .....	11	
<b>F</b>		
Frame frequency .....	7	
Front MIC1 connector .....	13	
<b>G</b>		
Gain selector switch .....	12	
Grip PTT switch .....	12	
Grip RET switch .....	12	
<b>I</b>		
INCOM connector .....	10	
INCOM level control .....	10	
INCOM MIC ON/OFF switch .....	10	
INCOM/PGM level control .....	10	
<b>J</b>		
JOG dial button .....	13	
<b>L</b>		
Lens cable clamps .....	9	
Lens clamp lever .....	9	
Lens connector .....	13	
Lens mount .....	9	
<b>M</b>		
MAINTENANCE .....	29	
Memory card slot .....	12	
Menu		
configuration .....	23	
operation .....	21	
Menu switch .....	13	
MIC1 power selector switch .....	11	
MIC1 selector switch1 .....	11	
MIC1 selector switch2 .....	11	
MIC2 power selector switch .....	11	
MIC2 selector switch .....	11	
Microphone		
connecting .....	15	
microphone cable clamps .....	9	
<b>N</b>		
ND filter selector LED .....	12	
ND filter selector switch .....	12	
<b>O</b>		
OPERATION .....	25	
Optical fiber connector .....	9	
OPT LED .....	10	
<b>P</b>		
Peripheral components .....	16	
Power LED .....	10	
Power switch .....	10	
PROMPT output connector .....	11	
<b>R</b>		
Rear MIC1 connector .....	11	
Rear MIC2 connector .....	11	
Rear viewfinder connector .....	13	
RET switching control connector .....	11	
<b>S</b>		
Shoulder pad .....	9	
Specifications .....	33	
<b>T</b>		
Tripod .....	9	
<b>V</b>		
Viewfinder		
attaching/detaching .....	14	
on screen display .....	18	
Viewfinder connector .....	13	
<b>W</b>		
Warning .....	20	
White balance memory selector switch .....	12	

A series of horizontal dashed lines for writing.

## Information for Users on Collection and Disposal of Old Equipment and used Batteries



These symbols on the products, packaging, and/or accompanying documents mean that used electrical and electronic products and batteries should not be mixed with general household waste. For proper treatment, recovery and recycling of old products and used batteries, please take them to applicable collection points, in accordance with your national legislation and the Directives 2002/96/EC and 2006/66/EC.



EU

By disposing of these products and batteries correctly, you will help to save valuable resources and prevent any potential negative effects on human health and the environment which could otherwise arise from inappropriate waste handling.



For more information about collection and recycling of old products and batteries, please contact your local municipality, your waste disposal service or the point of sale where you purchased the items.

Penalties may be applicable for incorrect disposal of this waste, in accordance with national legislation.

EU

### For business users in the European Union

If you wish to discard electrical and electronic equipment, please contact your dealer or supplier for further information.



Cd

### Information on Disposal in other Countries outside the European Union

These symbols are only valid in the European Union. If you wish to discard these items, please contact your local authorities or dealer and ask for the correct method of disposal.

### Note for the battery symbol (bottom two symbol examples):

This symbol might be used in combination with a chemical symbol. In this case it complies with the requirement set by the Directive for the chemical involved.

**Panasonic Corporation**

Web Site: <http://panasonic.net>

**パナソニック株式会社 プロフェッショナルAVビジネスユニット**

〒571-8503 大阪府門真市松葉町2番15号 ☎ (06) 6901-1161

© Panasonic Corporation 2012