

HP ProLiant DL360 G7 Server User Guide



Part Number 608341-004
October 2010 (Fourth Edition)

© Copyright 2010 Hewlett-Packard Development Company, L.P.

The information contained herein is subject to change without notice. The only warranties for HP products and services are set forth in the express warranty statements accompanying such products and services. Nothing herein should be construed as constituting an additional warranty. HP shall not be liable for technical or editorial errors or omissions contained herein.

Microsoft and Windows are U.S. registered trademarks of Microsoft Corporation.

Intended audience

This document is for the person who installs, administers, and troubleshoots servers and storage systems. HP assumes you are qualified in the servicing of computer equipment and trained in recognizing hazards in products with hazardous energy levels.

Contents

Component identification	7
Front panel components	7
Front panel LEDs and buttons	8
Rear panel components	9
Rear panel LEDs and buttons	10
System board components	11
DIMM slots	12
System maintenance switch	12
NMI jumper	13
Systems Insight Display LEDs	13
Systems Insight Display LED combinations	14
SAS and SATA device numbers	15
SAS and SATA hard drive LEDs	16
Fan modules	16
T-10/T-15 Torx screwdriver	18
Operations	19
Power up the server	19
Power down the server	19
Extend the server from the rack	19
Access the HP Systems Insight Display	20
Remove the access panel	21
Install the access panel	21
Remove the BBWC battery pack or the FBWC capacitor pack	21
Remove the air baffle	22
Install the air baffle	22
Remove the PCI riser board assembly	23
Install the PCI riser board assembly	24
Setup	26
Optional installation services	26
Rack planning resources	26
Optimum environment	27
Space and airflow requirements	27
Temperature requirements	27
Power requirements	28
Electrical grounding requirements	28
Rack warnings	29
Contents of the server shipping carton	29
Installing hardware options	29
Installing the server into the rack	30
Powering up and configuring the server	31
Installing the operating system	32
Registering the server	32
Hardware options installation	33
Introduction	33

Processor and fan module option	33
Memory options	38
Memory subsystem architecture	38
Single, dual-, and quad-rank DIMMs	39
DIMM identification	39
Memory configurations.....	40
General DIMM slot population guidelines	42
Installing a DIMM	46
Hot-plug SAS and SATA hard drive options	47
Removing hard drive blanks.....	47
Removing hard drive bezel blanks	47
Removing the dual hard drive bezel blank	48
Removing a hot-plug SAS hard drive	48
Installing a SAS hard drive	49
DVD-ROM and DVD-RW drive option.....	49
Hard drive blackplane option	52
Controller options.....	56
Installing the cache module.....	57
Installing the BBWC battery pack or the FBWC capacitor pack	58
Expansion board options.....	59
Installing an expansion board	59
Installing a PCI-X riser board	60
PCI thermal - power option	61
Redundant hot-plug power supply option	63
HP Trusted Platform Module option	66
Installing the Trusted Platform Module board	67
Retaining the recovery key/password	68
Enabling the Trusted Platform Module.....	68

Cabling 70

Cabling overview	70
Hard drive backplane cabling	70
BBWC battery pack or FBWC capacitor pack cabling	71
DVD-ROM and DVD-RW drive cabling	72
Power button and Systems Insight Display cabling	72
PCI power cabling.....	73

Software and configuration utilities 74

Configuration tools	74
SmartStart software.....	74
HP ROM-Based Setup Utility.....	74
Array Configuration Utility	78
Option ROM Configuration for Arrays	78
Re-entering the server serial number and product ID	79
Management tools.....	79
Automatic Server Recovery	79
ROMPaq utility	80
Integrated Lights-Out 3 technology	80
Erase Utility	80
Redundant ROM support	81
USB support.....	81
Diagnostic tools	81
HP Insight Diagnostics	81
HP Insight Diagnostics survey functionality	82

Integrated Management Log	82
Remote support and analysis tools	83
HP Insight Remote Support software	83
Keeping the system current	83
Drivers	83
Version control	84
ProLiant Support Packs	84
Operating System Version Support	84
Firmware	84
HP Smart Update Manager	84
Change control and proactive notification	85
Care Pack	85
Troubleshooting	86
Troubleshooting resources	86
Pre-diagnostic steps	86
Important safety information	86
Symptom information	88
Prepare the server for diagnosis	89
Loose connections	89
Service notifications	90
Troubleshooting flowcharts	90
Start diagnosis flowchart	90
General diagnosis flowchart	91
Server power-on problems flowchart	93
POST problems flowchart	96
OS boot problems flowchart	97
Server fault indications flowchart	99
POST error messages and beep codes	101
System battery	102
Regulatory compliance notices	103
Regulatory compliance identification numbers	103
Federal Communications Commission notice	103
FCC rating label	103
Class A equipment	103
Class B equipment	103
Declaration of conformity for products marked with the FCC logo, United States only	104
Modifications	104
Cables	104
Canadian notice (Avis Canadien)	105
European Union regulatory notice	105
Disposal of waste equipment by users in private households in the European Union	106
Japanese notice	106
BSMI notice	106
Korean notice	107
Chinese notice	107
Laser compliance	107
Battery replacement notice	107
Taiwan battery recycling notice	108
Power cord statement for Japan	108
Acoustics statement for Germany (Geräuschemission)	108
Electrostatic discharge	109

Preventing electrostatic discharge	109
Grounding methods to prevent electrostatic discharge	109
Specifications	110
Environmental specifications	110
Server specifications	110
Power supply specifications	110
HP 460 W CS HE Power Supply (92%) specifications	111
HP 460 W CS Platinum Power Supply (94%) specifications	111
HP 750 W CS HE Power Supply (92%) specifications	112
HP 750 W CS Platinum Power Supply (94%) specifications	112
HP 1200 W CS HE Power Supply (90%) specifications	113
HP 1200 W CS -48Vdc Power Supply specifications	113
Hot-plug power supply calculations.....	114
Technical support.....	115
Before you contact HP.....	115
HP contact information	115
Customer Self Repair	115
Acronyms and abbreviations.....	123
Index.....	126

Component identification

Front panel components

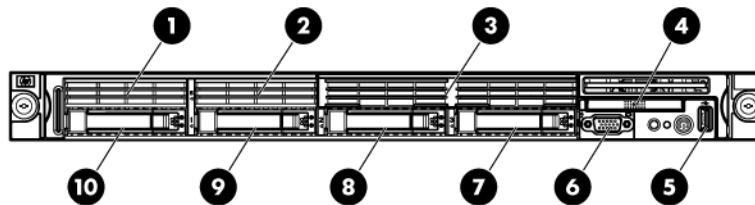

Item	Description
1	Hard drive bay 5 (optional)*
2	Hard drive bay 6 (optional)*
3	DVD tray/hard drive bays 7 and 8 (optional)*
4	HP Systems Insight Display
5	Front USB connector
6	Video connector
7	Hard drive bay 4
8	Hard drive bay 3
9	Hard drive bay 2
10	Hard drive bay 1

*An optional hard drive backplane is required when the server is configured with eight hard drives.

Front panel LEDs and buttons

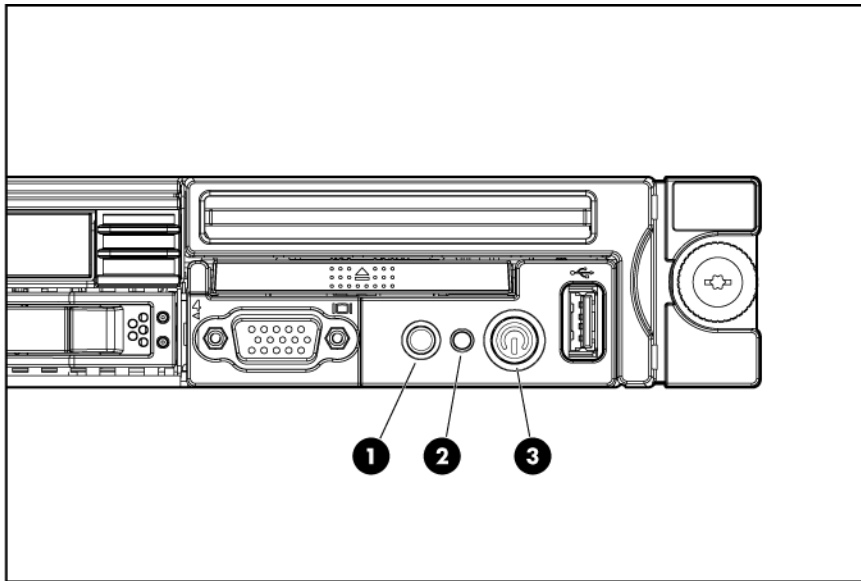

Item	Description	Status
1	UID LED/button	Blue = Identification is activated. Flashing blue = System is being managed remotely. Off = Identification is deactivated.
2	Health LED	Green = System health is normal. Amber = System health is degraded. To identify the component in a degraded state, see "Systems Insight Display LEDs (on page 13)". Red = System health is critical. To identify the component in a critical state, see "Systems Insight Display LEDs (on page 13)". Off = System health is normal (when in standby mode).
3	Power On/Standby button and system power LED	Green = System is on. Amber = System is in standby, but power is still applied. Off = Power cord is not attached, power supply failure has occurred, no power supplies are installed, facility power is not available, or the power button cable is disconnected.

Rear panel components

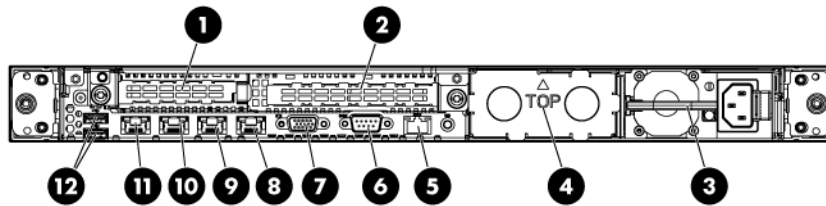

Item	Description
1	Slot 1 PCIe2 x8 (8, 4, 2, 1)
2	Slot 2 PCIe2 x16 (16, 8, 4, 2, 1), 75W +EXT 75W*
3	Power supply bay 1 (populated)
4	Power supply bay 2
5	iLO 3 connector
6	Serial connector
7	Video connector
8	NIC 4 connector
9	NIC 3 connector
10	NIC 2 connector
11	NIC 1 connector
12	USB connectors (2)

*This expansion slot provides 75 W of power to an adapter, with an additional 75 W of power supplied by external power.

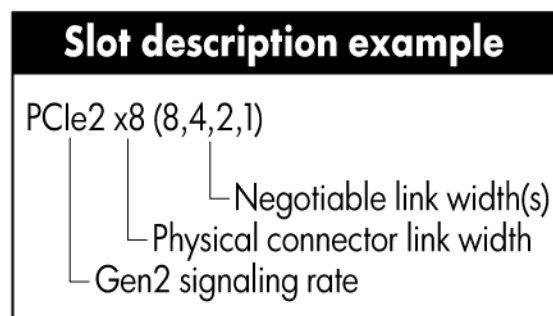

Rear panel LEDs and buttons

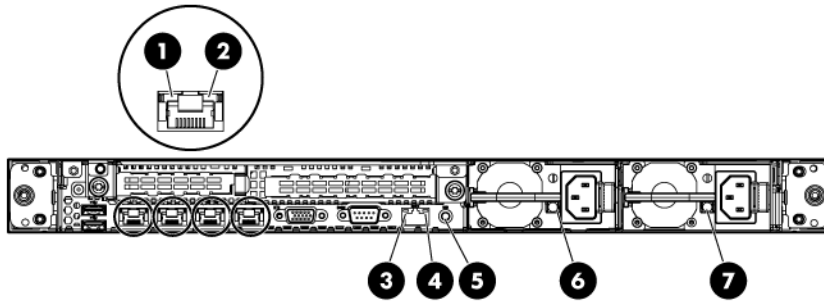

Item	Description	Status
1	10/100/1000 NIC activity LED	Green = Activity exists. Flashing green = Activity exists. Off = No activity exists.
2	10/100/1000 NIC link LED	Green = Link exists. Off = No link exists.
3	iLO 3 NIC activity LED	Green = Activity exists. Flashing green = Activity exists. Off = No activity exists.
4	iLO 3 NIC link LED	Green = Link exists. Off = No link exists.
5	UID button/LED	Blue = Identification is activated. Flashing blue = System is being managed remotely. Off = Identification is deactivated.
6	Power supply 2 LED	Green = Normal Off = One or more of the following conditions exists: <ul style="list-style-type: none"> • AC power unavailable • Power supply failed • Power supply in standby mode • Power supply exceeded current limit
7	Power supply 1 LED	Green = Normal Off = One or more of the following conditions exists: <ul style="list-style-type: none"> • AC power unavailable • Power supply failed • Power supply in standby mode • Power supply exceeded current limit

System board components

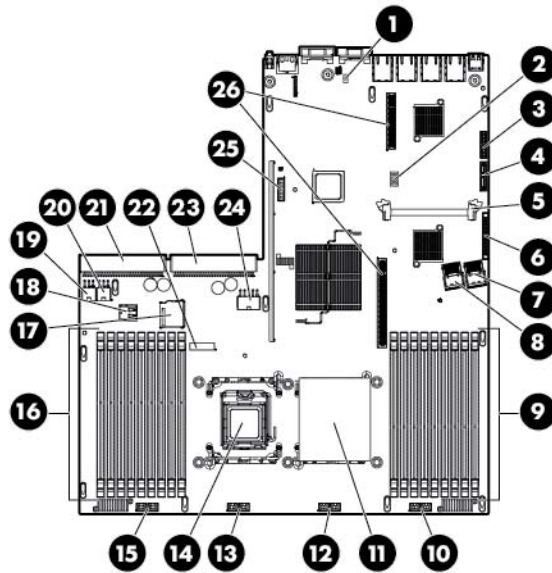

Item	Description
1	NMI jumper
2	System maintenance switch
3	10Gb sideband connector
4	SATA DVD-ROM drive connector
5	SAS cache module connector
6	Power button connector
7	Hard drive data connector 1 (drives 1–4)
8	Hard drive data connector 2 (drives 5–8)
9	Processor 1 DIMM slots (9)
10	Fan module 4 connector
11	Processor socket 1 (populated)
12	Fan module 3 connector
13	Fan module 2 connector
14	Processor socket 2
15	Fan module 1 connector
16	Processor 2 DIMM slots (9)
17	SD card slot
18	Internal USB connector
19	Hard drive power connector 1
20	Hard drive power connector 2
21	Power supply connector 1
22	System battery

Item	Description
23	Power supply connector 2
24	PCI power connector
25	TPM connector
26	PCIe riser board connectors (2)

DIMM slots

DIMM slots are numbered sequentially (1 through 9) for each processor. The supported AMP modes use the letter assignments for population guidelines.

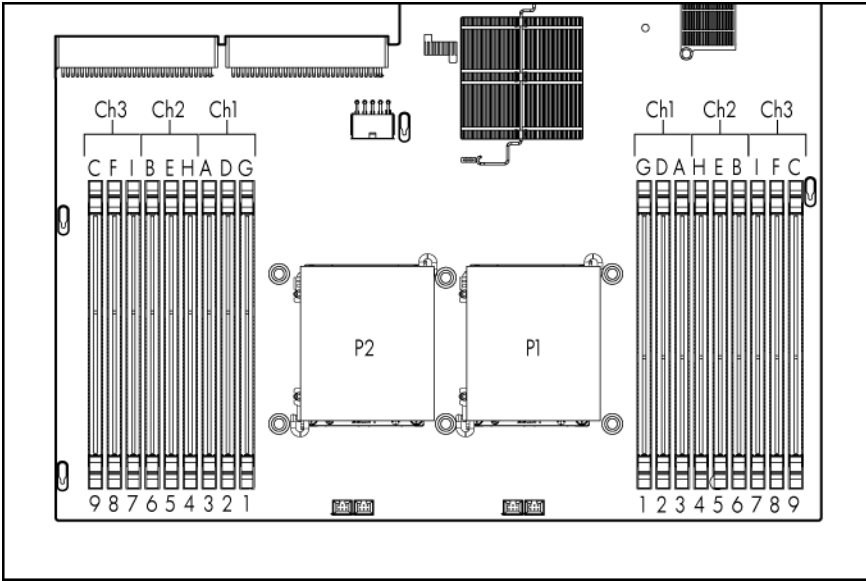

System maintenance switch

Position	Default	Function
S1	Off	Off = iLO 3 security is enabled. On = iLO 3 security is disabled.
S2	Off	Off = System configuration can be changed. On = System configuration is locked.
S3	Off	Reserved
S4	Off	Reserved
S5	Off	Off = Power-on password is enabled. On = Power-on password is disabled.
S6	Off	Off = No function On = Clear NVRAM
S7	—	Reserved

Position	Default	Function
S8	—	Reserved
S9	—	Reserved
S10	—	Reserved

When the system maintenance switch position 6 is set to the On position, the system is prepared to erase all system configuration settings from both CMOS and NVRAM.

CAUTION: Clearing CMOS and/or NVRAM deletes configuration information. Be sure to properly configure the server or data loss could occur.

NMI jumper

The NMI jumper allows administrators to perform a memory dump before performing a hard reset. Crash dump analysis is an essential part of eliminating reliability problems, such as hangs or crashes in OSs, device drivers, and applications. Many crashes can freeze a system, requiring you to do a hard reset. Resetting the system erases any information that would support root cause analysis.

Systems running Microsoft® Windows® experience a blue-screen trap when the OS crashes. When this happens, Microsoft® recommends that system administrators perform an NMI event by temporarily shorting the NMI header with a jumper. The NMI event enables a hung system to become responsive again.

Systems Insight Display LEDs

The HP Systems Insight Display LEDs represent the system board layout. The display provides status for all internal LEDs and enables diagnosis with the access panel installed. To view the LEDs, access the HP Systems Insight Display (on page 20).

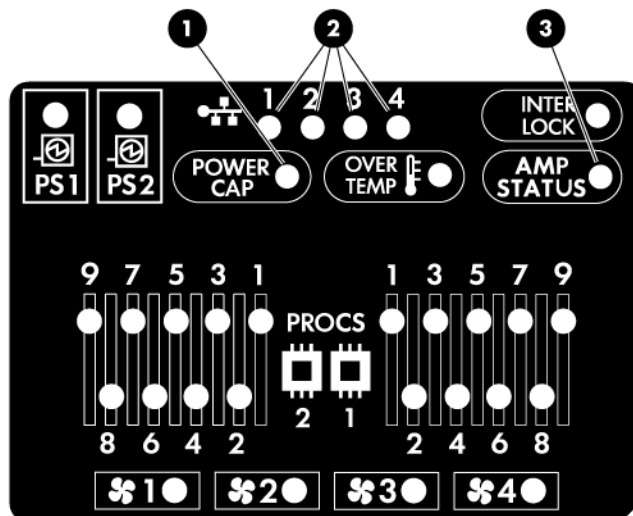

Item	Description	Status
1	Power cap LED	To determine Power cap status, see "Systems Insight Display LED combinations (on page 14)."
2	NIC LEDs	Green = Network link exists. Flashing green = Network link and activity exist. Off = No link to network exists. If power is off, the front panel LED is not active. For status, see "Rear panel LEDs and buttons (on page 10)."
3	AMP status	Green = AMP mode enabled Amber = Failover Flashing amber = Invalid configuration Off = AMP mode disabled
—	All other LEDs	Amber = Failure Off = Normal For possible failure causes, see "Systems Insight Display LED combinations (on page 14)."

Systems Insight Display LED combinations

When the health LED on the front panel illuminates either amber or red, the server is experiencing a health event. Combinations of illuminated Systems Insight Display LEDs, the system power LED, and the health LED indicate system status.

Systems Insight Display LED and color	Health LED	System power LED	Status
Processor (amber)	Red	Amber	One or more of the following conditions may exist: <ul style="list-style-type: none"> • Processor in socket X has failed. • Processor X is not installed in the socket. • Processor X is unsupported. • ROM detects a failed processor during POST
Processor (amber)	Amber	Green	Processor in socket X is in a pre-failure condition.
DIMM (amber)	Red	Green	One or more DIMMs have failed.
DIMM (amber)	Amber	Green	DIMM in slot X is in a pre-failure condition.
Overtemperature (amber)	Amber	Green	The Health Driver has detected a cautionary temperature level.
Overtemperature (amber)	Red	Amber	The server has detected a hardware critical temperature level.
Interlock (amber)	Red	Green	The PCI riser board assembly is not seated properly.

Systems Insight Display LED and color	Health LED	System power LED	Status
Fan (amber)	Amber	Green	One fan has failed or has been removed.
Fan (amber)	Red	Green	Two or more fans have failed or been removed.
Power supply (amber)	Red	Amber	<ul style="list-style-type: none"> Only one power supply is installed and that power supply is in standby. Power supply fault System board fault
Power supply (amber)	Amber	Green	<ul style="list-style-type: none"> Redundant power supply is installed and only one power supply is functional. AC power cord is not plugged into redundant power supply. Redundant power supply fault Power supply mismatch at POST or power supply mismatch through hot-plug addition.
Power cap (off)	—	Amber	Standby
Power cap (green)	—	Flashing green	Waiting for power
Power cap (flashing amber)	—	Amber	Power cap has been exceeded.
Power cap (green)	—	Green	Power is available.



IMPORTANT: If more than one DIMM slot LED is illuminated, further troubleshooting is required. Test each bank of DIMMs by removing all other DIMMs. Isolate the failed DIMM by replacing each DIMM in a bank with a known working DIMM.

SAS and SATA device numbers

- Four-hard drive configuration



- Eight-hard drive configuration



SAS and SATA hard drive LEDs

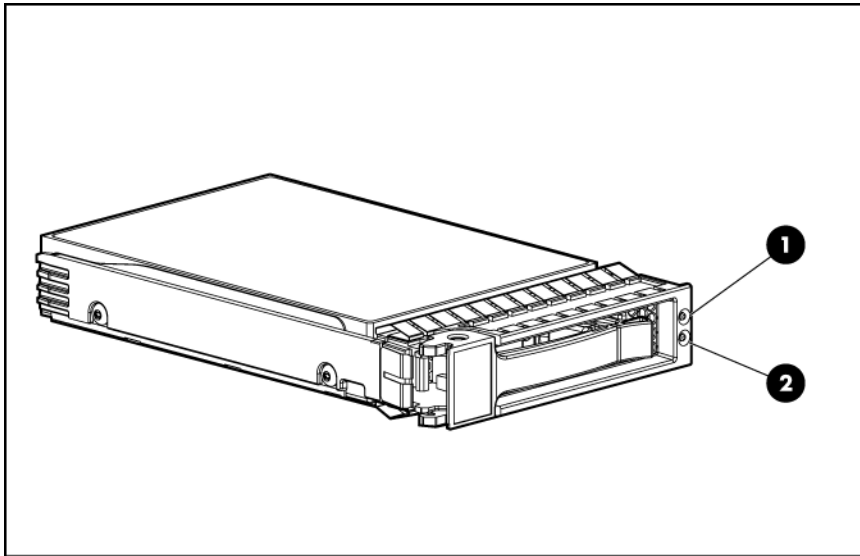

Item	Description
1	Fault/UID LED (amber/blue)
2	Online LED (green)

Fan modules

- One-processor configuration

When only one processor is installed, be sure the fan blank is always installed to ensure proper cooling.

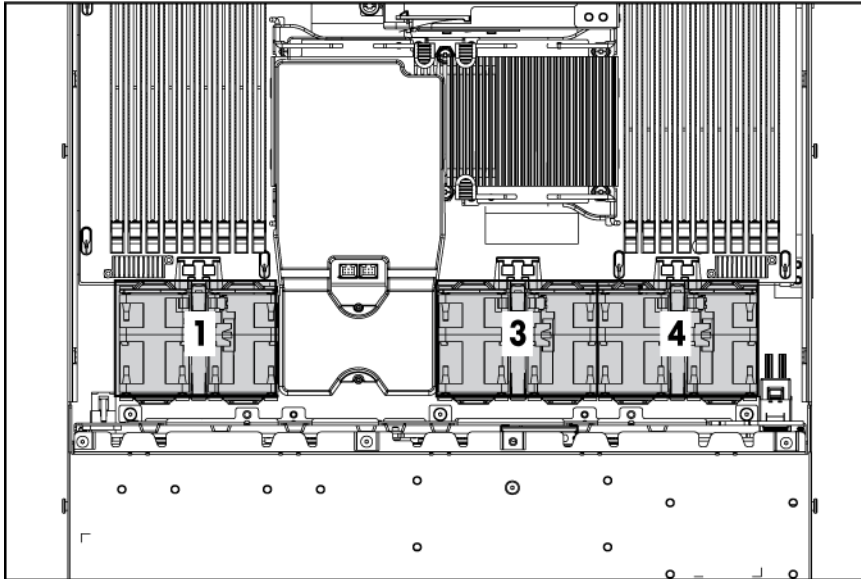

- Two-processor configuration

Install fan 2 only when processor 2 is installed. When only one processor is installed, always install the fan blank.

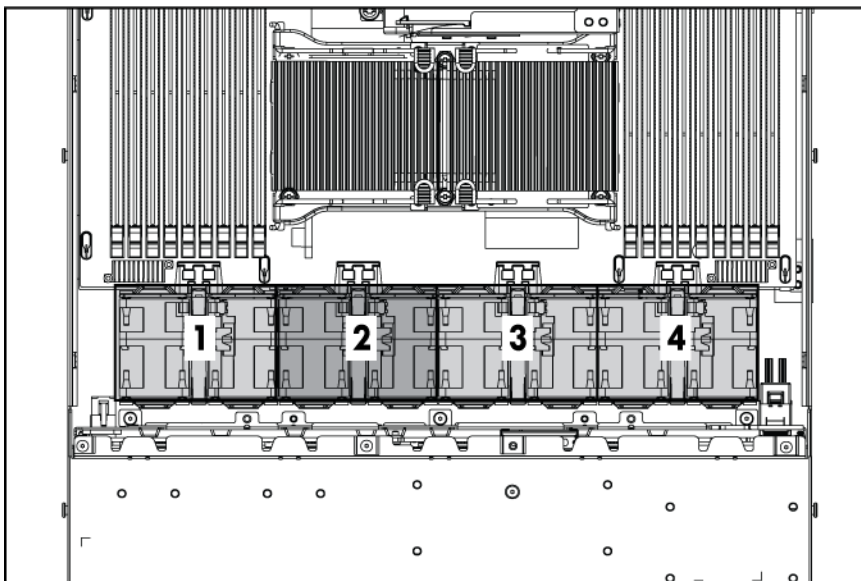

Item	Description
1	Fan module 1
2	Fan module 2
3	Fan module 3
4	Fan module 4

T-10/T-15 Torx screwdriver

The server includes a T-10/T-15 Torx screwdriver that ships on the air baffle. Use the screwdriver to loosen screws or thumbscrews, as needed, during procedures.

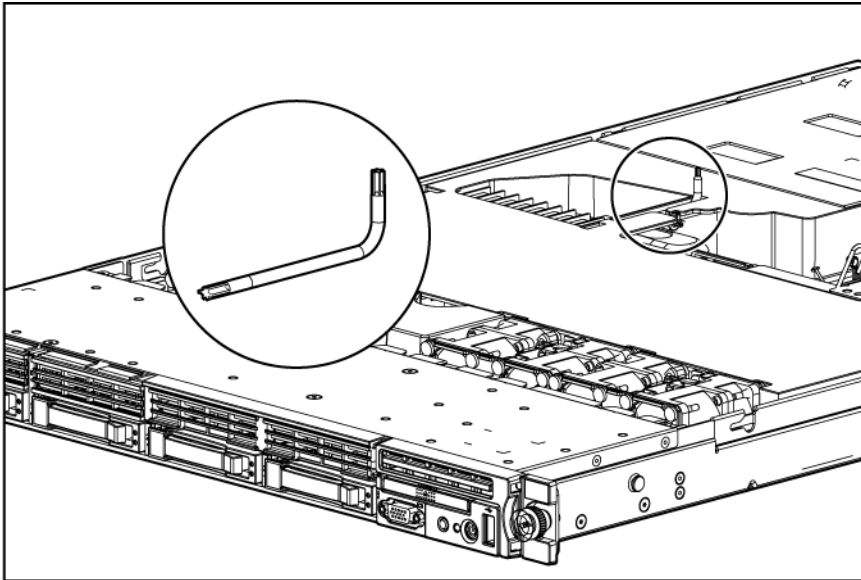

Operations

Power up the server

To power up the server, press the Power On/Standby button.

Power down the server

 **WARNING:** To reduce the risk of personal injury, electric shock, or damage to the equipment, remove the power cord to remove power from the server. The front panel Power On/Standby button does not completely shut off system power. Portions of the power supply and some internal circuitry remain active until AC power is removed.

 **IMPORTANT:** If installing a hot-plug device, it is not necessary to power down the server.

1. Back up the server data.
2. Shut down the operating system as directed by the operating system documentation.
3. If the server is installed in a rack, press the UID LED button on the front panel. Blue LEDs illuminate on the front and rear panels of the server.
4. Press the Power On/Standby button to place the server in standby mode. When the server activates standby power mode, the system power LED changes to amber.
5. If the server is installed in a rack, locate the server by identifying the illuminated rear UID LED button.
6. Disconnect the power cords.

The system is now without power.

Extend the server from the rack

NOTE: If the optional cable management arm option is installed, you can extend the server without powering down the server or disconnecting peripheral cables and power cords. These steps are only necessary with the standard cable management solution.

1. Power down the server (on page 19).
2. Disconnect all peripheral cables and power cords.
3. Loosen the front panel thumbscrews.
4. Extend the server on the rack rails until the server rail-release latches engage.

 **WARNING:** To reduce the risk of personal injury or equipment damage, be sure that the rack is adequately stabilized before extending a component from the rack.

 **WARNING:** To reduce the risk of personal injury, be careful when pressing the server rail-release latches and sliding the server into the rack. The sliding rails could pinch your fingers.

5. After performing the installation or maintenance procedure, slide the server into the rack:
 - a. Slide the server fully into the rack.
 - b. Secure the server by tightening the thumbscrews.
6. Connect the peripheral cables and power cords.

Access the HP Systems Insight Display

To eject the HP Systems Insight Display:

1. Press and release the display.
2. Extend the display from the chassis.

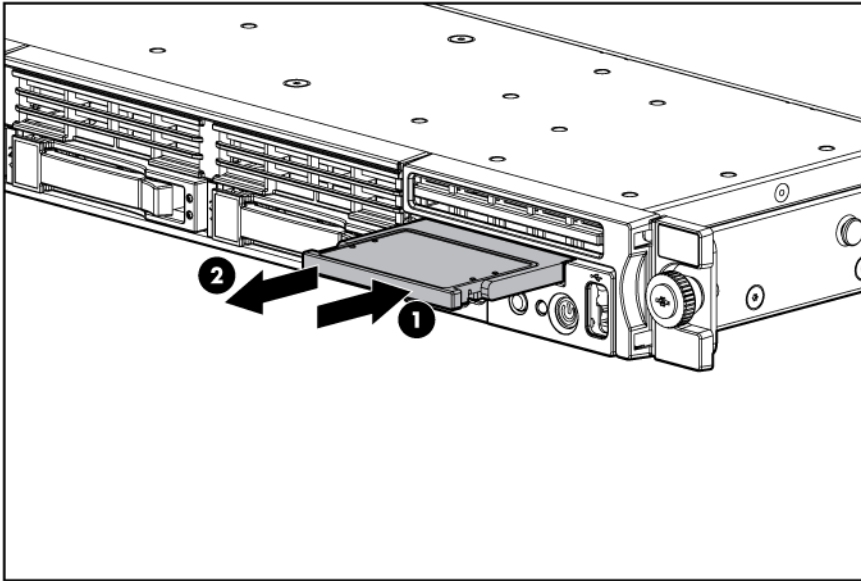

The display can be rotated up to 90 degrees.

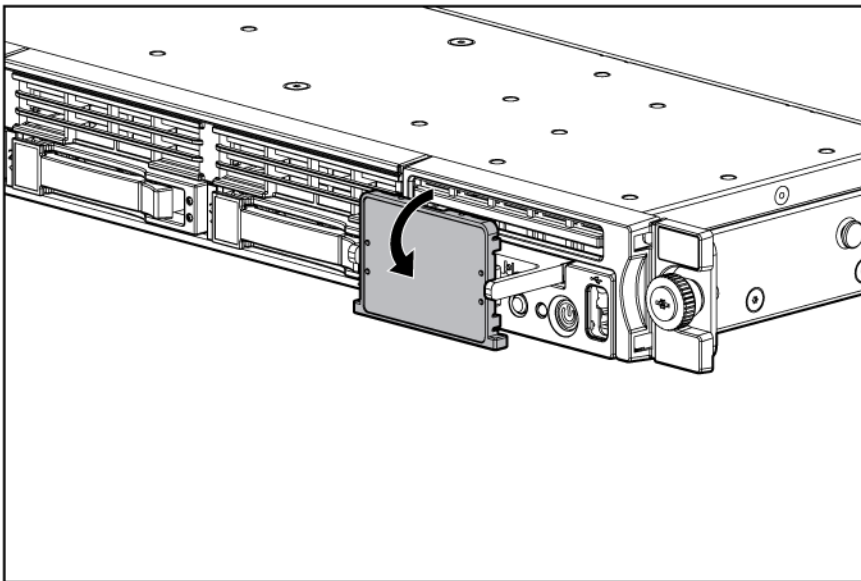

Remove the access panel

 **WARNING:** To reduce the risk of personal injury from hot surfaces, allow the drives and the internal system components to cool before touching them.

 **CAUTION:** Do not operate the server for long periods with the access panel open or removed. Operating the server in this manner results in improper airflow and improper cooling that can lead to thermal damage.

To remove the component:

1. Power down the server (on page 19).
2. Extend the server from the rack (on page 19).
3. Open the locking latch, slide the access panel to the rear of the chassis, and remove the access panel.

If the locking latch is locked use a T-15 Torx screwdriver to unlock the latch.

Install the access panel

1. Place the access panel on top of the server with the hood latch open. Allow the panel to extend past the rear of the server approximately 1.25 cm (0.5 in).
2. Push down on the hood latch. The access panel slides to a closed position.
3. Use the T-15 Torx screwdriver provided with the server to tighten the security screw on the hood latch.

Remove the BBWC battery pack or the FBWC capacitor pack

1. Power down the server (on page 19).
2. Extend the server from the rack (on page 19).
3. Remove the access panel (on page 21).

4. Remove the BBWC battery pack or the FBWC capacitor pack.

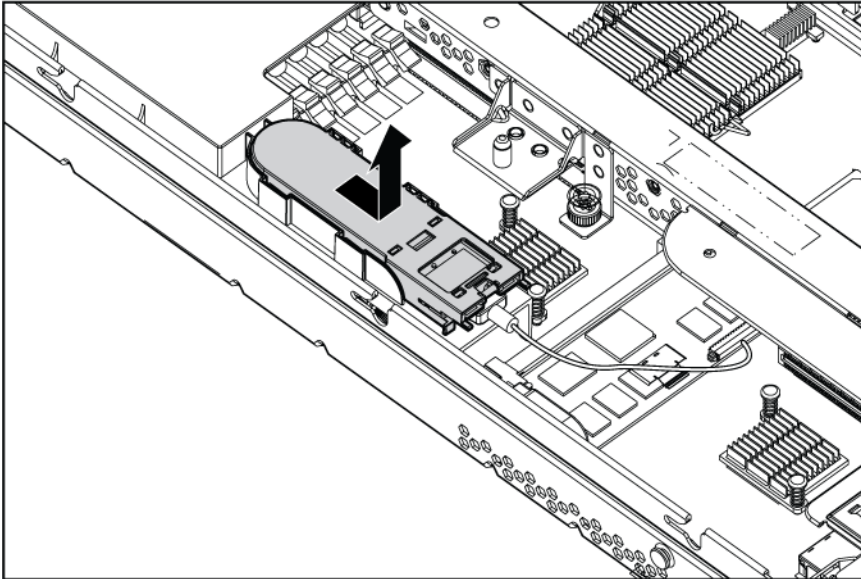

Remove the air baffle

1. Power down the server (on page 19).
2. Extend the server from the rack (on page 19).
3. Remove the access panel (on page 21).
4. If installed, remove the BBWC battery pack or the FBWC capacitor pack (on page 21).
5. Remove the air baffle.

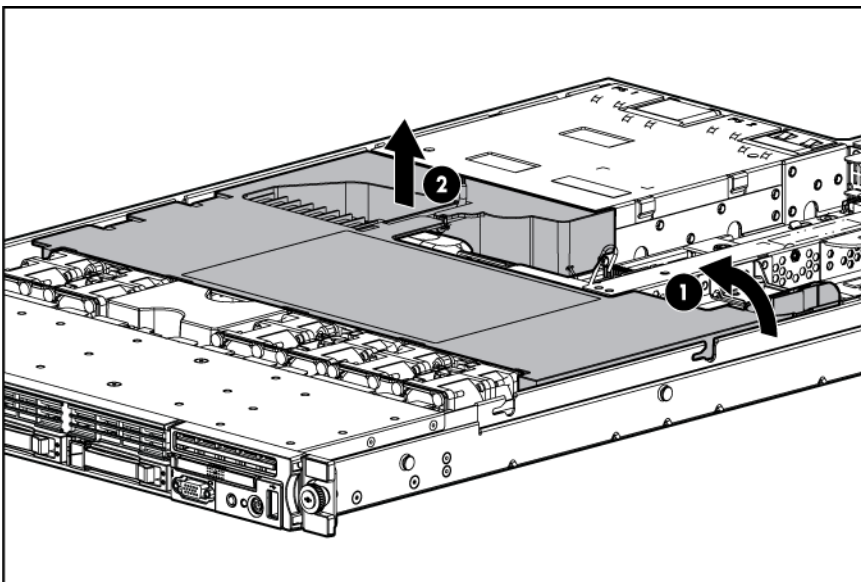

Install the air baffle

-
- CAUTION:** For proper cooling do not operate the server without the access panel, baffles, expansion slot covers, or blanks installed. If the server supports hot-plug components, minimize the amount of time the access panel is open.
-

1. Install the air baffle.

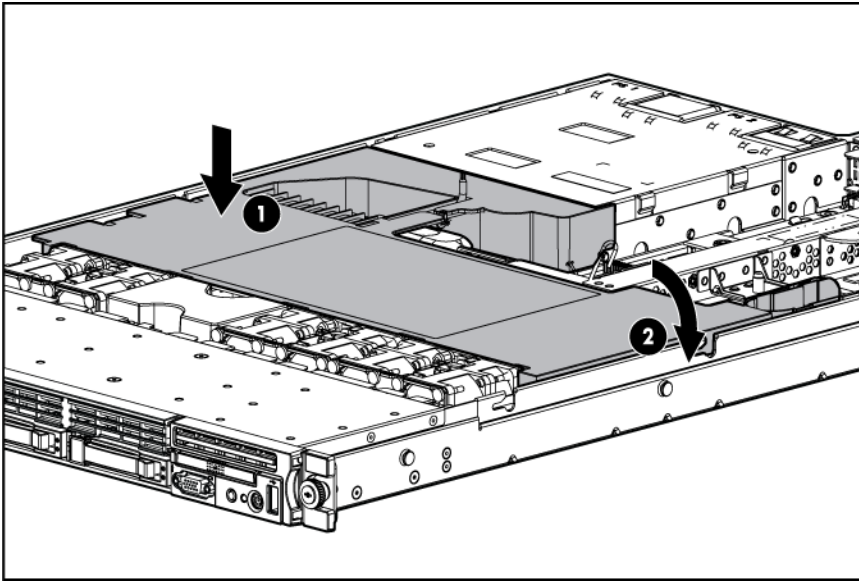

2. If removed, install the BBWC battery pack or the FBWC capacitor pack ("[Installing the BBWC battery pack or the FBWC capacitor pack](#)" on page 58).
3. Install the access panel (on page 21).
4. Slide the server into the rack.
5. Power up the server (on page 19).

Remove the PCI riser board assembly

-
- CAUTION:** To prevent damage to the server or expansion boards, power down the server and remove all AC power cords before removing or installing the PCI riser board assembly.
-

1. Power down the server (on page 19).
2. Extend the server from the rack (on page 19).
3. Remove the access panel (on page 21).
4. If installed, remove the BBWC battery pack or the FBWC capacitor pack (on page 21).
5. Remove the air baffle (on page 22).
6. Remove the PCI riser board assembly:
 - a. Disconnect external cables connected to any existing expansion boards.
 - b. Loosen the four PCI riser board assembly thumbscrews.

- c. Lift the assembly to unseat the PCI riser boards, and then remove the assembly.

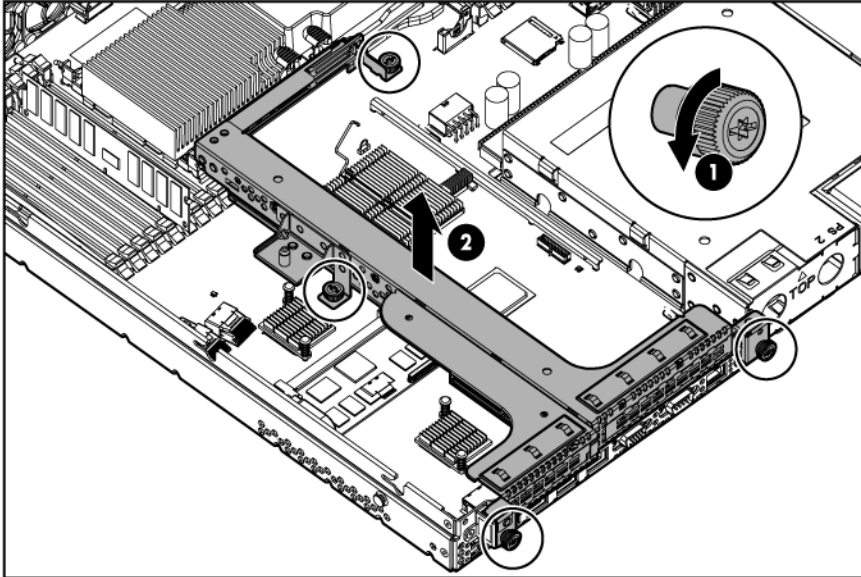

Install the PCI riser board assembly

CAUTION: To prevent damage to the server or expansion boards, power down the server and remove all AC power cords before removing or installing the PCI riser board assembly.

1. Align the PCI riser boards with the corresponding connectors on the system board, and then install the assembly.
2. Tighten the four PCI riser board assembly thumbscrews.

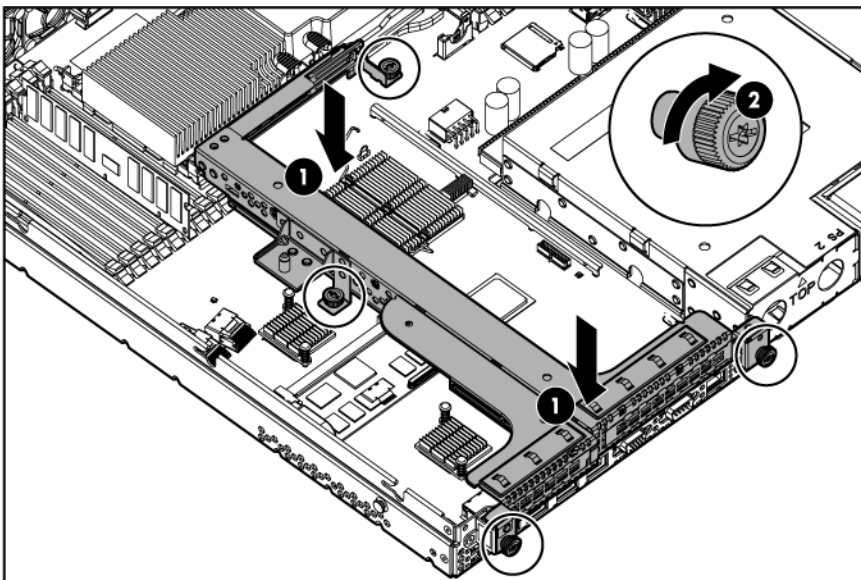

3. Install the air baffle (on page 22).
4. If removed, install the BBWC battery pack or the FBWC capacitor pack ("Installing the BBWC battery pack or the FBWC capacitor pack" on page 58).
5. Install the access panel (on page 21).
6. Slide the server into the rack.

7. Power up the server (on page 19).

Setup

Optional installation services

Delivered by experienced, certified engineers, HP Care Pack services help you keep your servers up and running with support packages tailored specifically for HP ProLiant systems. HP Care Packs let you integrate both hardware and software support into a single package. A number of service level options are available to meet your needs.

HP Care Pack Services offer upgraded service levels to expand your standard product warranty with easy-to-buy, easy-to-use support packages that help you make the most of your server investments. Some of the Care Pack services are:

- Hardware support
 - 6-Hour Call-to-Repair
 - 4-Hour 24x7 Same Day
 - 4-Hour Same Business Day
- Software support
 - Microsoft®
 - Linux
 - HP ProLiant Essentials (HP SIM and RDP)
 - VMWare
- Integrated hardware and software support
 - Critical Service
 - Proactive 24
 - Support Plus
 - Support Plus 24
- Startup and implementation services for both hardware and software

For more information on HP Care Pack Services, see the HP website (<http://www.hp.com/services/carepack>).

Rack planning resources

The rack resource kit ships with all HP branded or Compaq branded 9000, 10000, and H9 series racks. For more information on the content of each resource, refer to the rack resource kit documentation.

If you intend to deploy and configure multiple servers in a single rack, refer to the white paper on high-density deployment at the HP website (<http://www.hp.com/products/servers/platforms>).

Optimum environment

When installing the server in a rack, select a location that meets the environmental standards described in this section.

Space and airflow requirements

To allow for servicing and adequate airflow, observe the following space and airflow requirements when deciding where to install a rack:

- Leave a minimum clearance of 63.5 cm (25 in) in front of the rack.
- Leave a minimum clearance of 76.2 cm (30 in) behind the rack.
- Leave a minimum clearance of 121.9 cm (48 in) from the back of the rack to the back of another rack or row of racks.

HP servers draw in cool air through the front door and expel warm air through the rear door. Therefore, the front and rear rack doors must be adequately ventilated to allow ambient room air to enter the cabinet, and the rear door must be adequately ventilated to allow the warm air to escape from the cabinet.

 **CAUTION:** To prevent improper cooling and damage to the equipment, do not block the ventilation openings.

When vertical space in the rack is not filled by a server or rack component, the gaps between the components cause changes in airflow through the rack and across the servers. Cover all gaps with blanking panels to maintain proper airflow.

 **CAUTION:** Always use blanking panels to fill empty vertical spaces in the rack. This arrangement ensures proper airflow. Using a rack without blanking panels results in improper cooling that can lead to thermal damage.

The 9000 and 10000 Series Racks provide proper server cooling from flow-through perforations in the front and rear doors that provide 64 percent open area for ventilation.

 **CAUTION:** When using a Compaq branded 7000 Series rack, you must install the high airflow rack door insert [P/N 327281-B21 (42U) or P/N 157847-B21 (22U)] to provide proper front-to-back airflow and cooling.

 **CAUTION:** If a third-party rack is used, observe the following additional requirements to ensure adequate airflow and to prevent damage to the equipment:

- Front and rear doors—If the 42U rack includes closing front and rear doors, you must allow 5,350 sq cm (830 sq in) of holes evenly distributed from top to bottom to permit adequate airflow (equivalent to the required 64 percent open area for ventilation).
- Side—The clearance between the installed rack component and the side panels of the rack must be a minimum of 7 cm (2.75 in).

Temperature requirements

To ensure continued safe and reliable equipment operation, install or position the system in a well-ventilated, climate-controlled environment.

The maximum recommended ambient operating temperature (TMRA) for most server products is 35°C (95°F). The temperature in the room where the rack is located must not exceed 35°C (95°F).

-
-  **CAUTION:** To reduce the risk of damage to the equipment when installing third-party options:
- Do not permit optional equipment to impede airflow around the server or to increase the internal rack temperature beyond the maximum allowable limits.
 - Do not exceed the manufacturer's TMRA.
-

Power requirements

Installation of this equipment must comply with local and regional electrical regulations governing the installation of information technology equipment by licensed electricians. This equipment is designed to operate in installations covered by NFPA 70, 1999 Edition (National Electric Code) and NFPA-75, 1992 (code for Protection of Electronic Computer/Data Processing Equipment). For electrical power ratings on options, refer to the product rating label or the user documentation supplied with that option.

-
-  **WARNING:** To reduce the risk of personal injury, fire, or damage to the equipment, do not overload the AC supply branch circuit that provides power to the rack. Consult the electrical authority having jurisdiction over wiring and installation requirements of your facility.
-

-  **CAUTION:** Protect the server from power fluctuations and temporary interruptions with a regulating uninterruptible power supply (UPS). This device protects the hardware from damage caused by power surges and voltage spikes and keeps the system in operation during a power failure.
-

When installing more than one server, you may need to use additional power distribution devices to safely provide power to all devices. Observe the following guidelines:

- Balance the server power load between available AC supply branch circuits.
- Do not allow the overall system AC current load to exceed 80 percent of the branch circuit AC current rating.
- Do not use common power outlet strips for this equipment.
- Provide a separate electrical circuit for the server.

For more information on the hot-plug power supply and calculators to determine server power consumption in various system configurations, refer to the HP Enterprise Configurator website (<http://h30099.www3.hp.com/configurator/>).

Electrical grounding requirements

The server must be grounded properly for proper operation and safety. In the United States, you must install the equipment in accordance with NFPA 70, 1999 Edition (National Electric Code), Article 250, as well as any local and regional building codes. In Canada, you must install the equipment in accordance with Canadian Standards Association, CSA C22.1, Canadian Electrical Code. In all other countries, you must install the equipment in accordance with any regional or national electrical wiring codes, such as the International Electrotechnical Commission (IEC) Code 364, parts 1 through 7. Furthermore, you must be sure that all power distribution devices used in the installation, such as branch wiring and receptacles, are listed or certified grounding-type devices.

Because of the high ground-leakage currents associated with multiple servers connected to the same power source, HP recommends the use of a PDU that is either permanently wired to the building's branch

circuit or includes a nondetachable cord that is wired to an industrial-style plug. NEMA locking-style plugs or those complying with IEC 60309 are considered suitable for this purpose. Using common power outlet strips for the server is not recommended.

Rack warnings



WARNING: To reduce the risk of personal injury or damage to the equipment, be sure that:

- The leveling jacks are extended to the floor.
- The full weight of the rack rests on the leveling jacks.
- The stabilizing feet are attached to the rack if it is a single-rack installation.
- The racks are coupled together in multiple-rack installations.
- Only one component is extended at a time. A rack may become unstable if more than one component is extended for any reason.



WARNING: To reduce the risk of personal injury or equipment damage when unloading a rack:

- At least two people are needed to safely unload the rack from the pallet. An empty 42U rack can weigh as much as 115 kg (253 lb), can stand more than 2.1 m (7 ft) tall, and may become unstable when being moved on its casters.
- Never stand in front of the rack when it is rolling down the ramp from the pallet. Always handle the rack from both sides.

Contents of the server shipping carton

Unpack the server shipping carton and locate the materials and documentation necessary for installing the server. All the rack mounting hardware necessary for installing the server into the rack is included with the rack or the server.

The contents of the server shipping carton include:

- Server
- Power cord
- Printed setup documentation, Documentation CD, and software products
- Rack mounting hardware kit and documentation

In addition to these supplied items, you may need:

- T-10/T-15 Torx screwdriver (on page 18)
- Hardware options
- Operating system or application software

Installing hardware options

Install any hardware options before initializing the server. For options installation information, refer to the option documentation. For server-specific information, refer to "Hardware options installation (on page 33)."

Installing the server into the rack

To install the server into a rack with square, round, or threaded holes, refer to the instructions that ship with the rack hardware kit.

If you are installing the server into a telco rack, order the appropriate option kit at the RackSolutions.com website (<http://www.racksolutions.com/hp>). Follow the server-specific instructions on the website to install the rack brackets.

Use the following information when connecting peripheral cables and power cords to the server.

- ⚠ WARNING:** This server is very heavy. To reduce the risk of personal injury or damage to the equipment:
- Observe local occupational health and safety requirements and guidelines for manual material handling.
 - Get help to lift and stabilize the product during installation or removal, especially when the product is not fastened to the rails. When the server weighs more than 22.5 kg (50 lb), at least two people must lift the server into the rack together. A third person may be required to help align the server if the server is installed higher than chest level.
 - Use caution when installing the server in or removing the server from the rack; it is unstable when not fastened to the rails.

- ⚠ CAUTION:** Always plan the rack installation so that the heaviest item is on the bottom of the rack. Install the heaviest item first, and continue to populate the rack from the bottom to the top.

1. Install the server and cable management arm into the rack. See the installation instructions that ship with the HP 1U Quick Deploy Rail System.
2. Connect the peripheral devices to the server.

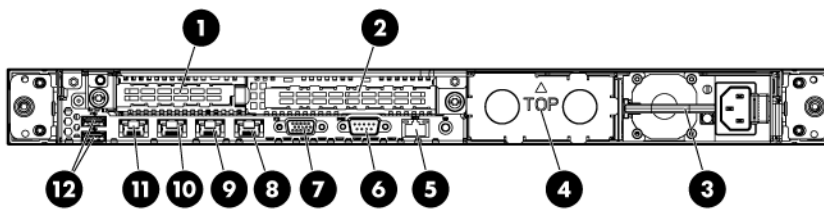

Item	Description
1	Slot 1 PCIe2 x8 (8, 4, 2, 1)
2	Slot 2 PCIe2 x16 (16, 8, 4, 2, 1), 75W +EXT 75W*
3	Power supply bay 1 (populated)
4	Power supply bay 2
5	iLO 3 connector
6	Serial connector
7	Video connector

Item	Description
8	NIC 4 connector
9	NIC 3 connector
10	NIC 2 connector
11	NIC 1 connector
12	USB connectors (2)

*This expansion slot provides 75 W of power to an adapter, with an additional 75 W of power supplied by external power.

3. Connect the power cord to the server.
4. Use the strain relief clip from the server hardware kit to secure the power cord.

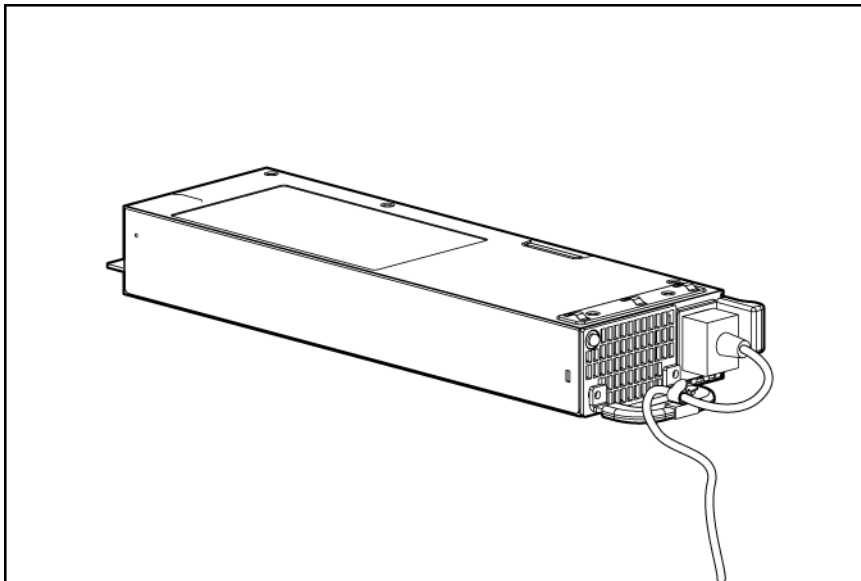

5. Connect the power cord to the power source.

Powering up and configuring the server

To power up the server, press the Power On/Standby button.

While the server boots, RBSU and the ORCA utility are automatically configured to prepare the server for operating system installation.

To configure these utilities manually:

- Press the **F8** key when prompted during the array controller initialization to configure the array controller using ORCA.
- Press the **F9** key when prompted during the boot process to change the server settings using RBSU. The system is set up by default for the English language.

For more information on the automatic configuration, refer to the *HP ROM-Based Setup Utility User Guide* located on the Documentation CD.

Installing the operating system

To operate properly, the server must have a supported operating system. For the latest information on supported operating systems, refer to the HP website (<http://www.hp.com/go/supportos>).

Two methods are available to install an operating system on the server:

- SmartStart assisted installation—Insert the SmartStart CD into the CD-ROM drive and reboot the server.
- Manual installation—Insert the operating system CD into the CD-ROM drive and reboot the server. This process may require you to obtain additional drivers from the HP website (<http://www.hp.com/support>).

Follow the on-screen instructions to begin the installation process.

For information on using these installation paths, refer to the SmartStart installation poster in the HP ProLiant Essentials Foundation Pack, included with the server.

Registering the server

To register the server, refer to the HP Registration website (<http://register.hp.com>).

Hardware options installation

Introduction

If more than one option is being installed, read the installation instructions for all the hardware options and identify similar steps to streamline the installation process.

 **WARNING:** To reduce the risk of personal injury from hot surfaces, allow the drives and the internal system components to cool before touching them.

 **CAUTION:** To prevent damage to electrical components, properly ground the server before beginning any installation procedure. Improper grounding can cause electrostatic discharge.

Processor and fan module option

Install fan 2 only when processor 2 is installed. When only one processor is installed, always install the fan blank.

To install the component:

1. Update the system ROM.
Locate and download the latest ROM version from the HP website (<http://www.hp.com/support>). Follow the instructions on the website to update the system ROM.
2. Power down the server (on page 19).
3. Extend the server from the rack (on page 19).
4. Remove the access panel (on page 21).
5. If installed, remove the BBWC battery pack or the FBWC capacitor pack (on page 21).
6. Remove the air baffle (on page 22).

7. Remove the fan blank.

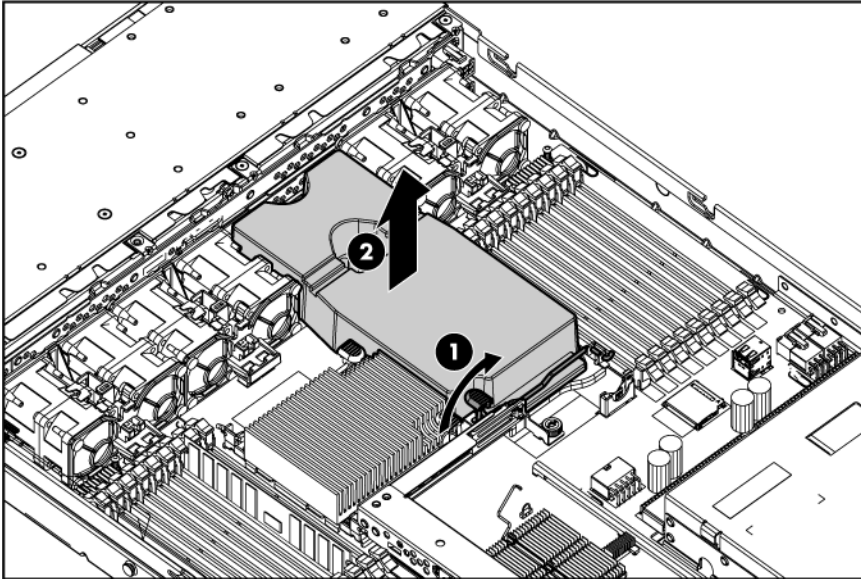

8. Install fan modules 3 and 4.

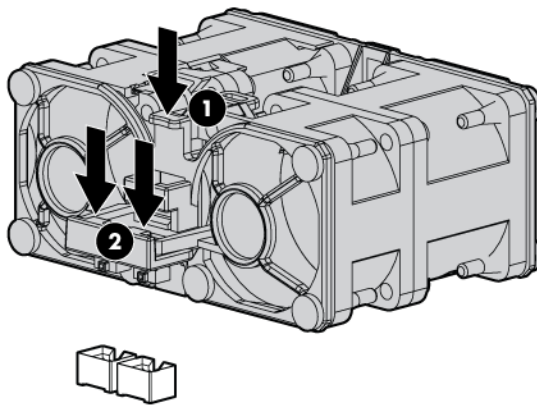

9. Open the processor retaining latch and the processor socket retaining bracket.

10. Remove the processor socket protective cover.

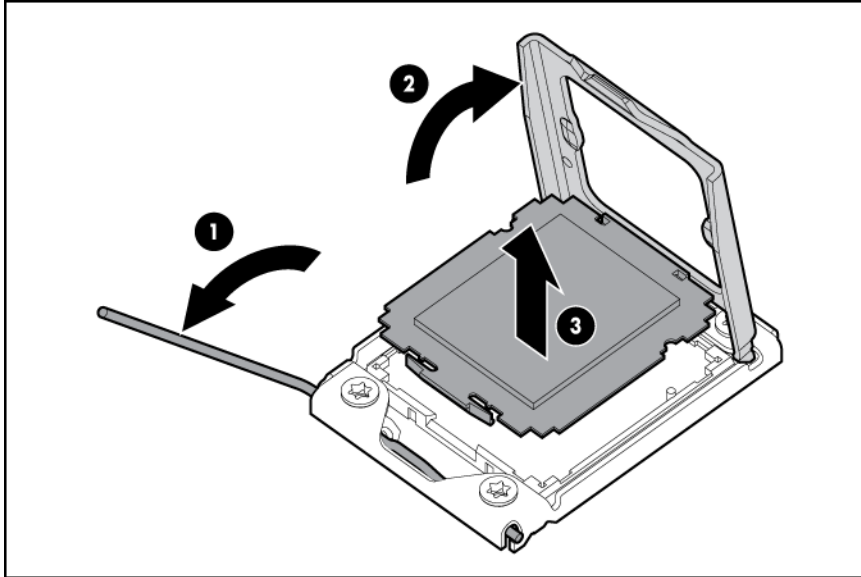

IMPORTANT: Be sure the processor remains inside the processor installation tool.

11. If the processor has separated from the installation tool, carefully re-insert the processor in the tool.

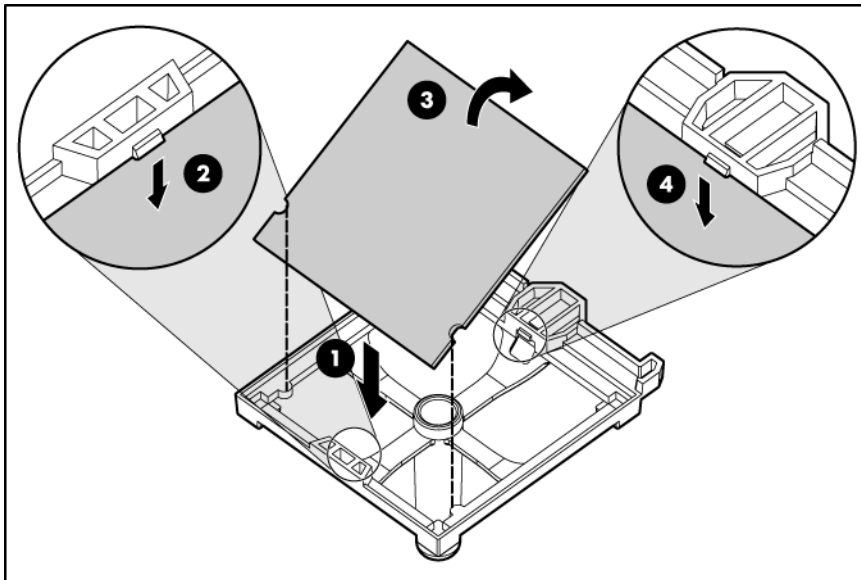

12. Align the processor installation tool with the socket and install the processor.

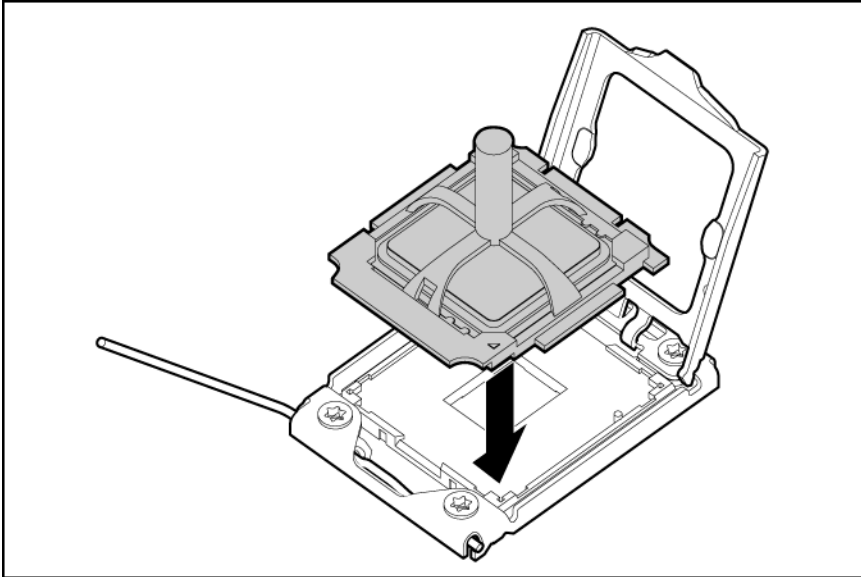

13. Press down firmly until the processor installation tool clicks and separates from the processor, and then remove the processor installation tool.

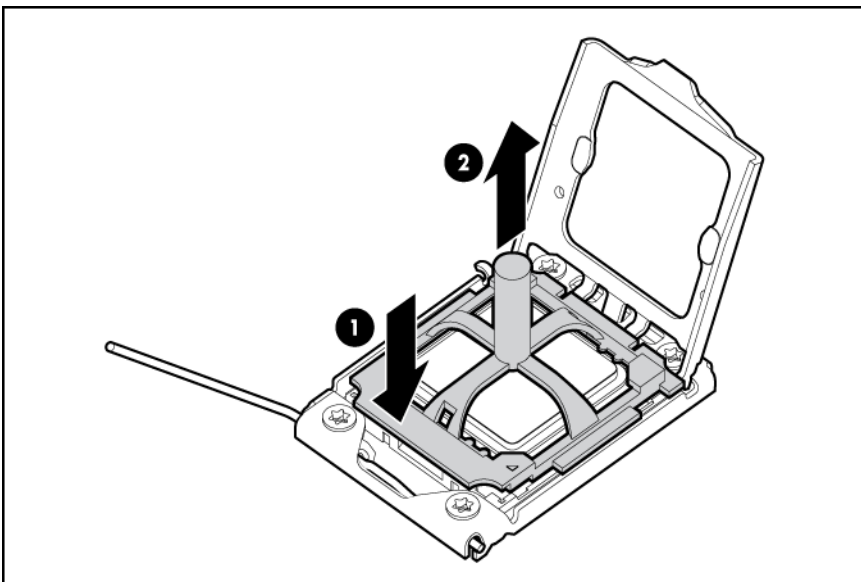

14. Close the processor socket retaining bracket and the processor retaining latch.

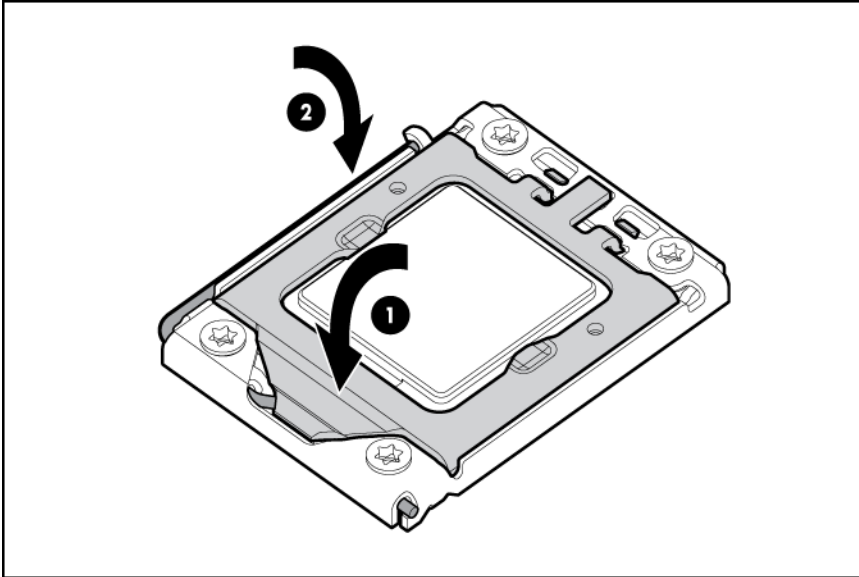

15. Remove the thermal interface media protective cover.

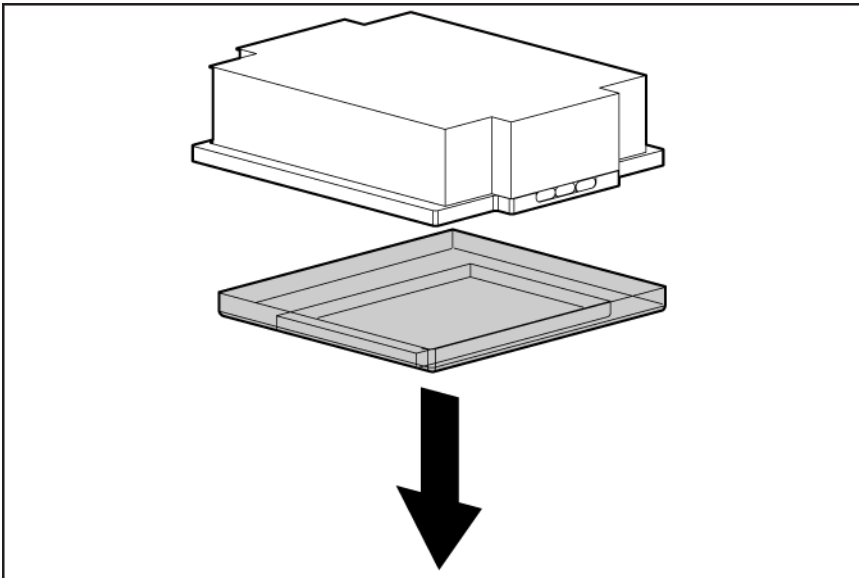

16. Install the heatsink.

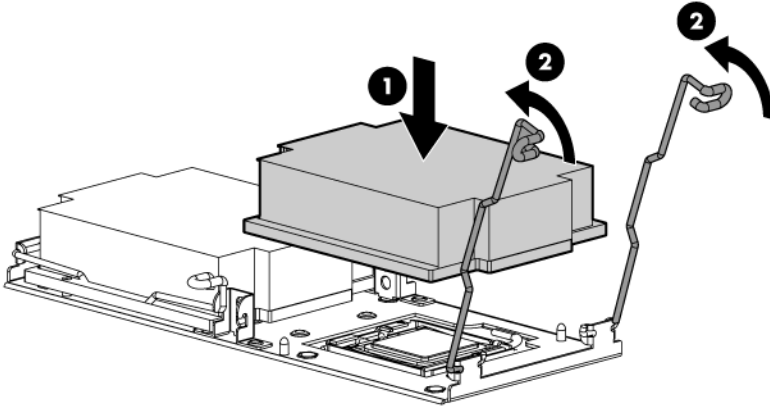

17. Install the air baffle (on page 22).
18. If removed, install the BBWC battery pack or the FBWC capacitor pack ("Installing the BBWC battery pack or the FBWC capacitor pack" on page 58).
19. Install the access panel (on page 21).
20. Slide the server into the rack.
21. Power up the server (on page 19).

Memory options



IMPORTANT: This server does not support mixing RDIMMs and UDIMMs. Attempting to mix these two types causes the server to halt during BIOS initialization.

The memory subsystem in this server can support RDIMMs or UDIMMs. Both types are referred to as DIMMs when the information applies to both types. When specified as RDIMM or UDIMM, the information applies to that type only. All memory installed in the server must be the same type.

The server supports the following DIMM speeds:

- Single- and dual-rank PC3-10600 (DDR-1333) DIMMs operating at 1333 and 1066 MHz
- Quad-rank PC3-8500 (DDR-1067) DIMMs operating at 1066 MHz

Depending on the processor model, the number of DIMMs installed, and whether UDIMMs or RDIMMs are installed, the memory clock speed may be reduced to 1066 or 800 MHz. For more information on the effect of DIMM slot population, see "General DIMM slot population guidelines (on page 42)."

Memory subsystem architecture

The memory subsystem in this server is divided into channels. Each processor supports three channels, and each channel supports three DIMM slots, as shown in the following table.

Channel	Population order	Slot number
1	G	1
	D	2
	A	3
2	H	4
	E	5
	B	6
3	I	7
	F	8
	C	9

This multi-channel architecture provides enhanced performance in Advanced ECC mode. This architecture also enables the Lockstep, Online Spare, and Mirrored Memory modes. This server supports both Registered PC3 DIMMs (RDIMMs) and Unbuffered DIMMs (UDIMMs).

DIMM slots in this server are identified by number and by letter. Letters identify the slots to populate for specific AMP modes. Slot numbers are reported by ROM messages during boot and for error reporting.

Single-, dual-, and quad-rank DIMMs

To understand and configure memory protection modes properly, an understanding of single-, dual-, and quad-rank DIMMs is helpful. Some DIMM configuration requirements are based on these classifications.

A single-rank DIMM has one set of memory chips that is accessed while writing to or reading from the memory. A dual-rank DIMM is similar to having two single-rank DIMMs on the same module, with only one rank accessible at a time. A quad-rank DIMM is, effectively, two dual-rank DIMMs on the same module. Only one rank is accessible at a time. The server memory control subsystem selects the proper rank within the DIMM when writing to or reading from the DIMM.

Dual- and quad-rank DIMMs provide the greatest capacity with the existing memory technology. For example, if current DRAM technology supports 2-GB single-rank DIMMs, a dual-rank DIMM would be 4-GB, and a quad-rank DIMM would be 8-GB.

DIMM identification



IMPORTANT: This server does not support mixing RDIMMs and UDIMMs. Attempting to mix these two types causes the server to halt during BIOS initialization.

The memory subsystem may be populated with either RDIMMs or UDIMMs, but mixing the two types is not supported. To determine DIMM characteristics, use the label attached to the DIMM and the following illustration and table.

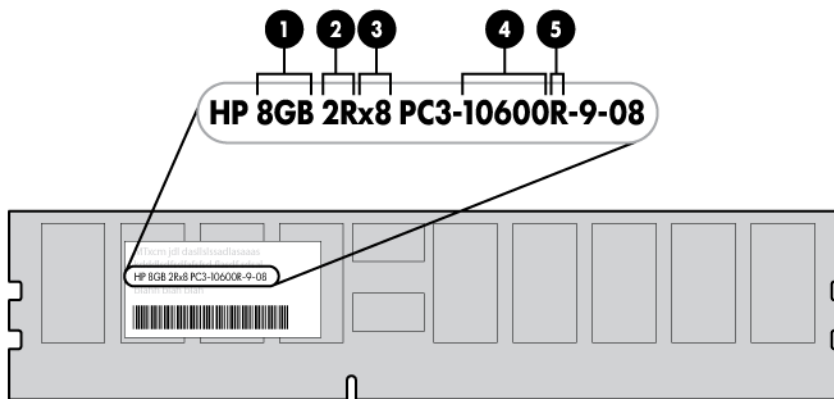

Item	Description	Definition
1	Size	—
2	Rank	1R = Single-rank 2R = Dual-rank 4R = Quad-rank
3	Data width	x4 = 4-bit x8 = 8-bit
4	Memory speed	10600 = 1333-MHz 8500 = 1066-MHz
5	DIMM type	R = RDIMM (registered) E = UDIMM (unbuffered with ECC)

For the latest supported memory information, see the QuickSpecs on the HP website (<http://www.hp.com>).

Memory configurations

To optimize server availability, the server supports the following AMP modes:

- Advanced ECC—provides the greatest memory capacity for a given DIMM size, while providing up to 4-bit error correction. This mode is the default option for this server.
- Lockstep—provides enhanced protection over Advanced ECC mode while continuing to make all installed memory available to the operating system. The server can continue to function if a single- or multi-bit memory failure within a single DRAM device occurs.
- Online spare memory—provides protection against failing or degraded DIMMs. Certain memory is reserved as spare, and automatic failover to spare memory occurs when the system detects a DIMM that is degrading and receiving a high rate of correctable memory errors. This allows DIMMs that have a higher probability of receiving an uncorrectable memory error (which would result in system downtime) to be removed from operation.

- Mirrored Memory—provides maximum protection against failed DIMMs. Uncorrectable errors in one channel are corrected by the mirror channel.

Advanced Memory Protection options are configured in RBSU. If the requested AMP mode is not supported by the installed DIMM configuration, the server boots in Advanced ECC mode. For more information, see "HP ROM-Based Setup Utility (on page 74)."

For the latest memory configuration information, see the QuickSpecs on the HP website (<http://www.hp.com>).

RDIMM maximum memory configurations

The following table lists the maximum memory configurations possible with 16-GB RDIMMs.

Rank	Single-processor	Dual-processor
Single-rank	36 GB	72 GB
Dual-rank	72 GB	144 GB
Quad-rank	96 GB	192 GB

UDIMM maximum memory configurations

The server supports a maximum of 24 GB with one processor and 48 GB with two processors using 4-GB single- or dual-rank UDIMMs.

Advanced ECC memory configuration

Advanced ECC memory is the default memory protection mode for this server. Standard ECC can correct single-bit memory errors and detect multi-bit memory errors. When multi-bit errors are detected using Standard ECC, the error is signaled to the server and causes the server to halt.

Advanced ECC protects the server against some multi-bit memory errors. Advanced ECC can correct both single-bit memory errors and 4-bit memory errors if all failed bits are on the same DRAM device on the DIMM.

Advanced ECC provides additional protection over Standard ECC because it is possible to correct certain memory errors that would otherwise be uncorrected and result in a server failure. The server provides notification that correctable error events have exceeded a pre-defined threshold rate.

Lockstep memory configuration

Lockstep mode provides protection against multi-bit memory errors that occur on the same DRAM device. Lockstep mode can correct any single DRAM device failure on x4 and x8 DIMM types. The DIMMs in each channel must have identical HP part numbers.

Lockstep mode uses channel 1 and channel 2. Channel 3 is not populated. Because channel 3 cannot be populated when using Lockstep mode, the maximum memory capacity is lower than Advanced ECC mode. Memory performance with Advanced ECC is also slightly higher.

Online Spare memory configuration

Online spare memory provides protection against degraded DIMMs by reducing the likelihood of uncorrected memory errors. This protection is available without any operating system support.

Online spare memory protection dedicates one rank of each memory channel for use as spare memory. The remaining ranks are available for OS and application use. If correctable memory errors occur at a rate higher than a specific threshold on any of the non-spare ranks, the server automatically copies the memory contents of the degraded rank to the online spare rank. The server then deactivates the failing rank and automatically switches over to the online spare rank.

Mirrored memory configuration

Mirroring provides protection against uncorrected memory errors that would otherwise result in server downtime. Mirroring is performed at the channel level. Channels 1 and 2 are used; channel 3 is not populated.

Data is written to both memory channels. Data is read from one of the two memory channels. If an uncorrectable error is detected in the active memory channel, data is retrieved from the mirror channel. This channel becomes the new active channel, and the system disables the channel with the failed DIMM.

General DIMM slot population guidelines

Observe the following guidelines for all AMP modes:

- Populate DIMM slots for a processor only if the processor is installed.
- To maximize performance in multi-processor configurations, distribute the total memory capacity between all processors as evenly as possible.
- Do not mix Unbuffered and Registered PC3 DIMMs.
- Each channel supports up to two Unbuffered DIMMs.
- If quad-rank DIMMs are installed for a processor, a maximum of two DIMMs can be installed on each channel for that processor.
- If a channel contains quad-rank DIMMs, the quad-rank DIMM must be installed first on that channel.

DIMM speeds are supported as indicated in the following table.

Populated slots (per channel)	Rank	Speeds supported (MHz)
1	Single- or dual-rank	1333, 1066
1	Quad-rank	1066
2	Single- or dual-rank	1066
3	Single- or dual-rank	800

Advanced ECC population guidelines

For Advanced ECC mode configurations, observe the following guidelines:

- Observe the general DIMM slot population guidelines (on page 42).
- DIMMs may be installed individually.

Single-processor Advanced ECC population order

For Advanced ECC mode configurations with a single processor, populate the DIMM slots in the following order:

- RDIMM: Sequentially in alphabetical order (A through I)
- UDIMM: A through F, sequentially in alphabetical order. Do not populate DIMM slots G through I.

Multi-processor Advanced ECC population order

For Advanced ECC mode configurations with multiple processors, populate the DIMM slots for each processor in the following order:

- RDIMM: Sequentially in alphabetical order (A through I)
- UDIMM: A through F, sequentially in alphabetical order. Do not populate DIMM slots G through I.

Lockstep Memory population guidelines

For Lockstep memory mode configurations, observe the following guidelines:

- Observe the general DIMM slot population guidelines (on page [42](#)).
- Always install DIMMs in channels 1 and 2 for each installed processor.
- Do not install DIMMs in channel 3 for any processor.
- DIMM configuration on channel 1 and channel 2 of a processor must be identical.
- In multi-processor configurations, each processor must have a valid Lockstep Memory configuration.
- In multi-processor configurations, each processor may have a different valid Lockstep Memory configuration.

Single-processor Lockstep population order

For Lockstep memory mode configurations with a single processor, populate the DIMM slots in the following order:

- RDIMM
 - First: A and B
 - Next: D and E
 - Last: G and H
 - Do not populate slots C, F, or I.
- UDIMM
 - First: A and B
 - Last: D and E
 - Do not populate slots C, F, G, H, or I.

After installing the DIMMs, use RBSU to configure the system for Lockstep memory support ("[Configuring lockstep memory](#)" on page [77](#)).

Multi-processor Lockstep population order

For Lockstep memory mode configurations with multiple processors, populate the DIMM slots for each processor in the following order:

- RDIMM
 - First: A and B

- Next: D and E
- Last: G and H
- Do not populate slots C, F, or I.
- UDIMM
 - First: A and B
 - Last: D and E
 - Do not populate slots C, F, G, H, or I.

After installing the DIMMs, use RBSU to configure the system for Lockstep memory support ("[Configuring lockstep memory](#)" on page 77).

Online Spare population guidelines

For Online Spare mode configurations, observe the following guidelines:

- Observe the general DIMM slot population guidelines (on page 42).
- DIMM configuration on each channel of a processor must be identical.
- Each processor must have a valid Online Spare configuration.
- In multi-processor configurations, each processor can have a different valid Online Spare configuration.

Single-processor Online Spare population order

For Online Spare mode configurations with a single processor, populate the DIMM slots in the following order:

- RDIMM
 - First: A, B, and C
 - Next: D, E, and F
 - Last: G, H, and I
- UDIMM
 - First: A, B, and C
 - Last: D, E, and F
 - Do not populate slots G, H, and I.

After installing the DIMMs, use RBSU to configure the system for online spare memory support ("[Configuring online spare memory](#)" on page 77).

Multi-processor Online Spare population order

For Online Spare mode configurations with a multiple processors, populate the DIMM slots for each processor in the following order:

- RDIMM
 - First: A, B, and C
 - Next: D, E, and F
 - Last: G, H, and I

- UDIMM
 - First: A, B, and C
 - Last: D, E, and F
 - Do not populate slots G, H, and I.

After installing the DIMMs, use RBSU to configure the system for online spare memory support ("[Configuring online spare memory](#)" on page 77).

Mirrored Memory population guidelines

For Mirrored Memory mode configurations, observe the following guidelines:

- Observe the general DIMM slot population guidelines (on page 42).
- Always install DIMMs in channels 1 and 2 for each installed processor.
- Do not install DIMMs in channel 3 for any processor.
- DIMMs installed on channel 1 and channel 2 of an installed processor must be identical.
- In multi-processor configurations, each processor must have a valid Mirrored Memory configuration.
- In multi-processor configurations, each processor may have a different valid Mirrored Memory configuration.

Single-processor Mirrored Memory population order

For Mirrored Memory mode configurations with a single processor, populate the DIMM slots in the following order:

- RDIMM
 - First: A and B
 - Next: D and E
 - Last: G and H
 - Do not populate slots C, F, or I.
- UDIMM
 - First: A and B
 - Last: D and E
 - Do not populate slots C, F, G, H, or I.

After installing the DIMMs, use RBSU to configure the system for Mirrored Memory support ("[Configuring mirrored memory](#)" on page 77).

Multi-processor Mirrored Memory population order

For Mirrored Memory mode configurations with multiple processors, populate the DIMM slots for each processor in the following order:

- RDIMM
 - First: A and B
 - Next: D and E
 - Last: G and H

- Do not populate slots C, F, or I.
- UDIMM
 - First: A and B
 - Last: D and E
 - Do not populate slots C, F, G, H, or I.

After installing the DIMMs, use RBSU to configure the system for mirrored memory support ("[Configuring mirrored memory](#)" on page 77).

Installing a DIMM

CAUTION: To avoid damage to the hard drives, memory, and other system components, the air baffle, drive blanks, and access panel must be installed when the server is powered up.

1. Power down the server (on page 19).
2. Extend the server from the rack (on page 19).
3. Remove the access panel (on page 21).
4. If installed, remove the BBWC battery pack or the FBWC capacitor pack (on page 21).
5. Remove the air baffle (on page 22).
6. Open the DIMM slot latches.
7. Install the DIMM.

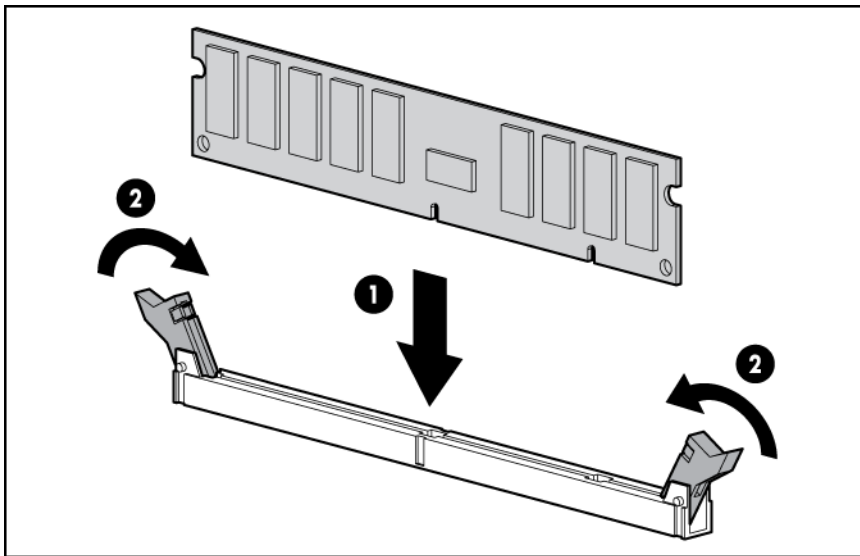

8. Install the air baffle (on page 22).
9. If removed, install the BBWC battery pack or the FBWC capacitor pack ("[Installing the BBWC battery pack or the FBWC capacitor pack](#)" on page 58).
10. Install the access panel (on page 21).

If you are installing DIMMs in online spare, mirrored, or lock-step configuration, configure this mode in RBSU ("[HP ROM-Based Setup Utility](#)" on page 74).

For more information about LEDs and troubleshooting failed DIMMs, see "Systems Insight Display LED combinations (on page 14)."

Hot-plug SAS and SATA hard drive options

When adding hard drives to the server, observe the following general guidelines:

- The system automatically sets all device numbers.
- If only one hard drive is used, install it in the bay with the lowest device number ("[SAS and SATA device numbers](#)" on page 15).
- Hard drives must be SFF types.
- Drives should be the same capacity to provide the greatest storage space efficiency when drives are grouped together into the same drive array.

Removing hard drive blanks

CAUTION: To prevent improper cooling and thermal damage, do not operate the server unless all bays are populated with either a component or a blank.

Remove the component as indicated.

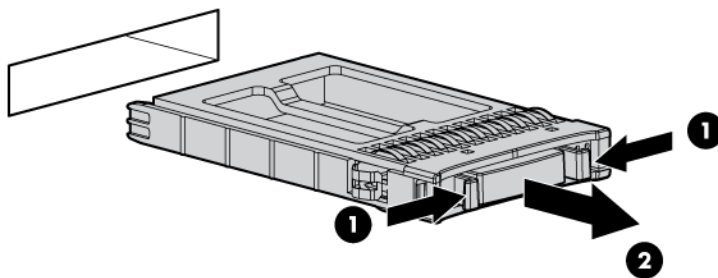

Removing hard drive bezel blanks

CAUTION: To prevent improper cooling and thermal damage, do not operate the server unless all bays are populated with either a component or a blank.

1. Remove hard drives 1 and 2 ("[Removing a hot-plug SAS hard drive](#)" on page 48).

2. Remove the hard drive bezel blank.

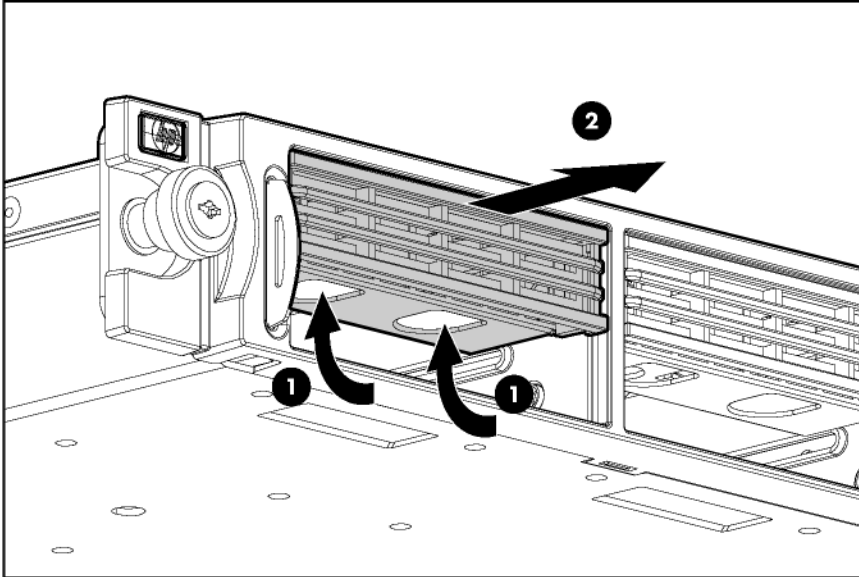

Removing the dual hard drive bezel blank

- ⚠ **CAUTION:** To prevent improper cooling and thermal damage, do not operate the server unless all bays are populated with either a component or a blank.

Remove the component as indicated.

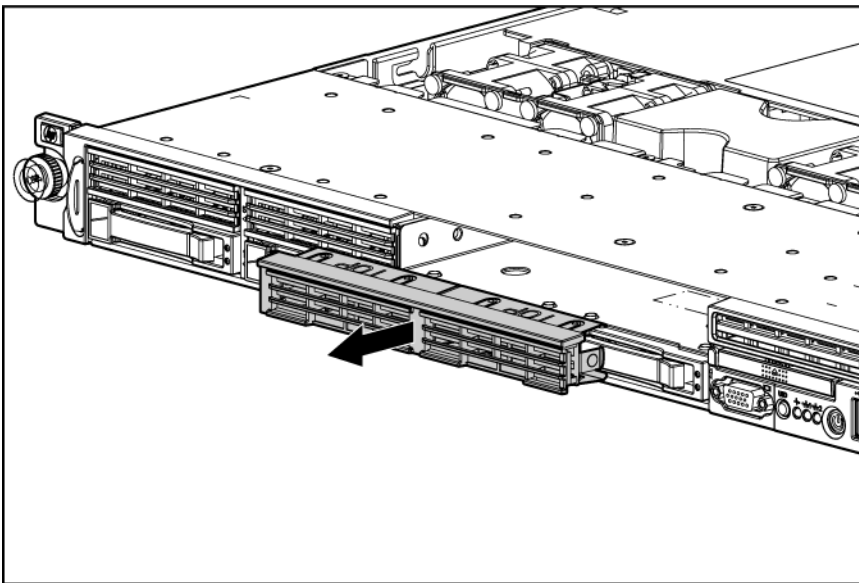

Removing a hot-plug SAS hard drive

- ⚠ **CAUTION:** For proper cooling do not operate the server without the access panel, baffles, expansion slot covers, or blanks installed. If the server supports hot-plug components, minimize the amount of time the access panel is open.

1. Determine the status of the hard drive from the hot-plug SAS hard drive LED combinations.

2. Back up all server data on the hard drive.
3. Remove the hard drive.

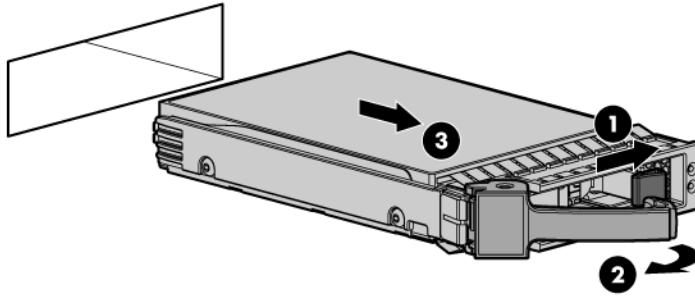

Installing a SAS hard drive

1. Remove the hard drive blank ("Removing hard drive blanks" on page 47).
2. Prepare the hard drive.

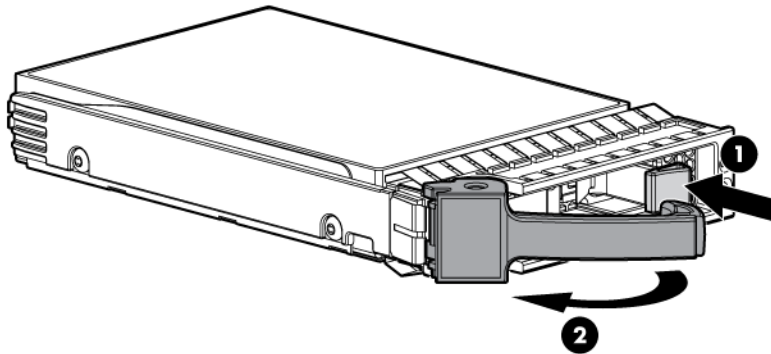

3. Install the hard drive.

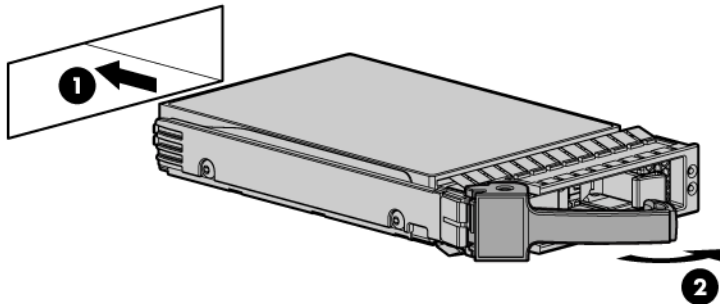

4. Determine the status of the hard drive from the hot-plug SAS hard drive LED combinations.

DVD-ROM and DVD-RW drive option

This server supports the installation of a DVD-ROM drive or a DVD-RW drive. When an optical drive is installed, the server does not support the additional hard drive backplane.

To install the component:

1. Power down the server (on page 19).
2. Extend the server from the rack (on page 19).
3. Remove the access panel (on page 21).
4. Remove the dual hard drive bezel blank ("[Removing the dual hard drive bezel blank](#)" on page 48).
5. Install the DVD-ROM drive in the DVD tray.

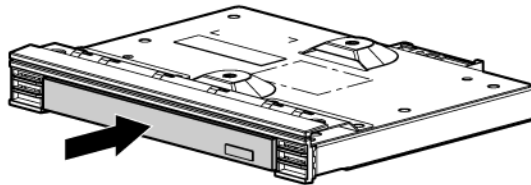

6. Secure the drive to the tray using the screw from this kit and the T-10/T-15 Torx screwdriver provided with the server.

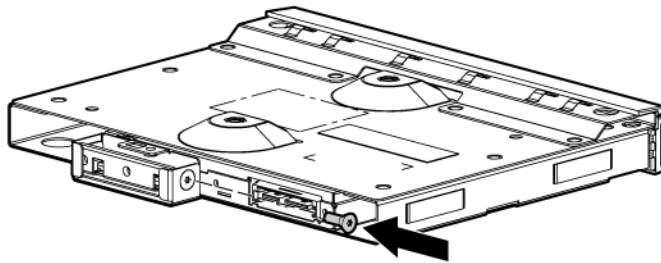

7. Install the DVD tray using the screws from this kit and the T-10/T-15 Torx screwdriver provided with the server.

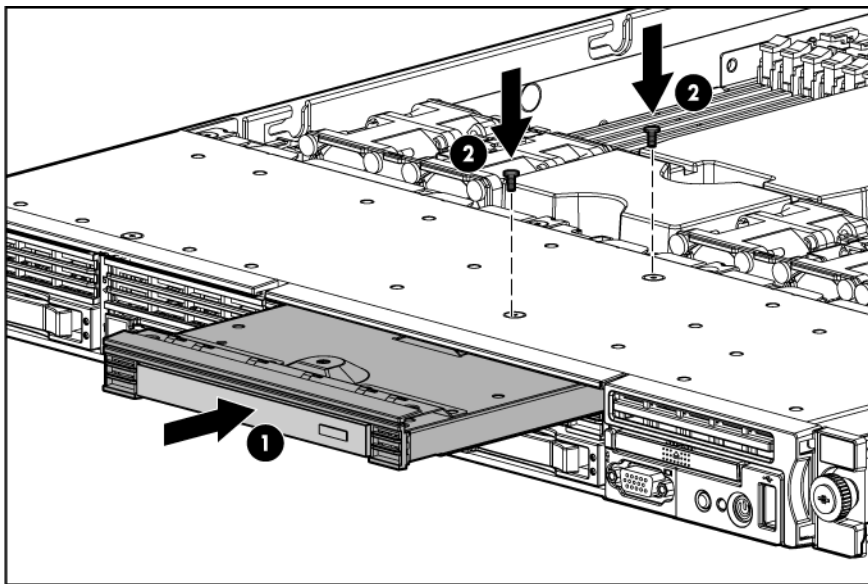

8. If installed, remove the BBWC battery pack or the FBWC capacitor pack (on page 21).
9. Remove the air baffle (on page 22).
10. Remove fan modules 3 and 4.

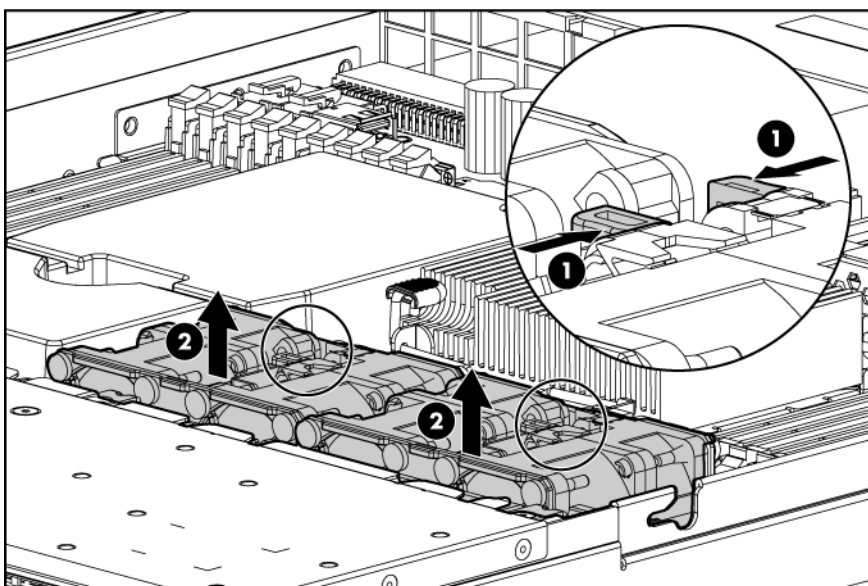

11. Connect the cable to the rear of the drive and to the SATA DVD-ROM drive connector on the system board.

12. Route the cable along the edge of the system board.

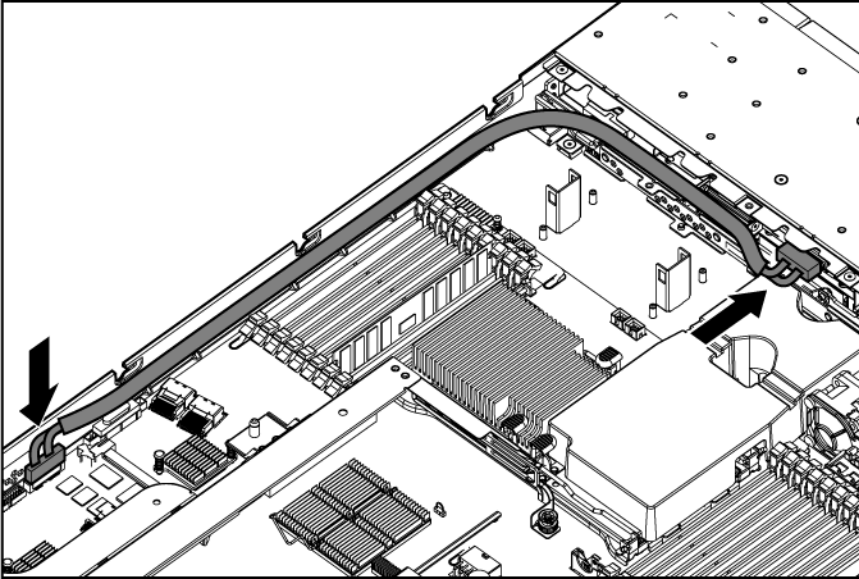

13. Install fan modules 3 and 4.

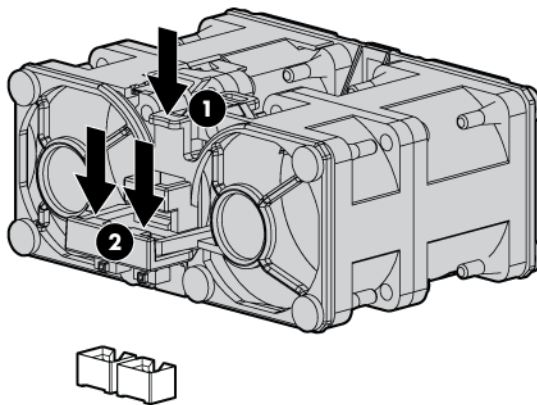

14. Install the air baffle (on page 22).
15. If removed, install the BBWC battery pack or the FBWC capacitor pack ("[Installing the BBWC battery pack or the FBWC capacitor pack](#)" on page 58).
16. Install the access panel (on page 21).
17. Slide the server into the rack.
18. Power up the server (on page 19).

Hard drive blackplane option

When the hard drive backplane option is installed, the server does not support the DVD-ROM or DVD-RW drive options.

To install the component:

1. Power down the server (on page 19).
2. Extend the server from the rack (on page 19).

3. Remove the access panel (on page 21).
4. Remove the hard drives from bays 1 and 2.
5. Remove the hard drive bezel blanks from hard drive bays 5 and 6 ("Removing hard drive bezel blanks" on page 47).
6. Remove the dual hard drive bezel blank ("Removing the dual hard drive bezel blank" on page 48).
7. Install the hard drive cage.

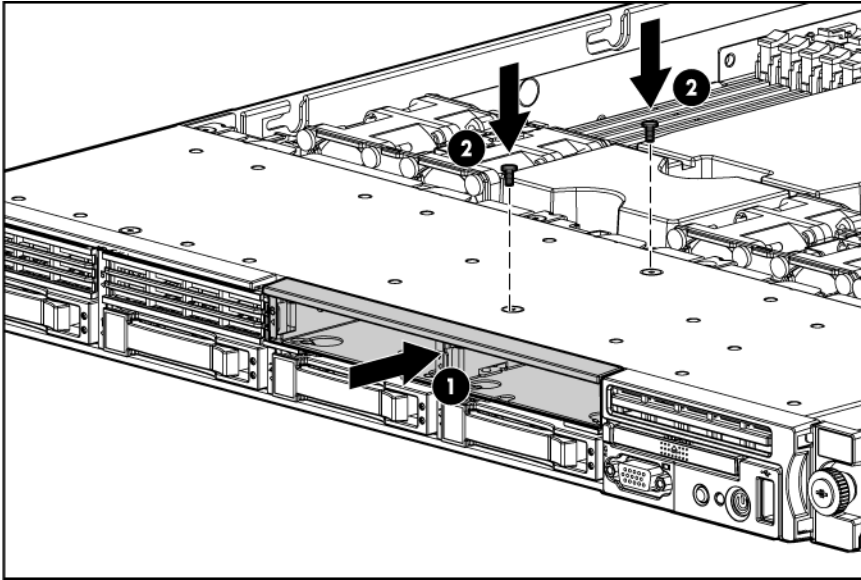

8. If installed, remove the BBWC battery pack or the FBWC capacitor pack (on page 21).
9. Remove the air baffle (on page 22).
10. Remove the fan blank.

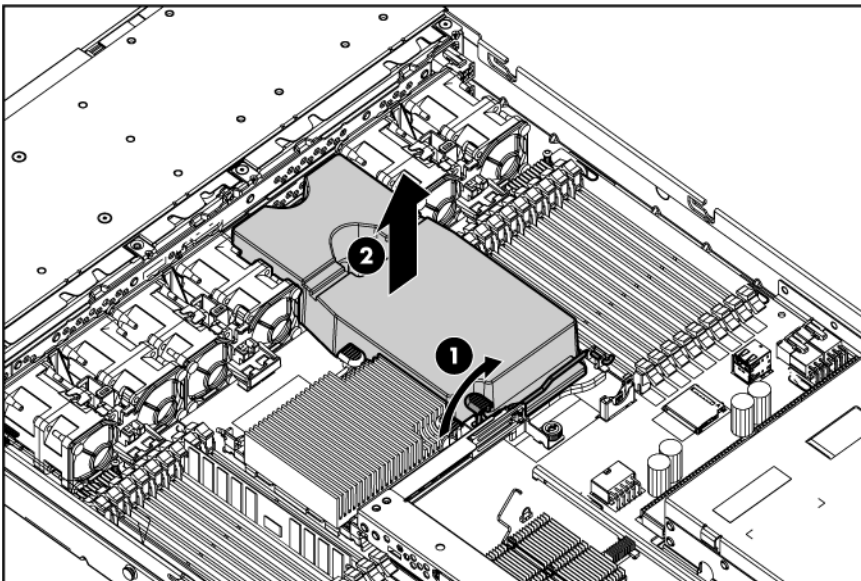

11. Remove all fan modules.

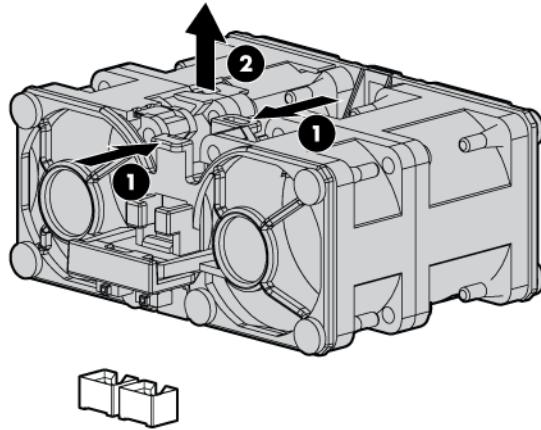

12. Connect the hard drive power cable and the hard drive data cable to the connectors on the hard drive backplane assembly.

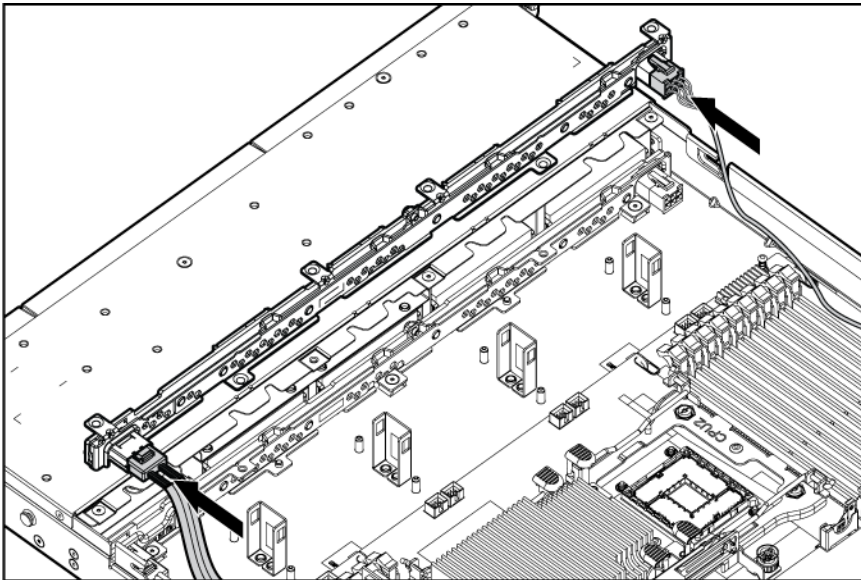

13. Align and install the optional hard drive backplane assembly.

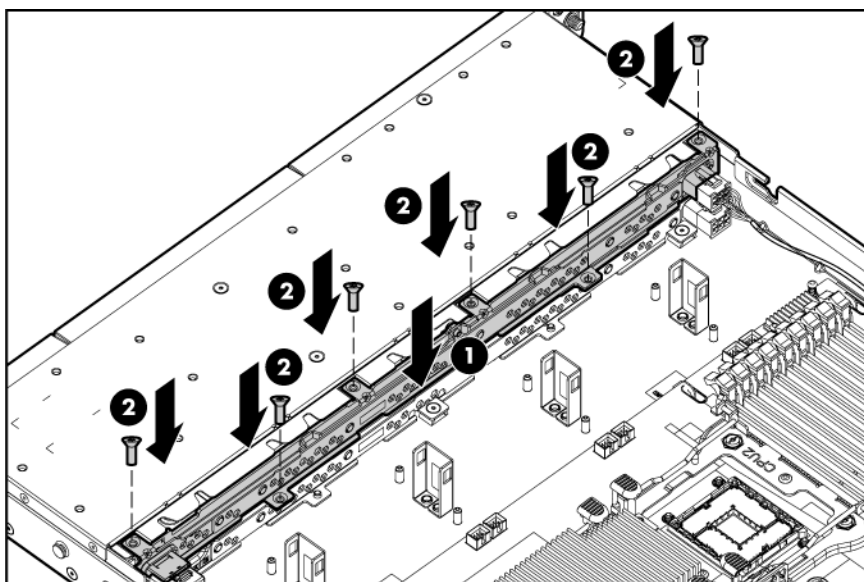

14. Connect the hard drive power cable and the hard drive data cable to the connectors on the system board.

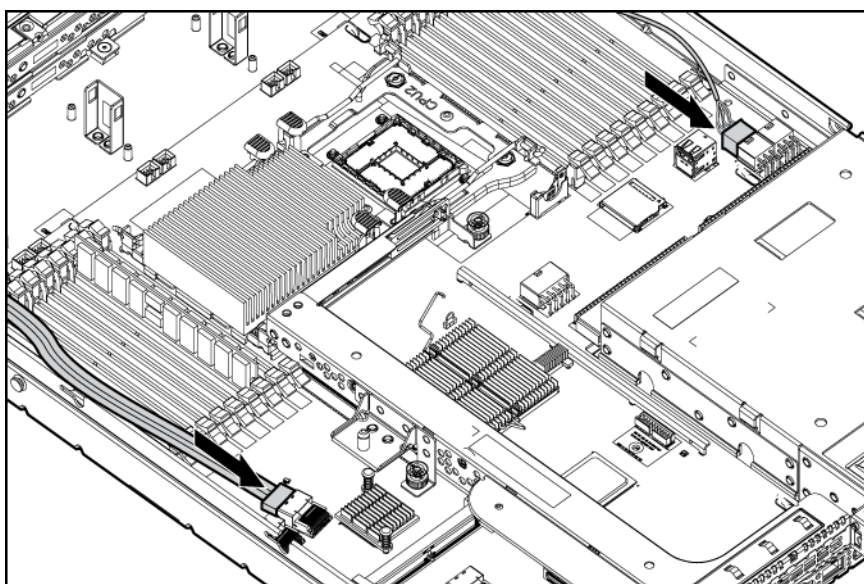

15. Install fan modules 3 and 4.

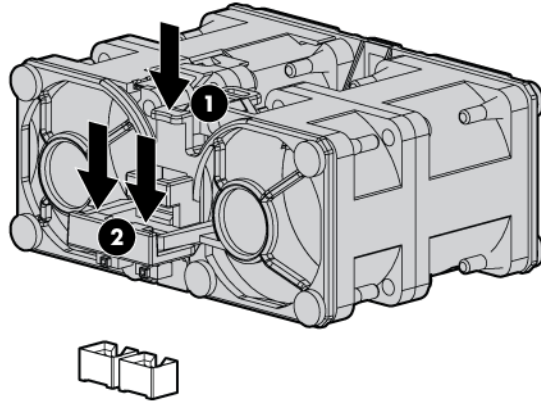

16. Install the fan blank.

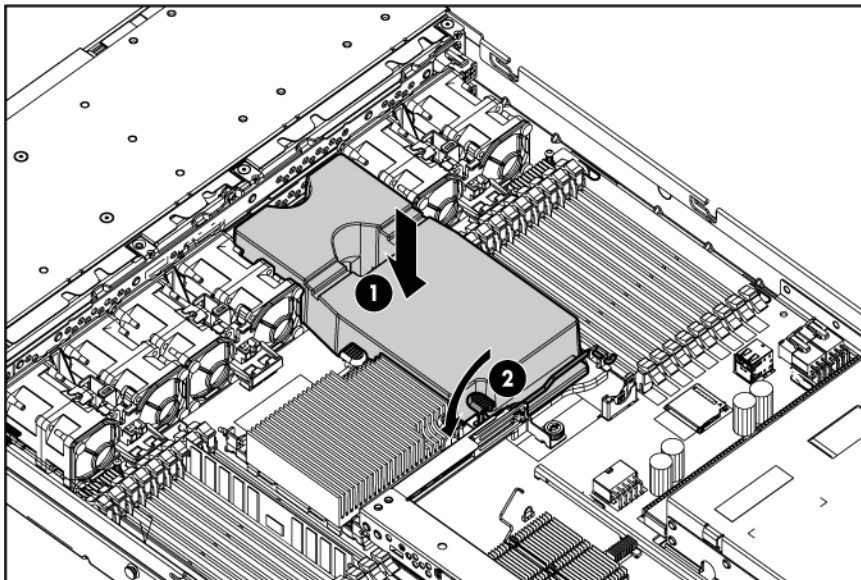

17. Install the air baffle (on page 22).
18. If removed, install the BBWC battery pack or the FBWC capacitor pack ("Installing the BBWC battery pack or the FBWC capacitor pack" on page 58).
19. Install hard drives or hard drive blanks into each bay.
20. Install the access panel (on page 21).
21. Slide the server into the rack.
22. Power up the server (on page 19).
23. Determine the status of the hard drive from the SAS and SATA hard drive LED combinations.

Controller options

The server ships with an embedded Smart Array P410i Controller. Upgrade options exist for the integrated array controller. For a list of supported options, see the QuickSpecs on the HP website (<http://www.hp.com/support>).

The server supports either of the following:

- Battery-backed write cache (BBWC) options

BBWC consists of a cache module and a battery pack (also called a BBWC enabler). The DDR cache module buffers and stores data being written by the controller. When the system power is on, the battery pack continuously recharges through a trickle-charging process lasting 15 minutes to 2 hours, depending on the original charge. In the event of system power failure, a fully charged battery pack can maintain the cached data for up to 72 hours.

- Flash-backed write cache (FBWC) options

FBWC consists of a cache module and a capacitor pack. The DDR cache module buffers and stores data being written by the controller. When the system power is on, the capacitor pack charges fully in about 5 minutes. In the event of a system power failure, a fully charged capacitor pack provides power for up to 80 seconds. During that interval, the controller transfers the cached data from DDR memory to flash memory, where the data remains indefinitely or until a controller retrieves the data.

 **CAUTION:** Do not use this controller with cache modules designed for other controller models, because the controller can malfunction and you can lose data. Also, do not transfer this cache module to a different controller module, because you can lose data.

 **CAUTION:** To prevent a server malfunction or damage to the equipment, do not add or remove the battery pack while an array capacity expansion, RAID level migration, or stripe size migration is in progress.

 **CAUTION:** After the server is powered down, wait 15 seconds and then check the amber LED before unplugging the cable from the cache module. If the amber LED blinks after 15 seconds, do not remove the cable from the cache module. The cache module is backing up data, and data is lost if the cable is detached.

 **IMPORTANT:** The battery pack might have a low charge when installed. In this case, a POST error message is displayed when the server is powered up, indicating that the battery pack is temporarily disabled. No action is necessary on your part. The internal circuitry automatically recharges the batteries and enables the battery pack. This process might take up to four hours. During this time, the cache module functions properly, but without the performance advantage of the battery pack.

NOTE: The data protection and the time limit also apply if a power outage occurs. When power is restored to the system, an initialization process writes the preserved data to the hard drives.

Installing the cache module

 **CAUTION:** In systems that use external data storage, be sure that the server is the first unit to be powered down and the last to be powered back up. Taking this precaution ensures that the system does not erroneously mark the drives as failed when the server is powered up.

1. Power down the server (on page 19).
2. Extend the server from the rack (on page 19).
3. Remove the access panel (on page 21).

4. Remove the PCI riser board assembly (on page 23).
5. Install the cache module in the SAS cache module connector on the system board. For connector locations, see "System board components (on page 11)."

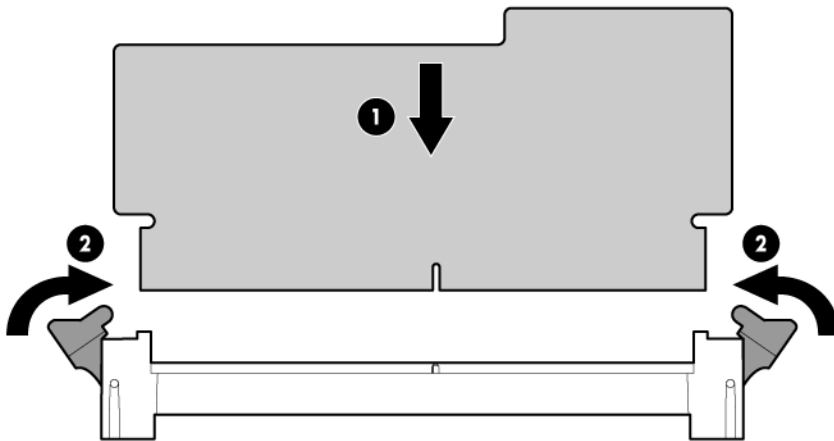

6. Install the PCI riser board assembly (on page 24).
7. Install the access panel (on page 21).
8. Slide the server into the rack.
9. Power up the server (on page 19).

Installing the BBWC battery pack or the FBWC capacitor pack

1. Power down the server (on page 19).
2. Extend the server from the rack (on page 19).
3. Remove the access panel (on page 21).
4. Remove the PCI riser board assembly (on page 23).
5. Install the cache module ("Installing the cache module" on page 57).

CAUTION: When connecting or disconnecting the capacitor pack cable, the connectors on the cache module and cable are susceptible to damage. Avoid excessive force and use caution to avoid damage to these connectors.

6. Install the BBWC battery pack or the FBWC capacitor pack.

7. Connect the BBWC cable or the FBWC cable to the cache module.

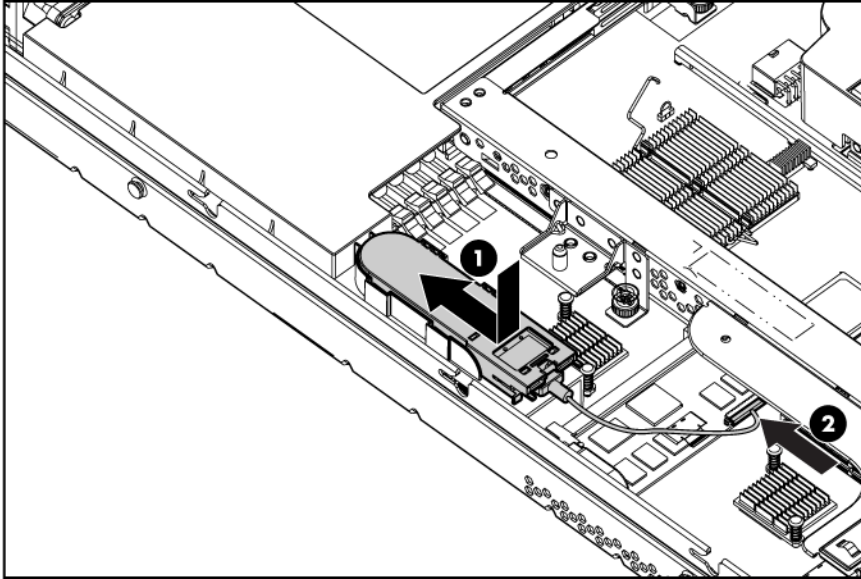

8. Install the PCI riser board assembly (on page 24).
9. Install the access panel (on page 21).
10. Slide the server into the rack.
11. Power up the server (on page 19).

Expansion board options

Installing an expansion board

The server ships with PCIe riser boards and expansion slots. PCI-X expansion boards are supported with optional riser boards.

1. Power down the server (on page 19).
2. Extend the server from the rack (on page 19).
3. Remove the access panel (on page 21).
4. Remove the PCI riser board assembly (on page 23).
5. Remove the expansion slot cover from the PCI riser board assembly.



IMPORTANT: If the expansion board ships with an extender bracket, remove it from the expansion board before inserting the board into the expansion slot of the PCI riser board assembly.

6. Install the expansion board into the slot until it seats firmly. The same procedures apply for installing an expansion board in PCI expansion slot 1.

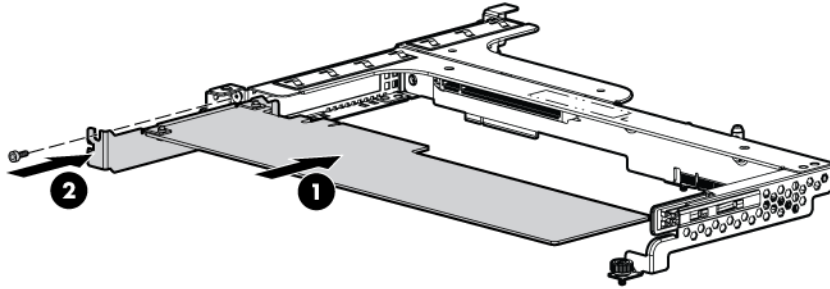

7. Install the PCI riser board assembly (on page 24).



IMPORTANT: The server does not power up if the PCI riser board assembly is not seated properly.

8. Connect all internal or external cabling to the expansion boards.
9. Install the access panel (on page 21).
10. Slide the server into the rack.
11. Power up the server (on page 19).

Installing a PCI-X riser board



IMPORTANT: The PCI-X riser board installed in this document supports PCI-X expansion boards only.

1. Power down the server (on page 19).
2. Extend the server from the rack (on page 19).
3. Remove the access panel (on page 21).
4. Remove the PCI riser board assembly (on page 23).
5. Remove all expansion boards, if installed.

6. Remove the full-length PCIe riser board from the riser board assembly.

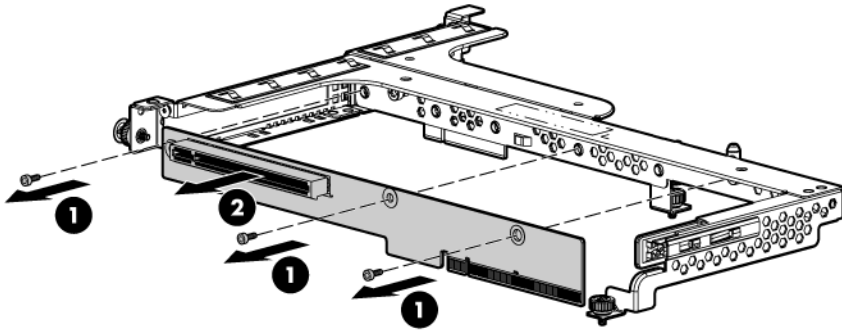

7. Install the PCI-X riser board on the riser board assembly.

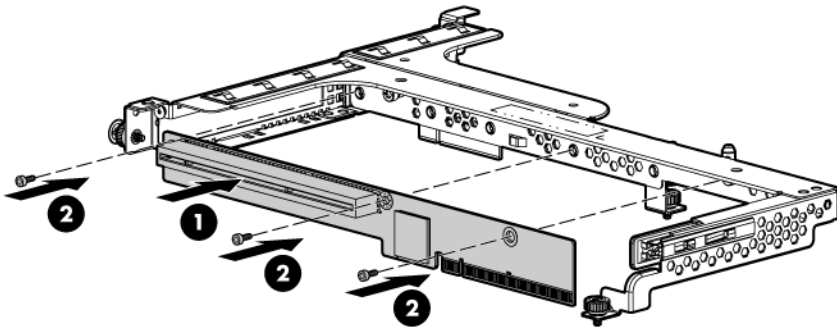

IMPORTANT: If the expansion board ships with an extender bracket, remove it from the expansion board before inserting the board into the expansion slot of the PCI riser board assembly.

8. If necessary, install the expansion boards ("Installing an expansion board" on page 59).
9. Install the PCI riser board assembly (on page 24).



IMPORTANT: The server does not power up if the PCI riser board assembly is not seated properly.

10. Connect all internal cabling to the expansion boards.
11. Install the access panel (on page 21).
12. Slide the server into the rack.
13. Power up the server (on page 19).

PCI thermal - power option

The PCI thermal - power option kit provides a PCI power cable and a fan that are required when installing a high-power graphics adapter (150W) on the server.

Before installing a high-power graphics adapter (150W) in the server, be sure that the power supplies support the installation of the adapter. Due the high power requirements for the adapter, a 750W power

supply may be required. For more information, see the HP Enterprise Configurator website (<http://h30099.www3.hp.com/configurator/>).

To install the component:

1. Power down the server (on page 19).
2. Extend the server from the rack (on page 19).
3. Remove the access panel (on page 21).
4. If installed, remove the BBWC battery pack or the FBWC capacitor pack (on page 21).
5. Remove the air baffle (on page 22).
6. Remove the fan blank.

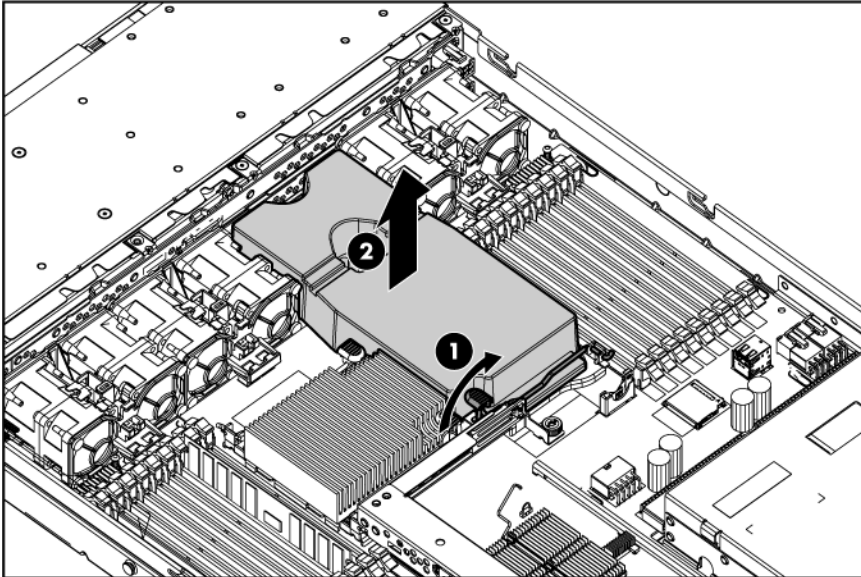

7. Install the fan module.

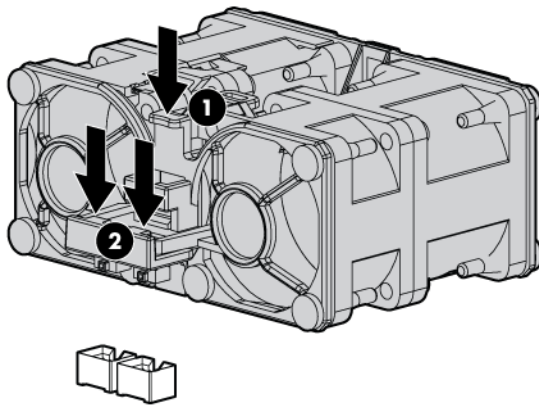

8. Remove the PCI riser board assembly (on page 23).
9. Remove expansion slot cover 2 from the PCI riser board assembly.

10. Install the graphics adapter in slot 2 on the PCI riser board assembly.

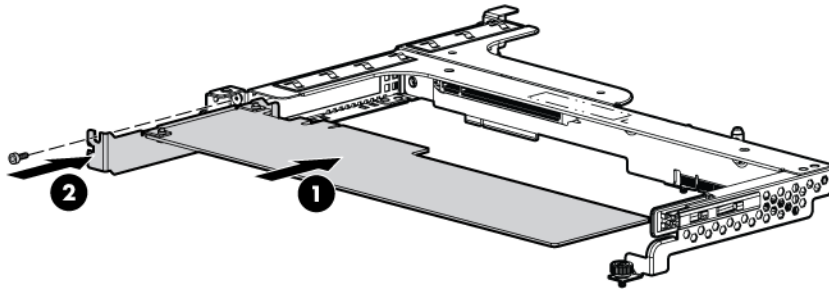

11. Install the PCI riser board assembly (on page 24).
12. Connect the PCI power cable to the connector on the 150W graphics adapter and the system board.

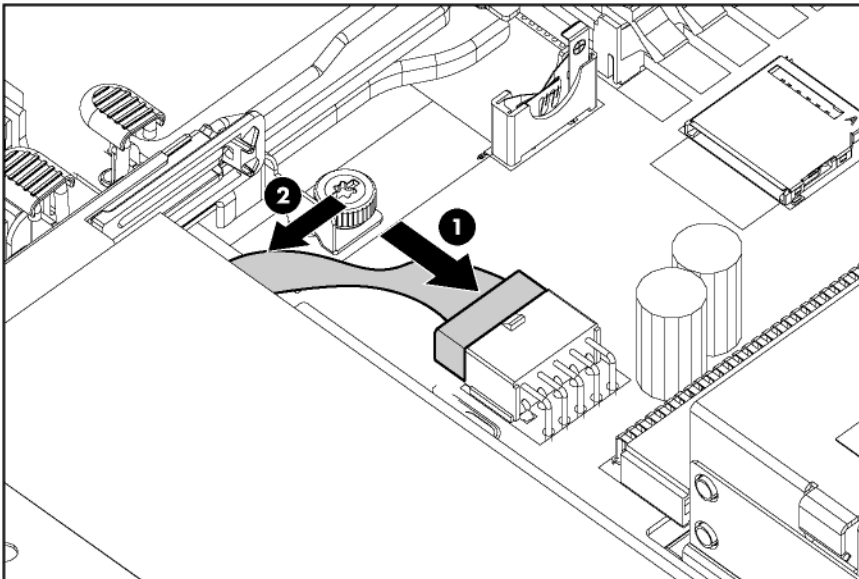

13. Install the air baffle (on page 22).
14. If removed, install the BBWC battery pack or the FBWC capacitor pack ("[Installing the BBWC battery pack or the FBWC capacitor pack](#)" on page 58).
15. Install the access panel (on page 21).
16. Slide the server into the rack.
17. Power up the server (on page 19).

Redundant hot-plug power supply option

-
- ⚠ **CAUTION:** All power supplies installed in the server must have the same output power capacity. Verify that all power supplies have the same part number and label color. The system becomes unstable and may shut down when it detects mismatched power supplies.
-

Label color	Output
Blue	460W
Orange	750W
Green	1,200W
White	1,200W -48Vdc

-
- ⚠ **CAUTION:** To prevent improper cooling and thermal damage, do not operate the server unless all bays are populated with either a component or a blank.
-

To install the component:

1. Unfasten the cable management solution to access the power supply bays.
2. Remove the power supply blank.

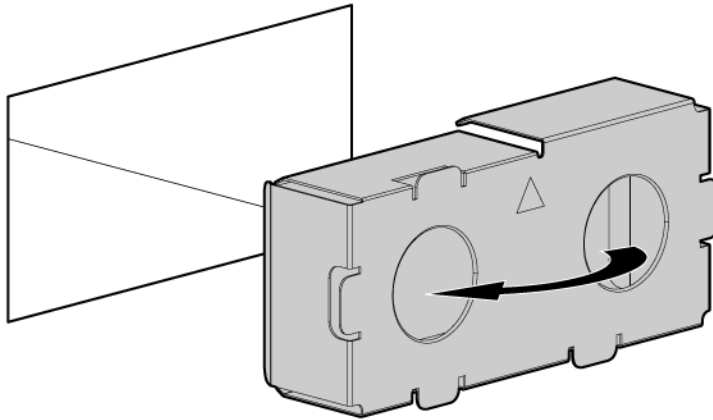

3. Remove the protective cover from the connector pins on the power supply.

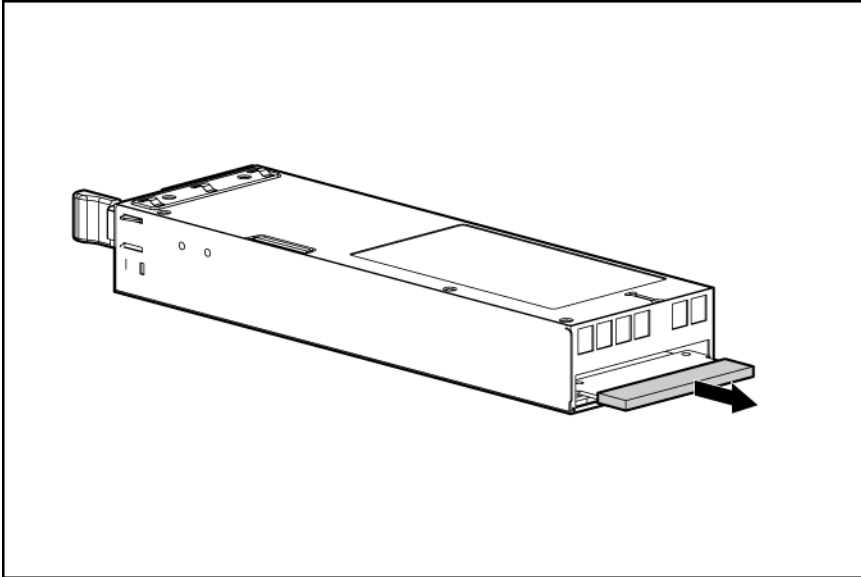

WARNING: To reduce the risk of electric shock or damage to the equipment, do not connect the power cord to the power supply until the power supply is installed.

4. Install the redundant power supply into the bay until it clicks.

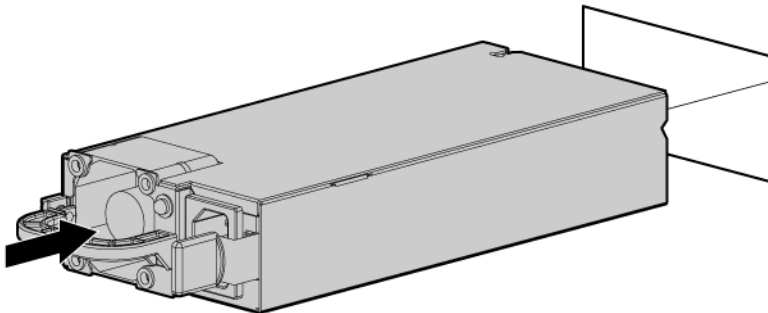

5. Connect the power cord to the power supply.

6. Use the strain relief clip from the server hardware kit to secure the power cord.

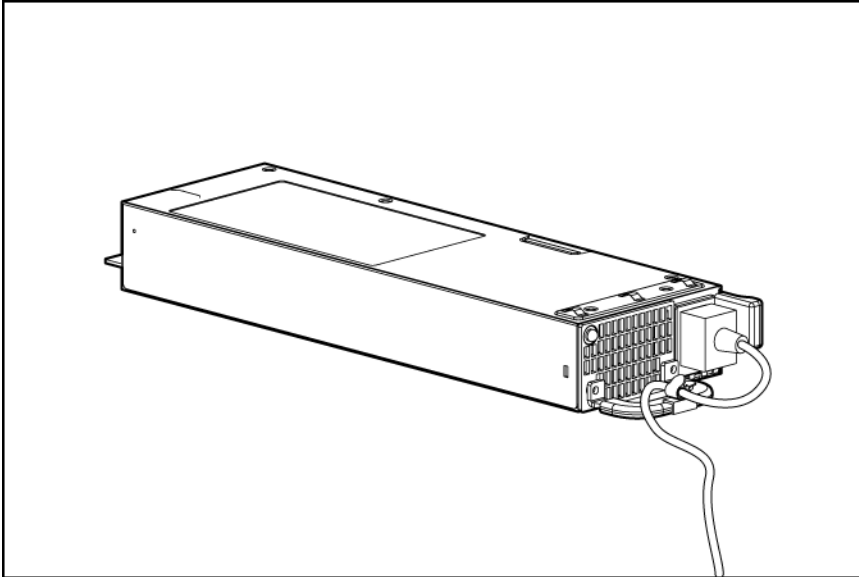

7. Route the power cord through the cable management solution.
8. Connect the power cord to the power source.
9. Be sure that the power supply LED is green ("[Rear panel LEDs and buttons](#)" on page 10).

HP Trusted Platform Module option

Use these instructions to install and enable a TPM on a supported server. This procedure includes three sections:

1. Installing the Trusted Platform Module board (on page 67).
2. Retaining the recovery key/password (on page 68).
3. Enabling the Trusted Platform Module (on page 68).

Enabling the TPM requires accessing the ROM-Based Setup Utility (RBSU) ("[HP ROM-Based Setup Utility](#)" on page 74). For more information about RBSU, see the HP website (<http://www.hp.com/support/smartstart/documentation>).

TPM installation requires the use of drive encryption technology, such as the Microsoft® Windows® BitLocker™ Drive Encryption feature. For more information on BitLocker™, see the Microsoft website (<http://www.microsoft.com>).



CAUTION: Always observe the guidelines in this document. Failure to follow these guidelines can cause hardware damage or halt data access.

When installing or replacing a TPM, observe the following guidelines:

- Do not remove an installed TPM. Once installed, the TPM becomes a permanent part of the system board.
- When installing or replacing hardware, HP service providers cannot enable the TPM or the encryption technology. For security reasons, only the customer can enable these features.
- When returning a system board for service replacement, do not remove the TPM from the system board. When requested, HP Service provides a TPM with the spare system board.

- Any attempt to remove an installed TPM from the system board breaks or disfigures the TPM security rivet. Upon locating a broken or disfigured rivet on an installed TPM, administrators should consider the system compromised and take appropriate measures to ensure the integrity of the system data.
- When using BitLocker™, always retain the recovery key/password. The recovery key/password is required to enter Recovery Mode after BitLocker™ detects a possible compromise of system integrity.
- HP is not liable for blocked data access caused by improper TPM use. For operating instructions, see the encryption technology feature documentation provided by the operating system.

Installing the Trusted Platform Module board

⚠ WARNING: To reduce the risk of personal injury, electric shock, or damage to the equipment, remove the power cord to remove power from the server. The front panel Power On/Standby button does not completely shut off system power. Portions of the power supply and some internal circuitry remain active until AC power is removed.

⚠ WARNING: To reduce the risk of personal injury from hot surfaces, allow the drives and the internal system components to cool before touching them.

1. Power down the server (on page 19).
2. Extend the server from the rack (on page 19).
3. Remove the access panel (on page 21).
4. Remove the PCI riser board assembly (on page 23).

⚠ CAUTION: Any attempt to remove an installed TPM from the system board breaks or disfigures the TPM security rivet. Upon locating a broken or disfigured rivet on an installed TPM, administrators should consider the system compromised and take appropriate measures to ensure the integrity of the system data.

5. Install the TPM board. Press down on the connector to seat the board ("[System board components](#)" on page 11).

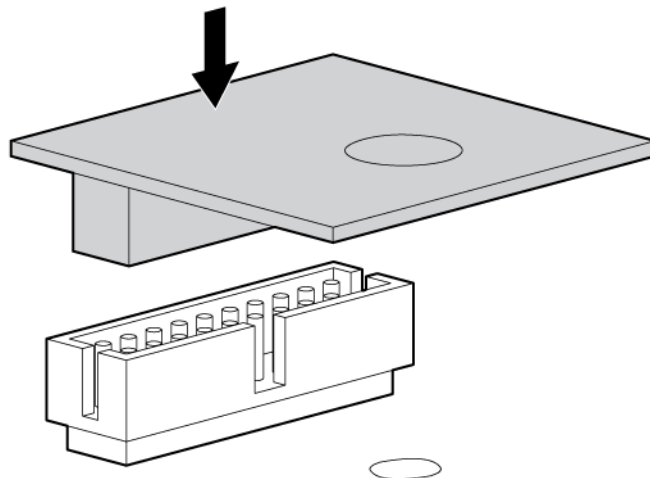

6. Install the TPM security rivet by pressing the rivet firmly into the system board.

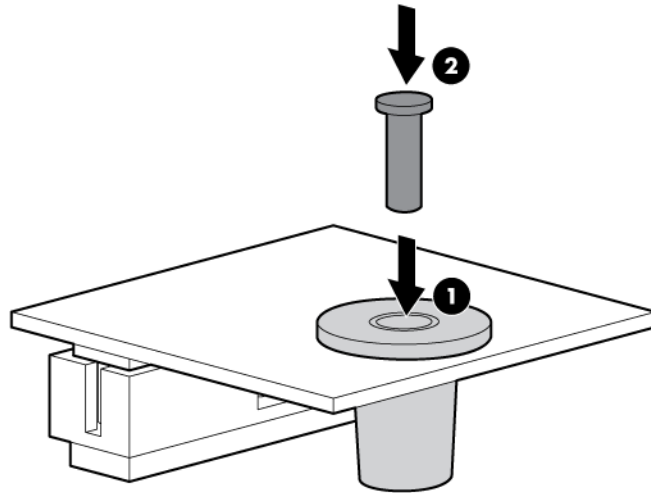

7. Install the PCI riser board assembly (on page 24).
8. Install the access panel (on page 21).
9. Slide the server into the rack.
10. Power up the server (on page 19).

Retaining the recovery key/password

The recovery key/password is generated during BitLocker™ setup, and can be saved and printed after BitLocker™ is enabled. When using BitLocker™, always retain the recovery key/password. The recovery key/password is required to enter Recovery Mode after BitLocker™ detects a possible compromise of system integrity.

To help ensure maximum security, observe the following guidelines when retaining the recovery key/password:

- Always store the recovery key/password in multiple locations.
- Always store copies of the recovery key/password away from the server.
- Do not save the recovery key/password on the encrypted hard drive.

Enabling the Trusted Platform Module

1. When prompted during the start-up sequence, access RBSU by pressing the **F9** key.
2. From the Main Menu, select **Server Security**.
3. From the Server Security Menu, select **Trusted Platform Module**.
4. From the Trusted Platform Module Menu, select **TPM Functionality**.
5. Select **Enable**, and then press the **Enter** key to modify the TPM Functionality setting.
6. Press the **Esc** key to exit the current menu, or press the **F10** key to exit RBSU.
7. Reboot the server.
8. Enable the TPM in the OS. For OS-specific instructions, see the OS documentation.



CAUTION: When a TPM is installed and enabled on the server, data access is locked if you fail to follow the proper procedures for updating the system or option firmware, replacing the system board, replacing a hard drive, or modifying OS application TPM settings.

For more information on firmware updates and hardware procedures, see the *HP Trusted Platform Module Best Practices White Paper* on the HP website (<http://www.hp.com/support>).

For more information on adjusting TPM usage in BitLocker™, see the Microsoft website (<http://technet.microsoft.com/en-us/library/cc732774.aspx>).

Cabling

Cabling overview

This section provides guidelines that help you make informed decisions about cabling the server and hardware options to optimize performance.

For information on cabling peripheral components, refer to the white paper on high-density deployment at the HP website (<http://www.hp.com/products/servers/platforms>).

- △ **CAUTION:** When routing cables, always be sure that the cables are not in a position where they can be pinched or crimped.

Hard drive backplane cabling

The server ships with one hard drive backplane that supports four hard drives. Installation of the optional, second hard drive backplane enables the server to support eight hard drives.

- Hard drive backplane

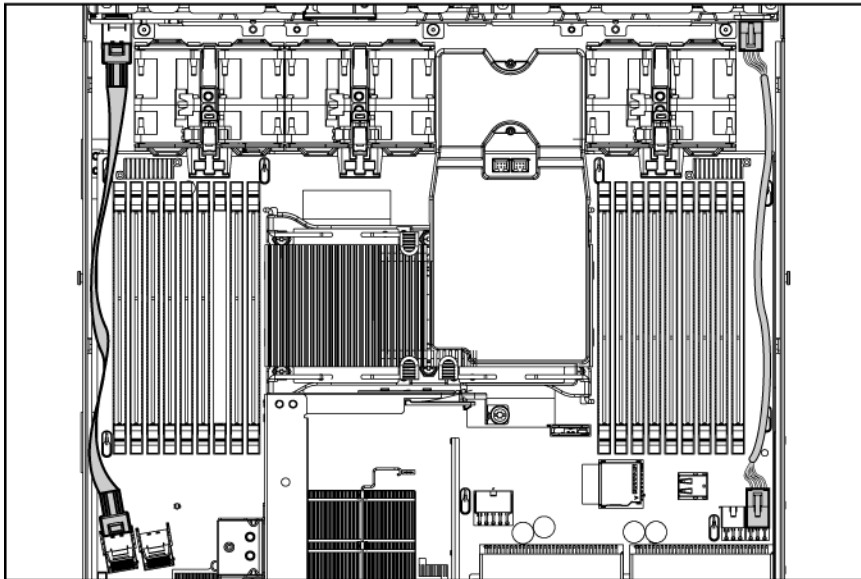

- Optional hard drive backplane

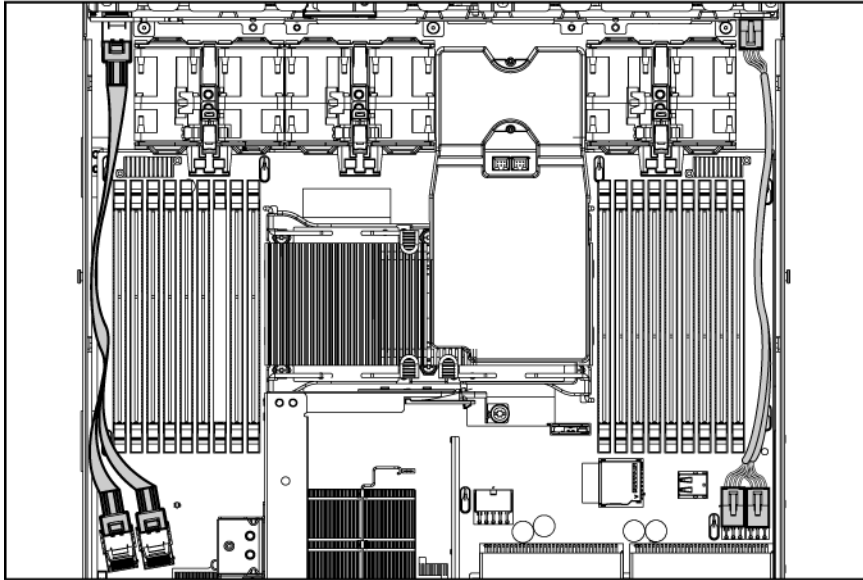

BBWC battery pack or FBWC capacitor pack cabling

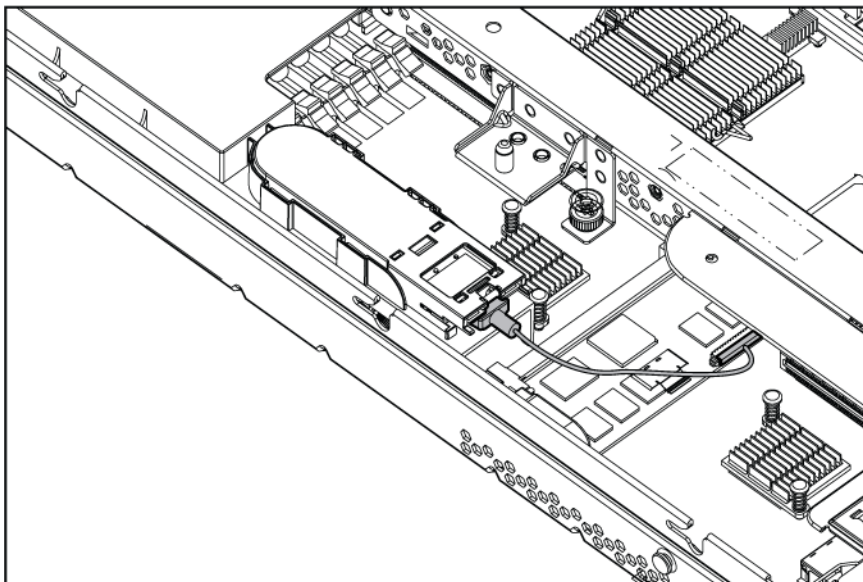

DVD-ROM and DVD-RW drive cabling

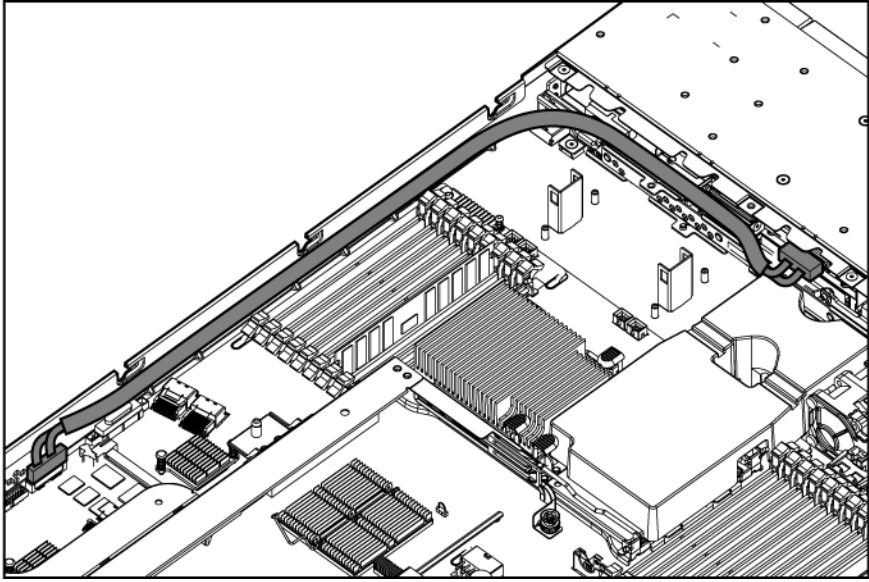

Power button and Systems Insight Display cabling

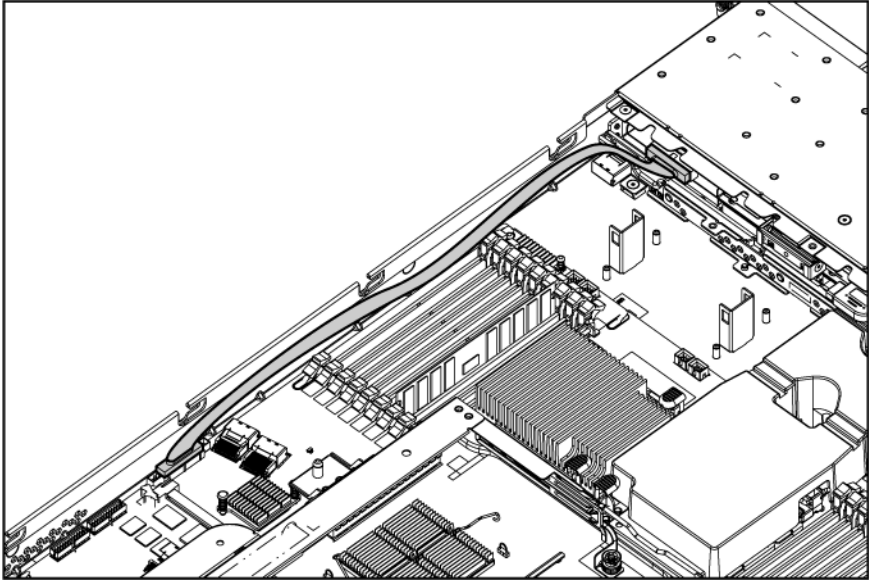

PCI power cabling

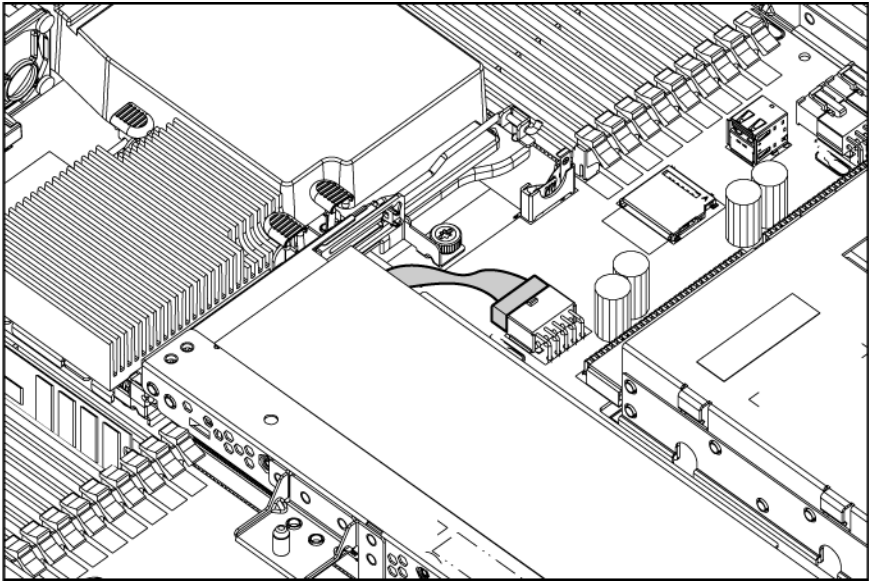

Software and configuration utilities

Configuration tools

SmartStart software

SmartStart is a collection of software that optimizes single-server setup, providing a simple and consistent way to deploy server configuration. SmartStart has been tested on many ProLiant server products, resulting in proven, reliable configurations.

SmartStart assists the deployment process by performing a wide range of configuration activities, including:

- Preparing the system for installing "off-the-shelf" versions of leading operating system software
- Installing optimized server drivers, management agents, and utilities automatically with every assisted installation
- Testing server hardware using the Insight Diagnostics Utility ("[HP Insight Diagnostics](#)" on page 81)
- Installing software drivers directly from the CD. With systems that have Internet connection, the SmartStart Autorun Menu provides access to a complete list of ProLiant system software.
- Enabling access to the Array Configuration Utility (on page 78) and Erase Utility (on page 80)

SmartStart is included in the HP Insight Foundation suite for ProLiant. For more information about SmartStart software, see the HP Insight Foundation suite for ProLiant or the HP website (<http://www.hp.com/go/foundation>).

SmartStart Scripting Toolkit

The SmartStart Scripting Toolkit is a server deployment product that allows you to build an unattended automated installation for high-volume server deployments. The SmartStart Scripting Toolkit is designed to support ProLiant BL, ML, DL, and SL servers. The toolkit includes a modular set of utilities and important documentation that describes how to apply these tools to build an automated server deployment process.

The Scripting Toolkit provides a flexible way to create standard server configuration scripts. These scripts are used to automate many of the manual steps in the server configuration process. This automated server configuration process cuts time from each deployment, making it possible to scale rapid, high-volume server deployments.

For more information, and to download the SmartStart Scripting Toolkit, see the HP website (<http://www.hp.com/servers/sstoolkit>).

HP ROM-Based Setup Utility

RBSU is a configuration utility embedded in ProLiant servers that performs a wide range of configuration activities that can include the following:

- Configuring system devices and installed options

- Enabling and disabling system features
- Displaying system information
- Selecting the primary boot controller
- Configuring memory options
- Language selection

For more information on RBSU, see the *HP ROM-Based Setup Utility User Guide* on the Documentation CD or the HP website (<http://www.hp.com/support/smartstart/documentation>).

Using RBSU

To use RBSU, use the following keys:

- To access RBSU, press the **F9** key during power-up when prompted.
- To navigate the menu system, use the arrow keys.
- To make selections, press the **Enter** key.
- To access Help for a highlighted configuration option, press the **F1** key.



IMPORTANT: RBSU automatically saves settings when you press the **Enter** key. The utility does not prompt you for confirmation of settings before you exit the utility. To change a selected setting, you must select a different setting and press the **Enter** key.

Default configuration settings are applied to the server at one of the following times:

- Upon the first system power-up
- After defaults have been restored

Default configuration settings are sufficient for proper typical server operation, but configuration settings can be modified using RBSU. The system will prompt you for access to RBSU with each power-up.

Auto-configuration process

The auto-configuration process automatically runs when you boot the server for the first time. During the power-up sequence, the system ROM automatically configures the entire system without needing any intervention. During this process, the ORCA utility, in most cases, automatically configures the array to a default setting based on the number of drives connected to the server.

NOTE: The server may not support all the following examples.

NOTE: If the boot drive is not empty or has been written to in the past, ORCA does not automatically configure the array. You must run ORCA to configure the array settings.

Drives installed	Drives used	RAID level
1	1	RAID 0
2	2	RAID 1
3, 4, 5, or 6	3, 4, 5, or 6	RAID 5
More than 6	0	None

To change any ORCA default settings and override the auto-configuration process, press the **F8** key when prompted.

For more information on RBSU, see the *HP ROM-Based Setup Utility User Guide* on the Documentation CD or the HP website (<http://www.hp.com/support/smartstart/documentation>).

Boot options

Near the end of the boot process, the boot options screen is displayed. This screen is visible for several seconds before the system attempts to boot from a supported boot device. During this time, you can do the following:

- Access RBSU by pressing the **F9** key.
- Access the System Maintenance Menu (which enables you to launch ROM-based Diagnostics or Inspect) by pressing the **F10** key.
- Access the boot menu by pressing the **F11** key.
- Force a PXE Network boot by pressing the **F12** key.

BIOS Serial Console

BIOS Serial Console allows you to configure the serial port to view POST error messages and run RBSU remotely through a serial connection to the server COM port. The server that you are remotely configuring does not require a keyboard and mouse.

For more information about BIOS Serial Console, see the *BIOS Serial Console User Guide* on the Documentation CD or the HP website (<http://www.hp.com/support/smartstart/documentation>).

Configuring AMP modes

Not all ProLiant servers support all AMP modes. RBSU provides menu options only for the modes supported by the server. Advanced memory protection within RBSU enables the following advanced memory.

- **Advanced ECC Mode**—Provides memory protection beyond Standard ECC. All single-bit failures and some multi-bit failures can be corrected without resulting in system downtime.
- **Online Spare Mode**—Provides protection against failing or degraded DIMMs. Certain memory is set aside as spare, and automatic failover to spare memory occurs when the system detects a degraded DIMM. DIMMs that are likely to receive a fatal/uncorrectable memory error are removed from operation automatically, resulting in less system downtime.

See the server-specific user guide for DIMM population requirements.

- **Mirrored Memory Mode**—Provides protection against uncorrectable memory errors that would otherwise result in system failure. In this mode, the system maintains two copies of all data. If an uncorrectable memory error occurs, the system automatically retrieves the good data from the mirrored copy. The system continues to operate normally without any user intervention. If the system supports hot-plug memory, the failed memory can be replaced while the system continues to operate.
- **RAID Memory Mode**—Provides protection levels similar to Mirrored Memory Mode, and it requires less memory allocation than full redundancy.

Configuring Advanced ECC memory

To configure Advanced ECC memory:

1. Install the required DIMMs ("Installing a DIMM" on page 46).
2. When the prompt appears, access RBSU by pressing the **F9** key during power-up.
3. Select **System Options**.
4. Select **Advanced Memory Protection**.
5. Select **Advanced ECC Memory**.
6. Press the **Enter** key.
7. Press the **Esc** key to exit the current menu or press the **F10** key to exit RBSU.

For more information on Advanced ECC, see the HP website (<http://h18000.www1.hp.com/products/servers/technology/memoryprotection.html>).

Configuring lockstep memory

To configure Lockstep memory:

1. Install the required DIMMs ("Installing a DIMM" on page 46).
2. Access RBSU by pressing the **F9** key during power-up when the prompt is displayed.
3. Select **System Options**.
4. Select **Advanced Memory Protection**.
5. Select **Lockstep with Advanced ECC Support**.
6. Press the **Enter** key.
7. Press the **Esc** key to exit the current menu, or press the **F10** key to exit RBSU.

For more information on Lockstep memory, see the white paper on the HP website (<http://h18000.www1.hp.com/products/servers/technology/memoryprotection.html>).

Configuring online spare memory

To configure online spare memory:

1. Install the required DIMMs ("Installing a DIMM" on page 46).
2. When the prompt appears, access RBSU by pressing the **F9** key during power-up.
3. Select **System Options**.
4. Select **Advanced Memory Protection**.
5. Select **Online Spare with Advanced ECC Support**.
6. Press the **Enter** key.
7. Press the **Esc** key to exit the current menu, or press the **F10** key to exit RBSU.

For more information on online spare memory, see the HP website (<http://h18000.www1.hp.com/products/servers/technology/memoryprotection.html>).

Configuring mirrored memory

To configure mirrored memory:

1. Install the required DIMMs ("Installing a DIMM" on page 46).

2. Access RBSU by pressing the **F9** key during power-up when the prompt is displayed.
3. Select **System Options**.
4. Select **Advanced Memory Protection**.
5. Select **Mirrored Memory with Advanced ECC Support**.
6. Press the **Enter** key.
7. Press the **Esc** key to exit the current menu or press the **F10** key to exit RBSU.

For more information on mirrored memory, see the white paper on the HP website (<http://h18000.www1.hp.com/products/servers/technology/memoryprotection.html>).

Array Configuration Utility

ACU is a browser-based utility with the following features:

- Runs as a local application or remote service
- Supports online array capacity expansion, logical drive extension, assignment of online spares, and RAID or stripe size migration
- Suggests the optimum configuration for an unconfigured system
- Provides different operating modes, enabling faster configuration or greater control over the configuration options
- Remains available any time that the server is on
- Displays on-screen tips for individual steps of a configuration procedure
- Beginning with ACU version 8.28.13.0, provides diagnostic functionality on the Diagnostics tab (formerly known as Array Diagnostics Utility).

For optimum performance, the minimum display settings are 1024 × 768 resolution and 16-bit color. Servers running Microsoft® operating systems require one of the following supported browsers:

- Internet Explorer 6.0 or later
- Mozilla Firefox 2.0 or later

For Linux servers, see the README.TXT file for additional browser and support information.

For more information, see the *Configuring Arrays on HP Smart Array Controllers Reference Guide* on the Documentation CD or the HP website (<http://www.hp.com>).

Option ROM Configuration for Arrays

Before installing an operating system, you can use the ORCA utility to create the first logical drive, assign RAID levels, and establish online spare configurations.

The utility also provides support for the following functions:

- Reconfiguring one or more logical drives
- Viewing the current logical drive configuration
- Deleting a logical drive configuration
- Setting the controller to be the boot controller

If you do not use the utility, ORCA will default to the standard configuration.

For more information regarding array controller configuration, refer to the controller user guide.

For more information regarding the default configurations that ORCA uses, refer to the *HP ROM-Based Setup Utility User Guide* on the Documentation CD.

Re-entering the server serial number and product ID

After you replace the system board, you must re-enter the server serial number and the product ID.

1. During the server startup sequence, press the **F9** key to access RBSU.
2. Select the **Advanced Options** menu.
3. Select **Service Options**.
4. Select **Serial Number**. The following warnings appear:
WARNING! WARNING! WARNING! The serial number is loaded into the system during the manufacturing process and should NOT be modified. This option should only be used by qualified service personnel. This value should always match the serial number sticker located on the chassis.
Warning: The serial number should ONLY be modified by qualified personnel. This value should always match the serial number located on the chassis.
5. Press the **Enter** key to clear the warning.
6. Enter the serial number and press the **Enter** key.
7. Select **Product ID**. The following warning appears:
Warning: The Product ID should ONLY be modified by qualified personnel. This value should always match the Product ID on the chassis.
8. Enter the product ID and press the **Enter** key.
9. Press the **Esc** key to close the menu.
10. Press the **Esc** key to exit RBSU.
11. Press the **F10** key to confirm exiting RBSU. The server automatically reboots.

Management tools

Automatic Server Recovery

ASR is a feature that causes the system to restart when a catastrophic operating system error occurs, such as a blue screen, ABEND, or panic. A system fail-safe timer, the ASR timer, starts when the System Management driver, also known as the Health Driver, is loaded. When the operating system is functioning properly, the system periodically resets the timer. However, when the operating system fails, the timer expires and restarts the server.

ASR increases server availability by restarting the server within a specified time after a system hang or shutdown. At the same time, the HP SIM console notifies you by sending a message to a designated pager number that ASR has restarted the system. You can disable ASR from the HP SIM console or through RBSU.

ROMPaa utility

The ROMPaa utility enables you to upgrade the system firmware (BIOS). To upgrade the firmware, insert a ROMPaa USB Key into an available USB port and boot the system. In addition to ROMPaa, Online Flash Components for Windows and Linux operating systems are available for updating the system firmware.

The ROMPaa utility checks the system and provides a choice (if more than one exists) of available firmware revisions.

For more information, see the Download drivers and software page for the server. To access the server-specific page, enter the following web address into the browser:

<http://www.hp.com/support/<servername>>

For example:

<http://www.hp.com/support/dl360g6>

Integrated Lights-Out 3 technology

The iLO 3 subsystem is a standard component of selected ProLiant servers that provides server health and remote server manageability. The iLO 3 subsystem includes an intelligent microprocessor, secure memory, and a dedicated network interface. This design makes iLO 3 independent of the host server and its operating system.

In addition to remote management features, iLO 3 is also responsible for managing the health of the ProLiant server. The intelligence of iLO 3 manages the Sea of Sensors thermal control, directs the Dynamic Power Capping technology, and monitors the health of server components.

The iLO 3 subsystem provides secure remote access from any authorized network client. The enhancements to iLO 3 enable customers to get work done faster by providing turbo-charged remote access performance, a streamlined user experience, and enhanced standards support.

Using iLO 3, you can do the following:

- Access a high-performance and secure Remote Console to the server from anywhere in the world.
- Use the shared iLO 3 Remote Console to collaborate with up to six server administrators.
- Remotely mount high-performance Virtual Media devices to the server.
- Securely and remotely control the power state of the managed server.
- Send alerts from iLO 3 regardless of the state of the host server.
- Access advanced troubleshooting features through the iLO 3 interface.

For more information about iLO 3 features (which may require an iLO Advanced Pack or iLO Advanced for BladeSystem license), see the iLO 3 documentation on the Documentation CD or on the HP website (<http://www.hp.com/go/ilo>).

Erase Utility



CAUTION: Perform a backup before running the System Erase Utility. The utility sets the system to its original factory state, deletes the current hardware configuration information, including array setup and disk partitioning, and erases all connected hard drives completely. Refer to the instructions for using this utility.

Run the Erase Utility if you must erase the system for the following reasons:

- You want to install a new operating system on a server with an existing operating system.
- You encounter an error when completing the steps of a factory-installed operating system installation.

To access the Erase Utility, use the System Erase button on the home screen of the SmartStart CD ("[SmartStart software](#)" on page 74).

Redundant ROM support

The server enables you to upgrade or configure the ROM safely with redundant ROM support. The server has a single ROM that acts as two separate ROM images. In the standard implementation, one side of the ROM contains the current ROM program version, while the other side of the ROM contains a backup version.

NOTE: The server ships with the same version programmed on each side of the ROM.

Safety and security benefits

When you flash the system ROM, ROMPaq writes over the backup ROM and saves the current ROM as a backup, enabling you to switch easily to the alternate ROM version if the new ROM becomes corrupted for any reason. This feature protects the existing ROM version, even if you experience a power failure while flashing the ROM.

USB support

HP provides both standard USB 2.0 support and legacy USB 2.0 support. Standard support is provided by the OS through the appropriate USB device drivers. Before the OS loads, HP provides support for USB devices through legacy USB support, which is enabled by default in the system ROM.

Legacy USB support provides USB functionality in environments where USB support is not available normally. Specifically, HP provides legacy USB functionality for the following:

- POST
- RBSU
- Diagnostics
- DOS
- Operating environments which do not provide native USB support

Diagnostic tools

HP Insight Diagnostics

HP Insight Diagnostics is a proactive server management tool, available in both offline and online versions, that provides diagnostics and troubleshooting capabilities to assist IT administrators who verify server installations, troubleshoot problems, and perform repair validation.

HP Insight Diagnostics Offline Edition performs various in-depth system and component testing while the OS is not running. To run this utility, launch the SmartStart CD.

HP Insight Diagnostics Online Edition is a web-based application that captures system configuration and other related data needed for effective server management. Available in Microsoft® Windows® and Linux versions, the utility helps to ensure proper system operation.

For more information or to download the utility, refer to the HP website (<http://www.hp.com/servers/diags>).

HP Insight Diagnostics survey functionality

HP Insight Diagnostics (on page 81) provides survey functionality that gathers critical hardware and software information on ProLiant servers.

This functionality supports operating systems that may not be supported by the server. For operating systems supported by the server, see the HP website (<http://www.hp.com/go/supportos>).

If a significant change occurs between data-gathering intervals, the survey function marks the previous information and overwrites the survey data files to reflect the latest changes in the configuration.

Survey functionality is installed with every SmartStart-assisted HP Insight Diagnostics installation, or it can be installed through the HP PSP ("ProLiant Support Packs" on page 84).

NOTE: The current version of SmartStart provides the memory spare part numbers for the server. To download the latest version, see the HP website (<http://www.hp.com/support>).

Integrated Management Log

The IML records hundreds of events and stores them in an easy-to-view form. The IML timestamps each event with 1-minute granularity.

You can view recorded events in the IML in several ways, including the following:

- From within HP SIM
- From within Survey Utility
- From within operating system-specific IML viewers
 - For NetWare: IML Viewer
 - For Windows®: IML Viewer
 - For Linux: IML Viewer Application
- From within the iLO 3 user interface
- From within HP Insight Diagnostics (on page 81)

For more information, see the Management CD in the HP Insight Foundation suite for ProLiant.

Remote support and analysis tools

HP Insight Remote Support software

HP strongly recommends that you install HP Insight Remote Support software to complete the installation or upgrade of your product and to enable enhanced delivery of your HP Warranty, HP Care Pack Service, or HP contractual support agreement. HP Insight Remote Support supplements your monitoring 24 x 7 to ensure maximum system availability by providing intelligent event diagnosis, and automatic, secure submission of hardware event notifications to HP, which will initiate a fast and accurate resolution, based on your product's service level. Notifications may be sent to your authorized HP Channel Partner for on-site service, if configured and available in your country. The software is available in two variants:

- HP Insight Remote Support Standard: This software supports server and storage devices and is optimized for environments with 1–50 servers. Ideal for customers who can benefit from proactive notification but do not need proactive service delivery and integration with a management platform.
- HP Insight Remote Support Advanced: This software provides comprehensive remote monitoring and proactive service support for nearly all HP servers, storage, network, and SAN environments, plus selected non-HP servers that have a support obligation with HP. It is integrated with HP Systems Insight Manager. A dedicated server is recommended to host both HP Systems Insight Manager and HP Insight Remote Support Advanced.

Details for both versions are available on the HP website (<http://www.hp.com/go/insightremotesupport>).

To download the software, go to Software Depot (<http://www.software.hp.com>).

Select **Insight Remote Support** from the menu on the right.

Keeping the system current

Drivers



IMPORTANT: Always perform a backup before installing or updating device drivers.

The server includes new hardware that may not have driver support on all OS installation media.

If you are installing a SmartStart-supported OS, use the SmartStart software (on page 74) and its Assisted Path feature to install the OS and latest driver support.

If you are installing drivers from the SmartStart CD, be sure that you are using the latest SmartStart version that your server supports. To verify that your server is using the latest supported version, see the HP website (<http://www.hp.com/support>). For more information, see the documentation provided with the SmartStart CD.

If you do not use the SmartStart CD to install an OS, drivers for some of the new hardware are required. These drivers, as well as other option drivers, ROM images, and value-add software can be downloaded from the HP website (<http://www.hp.com/support>).

To directly locate the OS drivers for a particular server, enter the following web address into the browser:

`http://www.hp.com/support/<servername>`

In place of `<servername>`, enter the server name.

For example:

<http://www.hp.com/support/dl360g6> (<http://www.hp.com/support/dl360g6>)

Version control

The VCRM and VCA are Web-enabled Insight Management Agents tools that HP SIM uses to facilitate and schedule software update tasks to the entire enterprise.

- VCRM manages the repository for Windows and Linux PSPs as well as online firmware. Administrators can browse a graphical view of the PSPs or configure VCRM to automatically update the repository with Internet downloads of the latest software from HP.
- VCA compares installed software versions and available updates. Administrators can configure VCA to point to a repository managed by VCRM.

For more information about version control tools, see the *HP Systems Insight Manager Help Guide* and the *Version Control User Guide* on the HP Systems Insight Manager website (<http://www.hp.com/go/hpsim>).

ProLiant Support Packs

PSPs represent operating system-specific bundles of ProLiant optimized drivers, utilities, and management agents. Refer to the PSP website (<http://h18000.www1.hp.com/products/servers/management/psp.html>).

Operating System Version Support

For information about specific versions of a supported operating system, refer to the operating system support matrix (<http://www.hp.com/go/supportos>).

Firmware

The Smart Update Firmware DVD is an organized firmware collection for ProLiant servers and options powered by HP Smart Update Manager (on page 84). The Smart Update Firmware DVD combines the following resources on a single DVD:

- Firmware Maintenance CD
- HP BladeSystem Firmware Deployment Tool (FDT)
- The HP BladeSystem online firmware bundles
- The ProLiant BladeSystem Release Sets
- Offline, automatic mode for HP ProLiant BL, DL, ML, and 100 Series servers
- Firmware deployment support for HP ProLiant 100 Series servers

HP Smart Update Manager

The HP Smart Update Manager provides intelligent and flexible firmware and software deployment. This technology assists in reducing the complexity of provisioning and updating HP ProLiant Servers, options, and Blades within the datacenter. HP SUM is delivered on The Smart Update Firmware DVD, ProLiant Support Packs, and Easy Set-up CDs.

HP SUM enables system administrators to upgrade ROM images efficiently across a wide range of servers and options. This tool has the following features:

- Enables GUI and a command-line, scriptable interface
- Enables scriptable, command-line deployment
- Requires no agent for remote installations
- Enables dependency checking, which ensures appropriate install order and dependency checking between components
- Deploys software and firmware on Windows and Linux operating systems
- Performs local or remote (one-to-many) online deployment
- Deploys firmware and software together
- Supports offline and online deployment
- Deploys necessary component updates only (except Linux RPMs)
- Downloads the latest components from Web (except Linux RPMs)
- Enables direct update of BMC firmware (iLO and LO100i)

For more information about HP Smart Update Manager and to access the *HP Smart Update Manager User Guide*, see the HP website (<http://www.hp.com/go/foundation>).

Change control and proactive notification

HP offers Change Control and Proactive Notification to notify customers 30 to 60 days in advance of upcoming hardware and software changes on HP commercial products.

For more information, refer to the HP website (<http://www.hp.com/go/pcn>).

Care Pack

HP Care Pack Services offer upgraded service levels to extend and expand bundled services with easy-to-buy, easy-to-use support packages that help you make the most of your server investments. For more information, see the HP website (<http://www.hp.com/services/carepack>).

Troubleshooting

Troubleshooting resources

The *HP ProLiant Servers Troubleshooting Guide* provides procedures for resolving common problems and comprehensive courses of action for fault isolation and identification, error message interpretation, issue resolution, and software maintenance on ProLiant servers and server blades. This guide includes problem-specific flowcharts to help you navigate complex troubleshooting processes. To view the guide, select a language:

- English (http://www.hp.com/support/ProLiant_TSG_en)
- French (http://www.hp.com/support/ProLiant_TSG_fr)
- Italian (http://www.hp.com/support/ProLiant_TSG_it)
- Spanish (http://www.hp.com/support/ProLiant_TSG_sp)
- German (http://www.hp.com/support/ProLiant_TSG_gr)
- Dutch (http://www.hp.com/support/ProLiant_TSG_nl)
- Japanese (http://www.hp.com/support/ProLiant_TSG_jp)

Pre-diagnostic steps



WARNING: To avoid potential problems, ALWAYS read the warnings and cautionary information in the server documentation before removing, replacing, reseating, or modifying system components.



IMPORTANT: This guide provides information for multiple servers. Some information may not apply to the server you are troubleshooting. Refer to the server documentation for information on procedures, hardware options, software tools, and operating systems supported by the server.

1. Review the important safety information (on page 86).
2. Gather symptom information (on page 88).
3. Prepare the server for diagnosis (on page 89).
4. Use the Start diagnosis flowchart (on page 90) to begin the diagnostic process.

Important safety information

Familiarize yourself with the safety information in the following sections before troubleshooting the server.



Important safety information

Before servicing this product, read the *Important Safety Information* document provided with the server.

Symbols on equipment

The following symbols may be placed on equipment to indicate the presence of potentially hazardous conditions.

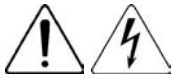

This symbol indicates the presence of hazardous energy circuits or electric shock hazards. Refer all servicing to qualified personnel.

WARNING: To reduce the risk of injury from electric shock hazards, do not open this enclosure. Refer all maintenance, upgrades, and servicing to qualified personnel.



This symbol indicates the presence of electric shock hazards. The area contains no user or field serviceable parts. Do not open for any reason.

WARNING: To reduce the risk of injury from electric shock hazards, do not open this enclosure.



This symbol on an RJ-45 receptacle indicates a network interface connection.

WARNING: To reduce the risk of electric shock, fire, or damage to the equipment, do not plug telephone or telecommunications connectors into this receptacle.



This symbol indicates the presence of a hot surface or hot component. If this surface is contacted, the potential for injury exists.

WARNING: To reduce the risk of injury from a hot component, allow the surface to cool before touching.



14.06 - 15.97
kg

31.00 - 35.20
lb

This symbol indicates that the component exceeds the recommended weight for one individual to handle safely.

WARNING: To reduce the risk of personal injury or damage to the equipment, observe local occupational health and safety requirements and guidelines for manual material handling.



These symbols, on power supplies or systems, indicate that the equipment is supplied by multiple sources of power.

WARNING: To reduce the risk of injury from electric shock, remove all power cords to completely disconnect power from the system.

Warnings and cautions



WARNING: Only authorized technicians trained by HP should attempt to repair this equipment. All troubleshooting and repair procedures are detailed to allow only subassembly/module-level repair. Because of the complexity of the individual boards and subassemblies, no one should attempt to make repairs at the component level or to make modifications to any printed wiring board. Improper repairs can create a safety hazard.



WARNING: To reduce the risk of personal injury or damage to the equipment, be sure that:

- The leveling feet are extended to the floor.
- The full weight of the rack rests on the leveling feet.
- The stabilizing feet are attached to the rack if it is a single-rack installation.
- The racks are coupled together in multiple-rack installations.
- Only one component is extended at a time. A rack may become unstable if more than one component is extended for any reason.



WARNING: To reduce the risk of electric shock or damage to the equipment:

- Do not disable the power cord grounding plug. The grounding plug is an important safety feature.
- Plug the power cord into a grounded (earthed) electrical outlet that is easily accessible at all times.
- Unplug the power cord from the power supply to disconnect power to the equipment.
- Do not route the power cord where it can be walked on or pinched by items placed against it. Pay particular attention to the plug, electrical outlet, and the point where the cord extends from the server.



14.06 - 15.97

kg

31.00 - 35.20

lb

WARNING: To reduce the risk of personal injury or damage to the equipment:

- Observe local occupation health and safety requirements and guidelines for manual handling.
- Obtain adequate assistance to lift and stabilize the chassis during installation or removal.
- The server is unstable when not fastened to the rails.
- When mounting the server in a rack, remove the power supplies and any other removable module to reduce the overall weight of the product.



CAUTION: To properly ventilate the system, you must provide at least 7.6 cm (3.0 in) of clearance at the front and back of the server.



CAUTION: The server is designed to be electrically grounded (earthed). To ensure proper operation, plug the AC power cord into a properly grounded AC outlet only.

Symptom information

Before troubleshooting a server problem, collect the following information:

- What events preceded the failure? After which steps does the problem occur?
- What has been changed since the time the server was working?
- Did you recently add or remove hardware or software? If so, did you remember to change the appropriate settings in the server setup utility, if necessary?
- How long has the server exhibited problem symptoms?
- If the problem occurs randomly, what is the duration or frequency?

To answer these questions, the following information may be useful:

- Run HP Insight Diagnostics (on page 81) and use the survey page to view the current configuration or to compare it to previous configurations.
- Refer to your hardware and software records for information.
- Refer to server LEDs and their statuses.

Prepare the server for diagnosis

1. Be sure the server is in the proper operating environment with adequate power, air conditioning, and humidity control. For required environmental conditions, see the server documentation.
2. Record any error messages displayed by the system.
3. Remove all diskettes, CD-ROMs, DVD-ROMs, and USB drive keys.
4. Power down the server and peripheral devices if you will be diagnosing the server offline. If possible, always perform an orderly shutdown:
 - a. Exit any applications.
 - b. Exit the operating system.
 - c. Power down the server (on page 19).
5. Disconnect any peripheral devices not required for testing (any devices not necessary to power up the server). Do not disconnect the printer if you want to use it to print error messages.
6. Collect all tools and utilities, such as a Torx screwdriver, loopback adapters, ESD wrist strap, and software utilities, necessary to troubleshoot the problem.
 - You must have the appropriate Health Drivers and Management Agents installed on the server. To verify the server configuration, connect to the System Management homepage and select **Version Control Agent**. The VCA gives you a list of names and versions of all installed HP drivers, Management Agents, and utilities, and whether they are up-to-date.
 - HP recommends you have access to the server documentation for server-specific information.
 - HP recommends you have access to the SmartStart CD for value-added software and drivers required during the troubleshooting process. Download the current version of SmartStart from the HP website (<http://www.hp.com/servers/smartstart>).

Loose connections

Action:

- Be sure all power cords are securely connected.
- Be sure all cables are properly aligned and securely connected for all external and internal components.
- Remove and check all data and power cables for damage. Be sure no cables have bent pins or damaged connectors.
- If a fixed cable tray is available for the server, be sure the cords and cables connected to the server are routed correctly through the tray.
- Be sure each device is properly seated. Avoid bending or flexing circuit boards when reseating components.
- If a device has latches, be sure they are completely closed and locked.

- Check any interlock or interconnect LEDs that may indicate a component is not connected properly.
- If problems continue to occur, remove and reinstall each device, checking the connectors and sockets for bent pins or other damage.

Service notifications

To view the latest service notifications, refer to the HP website (<http://www.hp.com/go/bizsupport>). Select the appropriate server model, and then click the **Troubleshoot a Problem** link on the product page.

Troubleshooting flowcharts

To effectively troubleshoot a problem, HP recommends that you start with the first flowchart in this section, "Start diagnosis flowchart (on page 90)," and follow the appropriate diagnostic path. If the other flowcharts do not provide a troubleshooting solution, follow the diagnostic steps in "General diagnosis flowchart (on page 91)." The General diagnosis flowchart is a generic troubleshooting process to be used when the problem is not server-specific or is not easily categorized into the other flowcharts.

The available flowcharts include:

- Start diagnosis flowchart (on page 90)
- General diagnosis flowchart (on page 91)
- Server power-on problems flowchart (on page 93)
- POST problems flowchart (on page 96)
- OS boot problems flowchart (on page 97)
- Server fault indications flowchart (on page 99)

Start diagnosis flowchart

Use the following flowchart to start the diagnostic process.

Item	Refer to
1	"General diagnosis flowchart (on page 91)"
2	"Power-on problems flowchart ("Server power-on problems flowchart" on page 93)"
3	"POST problems flowchart (on page 96)"
4	"OS boot problems flowchart (on page 97)"
5	"Server fault indications flowchart (on page 99)"

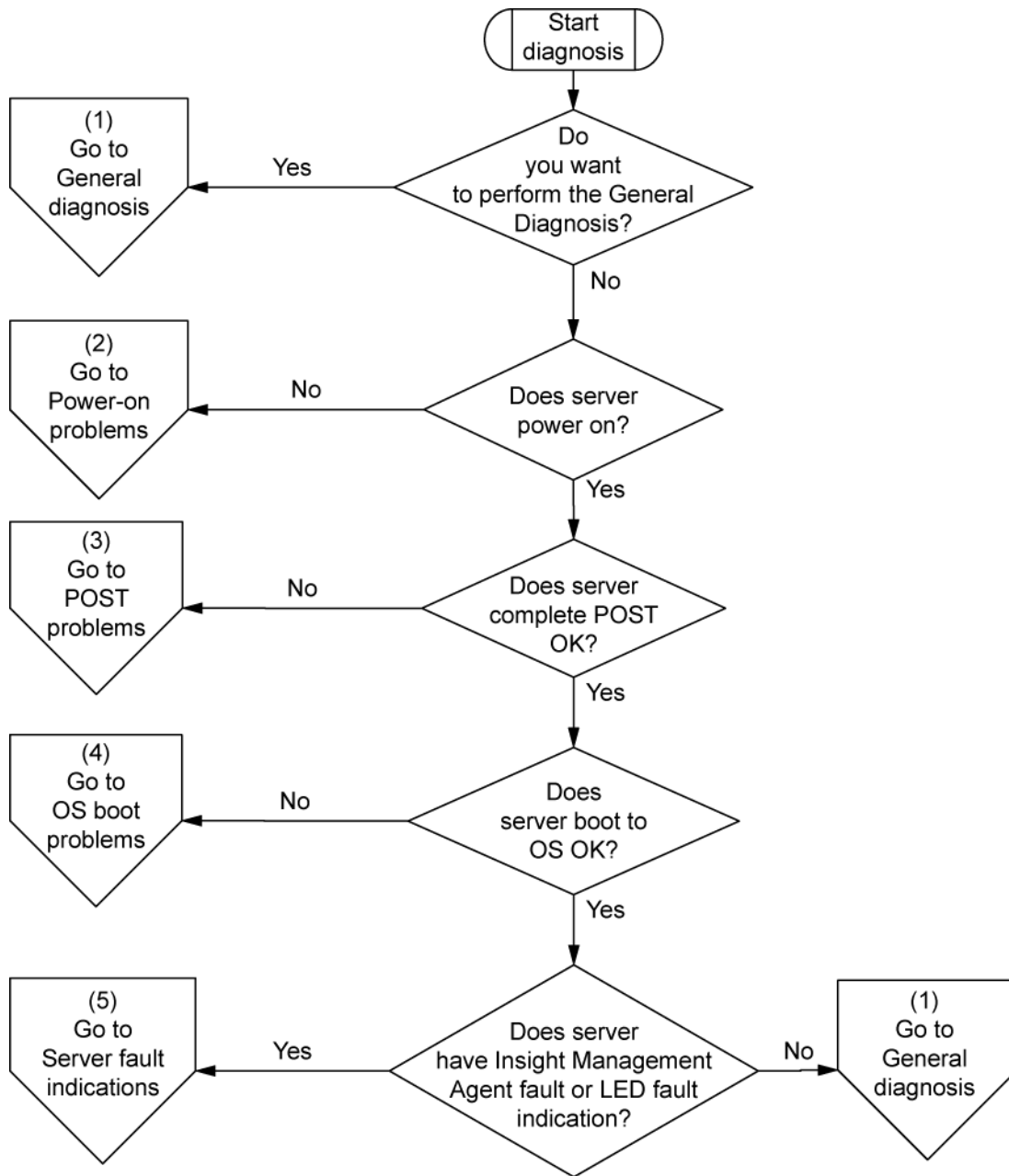

General diagnosis flowchart

The General diagnosis flowchart provides a generic approach to troubleshooting. If you are unsure of the problem, or if the other flowcharts do not fix the problem, use the following flowchart.

Item	Refer to
1	"Symptom information (on page 88)"
2	"Loose connections (on page 89)"
3	"Service notifications (on page 90)"
4	The most recent version of a particular server or option firmware is available on the HP Support website (http://www.hp.com/support).

Item	Refer to
5	"General memory problems are occurring" in the <i>HP ProLiant Servers Troubleshooting Guide</i> located on the Documentation CD or on the HP website (http://www.hp.com/support)
6	Server maintenance and service guide, located on the Documentation CD or the HP website (http://www.hp.com/products/servers/platforms)
7	<ul style="list-style-type: none"> • Server maintenance and service guide, located on the Documentation CD or the HP website (http://www.hp.com/products/servers/platforms) • "Hardware problems" in the <i>HP ProLiant Servers Troubleshooting Guide</i> located on the Documentation CD or on the HP website (http://www.hp.com/support)
8	<ul style="list-style-type: none"> • "Server information you need" in the <i>HP ProLiant Servers Troubleshooting Guide</i> located on the Documentation CD or on the HP website (http://www.hp.com/support) • "Operating system information you need" in the <i>HP ProLiant Servers Troubleshooting Guide</i> located on the Documentation CD or on the HP website (http://www.hp.com/support)
9	"HP contact information (on page 115)"

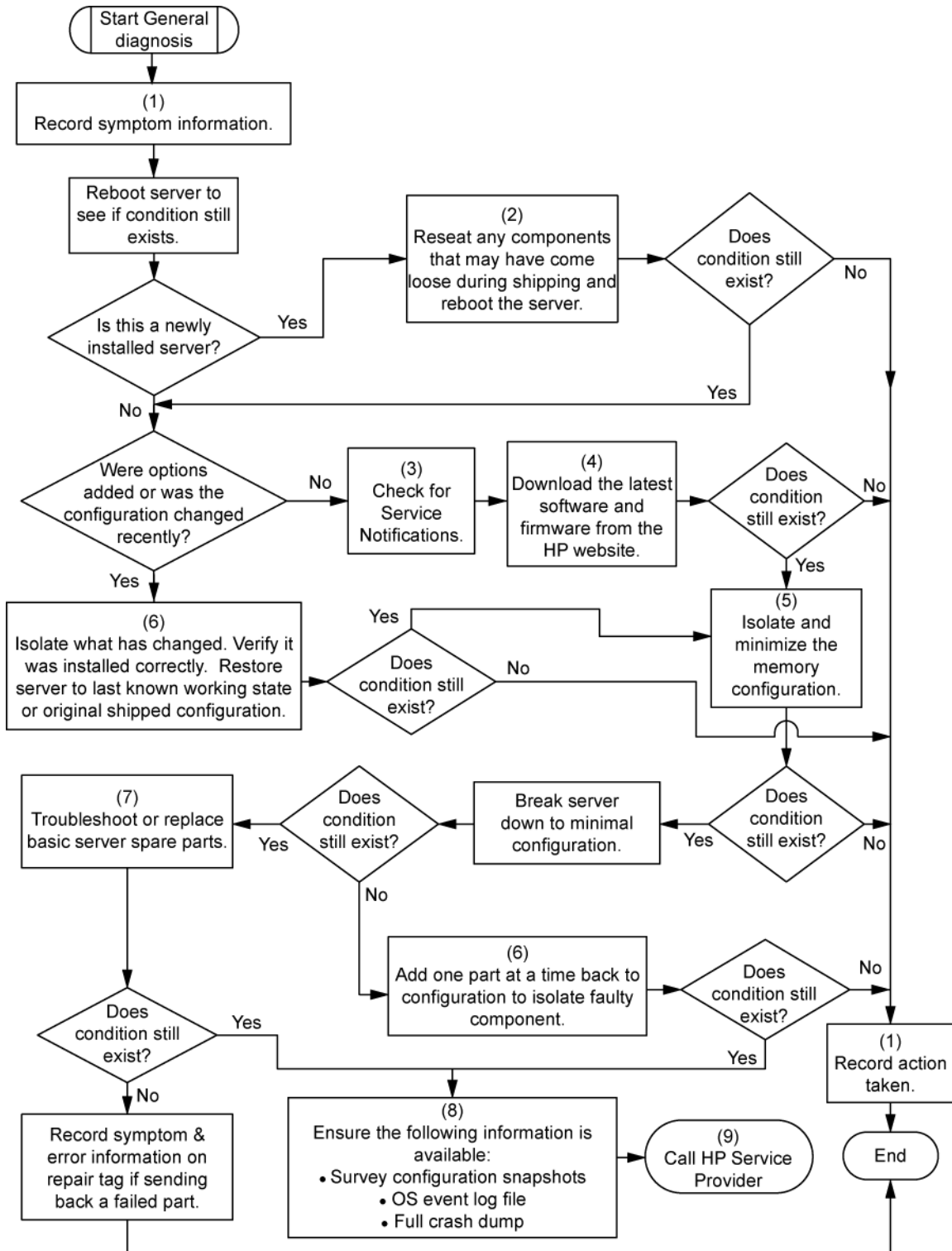

Server power-on problems flowchart

Symptoms:

- The server does not power on.
- The system power LED is off or amber.

- The external health LED is red or amber.
- The internal health LED is red or amber.

NOTE: For the location of server LEDs and information on their statuses, refer to the server documentation.

Possible causes:

- Improperly seated or faulty power supply
- Loose or faulty power cord
- Power source problem
- Power on circuit problem
- Improperly seated component or interlock problem
- Faulty internal component

Item	Refer to
1	"Component identification (on page 7)"
2	"HP Insight Diagnostics (on page 81)" or in the <i>HP ProLiant Servers Troubleshooting Guide</i> located on the Documentation CD or on the HP website (http://www.hp.com/support)
3	"Loose connections (on page 89)"
4	Server maintenance and service guide, located on the Documentation CD, or the HP website (http://www.hp.com/products/servers/platforms)
5	"Integrated Management Log (on page 82)" or in the <i>HP ProLiant Servers Troubleshooting Guide</i> located on the Documentation CD or on the HP website (http://www.hp.com/support)
6	"Power source problems" in the <i>HP ProLiant Servers Troubleshooting Guide</i> located on the Documentation CD or on the HP website (http://www.hp.com/support)
7	<ul style="list-style-type: none"> • "Power supply problems" in the <i>HP ProLiant Servers Troubleshooting Guide</i> located on the Documentation CD or on the HP website (http://www.hp.com/support) • Server maintenance and service guide, located on the Documentation CD, or the HP website (http://www.hp.com/products/servers/platforms)
8	"System open circuits and short circuits" in the <i>HP ProLiant Servers Troubleshooting Guide</i> located on the Documentation CD or on the HP website (http://www.hp.com/support)

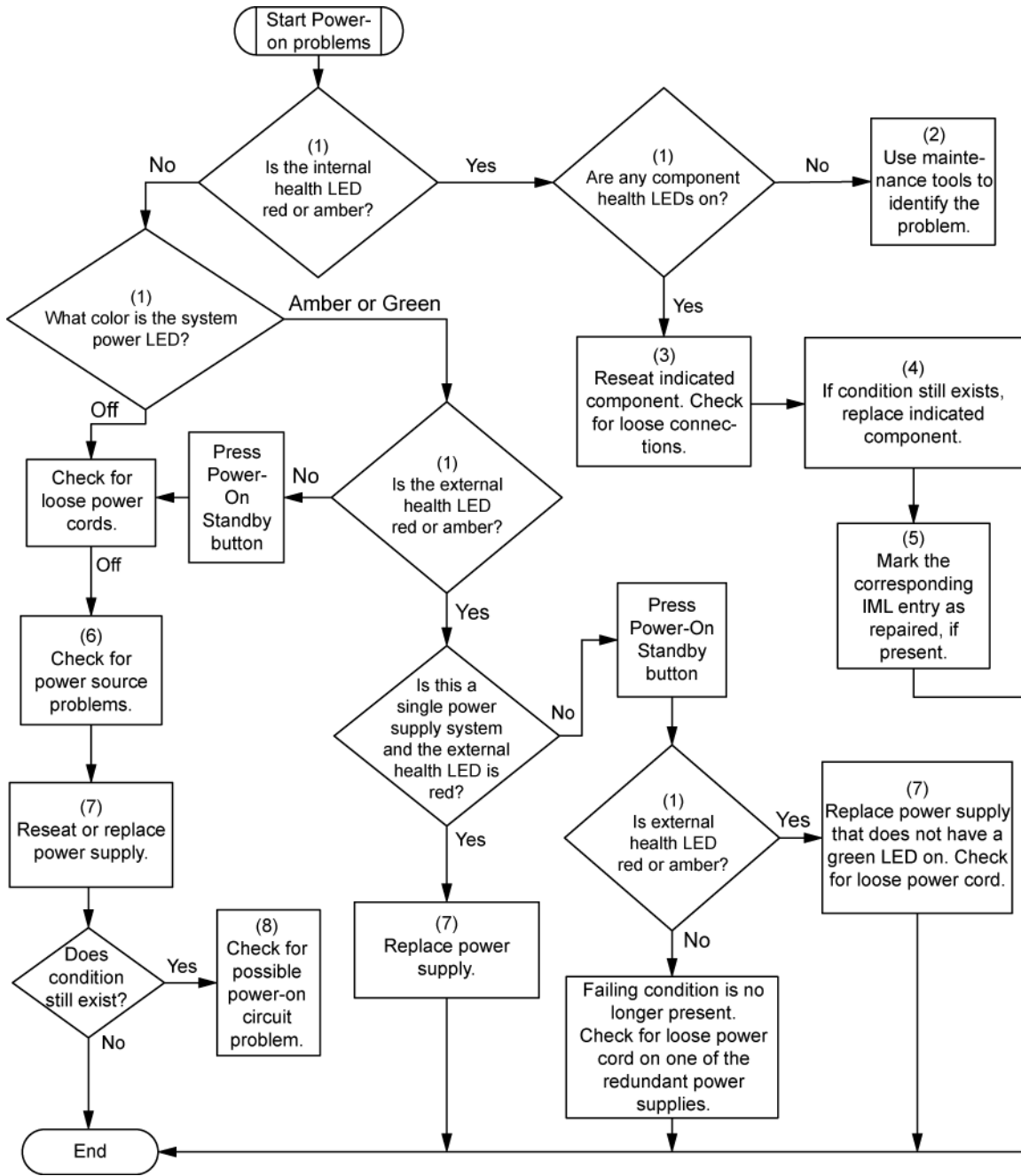

POST problems flowchart

Symptoms:

- Server does not complete POST

NOTE: The server has completed POST when the system attempts to access the boot device.

- Server completes POST with errors

Possible problems:

- Improperly seated or faulty internal component
- Faulty KVM device
- Faulty video device

Item	Refer to
1	"POST error messages and beep codes (on page 101)"
2	"Video problems" in the <i>HP ProLiant Servers Troubleshooting Guide</i> located on the Documentation CD or on the HP website (http://www.hp.com/support)
3	KVM or iLO 3 documentation
4	"Loose connections (on page 89)"
5	"Symptom information (on page 88)"
6	Server maintenance and service guide, located on the Documentation CD or the HP website (http://www.hp.com/products/servers/platforms)
7	"Port 85 and iLO messages" in the <i>HP ProLiant Servers Troubleshooting Guide</i> located on the Documentation CD or on the HP website (http://www.hp.com/support)
8	"General memory problems are occurring" in the <i>HP ProLiant Servers Troubleshooting Guide</i> located on the Documentation CD or on the HP website (http://www.hp.com/support)
9	<ul style="list-style-type: none"> • "Hardware problems" in the <i>HP ProLiant Servers Troubleshooting Guide</i> located on the Documentation CD or on the HP website (http://www.hp.com/support) • Server maintenance and service guide, located on the Documentation CD or the HP website (http://www.hp.com/products/servers/platforms)
10	<ul style="list-style-type: none"> • "Server information you need" in the <i>HP ProLiant Servers Troubleshooting Guide</i> located on the Documentation CD or on the HP website (http://www.hp.com/support) • "Operating system information you need" in the <i>HP ProLiant Servers Troubleshooting Guide</i> located on the Documentation CD or on the HP website (http://www.hp.com/support)

Item	Refer to
------	----------

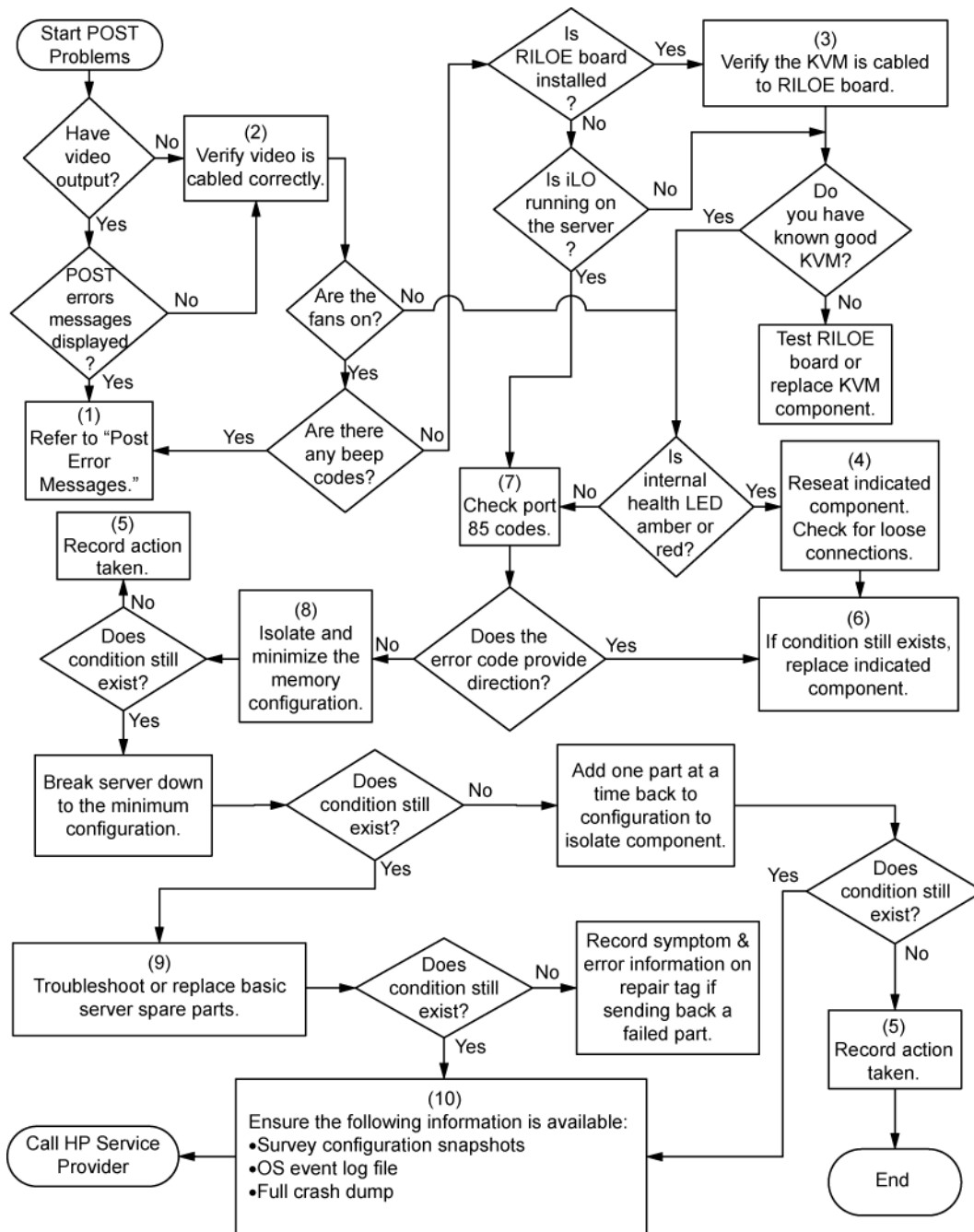

OS boot problems flowchart

Symptoms:

- Server does not boot a previously installed operating system

- Server does not boot SmartStart

Possible causes:

- Corrupted operating system
- Hard drive subsystem problem
- Incorrect boot order setting in RBSU

Item	Refer to
1	<i>HP ROM-Based Setup Utility User Guide</i> (http://www.hp.com/servers/smartstart)
2	"POST problems flowchart (on page 96)"
3	<ul style="list-style-type: none"> • "Hard drive problems" in the <i>HP ProLiant Servers Troubleshooting Guide</i> located on the Documentation CD or on the HP website (http://www.hp.com/support) • Controller documentation
4	"HP Insight Diagnostics (on page 81)" or in the <i>HP ProLiant Servers Troubleshooting Guide</i> located on the Documentation CD or on the HP website (http://www.hp.com/support)
5	<ul style="list-style-type: none"> • "CD-ROM and DVD drive problems" in the <i>HP ProLiant Servers Troubleshooting Guide</i> located on the Documentation CD or on the HP website (http://www.hp.com/support) • Controller documentation • "Loose connections (on page 89)"
6	"General memory problems are occurring" in the <i>HP ProLiant Servers Troubleshooting Guide</i> located on the Documentation CD or on the HP website (http://www.hp.com/support)
7	<ul style="list-style-type: none"> • "Operating system problems" in the <i>HP ProLiant Servers Troubleshooting Guide</i> located on the Documentation CD or on the HP website (http://www.hp.com/support) • "HP contact information (on page 115)"
8	<ul style="list-style-type: none"> • "Hardware problems" in the <i>HP ProLiant Servers Troubleshooting Guide</i> located on the Documentation CD or on the HP website (http://www.hp.com/support) • Server maintenance and service guide, located on the Documentation CD or the HP website (http://www.hp.com/products/servers/platforms)
9	"General diagnosis flowchart (on page 91)"

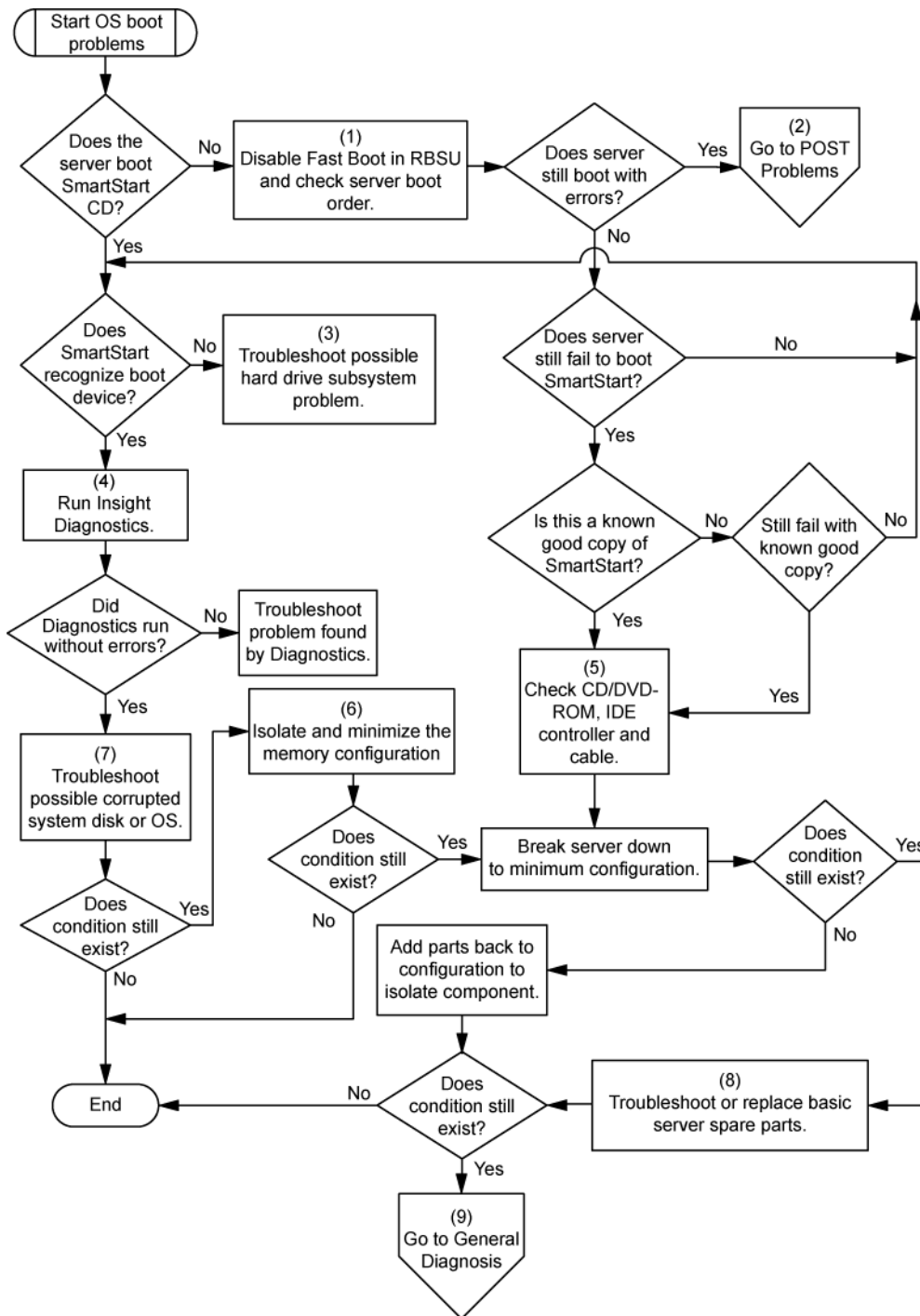

Server fault indications flowchart

Symptoms:

- Server boots, but a fault event is reported by Insight Management Agents
- Server boots, but the internal health LED, external health LED, or component health LED is red or amber

NOTE: For the location of server LEDs and information on their statuses, refer to the server documentation.

Possible causes:

- Improperly seated or faulty internal or external component
- Unsupported component installed
- Redundancy failure
- System overtemperature condition

Item	Refer to
1	"Management agents" or in the <i>HP ProLiant Servers Troubleshooting Guide</i> located on the Documentation CD or on the HP website (http://www.hp.com/support)
2	<ul style="list-style-type: none">• "Integrated Management Log (on page 82)" or in the <i>HP ProLiant Servers Troubleshooting Guide</i> located on the Documentation CD or on the HP website (http://www.hp.com/support)• "Event list error messages" in the <i>HP ProLiant Servers Troubleshooting Guide</i> located on the Documentation CD or on the HP website (http://www.hp.com/support)
3	"Component identification (on page 7)"
4	System Management Homepage (https://localhost:2381)
5	"Power-on problems flowchart ("Server power-on problems flowchart" on page 93)"
6	<ul style="list-style-type: none">• "Smart Array SCSI Diagnosis feature" in the <i>HP ProLiant Servers Troubleshooting Guide</i> located on the Documentation CD or on the HP website (http://www.hp.com/support)• Server maintenance and service guide, located on the Documentation CD or the HP website (http://www.hp.com/products/servers/platforms)• "HP contact information (on page 115)"
7	"HP Insight Diagnostics (on page 81)" or in the <i>HP ProLiant Servers Troubleshooting Guide</i> located on the Documentation CD or on the HP website (http://www.hp.com/support)
8	<ul style="list-style-type: none">• "Hardware problems" in the <i>HP ProLiant Servers Troubleshooting Guide</i> located on the Documentation CD or on the HP website (http://www.hp.com/support)• Server maintenance and service guide, located on the Documentation CD or the HP website (http://www.hp.com/products/servers/platforms)

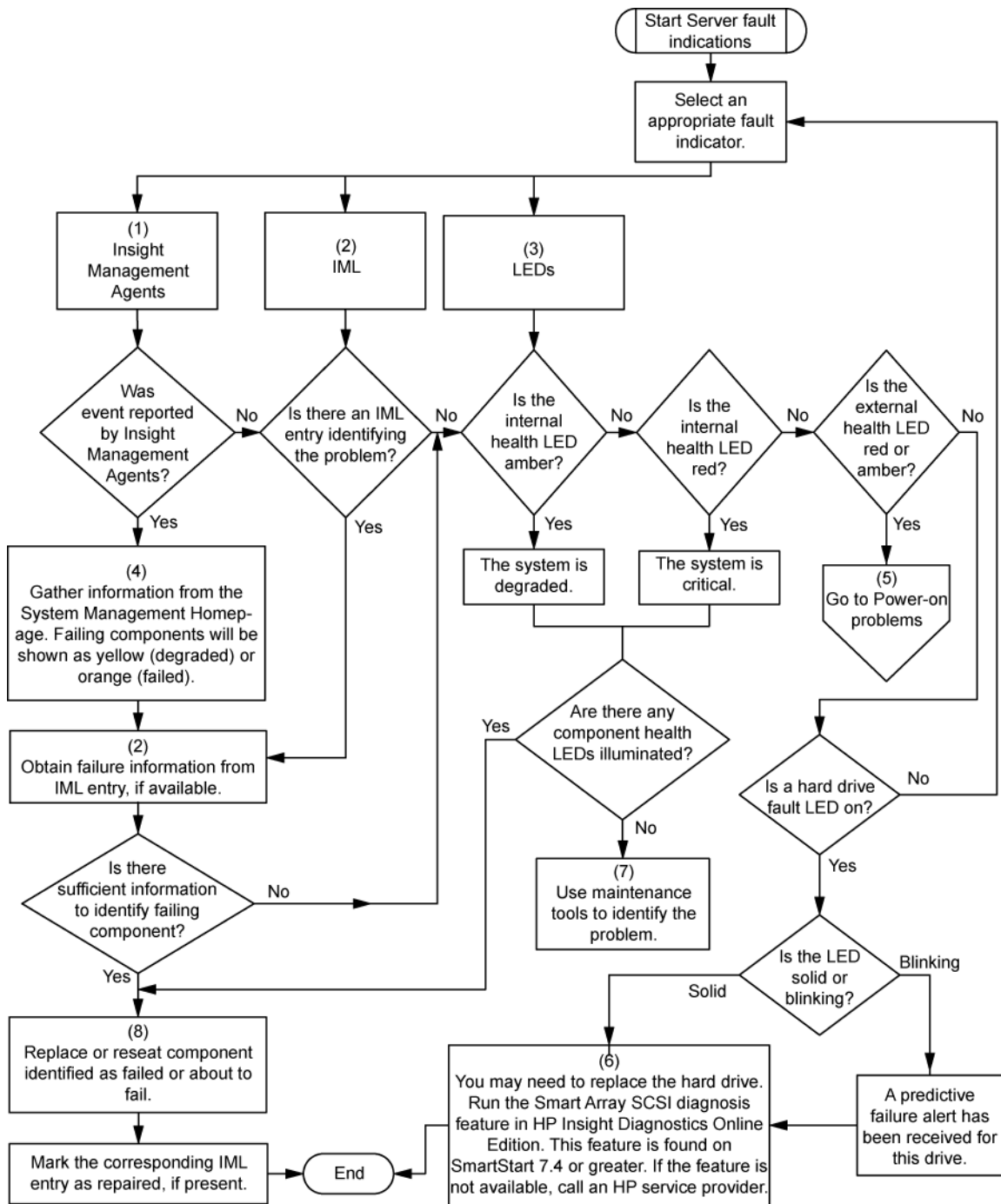

POST error messages and beep codes

For a complete listing of error messages, refer to the "POST error messages" in the *HP ProLiant Servers Troubleshooting Guide* located on the Documentation CD or on the HP website (<http://www.hp.com/support>).

⚠ WARNING: To avoid potential problems, ALWAYS read the warnings and cautionary information in the server documentation before removing, replacing, reseating, or modifying system components.

System battery

If the server no longer automatically displays the correct date and time, you may need to replace the battery that provides power to the real-time clock. Under normal use, battery life is 5 to 10 years.



WARNING: The computer contains an internal lithium manganese dioxide, a vanadium pentoxide, or an alkaline battery pack. A risk of fire and burns exists if the battery pack is not properly handled. To reduce the risk of personal injury:

- Do not attempt to recharge the battery.
- Do not expose the battery to temperatures higher than 60°C (140°F).
- Do not disassemble, crush, puncture, short external contacts, or dispose of in fire or water.
- Replace only with the spare designated for this product.

To remove the component:

1. Power down the server (on page 19).
2. Extend or remove the server from the rack ("Extend the server from the rack" on page 19).
3. Remove the access panel (on page 21).
4. If installed, remove the BBWC battery pack or the FBWC capacitor pack (on page 21).
5. Remove the air baffle (on page 22).
6. Locate the battery on the system board ("System board components" on page 11).
7. Remove the battery.

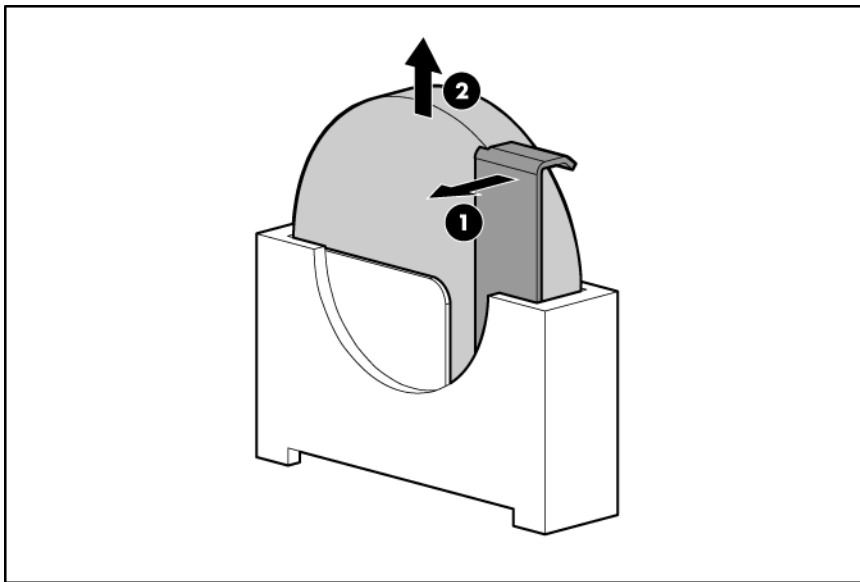

IMPORTANT: Replacing the system board battery resets the system ROM to its default configuration. After replacing the battery, reconfigure the system through RBSU.

To replace the component, reverse the removal procedure.

For more information about battery replacement or proper disposal, contact an authorized reseller or an authorized service provider.

Regulatory compliance notices

Regulatory compliance identification numbers

For the purpose of regulatory compliance certifications and identification, this product has been assigned a unique regulatory model number. The regulatory model number can be found on the product nameplate label, along with all required approval markings and information. When requesting compliance information for this product, always refer to this regulatory model number. The regulatory model number is not the marketing name or model number of the product.

Federal Communications Commission notice

Part 15 of the Federal Communications Commission (FCC) Rules and Regulations has established Radio Frequency (RF) emission limits to provide an interference-free radio frequency spectrum. Many electronic devices, including computers, generate RF energy incidental to their intended function and are, therefore, covered by these rules. These rules place computers and related peripheral devices into two classes, A and B, depending upon their intended installation. Class A devices are those that may reasonably be expected to be installed in a business or commercial environment. Class B devices are those that may reasonably be expected to be installed in a residential environment (for example, personal computers). The FCC requires devices in both classes to bear a label indicating the interference potential of the device as well as additional operating instructions for the user.

FCC rating label

The FCC rating label on the device shows the classification (A or B) of the equipment. Class B devices have an FCC logo or ID on the label. Class A devices do not have an FCC logo or ID on the label. After you determine the class of the device, refer to the corresponding statement.

Class A equipment

This equipment has been tested and found to comply with the limits for a Class A digital device, pursuant to Part 15 of the FCC Rules. These limits are designed to provide reasonable protection against harmful interference when the equipment is operated in a commercial environment. This equipment generates, uses, and can radiate radio frequency energy and, if not installed and used in accordance with the instructions, may cause harmful interference to radio communications. Operation of this equipment in a residential area is likely to cause harmful interference, in which case the user will be required to correct the interference at personal expense.

Class B equipment

This equipment has been tested and found to comply with the limits for a Class B digital device, pursuant to Part 15 of the FCC Rules. These limits are designed to provide reasonable protection against harmful interference in a residential installation. This equipment generates, uses, and can radiate radio frequency energy and, if not installed and used in accordance with the instructions, may cause harmful interference

to radio communications. However, there is no guarantee that interference will not occur in a particular installation. If this equipment does cause harmful interference to radio or television reception, which can be determined by turning the equipment off and on, the user is encouraged to try to correct the interference by one or more of the following measures:

- Reorient or relocate the receiving antenna.
- Increase the separation between the equipment and receiver.
- Connect the equipment into an outlet on a circuit that is different from that to which the receiver is connected.
- Consult the dealer or an experienced radio or television technician for help.

Declaration of conformity for products marked with the FCC logo, United States only

This device complies with Part 15 of the FCC Rules. Operation is subject to the following two conditions: (1) this device may not cause harmful interference, and (2) this device must accept any interference received, including interference that may cause undesired operation.

For questions regarding this product, contact us by mail or telephone:

- Hewlett-Packard Company
P. O. Box 692000, Mail Stop 530113
Houston, Texas 77269-2000
- 1-800-HP-INVENT (1-800-474-6836). (For continuous quality improvement, calls may be recorded or monitored.)

For questions regarding this FCC declaration, contact us by mail or telephone:

- Hewlett-Packard Company
P. O. Box 692000, Mail Stop 510101
Houston, Texas 77269-2000
- 1-281-514-3333

To identify this product, refer to the part, series, or model number found on the product.

Modifications

The FCC requires the user to be notified that any changes or modifications made to this device that are not expressly approved by Hewlett-Packard Company may void the user's authority to operate the equipment.

Cables

Connections to this device must be made with shielded cables with metallic RFI/EMI connector hoods in order to maintain compliance with FCC Rules and Regulations.

Canadian notice (Avis Canadien)

Class A equipment

This Class A digital apparatus meets all requirements of the Canadian Interference-Causing Equipment Regulations.

Cet appareil numérique de la classe A respecte toutes les exigences du Règlement sur le matériel brouilleur du Canada.

Class B equipment

This Class B digital apparatus meets all requirements of the Canadian Interference-Causing Equipment Regulations.

Cet appareil numérique de la classe B respecte toutes les exigences du Règlement sur le matériel brouilleur du Canada.

European Union regulatory notice

Products bearing the CE marking comply with the following EU Directives:

- Low Voltage Directive 2006/95/EC
- EMC Directive 2004/108/EC
- Ecodesign Directive 2009/125/EC, where applicable

CE compliance of this product is valid if powered with the correct CE-marked AC adapter provided by HP.

Compliance with these directives implies conformity to applicable harmonized European standards (European Norms) that are listed in the EU Declaration of Conformity issued by HP for this product or product family and available (in English only) either within the product documentation or at the following HP website (<http://www.hp.eu/certificates>) (type the product number in the search field).

The compliance is indicated by one of the following conformity markings placed on the product:

For non-telecommunications products and for EU harmonized telecommunications products, such as Bluetooth® within power class below 10mW.



For EU non-harmonized telecommunications products (If applicable, a 4-digit notified body number is inserted between CE and !).



Please refer to the regulatory label provided on the product.

The point of contact for regulatory matters is Hewlett-Packard GmbH, Dept./MS: HQ-TRE, Herrenberger Strasse 140, 71034 Boeblingen, GERMANY.

Disposal of waste equipment by users in private households in the European Union



This symbol on the product or on its packaging indicates that this product must not be disposed of with your other household waste. Instead, it is your responsibility to dispose of your waste equipment by handing it over to a designated collection point for the recycling of waste electrical and electronic equipment. The separate collection and recycling of your waste equipment at the time of disposal will help to conserve natural resources and ensure that it is recycled in a manner that protects human health and the environment. For more information about where you can drop off your waste equipment for recycling, please contact your local city office, your household waste disposal service or the shop where you purchased the product.

Japanese notice

ご使用になっている装置にVCCIマークが付いていましたら、次の説明文をお読み下さい。

この装置は、クラスB情報技術装置です。この装置は、家庭環境で使用することを目的としていますが、この装置がラジオやテレビジョン受信機に近接して使用されると、受信障害を引き起こすことがあります。取扱説明書に従って正しい取り扱いをして下さい。

VCCI-B

VCCIマークが付いていない場合には、次の点にご注意下さい。

この装置は、クラスA情報技術装置です。この装置を家庭環境で使用すると電波妨害を引き起こすことがあります。この場合には使用者は適切な対策を講ずるよう要求されることがあります。

VCCI-A

BSMI notice

警告使用者:

這是甲類的資訊產品，在居住的環境中使用時，可能會造成射頻干擾，在這種情況下，使用者會被要求採取某些適當的對策。

Korean notice

Class A equipment

A급 기기 (업무용 방송통신기기)	이 기기는 업무용(A급)으로 전자파적합등록을 한 기기이오니 판매자 또는 사용자는 이 점을 주의하시기 바라며, 가정 외의 지역에서 사용하는 것을 목적으로 합니다.
-----------------------	---

Class B equipment

B급 기기 (가정용 방송통신기기)	이 기기는 가정용(B급)으로 전자파적합등록을 한 기기로서 주로 가정에서 사용하는 것을 목적으로 하며, 모든 지역에서 사용할 수 있습니다.
-----------------------	--

Chinese notice

Class A equipment

声明

此为 A 级产品，在生活环境中，该产品可能会造成无线电干扰。在这种情况下，可能需要用户对其干扰采取可行的措施。

Laser compliance

This product may be provided with an optical storage device (that is, CD or DVD drive) and/or fiber optic transceiver. Each of these devices contains a laser that is classified as a Class 1 Laser Product in accordance with US FDA regulations and the IEC 60825-1. The product does not emit hazardous laser radiation.

Each laser product complies with 21 CFR 1040.10 and 1040.11 except for deviations pursuant to Laser Notice No. 50, dated May 27, 2001; and with IEC 60825-1:1993/A2:2001.



WARNING: Use of controls or adjustments or performance of procedures other than those specified herein or in the laser product's installation guide may result in hazardous radiation exposure. To reduce the risk of exposure to hazardous radiation:

- Do not try to open the module enclosure. There are no user-serviceable components inside.
- Do not operate controls, make adjustments, or perform procedures to the laser device other than those specified herein.
- Allow only HP Authorized Service technicians to repair the unit.

The Center for Devices and Radiological Health (CDRH) of the U.S. Food and Drug Administration implemented regulations for laser products on August 2, 1976. These regulations apply to laser products manufactured from August 1, 1976. Compliance is mandatory for products marketed in the United States.

Battery replacement notice



WARNING: The computer contains an internal lithium manganese dioxide, a vanadium pentoxide, or an alkaline battery pack. A risk of fire and burns exists if the battery pack is not properly handled. To reduce the risk of personal injury:

- Do not attempt to recharge the battery.
- Do not expose the battery to temperatures higher than 60°C (140°F).
- Do not disassemble, crush, puncture, short external contacts, or dispose of in fire or water.



Batteries, battery packs, and accumulators should not be disposed of together with the general household waste. To forward them to recycling or proper disposal, use the public collection system or return them to HP, an authorized HP Partner, or their agents.

For more information about battery replacement or proper disposal, contact an authorized reseller or an authorized service provider.

Taiwan battery recycling notice

The Taiwan EPA requires dry battery manufacturing or importing firms in accordance with Article 15 of the Waste Disposal Act to indicate the recovery marks on the batteries used in sales, giveaway or promotion. Contact a qualified Taiwanese recycler for proper battery disposal.



Power cord statement for Japan

製品には、同梱された電源コードをお使い下さい。
同梱された電源コードは、他の製品では使用出来ません。

Acoustics statement for Germany (Geräuschemission)

Schalldruckpegel $L_{pA} < 70$ dB(A)

Zuschauerpositionen (bystander positions), Normaler Betrieb (normal operation)

Nach ISO 7779:1999 (Typprüfung)

Electrostatic discharge

Preventing electrostatic discharge

To prevent damaging the system, be aware of the precautions you need to follow when setting up the system or handling parts. A discharge of static electricity from a finger or other conductor may damage system boards or other static-sensitive devices. This type of damage may reduce the life expectancy of the device.

To prevent electrostatic damage:

- Avoid hand contact by transporting and storing products in static-safe containers.
- Keep electrostatic-sensitive parts in their containers until they arrive at static-free workstations.
- Place parts on a grounded surface before removing them from their containers.
- Avoid touching pins, leads, or circuitry.
- Always be properly grounded when touching a static-sensitive component or assembly.

Grounding methods to prevent electrostatic discharge

Several methods are used for grounding. Use one or more of the following methods when handling or installing electrostatic-sensitive parts:

- Use a wrist strap connected by a ground cord to a grounded workstation or computer chassis. Wrist straps are flexible straps with a minimum of 1 megohm ± 10 percent resistance in the ground cords. To provide proper ground, wear the strap snug against the skin.
- Use heel straps, toe straps, or boot straps at standing workstations. Wear the straps on both feet when standing on conductive floors or dissipating floor mats.
- Use conductive field service tools.
- Use a portable field service kit with a folding static-dissipating work mat.

If you do not have any of the suggested equipment for proper grounding, have an authorized reseller install the part.

For more information on static electricity or assistance with product installation, contact an authorized reseller.

Specifications

Environmental specifications

Specification	Value
Temperature range*	
Operating	10°C to 35°C (50°F to 95°F)
Shipping	-40°C to 70°C (-40°F to 158°F)
Maximum wet bulb temperature	28°C (82.4°F)
Relative humidity (noncondensing)**	
Operating	10% to 90%
Non-operating	5% to 95%

* All temperature ratings shown are for sea level. An altitude derating of 1°C per 300 m (1.8°F per 1,000 ft) to 3048 m (10,000 ft) is applicable. No direct sunlight allowed.

** Storage maximum humidity of 95% is based on a maximum temperature of 45°C (113°F). Altitude maximum for storage corresponds to a pressure minimum of 70 kPa.

Server specifications

Specification	Value
Height	4.32 cm (1.70 in)
Depth	69.53 cm (27.38 in)
Width	42.62 cm (16.78 in)
Weight (maximum: two processors, two power supplies, eight hard drives)	15.97 kg (35.20 lb)
Weight (minimum: one processor, one power supply, no hard drives)	14.51 kg (32.00 lb)
Weight (no drives installed)	14.06 kg (31.00 lb)

Power supply specifications

Depending on installed options, the server is configured with one of the following power supplies:

- HP 460 W CS HE Power Supply (92%) specifications (on page [111](#))
- HP 460 W CS Platinum Power Supply (94%) specifications (on page [111](#))
- HP 750 W CS HE Power Supply (92%) specifications (on page [112](#))

- HP 750 W CS Platinum Power Supply (94%) specifications (on page 112)
- HP 1200 W CS HE Power Supply (90%) specifications (on page 113)
- HP 1200 W CS -48Vdc Power Supply specifications (on page 113)

HP 460 W CS HE Power Supply (92%) specifications

Specification	Value
Input requirements	
Rated input voltage	100 to 120 VAC, 200 to 240 VAC
Rated input frequency	50 Hz to 60 Hz
Rated input current	5.5 A at 100 VAC 2.6 A at 200 VAC
Rated input power	526 W at 100V AC input 505 W at 200V AC input
BTUs per hour	1794 at 100V AC input 1725 at 200V AC input
Power supply output	
Rated steady-state power	460 W at 100V to 120V AC input 460 W at 200V to 240V AC input
Maximum peak power	460 W at 100V to 120V AC input 460 W at 200V to 240V AC input

HP 460 W CS Platinum Power Supply (94%) specifications

Specification	Value
Input requirements	
Rated input voltage	100 to 120 VAC, 200 to 240 VAC
Rated input frequency	50 Hz to 60 Hz
Rated input current	5.3 A at 100 VAC 2.5 A at 200 VAC
Rated input power	512 W at 100V AC input 493 W at 200V AC input
BTUs per hour	1747 at 100V AC input 1683 at 200V AC input
Power supply output	
Rated steady-state power	460 W at 100V to 120V AC input

	460 W at 200V to 240V AC input
Maximum peak power	460 W at 100V to 120V AC input 460 W at 200V to 240V AC input

HP 750 W CS HE Power Supply (92%) specifications

Specification	Value
Input requirements	
Rated input voltage	100 to 120 VAC, 200 to 240 VAC
Rated input frequency	50 Hz to 60 Hz
Rated input current	8.9 A at 100 VAC 4.3 A at 200 VAC
Rated input power	857 W at 100V AC input 824 W at 200V AC input
BTUs per hour	2925 at 100V AC input 2812 at 200V AC input
Power supply output	
Rated steady-state power	750 W at 100V to 120V AC input 750 W at 200V to 240V AC input
Maximum peak power	750 W at 100V to 120V AC input 750 W at 200V to 240V AC input

HP 750 W CS Platinum Power Supply (94%) specifications

Specification	Value
Input requirements	
Rated input voltage	100 to 120 VAC, 200 to 240 VAC
Rated input frequency	50 Hz to 60 Hz
Rated input current	8.6 A at 100 VAC 4.2 A at 200 VAC
Maximum rated input power	841 W at 100V AC input 809 W at 200V AC input
BTUs per hour	2868 at 100V AC input 2761 at 200V AC input
Power supply output	

Rated steady-state power	750 W at 100V to 120V AC input 750 W at 200V to 240V AC input
Maximum peak power	750 W at 100V to 120V AC input 750 W at 200V to 240V AC input

HP 1200 W CS HE Power Supply (90%) specifications

Specification	Value
Input requirements	
Rated input voltage	100 to 120 VAC, 200 to 240 VAC
Rated input frequency	50 Hz to 60 Hz
Rated input current	9.7 A at 100 VAC 7.0 A at 200 VAC
Maximum rated input power	930 W at 100V AC input 1348 W at 200V AC input
BTUs per hour	3174 at 120V AC input 4600 at 200V to 240V AC input
Power supply output	
Rated steady-state power	800 W at 100V AC input 900 W at 120V AC input 1200 W at 200V to 240V AC input
Maximum peak power	800 W at 100V AC input 900 W at 120V AC input 1200 W at 200V to 240V AC input

HP 1200 W CS -48Vdc Power Supply specifications

Specification	Value
Input requirements	
Rated input voltage	-36V to -72V DC -48V DC, nominal input
Rated input frequency	Not applicable
Rated input current	38A at -36V DC 19A at -72V DC 28A at -48V DC, nominal input

Rated input power	1380 W at -36V DC input 1365 W at -72V DC input 1350 W at -48V DC, nominal input
BTUs per hour	4713 at -36V DC input 4662 at -72V DC input 4610 at -48V DC, nominal input
Power supply output	
Rated steady-state power	1200 W
Rated peak power	1200 W

△ **CAUTION:** This equipment is designed to permit the connection of the earthed conductor of the DC supply circuit to the earthing conductor at the equipment. See installation instructions.

△ **CAUTION:** This equipment is designed to permit the connection of the earthed conductor of the DC supply circuit to the earthing conductor at the equipment.

If this connection is made, all of the following must be met:

- This equipment should be connected directly to the DC supply system earthing electrode conductor or to a bonding jumper from an earthing terminal bar or bus to which the DC supply system earthing electrode conductor is connected.
 - This equipment should be located in the same immediate area (such as adjacent cabinets) as any other equipment that has a connection between the earthed conductor of the same DC supply circuit and the earthing conductor, and also the the point of earthing of the DC system. The DC system should be earthed elsewhere.
 - The DC supply source is to be located within the same premises as the equipment.
 - Switching or disconnecting devices should not be in the earthed circuit conductor between the DC source and the point of connection of the earthing electrode conductor.
-

△ **CAUTION:** To reduce the risk of electric shock or energy hazards:

- This equipment must be installed by trained service personnel, as defined by the NEC and IEC 60950-1, Second Edition, the standard for Safety of Information Technology Equipment.
 - Connect the equipment to a reliably grounded safety extra low voltage (SELV) source. An SELV source is a secondary circuit that is designed so normal and single fault conditions do not cause the voltages to exceed a safe level (60 V direct current).
 - The branch circuit overcurrent protection must be rated 20A.
-

Hot-plug power supply calculations

For hot-plug power supply specifications and calculators to determine electrical and heat loading for the server, refer to the HP Enterprise Configurator website (<http://h30099.www3.hp.com/configurator/>).

Technical support

Before you contact HP

Be sure to have the following information available before you call HP:

- Technical support registration number (if applicable)
- Product serial number
- Product model name and number
- Product identification number
- Applicable error messages
- Add-on boards or hardware
- Third-party hardware or software
- Operating system type and revision level

HP contact information

For the name of the nearest HP authorized reseller:

- See the Contact HP worldwide (in English) webpage (<http://welcome.hp.com/country/us/en/wwcontact.html>).

For HP technical support:

- In the United States, for contact options see the Contact HP United States webpage (http://welcome.hp.com/country/us/en/contact_us.html). To contact HP by phone:
 - Call 1-800-HP-INVENT (1-800-474-6836). This service is available 24 hours a day, 7 days a week. For continuous quality improvement, calls may be recorded or monitored.
 - If you have purchased a Care Pack (service upgrade), call 1-800-633-3600. For more information about Care Packs, refer to the HP website (<http://www.hp.com/hps>).
- In other locations, see the Contact HP worldwide (in English) webpage (<http://welcome.hp.com/country/us/en/wwcontact.html>).

Customer Self Repair

HP products are designed with many Customer Self Repair (CSR) parts to minimize repair time and allow for greater flexibility in performing defective parts replacement. If during the diagnosis period HP (or HP service providers or service partners) identifies that the repair can be accomplished by the use of a CSR part, HP will ship that part directly to you for replacement. There are two categories of CSR parts:

- **Mandatory**—Parts for which customer self repair is mandatory. If you request HP to replace these parts, you will be charged for the travel and labor costs of this service.

- **Optional**—Parts for which customer self repair is optional. These parts are also designed for customer self repair. If, however, you require that HP replace them for you, there may or may not be additional charges, depending on the type of warranty service designated for your product.

NOTE: Some HP parts are not designed for customer self repair. In order to satisfy the customer warranty, HP requires that an authorized service provider replace the part. These parts are identified as "No" in the Illustrated Parts Catalog.

Based on availability and where geography permits, CSR parts will be shipped for next business day delivery. Same day or four-hour delivery may be offered at an additional charge where geography permits. If assistance is required, you can call the HP Technical Support Center and a technician will help you over the telephone. HP specifies in the materials shipped with a replacement CSR part whether a defective part must be returned to HP. In cases where it is required to return the defective part to HP, you must ship the defective part back to HP within a defined period of time, normally five (5) business days. The defective part must be returned with the associated documentation in the provided shipping material. Failure to return the defective part may result in HP billing you for the replacement. With a customer self repair, HP will pay all shipping and part return costs and determine the courier/carrier to be used.

For more information about HP's Customer Self Repair program, contact your local service provider. For the North American program, refer to the HP website (<http://www.hp.com/go/selfrepair>).

Réparation par le client (CSR)

Les produits HP comportent de nombreuses pièces CSR (Customer Self Repair = réparation par le client) afin de minimiser les délais de réparation et faciliter le remplacement des pièces défectueuses. Si pendant la période de diagnostic, HP (ou ses partenaires ou mainteneurs agréés) détermine que la réparation peut être effectuée à l'aide d'une pièce CSR, HP vous l'envoie directement. Il existe deux catégories de pièces CSR:

Obligatoire - Pièces pour lesquelles la réparation par le client est obligatoire. Si vous demandez à HP de remplacer ces pièces, les coûts de déplacement et main d'œuvre du service vous seront facturés.

Facultatif - Pièces pour lesquelles la réparation par le client est facultative. Ces pièces sont également conçues pour permettre au client d'effectuer lui-même la réparation. Toutefois, si vous demandez à HP de remplacer ces pièces, l'intervention peut ou non vous être facturée, selon le type de garantie applicable à votre produit.

REMARQUE: Certaines pièces HP ne sont pas conçues pour permettre au client d'effectuer lui-même la réparation. Pour que la garantie puisse s'appliquer, HP exige que le remplacement de la pièce soit effectué par un Mainteneur Agréé. Ces pièces sont identifiées par la mention "Non" dans le Catalogue illustré.

Les pièces CSR sont livrées le jour ouvré suivant, dans la limite des stocks disponibles et selon votre situation géographique. Si votre situation géographique le permet et que vous demandez une livraison le jour même ou dans les 4 heures, celle-ci vous sera facturée. Pour bénéficier d'une assistance téléphonique, appelez le Centre d'assistance technique HP. Dans les documents envoyés avec la pièce de rechange CSR, HP précise s'il est nécessaire de lui retourner la pièce défectueuse. Si c'est le cas, vous devez le faire dans le délai indiqué, généralement cinq (5) jours ouvrés. La pièce et sa documentation doivent être retournées dans l'emballage fourni. Si vous ne retournez pas la pièce défectueuse, HP se réserve le droit de vous facturer les coûts de remplacement. Dans le cas d'une pièce CSR, HP supporte l'ensemble des frais d'expédition et de retour, et détermine la société de courses ou le transporteur à utiliser.

Pour plus d'informations sur le programme CSR de HP, contactez votre Mainteneur Agrée local. Pour plus d'informations sur ce programme en Amérique du Nord, consultez le site Web HP (<http://www.hp.com/go/selfrepair>).

Riparazione da parte del cliente

Per abbreviare i tempi di riparazione e garantire una maggiore flessibilità nella sostituzione di parti difettose, i prodotti HP sono realizzati con numerosi componenti che possono essere riparati direttamente dal cliente (CSR, Customer Self Repair). Se in fase di diagnostica HP (o un centro di servizi o di assistenza HP) identifica il guasto come riparabile mediante un ricambio CSR, HP lo spedisce direttamente al cliente per la sostituzione. Vi sono due categorie di parti CSR:

Obbligatorie – Parti che devono essere necessariamente riparate dal cliente. Se il cliente ne affida la riparazione ad HP, deve sostenere le spese di spedizione e di manodopera per il servizio.

Opzionali – Parti la cui riparazione da parte del cliente è facoltativa. Si tratta comunque di componenti progettati per questo scopo. Se tuttavia il cliente ne richiede la sostituzione ad HP, potrebbe dover sostenere spese aggiuntive a seconda del tipo di garanzia previsto per il prodotto.

NOTA: alcuni componenti HP non sono progettati per la riparazione da parte del cliente. Per rispettare la garanzia, HP richiede che queste parti siano sostituite da un centro di assistenza autorizzato. Tali parti sono identificate da un "No" nel Catalogo illustrato dei componenti.

In base alla disponibilità e alla località geografica, le parti CSR vengono spedite con consegna entro il giorno lavorativo seguente. La consegna nel giorno stesso o entro quattro ore è offerta con un supplemento di costo solo in alcune zone. In caso di necessità si può richiedere l'assistenza telefonica di un addetto del centro di supporto tecnico HP. Nel materiale fornito con una parte di ricambio CSR, HP specifica se il cliente deve restituire dei componenti. Qualora sia richiesta la resa ad HP del componente difettoso, lo si deve spedire ad HP entro un determinato periodo di tempo, generalmente cinque (5) giorni lavorativi. Il componente difettoso deve essere restituito con la documentazione associata nell'imballo di spedizione fornito. La mancata restituzione del componente può comportare la fatturazione del ricambio da parte di HP. Nel caso di riparazione da parte del cliente, HP sostiene tutte le spese di spedizione e resa e sceglie il corriere/vettore da utilizzare.

Per ulteriori informazioni sul programma CSR di HP contattare il centro di assistenza di zona. Per il programma in Nord America fare riferimento al sito Web HP (<http://www.hp.com/go/selfrepair>).

Customer Self Repair

HP Produkte enthalten viele CSR-Teile (Customer Self Repair), um Reparaturzeiten zu minimieren und höhere Flexibilität beim Austausch defekter Bauteile zu ermöglichen. Wenn HP (oder ein HP Servicepartner) bei der Diagnose feststellt, dass das Produkt mithilfe eines CSR-Teils repariert werden kann, sendet Ihnen HP dieses Bauteil zum Austausch direkt zu. CSR-Teile werden in zwei Kategorien unterteilt:

Zwingend – Teile, für die das Customer Self Repair-Verfahren zwingend vorgegeben ist. Wenn Sie den Austausch dieser Teile von HP vornehmen lassen, werden Ihnen die Anfahrt- und Arbeitskosten für diesen Service berechnet.

Optional – Teile, für die das Customer Self Repair-Verfahren optional ist. Diese Teile sind auch für Customer Self Repair ausgelegt. Wenn Sie jedoch den Austausch dieser Teile von HP vornehmen lassen möchten, können bei diesem Service je nach den für Ihr Produkt vorgesehenen Garantiebedingungen zusätzliche Kosten anfallen.

HINWEIS: Einige Teile sind nicht für Customer Self Repair ausgelegt. Um den Garantieanspruch des Kunden zu erfüllen, muss das Teil von einem HP Servicepartner ersetzt werden. Im illustrierten Teilekatalog sind diese Teile mit „No“ bzw. „Nein“ gekennzeichnet.

CSR-Teile werden abhängig von der Verfügbarkeit und vom Lieferziel am folgenden Geschäftstag geliefert. Für bestimmte Standorte ist eine Lieferung am selben Tag oder innerhalb von vier Stunden gegen einen Aufpreis verfügbar. Wenn Sie Hilfe benötigen, können Sie das HP technische Support Center anrufen und sich von einem Mitarbeiter per Telefon helfen lassen. Den Materialien, die mit einem CSR-Ersatzteil geliefert werden, können Sie entnehmen, ob das defekte Teil an HP zurückgeschickt werden muss. Wenn es erforderlich ist, das defekte Teil an HP zurückzuschicken, müssen Sie dies innerhalb eines vorgegebenen Zeitraums tun, in der Regel innerhalb von fünf (5) Geschäftstagen. Das defekte Teil muss mit der zugehörigen Dokumentation in der Verpackung zurückgeschickt werden, die im Lieferumfang enthalten ist. Wenn Sie das defekte Teil nicht zurückschicken, kann HP Ihnen das Ersatzteil in Rechnung stellen. Im Falle von Customer Self Repair kommt HP für alle Kosten für die Lieferung und Rücksendung auf und bestimmt den Kurier-/Frachtdienst.

Weitere Informationen über das HP Customer Self Repair Programm erhalten Sie von Ihrem Servicepartner vor Ort. Informationen über das CSR-Programm in Nordamerika finden Sie auf der HP Website unter (<http://www.hp.com/go/selfrepair>).

Reparaciones del propio cliente

Los productos de HP incluyen muchos componentes que el propio usuario puede reemplazar (*Customer Self Repair*, CSR) para minimizar el tiempo de reparación y ofrecer una mayor flexibilidad a la hora de realizar sustituciones de componentes defectuosos. Si, durante la fase de diagnóstico, HP (o los proveedores o socios de servicio de HP) identifica que una reparación puede llevarse a cabo mediante el uso de un componente CSR, HP le enviará dicho componente directamente para que realice su sustitución. Los componentes CSR se clasifican en dos categorías:

- **Obligatorio:** componentes para los que la reparación por parte del usuario es obligatoria. Si solicita a HP que realice la sustitución de estos componentes, tendrá que hacerse cargo de los gastos de desplazamiento y de mano de obra de dicho servicio.
- **Opcional:** componentes para los que la reparación por parte del usuario es opcional. Estos componentes también están diseñados para que puedan ser reparados por el usuario. Sin embargo, si precisa que HP realice su sustitución, puede o no conllevar costes adicionales, dependiendo del tipo de servicio de garantía correspondiente al producto.

NOTA: Algunos componentes no están diseñados para que puedan ser reparados por el usuario. Para que el usuario haga valer su garantía, HP pone como condición que un proveedor de servicios autorizado realice la sustitución de estos componentes. Dichos componentes se identifican con la palabra "No" en el catálogo ilustrado de componentes.

Según la disponibilidad y la situación geográfica, los componentes CSR se enviarán para que lleguen a su destino al siguiente día laborable. Si la situación geográfica lo permite, se puede solicitar la entrega en el mismo día o en cuatro horas con un coste adicional. Si precisa asistencia técnica, puede llamar al Centro de asistencia técnica de HP y recibirá ayuda telefónica por parte de un técnico. Con el envío de materiales para la sustitución de componentes CSR, HP especificará si los componentes defectuosos deberán devolverse a HP. En aquellos casos en los que sea necesario devolver algún componente a HP, deberá hacerlo en el periodo de tiempo especificado, normalmente cinco días laborables. Los componentes defectuosos deberán devolverse con toda la documentación relacionada y con el embalaje de envío. Si no enviara el componente defectuoso requerido, HP podrá cobrarle por el de sustitución. En

el caso de todas sustituciones que lleve a cabo el cliente, HP se hará cargo de todos los gastos de envío y devolución de componentes y escogerá la empresa de transporte que se utilice para dicho servicio.

Para obtener más información acerca del programa de Reparaciones del propio cliente de HP, póngase en contacto con su proveedor de servicios local. Si está interesado en el programa para Norteamérica, visite la página web de HP siguiente (<http://www.hp.com/go/selfrepair>).

Customer Self Repair

Veel onderdelen in HP producten zijn door de klant zelf te repareren, waardoor de reparatieduur tot een minimum beperkt kan blijven en de flexibiliteit in het vervangen van defecte onderdelen groter is. Deze onderdelen worden CSR-onderdelen (Customer Self Repair) genoemd. Als HP (of een HP Service Partner) bij de diagnose vaststelt dat de reparatie kan worden uitgevoerd met een CSR-onderdeel, verzendt HP dat onderdeel rechtstreeks naar u, zodat u het defecte onderdeel daarmee kunt vervangen. Er zijn twee categorieën CSR-onderdelen:

Verplicht: Onderdelen waarvoor reparatie door de klant verplicht is. Als u HP verzoekt deze onderdelen voor u te vervangen, worden u voor deze service reiskosten en arbeidsloon in rekening gebracht.

Optioneel: Onderdelen waarvoor reparatie door de klant optioneel is. Ook deze onderdelen zijn ontworpen voor reparatie door de klant. Als u echter HP verzoekt deze onderdelen voor u te vervangen, kunnen daarvoor extra kosten in rekening worden gebracht, afhankelijk van het type garanteservice voor het product.

OPMERKING: Sommige HP onderdelen zijn niet ontwikkeld voor reparatie door de klant. In verband met de garantievoorwaarden moet het onderdeel door een geautoriseerde Service Partner worden vervangen. Deze onderdelen worden in de geïllustreerde onderdelencatalogus aangemerkt met "Nee".

Afhankelijk van de leverbaarheid en de locatie worden CSR-onderdelen verzonden voor levering op de eerstvolgende werkdag. Levering op dezelfde dag of binnen vier uur kan tegen meerkosten worden aangeboden, indien dit mogelijk is gezien de locatie. Indien assistentie gewenst is, belt u een HP Service Partner om via de telefoon technische ondersteuning te ontvangen. HP vermeldt in de documentatie bij het vervangende CSR-onderdeel of het defecte onderdeel aan HP moet worden geretourneerd. Als het defecte onderdeel aan HP moet worden teruggezonden, moet u het defecte onderdeel binnen een bepaalde periode, gewoonlijk vijf (5) werkdagen, retourneren aan HP. Het defecte onderdeel moet met de bijbehorende documentatie worden geretourneerd in het meegeleverde verpakkingsmateriaal. Als u het defecte onderdeel niet terugzendt, kan HP u voor het vervangende onderdeel kosten in rekening brengen. Bij reparatie door de klant betaalt HP alle verzendkosten voor het vervangende en geretourneerde onderdeel en kiest HP zelf welke koerier/transportonderneming hiervoor wordt gebruikt.

Neem contact op met een Service Partner voor meer informatie over het Customer Self Repair programma van HP. Informatie over Service Partners vindt u op de HP website (<http://www.hp.com/go/selfrepair>).

Reparo feito pelo cliente

Os produtos da HP são projetados com muitas peças para reparo feito pelo cliente (CSR) de modo a minimizar o tempo de reparo e permitir maior flexibilidade na substituição de peças com defeito. Se, durante o período de diagnóstico, a HP (ou fornecedores/parceiros de serviço da HP) concluir que o reparo pode ser efetuado pelo uso de uma peça CSR, a peça de reposição será enviada diretamente ao cliente. Existem duas categorias de peças CSR:

Obrigatória – Peças cujo reparo feito pelo cliente é obrigatório. Se desejar que a HP substitua essas peças, serão cobradas as despesas de transporte e mão-de-obra do serviço.

Opcional – Peças cujo reparo feito pelo cliente é opcional. Essas peças também são projetadas para o reparo feito pelo cliente. No entanto, se desejar que a HP as substitua, pode haver ou não a cobrança de taxa adicional, dependendo do tipo de serviço de garantia destinado ao produto.

OBSERVAÇÃO: Algumas peças da HP não são projetadas para o reparo feito pelo cliente. A fim de cumprir a garantia do cliente, a HP exige que um técnico autorizado substitua a peça. Essas peças estão identificadas com a marca "No" (Não), no catálogo de peças ilustrado.

Conforme a disponibilidade e o local geográfico, as peças CSR serão enviadas no primeiro dia útil após o pedido. Onde as condições geográficas permitirem, a entrega no mesmo dia ou em quatro horas pode ser feita mediante uma taxa adicional. Se precisar de auxílio, entre em contato com o Centro de suporte técnico da HP para que um técnico o ajude por telefone. A HP especifica nos materiais fornecidos com a peça CSR de reposição se a peça com defeito deve ser devolvida à HP. Nos casos em que isso for necessário, é preciso enviar a peça com defeito à HP dentro do período determinado, normalmente cinco (5) dias úteis. A peça com defeito deve ser enviada com a documentação correspondente no material de transporte fornecido. Caso não o faça, a HP poderá cobrar a reposição. Para as peças de reparo feito pelo cliente, a HP paga todas as despesas de transporte e de devolução da peça e determina a transportadora/serviço postal a ser utilizado.

Para obter mais informações sobre o programa de reparo feito pelo cliente da HP, entre em contato com o fornecedor de serviços local. Para o programa norte-americano, visite o site da HP (<http://www.hp.com/go/selfrepair>).

顧客自己修理保証サービス

修理時間を短縮し、故障部品の交換における高い柔軟性を確保するために、HP製品には多数の顧客自己修理（CSR）部品があります。診断の際に、CSR部品を使用すれば修理ができるとHP（HPまたはHP正規保守代理店）が判断した場合、HPはその部品を直接、お客様に発送し、お客様に交換していただきます。CSR部品には以下の2通りがあります。

- **必須** - 顧客自己修理が必須の部品。当該部品について、もしもお客様がHPに交換作業を依頼される場合には、その修理サービスに関する交通費および人件費がお客様に請求されます。
- **任意** - 顧客自己修理が任意である部品。この部品も顧客自己修理用です。当該部品について、もしもお客様がHPに交換作業を依頼される場合には、お買い上げの製品に適用される保証サービス内容の範囲内においては、別途費用を負担していただくことなく保証サービスを受けることができます。

注：HP製品の一部の部品は、顧客自己修理用ではありません。製品の保証を継続するためには、HPまたはHP正規保守代理店による交換作業が必須となります。部品カタログには、当該部品が顧客自己修理除外品である旨が記載されています。

部品供給が可能な場合、地域によっては、CSR部品を翌営業日に届くように発送します。また、地域によっては、追加費用を負担いただくことにより同日または4時間以内に届くように発送することも可能な場合があります。サポートが必要なときは、HPの修理受付窓口へ電話していただければ、技術者が電話でアドバイスします。交換用のCSR部品または同梱物には、故障部品をHPに返送する必要があるかどうかが表示されています。故障部品をHPに返送する必要がある場合は、指定期限内（通常は5営業日以内）に故障部品をHPに返送してください。故障部品を返送する場合は、届いた時の梱包箱に関連書類とともに入れてください。故障部品を返送しない場合、HPから部品費用が請求されます。顧客自己修理の際には、HPは送料および部品返送費を全額負担し、使用する宅配便会社や運送会社を指定します。

客户自行维修

HP 产品提供许多客户自行维修 (CSR) 部件，以尽可能缩短维修时间和在更换缺陷部件方面提供更大的灵活性。如果在诊断期间 HP（或 HP 服务提供商或服务合作伙伴）确定可以通过使用 CSR 部件完成维修，HP 将直接把该部件发送给您进行更换。有两类 CSR 部件：

- **强制性的** — 要求客户必须自行维修的部件。如果您请求 HP 更换这些部件，则必须为该服务支付差旅费和人工费用。
- **可选的** — 客户可以选择是否自行维修的部件。这些部件也是为客户自行维修设计的。不过，如果您要求 HP 为您更换这些部件，则根据为您的产品指定的保修服务类型，HP 可能收取或不再收取任何附加费用。

注：某些 HP 部件的设计并未考虑客户自行维修。为了满足客户保修的需要，HP 要求授权服务提供商更换相关部件。这些部件在部件图解目录中标记为“否”。

CSR 部件将在下一个工作日发运（取决于备货情况和允许的地理范围）。在允许的地理范围内，可在当天或四小时内发运，但要收取额外费用。如果需要帮助，您可以致电 HP 技术支持中心，将会有技术人员通过电话为您提供帮助。HP 会在随更换的 CSR 部件发运的材料中指明是否必须将有缺陷的部件返还给 HP。如果要求您将缺陷的部件返还给 HP，那么您必须在指定期限内（通常是五 (5) 个工作日）将缺陷部件发给 HP。有缺陷的部件必须随所提供的发运材料中的相关文件一起返还。如果未能送还缺陷的部件，HP 可能会要求您支付更换费用。客户自行维修时，HP 将承担所有相关运输和部件返回费用，并指定快递商/承运商。

有关 HP 客户自行维修计划的详细信息，请与您当地的服务提供商联系。有关北美地区的计划，请访问 HP 网站 (<http://www.hp.com/go/selfrepair>)。

客戶自行維修

HP 產品設計了許多「客戶自行維修」(CSR) 的零件以減少維修時間，並且使得更換瑕疵零件時能有更大的彈性。如果在診斷期間 HP (或 HP 服務供應商或維修夥伴) 辨認出此項維修工作可以藉由使用 CSR 零件來完成，則 HP 將直接寄送該零件給您作更換。CSR 零件分為兩種類別：

- **強制的** — 客戶自行維修所使用的零件是強制性的。如果您要求 HP 更換這些零件，HP 將會向您收取此服務所需的外出費用與勞動成本。
- **選購的** — 客戶自行維修所使用的零件是選購的。這些零件也設計用於客戶自行維修之用。不過，如果您要求 HP 為您更換，則可能需要也可能不需要負擔額外的費用，端視針對此產品指定的保固服務類型而定。

備註：某些 HP 零件沒有消費者可自行維修的設計。為符合客戶保固，HP 需要授權的服務供應商更換零件。這些零件在圖示的零件目錄中，被標示為「否」。

基於材料取得及環境允許的情況下，CSR 零件將於下一個工作日以快遞寄送。在環境的允許下當天或四小時內送達，則可能需要額外的費用。若您需要協助，可致電「HP 技術支援中心」，會有一位技術人員透過電話來協助您。不論損壞的零件是否必須退回，HP 皆會在與 CSR 替換零件一起運送的材料中註明。若要將損壞的零件退回 HP，您必須在指定的一段時間內（通常為五 (5) 個工作天），將損壞的零件寄回 HP。損壞的零件必須與寄送資料中隨附的相關技術文件一併退還。如果無法退還損壞的零件，HP 可能向您收取替換費用。針對客戶自行維修情形，HP 將負責所有運費及零件退還費用並指定使用何家快遞/貨運公司。

如需 HP 的「客戶自行維修」方案詳細資訊，請連絡您當地的服務供應商。至於北美方案，請參閱 HP 網站 (<http://www.hp.com/go/selfrepair>)。

고객 셀프 수리

HP 제품은 수리 시간을 최소화하고 결함이 있는 부품 교체 시 더욱 응통성을 발휘할 수 있도록 하기 위해 고객 셀프 수리(CSR) 부품을 다량 사용하여 설계되었습니다. 진단 기간 동안 HP(또는 HP 서비스 공급업체 또는 서비스 협력업체)에서 CSR 부품을 사용하여 수리가 가능하다고 판단되면 HP는 해당 부품을 바로 사용자에게 보내어 사용자가 교체할 수 있도록 합니다. CSR 부품에는 두 가지 종류가 있습니다.

- **고객 셀프 수리가 의무 사항인 필수 부품.** 사용자가 HP에 이 부품의 교체를 요청할 경우 이 서비스에 대한 출장비 및 작업비가 청구됩니다.
- **고객 셀프 수리가 선택 사항인 부품.** 이 부품들도 고객 셀프 수리가 가능하도록 설계되었습니다. 하지만 사용자가 HP에 이 부품의 교체를 요청할 경우 사용자가 구입한 제품에 해당하는 보증 서비스 유형에 따라 추가 비용 없이 교체가 가능할 수 있습니다.

참고: 일부 HP 부품은 고객 셀프 수리가 불가능하도록 설계되었습니다. HP는 만족스러운 고객 보증을 위해 공인 서비스 제공업체를 통해 부품을 교체하도록 하고 있습니다. 이러한 부품들은 Illustrated Parts Catalog에 "No"라고 표시되어 있습니다.

CSR 부품은 재고 상태와 지리적 조건이 허용하는 경우 다음 영업일 납품이 가능하도록 배송이 이루어집니다. 지리적 조건이 허용하는 경우 추가 비용이 청구되는 조건으로 당일 또는 4시간 배송이 가능할 수도 있습니다. 도움이 필요하시면 HP 기술 지원 센터로 전화하십시오. 전문 기술자가 전화로 도움을 줄 것입니다. HP는 결함이 발생한 부품을 HP로 반환해야 하는지 여부를 CSR 교체 부품과 함께 배송된 자료에 지정합니다. 결함이 발생한 부품을 HP로 반환해야 하는 경우에는 지정된 기간 내(통상 영업일 기준 5일)에 HP로 반환해야 합니다. 이 때 결함이 발생한 부품은 제공된 포장 재료에 넣어 관련 설명서와 함께 반환해야 합니다. 결함이 발생한 부품을 반환하지 않는 경우 HP가 교체 부품에 대해 비용을 청구할 수 있습니다. 고객 셀프 수리의 경우, HP는 모든 운송 및 부품 반환 비용을 부담하며 이용할 운송업체 및 택배 서비스를 결정합니다.

HP 고객 셀프 수리 프로그램에 대한 자세한 내용은 가까운 서비스 제공업체에 문의하십시오. 북미 지역의 프로그램에 대해서는 HP 웹 사이트(<http://www.hp.com/go/selfrepair>)를 참조하십시오.

Acronyms and abbreviations

ABEND

abnormal end

ACU

Array Configuration Utility

AMP

Advanced Memory Protection

ASR

Automatic Server Recovery

BBWC

battery-backed write cache

CSR

Customer Self Repair

ESD

electrostatic discharge

FBWC

flash-backed write cache

HP SIM

HP Systems Insight Manager

HP SUM

HP Smart Update Manager

IEC

International Electrotechnical Commission

iLO

Integrated Lights-Out

iLO 3

Integrated Lights-Out 3

IML

Integrated Management Log

KVM

keyboard, video, and mouse

NMI

non-maskable interrupt

NVRAM

non-volatile memory

ORCA

Option ROM Configuration for Arrays

PCIe

peripheral component interconnect express

PCI-X

peripheral component interconnect extended

PDU

power distribution unit

POST

Power-On Self Test

PSP

ProLiant Support Pack

RBSU

ROM-Based Setup Utility

RDIMM

Registered Dual In-line Memory Module

RDP

Rapid Deployment Pack

SAN

storage area network

SAS

serial attached SCSI

SATA

serial ATA

SD

Secure Digital

SFF

small form-factor

TMRA

recommended ambient operating temperature

TPM

trusted platform module

UDIMM

Unregistered Dual In-Line Memory Module

UID

unit identification

VCA

Version Control Agent

VCRM

Version Control Repository Manager

Index

1

10Gb sideband connector 11

A

AC power supply 111, 112, 113
access panel 21
acoustics statement for Germany 108
ACU (Array Configuration Utility) 78
additional information 86
Advanced ECC memory 41, 42, 76, 77
air baffle 22
airflow requirements 27
AMP (Advanced Memory Protection) 76
AMP modes 76
Array Configuration Utility (ACU) 78
ASR (Automatic Server Recovery) 79
authorized reseller 115
authorized technician 87
auto-configuration process 75
Automatic Server Recovery (ASR) 79

B

Basic Input/Output System (BIOS) 76, 80, 91
battery 11, 21, 58, 102, 107
battery pack, removing 21
BBWC (battery-backed write cache) 21, 58
BBWC cabling 71
beep codes 101
BIOS (Basic Input/Output System) 76, 80, 91
BIOS Serial Console 76
BIOS upgrade 80
boot options 76
BSMI notice 106
buttons 7, 8, 10

C

cables 70, 89, 104
cables, troubleshooting 89
cabling 30, 70
cabling, battery pack 71
cabling, BBWC 71

cache module battery pack 58
cache module connector 11
cache module installation 57
Canadian notice 105
Care Pack 26, 85
cautions 87
cautions, electrical 87
cautions, power cord 87
cautions, ventilation 87
Change Control 85
Chinese notice 107
compliance 103
components 7, 9
configuration of system 31, 74
configuration tools 74
configuring AMP modes 76, 77
configuring memory 77
connection problems 89
connectors 7, 9, 11
contacting HP 115
controller 56

D

DC power specifications 113
DC power supply 113
Declaration of Conformity 104
default settings 41
diagnosing problems 86
diagnostic tools 79, 80, 81
diagnostics utility 81
DIMM installation guidelines 42
DIMM slot locations 12
DIMM slots 11, 42
DIMMs 39, 77
DIMMs, installation 46
DIMMs, single- and dual-rank 39
disposal, waste 106
downloading files 115
drivers 83
dual bezel blank 48
DVD tray 7, 49
DVD-ROM cabling 72
DVD-ROM drive 47, 49, 72
DVD-ROM drive connectors 11

E

- electrical grounding requirements 28
- electrostatic discharge 109
- environmental requirements 27, 110
- Erase Utility 80
- error messages 101
- European Union notice 105
- European Union regulatory notice 105
- expansion boards 59
- extending server from rack 19

F

- fan connectors 11
- fan LED 13
- fan module connector 11
- fan module locations 16
- fans 33
- FBWC cabling 71
- FCC (Federal Communications Commission)
 - notice 103, 104
- FCC rating label 103
- features 7
- Federal Communications Commission (FCC)
 - notice 103, 104
- firmware upgrade utility, troubleshooting 86
- flowcharts 90, 91, 93, 96, 97, 99
- front panel buttons 8
- front panel components 7
- front panel LEDs 8

G

- general diagnosis flowchart 91
- graphics card cabling 73
- graphics card option 61, 73
- grounding methods 109
- grounding requirements 28

H

- hard drive backplane 52
- hard drive backplane cabling 70
- hard drive bays 7
- hard drive bezel blanks 47
- hard drive blanks 47
- hard drive data connector 11
- hard drive LEDs 16
- hard drive power connector 11
- hard drives 7, 15, 16, 47
- hard drives, determining status of 16

- hard drives, installing 49
- hard drives, removing 48
- hardware options 33
- hardware options installation 29, 33
- health driver 79
- health LEDs 8, 16
- help resources 115
- hot-plug power supply calculations 114
- HP contact information 115
- HP Enterprise Configurator 114
- HP Insight Diagnostics 81, 82
- HP Insight Diagnostics survey functionality 82
- HP Insight Remote Support software 83
- HP Smart Update Manager overview 84
- HP website 115

I

- identification number 103
- identifying components 7
- iLO (Integrated Lights-Out) 80
- IML (Integrated Management Log) 82
- Important Safety Information document 86
- Insight Diagnostics 81, 82, 83
- installation services 26
- installation, server options 29, 33
- installing hardware 33
- installing server 30
- installing server options 29, 33
- Integrated Lights-Out (iLO) 80
- Integrated Management Log (IML) 82
- internal cables 70
- internal health LED 16
- internal USB connector 11

J

- Japanese notice 106

K

- Korean notices 107

L

- laser devices 107
- LEDs 7, 14
- LEDs, hard drive 16
- LEDs, troubleshooting 86
- LEDs, unit identification (UID) 8, 10
- lockstep memory 41, 43, 77
- loose connections 89

M

- maintenance guidelines 83
- management tools 79
- memory 38, 39, 41, 77
- memory configurations 40, 41
- memory slot LEDs 13
- memory subsystem architecture 38
- memory, Advanced ECC 76, 77
- memory, configuration requirements 40, 43
- memory, configuring 40, 41, 42, 77
- memory, lockstep 41, 43, 77
- memory, mirrored 42, 45, 76, 78
- memory, online spare 41, 44, 76, 77
- memory, RAID 76
- mirrored memory 42, 45, 76, 77, 78
- multi-processor Advanced ECC population order 43

N

- NIC connectors 9
- NMI jumper 11, 13

O

- online spare memory 41, 44, 76
- online spare population guidelines 44
- online spare population order, multi-processor 44
- online spare population order, single-processor 44
- operating systems 32, 84
- optimum environment 27
- Option ROM Configuration for Arrays (ORCA) 78
- options installation 29, 33
- ORCA (Option ROM Configuration for Arrays) 78
- OS boot problems flowchart 97
- overtemperature LED 13

P

- PCI power connector 11
- PCI riser board assembly 23, 24
- PCI riser board expansion slot definitions 9
- PCIe riser board connector 11
- PCI-X boards 60
- PDU (power distribution unit) 28
- phone numbers 115
- population guidelines, online spare 44
- POST error messages 101
- POST problems flowchart 96
- power button cable connector 11
- power button cabling 72
- power button connector 11

- power calculator 114
- power cord 87, 108
- power distribution unit (PDU) 28
- power LEDs, system 8
- Power On/Standby button 8, 19, 31
- power requirements 114
- power supplies 63, 110, 111, 112, 113, 114
- power supplies, removing 63
- power supply 63, 114
- power supply bays 9
- power supply connector 11
- power supply LEDs 13
- power supply output 114
- power supply specifications 110, 111, 112, 113
- powering down 19
- powering up 19, 75
- power-on problems flowchart 93
- pre-diagnostic steps 86
- preparation procedures 19, 89
- preparing the server for diagnosis 89
- problem diagnosis 86
- processor socket 11
- processors 11, 33
- ProLiant Support Pack (PSP) 84
- PSP (ProLiant Support Pack) 84
- PSPs, overview 84

R

- rack installation 26, 29, 30
- rack mounting hardware 29
- rack resources 26
- rack stability 87
- rack warnings 29, 87
- RAID memory 76
- RBSU (ROM-Based Setup Utility) 74, 76
- RBSU configuration 75
- RDIMM configuration 41
- rear panel buttons 9, 10
- rear panel components 9
- rear panel LEDs 10
- recommended ambient operating temperature (TMRA) 27
- recovery key 68
- redundant power supply configurations 63
- redundant ROM 81
- registering the server 32
- regulatory compliance notices 103, 106
- remote support and analysis tools 83
- required information 115
- requirements, airflow 27

- requirements, electrical grounding 28
- requirements, environmental 27, 110
- requirements, power 28, 114
- requirements, site 27
- requirements, space 27
- requirements, temperature 27
- ROM redundancy 81
- ROM-Based Setup Utility (RBSU) 68, 74
- ROMPaq utility 80, 81

S

- safety considerations 29, 86
- safety information 81
- SAN configuration 78
- SATA DVD drive connector 11
- scripted installation 74
- SD card slot 11
- serial connector 9
- serial number 79
- series number 103
- server fault indications flowchart 99
- server features and options 33
- server options, installing 29, 33
- server specifications 110, 114
- service notifications 90
- shipping carton contents 29
- single-processor Advanced ECC population order 42
- site requirements 27
- Smart Update Manager 84
- SmartStart autorun menu 74
- SmartStart Scripting Toolkit 74
- SmartStart, overview 74
- space requirements 27
- specifications 110, 111, 112, 113
- specifications, DC power supply 113
- specifications, power 110, 111, 112, 113
- specifications, server 110, 114
- standards 103
- start diagnosis flowchart 90
- static electricity 109
- support 83, 115
- support packs 74
- supported operating systems 84
- supported targets 86
- symbols on equipment 87
- symptom information 88
- system battery 11, 102
- system board battery 11, 107
- system board components 11

- system components 7
- system configuration settings 74
- System Erase Utility 80
- system maintenance switch 11, 12
- system power LED 8
- system, keeping current 83
- Systems Insight Display cabling 72
- Systems Insight Display LEDs 13, 14
- Systems Insight Display, ejecting 20

T

- T-10/T-15 Torx screwdriver 18
- Taiwan battery recycling notice 108
- technical support 115
- telephone numbers 115
- temperature requirements 27
- temperature, overtemperature LED 13
- TMRA (recommended ambient operating temperature) 27
- tools 18
- TPM (Trusted Platform Module) 66, 67, 68
- TPM connector 11
- troubleshooting 86
- troubleshooting flowcharts 90
- troubleshooting resources 86
- troubleshooting, firmware upgrade utility 86
- Trusted Platform Module (TPM) 66, 67, 68

U

- UDIMM configuration 41
- UID button 10
- UID LED 10, 19
- updating the system ROM 81
- USB (universal serial bus) 11
- USB connectors 7, 9, 11
- USB support 81
- utilities 74
- utilities, deployment 74

V

- ventilation 27
- Version Control Agent (VCA) 84
- Version Control Repository Manager (VCRM) 84
- video connector 7, 9

W

- warnings 29, 87
- website, HP 115