



Installation and Assembly:

Adapter Plate for DLA-RS40, DLA-RS50, DLA-RS60, DLA-RS45, DLA-RS55, DLA-RS65, DLA-RS46, DLA-RS48, DLA-RS4810, DLA-RS56, DLA-RS66, DLA-RS49, DLA-RS4910, DLA-RS57, DLA-RS67, DLA-RS6710, DLA-RS400, DLA-RS500, DLA-RS600, DLA-X3, DLA-X7, DLA-X9, DLA-X30, DLA-X70, DLA-X90, DLA-X35, DLA-X55, DLA-X75, DLA-X95, DLA-X500, DLA-X700, DLA-X900, DLA-X550, DLA-X750, DLA-X950 Projectors

Model: PAP-JVC-DLA

Max Load Capacity: 50 lb (22.6 kg)

Parts List

Description	Qty.	Part #
A adapter plate	1	055-1994
B M5 x 30 mm socket pin serrated washer head screw	4	510-1112
C 6.5 ID x 17.8 OD x 1.6 flat washer	4	540-1078
D 4 mm allen wrench	1	560-9646

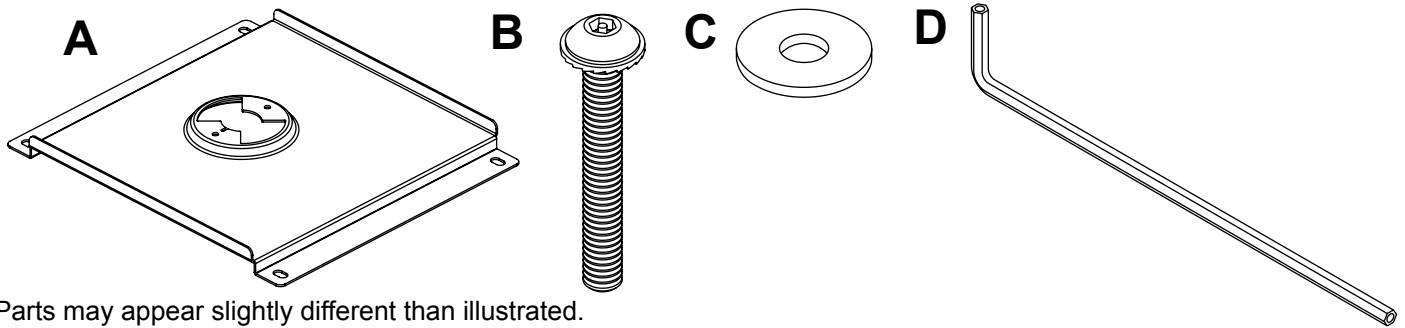

Parts may appear slightly different than illustrated.

⚠ WARNING

- Installer must verify that the supporting surface will safely support the combined weight of all attached equipment and hardware.

- 1 Attach adapter plate (A) to projector using four M5 x 30mm socket pin serrated washer head screws (B), and four 6.5 ID x 17.8 OD x 1.6 flat washers (C) using 4mm allen wrench (D).

*Notch indicates front of projector.

