



# DVR RECEIVERS USER GUIDE

DIRECTV PLUS® HD DVR  
DIRECTV PLUS® DVR



Your receiver is ENERGY STAR qualified, giving you the benefit of saving energy and helping our environment (This may not apply to older models).

When used in conjunction with a DIRECTV subscription, this receiver meets ENERGY STAR criteria without requiring the consumer to take any additional steps.

Welcome! Now that you're plugged in, it's time to start enjoying access to over 285 channels of TV programming, including satellite music channels and an extensive Pay Per View selection. We'll take you step by step through everything from pushing the POWER button to recording your favorite programs. **If you want a quick overview of your system, read Chapter 1, Quick Start.** Detailed information starts in Chapter 2. This user guide applies to the DIRECTV Plus® HD DVR (Digital Video Recorder) and DIRECTV Plus® DVR. Because this user guide was designed to accommodate several models of DIRECTV® Receivers, your receiver and its user interface may vary slightly from what is shown here.

## Getting Connected

If a professional installed your DIRECTV® Receiver, you're ready to start watching TV. If your receiver was not professionally installed or you just added a surround sound system or other equipment, please see Chapter 3: Connections for TV and Auxiliary Equipment.

### IMPORTANT:

- You must subscribe to DIRECTV DVR service in order to use the recording features.
- You must subscribe to HD Access in order to be able to view the HD channels included in your programming package.
- You must subscribe to the DIRECTV® Whole-Home DVR service in order use to the DIRECTV® Whole-Home DVR service viewing features.
- DIRECTV hardware, programming, DVR service and HD Access fee available separately.

For information and pricing please visit [directv.com](http://directv.com).

# TABLE OF CONTENTS

● Welcome to the DIRECTV Family .....	3
● Product Information .....	8
● Notes .....	9
● Safety & Care .....	10

## CHAPTER 1: QUICK START

---

● Using Your Remote Control.....	14
Turning Equipment On and Off .....	14
Navigation and Destination Buttons .....	15
Shortcut Buttons .....	15
DVR Control Buttons .....	16
The Progress Bar .....	17
● Viewing Live Television.....	18
Program Guide .....	18
Local Channels .....	18
Unsubscribed Channels .....	18
HD & SD Channels .....	19
3D .....	19
Guide Banners .....	20

Mini Guide .....	20
Interactive Channels .....	21
Channel Banners .....	23
Main Menu .....	23
DIRECTVCinema® and Pay Per View Events .....	24

● Recording Programs .....	25
Recording a Single Show .....	25
Recording an Entire Series .....	27
Watching and Deleting your Recorded Shows .....	28

## CHAPTER 2: DETAILED INFORMATION

---

● Program Guide Features and Options .....	30
Filtering the Guide .....	30
Guide Options .....	31
● Live TV Features and Options .....	32
Live TV Options .....	32
Live Buffer .....	34
DoublePlay™ .....	35
QuickTune .....	36
GameSearch™ .....	36

● <b>Recorded TV Special Features</b> .....	<b>37</b>	● <b>Smart Search™ (HD DVR Receivers)</b> .....	<b>57</b>
Bookmarks .....	37	Suggested Searches .....	57
Recording from a Computer or Phone.....	38	Search Results .....	58
● <b>Main Menu - Overview</b> .....	<b>40</b>	Movie or Show .....	58
● <b>My Playlist</b> .....	<b>43</b>	Person .....	59
My Playlist .....	43	Channel .....	60
Playlist Options .....	44	Category .....	61
Managing My Playlist .....	45	Keyword .....	62
DIRECTV® Whole-Home DVR Service .....	47	Recent Searches .....	64
● <b>DIRECTV on DEMAND</b> .....	<b>52</b>	● <b>Search for Shows (SD DVR Receivers)</b> .....	<b>65</b>
Finding On DEMAND Shows .....	52	Search by Title .....	65
Channels On Demand .....	53	Search by Person .....	66
DIRECTV Cinema™ on Demand .....	54	Search by Channel .....	67
Showcases .....	54	Search by Keyword .....	68
Downloading On Demand Shows .....	55	Recent Searches .....	68
Checking the Download Queue .....	55	● <b>Manage Recordings</b> .....	<b>69</b>
Pausing Your Downloads .....	56	To Do List .....	69
Playing Your Downloaded Shows .....	56	Queue .....	70
		History .....	70

# TABLE OF CONTENTS

Purchases .....	70
Series Manager (Prioritizer) .....	71
Manual Recording .....	72
Recording Defaults .....	73
● <b>Music, Photos &amp; More</b> .....	<b>74</b>
● <b>Caller ID</b> .....	<b>77</b>
● <b>TVmail</b> .....	<b>78</b>
● <b>Parental, Fav's &amp; Setup</b> .....	<b>79</b>
Parental Controls .....	79
Favorite Channels .....	85
System Setup .....	86
Help Topics and FAQs .....	98

## CHAPTER 3: CONNECTIONS FOR TV AND AUXILIARY EQUIPMENT

---

● <b>Connections</b> .....	<b>100</b>
Your Phone Connection .....	100
Connections for Auxiliary Equipment.....	100
● <b>Setup and Activation</b> .....	<b>104</b>
Guided Setup .....	104
Activate Your DIRECTV® Service .....	104

## CHAPTER 4: TROUBLESHOOTING

---

● <b>Troubleshooting Tips</b> .....	<b>106</b>
Resetting/Reauthorizing Your Receiver .....	106
System Software Updates .....	106
On-Screen Error Messages .....	107
● <b>DIRECTV Receiver or TV Problems</b> .....	<b>108</b>
● <b>Recorded TV Troubleshooting</b> .....	<b>116</b>
● <b>Remote Control Problems</b> .....	<b>120</b>
● <b>Running the System Test</b> .....	<b>121</b>

## CHAPTER 5: WARRANTY & OTHER INFORMATION

---

- Limited 90-Day Warranty ..... 124
- DIRECTV Protection Plan ..... 127
- FCC Customer Information ..... 129
- Terms & Conditions for Use of Software ..... 133

## APPENDICES

---

- Appendix 1: Receivers Front and Back Panels ..... 146
- Appendix 2: How to Network Your DVR ..... 154
- Appendix 3: About High-Definition ..... 162
- Index ..... 168

## Product Information

Keep your receipt to obtain warranty parts and service and for proof of acquisition. Attach it here and record the serial and model numbers in case you need them. These numbers are typically behind the card door on the front panel of your receiver.\*

Model No. *	
Serial No.	
Acquisition Date	
Dealer/Address/Phone	
Access Card *	
Receiver ID *	





Your DIRECTV® Receiver has been designed and manufactured to stringent quality and safety standards. You should, however, be aware of the following important precautions for safe and optimal use of the equipment.

Meaning of symbols printed on the rear panel of the product:



This symbol indicates that dangerous voltage consisting a risk of electric shock is present within this unit.



This symbol indicates that there are important operating and maintenance instructions in the literature accompanying this unit.

## Important Safety Instructions

- 1) Read these instructions.
- 2) Keep these instructions.
- 3) Heed all warnings.
- 4) Follow all instructions.
- 5) Do not use this apparatus near water.
- 6) Clean only with dry cloth.
- 7) Do not block any ventilation openings. Install in accordance with the manufacturer's instructions.
- 8) Do not install near any heat sources such as radiators, heat registers, stoves, or other apparatus (including amplifiers) that produce heat.
- 9) Do not defeat the safety purpose of the polarized or grounding-type plug. A polarized plug has two blades with one wider than the other. A grounding type plug has two blades and a third grounding prong. The wide blade or the third prong are provided for your safety. If the provided plug does not fit into your outlet, consult an electrician for replacement of the obsolete outlet.
- 10) Protect the power cord from being walked on or pinched particularly at plugs, convenience receptacles, and the point where they exit from the apparatus.
- 11) Only use attachments/accessories specified by the manufacturer.
- 12) Use only with the cart, stand, tripod, bracket, or table specified by the manufacturer, or sold with the apparatus. When a cart is used, use caution when moving the cart/apparatus combination to avoid injury from tip-over.
- 13) Unplug this apparatus during lightning storms or when unused for long periods of time.
- 14) Refer all servicing to qualified service personnel. Servicing is required when the apparatus has been damaged in any way, such as power-supply cord or plug is damaged, liquid has been spilled or objects have fallen into the apparatus, the apparatus has been exposed to rain or moisture, does not operate normally, or has been dropped.



**WARNING:** To reduce the risk of fire or electric shock, do not expose this product to rain or moisture. The apparatus shall not be exposed to dripping or splashing and no objects filled with liquids, such as vases, shall be placed on the apparatus.

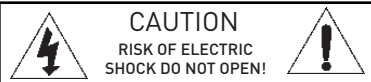

**CAUTION:** To reduce the risk of electric shock, do not remove cover (or back). No user-serviceable parts inside. Refer servicing to qualified service personnel.

**IMPORTANT:** Be sure not to place your DIRECTV® Receiver near anything WET or HOT!  
If this product is rated at 240VAC, a suitable attachment plug should be used.

**CAUTION:** Avoid moisture to reduce the risk of fire or electric shock. The DIRECTV® Receiver should not be used near water (for example, kitchen sink, bathtub, pool, damp basement). Also, never spill liquid on the receiver, and do not place vases or other vessels containing liquid on top of it.

**TIP:** We highly recommend plugging the DIRECTV® Receiver into a surge protector to prevent damage from fluctuations in your power supply.

- Ensure proper ventilation — the vent slots on the DIRECTV® Receiver must be left uncovered to allow proper airflow to the unit. Blocking the airflow to the unit could impair performance or damage your receiver and other components.
  - Do not stack electronic components or other objects on top of the DIRECTV® Receiver. Also, do not stack the receiver on top of a “hot component” such as an audio power amplifier.
  - Protect your components from power surges by connecting all the components before plugging any power cords into the wall outlet. Use of a surge protector is also recommended.
  - Don’t overload power outlets or extension cords, which can result in the risk of fire or shock. It’s also important to use only the type of power source indicated on the marking label or in this manual.
  - Avoid audio hum or interference by inserting all cable plugs firmly into their jacks. Also, place Audio/Video (A/V) cables to the sides of the TV back panel rather than down the middle once connected. Try not to coil any twin-lead cables and keep them away from A/V cables as much as possible.
  - Never insert objects of any kind into any openings in the DIRECTV® Receiver (other than the DIRECTV® Access Card as detailed in this manual).
  - Place it on a flat, hard surface — do not operate the DIRECTV® Receiver on a carpet or other padded surface.
  - Always unplug your DIRECTV® Receiver before moving it.
  - Always unplug the DIRECTV® Receiver, TV and other equipment before you connect or disconnect any cables.
  - The only way to disconnect the DIRECTV® Receiver from the power supply is to remove the power cord. The DIRECTV® Receiver unit must therefore be installed next to the power point which must be easily accessible.
  - **CAUTION:** Electric Shock — never attempt to disassemble the DIRECTV® Receiver yourself; always take it to a qualified service person when repair is required. Opening or removing covers may expose dangerous voltage or other risks, and incorrect reassembly can cause shock when receiver is subsequently used. Attempted self-repair may also void your warranty. Changes or modifications not expressly approved by the party responsible for compliance (by the warranty or by the manufacturer) could void the user’s authority to operate the equipment.
  - Do not drop your DIRECTV® Receiver and always move it with care.
  - Have your DIRECTV® Receiver professionally serviced (do not attempt to service it yourself).
  - Any changes or modifications in construction of this device which are not expressly approved by the party responsible for compliance could void the user’s authority to operate the equipment.
  - If you move your DIRECTV® Receiver between locations at different temperatures, allow it to reach room temperature before you apply power to it.
  - Do not pick up or otherwise move your DIRECTV® Receiver while it is connected to the AC power supply. If you want to move your set-top box, first disconnect it, then wait at least 30 seconds before continuing
  - **CAUTION:** To reduce the risk of fire, use only No. 26 AWG or better telecommunications line cord.
  - **CAUTION:** Replace remote control batteries with same or equivalent type. There is danger of explosion if batteries are incorrectly replaced.
  - For your information: The identification sticker can be located behind the small door on the front panel of your receiver. The telecommunication network voltage used is the category number 3.
- Note to Satellite Dish Installer:** This reminder is provided to call your attention to articles 810 and 820 of the 2005 National Electrical Code. Refer to article 810, in particular 810-1 and 810-15, for required grounding of the metal structure of the dish antenna. Refer also to the 810-2 which, by reference to article 820, requires that the satellite dish coaxial cable shield be connected to the grounding system of the building as close to the point of cable entry as practical.



## CHAPTER 1 - QUICK START

---

- USING YOUR REMOTE CONTROL .....14
- VIEWING LIVE TELEVISION .....18
- RECORDING PROGRAMS.....25

# Using Your Remote Control

This universal remote control is your touch point to the system, so we'll start here.

## Turning Equipment On and Off



**Note:** Each time you press a button, a green light at the top of the remote flashes. If the light flashes several times for just one press, it means the batteries (size AA) are getting low and need to be replaced.

These two buttons turn your TV and DIRECTV® Receiver on or off together. If your DIRECTV® System was installed professionally, your remote has already been programmed to operate your TV. If you need to reprogram the remote for a new TV or for any other reason, press MENU, select Parental, Fav's & Setup, then System Setup, then Remote Control, and follow the step by step instructions.

Mode Switch



Use the POWER (PWR) button and Mode Switch to turn a single component on or off (for example a DVD player or surround sound system). Simply slide the mode switch to the position that matches the component you want to control and then use the POWER button to turn it off or on. **The mode switch must always be in the left-most position to control your DIRECTV® Receiver.** If the mode switch is in a position that has not been programmed, or if you press a button that is not supported by that particular piece of equipment, an on-screen message will pop up to alert you.

## Navigation and Destination Buttons



The buttons in the middle of the remote are navigation and destination keys.

Press the **GUIDE** button to go to the program guide screen. Press the **ACTIVE** button to go to the DIRECTV Interactive services home page. The **LIST** button takes you to the Playlist. See Chapter 2, “My Playlist” for details. Press **EXIT** to get out of any menu screen and return to live TV. Use the **ARROW** buttons and **SELECT** button to navigate through the guide or any menu screen. Press **BACK** to move back to the previous screen. (You can also use the **LEFT ARROW** button to step backward one column at a time.) The **MENU** button takes you to the main menu where you go to access all of the features available in your system. Press **INFO** on any show to see information about that show.

## Shortcut Buttons



You can move through all of the DIRECTV user screens using only the direction **ARROW** buttons and the **SELECT** button as appropriate. However, the **RED, GREEN, YELLOW, and BLUE buttons on the remote are special shortcuts** that change function depending on which menu screen you are looking at. As you use the system look in the bottom right of particular screens for hints that tell you which color button to use for a particular shortcut. You’ll see several examples in this chapter.



Shortcut hints



## DVR Control Buttons



These are the DVR control buttons (Rewind, Fast Forward, etc.). They can also be used along with the mode switch to control a DVD player or other auxiliary equipment.



### PLAY / SLOW MOTION

Starts the recorded video or paused live TV currently on screen. Hold this button down for slow motion.



### PAUSE / FRAME BY FRAME

Freezes the action of any live or prerecorded television program. While paused, press FFWD or REW to move forward or backward frame by frame.



### FFWD / JUMP TO TICKMARK

Fast-forwards recorded or live-stored video. Press up to four times to fast-forward at increasing speeds. Press ADVANCE while fast-forwarding to go to the next 15-minute tickmark.\* Pressing PLAY returns to normal play.



### REW / JUMP TO TICKMARK

Rewinds recorded or live-stored video. Press up to four times to rewind at increasing speeds. Press REPLAY while rewinding to go to the previous 15-minute tickmark.\* (Pressing play returns to normal play.)



### RECORD

One press allows you to record programs in the Guide and live TV. Press twice to record a series.



### STOP

While watching recorded TV, pressing this stops playback, displays the recorded program info screen and inserts live TV in the top right.



### REPLAY / JUMP TO BEGINNING OF PROGRAM

Jumps the program you're watching backwards 6 seconds and starts playing from that point. Holding down REPLAY jumps to the beginning of the program.



### ADVANCE / JUMP TO END OF PROGRAM

Jumps ahead in recorded or live-stored video by 30 seconds. Press multiple times to skip multiples of 30 seconds. Hold down to continue to the end of the program.

*\*Some Standard-Definition DVRs (models R15/R16) work differently. If you have one of these receivers, press and hold the REW or FFWD buttons to skip to the previous or next tickmark.*



## The Progress Bar

When you use the DVR control buttons, this indicator bar appears at the bottom of the screen to show where you are in the program and how far you can go forward or back. For live programs, the progress bar is green and the time shown is the time of day.

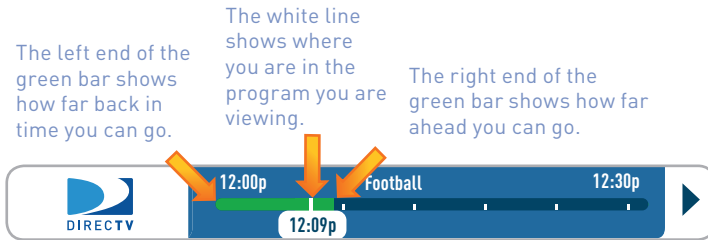

If you press the RECORD button during a live show, the progress bar turns orange and the orange record icon appears next to the title of the show.

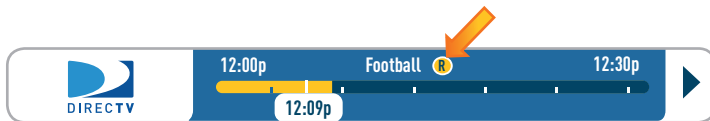

# Viewing Live Television

## Program Guide

To see what's showing, press the GUIDE button to display the on-screen program guide. The guide holds up to 14 days of programming information for you. You can navigate in the guide three ways: use the ARROW buttons to move one cell at a time up/down/left/right; use the CHAN/PAGE button to scroll a whole page up or down; type in the channel number to go directly there. Look for the color-button hints at the bottom of the screen for shortcuts (use the GREEN button to move ahead in time 12 hours, once there use the RED button to come back 12 hours). If you press GUIDE twice, you'll see a screen that lets you filter the guide. See Chapter 2 "Program Guide Features and Options, Filtering the Guide" for details.

## Local Channels

Your DIRECTV-provided local channels can be found in the guide from channel numbers 2 through 69.

## Unsubscribed Channels

Channels in the guide that are not part of your subscription package are shown grayed out. You can customize your guide to hide those channels. See Chapter 2 "Program Guide Features and Options", "Guide Options" for details.



Look for shortcut hints here.

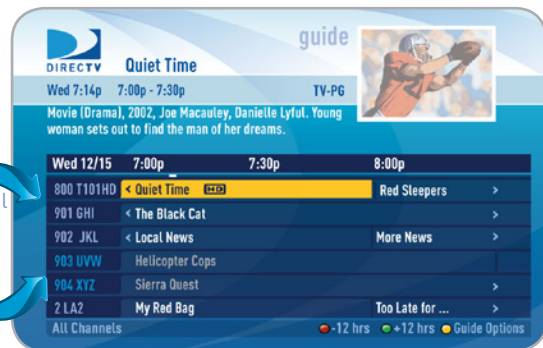

HD Channel

Unsubscribed Channels

## HD and SD Channels

DIRECTV has a tremendous offering of HD channels and they are spread throughout the guide. To find them, look for HD after the channel call sign (i.e. STZHD or CNNHD) in the channel column of the guide and also look for HD after the program title in the guide. If you want to see only the HD version of a channel in the guide go to Chapter 2, "Parental, Fav's & Setup", "System Setup, Display" for instructions on how to make that setting.

## 3D Channels

### High-Definition Receivers

Just like the 3D experience in movie theatres, DIRECTV 3D make you feel like you could reach out and touch whatever you're watching. Just hook up your 3D HDTV, put on your 3D glasses and watch the best in entertainment virtually jump into your home.

3D channels are in the 100's series in the Guide, starting on channel 103. For a list of 3D programs, press GUIDE, press the YELLOW button and then select "Sort programs by category". Select "3D" and a list of 3D programs will display.



**Note:** There is no separate 3D fee but DIRECTV 3D programming is broadcast in HD and requires HD Access, HD receiver (HR21, H21 or later), compatible 3D HDTV and 3D glasses. CHOICE(TM) package or higher required for ESPN 3D. For more information, visit [directv.com/3D](http://directv.com/3D)

## Mini-guide

If you are watching a show and want a quick look at what's on next, **press the BLUE button to display a one-line mini program guide**. You can use it for the current channel or you can type in a new channel number to see what's on there. Press SELECT on the new show if you want to go to that channel.

One-line  
mini-guide



## Interactive Channels

Interactive channels are unique. In addition to video and audio, they also contain a software application that lets you interact with what you see on screen. When accessing these channels you will have to wait a few seconds for the software to download.

- Press the ACTIVE button on your remote to get the latest weather, horoscopes, lottery results and more. The channel is ready to interact when the yellow highlight box appears.
- To exit an interactive channel, press GUIDE and pick the channel you want to move to or you can type in the new channel number while in the interactive channel.
- To find other interactive channels, take a look at the program guide from channels 100 to 115. The News Mix and Sports Mix channels let customers with a qualifying programming package see up to eight of the hottest channels on one screen. Move the yellow highlight box around using the direction arrows on your remote to hear the audio associated with each channel. If you want to see one of the channels full-screen, move the yellow highlight box over it and press SELECT.



## Viewing Live Television

- The GSN Game Lounge™ service contains memory and skill games that you can play on-screen using only your remote. There are free as well as subscription-only games. If you become a top scoring player you will see your name on the leader board.



- Interactive content, like scores, statistics and other information, is also provided along with some of our special sports and entertainment channels. Look for an on-screen popup that lets you know when interactive content is available and follow the on-screen instructions to use the interactive features.

MINIMIZE		WIMBLEDON	
NFL	1 S. Williams	7	13
NBA	7 Ivanovic	6	11
MLB AL	Watch Now		
MLB NL	2 Safina	6	7 3
NHL	13 Bartoli	2	5 2
NCAA FB	Watch Now		
NCAA BB	3 Dementieva	6	4 0
TENNIS M	5 V. Williams	4	6 0
TENNIS W	Watch Now		
GOLF	4 Jankovic	6	5
	10 Petrova	1	4
	Watch Now		
	CLEAR	1/1	

## Channel Banner

When you find a current show in the guide that you want to watch, press SELECT and the receiver will tune to that channel. A channel banner will briefly display at the top of the screen, showing you the program name, channel number, date, time and other information. **You can display the channel banner at any time by pressing the INFO button.** The icons near the upper right give you more information about your show or your system such as whether a second audio language is available or if you have a system message waiting. If your program has an alternate audio track, press the GREEN button to hear it. Go to the inside of the back cover of this manual to get an explanation of all the icons.



## Main Menu

Use the main menu to access key system features such as, My Playlist, Smart Search, Parental Controls, System Setup, Manage Recordings and more. Press MENU on your remote to display the menu. Press MENU again (or EXIT) to make it go away.

**Note:** The menu options may be slightly different on a Standard-Definition DVR than on an HD DVR. These differences are described in Chapter 2.



## DIRECTV Cinema™ and Pay Per View Events

You don't have to go out for the best and biggest movies and special events! Recent hits and events like sports, comedy and more are available 24 hours a day on DIRECTV Cinema™ on Demand, channel 1100. You'll also find them listed in the program guide starting around channel 120.

To buy a program, tune to it directly or press INFO on the highlighted program in the guide. Select the Record option and follow the on-screen instructions. As long as your receiver is connected to a land-based phone line, you can use your remote to order.

You can cancel your Pay Per View order for any reason as long as none of the program has been watched. Your receiver will let you record Pay Per View programs before you buy them; you will only be charged if you watch them. If the program has already been recorded, press LIST, highlight the show and press the RED button to delete it. If the program is set to record in the future, press MENU, then select "Manage Recordings" then "To Do List." Highlight the program and press the RED button to cancel it.

**Note:** You can also order your DIRECTV Cinema movies and Pay Per View events on the Internet at [directv.com](http://directv.com).

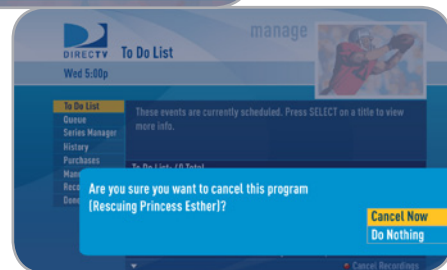
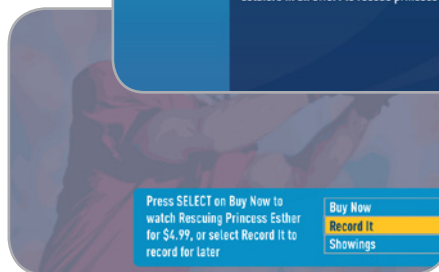



## Recording a Single Show

### From Live TV

To record a show you are currently watching, simply press RECORD once. The progress bar will appear and turn orange and the circle R icon will appear next to the title to let you know your show is now being recorded.



### From the Guide

You don't have to be watching a show to record it. Simply find it in the program guide and use the RECORD button as described above. The orange record icon appears to let you know that your show is being recorded or is scheduled to record.

**Note:** You can record two shows at the same time with your DIRECTV DVR if you have made the proper connections to your satellite dish.

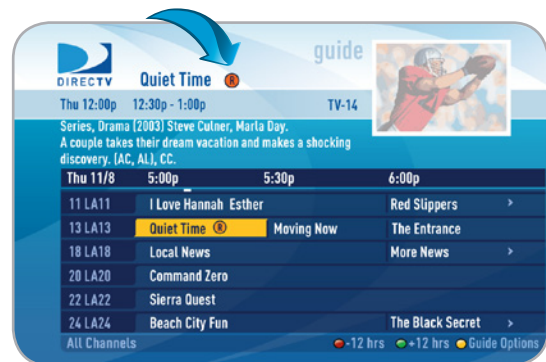

## Changing a Record Option

Some live events and even a few TV shows run past their allotted time slot. Your DVR is very smart, but it sets up all recordings based on the start and stop times the broadcasters give us for the program guide.

If you are watching while recording and you think your show might go into the next time slot, press INFO on the remote, then select “More Info” and “Recording” from the on-screen choices to see the recording options for that show. Once there you can change the stop time or any other option. To save your changes select “Save Changes” (for Standard-Definition Receivers, select “Update.”)

If your show is set to record in the future, you can find it in the guide or To Do list, then press INFO to display the Info screen. To change a recording option for that one show, select “Episode Options” and choose whichever option or options you want to change. If you want to change a recording option for every show in the series, select “Rec. Series” and then choose the options you want to change.

## Stopping an In-progress Recording

If you press the RECORD button a second time on a single show (like a movie), an on-screen message will appear giving you the choice to “Keep Recording,” “Change Recording Options, or “Stop Recording.” On a Standard-Definition receiver, the options are “Cancel This” and “Don’t Cancel.” This is an easy way to cancel a recording.



## Recording an Entire Series

### From Live TV

If the show you are currently watching is a series and not a single event (like a movie), simply press the RECORD button twice to automatically record every episode of the series. The RECORD icon is now a repeated circle R to let you know that this is a series and not a single recording.

### From the Guide

As mentioned previously, you don't have to be watching a series to record it. Simply find it in the program guide and press the RECORD button twice to record all episodes of it.

### Changing a Record Option

If you are currently watching a series show and need to extend the recording time or change any other recording option, press INFO on the remote, then select "More Info" and then "Record Series" from the on-screen choices. If you see a series set to record in the future in the program guide or the To Do List, to change a record option press INFO and select "Record Series."

### Stopping an In-progress Recording

If you press the RECORD button a third time on a series, an on-screen message will appear giving you the choice to "Keep Recording," "Change Recording Options," or "Stop Recording." On Standard-Definition Receivers, the options are "Cancel This," "Cancel All" and "Don't Cancel."



## Watching and Deleting Your Recorded Shows

To see your list of recorded shows, press LIST on the remote. Alternatively, you can also press MENU and select “My Playlist.” Use the arrow keys to highlight the desired show, press SELECT, then select “Play” (or “Resume” if you’ve already watched part of the show) to start the show. **You can use any of the DVR control buttons (like PAUSE, FFWD, ADVANCE, etc.) while watching your recorded show.** If you press STOP, the show will stop and an information screen with various options will appear. The last channel viewed in live TV will appear in the upper-right corner of the screen. To return to full-screen live TV, press EXIT or select “Done.”

If you want to delete a show from your playlist, use the arrow keys to highlight the desired show and press the RED button. You will then be asked to confirm the deletion.



Look for shortcut hints here.

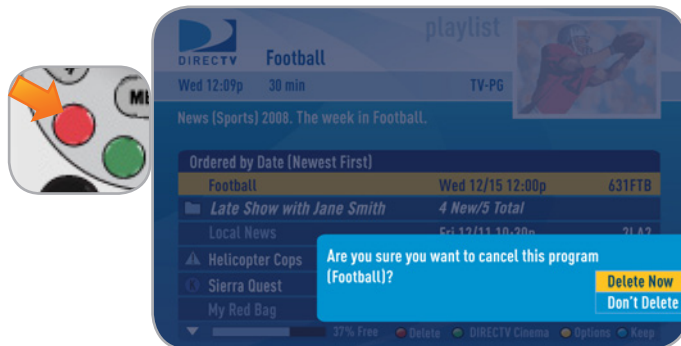

## CHAPTER 2 - DETAILED INFORMATION

---

● PROGRAM GUIDE FEATURES AND OPTIONS .....	30
● LIVE TV FEATURES AND OPTIONS .....	32
● RECORDED TV SPECIAL FEATURES.....	37
● MAIN MENU	
● OVERVIEW .....	40
● MY PLAYLIST .....	43
● DIRECTV ON DEMAND .....	54
● SMART SEARCH™ (HD DVR Receivers) .....	57
● SEARCH FOR SHOWS (SD DVR Receivers) .....	65
● MANAGE RECORDINGS .....	69
● MUSIC, PHOTOS & MORE .....	74
● CALLER ID .....	77
● TV MAIL .....	78
● PARENTAL, FAV'S & SETUP .....	79

## Filtering the Guide

There may be times when you want to temporarily trim down the channels that are shown in the guide, filtering them according to the type of program you are looking for. For example, you may want to see just sports or movies or news. In that case, press GUIDE twice to display the guide filter.

Simply use the arrow keys to highlight the category you want and press SELECT. The guide will now show only that the channels that match that category. Look for the label in the bottom left of the guide to see how it is being filtered.

**Note:** Since the filtering is temporary, it only lasts as long as you keep the program guide up on the screen.



Look here to see how the guide is being filtered.

## Guide Options

From the program guide, press the YELLOW button to display “Guide Options.”

### Sort Programs by Category

Select “Sort programs by category”, then select a category to see a list of shows in chronological order that match your sort criterion.

### Jump to a Date & Time

Select “Jump to a date & time” to quickly go to a future date and time in the guide.

### Change Favorites List

By default, your program guide displays all channels offered by DIRECTV, some of which may not be in your programming package. “Change favorites list” allows you to toggle the channels displayed in your guide between any of the following: “All Channels,” “Channels I Get” (channels you subscribe to) or a custom list of channels you have defined. The “Edit Settings” option allows you to modify the channels in your custom list. See the “Parental, Fav’s & Setup”, “Favorite Channels” section near the end of Chapter 2 for details.

### Pay Per View

Select “Pay Per View” and then the type of show you want, to see a complete listing of what is available in the guide in chronological order.

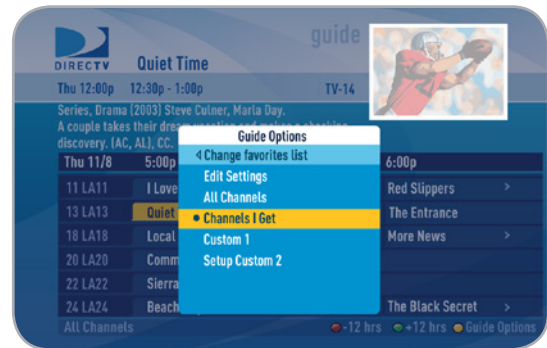
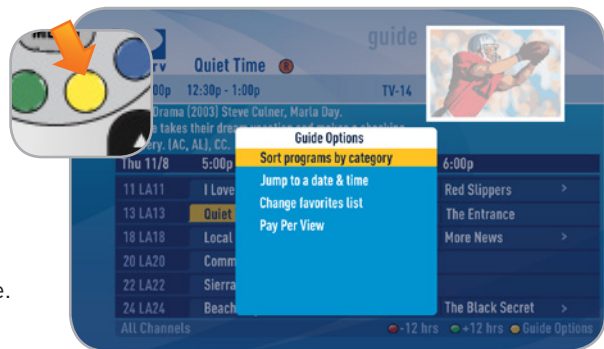

- Chapter 1
- Chapter 2
- Chapter 3
- Chapter 4
- Chapter 5

## Live TV Options

While watching Live TV you can press the YELLOW button to display a list of options to choose from: View Previous Channels, Closed Captioning, Change Favorites List and Audio Options.

### View Previous Channels

Select “View previous channels” to see a short list of the channels you have watched previously. If you select a channel from this list the receiver will tune to that channel. This is an easy way to toggle between the channels you watch most often.

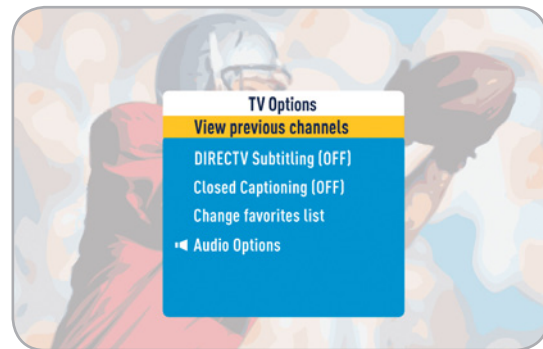

### DIRECTV Subtitling/Closed Captioning

#### High-Definition Receivers

Displays an on-screen transcription of a program’s soundtrack. Select “DIRECTV Subtitling” or “Closed Captioning” to toggle it ON or OFF. Both options display the same text so only one or the other can be “ON” at a time. The display format is the only difference so check out both to determine your preference. Standard-Definition Receivers support ‘pass-through,’ allowing your TV to display captioning when available.



## Change Favorites List

“Change Favorites List” allows you to select a custom list of channels that you want to see when channel surfing in live TV. You can toggle between “All Channels” (some of which may not be in your programming package), “Channels I Get” (channels you subscribe to) or any of your self-created lists.

You can also choose “Edit Settings” if you want to create a new favorites list. See the “Parental, Fav’s & Setup”, “Favorite Channels” section near the end of Chapter 2 for details.

## Audio Options

If the program you are watching is being broadcast with additional language audio tracks (such as Spanish), a speaker icon is displayed at the top-right of the channel banner. Select “Audio Options” and select the language you want (not all shows have an alternate language) or press the GREEN button to cycle through the available languages.



## Live Buffer

Your DVR saves programs to the hard drive instantly and continuously, while you watch. This “live buffer” lets you pause, rewind, fast forward or instant replay (jump back 6 seconds). If you start watching a program late, even if it is not set to record, you can back up to the beginning (up to 90 minutes) using REWIND, as long as you haven’t changed channels since the program started. Simply press PLAY during a show to display the progress bar and see how far back in time you can go.

**Note:** You cannot fast forward during live TV until you pause or rewind a program.

## Standard-Definition Receivers

If you change channels, you lose what is in the live buffer. If you want to flip between two shows at the same time and not lose the ability to go back in time on either channel you can record them both and then use the PREVIOUS button on the remote to toggle between them.



Progress Bar

## DoublePlay™

## High-Definition Receivers

With DoublePlay™ you can easily switch between two programs on at the same time without missing a minute of either. Your HD DVR stores up to 90 minutes of live TV on two channels. If you tune to a new channel (a third channel) the saved portion on the original channel is cleared. DoublePlay™ expires after two hours of non-use.

1. While watching one program press the DOWN arrow on your remote. A message displays confirming DoublePlay™ has started.
2. Press the DOWN arrow again and tune to the second program.
3. Now use the DOWN arrow to switch back and forth between the two programs.
4. You can pause, rewind, fast forward, slow-mo or instant replay both.

**Note:** You cannot fast forward during live TV until you pause or rewind a program.



## QuickTune

### High-Definition Receivers

Use QuickTune to get to your nine “must see” channels fast! While watching live TV, press the UP arrow on your remote control. A display with spots for nine channels will appear on screen. To fill the spots, press the GREEN button on your remote control. The channel you are currently viewing will be added to the QuickTune display. After you’ve made all your picks, press the UP arrow whenever you want to bring up the application. Use the arrow keys to highlight the channel you want to watch and then press SELECT.



## GameSearch™

Sports blackouts, a long time source of frustration and confusion for sports fans, occur when a sporting event is not televised in a certain area. But thanks to DIRECTV's cutting-edge technology, whenever you tune in to a channel with a blacked-out game, GameSearch™ recognizes the blackout and immediately looks to see if the game is on another channel. If a broadcast of the game is found, GameSearch™ displays an on-screen message that gives you the option to tune in to that channel. If it can't find one, an on-screen message will let you know the game is not available.

## Bookmarks

For shows you have already recorded, press PAUSE and then press the GREEN button to bookmark your favorite scene. You can then press and hold the FAST-FORWARD or REWIND buttons as appropriate to advance or return to that scene.

Delete a Bookmark by pressing the PAUSE button, then the DASH button (bottom left corner of the remote).



Bookmarks appear as notches in the progress bar.

## Recording from a Computer or Phone

Have you ever forgotten to set a recording and wish you could do it remotely from work or while on the go? Now you can with DIRECTV's DVR Scheduler. A brief description of the process is provided below, but go to [directv.com/dvrscheduler](http://directv.com/dvrscheduler) for all the details.

Before you can use remote scheduling, you must be registered as a user on [directv.com](http://directv.com). Once you register, do the following:

### From a PC

To schedule a recording from a PC, go to [directv.com/tvlistings](http://directv.com/tvlistings) to see an on-line version of the program guide. Navigate through the guide to find the show you want to record. Choose the DVR receiver you want the recording to go to, then indicate the priority of the recording you want to make, then click on "Record to Receiver."

**Record to Receiver**

**Note:** If you have a mix of HD and SD DVRs in your home, make sure not to pick an HD movie for your SD DVR. It will not record.



## From a Mobile Phone

To schedule a recording from a mobile phone, use your Internet browser to go to [m.directv.com](http://m.directv.com). Sign in with your user name and passcode. (As with the PC, you must be registered as a user on [directv.com](http://directv.com) before you can use remote scheduling.) Use the Search for Shows feature to find your program based on Title & Description or Channel. Pick your title from the search results and follow the step-by-step instructions to set the recording.

If you have an iPhone or iPod touch you can download the free DIRECTV application from the iPhone app store. To learn more go to [www.directv.com](http://www.directv.com).

**Note:** Remote connections vary. In rare instances, scheduled recording(s) may not be recognized. You will receive an email confirming the scheduled recording request. It is still possible the recording will not occur.



## Overview

### High-Definition Receivers

Press MENU on the remote to display the main menu.

**My Playlist** - Displays the shows you've recorded that are ready for viewing.

**Music, Photos & More** - An optional menu item that appears if you connect your DVR to your home computer network. See Appendix 2 for instructions on how to network your DVR.

**On Demand** - Connect your DVR to your high-speed Internet service to gain access to thousands of free and Pay Per View titles.

**Note:** To enjoy the DIRECTV on DEMAND service, you need a connection to the Internet, HD Access and DVR service, broadband Internet service with a connection speed of 750 Kbps or higher (DSL or cable), a network router with an available Ethernet port, a land-based phone line connection, and an available wall outlet.

**Smart Search™** - Just start typing and we'll instantly find movies, shows, people, sports, etc... for you to watch or record.

DIRECTV Plus® HD DVR Menu

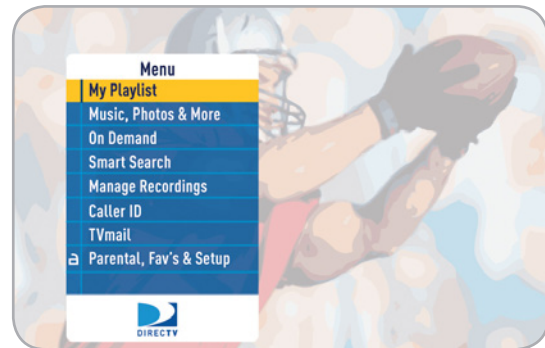



## High-Definition Receivers

**Manage Recordings** - Prioritize upcoming recordings, view recording history and change recording defaults.

**Caller ID** - Contains a log of the phone calls into your home (assuming you have a connected land line and subscribe to Caller ID service from your telephone provider).

**TV Mail** - DIRECTV Messages to you about new features, free views, tips & tricks and more.

**Parental, Fav's & Setup** - Set parental control limits, choose favorite channels for a customized program guide, and choose settings for your TV, remote, and DIRECTV® System.

DIRECTV Plus® HD DVR Menu

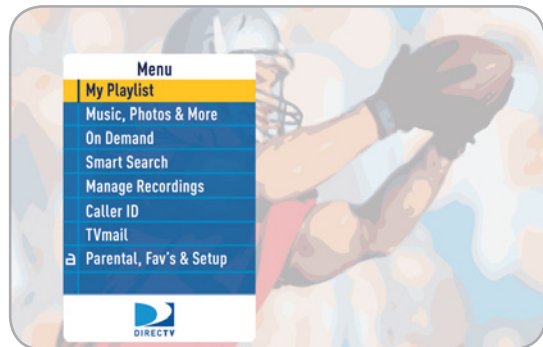

## Standard-Definition Receivers

Press MENU on the remote to display the main menu.

**My Playlist** - Displays the shows you've recorded that are ready for viewing.

**Search for Shows** - Finds shows by title, actor, channel, or keyword.

**Manage Recordings** - Prioritize upcoming recordings, view recording history and change recording defaults.

**TV Mail & Caller ID** - Contains a log of the phone calls into your home (assuming you have a connected land line and subscribe to Caller ID service from your telephone provider), as well as DIRECTV® System messages to you.

**Customer Care & Help** - Provides access to a list of help topics.

**Parental, Fav's & Setup** - Set parental control limits, choose favorite channels for a customized program guide, and choose settings for your TV, remote, and DIRECTV® System.

DIRECTV Plus® DVR Menu

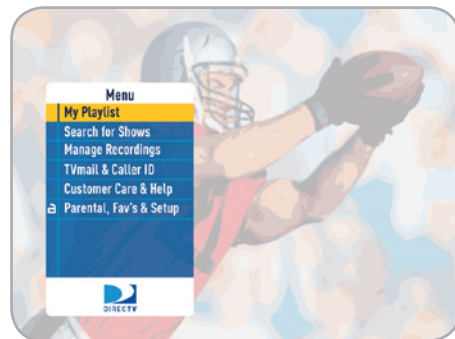

## My Playlist

The Playlist screen displays all your recorded programs. To get to the Playlist screen directly, press LIST on the remote, or press MENU and select “My Playlist.” Titles that you have not viewed yet are shown in bright, white letters, while titles that you have already viewed (partially or completely), are light blue.

The time, date and channel of each recorded program is displayed to the right of the program title. Any icon identifying program status is displayed to the left of the program title (for example, a circle K for “Keep Until I Delete”). See the inside back cover for a list of all the icons.

Highlighting a program title displays the program description, just as in the Guide. If you press SELECT or INFO on a program, an Info screen is displayed for the program that offers several actions including Play, Keep, Delete and others.

**Series programs are identified in the list with a folder icon.** For example, if you record a weekly comedy series, the title for that series is shown with a folder icon. Press SELECT on the series title to see the recorded episodes for that series. The number of new (not viewed) programs and total programs for each series is displayed to the right of the series name; for example, “2 New/5 Total.” Press PLAY on a series to play all the episodes in the folder, in order from oldest to newest. Programs recorded as a result of a search are also saved under a folder with a star icon next to it, where the title of the folder is the search name.

The screenshot shows the 'Football' playlist. An orange arrow points to the 'LIST' button on a remote control. The screen displays the following information:

- Channel: DIRECTV TV
- Program: Football
- Time: 12:09p, Duration: 30 min, Rating: TV-PG
- Description: Sports) 2008. The week in Football.
- Thumbnail: A football player in a red jersey.
- Sort Order: Ordered by Date (Newest First)
- Current Selection: Football (Wed 12/15 12:00p, 631FTB)
- Folder: Late Show with Jane Smith (4 New/5 Total)
- Local News (Fri 12/11 10:30p, 2LA2)
- Helicopter Cops (Fri 12/10 8:30p, 501 PPV)
- Sierra Quest (Fri 12/10 8:30p, 7LA7)
- My Red Bag (Fri 12/10 7:00p, 9LA9)
- Progress: 37% Free
- Actions: Delete, DIRECTV Cinema, Options, Keep

The screenshot shows the 'Late Show with Jane Smith' playlist. The screen displays the following information:

- Channel: DIRECTV
- Program: Late Show with Jane Smith
- Time: Wed 12:09p, Duration: 30 min, Rating: TV-PG
- Description: Comedy. (2008) No information available. Interview, News, CC.
- Thumbnail: A football player in a red jersey.
- Sort Order: Ordered by Date (Newest First)
- Current Selection: Late Show with Jane Smith (Yesterday 8:00p, 249 COM)
- Folder: Late Show with Jane Smith (4 New/5 Total)
- Late Show with Jane Smith (Mon 1/29 8:00p, 249 COM)
- Late Show with Jane Smith (Mon 1/28 8:00p, 249 COM)
- Late Show with Jane Smith (Mon 1/28 5:00p, 249 COM)
- Late Show with Jane Smith (Mon 1/28 11:00a, 249 COM)
- Progress: 37% Free
- Actions: Delete, DIRECTV Cinema, Options, Keep

## Playlist Options

From the Playlist screen, press the **YELLOW** button to display Playlist Options.

### Mark Programs to Delete

Select “Mark programs to delete” if you want to delete two or more programs at once.

### Sort Programs by Category

Select “Sort Programs by Category” and then select Movies, Sports, News, Kids, etc., to filter the playlist as desired. This option will help you find what you want faster, once you start to record a lot of programs.



Choose “High-Def” to sort exclusively for HD shows.

This is just a temporary filter for your list, so just press the left arrow or **BACK** to see your full Playlist again.

### Change Order of Playlist

Select “Change order of Playlist” to pick how you want to arrange the order of your recorded shows. You can sort by date with the newest at the top (that’s the factory default setting), the oldest at the top; alphabetically with A at the top, or Z at the top; by expiration date with first to expire at the top or last to expire at the top.

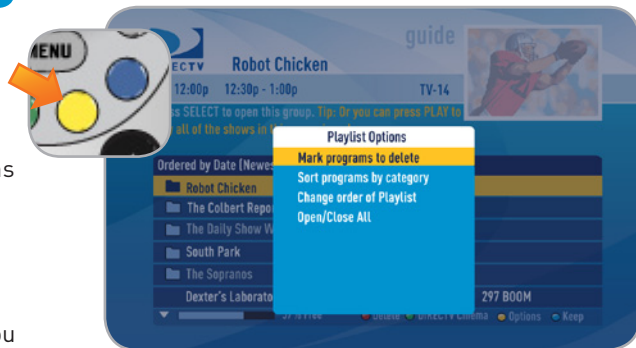

## Open/Close All

Series programs are grouped in folders in your Playlist. Select “Open/Close All” to open all of your folders so you can see each episode without having to select each series individually. You can also use this option to close them all.

## Managing My Playlist

Your DVR has lots of recording space but it is possible to fill up the hard drive if you record regularly. A quick way to check how much space you have available is the Disk Space Bar.

## Disk Space Bar

The Disk Space bar is at the bottom of your Playlist. It shows the approximate amount of space available on your disk at any given time.

The Disk Space bar shows programs you have designated “Keep Until I Delete” in dark blue, programs subject to expiration or automatic deletion in light blue, and the remaining unused disk space that is available for recording in black.

When your disk is full, the oldest shows (viewed or not) are automatically pushed out to make room for the new ones. If you have a show that you don’t want pushed out, press the BLUE button to “Keep” it in your Playlist until you delete it.



DIRECTV Football playlist   
 Wed 12:09p 30 min TV-PG  
 News (Sports) 2008. The week in Football.

Ordered by Date (Newest First)		
Football	Wed 12/15 12:00p	631FTB
Late Show with Jane Smith	4 New/5 Total	
Local News	Fri 12/11 10:30p	2LA2
Helicopter Cops	Fri 12/10 8:30p	501 PPV
Sierra Quest	Fri 12/10 8:30p	7LA7
My Red Bag	Fri 12/10 7:00p	9LA9

37% Free ● Delete ● DIRECTV Cinema ● Options ● Keep

## Keep

Highlight the show you want to keep and press the BLUE button on your remote. A blue circle K icon will appear next to the program title indicating it will be kept until you delete it. You may be tempted to make all of your recordings “Keep Until I Delete”, but if your hard drive ever fills up, new recordings can’t take place.

Another way to manage your Playlist is to delete recordings you no longer want.

## Delete

Highlight a single show or a series (indicated by a folder icon) and press the RED button to delete it. If you delete a folder, all episodes of that series will be deleted. Don’t worry about pressing the RED button accidentally. You will always see a confirmation message before you delete anything.



Note that HD programs take up more disc space than SD. Thus, you may want to record your favorite content in HD, while recording other shows in SD to optimize your use of the available recording capacity.

## DIRECTV Cinema™ on Demand

Press the GREEN button to go to the DIRECTV Cinema™ on Demand home page.



## DIRECTV® Whole-Home DVR Service

## High-Definition Receivers

With DIRECTV's Whole-Home DVR service and the proper equipment, it's like having a DVR in every room. Now even rooms with HD Non-DVR receivers can schedule and watch recorded programs. Start watching a recorded program in one room, stop it, and then continue watching it in another room.

Here's how it works:

### 1. Network Your Receivers:

When your HD DVR and HD Non-DVR receivers are networked, it allows them to share content. This is typically completed by an installer during your installation appointment. To learn more about upgrade and eligibility requirements, go to [directv.com/wholehome](http://directv.com/wholehome). To get a quick understanding of how recorded content is shared by your household, skip to step 7.

**Note:** To access DIRECTV® Whole-Home DVR service functionality, you need a DIRECTV Plus HD DVR receiver (models HR24, HR20-HR23 with DECA), a second Whole-Home-capable receiver (models H24, HR24, H21, H23, HR20-HR23 with DECA), a SWiM network, HD Access, DVR service and DIRECTV® Whole-Home DVR service. Limit one remote viewing per DVR at a time.



## High-Definition Receivers

### 2. Activate DIRECTV® Whole-Home DVR Service:

Once DIRECTV® Whole-Home DVR service is activated on your account, press the LIST button on your remote. The message on the right will display, confirming the service has been enabled. Select "Continue".

**Note:** Service activation and location naming are typically performed by the installer during your installation appointment.

### 3. Name Your Locations:

You'll be prompted to give each receiver a name. We refer to this as "Location". We recommend using a name that you'll easily associate with the room or it's location, such as, "Living Room." The name must be 14 characters or less. You must be at the receiver to assign its name.

After you've assigned a Location Name, you can change it as follows: Press MENU, select "Parental, Fav's & Setup," "System Setup," "Whole-Home" and then "Name Location."

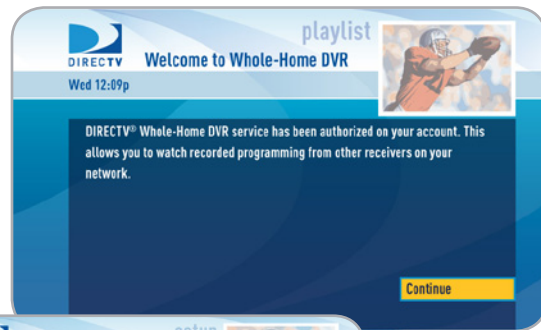



## High-Definition Receivers

## 4. Set Playlist Sharing Options (HD DVR only):

During initial setup, if the receiver is an HD DVR, you'll be prompted to set the following Playlist sharing options:

- **Share Playlist**

An HD DVR has the option to share its Playlist with other receivers. Let's say you have an HD DVR in your Den, an HD DVR in your Master Bedroom, and an HD Non-DVR in your Kitchen. If you set Share Playlist to "No" in the Master Bedroom, the other rooms (Den and Kitchen) won't be able to access the Master Bedroom's Playlist.

- **Allow Deletion**

An HD DVR has the option to prevent another location from deleting programs that were recorded by that an HD DVR. In our previous example, if the DVR in the Den is set to allow deletion "From this room only", a person trying to delete a program (recorded in the Den) from the Master Bedroom or Kitchen would be prevented from doing so.

You can change sharing options at any time. Press MENU, select "Parental, Fav's & Setup," "System Setup," "Whole-Home" and then "Share Playlist."

## 5. View Status:

To view the Whole-Home status for all your connected HD DVRs, press MENU, select "Parental, Fav's & Setup," "System Setup," "Whole-Home" and then "Status." This screen indicates if DIRECTV® Whole-Home DVR service is authorized, as well as the Playlist sharing settings for all networked HD DVRs.

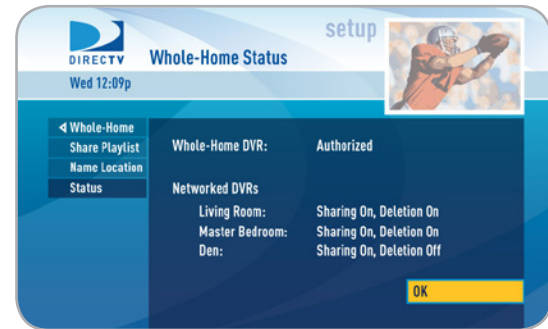
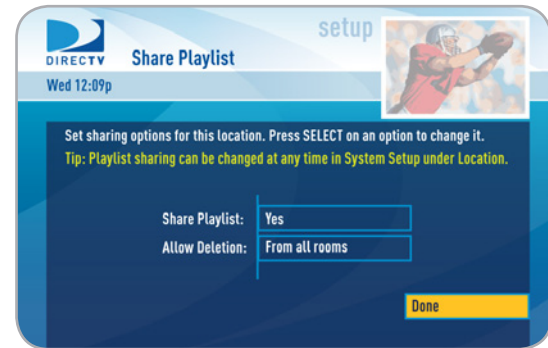

## High-Definition Receivers

### 6. Record Programs:

If you're in a room with an HD DVR, and you've authorized DIRECTV® Whole-Home DVR service, you'll still record programs in the same way you did before. See Chapter 1, "Recording Programs" for details.

If you're in a room with an HD Non-DVR receiver, once you authorize DIRECTV® Whole-Home DVR service you're able to request programs to record.

- To record a show you're currently watching or to record a highlighted program in the Guide, press the orange REC (record) button. A message displays on screen asking you to select the HD DVR you would like to record on; then select either "Record Once" to record the current episode, "Record Series" to record the entire series or "Do Nothing" to cancel your request.

**Note:** Pressing the REC button twice to record a series or pressing it three times to cancel the request does not work on Non-DVR receivers.

You can also book a recording from a program's Info screen. To record a program you're currently watching or to record a highlighted program in the Guide, press the INFO button and select either "Record Once" or "Record Series."

- If your recording (requested from a Non-DVR receiver) conflicts with other recordings already scheduled on the DVR, a message will display letting you know that your program cannot be recorded.

**Tip:** Adding a second HD DVR to your DIRECTV® System doubles your recording capacity. Don't worry about having to remember which DVR you recorded your shows on. Whole-Home DVR service keeps things simple by giving you a single, unified playlist of all your recordings on any connected TV.

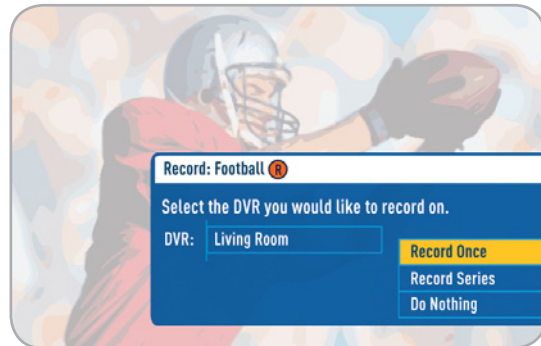

### High-Definition Receivers

- Recordings can only be managed from the HD DVR receiver that recorded the show (even if they were originally requested from a Non-DVR receiver). In order to check the status of scheduled recordings on the To Do List or to change the priority of a series you've scheduled to record, go to the HD DVR and press MENU, select "Manage Recordings" for options.

## 7. Watch Recorded Programs:

By networking your receivers, the recordings from all the HD DVRs in your household are combined into a "shared" Playlist. The shared Playlist is accessible by all networked receivers, even if the receiver is not a DVR! To access the Playlist, press the LIST button on the remote control or press MENU, and select "My Playlist". Highlight a show and press SELECT to play. If you've already watched part of the show in another room, you can select "Resume" to pick up where you left off. You can use any of the DVR control buttons such as PAUSE, FFWD, ADVANCE, etc... while watching your recorded show.

You can limit access to programs with Parental Controls. See Chapter 2, "Parental Controls for details". Your parental control settings restrict access to both recorded and live programs. Parental controls must be set at each receiver.

To delete a program from your Playlist, use the arrow keys to highlight the desired show and press the RED button. You'll then be asked to confirm the deletion.



**Note:** Only two locations can access a recorded program at the same time (the HD DVR the program was recorded on and one other location). If a third location tries to playback a recording, a message will display explaining that the program is not available.

## On Demand

The DIRECTV on DEMAND service provides access to thousands of movies, shows, sports and more, that you can download and watch anytime you wish. Many are free, but we also offer a full selection of the best DIRECTV Cinema™ movies and Pay Per View events.

### Finding On Demand Programming

To see what's available, Press MENU, select "On Demand", then select either:

- Channels On Demand (Channel 1000)
- Cinema on Demand (Channel 1100)
- Showcases (Channel 1999)

**Note:** In addition to getting here via the main menu, you can also tune directly to the channel using your remote control.



## Channels On Demand Home

Channel 1000 is the DIRECTV on DEMAND home page from which you can access thousands of movies, shows, sports and more. Browse the listings by category such as, Movies, Kids and Family, TV Series, etc..



You can also choose “High-Def” to filter the listings to see only HD titles.

**Note:** To enjoy the DIRECTV on DEMAND service, you need a connection to the Internet, HD Access and DVR service, broadband Internet service with a connection speed of 750 Kbps or higher (DSL or cable), a network router with an available Ethernet port, a land-based phone line connection, and an available wall outlet. If your receiver was connected to the internet during your professional installation, you're all set. If not, see Appendix 2, “How to Network Your DVR” for instructions.

Be sure to check out your favorite programmer's home page to see previews of their exciting new shows, or catch episodes you may have missed. Just like the Channels On Demand home page which is located on Channel 1000, these programmer home pages are located in the 1000s. Simply add a 1 in front of the regular DIRECTV channel number. For example, DIRECTV original programming is shown on channel 101. The 101's DIRECTV on DEMAND channel is 1101.



## DIRECTV Cinema™ on Demand

Channel 1100 is the DIRECTV Cinema™ on Demand home page where you can access all of the biggest and best movies. If your DVR is broadband connected you will have access to the entire DIRECTV Cinema™ on Demand library. But even if you're not connected to the Internet, we'll have a selection of top movies available for you to watch right now.

## Showcases

Showcases offers you DIRECTV content such as instructional videos, behind the scenes clips and video extras, information about DIRECTV sports subscriptions, special offers, trailers and more.

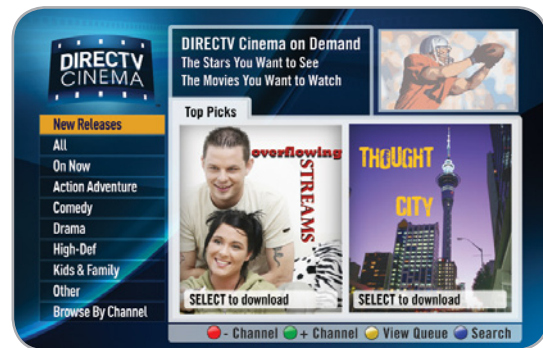

## Downloading On Demand Shows

To record DIRECTV on DEMAND programs, browse the home pages to find a title you want to download. Select the title to display the program's info screen. From here, select "Add to Queue" and the program will be placed in your download queue. An orange circle icon with the letter "Q" in the center, appears next to the program title to indicate that it has been scheduled for download. Once a program starts downloading, it appears in your Playlist and is ready to be viewed.

**Note:** HD shows will take longer to download than SD shows.

Some programs are available to watch immediately and do not require download. Select the category "On Now" for available titles. Also, if you're browsing titles and see one with a green circle icon with a white check mark in the center, this also indicates that it's "On Now."

## Checking the Download Queue

After adding a show to your queue, press the YELLOW button to see the VOD Queue screen, which lists the shows you have waiting to download. The first title is currently downloading and the ones below it are next in line.

Highlight a title and press the RED button to delete it from the queue. Highlight a show and press the GREEN button to move it to the top of the queue. Highlight the arrow to the right of a title and use the UP or DOWN ARROWS to adjust download priority.



## Pausing Your Downloads

If your home network gets congested, you can pause your downloads by pressing the YELLOW button from the Queue screen. Press the YELLOW button a second time to resume downloading. To get to the Queue screen from Live TV, press MENU, select "Manage Recordings", then select "Queue."

## Playing Your Downloaded Shows

Once the program has started downloading, it will appear in your Playlist like the rest of your recorded shows. How quickly it downloads depends on the speed of your broadband connection. If it is fast, you can start watching your show immediately while it is downloading. If the connection is slow, you may start watching the show, but when you "catch up" to what has been downloaded, the show will pause. The color of the download progress bar indicates whether the program will pause. Green means that it will not pause. Yellow means it might. Red means the program will eventually pause if you start watching now. (Note: Program playback pauses, but the download continues.)

You can easily tell which shows in your Playlist came from DIRECTV on DEMAND by the "VOD" label next to the program title. "VOD" stands for "Video on Demand."





## Smart Search™

Finding something to watch or record is fast and easy! Whether you're looking for a movie, show, person, channel, sport, etc... as soon as you start typing we'll instantly give you results. Smart Search finds all matching programs within the 14-day program guide as well as, within the DIRECTV on DEMAND library (if you're connected to your home network).

### Suggested Searches:

When you first get to the search screen, select a poster for recommendations such as, interesting new programs, the most popular shows this week or programs about current events.

Press MENU on your remote, select "Smart Search", and start typing. There are two ways to input your search term:

1. **Number keys on your remote** – Use the number keys on your remote like a cell phone to enter your search term. To erase letters, press the LEFT ARROW.
2. **On-screen keypad** – Highlight a letter in the keypad and press SELECT. To erase the last letter, select DEL (delete) or select CLR (clear) to start over.

**Tip:** There's no need to enter articles like "The" or "An" preceding your search term.



## Search Results:

Results appear as soon as you type in the first letter of your search term; but with each character entered, your results become more precise. The label on the right side of each item in the results list that tells you what type of content it is. The content types are: Movie, Show, Person, Channel #, or Category. There are many categories but a few examples include: Action/Adventure – Movie, Comedy – Movie, Romance – Movie, Baseball, Basketball, Football, Cooking and Travel. When you see what you're looking for in the results list, highlight it and press SELECT.

- If you select a **Movie or Show**:

A list of all upcoming airings of the movie or show displays with a short description of the program at the top of the screen. Highlight an airing and press the orange REC (record) button on your remote to schedule it to record. Alternately, press SELECT on a highlighted listing for detailed program info and additional options.

A few options you may want to try are “Cast & Crew” and “Similar Shows”. Cast & Crew provides you with the actors, directors, producers, composers, etc. that worked on the movie or show. Select a person's name for a list of their other programs available in the program guide. Similar Shows offers titles of shows that are similar to the current program, such as prequels and sequels.



- If you select a **Person** (i.e. Actor, Director or Producer):

A list of their upcoming programs displays. You'll have the option to highlight and select individual programs to record or you can select "Autorecord" to record all programs matching the name of the Person you searched for. Autorecords are persistent. Therefore, any time a program becomes available in the Guide that matches your Person, it will automatically be recorded. To cancel an autorecord, press MENU, select "Manage Recordings" and select "Series Manager". Highlight the autorecord and press the RED button.

You can also review the person's "Filmography" which lists the movies or TV Shows spanning their career. In addition, "Awards" lists the titles of all the person's movies or shows that were nominated for, or won, an award.

**DIRECTV Smart Search** search 

Wed 5:00p

Press SELECT on the letters or use numbers keys on the remote like a cell phone. When you see your show, highlight it, then press SELECT.

A	B	C	D	E	F	SPI	
G	H	I	J	K	L	Spinning Around the House	Show
M	N	O	P	Q	R	Spill, John	Person
S	T	U	V	W	X	Spill, Michael	Person
Y	Z	1	2	3	4	Spill, Zoe	Person
5	6	7	8	9	0	Spina, Enrico	Person
CLR	SPC	DEL				Spinelli, Frederico	Person
Recent Searches							

▼ Keyword Search for "SPI"

**DIRECTV Michael Spill** search 

Wed 5:00p 5:00p - 6:45p TV-23

**Autorecord**

**Filmography**

**Awards**

**Done**

 Actor  
 Birth Place: San Diego, California  
 Date of Birth: 04/07/1970

Upcoming Appearances: 16 Total

Appealing to the Heart	Today	4:00p	T100 CINEMA
The Secret of My Father	Today	7:05p	T101
The Secret of My Father	Today	9:00p	T101HD
Revenge in Washington	Today	10:00p	T101HD
Interview: Michael Spill	Today	11:30p	T101HD

# Smart Search (High-Definition Receivers)

- If you select a **Channel**:

A list of all programs available on that channel displays in chronological order. Press select on “Tune Now” to view that channel. You can also highlight a program and press the orange REC (record) button on your remote to schedule it to record or press SELECT on a highlighted program for detailed program info and additional options.

The screenshot shows the DIRECTV Smart Search interface. At the top left is the DIRECTV logo and the text 'Smart Search'. At the top right is the word 'search' and a small image of a football player. Below this, it says 'Wed 5:00p'. A message reads: 'Press SELECT on the letters or use numbers keys on the remote like a cell phone. When you see your show, highlight it, then press SELECT.' Below the message is a grid of search results:

A	B	C	D	E	F	BL_	
G	H	I	J	K	L	Bloomberg	353
M	N	O	P	Q	R	Boomerang	297
S	T	U	V	W	X	Bravo	273
Y	Z	1	2	3	4	BYU TV	374
5	6	7	8	9	0	Cable Response TV	243
CLR	SPC	DEL				Cable Response TV INFO #2	268

At the bottom left, there is a 'Recent Searches' button. At the bottom right, there is a dropdown arrow and the text 'Keyword Search for "BL"'.

The screenshot shows the DIRECTV Bloomberg channel interface. At the top left is the DIRECTV logo and the text 'Bloomberg'. At the top right is the word 'search' and a small image of a football player. Below this, it says 'Wed 8:00p'. On the left side, there is a 'Tune Now' button with a 'Done' button below it. A message reads: 'Press SELECT on Tune Now to view channel. Select a program below to view more info.' Below the message is a list of programs:

News Now	Today	11:00a	353
Financial News Now	Today	11:30a	353
Investments	Today	12:00p	353
World of Finances	Today	12:30p	353
Financial News Now	Today	1:00p	353

At the bottom left, there is a dropdown arrow.

- If you select a **Category**:

Sample categories are: Movies, Science Fiction, Baseball, Basketball, Football, Cooking, Exercise/Fitness, Travel, etc...

A list of upcoming programs matching that category displays. Highlight a program and press the orange REC (record) button on your remote to schedule it to record or press SELECT on a highlighted listing for detailed program info and additional options.

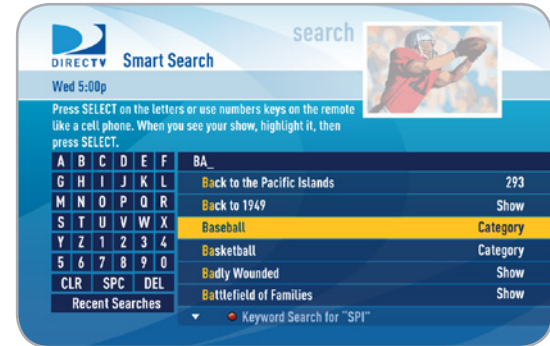

## Keyword Search

A keyword search is an in-depth search that looks for programs by matching a keyword (of your choice), to a program's title or description. The more specific you can be with your keyword, the better your search results will be. If you enter a word that's part of a larger word, you may get unintended results. For example, if you enter "cats" you may get results that include "Catskills Mountains" as well as, "Cats in Washington."

You can enter a phrase such as, "Wild Cats" but it must match the program information exactly. It's usually better to use single words.

The screenshot shows the DIRECTV Smart Search interface. At the top, the DIRECTV logo is on the left, "Smart Search" is in the center, and "search" is on the right next to a football player icon. Below the logo, it says "Wed 5:00p". A prompt reads: "Press SELECT on the letters or use numbers keys on the remote like a cell phone. When you see your show, highlight it, then press SELECT." On the left is a keyboard layout with letters A-F, G-L, M-R, S-X, Y-Z, and numbers 1-4, 5-8, 9-0, plus CLR, SPC, and DEL keys. Below the keyboard is a "Recent Searches" button. On the right is a list of search results for "CATS":

CATS	
Cats in Washington	Movie
Catskills Mountains	Movie
Mrs. Catsis	Movie
Prehistoric Cats	Show
All About Cats	Show
The Catsue Village	Show

At the bottom, a dropdown menu shows "Keyword Search for 'CATS'".

The screenshot shows the DIRECTV Smart Search interface for the keyword "WILD CATS". The layout is identical to the first screenshot, but the search results list is different:

WILD CATS	
Wild Cats in Brazil	Show
The Wild Cats Territories	Show
Adventures of the Wild Cats	Movie
Wild Cats Mountains	Movie
Learning About Wild Cats	Show
Here Come the Wild Cats	Show

At the bottom, a dropdown menu shows "Keyword Search for 'WILD CATS'".

To perform a Keyword search:

- Press MENU on your remote and select “Smart Search”.
- Type in your keyword and press the RED button on your remote.
- Select a category to narrow your results or if you don’t want to narrow, select “All”.
- A list of programs matching your keyword displays.

When your search results display, you’ll have the option to highlight and select individual programs to record or you can select “Autorecord” to record all programs matching your keyword. Autorecords are persistent. Therefore, any time a program becomes available in the Guide that matches your keyword, it will automatically be recorded. To cancel an autorecord, press MENU, select “Manage Recordings” and select “Series Manager”. Highlight the autorecord and press the RED button.

**Smart Search**

Wed 5:00p

Press SELECT on the letters or use numbers keys on the remote like a cell phone. When you see your show, highlight it, then press SELECT.

A	B	C	D	E	F	CATS
G	H	I	J	K	L	Cats in Washington
M	N	O	P	Q	R	Catskills Mountains
S	T	U	V	W	X	Mrs. Catsis
Y	Z	1	2	3	4	Prehistoric Cats
5	6	7	8	9	0	All About Cats
CLR	SPC	DEL				The Catsue Village

Recent Searches

Keyword Search for "CATS"

---

**Search by Keyword (Narrow)**

Wed 8:00p

Press SELECT on a category and subcategory to reduce search time and number of results.

Search: CATS

- All
- Movies
- Sports
- High-Def
- News
- Kids

Category 13 Total Subcategory

---

**Autorecord**

Done

These programs match your search. Select a program in the list to view more info.

Cats in Washington	Today	5:00p	539
House of the Anans	(VOD)		1000
The Entrance	(VOD)		1000
Appropriate your Culture	Fri 11/9	7:00a	505
Word of Finances	Fri 11/9	7:20a	202

RED button

## Recent Searches

If you've ever used the search feature to find a favorite movie, actor, sports team etc...you can reuse your search (and avoid extra typing). Your receiver displays your 25 most recent searches.

- Press MENU on your remote and select "Smart Search".
- Highlight and select "Recent Searches" at the bottom of the keypad.
- Highlight a previous search from the list and press SELECT.

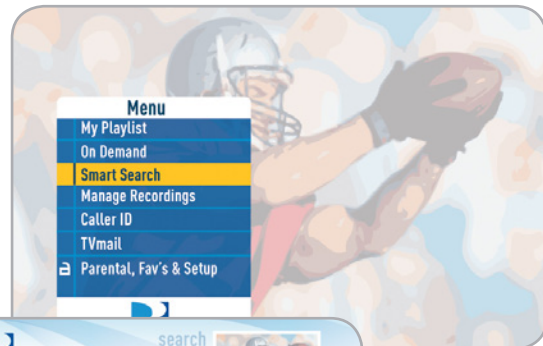



## Search for Shows

Use the “Search for Shows” option to find programs based on Title, Person, Channel or Keyword. This powerful tool finds all programs that match your criterion within the 14-day program guide as well as the DIRECTV on DEMAND service (if you are connected to your home network).

To start your search, press MENU on your remote, select “Search for Shows”, and then select the search type: “Title”, “Person”, “Channel”, “Keyword” or “Recent Searches.”

Using the on-screen keypad, enter one letter at a time by highlighting the letter you want and pressing SELECT. Select DEL (Delete) to get rid of the last letter or CLR (Clear) to start over if you make a mistake. You do not have to enter the initial article like “The” or “An.” Each time you enter a letter, the search becomes more precise. You don’t always have to enter the complete word. Just the first few letters will usually get you close enough.

- If you select “Title”:

Use the on-screen keypad to type in the first 3-4 characters of your title. A list of all movie and show titles matching your search term will display. If a program is being broadcast on more than one channel, a folder icon will display next to the title. DIRECTV on DEMAND titles have a VOD icon next to them. Highlight a title and press SELECT for program info and recording and other options.



## Search for Shows (Standard-Definition Receivers)

- If you select "Person":

Use the on-screen keypad to type in the first 3-4 characters of person's last name. You'll see a list of names which include actors, actresses and directors. After you select a name, you'll be given the option select a category to narrow your search results. If you don't want to narrow, select "All".

A list of program titles will display. Highlight and select an individual program to record or select "Autorecord" to record all programs for the person selected. Autorecords are persistent. Therefore, any time a program becomes available in the Guide that matches your Person, it will automatically be recorded.



- If you select “Channel”:

Use the on-screen keypad to enter the first few letters of the channel name. For example, type in “BL” to find Bloomberg. Highlight and select the desired channel from the list.

**DIRECTV Search by Channel**

Mon 11:19p

Press SELECT on the first letters of the channel name until you see it listed. Press RIGHT to highlight the list, then select the channel to view programs.

A	B	C	D	E	F	BL
G	H	I	J	K	L	Bloomberg 353 BTV
M	N	O	P	Q	R	Boomerang 297 B00M
S	T	U	V	W	X	Bravo 273 BRV0
Y	Z	1	2	3	4	BYU TV 374 BYU
5	6	7	8	9	0	Cable Response TV 243 CRTV
CLR	SPC	DEL				Cable Response TV INFO #2 268 IRTV

A list of programs scheduled on that channel will display. Highlight a title and press SELECT for program info and recording and other options.

**DIRECTV News Now**

Thu 5:00p

Business/Financial. (2008) .

Programs: 353 BTV

< News Now	Today	11:00a	353
Financial News Now	Today	11:30a	353
Investments	Today	12:00p	353
World of Finances	Today	12:30p	353
Financial News Now	Today	1:00p	353

• -1.5hrs • +1.5hrs

## Search for Shows (Standard-Definition Receivers)

- If you select **“Keyword”**:

A keyword search is an in-depth search that looks for programs by matching a keyword (of your choice), to a program’s title or description. The more specific you can be with your keyword, the better your search results will be.

- Press MENU on your remote and select “Search for Shows,” then select “Keyword.”
- Type in your keyword and select “Continue”.
- Select a category to narrow your results or if you don’t want to narrow, select “All”.
- A list of programs matching your keyword displays.



- If you select **“Recent Searches”**:

This handy feature displays a list of your 25 most recent searches in case you want to update or reuse a search you used previously.

- Press MENU on your remote, select “Search for Shows” then select “Recent Searches.”
- Highlight a previous search from the list and press “SELECT”.



## Manage Recordings

Once you have scheduled recordings, you can find the status and history of those recordings by pressing MENU and selecting “Manage Recordings” to see the following options: To Do List, Queue, History, Purchases, Series Manager (or Prioritizer), Manual Record (or Manual) and Record Defaults. These features are described on the next few pages.

### To Do List

The **To Do List** displays recordings your DVR is scheduled to make in the future. Icons next to the titles indicate whether the recording is a single event, part of a series, or an autorecord based on a person or keyword search. The list is ordered by time with the next recordings at the top and the furthest in the future at the bottom. You can use this screen to make sure your recordings are properly scheduled or to delete future scheduled recordings you no longer want to record. The To Do list does not display DIRECTV on DEMAND programs scheduled for download over the Internet; these are shown in the Queue screen.

Deleting single shows is easy: Simply highlight the show you want to delete and press the RED button on the remote. A confirmation message will appear before you can delete the show.

If you want to delete an entire series from the To Do List, select the show, select “Series Options”, then select “Cancel Series.”

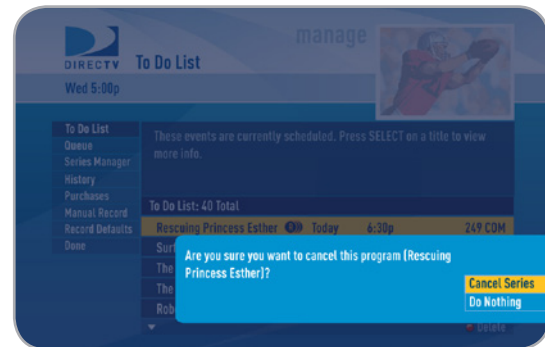
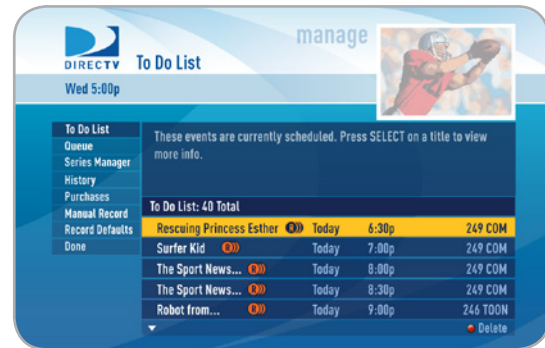

## Queue

The Queue screen displays DIRECTV on DEMAND titles that are in the queue waiting to be downloaded to the hard drive. See the DIRECTV on DEMAND section earlier in this chapter for details. Programs that have completed downloading are displayed in the Playlist.

## History

Provides status information for every recording scheduled, whether they were completed, canceled or deleted. If you think something should have been recorded, but wasn't, check here to look for an explanation.

## Purchases

Provides status information for all Pay Per View programs that were bought and, if viewed, the date and time.



## Series Manager (or Prioritizer)

The Series Manager screen (or Prioritizer screen on Standard-Definition Receivers) displays a prioritized list of all the series you've scheduled to record. If there is a series recording conflict and the receiver must choose which show to record, it uses this list to determine the priority. As you set up series recordings, the most recent series goes to the bottom of the list in last priority. You can change the order of the priority at any time by selecting "Series Manager", selecting the show you want to move, moving the highlight to the right, and then using the arrow keys to promote or demote the series.

There are a couple of color key short cuts on this screen as well. Use the RED button to delete an entire series. Use the GREEN button to move a highlighted show to the top of the list in one press.

You can also adjust the recording options used for a particular series from this screen. Select the series you want, then select "Series Options" (or Rec. Series) and change the recording options as desired.

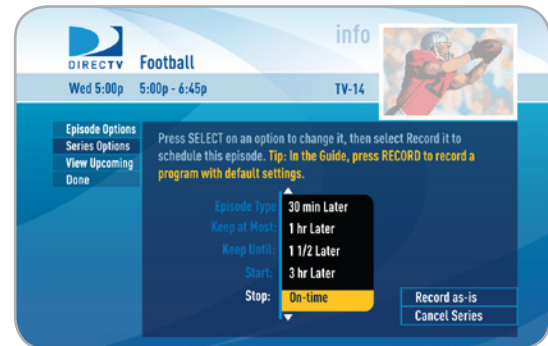

## Manual Recordings

There may be times when you want to set up a manual recording based on channel, time and date. In this case, select Manual Record (or Manual) and enter all of the options as you wish, including whether you want this to be a one-time or recurring recording (i.e. every Tuesday), channel, day and date, start time and duration. You can schedule a manual recording up to 14 days in advance.





## Record Defaults

The Record Defaults screen lets you set the recording options you want the receiver to use every time it does a recording. The receiver's default settings work best in the vast majority of cases, but you may want to change them to your personal preferences.

- When recording a series, the **Episode Type** gives you the option to record first run only, repeats only, or both.
- The **Keep at Most** option lets you decide how many episodes you want to keep: 1, 2, 3, 4, 5, 10 or All. If you select "All Episodes" for a show that appears many times in the guide, you may find it uses disk space rapidly.
- The **Keep Until** option lets you keep a recording until you delete it or until the disk is full, in which case the DVR can delete it automatically if the disk fills up. A recording that is labeled "Keep Until I Delete" will never be deleted until you do it manually; if all of your recordings are labeled that way and the disk fills up, no new recordings will occur until you manually delete some of your "Keep Until I Delete" recordings.
- Finally, the **Start** and **Stop** options let you adjust the times of your recordings to ensure you don't miss a thing. Keep in mind that starting early and ending late on all of your recordings may create more recording conflicts than if you started and stopped on-time (according to the program guide schedule). If you find a particular series runs habitually late or early, it is better to adjust that series using the program's Info screen rather than set the recording defaults, which would affect all of your DVR recordings. Press MENU, select "Manage Recordings," then select "Series Manager" (or Prioritizer). Select the program you want to adjust, then select "Series Options" (or Rec. Series).



## Music, Photos and More

“Music, Photos & More” is an optional menu item, only seen if your DVR is connected to your home network, see explanation below. Compatible models include the DIRECTV Plus® HD DVR (models HR20 or later) or DIRECTV Plus® DVR (model R22). Other models may support DIRECTV Media Share in the future.

Your DIRECTV Receiver can be connected to your home network to show photos and play music and videos that you have saved on your personal computer. You must have at least one personal computer running a media server (e.g. TVersity, Windows Media Player, Intel Viiv) in your network for this service to work. The setup is similar to that used for the DIRECTV on DEMAND service. See Appendix 2 for details on how to connect your DVR to your home network. Please visit [directv.com/mediashare](http://directv.com/mediashare) for more information.

Once your DVR is properly connected to the media server on your home network, a new item will appear in the main menu: **“Music, Photos & More.”** When selected, the DIRECTV Media Share screen will display.

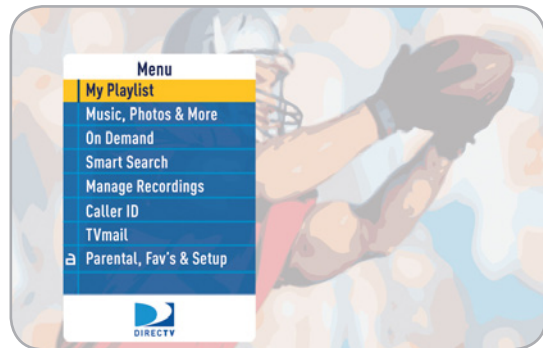

- Select “Music” to go to the Music submenu, where you can access music by Artist, Album, Song, Playlists and Channel. Your favorite music will play as you watch TV or view photos from your PC.

Once the desired songs are selected from the Music submenu, the song’s information will display on the Progress bar.

- Select “Photos”, go to the Photos submenu. Select “Browse” to see several photos at once.

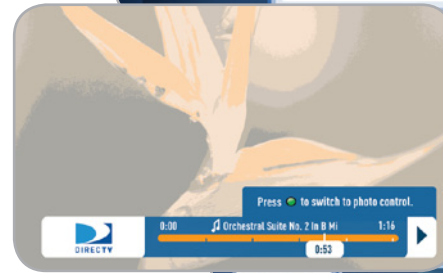

You can listen to music and display photos at the same time.

- Press the GREEN button on your remote to toggle between music, photos and video control modes. Pressing the STOP button while in music control mode stops the music from playing and the audio from the current channel is then heard.

Pressing the STOP button while in photo control mode stops the display of photos and displays the video from the current channel.



## Caller ID

This feature allows you to configure and review your Caller ID (if you have that phone service and your receiver is connected to the phone line).

**Note:** You must subscribe to caller ID service through your phone company and your receiver must be connected to the phone line.

To set up your receiver to display an onscreen notices whenever you receive a call, press MENU and select "Caller ID," then select "Turn on Notices." This will toggle the option to now read "Turn off Notices."

You can review your 25 most recent calls in the call log at any time. To see your call log, press MENU, select "Caller ID" then select "Call Log." Highlight and select a name to delete that listing from your log.

**Note:** On Standard-Definition Receivers, set up your receiver to display onscreen call notices as follows: Press MENU, select "TVmail & Caller ID," then "Turn On Notices."  
To display your Call Log, select "TVmail & Caller ID," select "Edit Settings", then select "Caller ID."

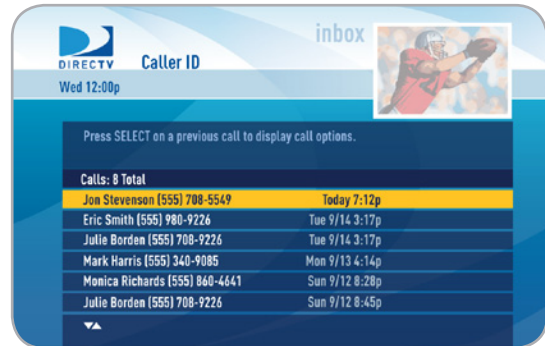

## TVmail

DIRECTV sends messages to you via satellite for important news items or special promotions. We also summarize important software changes or new features that we download to your receiver. **When you have new mail, the “envelope” message icon will appear in the channel banner of any program you are watching.**

Simply press MENU and select “TVmail,” to see your DIRECTV Messages.



### Standard-Definition Receivers

On Standard-Definition Receivers, press MENU, select “TVmail & Caller ID,” then “TVmail” to see your messages.



## Parental, Fav's & Setup

Selecting "Parental, Fav's & Setup" in the main menu displays items that lets you customize and adjust your DIRECTV viewing experience.

- Select **"Parental Controls"** to limit what ratings your children are allowed to watch, how much they can spend for Pay Per View shows or even what hours they can watch DIRECTV Programming.
- Select **"Favorite Channels"** to set up your own personal list of favorite channels and then use it in the program guide and while surfing live TV for a more customized experience.
- Select **"System Setup"** to adjust and configure how you want your TV and DIRECTV® System to work together.

### Parental Controls

Parental Controls enable parents to place certain restrictions on just who's watching what, and requires a passcode to view restricted programming. Whether it's for mature content, spending amounts, or even the number of hours of TV watching allowed, you're always able to keep limitations where you want them for the whole family.

Press MENU, select "Parental, Fav's & Setup," select "Parental Controls," and then "Edit Settings." You'll see the current status, showing any restrictions. The system default is "unlocked" for all categories.



### ● Lock Now

After setting the restrictions you want (see below for options), choose “Lock Now” from the left menu. You’ll be asked to create a passcode. You’ll want to make it easy enough to remember, but hard enough so someone can’t guess what it is! This passcode will be your entry to unlocking and adjusting limitations in the future.

An on-screen message will appear whenever anyone tries to tune to a channel or program that has been restricted, or attempts to spend or watch beyond limitations set. He or she will not be allowed to proceed without the passcode. Using your passcode, you can easily override the limits.

Making multiple entries aimed at guessing the passcode is discouraged by a time delay; each invalid passcode entered lengthens the delay for subsequent entry by one second.

To change your passcode at any time:

1. Press MENU, then select “Parental Fav’s & Setup”, then “Parental Controls”, then “Edit Settings.”
2. Scroll down to Passcode and press SELECT.
3. Enter your old passcode, then enter a new one twice to confirm.

**Note:** If you forget your passcode, call 1-800-531-5000 to reset it. You must be the registered account holder and have your account number.





## ● Unlock Your Receiver

When parental controls are locked, a message appears if you try to tune to a restricted program explaining why the program is blocked. To temporarily unlock a particular program select "Unlock Now" and enter your passcode.

For more unlock options, press MENU, select "Parental Fav's & Setup", then select "Parental Controls." Various options for removing restrictions temporarily or permanently will appear. Select one and enter your passcode.

**Note:** If you have Parental Controls set and temporarily unlocked, turning the receiver off will turn the parental controls back on.

## ● Rating Limits (or Ratings)

Set rating limits for Movies, TV and Other (unrated) shows. From the left menu, select "Rating Limits" then select either "Movies", "TV" or "Other".

**Note:** On Standard-Definition Receivers, select "Ratings" and then highlight the desired tab using the GREEN and RED buttons on your remote to switch between tabs. There is a separate tab for Movies, TV and Other.

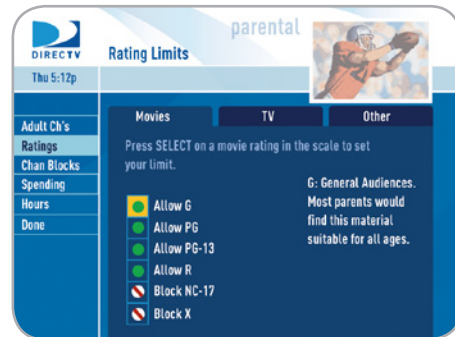

## -Movies

Select the button next to the overall rating limit you wish to impose. Brief descriptions of the ratings appear for your guidance.

## -TV Programs

Highlight and select the TV rating limit you desire. In addition to allowing or blocking shows by TV rating (i.e. TV\_MA) you can also set rating limits for particular types of content such as, Fantasy Violence (FV), Dialogue (D), Language (L), Sexual Content (S) and Violence (V). A description of each content type displays when highlighted.

## -Other Shows

Highlight and select the box to toggle the setting between "Allow No Rating" and "Block No Rating." If you choose "Block No Rating", programming that has no rating such as, news and sports will not display.

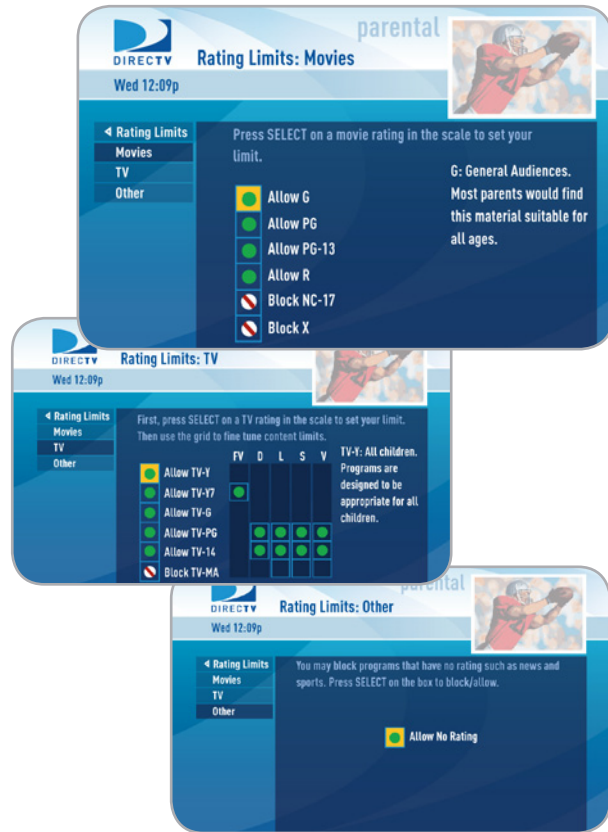

## ● Adult Channels

Hide adult channels in the program guide, Manage Recordings screens, and when channel surfing. Select "Adult Channels" (or "Adult Ch's" on Standard-Definition Receivers), then highlight and select the box to toggle between "Hide Adult" and "Show Adult".

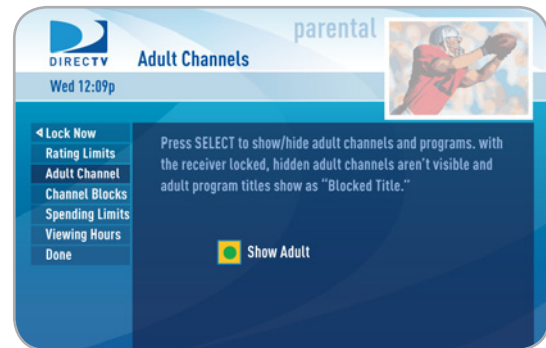

## ● Channel Blocks

Prevent children from viewing pre-selected channels. Select "Channel Blocks" (or "Chan Blocks" on Standard-Definition Receivers). Scroll down the channel list and select those you wish to block. You can also key in channel numbers for quicker access. Use "Block All" or "Allow All" to save time.

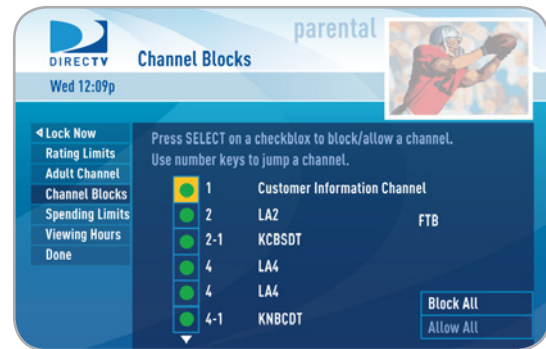

## ● Spending Limits

Limit the amount that can be spent on each Pay Per View purchase. Select "Spending Limits" (or "Spending" on Standard-Definition Receivers). Then enter your preferred spending dollar limit using the numbers on your remote.

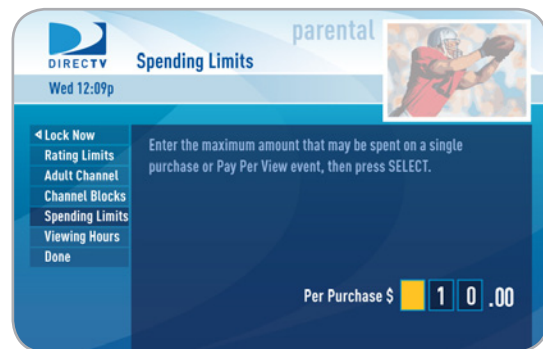

## ● Viewing Hours

Specify days and times when TV watching is allowed in your household. Select "Viewing Hours" (or "Hours" on Standard-Definition Receivers), then select the start times and durations for viewing. You can set hours based on "school nights" — Monday-Thursday — and/or weekend nights—Friday-Saturday, and Sunday.



## Favorite Channels

The Favorites feature lets you create lists of your favorite channels. If a favorites list is active, you'll see only those specific channels listed in the guide as well as, when you're channel surfing in live TV. You can create up to two custom lists on this receiver. You can also choose "Channels I Get" to see only the channels that are in your DIRECTV programming package.

Access the Favorites feature from the main menu, the guide, or live TV. From the main menu, select "Parental, Fav's & Setup," then "Favorite Channels." From live TV or the Guide, press the YELLOW button, then select "Change favorites list."

If you haven't created a Favorites list, the "Setup Custom 1" and "Setup Custom 2" options will be displayed. Select the one you want, and follow the on-screen instructions to create and name your list. Once your list is created, press the YELLOW button while in the guide or live TV, select "Change favorites list" and select the list you want to use.

Selecting a Favorites list makes it active and hides the display of all other channels in the guide. The name of the currently selected Favorites list is displayed in the bottom left of the program guide screen to remind you which list you are currently using. To return to displaying all channels, press the YELLOW button while in the guide or live TV, select "Change favorites list", and select "All Channels".

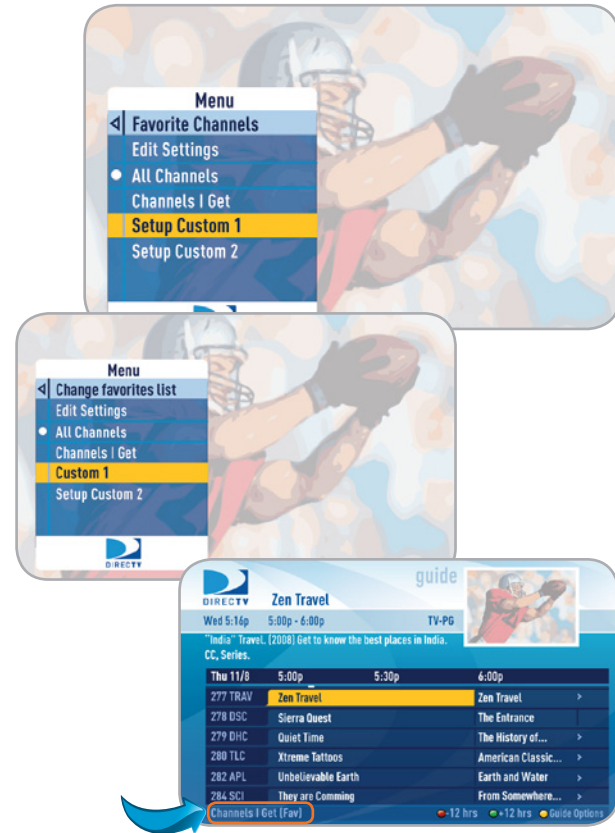

Chapter 1  
Chapter 2  
Chapter 3  
Chapter 4  
Chapter 5

## System Setup

Go to System Setup to review or change your system settings which include, audio options, video format, tv resolution, network setup, remote control setup and more. Press MENU, select "Parental, Fav's & Setup," then "System Setup."

### • Info & Test

Select "Info & Test" to display the System Info & Test screen.

Select "Run System Test" to initiate a test of the tuners, access card, receiver ID and phone line.

**Note:** Running the System Test will interfere with live TV and any current recordings.

Select "More System Info" to review your basic system information such as receiver model, receiver ID, access card number, software version etc... as well as, current receiver settings. This information can be useful during troubleshooting.

**Note:** For Standard-Definition Receivers select "Info & Test" and then press the GREEN and RED buttons on your remote to move between the System Info and System Test screens.

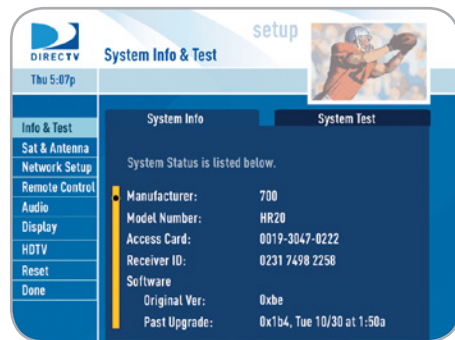

## ● Display

Select "Display" and then select either "Preferences", "Captioning" or "Clock".

**Note:** For Standard-Definition Receivers select "Display" and then press the GREEN and RED buttons on your remote to move between the Preferences, TV Ratio and Time Zone screens.

### -Preferences

These are user interface display settings which include:

- **Recording Tips (High-Definition Receivers ONLY):** Turn "On" or "Off" helpful tips that display on screen whenever you schedule a recording.
- **Guide HD Channels (High-Definition Receivers ONLY):** Choose whether you want the guide to show you HD channels and their duplicate SD channels or to hide the SD duplicates.
- **Guide shows:** Select whether you want the first press of the GUIDE button to take you directly to the program guide or to go to the category filter first. No matter which one you choose, pressing GUIDE a second time shows you the other option.

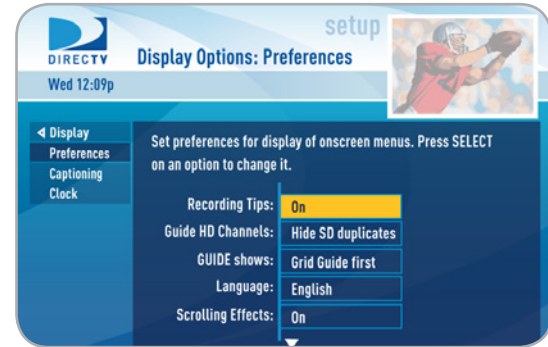

## Parental, Fav's & Setup - System Setup

- **Language:** Select your preferred on-screen text language.
- **Scrolling Effects:** Turn scrolling effects on or off. This affects the appearance of large text areas when they scroll.
- **Banner Time:** Set the channel banner time to determine how quickly the banner disappears after moving to a new channel.

### -Captioning

#### High-Definition Receivers

On High-Definition receivers, select "Captioning" to turn closed captioning on or off, and to select the font style, size and color for the display of captions.

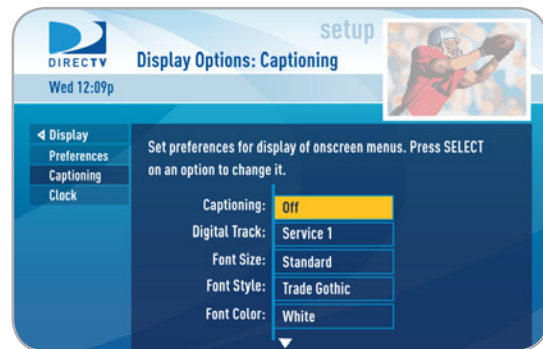



### -Clock

Select "Clock" (or "Time Zone" on Standard-Definition Receivers) to set your time zone and whether you want the receiver to show Daylight Savings time or not.

### • TV Ratio

On Standard-Definition Receivers, select the "TV Ratio" tab to set the "aspect ratio" of your TV. Most Standard-Definition TVs are 4:3. Most high-definition (HD) TVs are 16:9. This option is also available on High-Definition Receivers. Go to Chapter 2 - System Setup, HDTV for more information.

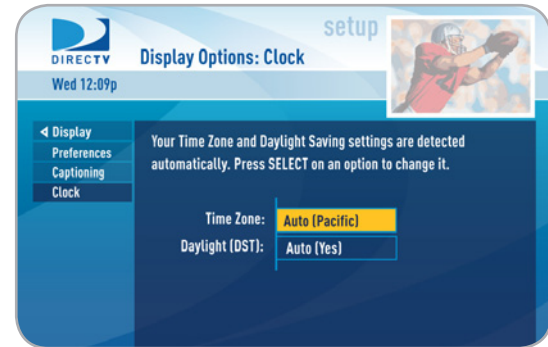

## ● Audio

Select "Audio" to make a persistent change to your audio settings.

**Note:** To change your preferred audio language temporarily, use the Audio Options item from the Options menu in Live TV, or press GREEN while watching live TV to cycle through the available audio tracks.

Audio options include:

- **Language:** Select your preferred audio language, i.e. English, Spanish, Chinese, etc...
- **Sound Effects:** Select the volume of sound effects
- **Dolby® Digital:** Select whether you want Dolby® Digital audio output on or off, i.e. for a surround sound system.

Not all TV programs deliver Dolby® Digital 5.1 audio. Look for the Dolby® Digital icon in the program description and Channel Banner.

HD Channels include 5.1 surround sound when available from the programmer. Additional equipment is required and sold separately. "Dolby" and the double-D symbol are trademarks of Dolby Laboratories.

**Note:** For Standard-Definition Receivers select "Audio" and then press the GREEN and RED buttons on your remote to move between the Language, Sound Effects and Dolby® Digital screens.

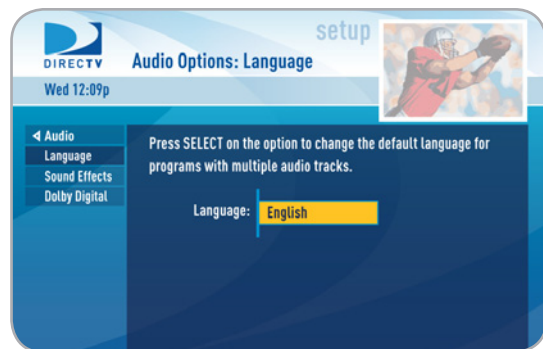

## ● HDTV



Select "HDTV" and then select either "Video", "TV Ratio" or "TV Resolution". Before you get started, you may want to review Appendix 3, About High-Definition, which describes HD formats and resolutions.

### -Video

Set your preference for the following screen options: Native, Screen Format and Bar Color.

- **Native:** You can turn Native mode ON or OFF. When Native Mode is ON, your TV auto-changes to match the resolution of the program coming into the receiver. For example, if Native mode is ON and a program is being broadcast in 480p, your High-Definition Receiver tells the TV to show it in that same format. If the next program changes to 1080i, the receiver tells the TV to change to that format. Native mode slows down the system's response time to channel changes since the receiver and TV must adjust the picture resolution at every channel change. Because of this, the default setting is OFF. When Native Mode is OFF, your receiver will display the program at the highest resolution set on the "TV Resolutions" screen.
- **Screen Format:** When a program is broadcast in a format that does not exactly fit your TV screen, your receiver will automatically size the picture. Screen Format options include Original Format, Pillar Box (Widescreen 16:9 HDTVs only), Letterbox (Standard 4:3 HDTVs only), Stretch and Crop.

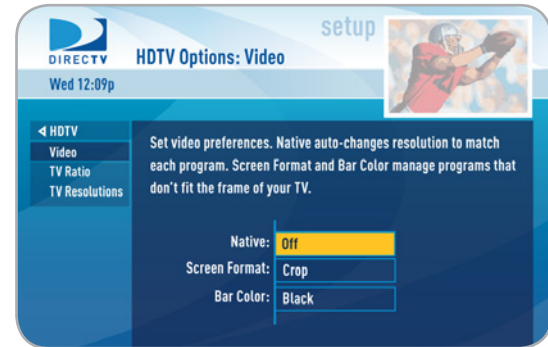

If you're watching a widescreen movie on a Standard 4:3 TV, you may want to choose "Letterbox" which places bars on the top and bottom of the screen. If your HDTV is 4:3 aspect ratio, you may want to "Crop" or cut off the content at the left and right side of the screen while preserving the proportion of the picture that remains. You can also "Stretch" the picture vertically or horizontally to fill up the screen.

- **Bar Color:** Select the Bar Color option to set the color of the bars displayed when you view programming in Letterbox or Pillar box modes.

## -TV Ratio

Set the aspect ratio that matches your TV. Options are Standard 4:3 or Widescreen 16:9.

## -TV Resolutions

Select the resolutions your TV can support so your receiver can pass the proper signal. To find the resolutions your TV supports, check the user's guide that came with your TV. If you select a resolution your TV doesn't support, the receiver will reset the setting after a few seconds.



## ● Network Setup

### High-Definition Receivers

Select "Network Setup" to setup and test the connection of your DVR to the Internet. See Appendix 2, "How to Network Your DVR" for details.

## ● Remote Control

When the MODE switch on your remote is in the left-most position, it controls your DIRECTV Receiver. However, you can also program the AV1, AV2 and TV positions to control other equipment such as your TV, DVD, VCR or Stereo.

**Note:** For Standard-Definition Receivers, select "Remote" and then select either "Program Remote", "IR/RF Setup", or "Receiver Mode".

### -Program Remote

Follow the step by step instructions to set your remote to control your TV or other A/V equipment such as, a DVD player or surround sound system. For best results, it is helpful to know the model number and brand of your equipment.

This is also where you'll have the option to "Reset Remote" which clears the AV1, AV2 and TV modes.



### -IR/RF Setup

Certain remote control models feature RF (radio frequency) capability. Refer to the model number printed on the top left corner of your DIRECTV Remote Control. Look for the letter(s) "R" or "RB" at the end of the model number which indicates that the remote supports radio frequency.

If you have a remote with RF capability you can change the remote's signal from Infrared (IR) to RF. While the IR signal requires a clear line of sight to the front of the receiver, RF signals let you put your receiver inside a cabinet or behind solid doors and still be able to command it from up to 200 feet away.

**Note:** Not all DIRECTV Receivers are RF-capable.

### -Receiver Mode

Select "Receiver Mode" if you want to use one remote to command a second DIRECTV® Receiver.

### -Advanced Setups

Use this option to setup your remote to control 3 or more receivers in one room.

## ● Satellite (or Sat & Antenna)

This option is used by installers when your system is initially set up; you should not have to use it. However, you can use this screen to view the satellite signal strength your receiver is getting or to repeat the satellite setup procedure.

### High-Definition Receivers

On High-Definition Receivers, the “Antenna Setup” option can be used to display channels received via your off-air antenna in the Guide. You must have an off-air (terrestrial) antenna connected to your HD DVR Receiver. Not all HD DVR’s have a built-in off-air tuner.

## ● Whole-Home

### High-Definition Receivers

If you’re using DIRECTV® Whole-Home DVR service you can use this option to set or change your DVR Playlist Sharing preferences or to create or change the names of each receiver location. To learn more, read the “DIRECTV® Whole-Home DVR service” section in Chapter 2.



### ● Reset

The Reset screen lets you restart the receiver, reset to factory defaults, or reset everything.

- “Restart Receiver” is the same function as pressing the red reset button behind the access card door on the front of the receiver. This option does not affect your settings and scheduled recordings.
- “Reset Defaults” erases all of your personal preference items, such as parental controls, favorites, language and scheduled recordings, and restores the receiver configuration to how it was set at the factory.
- “Reset Everything”: Completely erases everything from system memory and starts over like a new receiver, starting over with Guided Setup.

**WARNING:**

All your recordings will be erased from the hard drive!

**Note:** If Parental Controls are locked, you must enter your password to reset the receiver.

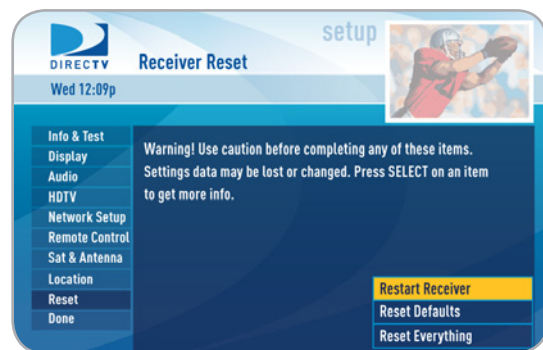



- Access Card

## Standard-Definition Receivers

Do not select Access Card unless you have a new access card provided by DIRECTV. DIRECTV will provide new access cards and instructions when necessary. Follow the on-screen directions to replace your access card. You will need your old and new access cards to complete this process.

## Help Topics and FAQs

For helpful information about your receiver as well as, frequently asked questions (FAQs), press MENU, select "Parental, Fav's & Setup" and then select "Help". Select a folder to open it, and then select a topic of your choice. Press the GREEN button to go to the FAQ tab.

**Note:** On Standard-Definition Receivers, press MENU, select "Customer Care & Help" and then select "Help Topics".



## CHAPTER 3 - CONNECTIONS FOR TV AND AUXILIARY EQUIPMENT

---

● CONNECTIONS .....	100
● SETUP AND ACTIVATION .....	104

## Connections

For the best user experience and system performance we highly recommend that your system be professionally installed. Call 1-800-531-5000 to schedule an installation.

### Your Phone Connection

Connecting your receiver to a land-based telephone line saves you money because it allows you to purchase DIRECTV Cinema™ movies and Pay-Per-View events without calling DIRECTV to order. It is required for sports package subscriptions and is also used to enhance the interactive features available on our interactive channels. The receiver uses a toll-free number once a month for a few minutes and is designed not to interfere with your regular phone service. You will need an RJ11-type modulator jack (the most common type of phone jack). If you disconnect the phone line, the receiver will not allow you to purchase PPV programs and some features of our interactive channels will be limited. **Do not connect your receiver to a digital PBX phone system — doing so may permanently damage your equipment and void your warranty.**

### Connections for Auxiliary Equipment

The following instructions apply if you are upgrading to a new TV or adding a surround sound system, DVD player/burner or VCR some time after your professional installation. Due to restrictions imposed by copyright holders, certain programming may include content protection measures that may restrict viewing or recording with certain consumer electronics equipment attached to the receiver. Please contact the manufacturer of such equipment for additional information.

Not all cables come with your digital satellite receiver; you may need to purchase additional cables depending on your setup.

**Note:** Never connect an IN to an IN or an OUT to an OUT. All A/V jacks and inputs are color coded. Always match the color of the plug to the same color of the jack.

**Tip:** To obtain the best picture quality, make sure the receiver is connected directly to the TV.

All of the video and audio outputs on your receiver offer good quality. Pick one of each from the list below, based on the connectors your TV supports; they are listed in order, with the highest quality options at the top of each list.

## Video Connections

- HDMI [High-Definition Multimedia Interface, one connector per receiver] provides the best digital video and digital audio in one connector.
- Component Video Output (YPbPr, one set per receiver) provides high-quality video, but does not provide audio. You will need to connect audio separately using the digital audio or RCA audio connectors.
- S-video (one connector per receiver) provides good video, but does not provide audio. You will need to connect audio separately using the digital audio or RCA audio connectors.
- RCA jacks (two sets per receiver) provide good video and usually come bundled with three cables for one video and two audio channels.

## Audio Connections

- HDMI [High-Definition Multimedia Interface] provides the best digital video and audio in one connector.
- Digital Audio Optical (one connector per receiver) provides excellent quality digital audio and is often used on newer surround sound and DVD equipment.
- Digital Audio Coax (one connector per receiver) provides high quality digital audio and is also found on newer surround sound and DVD equipment.
- RCA jacks provide good audio quality and are found on older auxiliary equipment.
- There are so many makes and models of TVs and auxiliary equipment, it is impossible to fully describe all of the possible connections between them and your receiver. Refer to the manuals for that equipment to see the connection options specific to each make and model. The following images show examples of how your receiver may be connected, using the supported video and audio connections for the TV, the surround sound, and the DVD player/burner or VCR.

### WARNING:

Do not connect your receiver (or any other equipment such as a TV or VCR) to the AC power supply until you have properly connected all the other cables.

## Example: TV with HDMI Connector

Here is an example using a TV that has an HDMI connector as the best video/audio input and a surround sound system that has a digital audio optical connector as the best audio input:

This example also shows using a VCR or DVD burner with RCA audio and video connectors.

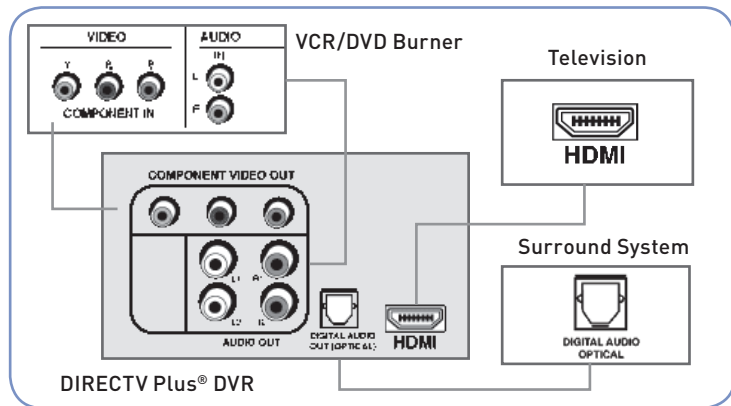

## Example: TV with Component Video Connectors

Here is an example using a TV that has component video connectors as the best video input with RCA audio connectors as the best audio input and a surround sound system that has a digital audio coax connector as the best audio input:

This example also shows using a VCR or DVD burner with RCA audio and video connectors.

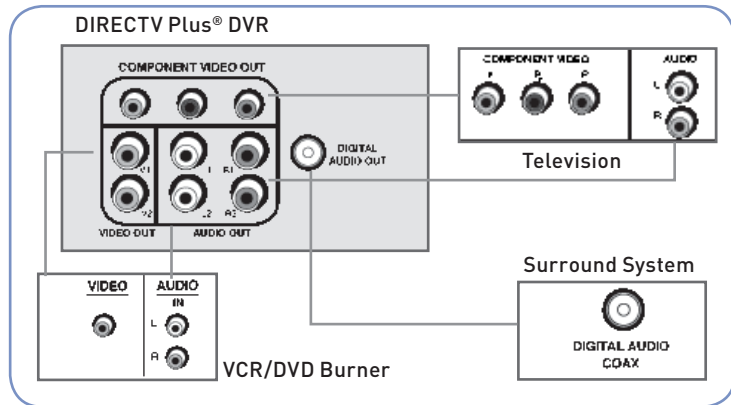

## Example: TV with S-Video Connector

Here is an example of a TV that has an S-video connector as the best video input and RCA audio connectors as the best audio input and a surround sound system with a digital audio optical connector as the best audio input:

This example also shows using a VCR or DVD burner with RCA audio and video connectors.

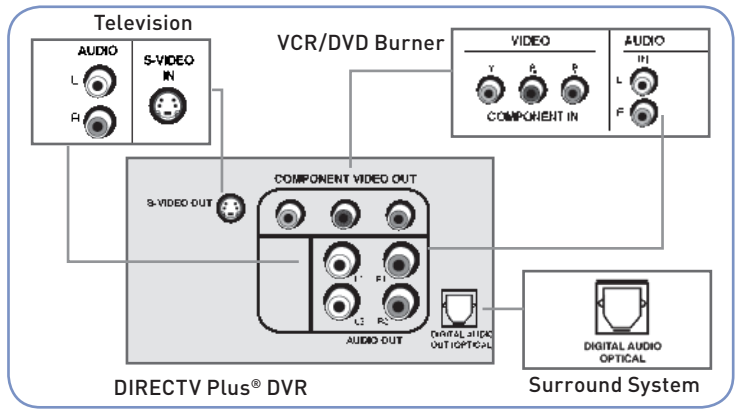

## Example: TV with RCA Connectors

Here is an example of a TV that has RCA connectors as the best audio/video inputs and a surround sound system with a digital audio coax connector as the best audio input:

This example also shows using a VCR or DVD burner with RCA audio and video connectors.

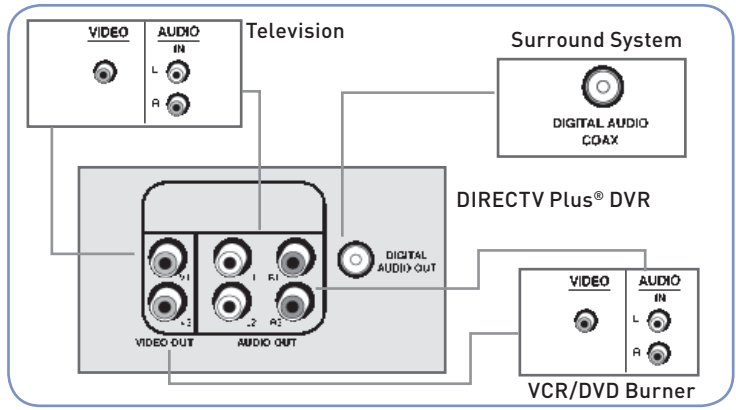

## Guided Setup

If your receiver was not professionally installed, or you have had to reset your receiver for any reason, you will need to follow the guided setup screens before starting DIRECTV Service.

1. Make sure the MODE switch at the top of the remote control is set to DIRECTV, which is the far-left position.
2. Press PWR. The DIRECTV Plus® DVR will turn on. (Make sure your TV is also turned on!)
3. The first screen will allow you to select a language. Using the arrow keys on the remote control, move to the language you prefer and press SELECT.
4. Follow the on-screen instructions.

After these setup procedures are complete, you'll see a message on-screen that says, "Acquiring Satellite Info," as the receiver gathers information from the satellite for the on-screen program guide.

Next, you'll be given the opportunity to program your remote to control other equipment such as your TV and/or DVD player. Just follow the screen instructions and you'll be ready to watch in no time!

## Activate Your DIRECTV® Service

Once all the setup processes are complete, all that's left to do is activate your DIRECTV Service. Before you make the call, be sure to: Have on hand your service address, social security number and a valid major credit card.

Note your receiver ID and access card numbers. The receiver ID is on a sticker behind the access card door on the front of the receiver, while the card number is on the access card itself. Use the Product Information page following the Table of Contents to note this information.

When you're ready, just call 1-800-531-5000; pick the programming package that's right for you and subscribe to DIRECTV service.



## CHAPTER 4 - TROUBLESHOOTING

---

- TROUBLESHOOTING TIPS .....106
- DIRECTV® RECEIVER OR TV PROBLEMS .....108
- RECORDED TV TROUBLESHOOTING .....116
- REMOTE CONTROL PROBLEMS .....120
- RUNNING THE SYSTEM TEST .....121

### Resetting / Reauthorizing Your Receiver

Many problems can be corrected by performing a simple reset of the DIRECTV® Plus DVR. If you experience frozen audio or video, blank screen, or the system won't respond to front panel button or remote control, try one of these:

- Press the red RESET button behind the access card panel door on the front of the DIRECTV® Receiver, then wait for program guide information to be acquired.
- If the problems persist, try unplugging the power cord of the DIRECTV Plus® DVR for 15 seconds, then plug it in again.
- If the above two items don't work, try reauthorizing your receiver. On a computer, go to [directv.com/reauthorize](http://directv.com/reauthorize) and follow the onscreen instructions. You will need to be logged into your account on [directv.com](http://directv.com) to complete this process.
- Running the System Test (at the end of this section) can also help you diagnose and solve many common problems.

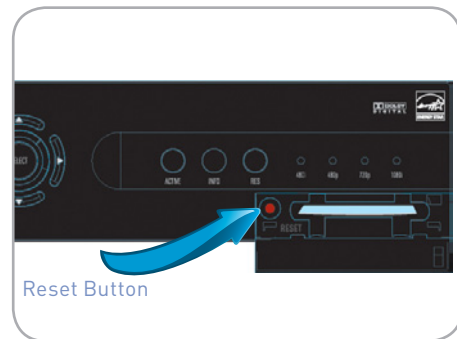

### System Software Updates

DIRECTV periodically sends system software updates to your receiver to improve performance and upgrade features and functions. These updates will occur automatically, usually at times when the receiver would likely be turned off. If your receiver is on when an update is sent, you will see an on-screen message and you may experience a disruption in reception for a few minutes. Your reception should return to normal after the update is complete. Your receiver must be plugged in to AC power to receive any updates.

## On-Screen Error Messages

There may be times when you see an on-screen message similar to the one on the right. The top line of the message gives a brief description of what causes the on-screen message to display, while the second line displays instructions to follow. Most on-screen messages supply an error code in parentheses, go to [directv.com/troubleshooting](http://directv.com/troubleshooting) and select the on-screen error message for solutions.

The message at right shows an example of trying to view a channel that you have not purchased or that is not in your programming package. To resolve this error, call Customer Service at 1-800-531-5000 and mention the error code number when prompted.

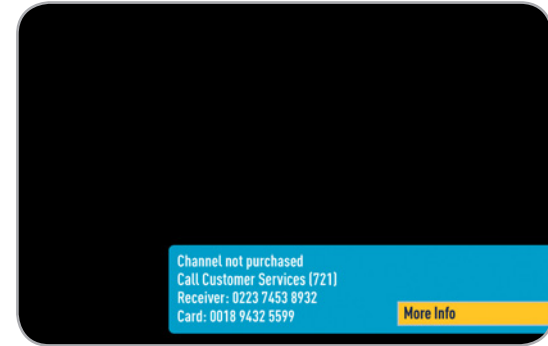

### Problem: Progress bar freezes while Acquiring Guide Data / Data From Satellite

While the “Acquiring Guide Data” or “Acquiring Data From Satellite” message is on the screen, progress freezes during download.

#### Possible Causes:

- This may be normal. After five minutes, the screen saver will display. Press any key on the remote to see the progress bar again.
- May happen if your satellite dish isn't adjusted properly.

#### Solution:

- If satellite data acquisition still does not move forward, press the RESET button behind the access panel door on the front of the DIRECTV Plus® DVR and wait for program guide information to be acquired.

### Problem: Wrong picture, blue screen, snow or black/blank picture

Your TV displays incorrect picture, or you have a blue, black, snowy or blank screen.

#### Possible Causes:

- The DIRECTV Plus® DVR and most TVs and VCRs let you toggle between different video sources.
- Your TV may be on a different input source than what you are trying to view.

#### Solution:

- If you don't see the signal you think you should be seeing, try using these buttons to toggle between the signals:
  - Press the TV/VCR button on the VCR remote or on the VCR's front panel.
  - Press the INPUT button on the TV remote control to change video source.
- If problems persist, turn off all equipment that is connected to your TV, wait a few minutes, then turn the DIRECTV Plus® DVR back on.
- Check your connections and cables.

**Problem: DIRECTV Plus® DVR will not turn on**

Your receiver won't turn on with either the remote or from the front panel.

**Possible Causes:**

- Remote batteries are dead.
- Receiver or power strip is not plugged in to a power source, or power cord is not plugged in to receiver.
- Wall outlet is dead.

**Solution:**

- Make sure the remote control MODE switch is in the left-most position (DIRECTV mode), and press PWR (power key) or press POWER button on the front panel of the receiver.
- Verify that the power cord is plugged into the DIRECTV Plus® DVR and the wall outlet.
- Check the outlet or power strip to make sure it is "live" by plugging in something else.
- Replace batteries in remote control.
- Be sure remote is pointed at remote sensor on receiver, and sensor is not blocked.
- Try plugging receiver into a different wall outlet.
- Unplug receiver for five minutes, and then plug it in again.
- Press TV POWER ON. Press it again, if needed.
- If your receiver is plugged into a power strip, check the power strip and reset its circuit breaker, if needed.

### Problem: DIRECTV Plus® DVR Turns off while playing

Your receiver turns off unexpectedly.

#### Possible Causes:

- Excessive heat may have caused the receiver to go into a standby state.
- Electronic protection circuit may have been activated due to a power surge.
- You may have blown a circuit breaker or be experiencing a power outage.
- Parental viewing limits may have been activated on your DIRECTV® Receiver.

#### Solution:

- Ensure that your receiver has plenty of ventilation and that nothing is on top of the receiver.
- Wait 30 seconds for internal circuits to reset, then turn receiver back on.
- Check the circuit breakers in your home.
- Consider using a line conditioner or surge protector.
- Consult an electrician if the problem is frequent or severe, especially if other household appliances or electronics are affected.
- If parental limits are active, turn your DIRECTV® Receiver back on and enter your parental lock code at the prompt.

### Problem: DIRECTV Plus® DVR turns on or changes channels unexpectedly

Your receiver changes to a different channel without a remote control command.

#### Possible Causes:

- A scheduled recording may be about to begin, so the receiver is changing channels to record the show as requested.
- Your TV's timer may have been activated.

**Solution:**

- Check your To Do List to see if there are other scheduled recordings. (Press MENU, select “Manage Recordings”, then “To Do list.”)
- Check your TV owner’s manual to turn off the TV’s timer.

**Problem: Blank screen**

There is nothing on your TV screen.

**Possible Causes:**

- Your TV and/or your receiver are not powered on.
- Your receiver may be hooked up to the TV incorrectly.
- You may be on the wrong video source for your DIRECTV® Receiver.
- You may be tuned to a channel that is not currently broadcasting, or that you don’t subscribe to.

**Solution:**

- Check that DIRECTV Plus® DVR and TV are both powered on.
- Read Chapter 3, “Connections for TV and Auxiliary Equipment” for instructions about connecting your receiver.
- Press the INPUT button on the TV remote control to change video source.
- Try another channel and see if you have live video.
- Press the POWER button on the front panel of the DIRECTV® Receiver.
- Press the red RESET button behind the door on the front panel of the receiver.

### **Problem: Temporary loss of the satellite signal (“Searching for Satellite Signal” message is displayed), “frozen” picture, or picture breaks into blocks / pixels**

The image on your screen is frozen, blocky, or you see a message that says, “Searching for Satellite Signal (x 771).

#### **Possible Causes:**

- Severe weather (rain, snow, hail etc.) may cause this issue.
- There may be an obstruction to your dish (debris, snow, ice, etc.) or a building or tree that blocks your line of sight to the satellite.
- There may be a problem with the cables running from your satellite dish to your DIRECTV® Receiver.
- If the picture is frozen, blocky, or pixels, there may be a problem with the transmission from the source.

#### **Solution:**

- Weather issues are usually temporary. Wait for the weather to clear and your signal should return to normal.
- If there are no weather problems in your area, reset your DIRECTV Plus® DVR using the red RESET button behind the door on the front of the receiver or by unplugging the receiver for 15 seconds and then plugging it back in.
- You can also check all the cable connections between your DIRECTV Plus® DVR and the satellite dish for loose or broken connections.
- If the problem is coming from the program source (for example, you see the problem on one channel, but not on any others), wait for the broadcasting channel to resolve the issue.
- If there are obstructions blocking the dish’s clear view of the satellite, you should contact a professional to remove them or a DIRECTV installer at 1-800-531-5000 to relocate your dish.
- If your signal strength is lower than 70 (60 or lower on HD receivers) on most transponders in good weather, contact a professional installer to realign your dish or call us at 1-800-531-5000.



**Problem: Partial programming loss. Channels missing from the Guide. Channel is in the Guide but I can't tune to it.**

Your Program Guide is missing channels, or you are unable to use the guide to tune to a channel.

**Possible Causes:**

- The channels might be excluded from the Favorites list currently in use.
- Your satellite dish may be incorrectly configured.
- Your receiver information may need to be refreshed.

**Solution:**

- To change your Favorites List, press GUIDE on the remote, then press the YELLOW button and select "Change Favorites List", then "All Channels."
- Enter the channel number using the number pad on the remote control.
- Check the dish type set in your receiver's preferences: Press MENU, then select "Parental, Fav's & Setup," "System Setup," "Info & Test" then "More System Info." (On Standard-Definition Receivers press MENU, select "Parental, Fav's & Setup" and then "System Setup.") Check the Satellite Dish Type shown on the System Setup screen to see if it is correct. If not, select "Satellite" from the left menu, then select "Repeat Satellite Setup." Follow the steps. From the Satellite Dish Type screen, make sure the proper dish type is selected.
- To refresh your receiver information, go to [directv.com/reauthorize](http://directv.com/reauthorize). You will need to be logged into your account on [directv.com](http://directv.com) to complete this process.

### Problem: My video and audio are out of sync.

The audio track does not match the lip movements on the screen.

#### Possible Causes:

- Problem with how the program was produced or how it was sent to DIRECTV for broadcast.
- Your surround sound system may be out of sync, or may be set up incorrectly.

#### Solution:

- Change the channel on your DIRECTV® Receiver. This may re-sync the audio.
- Rewind the program for about 5 seconds, then fast forward to live programming.
- Try replacing the cables between your surround sound system and your DIRECTV Receiver. Refer to your surround sound system's manual for assistance.
- If the issue continues, reset your DIRECTV Receiver. Press the RESET button behind the access panel door on the front of the DIRECTV Receiver. You can also press MENU, press SELECT "Parental, Fav's & Setup", then select "System Setup." Select the "Reset" item from the left menu and follow the on-screen instructions.

### Problem: No Audio with Picture

You can see a picture from your DIRECTV® Receiver, but there is no sound.

#### Possible Causes:

- A setting (such as mute or volume) may have changed on the receiver or your TV.
- The cables between your TV and the receiver may not be connected properly, or there may be a problem with an external stereo or surround sound system.
- Verify that your surround sound system is working, if applicable.

**Solution:**

- Verify “MUTE” button not activated.
- Raise or lower the volume. Did volume meter display on TV?
- Test sound on TV by changing the input to another source, such as a DVD player, game box, or antenna.
- If connected to stereo, make sure stereo is on and set to the correct mode.
- Verify audio cables are secure and connected correctly.
- Verify that your surround sound system is working, if applicable.
- If the issue continues, reset your DIRECTV® Receiver. Press the RESET button behind the access panel door on the front of the DIRECTV® Receiver. You can also press MENU, select “Parental, Fav’s & Setup”, then select “System Setup.” Select the “Reset” item from the left menu and follow the on-screen instructions.

**Problem: Caller ID not working**

Caller ID information isn’t showing on your TV screen when phone calls come in.

**Possible Causes:**

- You don’t subscribe to Caller ID service through your local phone company.
- The Caller ID feature in your DIRECTV® Receiver is turned off. See “Caller ID” in Chapter 2.
- You are using a wireless phone jack, which usually will not transmit Caller ID information.

**Solution:**

- Contact your local phone company to subscribe to Caller ID service.
- Select “Caller ID & Messages” from the main menu to turn on your Caller ID notifications.
- Verify that your wireless phone jack transmits Caller ID information. If not, connect a standard phone cable to your receiver or replace your wireless phone jack.

### Problem: A program I tried to record does not show up in the My Playlist screen.

You wanted to record a program to watch later, but it is not listed in your Playlist.

#### Possible Causes:

- Someone else may have prevented the recording or erased the program after it recorded.
- The recording may have been cancelled due to a conflict with another program with higher priority in the Prioritizer.
- The program may have been blocked by Parental Locks.
- You may have deleted a Series recording. If you delete a Series by pressing RECORD on an episode in the Guide, you cancel the entire series, not just the highlighted episode.

#### Solution:

- To see if the program was recorded then deleted, press MENU, select "Manage Recordings", then in the left menu, select "History."
- If the recording was cancelled due to a Prioritizer conflict, you will need to record the program again and if necessary you will need to adjust the programming priority. See "Main Menu, Series Manager (or Prioritizer)" section in chapter 2 for details.
- Check the Parental Locks on your receiver and TV. Adjust the content ratings, if necessary.

### Problem: I wanted to record a program, but I got an error message saying it conflicted with another scheduled record. What do I do?

Your DIRECTV Plus® DVR can record up to two programs at once, or it can record one program while you watch another live program.

#### Possible Causes:

- You tried to record three programs at the same time or tried to watch a live program while recording two others at the same time.
- There was an overlap in the programs you tried to record.

**Solution:**

- If you tried to record three programs at once, or watch a live TV program with two others recording, you will need to decide which recording to cancel.
- If the overlap is a couple of minutes (for example, some networks occasionally start programs at 8:59 instead of 9:00 p.m.), adjust your recording start and end times in the Recording Options. See Chapter 1, “Finding and Recording Programs.”

**Problem:** I recorded a program, and the recording got cut off just before the end, so I missed the last bit of the program.

Your recording stopped before the program or event ended.

**Possible Causes:**

- The program you were trying to record may have started or ended early.
- If you were trying to record a sporting event, the event may have run over its allotted time.
- You may have had a recording conflict with a higher priority program.
- Someone may have manually ended the recording.

**Solution:**

- Try setting the end time of the recording in the Record Options so the recording ends one or two minutes later (or more, if necessary). You may be able to record the same program again later in the week. Check the Program Guide for additional showings.
- For sporting events, you may want to extend the recording stop time 15 minutes or more to protect against overtime games.
- If you had a priority conflict, try adjusting your start and end times. You may need to choose a different time slot to record a program if the conflict continues.

**Problem:** A program I recorded was displayed in the My Playlist screen, but got deleted before I could watch it.

Your recording(s) were deleted before you had a chance to view them.

### Possible Causes:

- Someone else manually deleted the program.
- The hard drive on your DVR is full. The program may not have recorded.
- The receiver may have deleted older recordings to make room for newer ones.
- You exceeded the allotted purchase or viewing time on a Pay Per View movie or event.

### Solution:

- Delete some of the content on your DVR to make room for new recordings.
- Change your recording options to keep programs until you delete them manually. See "Recording a single show" in chapter 1 for details (note the same process applies if you are setting up a series recording).
- You can also change a recording you've already made to "Keep Until I Delete." See "Managing My Playlist" in Chapter 2.
- To avoid this in the future, you can change settings for recordings that you've set to occur in the future, but haven't recorded yet. Press MENU, select "Manage Recordings", then "To Do List", choose the show you want to change and select it, select RECORD, press SELECT on "Keep...", press SELECT on the "Keep Until" box to change it to "I Delete", use the ARROW button to move over to Update and press SELECT.
- If you recorded a DIRECTV Cinema™ movie or Pay Per View event, but did not watch it, the time which you are allowed to purchase or watch it may have expired. To avoid this in the future, check your Pay Per View recordings in the My Playlist screen for expiration dates.

**Problem:** I've set up a series recording, but now I get a bunch of reruns and multiple copies of the same program.

Your DVR is getting full of duplicate recordings of the same program, or old episodes of the chosen show.

**Possible Causes:**

- Your series is set to record both First Run and Repeat episodes.

**Solution:**

- When you set up a series, make sure you select only the First Run option. This is the default for one-touch recording unless you have changed your default recording settings.

## Problem: My remote control doesn't work

### Possible Causes:

- Weak batteries are almost always the problem.
- Trying to operate equipment other than your DIRECTV Receiver?
- Remote sensor on the receiver could be blocked.

### Solution:

- Check that nothing is between the remote control and the remote sensor.
- Make sure the remote control is in DIRECTV mode. Slide the MODE switch on the remote to the DIRECTV position so the remote will control the DIRECTV® Receiver.
- Check the batteries in the remote control. They may be weak, dead or installed incorrectly. Try replacing batteries.
- If you're entering a channel number that is less than four digits long, the receiver might wait two seconds before tuning to the channel. Press ENTER after entering a channel number to tune immediately.
- If you are trying to operate a device other than the DIRECTV Plus® DVR that you have programmed the remote to control, make sure you first slide the MODE switch to the mode that is programmed for that device (AV1 or AV2). The indicator light for the component you're trying to control should light up when you press a valid key for that component. If it doesn't, make sure the MODE switch is in the correct position.
- Make sure the device you are trying to control has been programmed to your DIRECTV Remote Control. See Chapter 2, System Setup - Remote Control for instructions on how to program your remote to control other devices.
- If the indicator lights on the remote control start flashing, the batteries in the remote control are running low and should be replaced soon. You may also see an on-screen message that the batteries are low. Note that when you replace the batteries, you should not have to reprogram your remote to control other devices unless the batteries have been completely dead for a month or more.



The System Test allows you to run a basic diagnostics check on your DIRECTV Plus® DVR. If you are experiencing any trouble with your receiver, run the system test. It will also allow you to get your access card and receiver ID numbers or to initiate diagnostic procedures on your digital satellite receiver.

First make sure that:

- All connections — jacks, cables, etc. — are in place correctly (see Chapter 3, Connection for TV and Auxiliary Equipment, for more information).
- There are batteries in the remote control, and they are working correctly.
- The access card is inserted in the DIRECTV Receiver.

Follow these steps to run the diagnostics system test on your DIRECTV Plus® DVR.

1. Turn on your TV and the DIRECTV Plus® DVR.
2. Slide the mode switch to the DIRECTV position to put the remote control in satellite receiver-controlling mode, then press MENU to display the Quick Menu.
3. Select "Parental, Fav's & Setup."
4. Select "System Setup," then "Info & Test."
5. If you have a high-definition receiver, press SELECT on "Run System Test." If you have a Standard-Definition receiver, press the GREEN button to access the System Test tab and then press SELECT on "Run Test."
6. If your system does not pass the System Test, check any of these potential trouble areas: cabling, pointing the satellite dish, phone connection and access card.
7. If you continue to have problems, call DIRECTV Customer Service at 1-800-531-5000.
8. You should run a system test several times before concluding that there is a problem. Occasional fluctuations in the phone line or satellite signal can give temporary false readings.



## **CHAPTER 5 - WARRANTY AND OTHER INFORMATION**

---

- LIMITED 90-DAY WARRANTY .....124
- DIRECTV PROTECTION PLAN .....127
- FCC CUSTOMER INFORMATION .....129
- TERMS & CONDITIONS FOR USE OF SOFTWARE .....133

## Limited 90-Day Warranty

DIRECTV warrants your DIRECTV Plus® DVR (Model Number: R16, R22) or DIRECTV Plus® HD DVR (Model Number: HR20, HR21, HR22, HR23, HR24) and any included accessories against defects in material or workmanship for a period of ninety (90) days after the date of acquisition.

### Who is Covered?

You must have proof of acquisition to receive warranty service. A receipt or other document showing that you acquired the product is considered proof of acquisition. THIS LIMITED WARRANTY EXTENDS ONLY TO THE ORIGINAL CONSUMER ACQUIRER OR ANY PERSON RECEIVING THE DIRECTV PLUS® DVR AS A GIFT FROM THE ORIGINAL CONSUMER ACQUIRER AND TO NO OTHER ACQUIRER OR TRANSFEREE. THIS WARRANTY DOES NOT EXTEND TO COMMERCIAL USERS. THIS PRODUCT IS NOT AUTHORIZED FOR USE OUTSIDE THE UNITED STATES AND ANY SUCH USE VOIDS THIS WARRANTY.

### What is Covered?

Warranty coverage begins the day you acquire the product. For ninety (90) days from the acquisition date, at the option of DIRECTV, the DIRECTV Plus® DVR will be repaired or replaced with a new, repaired, refurbished or comparable product (whichever is deemed necessary) if it becomes defective or inoperative. This exchange is done without charge to you for parts and labor. You will be responsible for the cost of shipping to and from the location designated by DIRECTV. If DIRECTV cannot reasonably repair or replace the Receiver then DIRECTV may, at its sole discretion, refund the price you paid for the product or the current retail price of the product.

All products, including replacement products, are covered only for the original warranty period. When the warranty on the original product expires, the warranty on the replacement product also expires. After ninety (90) days from the date of acquisition, you pay for the replacement of all parts, and for all labor charges.

SOME STATES DO NOT ALLOW LIMITATIONS ON HOW LONG AN IMPLIED WARRANTY LASTS, SO THE ABOVE LIMITATION MAY NOT APPLY TO YOU.

## What is Excluded?

### Your warranty does NOT cover:

Labor charges for installation or setup of the product.

Installation, performance of, or repair of: audio/video cabling, telephone line, or accessory attachments used with the product.

Product replacement because of misuse, accident, lightning damage, unauthorized repair, or other cause not within the control of DIRECTV.

Incidental or consequential damages resulting from the product. SOME STATES DO NOT ALLOW THE EXCLUSION OF INCIDENTAL OR CONSEQUENTIAL DAMAGES, SO THE ABOVE EXCLUSION MAY NOT APPLY TO YOU.

Any modifications or other changes to the product, including but not limited to software or hardware modification in any way other than as expressly authorized by DIRECTV will void this limited warranty. Except in the case of hardware or software provided by DIRECTV, installing software modifications, "hacks" or utilizing service access or "back doors" will void this limited warranty.

Reception transmission problems caused by signal conditions, telephone line, or cable or antenna systems outside the unit.

A product that has been modified or adapted to enable it to operate in any country other than the country for which it was designed, manufactured, approved and/or authorized, or repair of products damaged by these modifications.

A product used for commercial or institutional purposes.

DIRECTV makes no warranty that the access connection will be a local (not long distance) phone call.

The continued provisioning of any of the programming and other services delivered through the Receiver including but not limited to television programming, show information, program guide data, and scheduling information.

## Make Sure You Keep...

Please keep your receipt or other document showing proof of acquisition. Attach it to this User Guide (see page 10) and keep both nearby. Also keep the original box and packing material in case you need to return your product.

## Before Requesting Repair Service...

Please check the troubleshooting section of this guide. This may save you a call to DIRECTV Customer Care.

### To Get Warranty Service...

Warranty service will be provided by DIRECTV. If you believe you need service for your Receiver, contact DIRECTV at 1-800-DIRECTV. A representative will go through a diagnostic checklist with you. If it is determined that the product needs to be returned for service or exchanged, you will receive a return authorization number. The representative will give you complete shipping details.

### To Get Out-of-Warranty Service...

To obtain out-of-warranty service contact DIRECTV at 1-800-DIRECTV for information on the possibility of and any costs for repair or replacement of out-of-warranty products.

ALL WARRANTIES IMPLIED BY LAW, INCLUDING ANY IMPLIED WARRANTIES OF MERCHANTABILITY AND FITNESS FOR A PARTICULAR PURPOSE ARE EXPRESSLY LIMITED TO THE DURATION OF THIS EXPRESS LIMITED WARRANTY.

WITH THE EXCEPTION OF ANY WARRANTIES IMPLIED BY THE LAW OF ANY STATE OF THE U.S.A., THIS EXPRESS LIMITED WARRANTY IS EXCLUSIVE AND IN LIEU OF ALL OTHER WARRANTIES, GUARANTEES, AGREEMENTS AND SIMILAR OBLIGATIONS OF DIRECTV. REPAIR OR REPLACEMENT AS PROVIDED IN THIS LIMITED WARRANTY IS THE EXCLUSIVE REMEDY UNDER THIS LIMITED WARRANTY. IN NO EVENT WILL DIRECTV BE LIABLE FOR ANY AMOUNT GREATER THAN THE RETAIL PRICE OF THE DIRECTV® Receiver. DIRECTV SHALL NOT BE LIABLE FOR ANY INCIDENTAL OR CONSEQUENTIAL DAMAGES FOR BREACH OF ANY EXPRESS OR IMPLIED WARRANTY ON THE DIRECTV® Receiver.

SOME STATES DO NOT ALLOW LIMITATIONS ON WARRANTIES, SO THE ABOVE LIMITATIONS MAY NOT APPLY TO YOU. THIS WARRANTY GIVES YOU SPECIFIC LEGAL RIGHTS. YOU MAY HAVE OTHER RIGHTS WHICH VARY FROM STATE TO STATE.

DIRECTV, Inc.  
2230 E. Imperial Hwy  
El Segundo, CA 90245  
1-800-DIRECTV

Safeguard your DIRECTV® System with the ultimate in professional technical service. For a low monthly fee, the DIRECTV PROTECTION PLAN covers the components of your entire DIRECTV® System, giving you affordable peace of mind and comprehensive support to ensure that you and your family enjoy nonstop DIRECTV® entertainment.

### DIRECTV PROTECTION PLAN Benefits

Your DIRECTV Limited Warranty provides certain remedies for this receiver during the stated coverage term. The DIRECTV PROTECTION PLAN provides comprehensive coverage for your DIRECTV® System, including:

Professional In-home service calls when needed	Dedicated Technical Support 24-hour a day
Power surge related repairs including those caused by lightning	Unlimited dish antenna alignments
Cables, switches, and associated wiring throughout your home	Replacement of defective receiver equipment (if problem can not be resolved over the phone)*
Defective remote control replacements	All parts and labor for repair

**All this — for one low monthly fee — covers every DIRECTV component and receiver on your account.**

## DIRECTV PROTECTION PLAN

Sign up today for the **DIRECTV PROTECTION PLAN** by calling **1-800-DIRECTV**

The DIRECTV PROTECTION PLAN is offered by AIG Warranty Guard and underwritten by New Hampshire Insurance Company on behalf of DIRECTV where authorized by law. Certain limitations may apply. Pricing, terms and conditions of the DIRECTV PROTECTION PLAN are subject to change. Full terms and conditions will be mailed to you prior to service billing and are available at [directv.com/protection](http://directv.com/protection).



This device complies with Part 15 of the FCC Rules. Operation is subject to the following two conditions: (1) this device may not cause harmful interference, and (2) this device must accept any interference received, including interference that may cause undesired operation.

Responsible Party:

DIRECTV, Inc.

2230 E. Imperial Hwy

El Segundo, CA 90245

1-800-DIRECTV

- Trade Name: DIRECTV
- Type of Equipment: DIRECTV Satellite Receiver
- Model Number: R or HR

Federal Communications Commission (FCC): This equipment complies with both Part 15 and Part 68 of the FCC rules.

This equipment has been tested and found to comply with the limits of a Class B digital device, pursuant to part 15 of the FCC Rules.

These limits are designed to provide reasonable protection against harmful interference in a residential installation.

This equipment generates, uses, and can radiate radio frequency energy and, if not installed and used in accordance with the instructions, may cause harmful interference to radio communications. However there is no guarantee that interference will not occur in a particular installation. If this equipment does cause harmful interference to radio or television reception, which can be determined by removing and applying power to the equipment, the user is encouraged to try to correct the interference by one or more of the following measures:

- Reorient or relocate the receiving satellite dish antenna.
- Increase the separation between the equipment and the DIRECTV Receiver.
- Connect the equipment into an outlet on a circuit different from that to which the DIRECTV Receiver is connected.
- Consult the dealer or an experienced radio/TV technician for help.
- CAUTION: Changes or modifications not expressly approved by the manufacturer responsible for compliance could void the user's authority to operate the equipment.

The user may find the following booklet, prepared by the Federal communications Commission, helpful: "How to Identify and Resolve Radio and TV Interference Problems." This booklet is available from the U.S. Government Printing Office, Washington, DC. To meet FCC requirements, only peripherals (computer input/output devices, terminals, printers, etc.) certified to comply with Class B limits may be attached to this device. Operation with non-certified peripherals is likely to result in interference to radio and TV reception. To meet FCC requirements, shielded cables are required to connect the device to a personal computer, peripheral, or other Class B certified device. This equipment complies with Part 68 of the FCC Rules and the requirements adopted by ACTA. On the back of this equipment is a label that contains a product identifier in the format US:AAAEQ##TXXXX.

If requested, this information must be provided to your telephone company. This equipment uses the following USOC Jack: RJ11C. A plug and jack used to connect this equipment to the premises wiring and telephone network must comply with the applicable FCC Part 68 rules and requirements adopted by ACTA. A compliant telephone cord and modular plug is provided with this product. It is designed to be connected to a compatible modular jack that is also compliant.

See installation instructions for details.

The REN is used to determine the number of devices that may connect to a telephone line. Excessive RENs on a telephone line may result in the devices not ringing in response to an incoming call. In most but not all areas, the sum of the RENs should not exceed five (5.0).

To be certain of the number of devices that may be connected to a line, as determined by the total RENs, contact your local telephone company. The REN for this product is part of the product identifier that has the format US: AAAEQ##TXXXX. The digits represented by ## are the REN without the decimal point (e.g., 03 is a REN of 0.3).

If this DIRECTV® Receiver causes harm to the telephone network, the telephone company will notify you in advance that temporary discontinuance of service may be required. But if advance notice isn't practical, the telephone company will notify the customer as soon as possible. Also, you will be advised of your right to file a complaint with the FCC if you believe it is necessary.

The telephone company may make changes in its facilities, equipment, operations or procedures that could affect the proper functioning of your equipment. If they do, you will be notified in advance in order for you to make necessary modifications to maintain uninterrupted service. Connection to party line service is subject to state tariffs. Contact the state public utility commission, public service commission or corporation commission for information.

If trouble is experienced with this unit, for repair or warranty information, please contact DIRECTV Customer Care at the address and phone number listed below. If the equipment is causing harm to the network, the telephone company may request that you disconnect the equipment until the problem is resolved.

**DIRECTV, Inc.**

2230 E. Imperial Hwy

El Segundo, CA 90245

1-800-DIRECTV

If your home has specially wired alarm equipment connected to the telephone line, ensure the installation of this DIRECTV Satellite Receiver does not disable your alarm equipment. If you have questions about what will disable alarm equipment, consult your alarm company, telephone company or a qualified installer.

**DO NOT DISASSEMBLE THIS EQUIPMENT.** It does not contain any user-serviceable components.

We recommend the installation of an AC surge arrester in the AC outlet to which this equipment is connected. Telephone companies report that electrical surges, typically lightning transients, are very destructive to customer terminal equipment connected to AC power sources.

THE DIRECTV® Receiver INCORPORATES SOFTWARE WHICH IS OWNED BY DIRECTV, INC. (“DIRECTV”) OR ITS THIRD PARTY LICENSORS (the “Software”). BEFORE USING THE RECEIVER PLEASE READ THESE TERMS. IF YOU DO NOT AGREE TO THESE TERMS YOU MAY NOT USE THE RECEIVER AND SHOULD IMMEDIATELY RETURN THE RECEIVER TO DIRECTV OR YOUR SUPPLIER. THESE TERMS ALSO APPLY TO ANY MODIFICATIONS, UPDATES OR SUPPLEMENTS TO THE SOFTWARE PROVIDED TO YOU.

### A. License Grant and Conditions

DIRECTV grants you a non-exclusive, non-transferable, limited license to use the Software solely in executable code form and solely as integrated with, incorporated into, and in conjunction with the Receiver. You must ensure that the copyright, trademark and other protective notices contained in the Software are maintained and not altered or removed. The Software is protected by copyright and other laws and international copyright and other treaties. All title and intellectual property rights in and to the Software and all modifications, updates, enhancements and derivative works of the Software are owned exclusively by DIRECTV or its licensors and you agree to execute any document reasonably requested by DIRECTV to evidence such ownership rights. Certain third party software used in connection with the Receiver may be made directly available to you by the providers thereof. The source code to certain software subject to the GNU GPL and other open source licenses that is used in connection with the Receiver is made available to you by DIRECTV following the written request to DIRECTV. Use of such Software is also subject to the terms of any applicable agreement between you and each such provider. DIRECTV reserves the right to modify, supplement, update and otherwise alter the Software via software download or other modification procedures, and these terms will apply to such Software as modified, supplemented, updated, and otherwise altered.

### B. License Restrictions

You may not copy, modify or transfer the Software, or any copy thereof, in whole or in part. You may not reverse engineer, disassemble, decompile or translate the Software, or otherwise attempt to derive the source code of the Software, except to the extent allowed under any applicable law. Any attempt to transfer any of the rights, duties or obligations of this license agreement is void. You may not rent, lease, load, resell for profit or distribute the Software, or any part thereof. You may not export, transfer or re-export the Software in violation of any applicable law. The Software may include some components that are covered by “free software” licenses, open source licenses and other similar license use rights, which require such components to be used, modified and/or distributed only under the terms of such licenses. Any such components are subject only to the terms of such licenses, and not these Terms.

## C. Ownership of Software and Reservation of Rights

The Software is licensed, not sold, to you for use only under the terms of this license agreement, DIRECTV is NOT transferring title or any ownership rights in the Software to you and DIRECTV and its suppliers reserve all rights not expressly granted to you. Except as stated above, this license agreement does not grant to you any intellectual property rights in the Software.

## D. Termination

These Terms are effective until terminated. You may terminate these Terms by returning the Receiver to DIRECTV or your supplier. These Terms will terminate automatically without notice if you fail to comply with these Terms or any other agreement between you and DIRECTV. Upon termination you must return the Receiver to DIRECTV or your supplier.

## E. Disclaimer

THE SOFTWARE IS (TO THE EXTENT PERMITTED BY LAW) SUPPLIED “AS IS.” NEITHER DIRECTV NOR ANY OF ITS LICENSORS EXPRESSLY MAKES OR PASSES ON TO YOU ANY WARRANTY OR REPRESENTATION ON BEHALF OF DIRECTV OR ITS LICENSORS WITH RESPECT TO THE SOFTWARE, INCLUDING BUT NOT LIMITED TO ANY WARRANTIES, EXPRESS OR IMPLIED, INCLUDING (BUT NOT LIMITED TO) ANY IMPLIED WARRANTIES OF MERCHANTABILITY, SATISFACTORY QUALITY, FITNESS FOR A PARTICULAR PURPOSE, TITLE OR NON-INFRINGEMENT OF THIRD PARTY RIGHTS.

IN NO EVENT WILL DIRECTV OR ITS LICENSORS BE LIABLE TO YOU WITH RESPECT TO THE SOFTWARE FOR ANY DIRECT, INDIRECT, CONSEQUENTIAL, SPECIAL, PUNITIVE OR INCIDENTAL DAMAGE (INCLUDING LOSS OF PROFITS, LOST SAVINGS, LOSS OF DATA OR THE COST OF PROCUREMENT OF SUBSTITUTE GOODS, TECHNOLOGY OR SERVICES) ARISING OUT OF THE USE OR THE INABILITY TO USE THE SOFTWARE, EVEN IF DIRECTV OR ITS LICENSORS HAVE BEEN ADVISED OF THE POSSIBILITY OF SUCH DAMAGES, OR FOR ANY CLAIM BY A THIRD PARTY. Some states or jurisdictions do not allow the exclusion or limitation of incidental, consequential or special damages, so the above limitations may not apply to you.

## F. Third Party Beneficiaries

DIRECTV'S LICENSORS AND SUPPLIERS SHALL BE THIRD PARTY BENEFICIARIES OF THESE LICENSE TERMS, AS APPLICABLE. YOUR USE OF THE RECEIVER CONSTITUTES YOUR ACKNOWLEDGEMENT THAT YOU HAVE READ THESE TERMS AND AGREE TO BE BOUND HEREBY.

## G. Additional Information

Certain additional terms and information for the Software and certain third party software (including the text of licenses applicable to any free, open source and other similar software that may be included in the Software) may be found in the DIRECTV website located at [www.directv.com](http://www.directv.com), and the GNU website located at [www.gnu.org](http://www.gnu.org).

## H. GNU GPL and Open Source Software

Certain components of the Software may be subject to the GNU General Public Licence, Version 2, June 1991 (“GPL”), “free software” licenses and other open source software licenses. The foregoing components of the Software are not and may not be subject to the License Restrictions in Section B above. In compliance with the GPL, DIRECTV, its suppliers, or its third party licensors, upon written request, will make the source code of the software, libraries and associated utilities it uses, together with its modifications (if any), available to the public in source code form. You are free to use, modify and distribute the software and any modifications as long as you comply with the terms of the GPL referred to above and other open source software licenses. The license terms applicable to the GPL may be found in the DIRECTV website located at [www.directv.com](http://www.directv.com), and the GNU website located at [www.gnu.org/licenses/old-licenses/gpl-2.0.html](http://www.gnu.org/licenses/old-licenses/gpl-2.0.html). To request a copy of the applicable source code please write to DIRECTV at:

Attention: Vice President, STB Engineering  
DIRECTV, Inc.  
2230 E. Imperial Highway  
El Segundo, CA 90245

# TERMS AND CONDITIONS FOR USE OF SOFTWARE (“TERMS”)

## GNU GENERAL PUBLIC LICENSE

Version 2, June 1991

Copyright © 1989, 1991 Free Software Foundation, Inc.,  
51 Franklin Street, Fifth Floor, Boston, MA 02110-1301 USA  
Everyone is permitted to copy and distribute verbatim copies  
of this license document, but changing it is not allowed.

### Preamble

The licenses for most software are designed to take away your freedom to share and change it. By contrast, the GNU General Public License is intended to guarantee your freedom to share and change free software--to make sure the software is free for all its users. This General Public License applies to most of the Free Software Foundation's software and to any other program whose authors commit to using it. (Some other Free Software Foundation software is covered by the GNU Lesser General Public License instead.) You can apply it to your programs, too.

When we speak of free software, we are referring to freedom, not price. Our General Public Licenses are designed to make sure that you have the freedom to distribute copies of free software (and charge for this service if you wish), that you receive source code or can get it if you want it, that you can change the software or use pieces of it in new free programs; and that you know you can do these things.

To protect your rights, we need to make restrictions that forbid anyone to deny you these rights or to ask you to surrender the rights. These restrictions translate to certain responsibilities for you if you distribute copies of the software, or if you modify it.



For example, if you distribute copies of such a program, whether gratis or for a fee, you must give the recipients all the rights that you have. You must make sure that they, too, receive or can get the source code. And you must show them these terms so they know their rights.

We protect your rights with two steps: (1) copyright the software, and (2) offer you this license which gives you legal permission to copy, distribute and/or modify the software.

Also, for each author’s protection and ours, we want to make certain that everyone understands that there is no warranty for this free software. If the software is modified by someone else and passed on, we want its recipients to know that what they have is not the original, so that any problems introduced by others will not reflect on the original authors’ reputations.

Finally, any free program is threatened constantly by software patents. We wish to avoid the danger that redistributors of a free program will individually obtain patent licenses, in effect making the program proprietary. To prevent this, we have made it clear that any patent must be licensed for everyone’s free use or not licensed at all.

The precise terms and conditions for copying, distribution and modification follow.

## GNU GENERAL PUBLIC LICENSE

### TERMS AND CONDITIONS FOR COPYING, DISTRIBUTION AND MODIFICATION

0. This License applies to any program or other work which contains a notice placed by the copyright holder saying it may be distributed under the terms of this General Public License. The “Program”, below, refers to any such program or work, and a “work based on the Program” means either the Program or any derivative work under copyright law: that is to say, a work containing the Program or a portion of it, either verbatim or with modifications and/or translated into another language. (Hereinafter, translation is included without limitation in the term “modification”.) Each licensee is addressed as “you”.

## TERMS AND CONDITIONS FOR USE OF SOFTWARE (“TERMS”)

Activities other than copying, distribution and modification are not covered by this License; they are outside its scope. The act of running the Program is not restricted, and the output from the Program is covered only if its contents constitute a work based on the Program (independent of having been made by running the Program). Whether that is true depends on what the Program does.

1. You may copy and distribute verbatim copies of the Program’s source code as you receive it, in any medium, provided that you conspicuously and appropriately publish on each copy an appropriate copyright notice and disclaimer of warranty; keep intact all the notices that refer to this License and to the absence of any warranty; and give any other recipients of the Program a copy of this License along with the Program.

You may charge a fee for the physical act of transferring a copy, and you may at your option offer warranty protection in exchange for a fee.

2. You may modify your copy or copies of the Program or any portion of it, thus forming a work based on the Program, and copy and distribute such modifications or work under the terms of Section 1 above, provided that you also meet all of these conditions:

- a) You must cause the modified files to carry prominent notices stating that you changed the files and the date of any change.
- b) You must cause any work that you distribute or publish, that in whole or in part contains or is derived from the Program or any part thereof, to be licensed as a whole at no charge to all third parties under the terms of this License.
- c) If the modified program normally reads commands interactively when run, you must cause it, when started running for such interactive use in the most ordinary way, to print or display an announcement including an appropriate copyright notice and a notice that there is no warranty (or else, saying that you provide a warranty) and that users may redistribute the program under these conditions, and telling the user how to view a copy of this License. (Exception: if the Program itself is interactive but does not normally print such an announcement, your work based on the Program is not required to print an announcement.)

These requirements apply to the modified work as a whole. If identifiable sections of that work are not derived from the Program, and can be reasonably considered independent and separate works in themselves, then this License, and its terms, do not apply to those

sections when you distribute them as separate works. But when you distribute the same sections as part of a whole which is a work based on the Program, the distribution of the whole must be on the terms of this License, whose permissions for other licensees extend to the entire whole, and thus to each and every part regardless of who wrote it.

Thus, it is not the intent of this section to claim rights or contest your rights to work written entirely by you; rather, the intent is to exercise the right to control the distribution of derivative or collective works based on the Program.

In addition, mere aggregation of another work not based on the Program with the Program (or with a work based on the Program) on a volume of a storage or distribution medium does not bring the other work under the scope of this License.

3. You may copy and distribute the Program (or a work based on it, under Section 2) in object code or executable form under the terms of Sections 1 and 2 above provided that you also do one of the following:

- a) Accompany it with the complete corresponding machine-readable source code, which must be distributed under the terms of Sections 1 and 2 above on a medium customarily used for software interchange; or,
- b) Accompany it with a written offer, valid for at least three years, to give any third party, for a charge no more than your cost of physically performing source distribution, a complete machine-readable copy of the corresponding source code, to be distributed under the terms of Sections 1 and 2 above on a medium customarily used for software interchange; or,
- c) Accompany it with the information you received as to the offer to distribute corresponding source code. (This alternative is allowed only for noncommercial distribution and only if you received the program in object code or executable form with such an offer, in accord with Subsection b above.)

The source code for a work means the preferred form of the work for making modifications to it. For an executable work, complete source code means all the source code for all modules it contains, plus any associated interface definition files, plus the scripts used to control compilation and installation of the executable. However, as a special exception, the source code distributed need not include anything that is normally distributed (in either source or binary form) with the major components (compiler, kernel, and so on) of the

## TERMS AND CONDITIONS FOR USE OF SOFTWARE (“TERMS”)

operating system on which the executable runs, unless that component itself accompanies the executable.

If distribution of executable or object code is made by offering access to copy from a designated place, then offering equivalent access to copy the source code from the same place counts as distribution of the source code, even though third parties are not compelled to copy the source along with the object code.

4. You may not copy, modify, sublicense, or distribute the Program except as expressly provided under this License. Any attempt otherwise to copy, modify, sublicense or distribute the Program is void, and will automatically terminate your rights under this License. However, parties who have received copies, or rights, from you under this License will not have their licenses terminated so long as such parties remain in full compliance.

5. You are not required to accept this License, since you have not signed it. However, nothing else grants you permission to modify or distribute the Program or its derivative works. These actions are prohibited by law if you do not accept this License. Therefore, by modifying or distributing the Program (or any work based on the Program), you indicate your acceptance of this License to do so, and all its terms and conditions for copying, distributing or modifying the Program or works based on it.

6. Each time you redistribute the Program (or any work based on the Program), the recipient automatically receives a license from the original licensor to copy, distribute or modify the Program subject to these terms and conditions. You may not impose any further restrictions on the recipients' exercise of the rights granted herein. You are not responsible for enforcing compliance by third parties to this License.

7. If, as a consequence of a court judgment or allegation of patent infringement or for any other reason (not limited to patent issues), conditions are imposed on you (whether by court order, agreement or otherwise) that contradict the conditions of this License, they do not excuse you from the conditions of this License. If you cannot distribute so as to satisfy simultaneously your obligations under this License and any other pertinent obligations, then as a consequence you may not distribute the Program at all. For example, if a patent license would not permit royalty-free redistribution of the Program by all those who receive copies directly or indirectly through you,

then the only way you could satisfy both it and this License would be to refrain entirely from distribution of the Program. If any portion of this section is held invalid or unenforceable under any particular circumstance, the balance of the section is intended to apply and the section as a whole is intended to apply in other circumstances.

It is not the purpose of this section to induce you to infringe any patents or other property right claims or to contest validity of any such claims; this section has the sole purpose of protecting the integrity of the free software distribution system, which is implemented by public license practices. Many people have made generous contributions to the wide range of software distributed through that system in reliance on consistent application of that system; it is up to the author/donor to decide if he or she is willing to distribute software through any other system and a licensee cannot impose that choice.

This section is intended to make thoroughly clear what is believed to be a consequence of the rest of this License.

8. If the distribution and/or use of the Program is restricted in certain countries either by patents or by copyrighted interfaces, the original copyright holder who places the Program under this License may add an explicit geographical distribution limitation excluding those countries, so that distribution is permitted only in or among countries not thus excluded. In such case, this License incorporates the limitation as if written in the body of this License.

9. The Free Software Foundation may publish revised and/or new versions of the General Public License from time to time. Such new versions will be similar in spirit to the present version, but may differ in detail to address new problems or concerns. Each version is given a distinguishing version number. If the Program specifies a version number of this License which applies to it and “any later version”, you have the option of following the terms and conditions either of that version or of any later version published by the Free Software Foundation. If the Program does not specify a version number of this License, you may choose any version ever published by the Free Software Foundation.

10. If you wish to incorporate parts of the Program into other free programs whose distribution conditions are different, write to the author to ask for permission. For software which is copyrighted by the Free Software Foundation, write to the Free Software

# TERMS AND CONDITIONS FOR USE OF SOFTWARE (“TERMS”)

Foundation; we sometimes make exceptions for this. Our decision will be guided by the two goals of preserving the free status of all derivatives of our free software and of promoting the sharing and reuse of software generally.

## NO WARRANTY

11. BECAUSE THE PROGRAM IS LICENSED FREE OF CHARGE, THERE IS NO WARRANTY FOR THE PROGRAM, TO THE EXTENT PERMITTED BY APPLICABLE LAW. EXCEPT WHEN OTHERWISE STATED IN WRITING THE COPYRIGHT HOLDERS AND/OR OTHER PARTIES PROVIDE THE PROGRAM “AS IS” WITHOUT WARRANTY OF ANY KIND, EITHER EXPRESSED OR IMPLIED, INCLUDING, BUT NOT LIMITED TO, THE IMPLIED WARRANTIES OF MERCHANTABILITY AND FITNESS FOR A PARTICULAR PURPOSE. THE ENTIRE RISK AS TO THE QUALITY AND PERFORMANCE OF THE PROGRAM IS WITH YOU. SHOULD THE PROGRAM PROVE DEFECTIVE, YOU ASSUME THE COST OF ALL NECESSARY SERVICING, REPAIR OR CORRECTION.

12. IN NO EVENT UNLESS REQUIRED BY APPLICABLE LAW OR AGREED TO IN WRITING WILL ANY COPYRIGHT HOLDER, OR ANY OTHER PARTY WHO MAY MODIFY AND/OR REDISTRIBUTE THE PROGRAM AS PERMITTED ABOVE, BE LIABLE TO YOU FOR DAMAGES, INCLUDING ANY GENERAL, SPECIAL, INCIDENTAL OR CONSEQUENTIAL DAMAGES ARISING OUT OF THE USE OR INABILITY TO USE THE PROGRAM (INCLUDING BUT NOT LIMITED TO LOSS OF DATA OR DATA BEING RENDERED INACCURATE OR LOSSES SUSTAINED BY YOU OR THIRD PARTIES OR A FAILURE OF THE PROGRAM TO OPERATE WITH ANY OTHER PROGRAMS), EVEN IF SUCH HOLDER OR OTHER PARTY HAS BEEN ADVISED OF THE POSSIBILITY OF SUCH DAMAGES.

## END OF TERMS AND CONDITIONS

### How to Apply These Terms to Your New Programs

If you develop a new program, and you want it to be of the greatest possible use to the public, the best way to achieve this is to make it free software which everyone can redistribute and change under these terms.

To do so, attach the following notices to the program. It is safest to attach them to the start of each source file to most effectively convey the

exclusion of warranty; and each file should have at least the “copyright” line and a pointer to where the full notice is found.

<one line to give the program’s name and a brief idea of what it does.>

Copyright (C) <year> <name of author>

This program is free software; you can redistribute it and/or modify it under the terms of the GNU General Public License as published by the Free Software Foundation; either version 2 of the License, or (at your option) any later version.

This program is distributed in the hope that it will be useful, but WITHOUT ANY WARRANTY; without even the implied warranty of MERCHANTABILITY or FITNESS FOR A PARTICULAR PURPOSE. See the GNU General Public License for more details. You should have received a copy of the GNU General Public License along with this program; if not, write to the Free Software Foundation, Inc., 51 Franklin Street, Fifth Floor, Boston, MA 02110-1301 USA.

Also add information on how to contact you by electronic and paper mail. If the program is interactive, make it output a short notice like this when it starts in an interactive mode:

Gnomovision version 69, Copyright (C) year name of author

Gnomovision comes with ABSOLUTELY NO WARRANTY; for details type `show w`. This is free software, and you are welcome to redistribute it under certain conditions; type `show c` for details.

The hypothetical commands `show w` and `show c` should show the appropriate parts of the General Public License. Of course, the commands you use may be called something other than `show w` and `show c`; they could even be mouse-clicks or menu items--whatever suits your program.

You should also get your employer (if you work as a programmer) or your school, if any, to sign a “copyright disclaimer” for the program, if necessary. Here is a sample; alter the names:

Yoyodyne, Inc., hereby disclaims all copyright interest in the program `Gnomovision` (which makes passes at compilers) written by James Hacker.

<signature of Ty Coon>, 1 April 1989

Ty Coon, President of Vice

## TERMS AND CONDITIONS FOR USE OF SOFTWARE (“TERMS”)

This General Public License does not permit incorporating your program into proprietary programs. If your program is a subroutine library, you may consider it more useful to permit linking proprietary applications with the library. If this is what you want to do, use the GNU Lesser General Public License instead of this License.



## APPENDICES

---

- APPENDIX 1: RECEIVERS FRONT AND BACK PANELS .....146
- APPENDIX 2: HOW TO NETWORK YOUR RECEIVER .....154
- APPENDIX 3: ABOUT HIGH-DEFINITION .....162

### DIRECTV Plus® HD DVR

#### FRONT PANEL:

The buttons on the front panel perform the same functions as similarly named buttons on the remote control. You can use the front panel buttons at any time, but they are especially useful if you misplace your remote control or the batteries die.

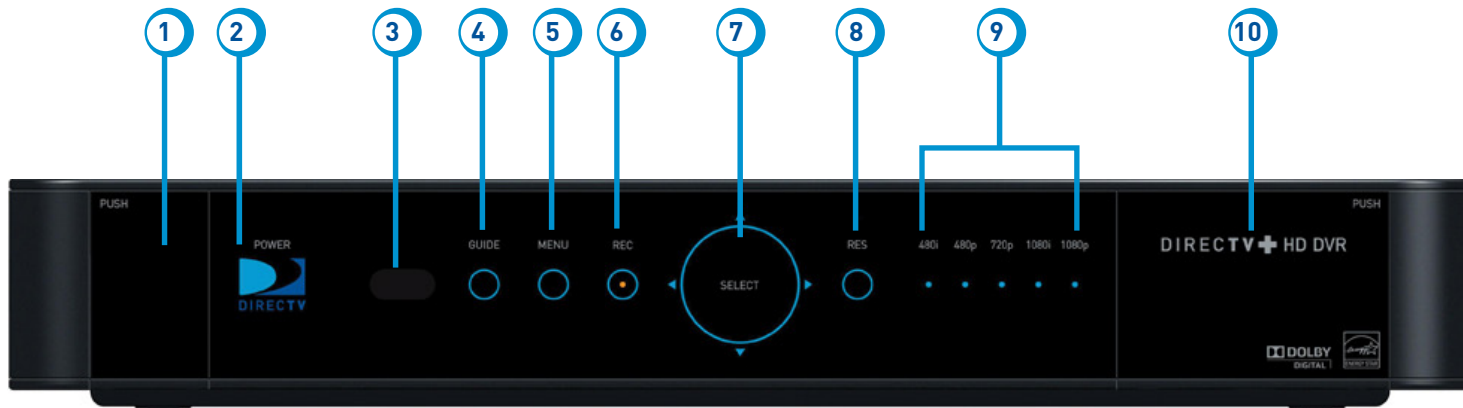

*Your equipment may not look exactly like the model illustrated.*

- 1. DOOR PANEL, USB PORT** – For future use. USB 2.0 Host(FRONT/REAR EACH 5V = 500mA)
- 2. POWER** – Turns your DIRECTV® Receiver on or off. Your DIRECTV® Receiver still records and receives messages when powered off. The power light flashes when you press a key on the remote to let you know it has received the command.
- 3. REMOTE SENSOR** – The infrared sensor picks up commands from the remote control. You cannot have any opaque object between the remote and this sensor or else the command will not get through. If you have an optional RF remote, this sensor is not used. With an optional RF remote you can place your receiver inside a cabinet or any non-metal enclosure and it will receive the remote control commands up to 200 feet away.
- 4. GUIDE** – Displays the on-screen program guide.
- 5. MENU** – Brings up the Main Menu to access settings and services.
- 6. RECORD** – This button lights orange when a recording is in progress.
- 7. SELECT** – Selects the item highlighted.
- 8. RES (RESOLUTION)** – The RES key switches the output resolution of the DIRECTV® Receiver. Each time you press the key, it cycles to the next available resolution: 480i, 480p, 720p, 1080i, and 1080p (supported on some models). Note: The RESOLUTION button on the front panel only changes the resolution. It does not change the screen format (crop, stretch, letterbox, pillarbox). The FORMAT button on the remote control cycles through all of the screen formats and resolutions. See Appendix 3 for details.
- 9. RESOLUTION INDICATORS** – Lights indicate the current resolution setting. 480i is the old analog TV setting. 480p is Enhanced Definition TV, which is less than HD. 720p is the first level of HDTV. 1080p is the highest level of HDTV provided by the receiver. To get the best out of HD, you should be using 720p or higher resolution for your HDTV.
- 10. DOOR / PANEL, ACCESS CARD** – The access card slot, RESET button and receiver ID and model number are located behind the door panel.

## BACK PANEL:

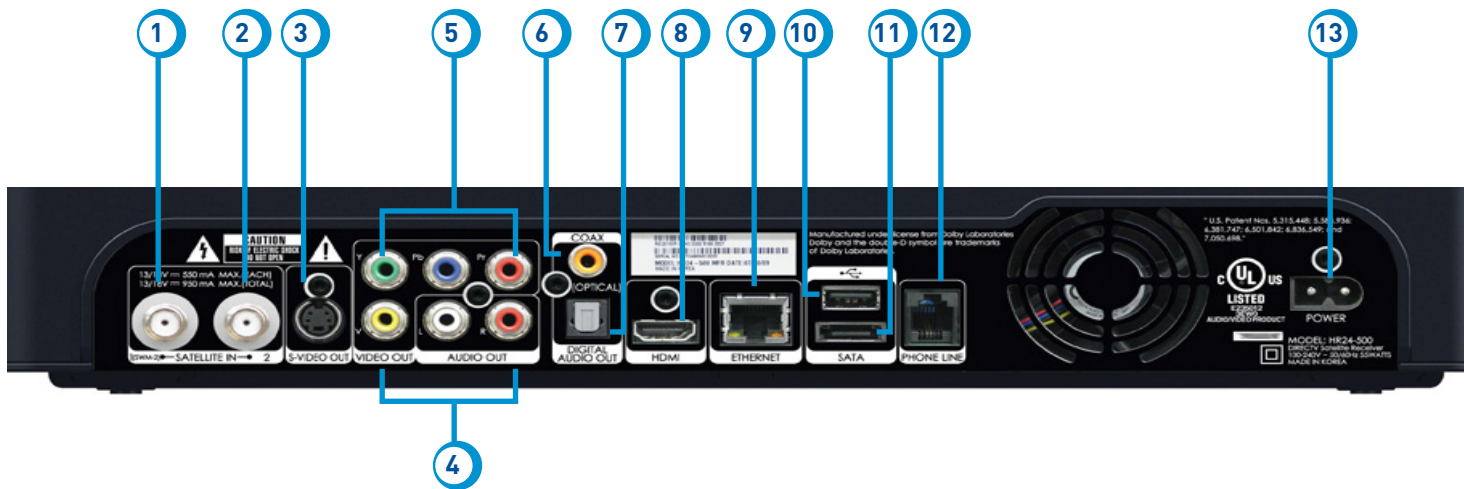

*Your equipment may not look exactly like the model illustrated.*

1. **SATELLITE IN 1 (SWM-2)** – Connect one line from your satellite dish here. A Single Wire Multi-Switch (SWM) connection, if applicable, is made to this satellite in port.
2. **SATELLITE IN 2** – Connect the second line from your satellite dish here.
3. **S-VIDEO OUT** – A Standard-Definition video output.
4. **RCA-Audio/Video Jacks** – Standard-Definition output. You can use the entire row of RCA connectors (yellow, white and red) to feed a VCR or DVD player/burner.
5. **COMPONENT VIDEO OUT**– Use this block to connect up component video cables (green, blue, red) and use the white and red RCA connectors below it for analog audio out.
6. **DIGITAL AUDIO OUT COAXIAL** – Use this digital audio connection for sound.
7. **DIGITAL AUDIO OUT OPTICAL** – Use this digital audio connection for sound.
8. **HDMI** – Use this combination digital video and audio connector for the best picture quality.
9. **ETHERNET** – Connect your home network here to enable DIRECTV on DEMAND and Media Share features.
10. **USB** – For future use. USB 2.0 Host(FRONT/REAR EACH 5V = 500mA)
11. **SATA** – Use this connector to add an external hard drive to your receiver.
12. **PHONE JACK** – Connect your phone line here to enable Pay Per View purchasing and Caller ID (if your phone service package includes it).
13. **POWER** – Your receiver must be plugged in at all times to function properly.

### DIRECTV Plus® DVR

#### FRONT PANEL:

The buttons on the front panel perform the same functions as the remote control. You can use the front panel buttons at any time, but they are there just in case you misplace your remote control or the batteries die.

Besides the buttons on the front panel that are similar to the remote control, here are the other important items:

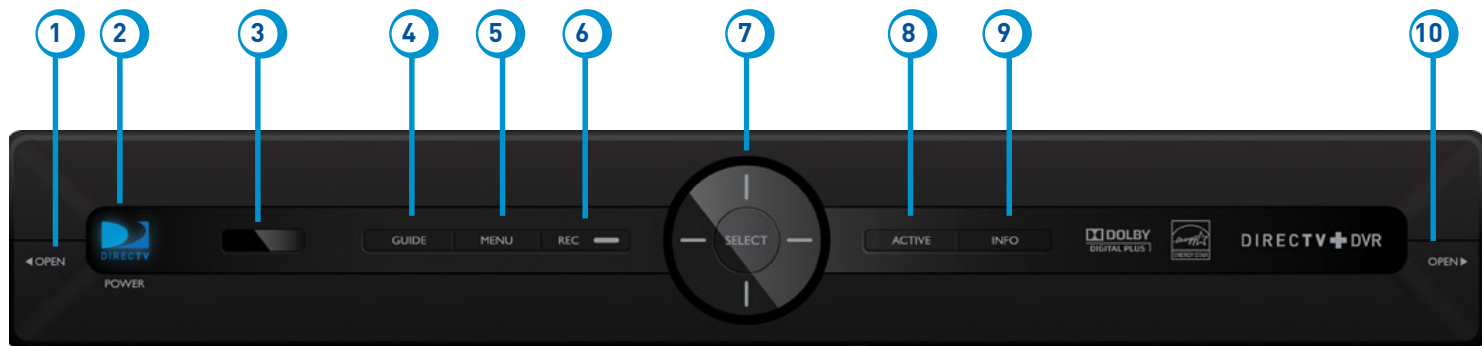

*Your equipment may not look exactly like the model illustrated.*

1. **DOOR PANEL, USB PORT** – For future use. USB 2.0 Host(FRONT/REAR EACH 5V = 500mA)
2. **POWER** – Turns your DIRECTV Plus® DVR on or off. Your DIRECTV Plus® DVR still records and receives messages when powered off. The power light flashes when you press a key on the remote to let you know it has received the command.
3. **REMOTE SENSOR** – The infrared sensor picks up commands from the remote control. You cannot have any opaque object between the remote and this sensor or else the command will not get through. If you have an optional RF remote, this sensor is not used. With an optional RF remote you can place your receiver inside a cabinet or any non-metal enclosure and it will receive the remote control commands up to 200 feet away.
4. **GUIDE** – Displays the on-screen program guide.
5. **MENU** – Brings up the Main Menu to access settings and services.
6. **REC** – This button lights orange to indicate a recording is in progress.
7. **SELECT** – Selects the item highlighted.
8. **ACTIVE** – Displays the DIRECTV Interactive Home Page - local weather and more!
9. **INFO** – Displays channel banner or info for a highlighted program or channel cell.
10. **DOOR PANEL** – The access card slot, RESET button, receiver ID and model number are located behind the door panel.

## BACK PANEL:

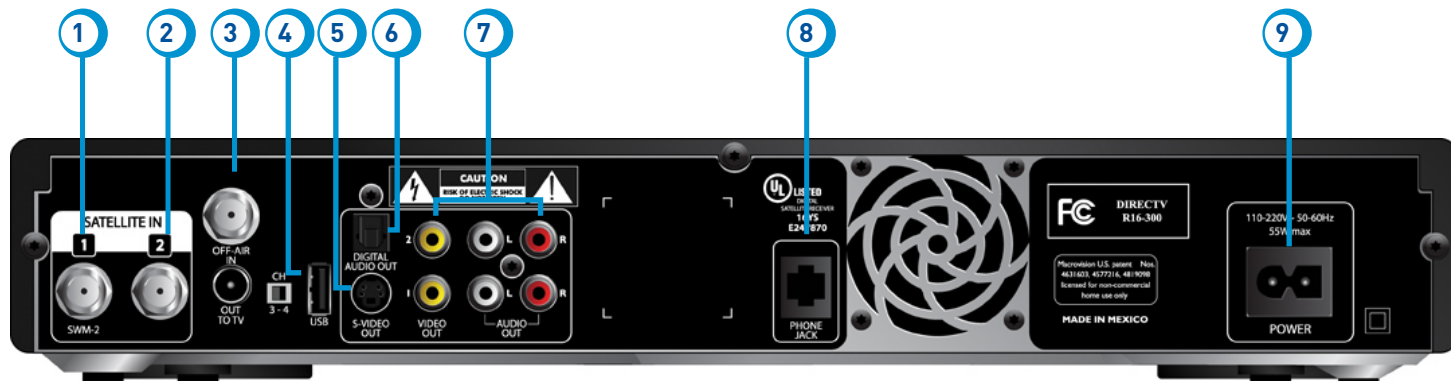

*Your equipment may not look exactly like the model illustrated.*



1. **SATELLITE IN 1 (SWM-2)** – Connect one line from your satellite dish here. A Single Wire Multi-Switch (SWM) connection, if applicable, is made to this satellite in port.
2. **SATELLITE IN 2** – Connect the second line from your satellite dish here.
3. **OFF AIR IN** – Connect a standard TV antenna or cable feed to the DIRECTV Receiver using this jack.
4. **USB** – For future use. USB 2.0 Host(FRONT/REAR EACH 5V = 500mA)
5. **S-VIDEO OUT** – A Standard-Definition video output.
6. **DIGITAL AUDIO OUT OPTICAL** – Use this digital audio connection for sound.
7. **RCA-Audio/Video Jacks** – Standard-Definition output. You can use the entire row of RCA connectors (yellow, white and red) to feed a VCR or DVD player/burner.
8. **PHONE JACK** – Connect your phone line here to enable Pay Per View purchasing and Caller ID (if your phone service package includes it).
9. **POWER** – Your receiver must be plugged in at all times to function properly.

### Network Requirements:

To use your DIRECTV Receiver on your home network, you will need:

- A compatible DIRECTV Receiver, such as the DIRECTV Plus® HD DVR (models HR20 or later) or DIRECTV Plus® DVR (model R22)
- A broadband Internet connection, with a minimum connection speed of 750 kbps or higher (DSL or cable)
- A network router with an available Ethernet port

### There are three (3) ways to connect your receiver to your home network:

1. **Wired** - The fastest, most reliable connection. Your house must be wired for Ethernet, or you must run cables from a network router to your DIRECTV DVR Receiver.
2. **Powerline** - This method requires special Ethernet Adaptors that allow you to connect to your network router via the existing AC power line wiring in your house.
3. **Wireless** - This can be easiest method if you already connect to the Internet via Wi-Fi. However, wireless connections may be slower and somewhat less reliable than wired.

## Wired

### Step 1 - Connect your DIRECTV DVR Receiver to your router

Connect one end of your Ethernet cable to the Ethernet port on the back of your router.

Connect the other end of the Ethernet cable to the Ethernet port on the back of your DIRECTV DVR Receiver.

#### Direct Connection

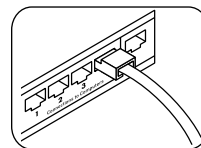
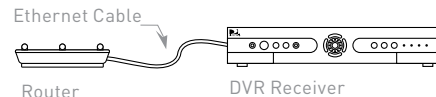

Ethernet cable connects to an unused port on the router

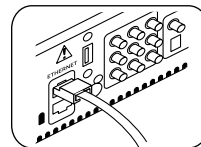

Ethernet cable plugs into receiver

### Step 2 - Verify that you are connected

To verify you are connected:

- Press **MENU** on your DIRECTV Remote
- Select **Parental, Fav's & Setup**
- Select **System Setup**
- Select **Network Setup**
- Choose **Connect Now**
- Select **Continue** after successfully connecting to DIRECTV via the Internet (See figure A).

Select **Done** to complete the setup process (See figure B).

If your DIRECTV DVR Receiver does not immediately recognize the network connection, you will get the option to choose the connection method. Choose **Wired** (See Figure C). Follow the onscreen instructions.

Figure A

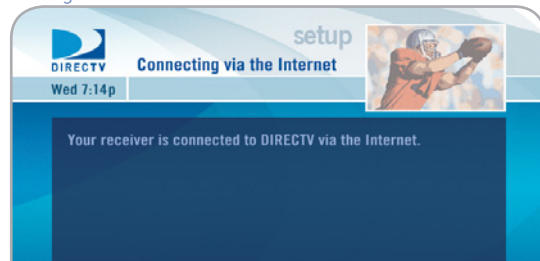

Figure B

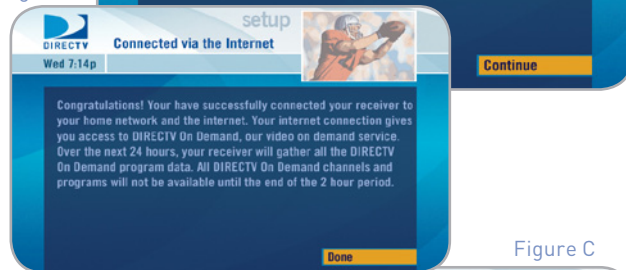
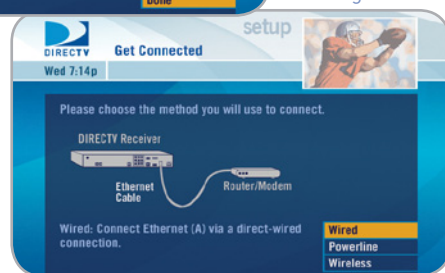

Figure C



## Powerline

Use your home's existing power lines to connect your DSL/cable router to your DIRECTV DVR Receiver via Ethernet Adapters that use HomePlug® or a similar power line technology.

Along with the Network Requirements listed at the beginning of Appendix 3, you will need:

- 2 wall mount Ethernet Adapters
- 2 Ethernet Cables

### Step 1: Connect your router to your Ethernet Adapter

Connect one end of an Ethernet cable to the Ethernet port on the back of your router. Connect the other end of the Ethernet cable to the wall mount Ethernet Adapter.

Plug your wall mount Ethernet Adapter into an electrical outlet.

### Step 2: Connect your DIRECTV DVR Receiver to your second Ethernet Adapter

Connect one end of your second Ethernet cable into your second wall mount Ethernet Adapter. Connect the other end of the Ethernet cable into the Ethernet port on the back of your DIRECTV DVR Receiver. Plug your second wall mount Ethernet Adapter into an electrical outlet.

#### IMPORTANT:

Please be advised that your Ethernet Adapters must be plugged directly into a wall, unless you have a power strip that is certified to work with your Ethernet Adapter.

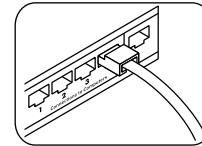

Ethernet cable connects to an unused port on the router.

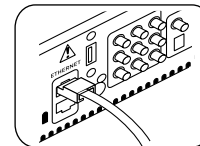
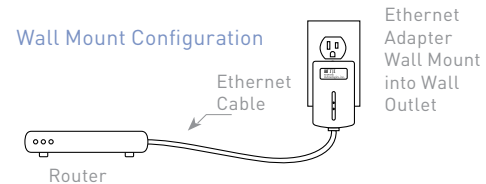

Ethernet cable plugs into receiver

### Step 3 - Verify that you are connected

To verify you are connected:

- Press **MENU** on Your DIRECTV Remote
- Select **Parental, Fav's & Setup**
- Select **System Setup**
- Select **Network Setup**
- Choose **Connect Now**
- Select **Continue** after successfully connecting to DIRECTV via the Internet (See figure A.)

Select **Done** to complete the setup process (See figure B).

If your DIRECTV DVR Receiver does not immediately recognize the network connection, you will get the option to choose the connection method. Choose **Powerline** (See Figure C). Follow the onscreen instructions.

Figure A



Figure B

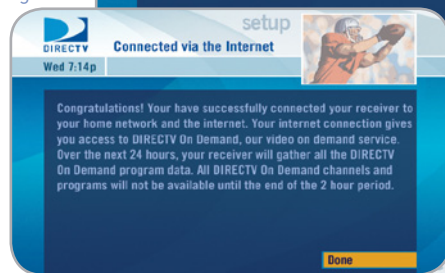
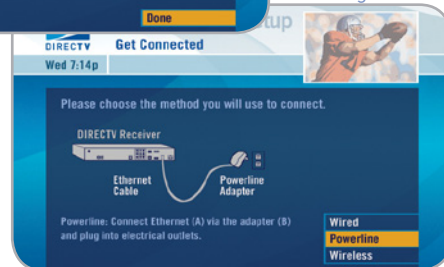

Figure C



### Wireless

Create a wireless connection between your wireless router and your DIRECTV DVR Receiver, so your receiver can access the Internet.

Along with the Network Requirements at the beginning of Appendix 3 you will need:

- A wireless adapter that uses an Ethernet port to connect to a media device. [USB devices are not supported by the DIRECTV DVR Receiver]
- A wireless router (in place of a regular router). You must have initialized your wireless device for your home network before beginning to network your DIRECTV DVR Receiver.

#### Step 1: Connect your DIRECTV HD Receiver to the wireless adapter

Connect one end of the Ethernet cable to the Ethernet port on the back of the wireless adapter. Connect the other end of the Ethernet cable to the Ethernet port on the back of your DIRECTV DVR Receiver.

Plug your wireless adapter into an electrical outlet.

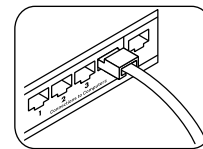
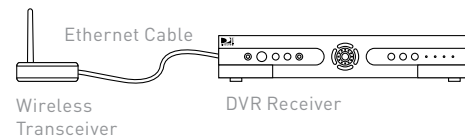

Ethernet cable connects to the Ethernet port of the wireless adapter.

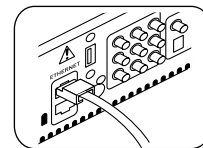

Ethernet cable plugs into DVR Receiver

### Step 2 - Ensure the wireless adapter is recognized by your home network.

- Once your router detects the wireless adapter it will prompt you to configure the two devices.
  - Select **Set Up Now**.
- 
- Highlight your wireless network and press SELECT to display a blue dot next to your network. Then select **Continue**.
  - Follow the on-screen instructions to complete the set-up process of the wireless adapter.

**Note:** If you are having difficulty connecting to the Internet or need more information, visit [www.directv.com/ondemand](http://www.directv.com/ondemand).

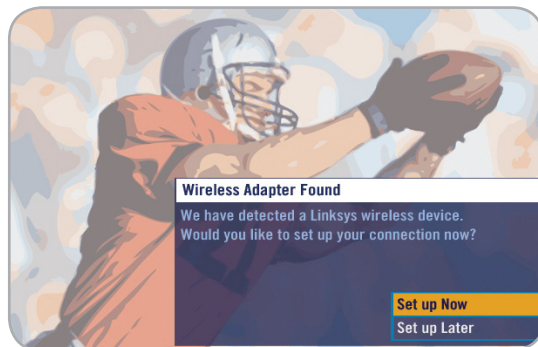



### Step 3 - Verify that you are connected

- Press **MENU** on Your DIRECTV Remote
- Select **Parental, Fav's & Setup**
- Select **System Setup**
- Select **Network Setup**
- Choose **Connect Now**
- Select **Continue** after successfully connecting to DIRECTV via the Internet (See figure A.)

Select **Done** to complete the setup process (See figure B).

If your DIRECTV DVR Receiver does not immediately recognize the network connection, you will get the option to choose the connection method. Choose **Wireless** (See Figure C). Follow the onscreen instructions.

Figure A

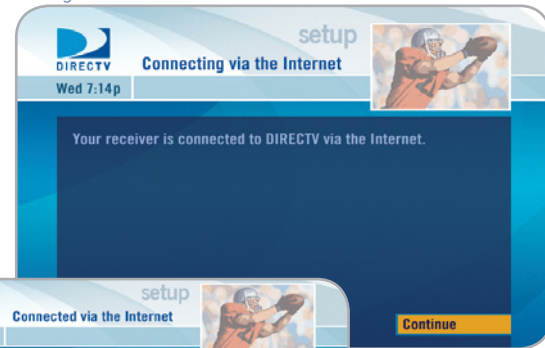

Figure B

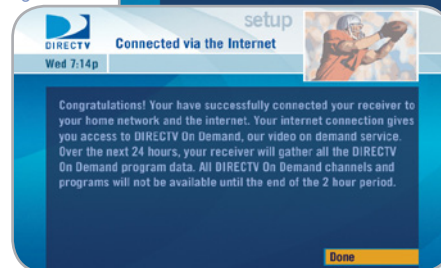
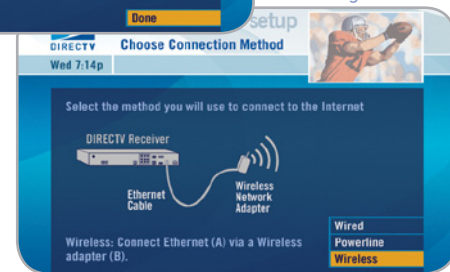

Figure C



## Appendix 3: About High-Definition



This section applies to HD receivers only.

### Aspect Ratio

In addition to resolution and interlacing, a television picture is also defined by its aspect ratio—referring to the shape of the screen as defined by the ratio of the screen's width to its height.

For analog TV, the aspect ratio is 4 units wide by 3 units high (4:3). This is the familiar shape of conventional TVs—slightly wider than they are tall. SDTV and EDTV pictures can be either 4:3 or 16:9. For HDTV broadcasts, the aspect ratio is 16:9—nearly twice as wide as it is tall. This is, not coincidentally, more like the shape of movies shown in theaters, which makes HD an ideal format for viewing movies on TV. You will be able to see much of what is captured on film, but lost on an SDTV display.

### Screen Formats

What if you're watching a nearly square-shaped 4:3 broadcast on a 16:9 TV, or vice versa? The DIRECTV HD Receiver lets you choose from a variety of screen formats to deal with those scenarios. You can set up your preferences for format during Guided Setup and change them at any time.

### Options for Changing Video Output

In order to optimize the display of programs on your television, you may occasionally need to change the resolution and/or screen format. There are two keys that can be used to make changes: the FORMAT key on the remote control and the RES (Resolution) key on the front panel of the DIRECTV HD Receiver.

Pressing the FORMAT button on your remote will cycle the resolutions that you've indicated in System Setup as being supported by your TV, as well as, the screen formats in conjunction with each individual resolution. Available screen formats such as crop, stretch or letter/pillar box, are based on the TV Aspect Ratio you set in System Setup. With each press, an on-screen message will let you know what the current resolution/format setting is.

For example, if you indicated that your TV supports only 1080i, 480i and 480p and it is a 16:9 television, and Native is turned off\*, the cycle of settings for the FORMAT key are as follows:

1st press: 480i/Stretch	6th press: 480p/Crop
2nd press: 480i/Letter box	7th press: 1080i/Stretch
3rd press: 480i/Crop	8th press: 1080i/Letter box
4th press: 480p/Stretch	9th press: 1080i/Crop
5th press: 480p/Letter box	10th press: repeat cycle

**Note:** \* In Native mode, the receiver automatically adjusts resolutions to match the resolution of individual TV programs as they are tuned.

If Native is turned on, the FORMAT key cycles through Stretch, Letter and Crop for the current TV program's native resolution. The FORMAT key allows you to easily cycle all resolution and format settings with a single key until the picture displays the way you like it.

If pressing this key causes a loss of video and audio, continue to press it until the picture returns. (Wait a second between presses to allow the Receiver to change the resolution.) This can happen if your settings include a resolution that your TV doesn't support. To correct this, you'll need to change your resolution setting: Press MENU, select "Parental, Fav's & Setup", "System Setup", "HDTV" and then select "TV Resolutions." Mark or unmark the TV Resolutions to display the resolutions supported by your television.

### Resolution (RES) Key on Receiver Front Panel

This key is used to through cycle all available resolutions on your DIRECTV HD DVR. It does not through cycle format settings. If video and audio are not appearing, it may be because the current resolution setting is not supported by your television. By pressing this key, you can check all available resolutions to see if that solves the problem. The lights next to the RES key on the front panel will light below the resolution to which the receiver is set; they will change with each key press.

### Supported Resolutions

The following table shows the resolutions that can be output from each type of connection:

Output Connection	Available Resolutions
HDMI	1080i, 1080p, 720p, 480i, 480p
Component Video (YPbPr)	1080i, 720p, 480i, 480p
S-Video	480i
Video (RCA Type/Yellow)	480i

**Note:** 720p, 1080i and 1080p are HD formats. 480i and 480p are not. S-Video and RCA outputs display all resolutions as 480i.

### Wide-Screen vs. Standard Formats

#### 4:3 TVs Showing 16:9 programs

For a standard 4:3 TV showing a wide screen program, the program is too wide to fit on the screen. To alleviate this, choose:

- Letterbox

With this format, the 16:9 image is shrunk until the entire width of the program fits on your TV. Since the aspect ratio of the program is maintained, the image is no longer tall enough to fill your screen, so gray or black bars are seen at the top and bottom of the screen. To change the bar color, press MENU, select "Parental, Fav's & Setup", "System Setup", "HDTV" and then "Video." Select the desired bar color. See your TV's owner's manual for information on the best color for your set.

- Stretch

In the Stretch setting, instead of adding bars to the top and bottom, the 16:9 program image is stretched vertically until it's tall enough to fill the screen. Your entire screen will be full, but the program images are stretched to compensate.

- Crop

This format crops (cuts off) the left and right portions of the 16:9 frame so it fits the 4:3 screen.

If your display is a 4:3 format TV or monitor, your format options include these:

For 4:3 program signals:



Fills TV Screen

For 16:9 program signals:



Letterbox



Stretch



Crop

### 16:9 TVs Showing 4:3 programs

For a wide screen 16:9 TV showing a standard 4:3 TV program, the program is too tall to fit the screen. Your choices here include:

#### - Pillar Box

Here the 4:3 image is shrunk until the entire height of the program fits on your TV. Since the aspect ratio is maintained, the image is no longer wide enough to fill the screen, so gray or black bars are seen at the left and right edges. To change the bar color, press MENU, select "Parental, Fav's & Setup", "System Setup", "HDTV" and then "Video." Select the desired bar color option. See your TV's owner's manual for information on the best color for your set.

#### - Stretch

In this setting, instead of adding bars to the sides, the 4:3 program image is stretched horizontally until it's wide enough to fill the screen. Your entire screen will be full, but the images are a little stretched to compensate.

#### - Crop

This format crops (cuts off) the top and bottom of a 4:3 frame, keeping the 4:3 ratio intact.

If your display is a 16:9 format TV or monitor, your format options include these:

For 4:3 program signals:



Pillar Box



Stretch



Crop

For 16:9 program signals:



Fills TV Screen

## A

Access Card - 86, 97, 139, 143  
Activation - 106  
Advance - 16, back cover  
Album - 75  
Artists - 75  
Audio Connections - 101  
Audio Options - 33, 90  
Audio sync - 114  
Autorecord - 59, 63, inside back cover  
Auxiliary Equipment - 102

## B

Back Panel - 140-141, 144-145  
Batteries - 11, 14  
Bookmarks - 37

## C

Cables - 100-101  
Caller ID - 41, 42, 77, 115, 141  
Cast & Crew - 54  
Category Sort- 31  
Channel Banner - 23

Channel Blocks - 83  
Clock - 89  
Closed Captioning - 32, 88  
Component Video Output - 101-103  
Connections - 101-103  
Customer Care - 42

## D

3D - 19  
Date & Time - 31  
Defaults - 73, 96  
Deleting - 28, 49, 69  
Destination Buttons - 15  
Digital Audio - 90, 101-103  
DIRECTV Cinema™ - 52, 54  
DIRECTV Mode - 14  
DIRECTV Protection Plan - 127-128  
DIRECTV on DEMAND - 52-56  
Disc Space Bar - 45  
Display - 87  
Dolby® Digital - 90  
DoublePlay - 35  
Download - 52, 55, 56

DVD burner - 102-103  
DVR - 3, 102-103  
DVR Control Buttons - 14

## E

Episodes - 27, 43, 46, 50  
Error Messages - 107  
Ethernet - 40, 53, 149, 154, 155, 157, 159  
Exit - 15, back cover

## F

FAQs - 98  
Favorite Channels List - 31, 33, 85  
FCC Customer Information - 129-132  
Filtering the Guide - 30  
Folders - 45  
Front Panel - 138, 142

## G

GameSearch™ - 36  
GSN Game Lounge™ - 22  
Guide - 18  
    banner - 20



- channel programs list - 32
- customizing - 31
- favorite channels - 31
- filtering - 30
- jump to a date and time - 31
- options - 31
- sorting programs - 31

Guided Setup - 104

## H

- HDMI - 101, 102
- Help - 42, 98
- History - 70
- Home Page - 15, 46, 53, 54, 55, 151
- High Definition - 162-167

## I

- Icons - 23, 43, 46, inside back cover
- Interactive Channels - 21

## K

- Keep - 45, 47, 71, 75
- Keyword Search - 55

## L

- Language - 23, 33, 88, 90, 104,
- Live Buffer - 34
- Live TV - 16, 34
  - options - 33
  - watching - 18-24
- Local Channels - 18
- Lock (Parental Controls) - 80

## M

- Main Menu - 23, 40-98
- Manage Recordings - 41, 42, 51, 69-73
- Manual Recording - 72
- Mark & Delete - 44
- Media Share - 74
- Messages - 20, 41, 42, 78, 107
- Mini-guide - 20
- Mobile Phone - 39

- Mode Switch - 14, back cover
- Model Number - 124
- Movie Ratings - 81
- Music - 3, 40, 74-75
- Mute - back cover
- My Playlist - 23, 43-47
  - change order - 44
  - DIRECTV® Whole-Home DVR Service- 47-51
  - mark & delete - 44
  - open/close all - 45
  - options - 44
  - sort - 44

## N

- Navigation Buttons - 15
- Network - 47, 93, 154-161
- News Mix Channels - 21

## O

On Demand - See DIRECTV on DEMAND

Other Ratings - 81, 82

## P

Parental Controls - 79-98

adult channels - 83

channel blocks - 80

hours (viewing) - 84

locking - 80

passcode - 80, 81

ratings - 81

spending - 84

unlocking - 81

Passcode - 80, 81

Pausing - 16

Pay Per View - 24, 31, 40

PC - 38, 74

Phone Connection - 100

Photos - 74-76

Playlist (see My Playlist)

Power - 10, 11, 14, 101, 106, 139, 141, 143, 145

Power Surge - 10

Powerline Connection - 157-158

Press and Hold Buttons - 37

Previous Channels - 32

Prioritizer - 71

Program Guide (see Guide)

Progress Bar - 17, 25, 35, 37, 75

Purchases - 70

## Q

Queue - 55, 70

QuickTune - 36

## R

Ratings - 81

RCA connectors - 103, 141, 145

Rear Panel - 140, 144

Recent Searches - 64, 68

Recording

a single show - 25

a series - 27, 50

conflict - 50, 71, 73, 116

defaults - 73

from Live TV - 25, 27

from the guide - 25, 27

light - 138, 139

manually - 73

options - 26, 27

remote - 38

stopping an in-progress - 26, 27

Remote Control - 14-15, 93, back cover

advanced setups - 94

buttons - 14

IR/RF setup - 94

modes - 14, 93

problems - 120

program remote - 93

receiver mode - 94

Remote Recording - 38

Repair - 11, 125

Reset - 92, 106, 139

Resolution - 92, 147, 162-164

Resolution Indicator - 147

Restart - 96

RF Remote - 94

## S

Satellite Data Acquisition - 108  
Satellite Signal Strength - 95  
Scheduler - 38  
Search  
    Search for Shows (SD DVR) - 26,  
    40, 52  
    Smart Search (HD DVR) - 54  
Serial Number - 8  
Series - 26, 27, 43, 50, 71  
Series Manager - 71  
Settings -79  
Setup (see System Setup)  
Shortcut Buttons - 15  
Shortcut Hints - 15  
Software - 21, 106, 133  
Software License - 133  
Song - 75  
Sort - 31, 44  
Sound Effects - 90  
Spending Limits - 81  
SportsMix Channels - 21  
Suggested Searches - 57

Surround Sound - 90, 93, 101, 114  
System Info - 86  
System Messages - 42  
System Settings - 86  
System Setup - 86  
System Software Updates - 106  
System Test - 86, 121  
S-video - 101, 103, 149, 153, 164

## T

Temporarily Unlock - 81  
Terms & Conditions for Use of Software  
- 133-144  
Tickmarks - 16, 37  
To Do List - 69  
Top Movies - 54  
Troubleshooting - 106-121  
TVmail - 78  
TV Problems - 108  
TV Ratings - 82

## U

Unsubscribed Channels - 19  
Unlock (Parental Controls) - 81

## V

VCR - 100-103  
Video - 100-103  
VOD - 55, 56, 65, inside back cover  
VOD Queue - 55

## W

Warranty - 124-126, 128  
Watching  
    live TV - 18  
    your recorded shows - 28  
Whole-Home DVR Service - 47-51  
Wired Connection - 155-156  
Wireless Connection - 159-161

ACTIVATION OF PROGRAMMING SUBJECT TO CREDIT APPROVAL. CREDIT CARD REQUIRED (except in MA and PA). Programming subject to change. DIRECTV Services not available outside the U.S. DIRECTV programming is available separately and independently of DIRECTV System hardware. A valid programming subscription is required to operate DIRECTV System hardware. Activate your DIRECTV programming today at 1-800-DIRECTV (1-800-347-3288). ©2010 DIRECTV, Inc., DIRECTV and the Cyclone Design logo, DIRECTV Active, DIRECTV INTERACTIVE, DIRECTV PLUS, HomePlug, GSN Game Lounge™ and the DIRECTV Plus DVR and DIRECTV Plus HD DVR logos are trademarks of DIRECTV, Inc.

This item incorporates copy protection technology that is protected by U.S. patents and other intellectual property rights of Rovi Corporation. Reverse engineering and disassembly are prohibited.

Due to restrictions imposed by copyright holders, certain programming may include content protection measures that may restrict viewing in high-definition and/or recording with certain consumer electronics equipment attached to the receiver. Please contact the manufacturer of such equipment for additional information.

THIS PRODUCT IS LICENSED UNDER THE AVC PATENT PORTFOLIO LICENSE FOR THE PERSONAL AND NON-COMMERCIAL USE OF A CONSUMER TO (i) ENCODE VIDEO IN COMPLIANCE WITH THE AVC STANDARD ("AVC VIDEO") AND/OR (ii) DECODE AVC VIDEO THAT WAS ENCODED BY A CONSUMER ENGAGED IN A PERSONAL AND NON-COMMERCIAL ACTIVITY AND/OR WAS OBTAINED FROM A VIDEO PROVIDER LICENSED TO PROVIDE AVC VIDEO. NO LICENSE IS GRANTED OR SHALL BE IMPLIED FOR ANY OTHER USE. ADDITIONAL INFORMATION MAY BE OBTAINED FROM MPEG LA, L.L.C. SEE [HTTP://WWW.MPEGLA.COM](http://WWW.MPEGLA.COM)

**DVR Combo Guide Version 3.2 - 070810**



# Icon Reference

## Arrow Icons



Indicate that a show's start or end time is earlier or later than is visible in the Guide program cell.



LEFT and RIGHT arrows on the remote offer special functionality.



Objects are scrollable above or below the visible window.



UP and DOWN arrows on the receiver front panel offer special functionality.

## Other Icons



Indicates a program is set to record.



Indicates record has been set for all episodes of an ongoing program.



Indicates showing that was set by the user conflicts with another showing.



Indicates showing that was set by the user was canceled by the scheduler due to an unexpected conflict.



Shows Autorecord has been set for matching programs in a Search.



Indicates a recorded or live-stored video is fast forwarding at normal speed.



Indicated a recorded or live-stored video is rewinding at normal speed.



Indicates current video is paused.



This key plays current video when paused; it displays the control bar when already playing.



Denotes one or more alternate audio tracks available for a program.



Indicates one or more new messages are in the Inbox.



Shows that Parental Control limits are currently "locked."



Shows that limits are temporarily unlocked.























Shows that there are no current limits imposed.



Indicates a rating level or channel that is blocked via Parental Controls.

## Other Icons

	Program is currently downloading.
	Indicates program shown in letterbox format.
	Denotes an error condition has occurred.
	Appears when at least one rating or channel is allowed.
	Appears when at least one rating or channel is blocked.
	Used to create/enter passcodes in parental controls.
	
	On screen color hint indicating a special function activated by pressing the related color button on the remote control.
	
	
	Indicates the scheduled PPV is set to purchase.
	Program is currently downloading.
	Indicates the program is/will be broadcast in High-Definition format. 
	Indicates program is ready to watch.
	Indicates a Program is in the Queue.
	All episodes of an ongoing programs are in the Queue.
	Indicates a program is about to expire
	Indicates that the programs comes from DIRECTV on DEMAND.
	Indicates a recorded program is not available for viewing.

## MODE SWITCH

Changes remote to control other equipment for example a DVD Player.

**TV INPUT** Changes the "source" - the piece of equipment whose signal is displayed on your TV.

**FORMAT** Cycles through screen formats (crop, stretch, pillar box, letter box) and resolutions.

**STOP** Stops Recorded Video

**REPLAY** Jumps back 6 seconds. Hold down to jump back to the beginning.

**REWIND** Press up to four times to rewind at increasing speed.

**PAUSE** Pauses current video.

**ACTIVE** Display the DIRECTV Active Channel/local weather and more!

**GUIDE** Display the on-screen program guide.

**SELECT** Selects any highlighted item.

**BACK** Takes you back one navigation screen.

**MENU** Display a compact menu of settings and services.

**RED** In Guide, jumps 12 hours back; other functions vary - look for on-screen hints.

**GREEN** In Guide, jumps 12 hours forward; other functions vary - look for hint on screen.

**VOLUME** Raises or lowers volume.

**MUTE** Toggles sound volume on/off.

**NUMBERS & DASH** Change to a channel directly; also input numbers when needed in on-screen menus.

**DIRECTV & TV POWER ON** Turns your DIRECTV® Receiver and TV on and off together.

**POWER** Turn your DIRECTV® Receiver or other equipment on and off separately, as selected with MODE switch.

**ADVANCE\*** Jumps ahead 30 seconds. Hold down to jump forward to the end.

**PLAY\*** Play current video; press and hold for slow motion.

**FFWD\*** Press up to four times to fast forward at increasing speeds.

**RECORD\*** In Live TV, records current program; in the Guide, sets one-touch record for highlighted program.

**LIST** Displays the Playlist

**EXIT** Exits any menu and returns to last channel viewed.

**ARROWS** Move highlight to items in whatever direction needed.

**INFO** Displays info for a highlighted or full screen program.

**BLUE** In live TV, displays the Mini guide; other functions vary - look for on-screen hints.

**YELLOW** In full screen TV, shows live TV options; other functions vary - look for on-screen hints.

**CHAN/PAGE** In live TV, changes channel up or down; in a menu, such as the guide, scrolls page up and down.

**PREV** Tunes to previous channel viewed.

**ENTER** Activates channel number entries quickly.



Keys in orange text can be programmed to function with your VCR, DVD player or other stand alone equipment.

\* These descriptions apply to DIRECTV Digital Video Recorders. Other equipment may behave differently.



DVRO3.208JUL2010