

brother®

BASIC USER'S GUIDE

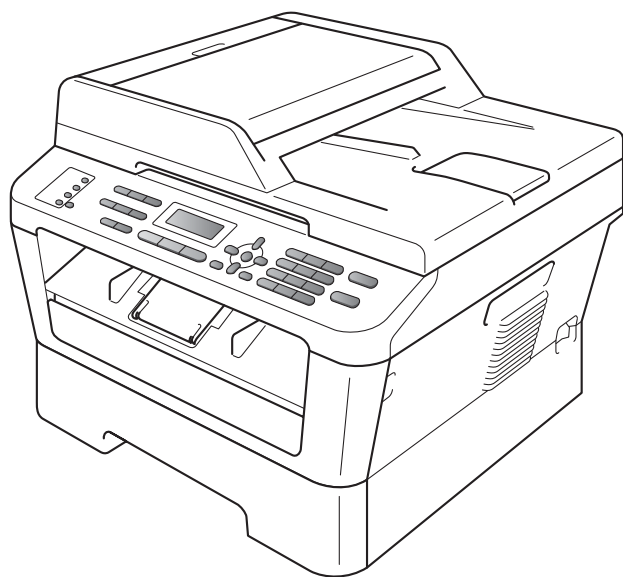

MFC-7360N
MFC-7460DN
MFC-7860DW

Not all models are available in all countries.

Version 0

USA/CAN

If you need to call Customer Service

Please complete the following information for future reference:

**Model Number: MFC-7360N, MFC-7460DN and
MFC-7860DW**

(Circle your model number)

Serial Number: ¹ _____

Date of Purchase: _____

Place of Purchase: _____

¹ The serial number is on the back of the unit. Retain this User's Guide with your sales receipt as a permanent record of your purchase, in the event of theft, fire or warranty service.

Register your product on-line at

<http://www.brother.com/registration/>

By registering your product with Brother, you will be recorded as the original owner of the product. Your registration with Brother:

- may serve as confirmation of the purchase date of your product should you lose your receipt;
- may support an insurance claim by you in the event of product loss covered by insurance; and,
- will help us notify you of enhancements to your product and special offers.

The most convenient and efficient way to register your new product is online at <http://www.brother.com/registration/>.

Brother numbers

! IMPORTANT

For technical help, you must call the country where you bought the machine. Calls must be made *from within* that country.

Register your product

By registering your product with Brother International Corporation, you will be recorded as the original owner of the product. Your registration with Brother:

- may serve as confirmation of the purchase date of your product should you lose your receipt;
- may support an insurance claim by you in the event of product loss covered by insurance; and,
- will help us notify you of enhancements to your product and special offers.

Please complete and fax the Brother Warranty Registration and Test Sheet or, for your convenience and most efficient way to register your new product, register on-line at

<http://www.brother.com/registration/>

FAQs (frequently asked questions)

The Brother Solutions Center is our one-stop resource for all your Fax Machine/Multi-Function Center needs. You can download the latest software and utilities and read FAQs and troubleshooting tips to learn how to get the most from your Brother product.

<http://solutions.brother.com/>



Note

You can check here for Brother driver updates.

To keep your machine's performance up to date, check here for the latest firmware upgrade.

For Customer Service

In USA: 1-877-BROTHER (1-877-276-8437)
1-901-379-1215 (fax)

In Canada: 1-877-BROTHER
(514) 685-4898 (fax)

Service Center Locator (USA only)

For the location of a Brother authorized service center, call 1-877-BROTHER (1-877-276-8437) or visit us on-line at <http://www.brother-usa.com/service/>.

Service Center Locations (Canada only)

For the location of a Brother authorized service center, call 1-877-BROTHER.

Ordering accessories and supplies

For best quality results use only genuine Brother accessories, which are available at most Brother retailers. If you cannot find the accessory you need and you have a Visa, MasterCard, Discover, or American Express credit card, you can order accessories directly from Brother. (You can visit us online for a complete selection of the Brother accessories and supplies that are available for purchase.)



Note

In Canada, only Visa and MasterCard are accepted.

In USA: 1-877-552-MALL (1-877-552-6255)
1-800-947-1445 (fax)

<http://www.brothermall.com/>

In Canada: 1-877-BROTHER

<http://www.brother.ca/>

Description	Item
Toner Cartridge	TN-420 (Approx. 1,200 pages) ^{1 2 3}
	TN-450 (Approx. 2,600 pages) ^{1 2 4}
Drum Unit	DR-420 (Approx. 12,000 pages) ^{5 6}
Telephone Line Cord	LG3077001
Basic User's Guide	LX5016001 (English for USA and Canada)
	LX5016002 (French for Canada)
Quick Setup Guide	(MFC-7360N and MFC-7460DN) LX5112001 (English for USA and Canada)
	(MFC-7860DW) LX5688001 (English for USA and Canada)
	(MFC-7360N and MFC-7460DN) LX5112002 (French for Canada)
	(MFC-7860DW) LX5688002 (French for Canada)

¹ Letter or A4 size single-sided pages.

² Approx. cartridge yield is declared in accordance with ISO/IEC 19752.

³ Standard toner cartridge

⁴ High capacity toner cartridge

⁵ 1 page per job.

⁶ Drum life is approximate and may vary by type of use.

Notice - Disclaimer of Warranties (USA and Canada)

BROTHER'S LICENSOR(S), AND THEIR DIRECTORS, OFFICERS, EMPLOYEES OR AGENTS (COLLECTIVELY BROTHER'S LICENSOR) MAKE NO WARRANTIES, EXPRESS OR IMPLIED, INCLUDING WITHOUT LIMITATION THE IMPLIED WARRANTIES OF MERCHANTABILITY AND FITNESS FOR A PARTICULAR PURPOSE, REGARDING THE SOFTWARE. BROTHER'S LICENSOR(S) DOES NOT WARRANT, GUARANTEE OR MAKE ANY REPRESENTATIONS REGARDING THE USE OR THE RESULTS OF THE USE OF THE SOFTWARE IN TERMS OF ITS CORRECTNESS, ACCURACY, RELIABILITY, CURRENTNESS OR OTHERWISE. THE ENTIRE RISK AS TO THE RESULTS AND PERFORMANCE OF THE SOFTWARE IS ASSUMED BY YOU. THE EXCLUSION OF IMPLIED WARRANTIES IS NOT PERMITTED BY SOME STATES IN THE USA AND SOME PROVINCES IN CANADA. THE ABOVE EXCLUSION MAY NOT APPLY TO YOU.

IN NO EVENT WILL BROTHER'S LICENSOR(S) BE LIABLE TO YOU FOR ANY CONSEQUENTIAL, INCIDENTAL OR INDIRECT DAMAGES (INCLUDING DAMAGES FOR LOSS OF BUSINESS PROFITS, BUSINESS INTERRUPTION, LOSS OF BUSINESS INFORMATION, AND THE LIKE) ARISING OUT OF THE USE OR INABILITY TO USE THE SOFTWARE EVEN IF BROTHER'S LICENSOR HAS BEEN ADVISED OF THE POSSIBILITY OF SUCH DAMAGES. BECAUSE SOME STATES IN THE USA AND SOME PROVINCES IN CANADA DO NOT ALLOW THE EXCLUSION OR LIMITATION OF LIABILITY FOR CONSEQUENTIAL OR INCIDENTAL DAMAGES, THE ABOVE LIMITATIONS MAY NOT APPLY TO YOU. IN ANY EVENT BROTHER'S LICENSOR'S LIABILITY TO YOU FOR ACTUAL DAMAGES FROM ANY CAUSE WHATSOEVER, AND REGARDLESS OF THE FORM OF THE ACTION (WHETHER IN CONTRACT, TORT (INCLUDING NEGLIGENCE), PRODUCT LIABILITY OR OTHERWISE), WILL BE LIMITED TO \$50.

Compilation and Publication Notice

Under the supervision of Brother Industries Ltd., this manual has been compiled and published, covering the latest product descriptions and specifications.

The contents of this manual and the specifications of this product are subject to change without notice.

Brother reserves the right to make changes without notice in the specifications and materials contained herein and shall not be responsible for any damages (including consequential) caused by reliance on the materials presented, including but not limited to typographical and other errors relating to the publication.

Brother® One-Year Limited Warranty and Replacement Service (USA Only)

Who is covered:

- This limited warranty (“warranty”) is given only to the original end-user/retail purchaser (referred to in this warranty as “Original Purchaser”) of the accompanying product, consumables and accessories (collectively referred to in this warranty as “this Product”).
- If you purchased a product from someone other than an authorized Brother reseller in the United States or if the product was used (including but not limited to floor models or refurbished product), prior to your purchase you are not the Original Purchaser and the product that you purchased is not covered by this warranty.

What is covered:

- This Product includes a Machine and Consumable and Accessory Items. Consumable and Accessory Items include but are not limited to print heads, toner, drums, ink cartridges, print cartridges, cordless handset battery, refill ribbons, therma PLUS paper and thermal paper.
- Except as otherwise provided herein, Brother warrants that the Machine and the accompanying Consumable and Accessory Items will be free from defects in materials and workmanship, when used under normal conditions.
- This warranty applies only to products purchased and used in the United States. For products purchased in, but used outside, the United States, this warranty covers only warranty service within the United States (and does not include shipping outside the United States).

What is the length of the Warranty Periods:

- Machines: one year from the original purchase date.
- Accompanying Consumable and Accessory Items: 90 days from the original purchase date or the rated life of consumable, whichever comes first.

What is NOT covered:

This warranty does not cover:

- 1 Physical damage to this Product;
- 2 Damage caused by improper installation, improper or abnormal use, misuse, neglect or accident (including but not limited to transporting this Product without the proper preparation and/or packaging);
- 3 Damage caused by another device or software used with this Product (including but not limited to damage resulting from use of non Brother®-brand parts and Consumable and Accessory Items);

- 4 Consumable and Accessory Items that expired in accordance with a rated life;
- 5 Problems arising from other than defects in materials or workmanship; and,
- 6 Normal Periodic Maintenance Items, such as Paper Feeding Kit, Fuser and Laser Units.

This limited warranty is VOID if this Product has been altered or modified in any way (including but not limited to attempted warranty repair without authorization from Brother and/or alteration/removal of the serial number).

What to do if you think your Product is eligible for warranty service:

Report your issue to either our Customer Service Hotline at 1-877-BROTHER (1-877-276-8437) or to a Brother Authorized Service Center **within the applicable warranty period.** Supply Brother or the Brother Authorized Service Center with a copy of your dated bill of sale showing that this Product was purchased within the U.S. For the name of local Brother Authorized Service Center(s), call 1-877-BROTHER (1-877-276-8437) or visit www.brother-usa.com.

What Brother will ask you to do:

After contacting Brother or a Brother Authorized Service Center, you may be required to deliver (by hand if you prefer) or send the Product properly packaged, freight prepaid, to the Authorized Service Center together with a photocopy of your bill of sale. **You are responsible for the cost of shipping, packing product, and insurance (if you desire). You are also responsible for loss or damage to this Product in shipping.**

What Brother will do:

If the problem reported concerning your Machine and/or accompanying Consumable and Accessory Items is covered by this warranty and if you first reported the problem to Brother or an Authorized Service Center within the applicable warranty period, Brother or its Authorized Service Center will repair or replace the Machine and/or accompanying Consumable and Accessory Items at no charge to you for parts or labor. The decision as to whether to repair or replace the Machine and/or accompanying Consumable and Accessory Items is made by Brother in its sole discretion. Brother reserves the right to supply a refurbished or remanufactured replacement

Brother® One-Year Limited Warranty and Replacement Service (USA Only)

Machine and/or accompanying Consumable and Accessory Items and use refurbished parts provided such replacement products conform to the manufacturer's specifications for new product/parts. The repaired or replacement Machine and/or accompanying Consumable and Accessory Items will be returned to you freight prepaid or made available for you to pick up at a conveniently located Authorized Service Center.

If the Machine and/or accompanying Consumable and Accessory Items are not covered by this warranty (either stage), you will be charged for shipping the Machine and/or accompanying Consumable and Accessory Items back to you and charged for any service and/or replacement parts/products at Brother's then current published rates.

The foregoing are your sole (i.e., only) and exclusive remedies under this warranty.

What happens when Brother elects to replace your Machine:

When a replacement Machine is authorized by Brother, and you have delivered the Machine to an Authorized Service Center, the Authorized Service Center will provide you with a replacement Machine after receiving one from Brother. If you are dealing directly with Brother's Express Exchange Service Brother will send to you a replacement Machine shipped for receipt within two business days, with the understanding that you will, after receipt of the replacement Machine, supply the required proof of purchase information, together with the Machine that Brother agreed to replace. You are then expected to pack the Machine that Brother agreed to replace in the package from the replacement Machine and return it to Brother using the pre-paid freight bill supplied by Brother in accordance with the instructions provided by Brother. Since you will be in possession of two machines, Brother will require that you provide a valid major credit card number. Brother will issue a hold against the credit card account number that you provide until Brother receives your original Product and determines that your original Product is entitled to warranty coverage. Your credit card will be charged up to the cost of a new Product only if: (i) you do not return your original Product to Brother within five (5) business days; (ii) the problems with your original Product are not covered by the limited warranty; (iii) the proper packaging instructions are not followed and has caused damage to the product; or (iv) the warranty period on your original Product has expired or has not been sufficiently validated with a copy of the proof of

purchase (bill of sale). The replacement Machine you receive (even if refurbished or remanufactured) will be covered by the balance of the limited warranty period remaining on the original Product, plus an additional thirty (30) days. You will keep the replacement Machine that is sent to you and your original Machine shall become the property of Brother. **Retain your original Accessory Items and a copy of the return freight bill, signed by the courier.**

Limitations:

Brother is not responsible for damage to or loss of any equipment, media, programs or data related to the use of this Product. Except for the repair or replacement as described above, Brother shall not be liable for any direct, indirect, incidental or consequential damages or specific relief. Because some states do not allow the exclusion or limitation of consequential or incidental damages, the above limitation may not apply to you.

THIS WARRANTY IS GIVEN IN LIEU OF ALL OTHER WARRANTIES, WRITTEN OR ORAL, WHETHER EXPRESSED BY AFFIRMATION, PROMISE, DESCRIPTION, DRAWING, MODEL OR SAMPLE. ANY AND ALL WARRANTIES OTHER THAN THIS ONE, WHETHER EXPRESS OR IMPLIED, INCLUDING IMPLIED WARRANTIES OF MERCHANTABILITY AND FITNESS FOR A PARTICULAR PURPOSE, ARE HEREBY DISCLAIMED.

- This Limited Warranty is the only warranty that Brother is giving for this Product. It is the *final expression and the exclusive and only statement* of Brother's obligations to you. It replaces all other agreements and understandings that you may have with Brother or its representatives.
- This warranty gives you certain rights and you may also have other rights that may vary from state to state.
- This Limited Warranty (and Brother's obligation to you) may not be changed in any way unless you and Brother sign the same piece of paper in which we (1) refer to this Product and your bill of sale date, (2) describe the change to this warranty and (3) agree to make that change.

Important: *We recommend that you keep all original packing materials, in the event that you ship this Product.*

BROTHER MULTIFUNCTION CENTER® / FAX MACHINE LIMITED WARRANTY (Canada only)

Pursuant to the limited warranty of 1 year from the date of purchase for labour and parts, Brother International Corporation (Canada) Ltd. ("Brother"), or its Authorized Service Centres, will repair or replace (at Brother's sole discretion) this MFC/Fax machine free of charge if defective in material or workmanship. This warranty applies only to products purchased and used in Canada.

This limited Warranty does not include cleaning, consumables (including, without limitation, ink cartridges, print cartridges, print rolls, thermal paper rolls, toner cartridges, drum units, OPC belts, fixing units, print heads, paper feed rollers, transfer rolls, cleaning rollers, waste toner packs, oil bottles) or damage caused by accident, neglect, misuse or improper installation or operation, any damage caused from service, maintenance, modifications, or tampering by anyone other than a Brother Authorized Service Representative, or if shipped out of the country.

The use of supplies or consumable items that are non-Brother products may void your warranty. This limited warranty ceases when this machine is rented, sold, or otherwise disposed of. Operation of the MFC/Fax machine in excess of the specifications or with the Serial Number or Rating Label removed shall be deemed abuse and all repairs thereafter shall be the sole liability of the end-user/purchaser.

In order to obtain warranty service, the MFC/Fax machine must be delivered or shipped freight prepaid by the end-user/purchaser to a "Brother" Authorized Service Centre, together with your Canadian Proof of Purchase in the form of a Sales Receipt.

When shipping or transporting your MFC/Fax machine, please refer to your Operation Manual for the proper packaging procedures.

For Laser units: Failure to remove the Toner Cartridge (and Toner Drum Unit, waste toner packs or oil bottles on applicable models) during shipping or transport will cause severe damage to the Laser MFC/Fax machine and will void the Warranty.

For inkjet units: (When shipping your Inkjet MFC/Fax machine remove the ink cartridges and replace them with the original protective parts. If original protective parts are not available, leave ink cartridges installed. Please avoid shipping the unit without original protective parts or ink cartridges.) Damage to your print head resulting from packing the Inkjet MFC/Fax machine without the ink cartridges or the protective parts will void your warranty.

Improper packaging may cause severe damage to the machine during shipping and will void the warranty.

BROTHER DISCLAIMS ALL OTHER WARRANTIES EXPRESSED OR IMPLIED INCLUDING, WITHOUT LIMITATIONS, ANY IMPLIED WARRANTIES OF MERCHANTABILITY OR FITNESS FOR A PARTICULAR PURPOSE, EXCEPT TO THE EXTENT THAT ANY WARRANTIES IMPLIED BY LAW CANNOT BE VALIDLY WAIVED.

No oral or written information, advice or representation provided by Brother, its Authorized Service Centres, Distributors, Dealers, Agents or employees, shall create another warranty or modify this warranty. The warranty states Brother's entire liability and your exclusive remedy against Brother for any failure of the MFC/Fax machine to operate properly.

Neither Brother nor anyone else involved in the development, production, or delivery of this MFC/Fax machine shall be liable for any indirect, incidental, special, consequential, exemplary, or punitive damages, including lost profits, arising from the use of or inability to use the product, even if advised by the end user/purchaser of the possibility of such damages. Since some Provinces do not allow the above limitation of liability, such limitation, may not apply to you.

This Limited Warranty gives you specific legal rights and you may also have other rights which vary from Province to Province.

Warranty Service is available at Brother Authorized Service Centres throughout Canada. For Technical Assistance or for the name and location of your nearest Authorized Service Centre call 1-877-BROTHER.

The Brother logo, consisting of the word "brother" in a lowercase, bold, sans-serif font, with a registered trademark symbol (®) to the upper right of the letter "r".

Internet support: support@brother.ca or browse Brother's Web Site www.brother.ca.

User's Guides and where do I find it?

Which manual?	What's in it?	Where is it?
Safety and Legal	Read this Guide first. Please read the Safety Instructions before you set up your machine. See this Guide for trademarks and legal limitations.	Printed / In the Box
Quick Setup Guide	Follow the instructions for setting up your machine and installing the drivers and software for the operating system and connection type you are using.	
Basic User's Guide	Learn the basic Fax, Copy and Scan operations and how to replace consumables. See troubleshooting tips.	
Advanced User's Guide	Learn more advanced operations: Fax, Copy, security features, printing reports, and performing routine maintenance.	PDF file / Documentation CD-ROM / In the Box
Software User's Guide	Follow these instructions for Printing, Scanning, Network Scanning, Remote Setup, PC-Fax, and using the Brother ControlCenter utility.	
Network Glossary	This Guide provides basic information about advanced network features of Brother machines along with explanations about general networking and common terms.	
Network User's Guide	This Guide provides useful information about wired and wireless network settings and security settings using the Brother machine. You can also find supported protocol information for your machine and detailed troubleshooting tips.	

Table of Contents

(BASIC USER'S GUIDE)

1	General information	1
	Using the documentation	1
	Symbols and conventions used in the documentation	1
	Accessing the Advanced User's Guide, Software User's Guide and Network User's Guide	2
	Viewing Documentation	2
	Accessing Brother Support (Windows®)	4
	Accessing Brother Support (Macintosh)	5
	Control panel overview	6
2	Loading paper	9
	Loading paper and print media	9
	Loading paper in the standard paper tray	9
	Loading paper in the manual feed slot	11
	Unscannable and unprintable areas	16
	Paper settings	17
	Paper Type	17
	Paper Size	17
	Acceptable paper and other print media	17
	Recommended paper and print media	17
	Type and size of paper	18
	Handling and using special paper	19
3	Loading documents	22
	How to load documents	22
	Using the automatic document feeder (ADF)	22
	Using the scanner glass	23
4	Sending a fax	25
	How to send a fax	25
	Faxing A4 size documents from the scanner glass	26
	Canceling a fax in progress	26
	Transmission verification report	26

5	Receiving a fax	27
	Receive modes	27
	Choose the correct Receive Mode	27
	Using receive modes	29
	Fax Only	29
	Fax/Tel.....	29
	Manual.....	29
	External TAD	29
	Receive Mode settings	30
	Ring Delay	30
	F/T Ring Time (Fax/Tel mode only).....	30
	Easy Receive.....	31
6	Telephone services and external devices	32
	Telephone line services	32
	Voice Mail	32
	Distinctive Ring.....	32
	Connecting an external TAD (telephone answering device).....	35
	Connections.....	35
	Recording an outgoing message (OGM).....	36
	Multi-line connections (PBX)	36
	External and extension telephones.....	36
	Connecting an external or extension telephone	36
	Using external and extension telephones	37
	Using a non-Brother cordless external handset	37
	Using Remote Codes	38
7	Dialing and storing numbers	39
	How to dial	39
	Manual dialing	39
	One touch dialing.....	39
	Speed Dialing	39
	Search	40
	Fax redial	40
	Storing numbers	40
	One Touch and Speed Dial Options	41
	Storing a pause	42
	Storing One Touch Dial numbers	42
	Storing Speed Dial numbers.....	44
	Changing One Touch and Speed Dial numbers.....	46
	Deleting One Touch and Speed Dial numbers	47
8	Making copies	48
	How to copy	48
	Stop copying.....	48
	Copy settings.....	48

9	How to print from a computer	49
	Printing a document.....	49
10	How to scan to a computer	50
	Scanning a document.....	50
	Scanning using the scan key.....	50
	Scanning using a scanner driver.....	51
A	Routine maintenance	52
	Replacing the consumable items.....	52
	Replacing the toner cartridge.....	53
	Cleaning the corona wire.....	58
	Replacing the drum unit.....	59
B	Troubleshooting	64
	Error and maintenance messages.....	64
	Transferring your faxes or Fax Journal report.....	69
	Document Jams.....	70
	Document is jammed in the top of the ADF unit.....	70
	Document is jammed under the document cover.....	70
	Removing small documents jammed in the ADF.....	71
	Document is jammed at the output tray.....	71
	Paper Jams.....	72
	Paper is jammed in the standard paper tray.....	72
	Paper is jammed at the back of the machine.....	73
	Paper is jammed inside the machine.....	75
	Paper is jammed in the Duplex Tray (MFC-7460DN and MFC-7860DW).....	80
	If you are having difficulty with your machine.....	82
	Setting Dial Tone detection.....	91
	Telephone line interference.....	91
	Improving the print quality.....	92
	Machine Information.....	102
	Checking the Serial Number.....	102
	Reset functions.....	102
	How to reset the machine.....	103
C	Menu and features	104
	On-screen programming.....	104
	Menu table.....	104
	How to access the menu mode.....	104
	Menu table.....	105
	Entering text.....	122
E	Index	137

D Specifications

124

General	124
Document Size	126
Print media.....	127
Fax.....	128
Copy	129
Scanner	130
Printer	131
Interfaces	132
Computer requirements	133
Consumable items	135
Network (LAN)	136

Table of Contents

(ADVANCED USER'S GUIDE)

The Advanced User's Guide explains the following features and operations. You can view the Advanced User's Guide on the Documentation CD-ROM.

1 General Setup

Memory Storage
Volume settings
Automatic daylight savings time
Ecology features
Toner Settings
LCD Contrast
Dial Prefix
Mode Timer

2 Security features

Security

3 Sending a fax

Additional sending options
Additional sending operations
Polling overview

4 Receiving a fax

Remote Fax Options
Additional receiving operations
Polling overview

5 Dialing and storing numbers

Telephone line services
Additional dialing operations
Additional ways to store numbers

6 Printing reports

Fax reports
Reports

7 Making copies

Copy settings
Duplex Copying (1-sided to 2-sided)
(For MFC-7460DN and MFC-7860DW)

A Routine maintenance

Cleaning the machine
Checking the machine
Packing and shipping the machine

B Glossary

C Index

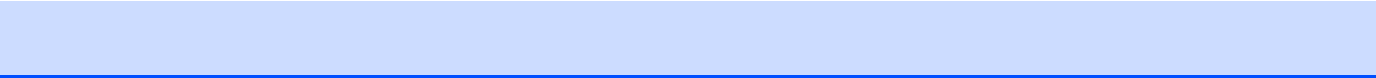

Using the documentation

Thank you for buying a Brother machine! Reading the documentation will help you make the most of your machine.

Symbols and conventions used in the documentation

The following symbols and conventions are used throughout the documentation.

Bold	Bold style identifies keys on the machine control panel or computer screen.
<i>Italics</i>	Italicized style emphasizes an important point or refers you to a related topic.
Courier New	Courier New font identifies the messages shown on the LCD of the machine.

WARNING

WARNING indicates a potentially hazardous situation which, if not avoided, could result in death or serious injuries.

CAUTION

CAUTION indicates a potentially hazardous situation which, if not avoided, may result in minor or moderate injuries.

IMPORTANT

IMPORTANT indicates a potentially hazardous situation which, if not avoided, may result in damage to property or loss of product functionality.



Electrical Hazard icons alert you to a possible electrical shock.



Hot Surface icons warn you not to touch machine parts that are hot.



Notes tell you how you should respond to a situation that may arise or give tips about how the current operation works with other features.

Accessing the Advanced User's Guide, Software User's Guide and Network User's Guide

This Basic User's Guide does not contain all the information about the machine such as how to use the advanced features for Fax, Copy, Printer, Scanner, PC-Fax and Network. When you are ready to learn detailed information about these operations, read the **Advanced User's Guide**, **Software User's Guide**, **Network Glossary**, and **Network User's Guide** that are on the Documentation CD-ROM.

Viewing Documentation

- 1 Turn on your computer. Insert the Documentation CD-ROM into your CD-ROM drive. For Windows® users, go to step 3.



Note

(Windows® users) If the screen does not appear automatically, go to **My Computer (Computer)**, double-click the CD-ROM icon, and then double-click **index.html**.

- 2 (Macintosh users) Double-click the Documentation CD-ROM icon, and then double-click **index.html**.

- 3 Click your country.

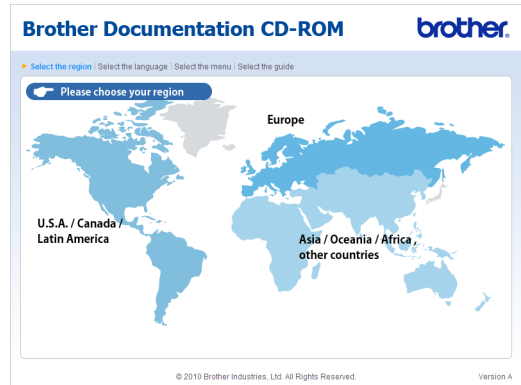

- 4 Point to your language, point to **View Guide**, and then click the guide you want to read.



**Note**

- (Windows® users only) Your Web browser may display a yellow bar at the top of the page that contains a security warning about Active X controls. For the page to display correctly you must click on the bar, click **Allow Blocked Content**, then click **Yes** in the Security Warning dialog box.
- (Windows® users only) ¹ For faster access, you can copy all user documentation in PDF format to a local folder on your computer. Point to your language, then click **Copy to local disk**.

¹ Microsoft® Internet Explorer® 6.0 or greater.

How to find Scanning instructions

There are several ways you can scan documents. You can find the instructions as follows:

Software User's Guide

- *Scanning*
- *ControlCenter*
- *Network Scanning*

ScanSoft™ PaperPort™ 12SE with OCR How-to-Guides**(Windows®)**

- The complete ScanSoft™ PaperPort™ 12SE with OCR How-to-Guides can be viewed from the Help selection in the ScanSoft™ PaperPort™ 12SE application.

Presto! PageManager User's Guide**(Macintosh)****Note**

Presto! PageManager is available as a download from http://nj.newsoft.com.tw/download/brother/PM9SEInstaller_BR_multilang.dmg/

- The complete Presto! PageManager User's Guide can be viewed from the Help selection in the Presto! PageManager application.

How to find Network setup instructions

Your machine can be connected to a wireless or wired network. You can find basic setup instructions in the *Quick Setup Guide*. If your wireless access point or router supports Wi-Fi Protected Setup or AOSS™, you can also follow the steps in the *Quick Setup Guide*. For more information about network setup, please see the *Network User's Guide*.

Accessing Brother Support (Windows®)

You can find all the contacts you will need, such as Web support (Brother Solutions Center), Customer Service and Brother Authorized Service Centers in *Brother numbers* on page i and on the Installation CD-ROM.

- Click **Brother Support** on the main menu. The following screen will appear:

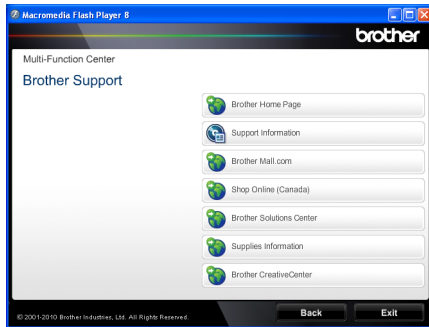

- To access our Web site (<http://www.brother.com/>) click **Brother Home Page**.
- To view all Brother Numbers, including Customer Service numbers for the USA and Canada, click **Support Information**.
- To access the USA Brother online shopping mall (<http://www.brothermall.com/>) for additional product and service information, click **Brother Mall.com**.
- To access Canada's Brother online shopping mall (<http://www.brother.ca/>) for additional product and services information, click **Shop Online (Canada)**.
- For the latest news and product support information (<http://solutions.brother.com/>), click **Brother Solutions Center**.

- To visit our Web site for genuine Brother supplies (<http://www.brother.com/original/>), click **Supplies Information**.
- To access the Brother CreativeCenter (<http://www.brother.com/creativecenter/>) for FREE photo projects and printable downloads, click **Brother CreativeCenter**.

To return to the main page, click **Back**.

Or, if you have finished, click **Exit**.

Accessing Brother Support (Macintosh)

You can find all the contacts you will need, such as Web support (Brother Solutions Center), Customer Service and Brother Authorized Service Centers in *Brother numbers* on page i and on the Installation CD-ROM.

- Double-click the **Brother Support** icon. The following screen will appear:

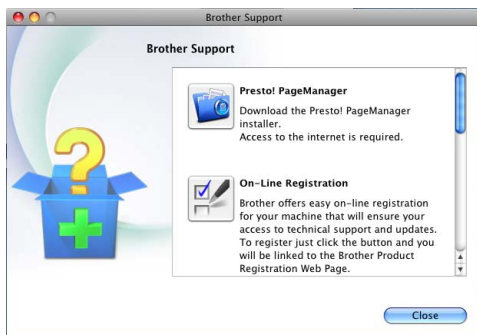

- To download and install Presto! PageManager, click **Presto! PageManager**.
- To register your machine from the Brother Product Register Page (<http://www.brother.com/registration/>), click **On-Line Registration**.
- To view all Brother Numbers, including Customer Service numbers for the USA and Canada, click **Support Information**.
- For the latest news and product support information (<http://solutions.brother.com/>), click **Brother Solutions Center**.
- To visit our Web site for genuine Brother Supplies (<http://www.brother.com/original/>), click **Supplies Information**.

Control panel overview

MFC-7460DN and MFC-7860DW have the same keys.

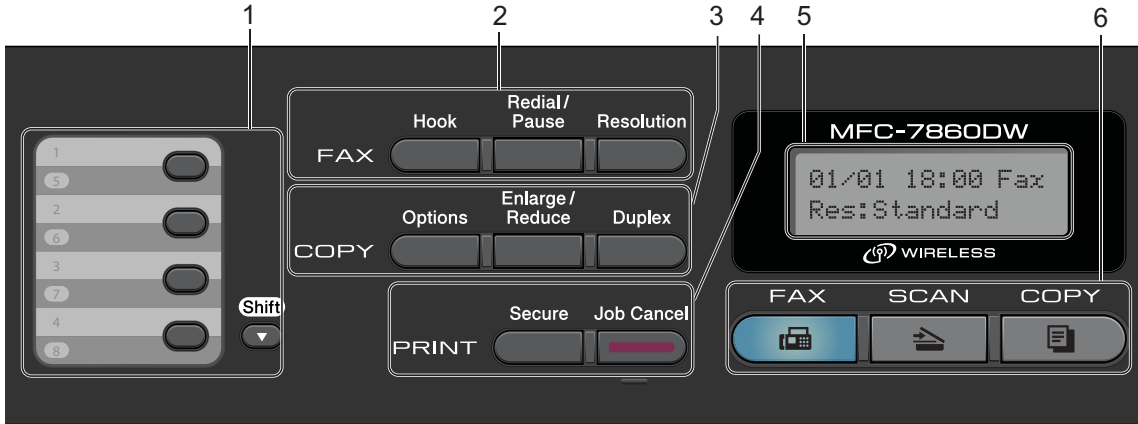

MFC-7360N

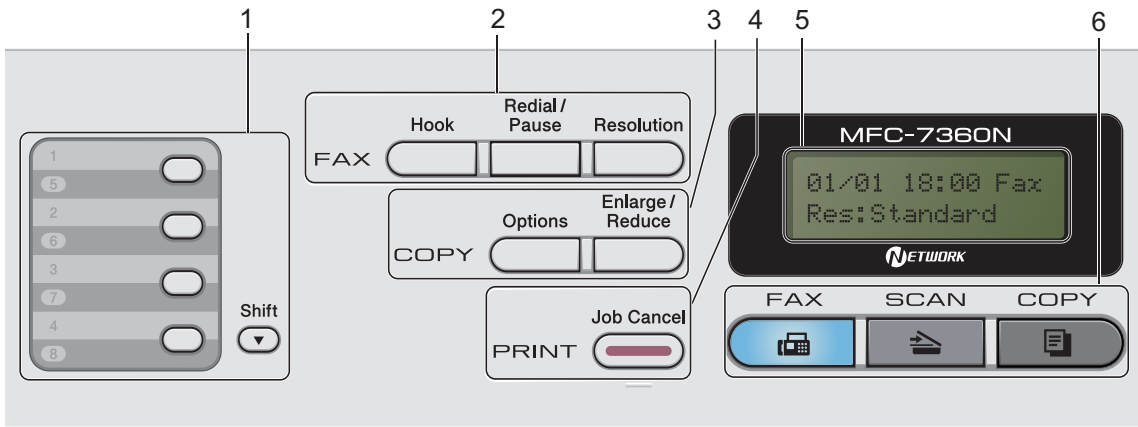

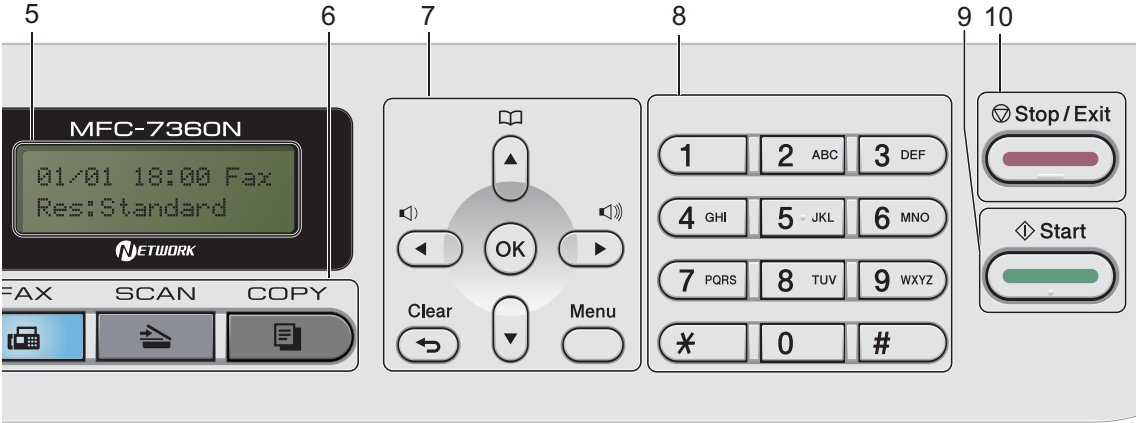
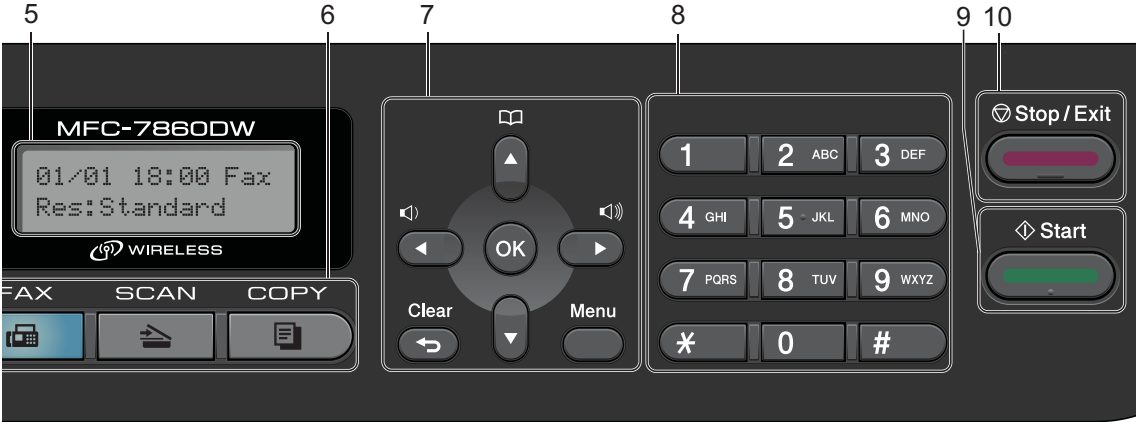

1 One Touch keys

These 4 keys give you instant access to 8 previously stored numbers.

Shift

Lets you access One Touch numbers 5 to 8 when held down.

2 FAX keys:**Hook**

Press before dialing if you want to make sure a fax machine will answer, and then press **Start**. Also, press this key after you pick up the handset of an external telephone during the F/T ring (pseudo double-rings).

Redial/Pause

Redials the last number called. It also inserts a pause when programming quick dial numbers or when dialing a number manually.

Resolution

Sets the resolution when sending a fax.

3 COPY keys:**Options**

You can quickly and easily choose temporary settings for copying.

Enlarge/Reduce

Reduces or enlarges copies.

Duplex

(For MFC-7460DN and MFC-7860DW)

You can choose Duplex to copy on both sides of the paper.

4 PRINT keys:**Secure**

(For MFC-7460DN and MFC-7860DW)

You can print data saved in the memory when you enter your four-digit password. (For details about using the Secure key, see the *Software User's Guide*.)

When using Secure Function Lock, you can switch restricted users by holding down **Shift** as you press **Secure**. (See *Secure Function Lock 2.0* in *Chapter 2* of the *Advanced User's Guide*.)

Job Cancel

Cancels a programmed print job and clears it from the machine's memory. To cancel multiple print jobs, hold down this key until the LCD shows *Job Cancel (All)*.

5 LCD

Displays messages to help you set up and use your machine.

(MFC-7860DW)

In FAX mode and SCAN mode a four level indicator shows the current wireless signal strength if you are using a wireless connection.

**6 Mode keys:****FAX**

Puts the machine in Fax mode.

**SCAN**

Puts the machine in Scan mode.

**COPY**

Puts the machine in Copy mode.

7 Menu keys:**Clear**

Deletes entered data or lets you cancel the current setting.

Menu

Lets you access the Menu to program your settings in this machine.

OK

Lets you store your settings in the machine.

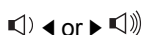
Volume keys:

Press to scroll backwards or forwards through menu selections. Press to change the volume when in fax or standby mode.



Press to scroll through the menus and options.

**▲ Address Book**

Let you access speed dial numbers directly.

8 Dial pad

Use these keys to dial telephone and fax numbers and as a keyboard for entering information into the machine.

(Canada only) The # key temporarily switches the dialing mode from Pulse to Tone during a telephone call.

9 Start:

Lets you start sending faxes or making copies.

10 Stop/Exit

Stops an operation or exits from a menu.

Loading paper and print media

The machine can feed paper from the standard paper tray or manual feed slot.

When you put paper into the paper tray, note the following:

- If your application software supports paper size selection on the print menu, you can select it through the software. If your application software does not support it, you can set the paper size in the printer driver or by using the control panel buttons.

Loading paper in the standard paper tray

You can load up to 250 sheets. Paper can be loaded up to the maximum paper mark (▼▼▼) on the sliding paper with guide. (For recommended paper to use, see *Paper capacity of the paper trays* on page 18.)

Printing on plain paper, thin paper or recycled paper from the standard paper tray

- 1 Pull the paper tray completely out of the machine.

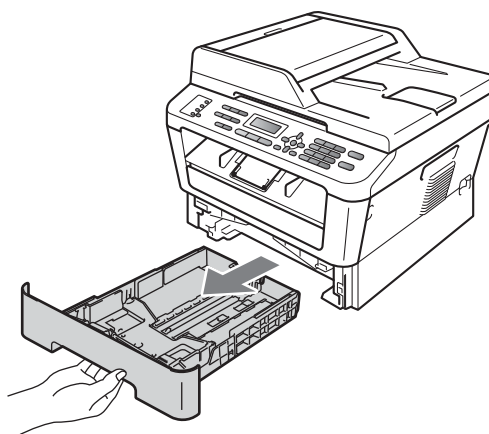

- 2 While pressing the green paper-guide release lever, slide the paper guides to fit the paper size you are loading in the tray. Make sure that the guides are firmly in the slots.

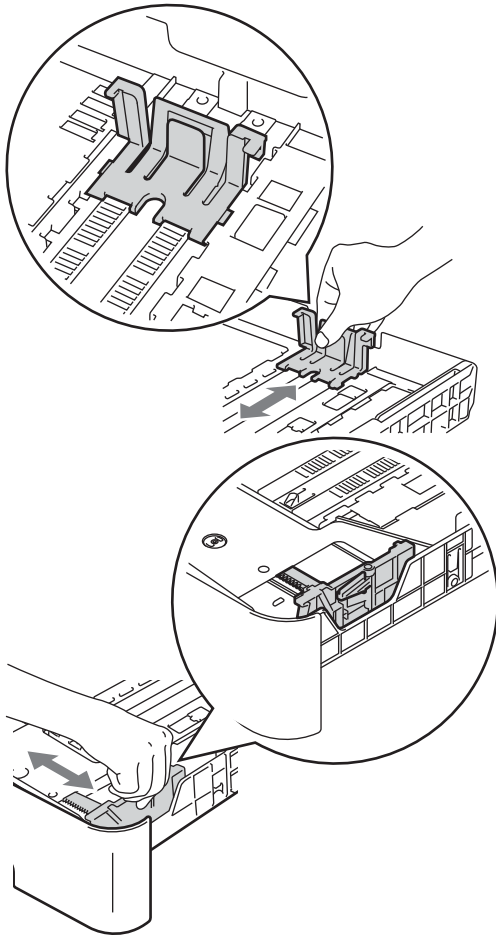

 **Note**

For Legal or Folio size paper, press the release button in the bottom of the paper tray and then pull out the back of the paper tray. (Legal or Folio size paper is not available in some regions.)

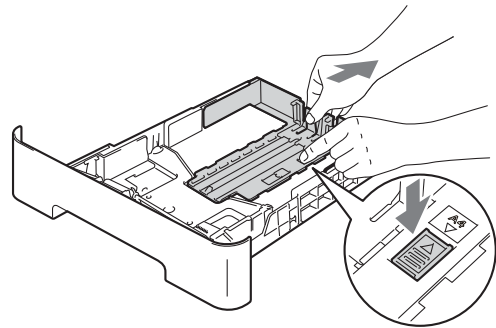

- 3 Fan the stack of paper well to avoid paper jams and misfeeds.

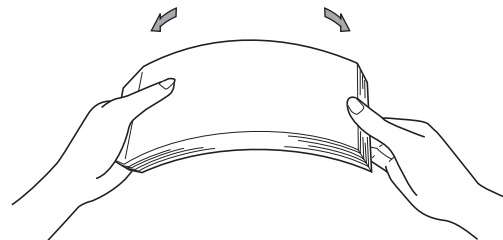

- 4 Put paper in the tray and make sure:
 - The paper is below the maximum paper mark (▼▼▼) (1).
Overfilling the paper tray will cause paper jams.
 - The side to be printed on must be *face down*.
 - The paper guides touch the sides of the paper so it will feed properly.

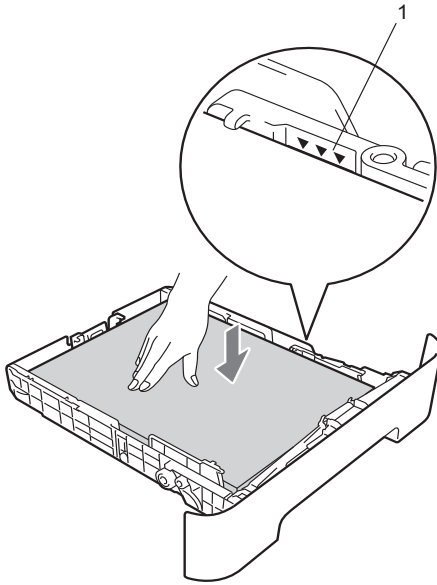

- 5 Put the paper tray firmly back in the machine. Make sure that it is completely inserted into the machine.
- 6 Unfold the support flap (1) to prevent paper from sliding off the face-down output tray.

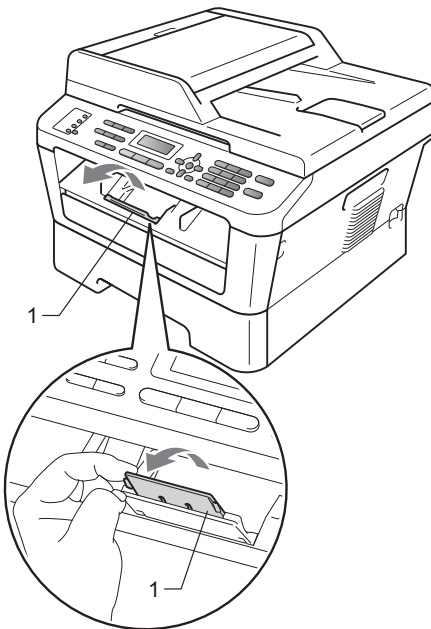

Loading paper in the manual feed slot

You can load envelopes and special print media one at a time into this slot. Use the manual feed slot to print or copy on labels, envelopes or thicker paper.



Note

The machine automatically turns on the Manual Feed mode when you put paper in the manual feed slot.

Printing on plain paper, thin paper or recycled paper from the manual feed slot

- 1 Unfold the support flap (1) to prevent paper from sliding off the face-down output tray, or remove each page as soon as it comes out of the machine.

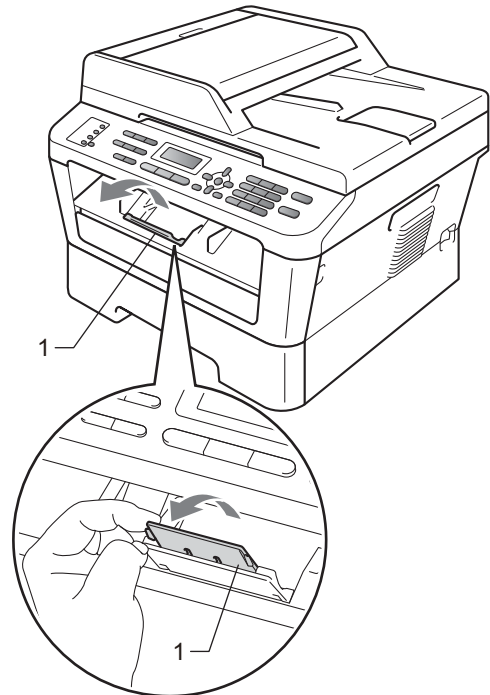

- 2 Open the manual feed slot cover.

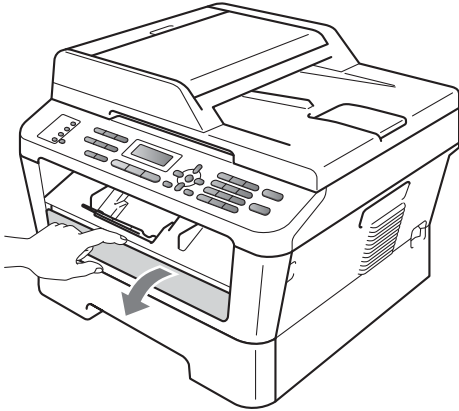

- 3 Using both hands, slide the manual feed slot paper guides to the width of the paper that you are going to use.

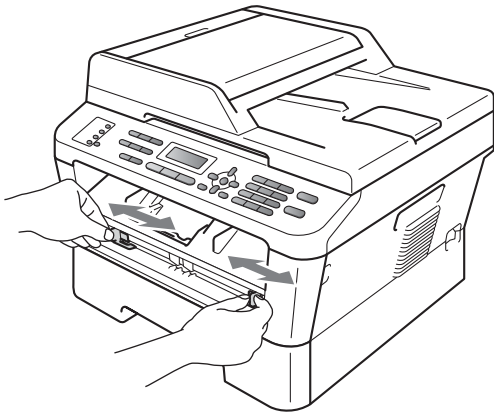

- 4 Using both hands, put one sheet of paper in the manual feed slot until the front edge of the paper touches the paper feed roller. When you feel the machine pull in the paper, let go.

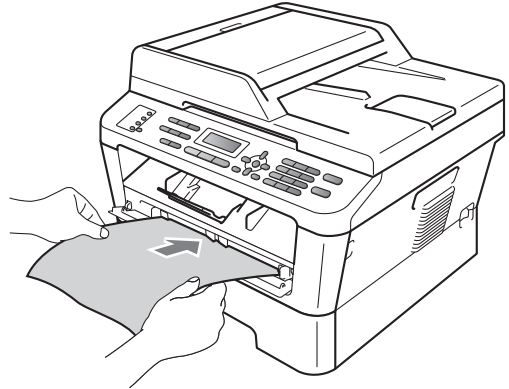

Printing on thick paper, bond paper, labels and envelopes

When the back output tray is pulled down, the machine has a straight paper path from the manual feed slot through to the back of the machine. Use this paper feed and output method when you want to print on thick paper, labels or envelopes.



Note

Remove each printed sheet or envelope immediately to prevent a paper jam.

- 1 Open the back cover (back output tray).

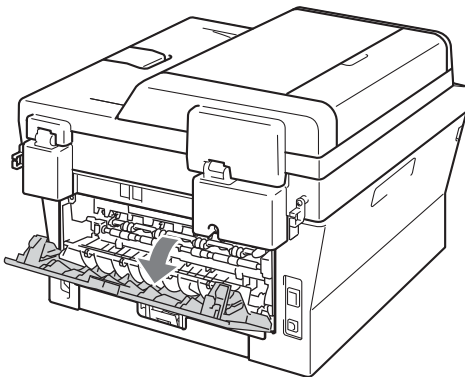
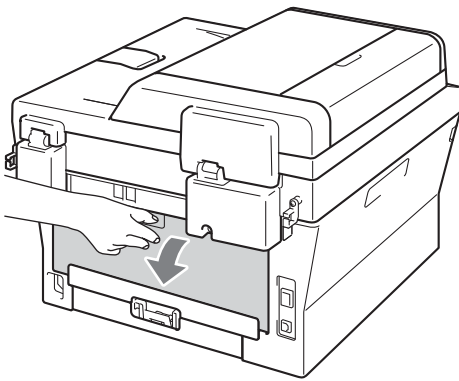

Note

<For envelopes only>

Pull down the two green levers, one on the left-hand side and one on the right-hand side, as shown in the following illustration.

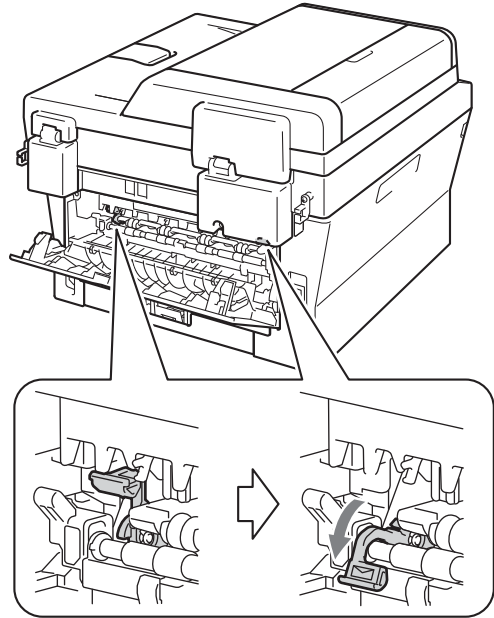

- 2 Open the manual feed slot cover.

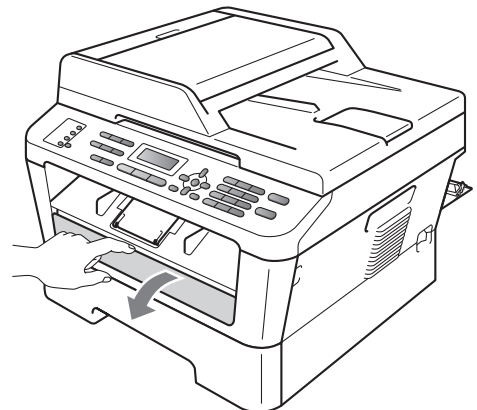

- 3 Using both hands, slide the manual feed slot paper guides to the width of the paper that you are going to use.

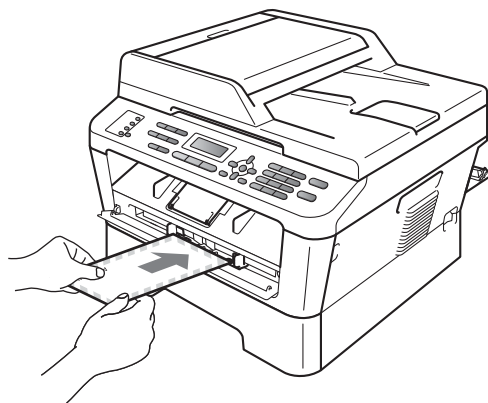
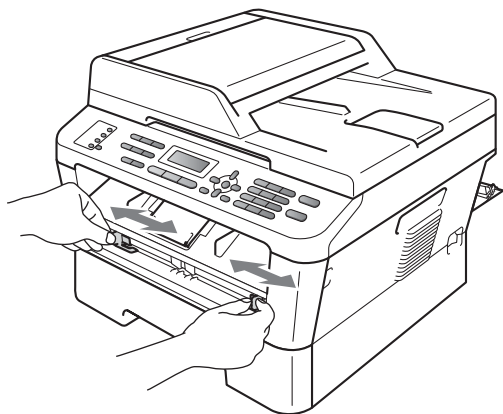

- 4 Using both hands, put one sheet of paper or one envelope in the manual feed slot until the front edge of the paper or envelope touches the paper feed roller. When you feel the machine pull in the paper, let go.

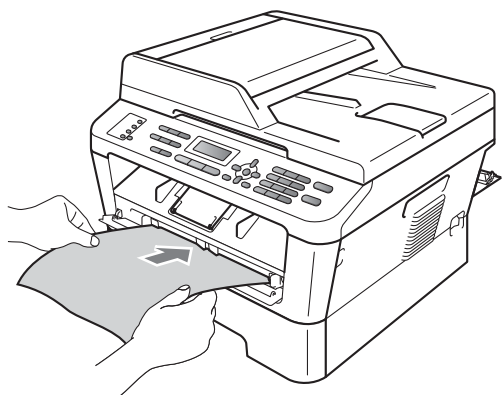

 **Note**

- Put the paper into the manual feed slot with the side to be printed face up.
- Make sure that the print media is straight and in the proper position on the manual feed slot. If it is not, the paper may not be fed properly, resulting in a skewed printout or a paper jam.
- Do not put more than one sheet of paper in the manual feed slot at any one time, as it may cause a jam.
- If you put any print media in the manual feed slot before the machine is in Ready mode, the print media may be ejected without being printed on.
- To easily remove a small printout from the output tray, lift up the scanner cover by using both hands as shown in the illustration.

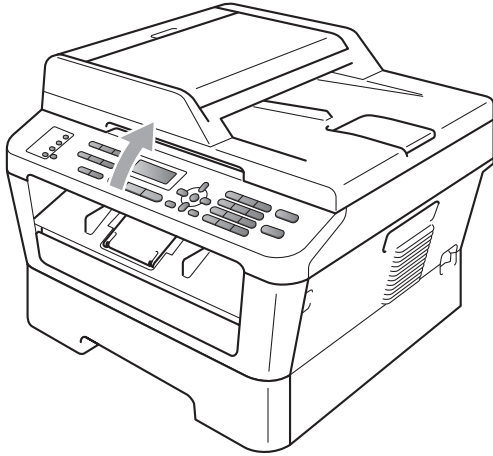

- You can still use the machine while the scanner cover is up. To close the scanner cover, push it down with both hands.

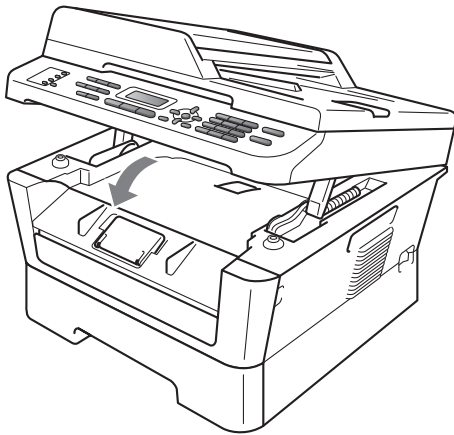

Unscannable and unprintable areas

The figures below show maximum unscannable and unprintable areas. The unscannable and unprintable areas may vary depending on the paper size or settings in the application you are using.

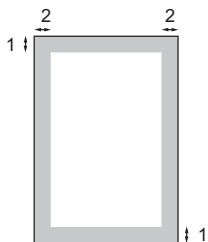

Usage	Document Size	Top (1) Bottom (1)	Left (2) Right (2)
Fax (Send)	Letter	0.12 in. (3 mm)	0.16 in. (4 mm)
	A4	0.12 in. (3 mm)	0.12 in. (3 mm)
Copy *a single copy or a 1 in 1 copy	Letter	0.16 in. (4 mm)	0.16 in. (4 mm)
	A4	0.16 in. (4 mm)	0.16 in. (4 mm)
Scan	Letter	0.12 in. (3 mm)	0.12 in. (3 mm)
	A4	0.12 in. (3 mm)	0.12 in. (3 mm)
Print	Letter	0.24 in. (6 mm)	0.24 in. (6 mm)
	A4	0.24 in. (6 mm)	0.24 in. (6 mm)

Paper settings

Paper Type

Set up the machine for the type of paper you are using. This will give you the best print quality.

- 1 Press **Menu**, **1**, **2**, **1**.

Paper
1. Paper Type

- 2 Press **▲** or **▼** to choose **Thin**, **Plain**, **Thick**, **Thicker**, **Recycled Paper** or **Label**.
Press **OK**.

- 3 Press **Stop/Exit**.

Paper Size

You can use several different sizes of paper for printing copies: Letter, Legal, Executive, A4, A5, A5L, A6, B5, B6, and Folio (8.5 in. x 13 in.).

When you change the size of paper in the tray, you will also need to change the setting for paper size at the same time so your machine can fit the document or an incoming fax on the page.

- 1 Press **Menu**, **1**, **2**, **2**.

Paper
2. Paper Size

- 2 Press **▲** or **▼** to choose **A4**, **Letter**, **Legal**, **Executive**, **A5**, **A5 L**, **A6**, **B5**, **B6**, or **Folio**.
Press **OK**.

- 3 Press **Stop/Exit**.

Acceptable paper and other print media

Print quality may vary according to the type of paper you are using.

You can use the following types of print media: thin paper, plain paper, thick paper, bond paper, recycled paper, labels or envelopes.

For best results, follow the instructions below:

- DO NOT put different types of paper in the paper tray at the same time because it may cause paper jams or misfeeds.
- For proper printing, you must choose the same paper size from your software application as the paper in the tray.
- Avoid touching the printed surface of the paper immediately after printing.
- Before you buy a lot of paper, test a small quantity to make sure the paper is suitable.

Recommended paper and print media

Paper Type	Item
Plain Paper	Xerox 4200DP 20 lb
	Hammermill Laser Print (24 lb=90 g/m ²)
Recycled Paper	No specific brand recommended
Labels	Avery laser labels white #5160
Envelope	No specific brand recommended

Type and size of paper

The machine loads paper from the installed standard paper tray or manual feed slot.

The name for the paper trays in the printer driver in this Guide are as follows:

Tray and optional unit	Name
Standard paper tray	Tray 1
Manual feed slot	Manual

Paper capacity of the paper trays

	Paper size	Paper types	No. of sheets
Paper Tray (Tray 1)	A4, Letter, B5, Executive, A5, A5 (Long Edge), A6, B6, Folio ^{1 2} , Legal ²	Plain paper, Thin paper and Recycled paper	up to 250 [20 lb (80 g/m ²)]
Manual feed slot (Manual)	Width: 3 to 8.5 in. (76.2 to 216 mm) Length: 4.6 to 16 in. (116 to 406.4 mm)	Plain paper, Thin paper, Thick paper, Bond paper, Recycled paper, Envelopes and Labels	Single sheet [20 lb (80 g/m ²)]

¹ Folio size is 8.5 in. × 13 in. (215.9 mm × 330.2 mm)

² Legal or Folio size paper is not available in some regions outside the USA and Canada.

Recommended paper specifications

The following paper specifications are suitable for this machine.

Basis weight	20-24 lb (75-90 g/m ²)
Thickness	80-110 μm
Roughness	Higher than 20 sec.
Stiffness	90-150 cm ³ /100
Grain direction	Long grain
Volume resistivity	10e ⁹ -10e ¹¹ ohm
Surface resistivity	10e ⁹ -10e ¹² ohm-cm
Filler	CaCO ₃ (Neutral)
Ash content	Below 23 wt%
Brightness	Higher than 80%
Opacity	Higher than 85%

- Use paper made for plain paper copying.
- Use paper that is 20 to 24 lb (75 to 90 g/m²).
- Use long grain paper with a neutral Ph value, and a moisture content of approx. 5%.
- This machine can use recycled paper that meets DIN 19309 specifications.

Handling and using special paper

The machine is designed to work well with most types of xerographic and bond paper. However, some paper variables may have an effect on print quality or handling reliability. Always test samples of paper before purchasing to ensure desirable performance. Store paper in its original packaging and keep it sealed. Keep the paper flat and away from moisture, direct sunlight and heat.

Some important guidelines when selecting paper are:

- DO NOT use inkjet paper because it may cause a paper jam or damage your machine.
- Preprinted paper must use ink that can withstand the temperature of the machine's fusing process 392 degrees Fahrenheit (200 degrees centigrade).
- If you use bond paper, paper having a rough surface or paper that is wrinkled or creased, the paper may exhibit degraded performance.

Types of paper to avoid

! IMPORTANT

Some types of paper may not perform well or may cause damage to your machine.

DO NOT use paper:

- that is highly textured
- that is extremely smooth or shiny
- that is curled or warped

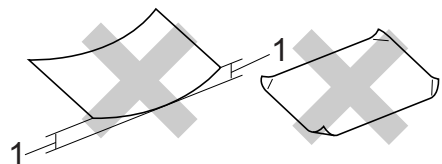

1 A curl of 0.08 in. (2 mm) or greater may cause jams to occur.

- that is coated or has a chemical finish
- that is damaged, creased or folded
- that exceeds the recommended weight specification in this guide
- with tabs and staples
- with letterheads using low temperature dyes or thermography
- that is multipart or carbonless
- that is designed for inkjet printing

If you use any of the types of paper listed above, they may damage your machine. This damage is not covered under any Brother warranty or service agreement.

Envelopes

Most envelopes designed for laser printers will be suitable for your machine. However, some envelopes may have feed and print-quality problems because of the way they have been made. A suitable envelope should have edges with straight, well-creased folds and the leading edge should not be thicker than two sheets of paper. The envelope should lie flat and not be of baggy or flimsy construction. You should buy quality envelopes from a supplier who understands that you will be using the envelopes in a laser machine.

Envelopes can be fed from the manual feed slot one at a time. We recommend that you print a test envelope to make sure the print results are what you want before you print or purchase a large quantity of envelopes.

Types of envelopes to avoid

! IMPORTANT

DO NOT use envelopes:

- that are damaged, curled, wrinkled or an unusual shape
- that are extremely shiny or textured
- with clasps, staples, snaps or tie strings
- with self-adhesive closures
- that are of a baggy construction
- that are not sharply creased
- that are embossed (have raised writing on them)
- that were previously printed by a laser machine
- that are pre-printed on the inside
- that cannot be arranged neatly when stacked
- that are made of paper that weighs more than the paper weight specifications for the machine

- with edges that are not straight or consistently square
- with windows, holes, cut-outs or perforations
- with glue on surface as shown in figure below

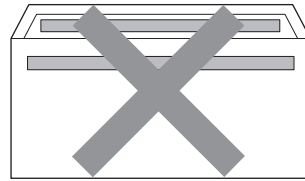

- with double flaps as shown in figure below

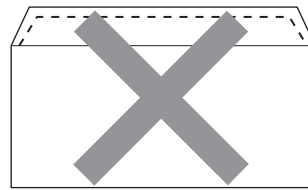

- with sealing flaps that are not folded down when purchased
- with sealing flaps as shown in figure below

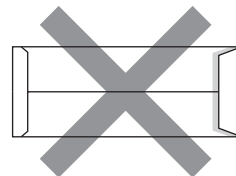

- with each side folded as shown in figure below

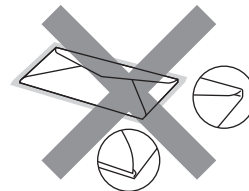

If you use any of the types of envelopes listed above, they may damage your machine. This damage may not be covered under any Brother warranty or service agreement.

Labels

The machine will print on most types of labels designed for use with a laser machine. Labels should have an adhesive that is acrylic-based since this material is more stable at the high temperatures in the fuser unit. Adhesives should not come in contact with any part of the machine, because the label stock may stick to the drum unit or rollers and cause jams and print quality problems. No adhesive should be exposed between the labels. Labels should be arranged so that they cover the entire length and width of the sheet. Using labels with spaces may result in labels peeling off and causing serious jams or print problems.

All labels used in this machine must be able to withstand a temperature of 392 degrees Fahrenheit (200 degrees centigrade) for a period of 0.1 seconds.

Do not feed a label sheet through the machine more than one time.

Types of labels to avoid

Do not use labels that are damaged, curled, wrinkled or an unusual shape.

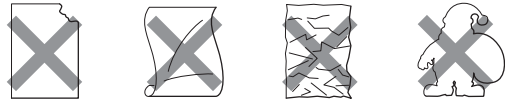

! IMPORTANT

- Avoid feeding labels with the carrier sheet exposed because your machine will be damaged.
- Label sheets should not exceed the paper weight specifications described in this User's Guide. Labels exceeding this specification may not feed or print properly and may cause damage to your machine.
- DO NOT reuse or insert labels that have previously been used or are missing few labels on the sheet.

3

Loading documents

How to load documents

You can send a fax, make copies, and scan from the ADF (Automatic Document Feeder) and the scanner glass.

Using the automatic document feeder (ADF)

The ADF can hold up to 35 pages and feeds each sheet individually. Use standard 20 lb (80 g/m²) paper and always fan the pages before putting them in the ADF.

Document Sizes Supported

Length:	5.8 to 14 in. (147.3 to 355.6 mm)
Width:	5.8 to 8.5 in. (147.3 to 215.9 mm)
Weight:	17 to 24 lb (64 to 90 g/m ²)

! IMPORTANT

- DO NOT use paper that is curled, wrinkled, folded, ripped, stapled, paper-clipped, pasted or taped.
- DO NOT use cardboard, newspaper or fabric.
- To avoid damaging your machine while using the ADF, DO NOT pull on the document while it is feeding.

Note

- To scan documents that are not suitable for the ADF, see *Using the scanner glass* on page 23.
- It is easier to use the ADF if you are loading a multiple page document.
- Make sure documents with correction fluid or written with ink are completely dry.

How to load documents

- 1 Lift up and unfold the ADF document output support flap (1). Unfold the ADF document support (2).

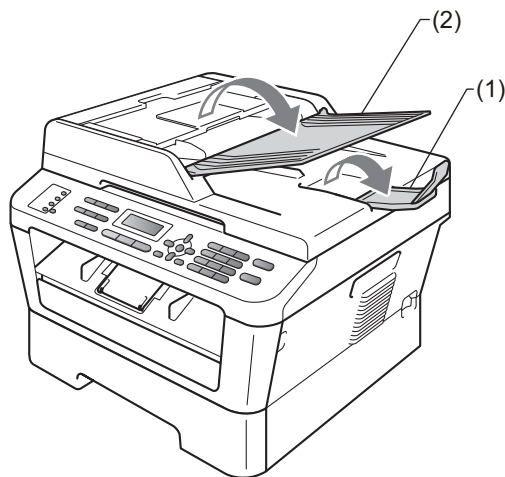

- 2 Fan the pages well.

- 3 Stagger the pages of your document *face up top edge first*, in the ADF until the LCD display message changes and you feel it touch the feed rollers.

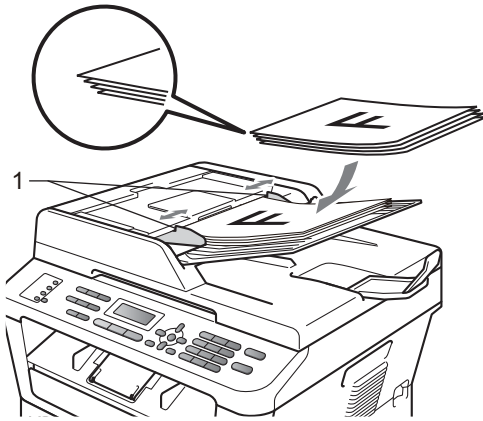

- 4 Adjust the paper guides (1) to fit the width of your document.

! IMPORTANT

To avoid damaging your machine while using the ADF, **DO NOT** pull on the document while it is feeding.

Using the scanner glass

You can use the scanner glass to fax, copy or scan pages of a book one page at a time.

Document Sizes Supported

Length:	Up to 11.7 in. (297 mm)
Width:	Up to 8.5 in. (215.9 mm)
Weight:	Up to 4.4 lb (2 kg)

! IMPORTANT

DO NOT leave thick documents on the scanner glass. If you do this, the ADF may jam.

How to load documents



Note

To use the scanner glass, the ADF must be empty.

- 1 Lift the document cover.
- 2 Using the document guidelines on the left and top, place the document *face down* in the upper left corner of the scanner glass.

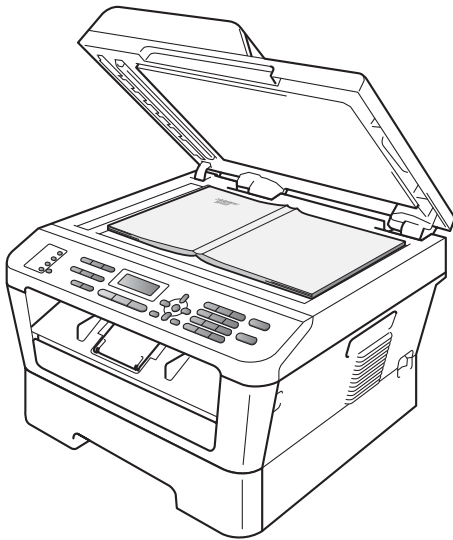
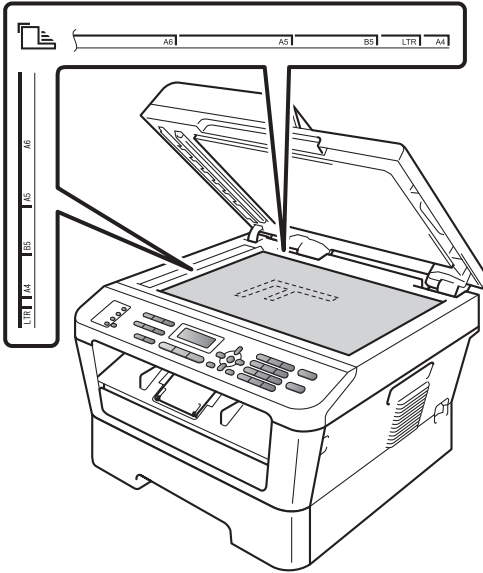

- 3 Close the document cover.

! IMPORTANT

If the document is a book or is thick do not slam the cover or press on it.

4

Sending a fax

How to send a fax

The following steps show how to send a fax.

- 1 When you want to send a fax, or change fax send or receive settings, press the  (FAX) key to illuminate it in blue.

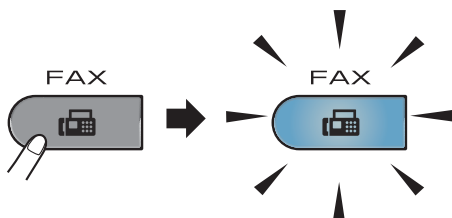

- 2 Do one of the following to load your document:
 - Place the document *face up* in the ADF. (See *Using the automatic document feeder (ADF)* on page 22.)
 - Load your document *face down* on the scanner glass. (See *Using the scanner glass* on page 23.)

- 3 Set the scanner glass size, fax resolution or contrast if you want to change them.
For more advanced fax sending operations and settings, see *Sending a fax* in *Chapter 3 of the Advanced User's Guide*:

- Broadcast
- Delayed Fax
- Batch TX
- Real Time TX
- Polled TX
- Overseas Mode
- Fax Resolution
- Contrast
- Coverpg Setup
- Coverpage Msg

- 4 Enter the fax number using the dial pad, a One touch key or  (Address Book) and enter three-digit number.

- 5 Press **Start**.

Faxing from the ADF

- The machine starts scanning the document.

Faxing from the scanner glass

- If you press **Start**, the machine starts scanning the first page.

Do one of the following:

- To send a single page, press **2** to choose **No (Send)** (or press **Start** again). The machine starts sending the document.
- To send more than one page, press **1** to choose **Yes** and place the next page on the scanner glass. Press **OK**. The machine starts scanning the page. (Repeat this step for each additional page.)
If you press **Start**, the machine starts sending the document.



Note

To cancel, press **Stop/Exit**.

Faxing A4 size documents from the scanner glass

When faxing A4 size documents, you will need to set the scan glass size to A4; otherwise, a portion of your faxes will be missing.

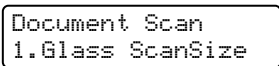
- 1 Make sure you are in Fax mode .
- 2 (MFC-7360N)
Press **Menu**, **1**, **7**.
(MFC-7460DN and MFC-7860DW)
Press **Menu**, **1**, **7**, **1**.

- 3 Press **▲** or **▼** to choose A4.
Press **OK**.
- 4 Press **Stop/Exit**.

Canceling a fax in progress

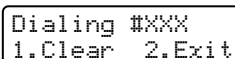
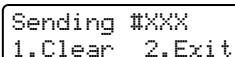
Press **Stop/Exit** to cancel the fax. If you press **Stop/Exit** while the machine is dialing or sending, the LCD will show as below:

Press **1** to cancel the fax.

Transmission verification report

You can use the Transmission Verification Report as proof that you sent a fax. This report lists the receiving party's name or fax number, the time and date of transmission, duration of transmission, number of pages sent, and whether or not the transmission was successful.

There are several settings available for the Transmission Verification Report:

- **On**: Prints a report after every fax you send.
- **On+Image**: Prints a report after every fax you send. A portion of the fax's first page appears on the report.
- **Off**: Prints a report if your fax is unsuccessful due to a transmission error. Off is the default setting.
- **Off+Image**: Prints a report if your fax is unsuccessful due to a transmission error. A portion of the fax's first page appears on the report.

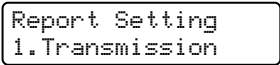
- 1 Press **Menu**, **2**, **4**, **1**.

- 2 Press **▲** or **▼** to choose On, On+Image, Off or Off+Image.
Press **OK**.
- 3 Press **Stop/Exit**.



Note

- If you choose **On+Image** or **Off+Image**, the image will only appear on the Transmission Verification Report if Real Time Transmission is set to **Off**. (See *Real Time Transmission* in Chapter 3 of the *Advanced User's Guide*.)
- If your transmission is successful, **OK** will appear next to **RESULT** on the Transmission Verification Report. If transmission is not successful, **NG** will appear next to **RESULT**.

Receive modes

Choose the correct Receive Mode

The correct Receive Mode is determined by the external devices and telephone subscriber services (Voice Mail, Distinctive Ring, etc.) you have (or will be using) on the same line as the Brother machine.

Will you be using a Distinctive Ring number for receiving faxes?

Brother uses the term 'Distinctive Ring' but different telephone companies may have other names for this service such as Custom Ringing, RingMaster, Personalized Ring, Teen Ring, Ident-A-Ring, Ident-A-Call, Data Ident-A-Call, Smart Ring and SimpleBiz Fax & Alternate Number Ringing. (See *Distinctive Ring* on page 32 for instructions on setting up your machine using this feature.)

Will you be using Voice Mail on the same telephone line as your Brother machine?

If you have Voice Mail on the same telephone line as your Brother machine, there is a strong possibility that Voice Mail and the Brother machine will conflict with each other when receiving incoming calls. (See *Voice Mail* on page 32 for instructions on setting up your machine using this service.)

Will you be using a Telephone Answering Device on the same telephone line as your Brother machine?

Your external telephone answering device (TAD) will automatically answer every call. Voice messages are stored on the external TAD and fax messages are printed. Choose `External TAD` as your receive mode. (See *Connecting an external TAD (telephone answering device)* on page 35.)

Will you be using your Brother machine on a dedicated fax line?

Your machine automatically answers every call as a fax. Choose `Fax Only` as your receive mode. (See *Fax Only* on page 29.)

Will you be using your Brother machine on the same line as your telephone?**Do you want to receive voice calls and faxes automatically?**

The `Fax/Tel` receive mode is used when sharing the Brother machine and your telephone on the same line. Choose `Fax/Tel` as your receive mode. (See *Fax/Tel* on page 29.)

Important Note: You can not receive voice messages on either Voice Mail or an answering machine when choosing the `Fax/Tel` mode.

Do you expect to receive very few faxes?

Choose `Manual` as your receive mode. You control the telephone line and must answer every call yourself. (See *Manual* on page 29.)

To set the receive mode follow the instructions below:

- 1 Press **Menu, 0, 1**.

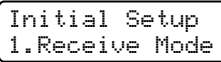

Initial Setup
1.Receive Mode

- 2 Press **▲** or **▼** to choose the receive mode.
Press **OK**.

- 3 Press **Stop/Exit**.

The LCD will display the current receive mode.

Using receive modes

Some receive modes answer automatically (*Fax Only* and *Fax/Tel*). You may want to change the *Ring Delay* before using these modes. (See *Ring Delay* on page 30.)

Fax Only

Fax Only mode will automatically answer every call as a fax.

Fax/Tel

Fax/Tel mode helps you automatically manage incoming calls, by recognizing whether they are fax or voice calls and handling them in one of the following ways:

- Faxes will be automatically received.
- Voice calls will start the *F/T* ring to tell you to pick up the line. The *F/T* ring is a fast double-ring made by your machine.

(Also see *Ring Delay* on page 30 and *F/T Ring Time (Fax/Tel mode only)* on page 30.)

Manual

Manual mode turns off all automatic answering functions unless you are using the *Distinctive Ring Receive* feature.

To receive a fax in *Manual* mode lift the handset of the external telephone or press **Hook**. When you hear fax tones (short repeating beeps), press **Start**, and then press **2** to receive a fax. You can also use the *Easy Receive* feature to receive faxes by lifting a handset on the same line as the machine.

(Also see *Easy Receive* on page 31.)

External TAD

External TAD mode lets an external answering device manage your incoming calls. Incoming calls will be handled in the following ways:

- Faxes will be automatically received.
- Voice callers can record a message on the external TAD.

(For more information, see *Connecting an external TAD (telephone answering device)* on page 35.)

Receive Mode settings

Ring Delay

The Ring Delay setting sets the number of times the machine rings before it answers in Fax Only and Fax/Tel modes.

If you have external or extension telephones on the same line as the machine, keep the Ring Delay setting of 4. (See *Easy Receive* on page 31.)

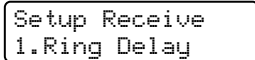
- 1 Make sure you are in Fax mode .
- 2 Press **Menu, 2, 1, 1**.

- 3 Press **▲** or **▼** to choose 00, 01, 02, 03 or 04 for how many times the line rings before the machine answers. Press **OK**.



Note

If you choose 00, the machine will answer immediately and the line will not ring at all.



- 4 Press **Stop/Exit**.

F/T Ring Time (Fax/Tel mode only)

When somebody calls your machine, you and your caller will hear the normal telephone ring sound. The number of rings is set by the Ring Delay setting.

If the call is a fax, then your machine will receive it; however, if it is a voice call the machine will sound the F/T ring (a fast double-ring) for the time you have set in the F/T Ring Time setting. If you hear the F/T ring it means that you have a voice caller on the line.

Because the F/T ring is made by the machine, extension and external telephones will *not* ring; however, you can still answer the call on any telephone. (For more information, see *Using Remote Codes* on page 38.)

- 1 Make sure you are in Fax mode .
- 2 Press **Menu, 2, 1, 2**.

- 3 Press **▲** or **▼** to choose how long the machine will ring to alert you that you have a voice call (20, 30, 40 or 70 seconds). Press **OK**.
- 4 Press **Stop/Exit**.

Easy Receive

If Easy Receive is **On**:

The machine can receive a fax automatically, even if you answer the call. When you see `Receiving` on the LCD or hear a click on the phone line through the handset you are using, just replace the handset. Your machine will do the rest.

If Easy Receive is **Off**:

If you are at the machine and answer a fax call first by lifting the external handset, then press **Start**, and then press **2** to receive.

If you answered at an extension telephone press ***51**.



Note

- If this feature is set to **On**, but your machine does not connect a fax call when you lift an extension telephone handset, press the fax receive code ***51**.
- If you send faxes from a computer on the same telephone line and the machine intercepts them, set Easy Receive to **Off**.

1 Make sure you are in Fax mode .

2 Press **Menu, 2, 1, 3**.

```
Setup Receive
3.Easy Receive
```

3 Press **▲** or **▼** to choose **On** or **Off**.
Press **OK**.

4 Press **Stop/Exit**.

Telephone line services

Voice Mail

If you have Voice Mail on the same telephone line as your Brother machine, Voice Mail and the Brother machine will conflict with each other when receiving incoming calls.

For example, if your Voice Mail is set to answer after 4 rings and your Brother machine is set to answer after 2 rings, then your Brother machine will answer first. This will prevent callers from being able to leave a message in your Voice Mail.

Similarly, if your Brother machine is set to answer after 4 rings and your Voice Mail is set to answer after 2 rings, then your Voice Mail will answer first. This will prevent your Brother machine from being able to receive an incoming fax, since Voice Mail cannot transfer the incoming fax back to the Brother machine.

To avoid conflicts between your Brother machine and your Voice Mail service, do one of the following:

Get the Distinctive Ring service from your telephone company. Distinctive Ring is a feature of your Brother machine that allows a person with one line to receive fax and voice calls through two different telephone numbers on that one line. Brother uses the term 'Distinctive Ring', but telephone companies market the service under a variety of names, such as Custom Ringing, Personalized Ring, Smart Ring, RingMaster, Ident-A-Ring, Ident-A-Call, Data Ident-A-Call,

Teen Ring, and SimpleBiz Fax & Alternate Number Ringing. This service establishes a second telephone number on the same line as your existing telephone number, and each number has its own ring pattern. Typically, the original number rings with the standard ring pattern and is used for receiving voice calls, and the second number rings with a different ring pattern and is used for receiving faxes. (See *Distinctive Ring* on page 32.)

OR

Set your Brother machine's Receive Mode to "Manual". Manual Mode requires that you answer every incoming call if you want to be able to receive a fax. If the incoming call is a telephone call, then complete the call as you normally would. If you hear fax sending tones you must transfer the call to the Brother machine. (See *Using external and extension telephones* on page 37.) Unanswered fax and voice calls will go to your Voice Mail. (To set the machine in **MANUAL** Mode, see *Choose the correct Receive Mode* on page 27.)

Distinctive Ring

Distinctive Ring is a function of your Brother machine that allows a person with one line to receive fax and voice calls through two different phone numbers on that one line. Brother uses the term 'Distinctive Ring', but telephone companies market the service under a variety of names, such as Smart Ring, Ring Master or Ident-a-Ring. This service establishes a second telephone number on the same line as your existing telephone number, and each number has its own ring pattern. Typically, the original number rings with the standard ring pattern and is used for receiving voice calls, and the second number rings with a different ring pattern and is used for receiving faxes.

**Note**

- You must pay for your telephone company's Distinctive Ring service before you program the machine to work with it.
- Please call your telephone company for availability and rates.

What does your telephone company's 'Distinctive Ring' do?

Your telephone company's Distinctive Ring service allows you to have more than one number on the same telephone line. **If you need more than one telephone number, it is cheaper than paying for an extra line.** Each telephone number has its own Distinctive Ring pattern, so you will know which telephone number is ringing. This is one way you can have a separate telephone number for your machine.

**Note**

Please call your telephone company for availability and rates.

What does Brother's 'Distinctive Ring' do?

The Brother machine has a Distinctive Ring feature that allows you to use your machine to take full advantage of the telephone company's Distinctive Ring service. The new telephone number on your line can just receive faxes.

**Note**

You must pay for your telephone company's Distinctive Ring service before you program the machine to work with it.

Do you have Voice Mail?

If you have Voice Mail on the telephone line that you will install your new machine on, *there is a strong possibility that Voice Mail and the machine will conflict with each other while receiving incoming calls.* **However, the Distinctive Ring feature allows you to use more than one number on your line, so both Voice Mail and the machine can work together without any problems.** If each one has a separate telephone number, neither will interfere with the other's operations.

If you decide to get the Distinctive Ring service from the telephone company, you will need to follow the directions below to 'register' the new Distinctive Ring pattern they give you. This is so your machine can recognize its incoming calls.

**Note**

You can change or cancel the Distinctive Ring pattern at any time. You can switch it off temporarily, and turn it back on later. When you get a new fax number, make sure you reset this feature.

Before you choose the ring pattern to register

You can only register one Distinctive Ring pattern with the machine. Some ring patterns cannot be registered. The ring patterns below are supported by your Brother machine. Register the one your telephone company gives you.

Ring Pattern	Rings	
1	long-long	
2	short-long-short	
3	short-short-long	
4	very long (normal pattern)	

Note

- Ring Pattern #1 is often called Short-Short and is the most commonly used.
 - If the ring pattern you received is not on this chart, **please call your telephone company and ask for one that is shown.**
-
- The machine will only answer calls to its registered number.
 - The first two rings are silent on the machine. This is because the fax must <<listen>> to the ring pattern (to compare it to the pattern that was 'registered'). (Other telephones on the same line will ring.)
 - If you program the machine properly, it will recognize the registered ring pattern of the 'fax number' within 2 ring patterns and then answer with a fax tone. When the 'voice number' is called, the machine will not answer.

Registering the Distinctive Ring pattern Very important!

After you have set the Distinctive Ring feature to On, your Distinctive Ring number will receive faxes automatically. The receive mode is automatically set to `Manual` and you cannot change it to another receive mode while Distinctive Ring is set to On. This ensures the Brother machine will only answer the Distinctive Ring number and not interfere when your main telephone number is called.

- 1 Press **Menu, 2, 0, 2.**

```
Miscellaneous
2.Distinctive
```

- 2 Press **▲** or **▼** to choose `Set`.
- 3 Press **OK**.
- 4 Press **▲** or **▼** to choose the prestored ring pattern you want to use.
Press **OK**.
(You will hear each pattern as you scroll through the four patterns. Make sure you choose the pattern that the telephone company gave you.)
- 5 Press **Stop/Exit**.
Distinctive Ring is now set to On.

Turning off Distinctive Ring

- 1 Press **Menu, 2, 0, 2.**

```
Miscellaneous
2.Distinctive
```

- 2 Press **▲** or **▼** to choose `Off`.
Press **OK**.
- 3 Press **Stop/Exit**.

Note

If you do not want to receive faxes on your Distinctive Ring number, you can turn off Distinctive Ring. The machine will stay in `Manual` receive mode so you will need to set the Receive Mode again. (See *Choose the correct Receive Mode* on page 27.)

Connecting an external TAD (telephone answering device)

You can connect an external Telephone Answering Device (TAD) to the same line as your machine. When the TAD answers a call, your machine will “listen” for the CNG (fax calling) tones sent by a sending fax machine. If it hears them it will take over the call and receive the fax. If it does not hear them, it will let your TAD take a voice message and the display will show `Telephone`.

The external TAD must answer within four rings (we recommend you set it to two rings). This is because your machine cannot hear the CNG tones until the external TAD has picked up the call. The sending machine will send CNG tones for only eight to ten seconds longer. We do not recommend using the toll saver feature on your external TAD if it needs more than four rings to activate it.

Unless you are using Distinctive Ring, the TAD must be connected to the EXT. jack of the machine.

Before you connect an external TAD (telephone answering device), remove the protective cap (2) from the EXT. jack on the machine.

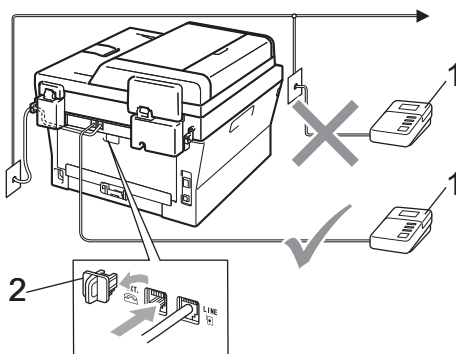

- 1 TAD
- 2 Protective Cap

Note

If you have problems receiving faxes, reduce the ring delay setting on your external TAD.

Connections

The external TAD must be plugged into the back of the machine, into the jack labeled EXT. Your machine cannot work properly if you plug the TAD into a wall jack (unless you are using Distinctive Ring).

- 1 Plug the telephone line cord from the telephone wall jack into the back of the machine, in the jack labeled LINE.
- 2 Plug the telephone line cord from your external TAD into the back of the machine, in the jack labeled EXT. (Make sure this cord is connected to the TAD at the TAD's telephone line jack, and not its handset jack.)
- 3 Set your external TAD to four rings or less. (The machine's Ring Delay setting does not apply.)
- 4 Record the outgoing message on your external TAD.
- 5 Set the TAD to answer calls.
- 6 Set the Receive Mode to `External TAD`. (See *Choose the correct Receive Mode* on page 27.)

Recording an outgoing message (OGM)

- 1 Record 5 seconds of silence at the beginning of your message. This allows your machine time to listen for fax tones.
- 2 Limit your speaking to 20 seconds.
- 3 End your 20-second message by giving your Fax Receive Code for people sending manual faxes. For example: "After the beep, leave a message or press *51 and **Start** to send a fax."



Note

We recommend beginning your OGM with an initial 5 second silence because the machine cannot hear fax tones over a loud voice. You may try leaving out this pause, but if your machine has trouble receiving, then you should re-record the OGM to include it.

Multi-line connections (PBX)

We suggest you ask the company who installed your PBX to connect your machine. If you have a multi line system we suggest you ask the installer to connect the unit to the last line on the system. This prevents the machine being activated each time the system receives telephone calls. If all incoming calls will be answered by a switchboard operator we recommend that you set the Receive Mode to *Manual*.

We cannot guarantee that your machine will operate properly under all circumstances when connected to a PBX. Any difficulties with sending or receiving faxes should be reported first to the company who handles your PBX.

External and extension telephones

Connecting an external or extension telephone

You can connect a separate telephone directly to your machine as shown in the diagram below.

Connect the telephone line cord to the jack labeled EXT.

Before you connect an external telephone, remove the protective cap (3) from the EXT. jack on the machine.

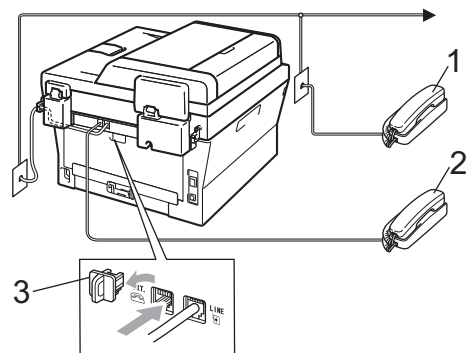

- 1 Extension telephone
- 2 External telephone
- 3 Protective Cap

When you are using an external telephone, the LCD shows *Telephone*.

Using external and extension telephones

Using extension telephones

If you answer a fax call at an extension telephone, you can make your machine receive the fax by pressing the Fax Receive Code *51.

If the machine answers a voice call and pseudo/double-rings for you to take over, you can take the call at an extension telephone by pressing the Telephone Answer Code #51. (See *F/T Ring Time (Fax/Tel mode only)* on page 30.)

Using an external telephone (Connected to the EXT. jack of the machine)

If you answer a fax call at the external telephone connected to the EXT jack of the machine, you can make the machine receive the fax by pressing **Start** and choosing *Receive*.

If the machine answers a voice call and pseudo/double-rings for you to take over, you can take the call at the external telephone by pressing **Hook**.

If you answer a call and no one is on the line:

You should assume that you're receiving a manual fax.

Press *51 and wait for the chirp or until the LCD shows *Receiving*, and then hang up.



Note

You can also use the Easy Receive feature to make your machine automatically take the call. (See *Easy Receive* on page 31.)

Using a non-Brother cordless external handset

If your non-Brother cordless telephone is connected to the EXT. jack of the machine (see *Connecting an external or extension telephone* on page 36) and you typically carry the cordless handset elsewhere, it is easier to answer calls during the Ring Delay.

If you let the machine answer first, you will have to go to the machine so you can press **Hook** to transfer the call to the cordless handset.

Using Remote Codes

Fax Receive Code

If you answer a fax call on an extension telephone, you can tell your machine to receive it by pressing the Fax Receive Code *51. Wait for the chirping sounds then replace the handset. (See *Easy Receive* on page 31.)

If you answer a fax call at the external telephone, you can make the machine receive the fax by pressing **Start**.

Telephone Answer Code

If you receive a voice call and the machine is in F/T mode, it will start to sound the F/T (double-ring) after the initial ring delay. If you pick up the call on an extension telephone you can turn the F/T ring off by pressing #51 (make sure you press this *between* the rings).

If the machine answers a voice call and pseudo/double-rings for you to take over, you can take the call at the external telephone by pressing **Hook**.

Changing the Remote Codes

The preset Fax Receive Code is *51. The preset Telephone Answer Code is #51. If you are always disconnected when accessing your External TAD, try changing the three-digit remote codes, for example ### and 999.

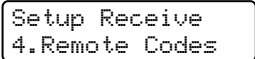
- 1 Make sure you are in Fax mode .
- 2 Press **Menu, 2, 1, 4**.

- 3 Press **▲** or **▼** to choose On (or Off). Press **OK**.
- 4 If you chose On in step 3, enter the new Fax Receive Code. Press **OK**.
- 5 Enter the new Telephone Answer Code. Press **OK**.
- 6 Press **Stop/Exit**.

7

Dialing and storing numbers

How to dial

You can dial in any of the following ways.

Manual dialing

Use the dial pad to enter all the digits of the telephone or fax number.



One touch dialing

Press the One Touch key that stores the number you want to call. (See *Storing One Touch Dial numbers* on page 42.)

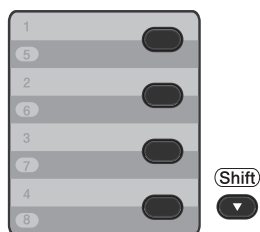

To dial One Touch numbers 5 to 8, hold down **Shift** as you press the One Touch key.

Speed Dialing

Press  (**Address Book**) and enter the three digit Speed Dial number. (See *Storing Speed Dial numbers* on page 44.)



Three-digit number



Note

If the LCD shows *Register Now?* when you enter a One Touch or a Speed Dial number, it means that a number is not stored there.

Search

You can search alphabetically for names you have stored in the One Touch and Speed Dial memories. (See *Storing One Touch Dial numbers* on page 42 and *Storing Speed Dial numbers* on page 44.)

- 1 Press  (**Address Book**) twice.
- 2 Press the dial pad key for the first few letters of the name. (Use the chart on *Entering text* on page 122 to help you enter letters.)
Press **OK**.
- 3 Press **▲** or **▼** to scroll until you find the name you are looking for.
Press **OK**.
- 4 Press **Start**.



Note

- If you do not enter a letter and press **OK** in step 2, all registered names will appear. Press **▲** or **▼** to scroll until you find the name you are looking for.
- If the LCD shows `No Contact Found` when you enter the first few letters of the name, it means that a name for the letter is not stored.

Fax redial

If you are sending a fax manually and the line is busy, press **Redial/Pause** and try it again. You can call the last number dialed by pressing **Redial/Pause**.

Redial/Pause only works if you dialed from the control panel.

If you are sending a fax automatically and the line is busy, the machine will automatically redial one time after five minutes.

Storing numbers

You can set up your machine to do the following types of easy dialing: One Touch, Speed Dial and Groups for Broadcasting faxes. You can also specify the default resolution for each One Touch and Speed Dial number. When you dial a quick dial number, the LCD shows the name, if you stored it, or the number. A scan profile can also be stored along with the fax number.

If you lose electrical power, the quick dial numbers stored in the memory will not be lost.

A scan profile is the resolution and other scan settings that you choose when you store a number. For example, you will be asked to select Standard, Fine, or Photo if you have selected the I-FAX option. Or, you will be asked to select B&W TIFF, B&W PDF, Gray JPG, Gray PDF, Gray XPS, Color JPG, Color PDF or Color XPS if you selected the E-Mail option. (I-FAX and E-mail options are available as a download for MFC-7460DN and MFC-7860DW only.)

One Touch and Speed Dial Options

The following chart shows the options for storing One Touch or Speed Dial numbers after you download the IFAX and E-mail options for MFC-7460DN and MFC-7860DW.

Step 1 Enter One Touch or Speed Dial Location	Step 2 Select Registration Type	Step 3 Enter Number or E-mail Address	Step 4 Enter Name	Step 5 Select Resolution	Step 6 Select File Type
One Touch or Speed Dial	Fax/Tel	Fax Number or Tel Number	(Name) Press OK .	Std, Fine, S.Fine, Photo	—
	IFAX	E-mail Address		Std, Fine, Photo	—
	Email Color PDF			100dpi, 200dpi, 300dpi, 600dpi	PDF, SPDF
	Email Color JPG			100dpi, 200dpi, 300dpi, 600dpi	—
	Email Color XPS			100dpi, 200dpi, 300dpi, 600dpi	—
	Email Gray PDF			100dpi, 200dpi, 300dpi	PDF, SPDF
	Email Gray JPG			100dpi, 200dpi, 300dpi	—
	Email Gray XPS			100dpi, 200dpi, 300dpi	—
	Email B&W PDF			200dpi, 200x100dpi	PDF, SPDF
	Email B&W TIFF			200dpi, 200x100dpi	—

Storing a pause

Press **Redial/Pause** to insert a 3.5-second pause between numbers. You can press **Redial/Pause** as many times as needed to increase the length of the pause.

Storing One Touch Dial numbers

Your machine has 4 One Touch keys where you can store 8 fax or telephone numbers for automatic dialing. To access numbers 5 to 8, hold down **Shift** as you press the One Touch key.

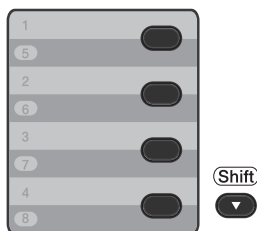

- 1 Press the One Touch key where you want to store the number. If a number is not stored there, the LCD shows *Register Now?* Press **1** to choose *Yes*.
- 2 Enter the telephone or fax number (up to 20 characters). Press **OK**.
- 3 Choose one of the following:
 - Enter the name using the dial pad (up to 15 characters). Use the chart on *Entering text* on page 122 to help you enter letters. Press **OK**.
 - Press **OK** to store the number without a name.

- 4 If you want to save a fax resolution along with the number, choose one of the following:
 - To store the fax resolution, press **▲** or **▼** to select *Std*, *Fine*, *S.Fine* or *Photo*. Press **OK**.
 - Press **OK** if you do not want to change the default resolution.

If you downloaded I-FAX and E-mail options (For MFC-7460DN and MFC-7860DW)

- 1 Press the One Touch key where you want to store the number. If a number is not stored there, the LCD shows *Register Now?* Press **1** to choose *Yes*.
- 2 Press **▲** or **▼** to select one of the following:
 - Fax/Tel
 - IFAX
 - Email Color PDF
 - Email Color JPG
 - Email Color XPS
 - Email Gray PDF
 - Email Gray JPG
 - Email Gray XPS
 - Email B&W PDF
 - Email B&W TIFF
 Press **OK**.
- 3 Enter the telephone, fax number (up to 20 characters) or E-mail address (up to 60 characters each). Use the chart on *Entering text* on page 122 to help you enter letters. Press **OK**.



Note

- If you selected an E-Mail Registration Type in step 2 and save the E-mail address, you can only use the E-mail address when you are in Scan mode.

- If you selected the IFAX Registration Type in step ② and save the E-mail address, you can only use the E-mail address when you are in Fax mode.

- 4 Do one of the following:
- Enter the name using the dial pad (up to 15 characters).
Press **OK**.
 - Press **OK** to store the number without a name.
- 5 Do one of the following:
- If you want to save a fax/scan resolution along with the number, go to the appropriate step as shown in the following table:
 - If you do not want to change the default resolution, press **OK**, then go to step ⑫.

Option selected in step ②	Go to step
Fax/Tel	⑥
IFAX	⑦
Email Color PDF	⑧
Email Color JPG	
Email Color XPS	
Email Gray PDF	⑨
Email Gray JPG	
Email Gray XPS	
Email B&W PDF	⑩
Email B&W TIFF	



Note

- When you do a broadcast and you have saved a scan profile along with the number or E-mail address, the scan profile of the One Touch, Speed Dial or Group number you choose first will be applied to the broadcast.
- You can also store the number by pressing **Menu, 2, 3, 1**.

- For details about the file format, see the *Software User's Guide*

- 6 Press **▲** or **▼** to select **Std, Fine, S.Fine** or **Photo**.
Press **OK** and go to step ⑫.
- 7 Press **▲** or **▼** to select **Std, Fine** or **Photo**.
Press **OK** and go to step ⑫.
- 8 Press **▲** or **▼** to select **100dpi, 200dpi, 300dpi** or **600dpi**.
Press **OK**.
- If you chose **Email Color PDF**, go to step ⑪.
 - If you chose **Email Color JPG** or **Email Color XPS**, go to step ⑫.
- 9 Press **▲** or **▼** to select **100dpi, 200dpi** or **300dpi**.
Press **OK**.
- If you chose **Email Gray PDF**, go to step ⑪.
 - If you chose **Email Gray JPG** or **Email Gray XPS**, go to step ⑫.
- 10 Press **▲** or **▼** to select **200x100dpi** or **200dpi**.
Press **OK**.
- If you chose **Email B&W PDF**, go to step ⑪.
 - If you chose **Email B&W TIFF**, go to step ⑫.
- 11 Select the PDF type from **PDF** or **SPDF** (Secure PDF) that will be used to send to your PC.
Press **OK** and then go to step ⑫.
- 12 Press **Stop/Exit**.

Storing Speed Dial numbers

You can store your frequently used numbers as Speed Dial numbers, so that when you dial you will only have to press a few keys

( **(Address Book)**, the three-digit number and **Start**). The machine can store 200 Speed Dial numbers (001 - 200).

- 1 Press  **(Address Book)** and enter a three-digit Speed Dial location number (001-200). If a number is not stored there, the LCD shows `Register Now?` Press **1** to choose `Yes`.
- 2 Enter the telephone or fax number (up to 20 characters). Use the chart on *Entering text* on page 122 to help you enter letters.
Press **OK**.
- 3 Do one of the following:
 - Enter the name using the dial pad (up to 15 characters).
Press **OK**.
 - Press **OK** to store the number without a name.
- 4 If you want to save a fax resolution along with the number, do one of the following:
 - To store the fax resolution, press **▲** or **▼** to select `Std`, `Fine`, `S. Fine` or `Photo`.
Press **OK**.
 - Press **OK** if you do not want to change the default resolution.

If you downloaded IFAX and E-mail options (For MFC-7460DN and MFC-7860DW)

- 1 Press  **(Address Book)** and enter a three-digit Speed Dial location number (001-200).
If a number is not stored there, the LCD shows `Register Now?`
Press **1** to choose `Yes`.
- 2 Press **▲** or **▼** to select one of the following:
Fax/Tel
IFAX
Email Color PDF
Email Color JPG
Email Color XPS
Email Gray PDF
Email Gray JPG
Email Gray XPS
Email B&W PDF
Email B&W TIFF
Press **OK**.
- 3 Enter the telephone, fax number (up to 20 characters each) or E-mail address (up to 60 characters each). Use the chart on *Entering text* on page 122 to help you enter letters.
Press **OK**.



Note

- If you selected an E-Mail Registration Type in step 2 and save the E-mail address, you can only use the E-mail address when you are in Scan mode.
- If you selected the IFAX Registration Type in step 2 and save the E-mail address, you can only use the E-mail address when you are in Fax mode.

- 4 Do one of the following:
 - Enter the name using the dial pad (up to 15 characters).
Press **OK**.
 - Press **OK** to store the number without a name.

- 5 Do one of the following:
- If you want to save a fax/scan resolution along with the number, go to the appropriate step as shown in the following table:
 - If you do not want to change the default resolution, press **OK**, then go to step 12.

Option selected in step 2	Go to step
Fax/Tel	6
IFAX	7
Email Color PDF	8
Email Color JPG	
Email Color XPS	
Email Gray PDF	9
Email Gray JPG	
Email Gray XPS	
Email B&W PDF	10
Email B&W TIFF	



Note

- When you do a broadcast and you have saved a scan profile along with the number or E-mail address, the scan profile of the One Touch, Speed Dial or Group number you choose first will be applied to the broadcast.
- You can also store the number by pressing **Menu, 2, 3, 2**.
- For details about the file format, see the *Software User's Guide*

- 6 Press **▲** or **▼** to select **Std, Fine, S.Fine** or **Photo**. Press **OK** and go to step 12.
- 7 Press **▲** or **▼** to select **Std, Fine** or **Photo**. Press **OK** and go to step 12.

- 8 Press **▲** or **▼** to select **100dpi, 200dpi, 300dpi** or **600dpi**. Press **OK**.
- If you chose **Email Color PDF**, go to step 11.
 - If you chose **Email Color JPG** or **Email Color XPS**, go to step 12.
- 9 Press **▲** or **▼** to select **100dpi, 200dpi** or **300dpi**. Press **OK**.
- If you chose **Email Gray PDF**, go to step 11.
 - If you chose **Email Gray JPG** or **Email Gray XPS**, go to step 12.
- 10 Press **▲** or **▼** to select **200x100dpi** or **200dpi**. Press **OK**.
- If you chose **Email B&W PDF**, go to step 11.
 - If you chose **Email B&W TIFF**, go to step 12.
- 11 Select the PDF type from **PDF** or **SPDF** (Secure PDF) that will be used to send to your PC. Press **OK** and then go to step 12.
- 12 Press **Stop/Exit**.

Changing One Touch and Speed Dial numbers

If you try to change an existing One Touch or Speed Dial number, the LCD will show the name or number already stored there. If the existing One Touch or Speed Dial number you are trying to change has a schedule job or has been set to a fax forwarding number, the LCD will ask you if you want to change the name or number.

1 Do one of the following:

- To change a stored One Touch number, press **Menu, 2, 3, 1**.

```
Address Book
1.One Touch Dial
```

Press the One Touch key number you want to change.

- To change a stored Speed Dial number, press **Menu, 2, 3, 2**.

```
Address Book
2.Speed Dial
```

Enter the Speed Dial number you want to change, then press **OK**.

2 Do one of the following:

- To change the stored data, press **1**. Go to step 3.
- To exit without making a change, press **Stop/Exit**.

```
#005:MIKE
1.Change 2.Clear
```

3 Edit the number and name by the following the instruction. When you are finished editing, press **OK**.

- To edit the stored name or number, press **◀** or **▶** to position the cursor under the character you want to change and press **Clear**. Then enter the correct character.

4 If you want to save a fax resolution along with the number, do one of the following:

- To store the fax resolution, press **▲** or **▼** to select *Std*, *Fine*, *S.Fine* or *Photo*.
Press **OK**.
- Press **OK** if you do not want to change the default resolution.

5 Press **Stop/Exit**.

If you downloaded I-FAX and E-mail options (For MFC-7460DN and MFC-7860DW)

1 Do one of the following:

- To change a stored One Touch number, press **Menu, 2, 3, 1**.

```
One Touch Dial
Select One Touch
```

Choose the One Touch number you want to change.

- To change a stored Speed Dial number, press **Menu, 2, 3, 2**.

```
Speed Dial
Speed Dial? #
```

Choose the Speed Dial number you want to change, then press **OK**.

2 Do one of the following:

- To change the stored number, press **1**.
- To exit without making a change, press **Stop/Exit**.

```
#005:MIKE
1.Change 2.Clear
```

- 3 Press ▲ or ▼ to select one of the following:
 Fax/Tel
 IFAX
 Email Color PDF
 Email Color JPG
 Email Color XPS
 Email Gray PDF
 Email Gray JPG
 Email Gray XPS
 Email B&W PDF
 Email B&W TIFF
 Press **OK**.
- 4 Press ◀ or ▶ to position the cursor under the character you want to change, and then press **Clear** to delete it. Repeat for each character you want to delete. Enter a new number or character. Press **OK**.
- 5 Follow the directions beginning in step 4 in Storing One-Touch dial numbers and Storing Speed-Dial numbers. (See *Storing One Touch Dial numbers* on page 42 and *Storing Speed Dial numbers* on page 44.)
- 6 Press **Stop/Exit**.

Deleting One Touch and Speed Dial numbers

If you try to delete an existing One Touch or Speed Dial number, the LCD will show the name or number already stored there. If the existing One Touch or Speed Dial number you are trying to change has a schedule job or has been set to a fax forwarding number, the LCD will ask you if you want to change the name or number.

- 1 Do one of the following:
- To delete a stored One Touch number, press **Menu, 2, 3, 1**.

```
Address Book
1.One Touch Dial
```

Press the One Touch key number you want to delete.

- To delete a stored Speed Dial number, press **Menu, 2, 3, 2**.

```
Address Book
2.Speed Dial
```

Enter the Speed Dial number you want to delete then press **OK**.

- 2 To delete the stored data, press **2**.

```
#005:MIKE
1.Change 2.Clear
```

- 3 Do one of the following:
- To delete the stored data, press **1**.
 - To exit without deleting the stored data, press **2**.

```
Erase This Data?
1.Yes 2.No
```

- 4 Press **Stop/Exit**.

8

Making copies

How to copy

The following steps show the basic copy operation. For details about each option, see the *Advanced User's Guide* on the CD-ROM.

- 1 When you want to make a copy, press

 (**COPY**) to illuminate it in blue.

- Make sure you are in Copy mode.

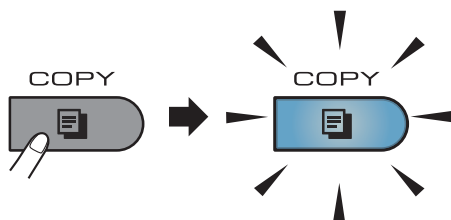

- The LCD shows:

```
Stack   Copies:01  
100%   □□■□□ Auto
```



Note

The default setting is Fax mode. You can change the amount of time that the machine stays in Copy mode after the last copy operation. (See *Mode Timer* in *Chapter 1* of the *Advanced User's Guide*)

- 2 Do one of the following to load your document:
 - Place the document *face up* in the ADF. (See *Using the automatic document feeder (ADF)* on page 22.)
 - Load your document *face down* on the scanner glass. (See *Using the scanner glass* on page 23.)
- 3 Press **Start**.

Stop copying

To stop copying, press **Stop/Exit**.

Copy settings

Press the temporary **Copy** keys. You can use **Options**, **Enlarge/Reduce** or **Duplex**¹.

For details about changing the copy settings, see *Copy settings* in *Chapter 7* of the *Advanced User's Guide*.

You can change the following copy settings:

- Enlarge/Reduce
- Quality
- Stack/Sort
- Brightness
- Contrast
- Page Layout
- Duplex Copying (1-sided to 2-sided)¹

¹ For MFC-7460DN and MFC-7860DW

Printing a document

The machine can receive data from your computer and print it. To print from a computer, install the printer driver. (See *Printing for Windows*[®] or *Printing and Faxing* for Macintosh in *Software User's Guide* for details about the print settings.)

- 1 Install the Brother printer driver on the Installation CD-ROM. (See the *Quick Setup Guide*.)
- 2 From your application, choose the Print command.
- 3 Choose the name of your machine in the **Print** dialog box and click **Properties**.
- 4 Choose the settings you want in the **Properties** dialog box.
 - **Paper Size**
 - **Orientation**
 - **Copies**
 - **Media Type**
 - **Resolution**
 - **Print Settings**
 - **Multiple Page**
 - **Duplex / Booklet**
 - **Paper Source**
- 5 Click **OK** to begin printing.

Scanning a document

There are several ways to scan documents. You can use the  (**SCAN**) key on the machine or the scanner drivers on your computer.

- 1 To use the machine as a scanner, install a scanner driver. If the machine is on a Network, configure it with a TCP/IP address.
 - Install the scanner drivers on the Installation CD-ROM. (See the *Quick Setup Guide* and *Scanning* in the *Software User's Guide*.)
 - Configure the machine with a TCP/IP address if network scanning does not work. (See *Configuring Network Scanning* in the *Software User's Guide*.)
- 2 Load your document. (See *How to load documents* on page 22.)
 - Use the ADF to scan multiple pages of documents. It feeds each sheet automatically.
 - Use the scanner glass to scan a page of a book or one sheet at a time.
- 3 Do one of the following:
 - To scan using the  (**SCAN**) key, go to *Scanning using the scan key* on page 50.
 - To scan using a scanner driver at your computer, go to *Scanning using a scanner driver* on page 51.

Scanning using the scan key

For more information, see *Using the Scan key* in the *Software User's Guide*.

- 1 Press the  (**SCAN**) key.
- 2 Choose the scan mode you want. Scan to:
 - File
 - E-mail
 - OCR ¹
 - Image
 - FTP ²

¹ (Macintosh users)
This function is available after you download and install Presto! PageManager from http://nj.newsoft.com.tw/download/brother/PM9SEInstaller_BR_multilang.dmg

² For MFC-7460DN and MFC-7860DW
- 3 Choose the computer you want to send the data to.
- 4 Press **Start** to begin scanning.

Scanning using a scanner driver

For more information, see *Scanning a document using the TWAIN driver* or *Scanning a document using the WIA driver* in the *Software User's Guide*.

- 1 Start a scanning application and click the **Scan** button.
- 2 Adjust the settings such as Resolution, Brightness and Scan Type in the Scanner Setup dialog box.
- 3 Click **Start** or **Scan** to begin scanning.

A

Routine maintenance

Replacing the consumable items

The machine will indicate when it is time to replace the consumable items. (See *Replacing the toner cartridge* on page 53 and *Replacing the drum unit* on page 59.)

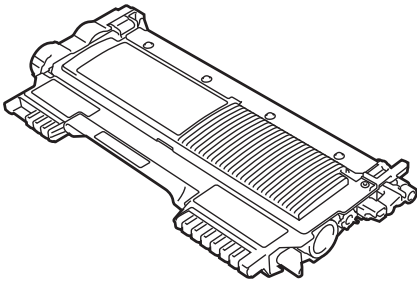
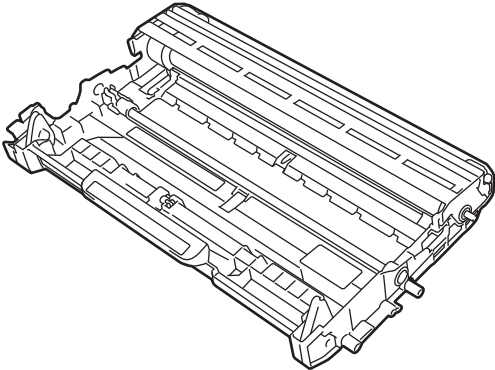
Toner cartridge	Drum unit
See <i>Replacing the toner cartridge</i> on page 53. Order No. TN-420, TN-450	See <i>Replacing the drum unit</i> on page 59. Order No. DR-420
	

Note

- Go to <http://www.brother.com/original/index.html> for instructions on how to return your used consumable items to the Brother collection program. If you choose not to return your used consumable, please discard the used consumable according to local regulations, keeping it separate from domestic waste. If you have questions, call your local waste disposal office.
- We recommend placing used consumable items on a piece of paper to prevent accidentally spilling or scattering the material inside.
- If you use paper that is not a direct equivalent for the recommended paper, the life of consumable items and machine parts may be reduced.
- The projected life of the toner cartridges is based on ISO/IEC 19752. Frequency of replacement will vary depending on the complexity of printed pages, percentage of coverage and type of media used.

Replacing the toner cartridge

Order Number: For the order numbers of toner cartridges, see *Replacing the consumable items* on page 52.

The Standard toner cartridge can print approximately 1,200 pages¹. The High Yield toner cartridge can print approximately 2,600 pages¹. Actual page count will vary depending on your average type of document. When a toner cartridge is running low, the LCD shows `Toner Low`.

The toner cartridge that comes supplied with the machine is a Starter toner cartridge that will need to be replaced after approximately 700 pages¹.

¹ Approx. cartridge yield is declared in accordance with ISO/IEC 19752.



Note

- It is a good idea to keep a new toner cartridge ready for use when you see the `Toner Low` warning.
- To ensure high quality printing, we recommend that you use only Genuine Brother Brand toner cartridges. When you want to buy toner cartridges, please call Brother Customer Service.
- We recommend that you clean the machine when you replace the toner cartridge. See *Cleaning the machine* in Appendix A of the *Advanced User's Guide*.
- If you change the print density setting for lighter or darker printing, the amount of toner used will change.
- Wait to unpack the toner cartridge until immediately before you put it into the machine.

Toner Low

`Toner Low`

If the LCD shows `Toner Low`, buy a new toner cartridge and have it ready before you get a `Replace Toner` message.

Replace Toner

When the following message appears on the LCD, you need to replace the toner cartridge:

`Replace Toner`

The machine will stop printing until you replace the toner cartridge. A new and unused genuine Brother toner cartridge will reset the `Replace Toner` mode.



Note

To force the machine to continue printing after the LCD shows `Replace Toner`, set the machine to Continue mode (**Menu, 1, 8**, and choose `Continue`). The machine will continue printing until the LCD shows `Toner Ended`. (For details about the Toner settings, see *Toner Settings* in Chapter 1 of the *Advanced User's Guide*.)

Toner Ended

When the following message appears on the LCD, you need to replace the toner cartridge:

`Toner Ended`

The machine stops printing until you replace the toner cartridge with a new one. (See *Replacing the toner cartridge* on page 53.)

Replacing the toner cartridge

- 1 Make sure that the machine is turned on.

- 2 Open the front cover and leave the machine turned on for 10 minutes to cool down.

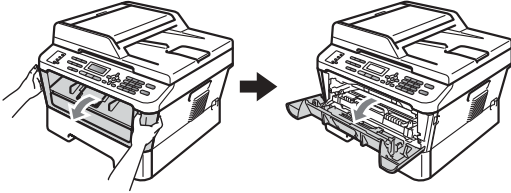

! WARNING

HOT SURFACE

After you have just used the machine, some internal parts of the machine will be extremely hot. Wait for the machine to cool down before you touch the internal parts of the machine.

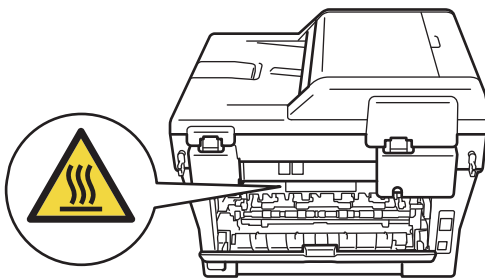
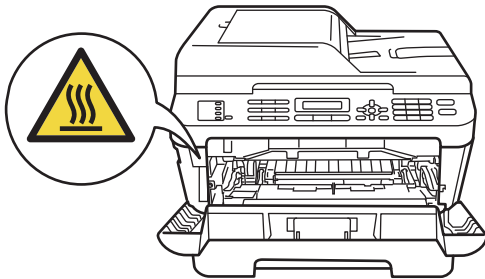

- 3 Take out the drum unit and toner cartridge assembly.

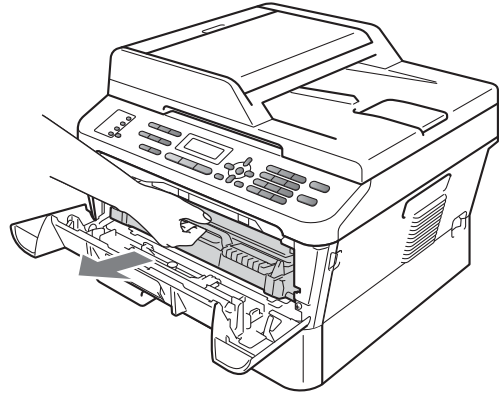

- 4 Push down the green lock lever and take the toner cartridge out of the drum unit.

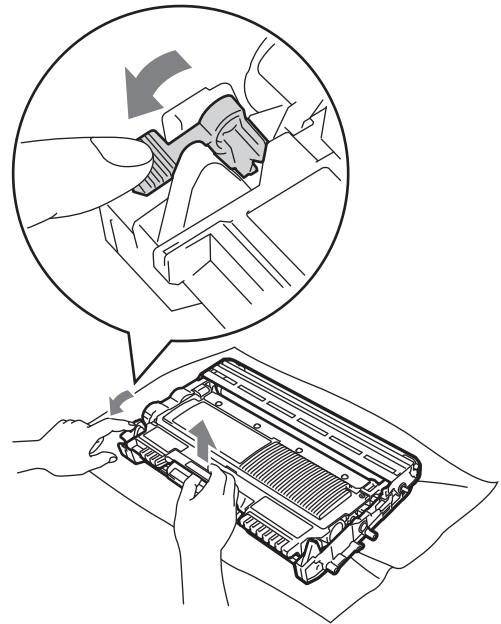

⚠ WARNING

DO NOT put a toner cartridge into a fire. It could explode, resulting in injuries.

DO NOT use cleaning materials that contain ammonia, alcohol, any type of spray or any type of flammable substance to clean the inside or outside of the machine. Doing this may cause a fire or electrical shock.

See *To use the product safely* in the *Safety and Legal booklet* for how to clean the machine.



Be careful not to inhale toner.

⚠ IMPORTANT

- We recommend that you place the drum unit and/or the toner cartridge on a clean, flat, level, stable surface with a sheet of disposable paper or cloth underneath it in case you accidentally spill or scatter toner.
- Handle the toner cartridge carefully. If toner scatters on your hands or clothes, immediately wipe or wash it off with cold water.

- To avoid print quality problems, DO NOT touch the shaded parts shown in the illustration.

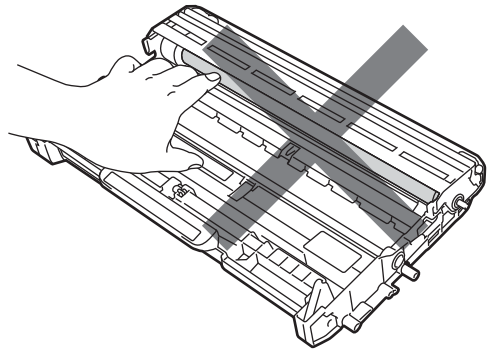
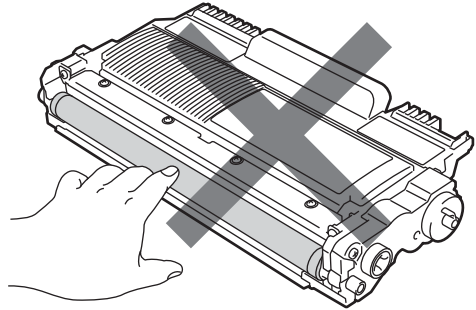
**Note**

- Be sure to seal up the toner cartridge tightly in a suitable bag so that toner powder does not spill out of the cartridge.
- Go to <http://www.brother.com/original/index.html> for instructions on how to return your used consumable items to the Brother collection program. If you choose not to return your used consumable, please discard the used consumable according to local regulations, keeping it separate from domestic waste. If you have questions, call your local waste disposal office.

- 5 Unpack the new toner cartridge. Hold the cartridge level with both hands and gently shake it from side to side several times to spread the toner evenly inside the cartridge.

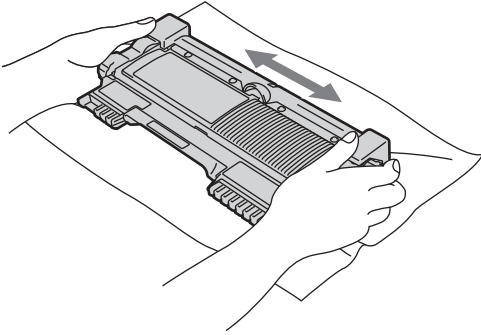

! IMPORTANT

- Wait to unpack the new toner cartridge until immediately before you put it in the machine. If a toner cartridge is left unpacked for a long time, the toner life will be shortened.
- Brother strongly recommends that you DO NOT refill the toner cartridge provided with your machine. We also strongly recommend that you continue to use only Genuine Brother Brand replacement toner cartridges. Use or attempted use of potentially incompatible toner and/or cartridges in the Brother machine may cause damage to the machine and/or may result in unsatisfactory print quality. Our warranty coverage does not apply to any problem that is caused by the use of unauthorized third-party toner and/or cartridges. To protect your investment and obtain premium performance from the Brother machine, we strongly recommend the use of Genuine Brother Supplies.

- 6 Pull off the protective cover.

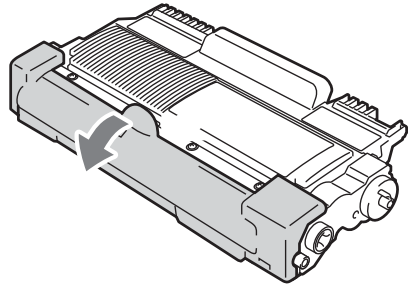

! IMPORTANT

Put the toner cartridge in the drum unit immediately after you have removed the protective cover. To prevent any degradation to the print quality, DO NOT touch the shaded parts shown in the illustrations.

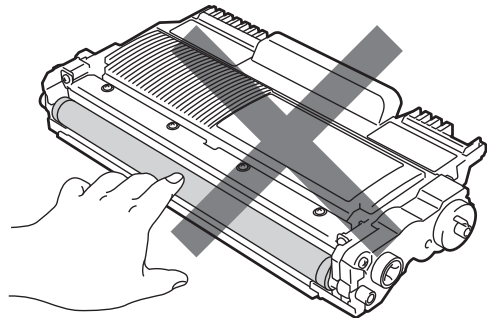

- 7 Put the new toner cartridge firmly into the drum unit until you hear it lock into place. If you put it in properly, the green lock lever will lift automatically.

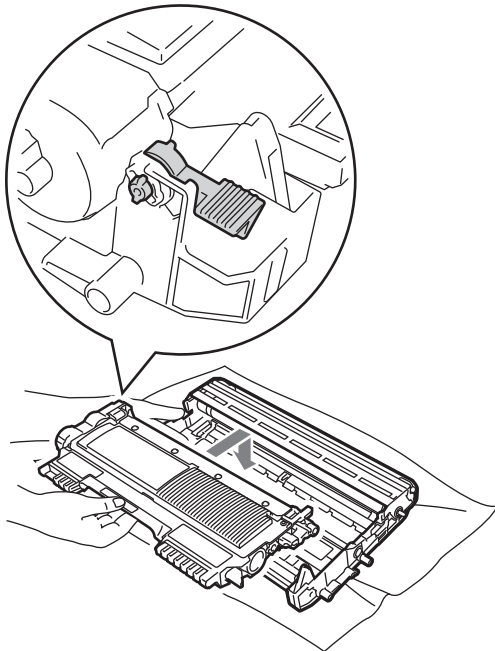
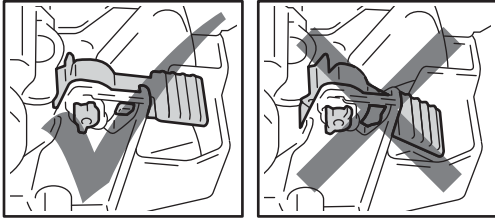

Note

Make sure that you put in the toner cartridge properly or it may separate from the drum unit.

- 8 Clean the corona wire inside the drum unit by gently sliding the green tab from left to right and right to left several times.

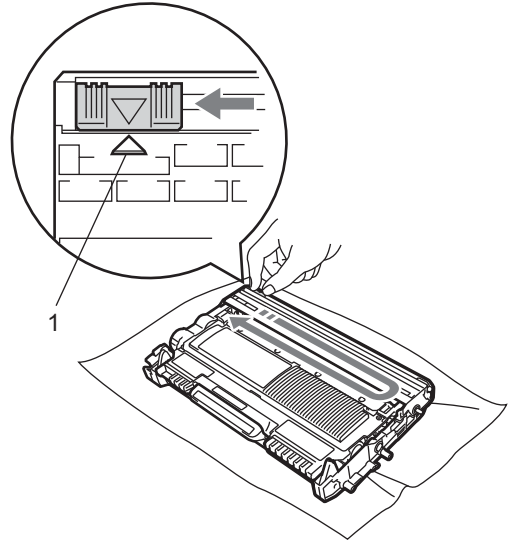

Note

Be sure to return the tab to the home position (▲) (1). If you do not, printed pages may have a vertical stripe.

- 9 Put the drum unit and toner cartridge assembly back into the machine. Close the front cover.

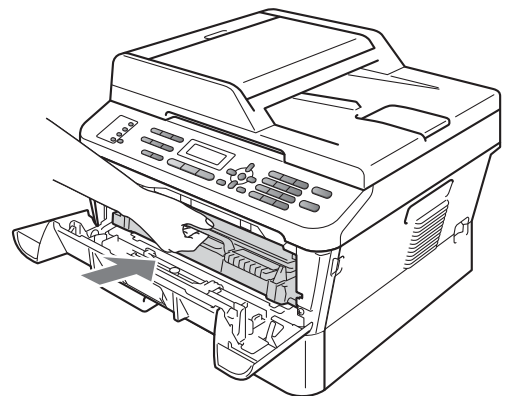

 **Note**

After replacing the toner cartridge, DO NOT turn off the machine's power switch or open the front cover until the LCD clears the Please Wait message and returns to Ready mode.

Cleaning the corona wire

If you have print quality problems, clean the corona wire as follows:

- 1 Open the front cover and leave the machine turned on for 10 minutes to cool down.

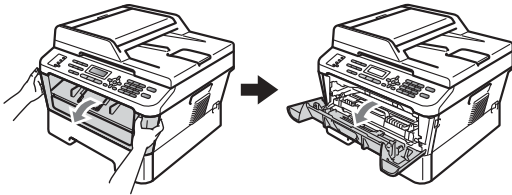

WARNING

HOT SURFACE

After you have just used the machine, some internal parts of the machine will be extremely hot. Wait for the machine to cool down before you touch the internal parts of the machine.

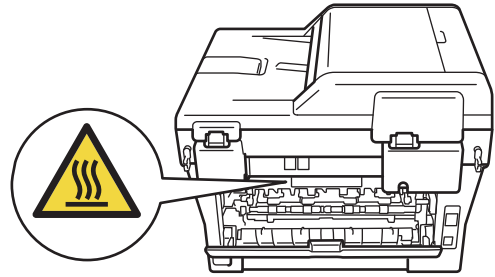
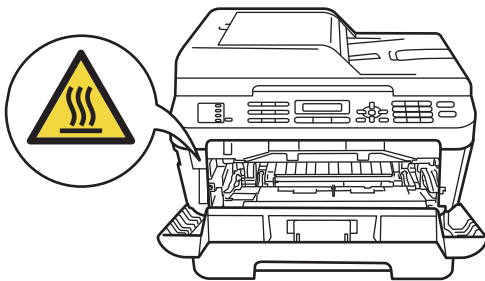

- 2 Slowly take out the drum unit and toner cartridge assembly.

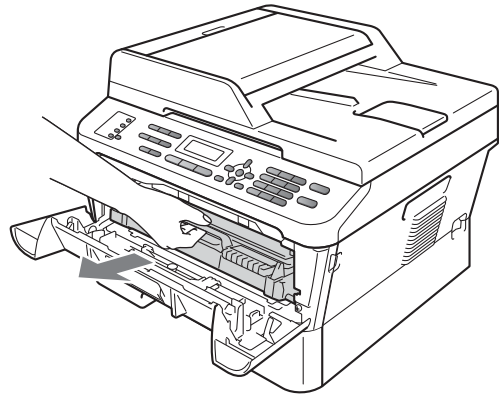

CAUTION

We recommend that you place the drum unit and toner cartridge assembly on a clean, flat surface with a sheet of disposable paper or cloth underneath it in case you accidentally spill or scatter toner.

Handle the toner cartridge carefully. If toner scatters on your hands or clothes, immediately wipe or wash it off with cold water.

To prevent damage to the machine caused by static electricity, DO NOT touch the electrodes shown in the illustration.

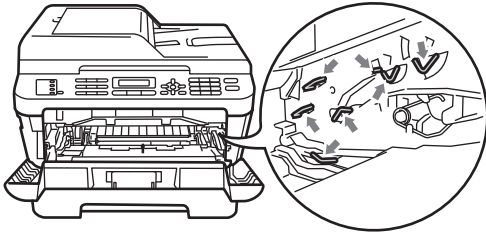

- 3 Clean the corona wire inside the drum unit by gently sliding the green tab from right to left and left to right several times.

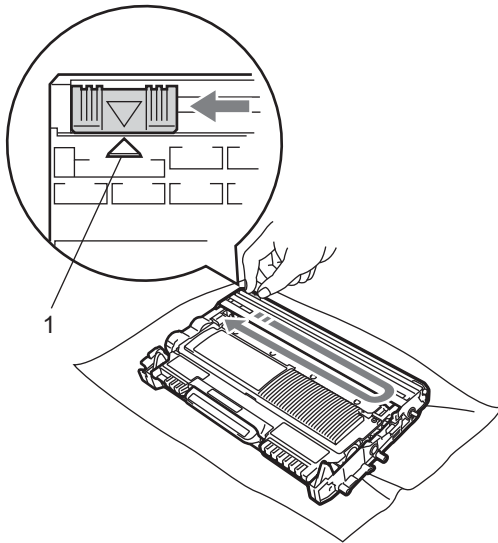

Note

Be sure to return the tab to the home position (▲) (1). If you do not, printed pages may have a vertical stripe.

- 4 Put the drum unit and toner cartridge assembly back into the machine. Close the front cover.

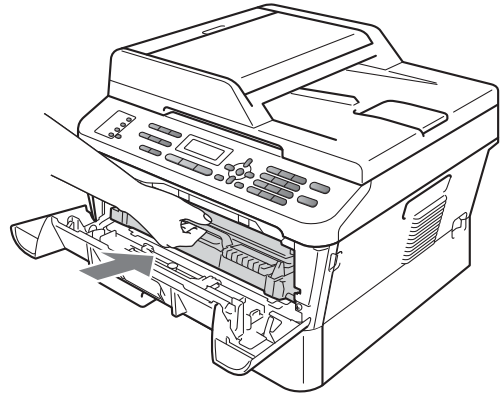

Replacing the drum unit

Order No. DR-420

A new drum unit can print approximately 12,000 Letter or A4 size single-sided pages.

Note

- There are many factors that determine the actual drum life, such as the temperature, humidity, type of paper, type of toner used and so on. Under ideal conditions, the average drum life is estimated at approximately 12,000 pages. The actual number of pages that your drum will print may be significantly less than this estimate. Because we have no control over the many factors that determine the actual drum life, we cannot guarantee a minimum number of pages that will be printed by your drum.
- For best performance, use only genuine Brother toner. The machine should be used only in a clean, dust-free environment with adequate ventilation.

- Printing with a non Brother drum unit may reduce not only the print quality but also the quality and life of the machine itself. Warranty coverage does not apply to problems caused by the use of a non Brother drum unit.

Drum Error

Drum Error

The corona wire has become dirty. Clean the corona wire in the drum unit. (See *Cleaning the corona wire* on page 58.)

If you cleaned the corona wire and **Drum Error** was not cleared, replace the drum unit with a new one.

Replace Drum

Replace Drum

Please replace the drum unit with a new one. We recommend a genuine Brother drum unit be installed at this time.

After replacement, reset the drum counter by following the instructions included with the new drum unit.

Drum Stop

Drum Stop

We cannot guarantee the print quality. Please replace the drum unit with a new one. We recommend a genuine Brother drum unit be installed at this time.

After replacement, reset the drum counter by following the instructions included with the new drum unit.

Replacing the drum unit

! IMPORTANT

- While removing the drum unit, handle it carefully because it may contain toner. If toner scatters on your hands or clothes, immediately wipe or wash it off with cold water.
- Every time you replace the drum unit, clean the inside of the machine. (See *Cleaning the machine* in *Appendix A* of the *Advanced User's Guide*.)

- 1 Make sure that the machine is turned on.
- 2 Open the front cover and leave the machine turned on for 10 minutes to cool down.

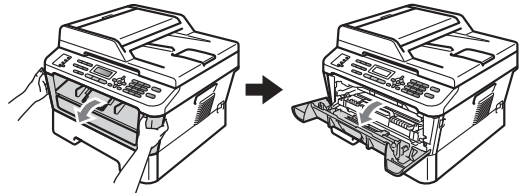

! WARNING

HOT SURFACE

After you have just used the machine, some internal parts of the machine will be extremely hot. Wait for the machine to cool down before you touch the internal parts of the machine.

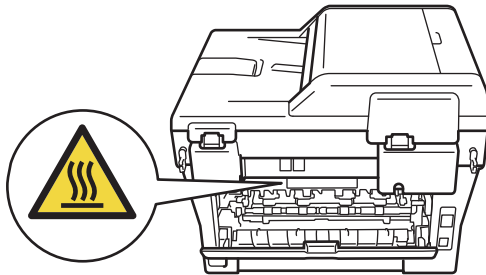
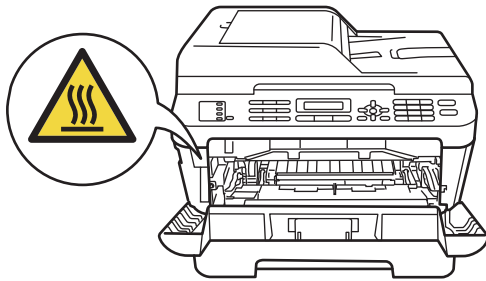

- 4 Push down the green lock lever and take the toner cartridge out of the drum unit.

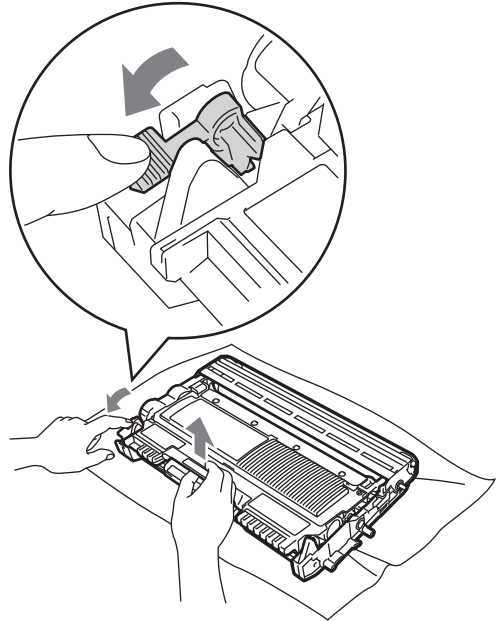

- 3 Take out the drum unit and toner cartridge assembly.

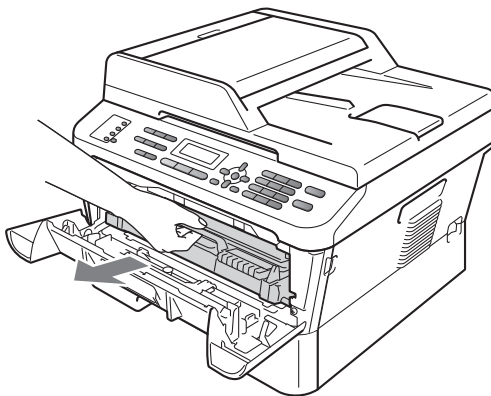

! WARNING

DO NOT put a toner cartridge into a fire. It could explode, resulting in injuries.

DO NOT use cleaning materials that contain ammonia, alcohol, any type of spray, or any type of flammable substance to clean the outside or inside of the machine. Doing this may cause a fire or electrical shock.

See *To use the product safely* in the *Safety and Legal* booklet for how to clean the machine.



Be careful not to inhale toner.

! IMPORTANT

- To prevent damage to the machine from static electricity, **DO NOT** touch the electrodes shown in the illustration.

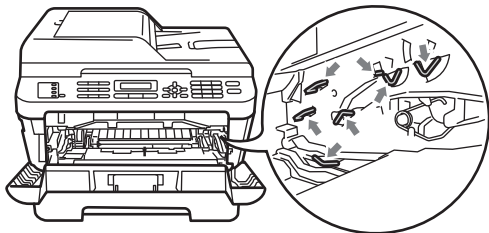

- Handle the toner cartridge carefully. If toner scatters on your hands or clothes, immediately wipe or wash it off with cold water.
- We recommend that you place the drum unit and/or the toner cartridge on a clean, flat surface with a sheet of disposable paper or cloth underneath it in case you accidentally spill or scatter toner.
- To avoid print quality problems, **DO NOT** touch the shaded parts shown in the illustrations.

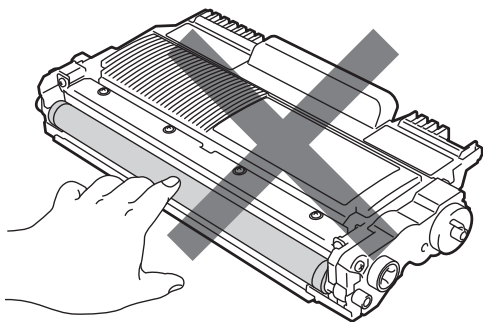

📄 Note

- Be sure to seal up the used drum unit tightly in a bag so that toner powder does not spill out of the unit.
- Go to <http://www.brother.com/original/index.html> for instructions on how to return your used consumable items to the Brother collection program. If you choose not to return your used consumable, please discard the used consumable according to local regulations, keeping it separate from domestic waste. If you have questions, call your local waste disposal office.

5 Unpack the new drum unit.

! IMPORTANT

- To avoid print quality problems, **DO NOT** touch the shaded parts shown in the illustrations.

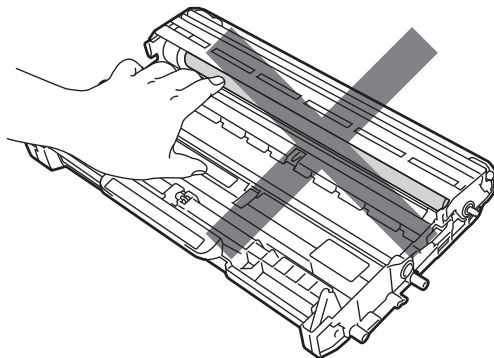

- Wait to unpack the new drum unit until immediately before you put it in the machine. Exposure to direct sunlight or room light may damage the drum unit.

- 6 Put the toner cartridge firmly into the new drum unit until you hear it lock into place. If you put the cartridge in properly, the green lock lever will lift automatically.

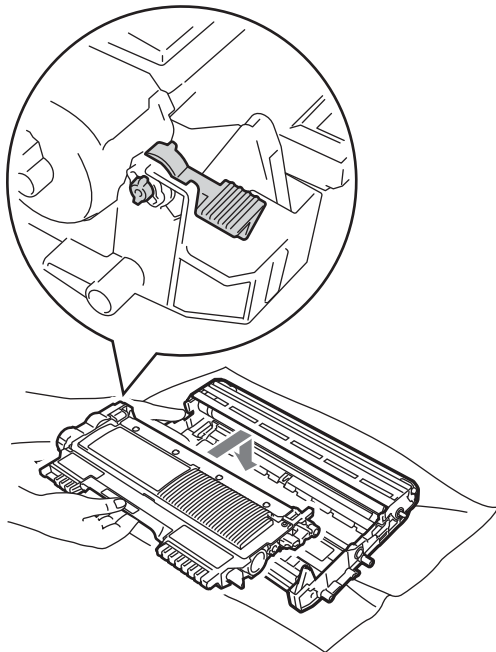
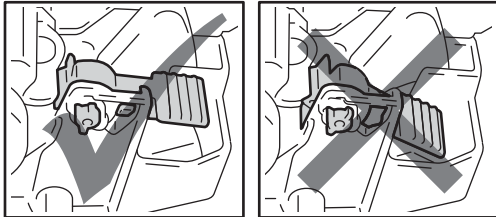

Note
Make sure that you put in the toner cartridge properly or it may separate from the drum unit.

- 7 Clean the corona wire of the drum unit by gently sliding the green tab from left to right and right to left several times.

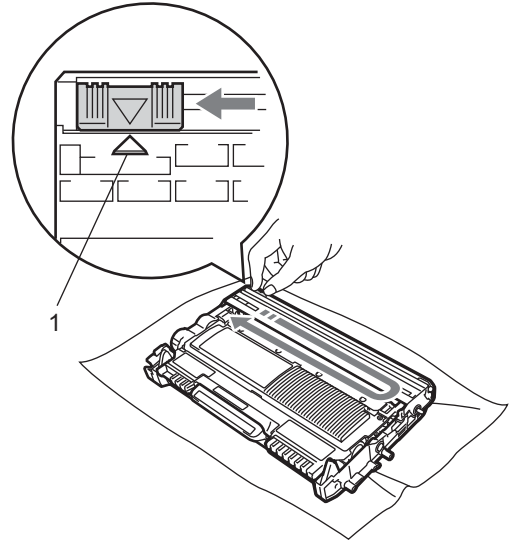

Note
Be sure to return the green tab to the home position (▲) (1). If you do not, printed pages may have a vertical stripe.

- 8 Put the new drum unit and toner cartridge assembly in the machine.

Resetting the drum counter

When you replace the drum unit with a new one, you need to reset the drum counter by completing the following steps:

- 1 Press **Clear**.
To confirm you are installing a new drum unit, press **1**.
- 2 When the LCD shows *Accepted*, close the front cover.

B

Troubleshooting

Error and maintenance messages

As with any sophisticated office product, errors may occur and consumable items may need to be replaced. If this happens, your machine identifies the error or required routine maintenance and shows the appropriate message. The most common error and maintenance messages are shown below.

You can correct most errors and perform routine maintenance by yourself. If you need more help, the Brother Solutions Center offers the latest FAQs and troubleshooting tips:

Visit us at <http://solutions.brother.com/>.

Error Message	Cause	Action
Access Denied	The function you want to use is restricted by Secure Function Lock.	Contact your administrator to check your Secure Function Lock Settings.
Cartridge Error	The toner cartridge is not installed properly.	Pull out the drum unit and remove the toner cartridge, then re-install the toner cartridge in the drum unit.
Comm.Error	Poor telephone line quality caused a communication error.	Send the fax again or connect the machine to another telephone line. If the problem continues, call the telephone company and ask them to check your telephone line.
Connection Fail	You tried to poll a fax machine that is not in Polled Waiting mode.	Check the other fax machine's polling setup.
Cooling Down Wait for a while	The temperature of the drum unit or toner cartridge is too hot. The machine will pause its current print job and go into cooling down mode. During the cooling down mode, you will hear the cooling fan running while the LCD shows Cooling Down, and Wait for a while.	Make sure that you can hear the fan in the machine spinning and that the exhaust outlet is not blocked by something. If the fan is spinning, remove any obstacles that surround the exhaust outlet, and then leave the machine turned on but do not use it for several minutes. If the fan is not spinning do one of the following: (For MFC-7360N and MFC-7460DN) See <i>Transferring your faxes or Fax Journal report</i> on page 69 before disconnecting the machine so you will not lose any important messages. Then, disconnect the machine from the power for several minutes and then reconnect it. (For MFC-7860DW) Disconnect the machine from the AC power outlet for several minutes, then reconnect it.

Error Message	Cause	Action
Cover is Open	The front cover is not completely closed.	Close the front cover of the machine.
Cover is Open	The ADF cover is not completely closed.	Close the ADF cover of the machine.
	The ADF is open while loading a document.	Close the ADF cover of the machine, then press Stop/Exit .
Cover is Open	The fuser cover is not completely closed or paper was jammed in the back of the machine when you turned on the power.	<ul style="list-style-type: none"> ■ Close the fuser cover of the machine. ■ Make sure paper is not jammed inside the back of the machine, and then close the fuser cover and press Start.
Disconnected	The other person or other person's fax machine stopped the call.	Try to send or receive again.
Document Jam	The document was not inserted or fed properly, or the document scanned from the ADF was too long.	See <i>Document is jammed in the top of the ADF unit</i> on page 70 or <i>Using the automatic document feeder (ADF)</i> on page 22.
DR Mode in Use	The machine is set to Distinctive Ring mode. You cannot change the Receive Mode from Manual to another mode.	Set Distinctive Ring to Off . (See <i>Turning off Distinctive Ring</i> on page 34.)
Drum Error	The corona wire on the drum unit needs to be cleaned.	Clean the corona wire on the drum unit. (See <i>Cleaning the corona wire</i> on page 58.)
Drum Stop	It is time to replace the drum unit.	Replace the drum unit. (See <i>Replacing the drum unit</i> on page 59.)
Duplex Disabled	The duplex tray is removed or is not properly installed.	Carefully put the duplex tray into the machine until it clicks into place.
	The back of the machine is not closed completely.	Close the back cover of the machine.
EL Error	The machine has a mechanical problem.	Open the front cover and close it again.
Fuser Error	The temperature of the fuser unit does not rise to a specified temperature within the specified time.	<p>(For MFC-7360N and MFC-7460DN) Received fax messages still in memory will be lost when the machine is turned off. See <i>Transferring your faxes or Fax Journal report</i> on page 69 before disconnecting the machine so you will not lose any important messages. Then, turn the power switch off, wait a few seconds, and then turn it on again. Leave the machine for 15 minutes with the power on.</p> <p>(For MFC-7860DW) Turn the power switch off, wait a few seconds, and then turn it on again. Leave the machine for 15 minutes with the power on.</p>
	The fuser unit is too hot.	



Error Message	Cause	Action
Init Unable XX	The machine has a mechanical problem.	<ul style="list-style-type: none"> ■ (For MFC-7360N and MFC-7460DN) Received fax messages still in memory will be lost when the machine is turned off. See <i>Transferring your faxes or Fax Journal report</i> on page 69 before disconnecting the machine so you will not lose any important messages. Then, disconnect the machine from the power for several minutes and then reconnect it. (For MFC-7860DW) Disconnect the machine from the power for several minutes, then reconnect it. ■ If the problem continues, call Brother Customer Service.
Jam Duplex	The paper is jammed in the duplex tray at the back of the machine.	(See <i>Paper is jammed in the Duplex Tray (MFC-7460DN and MFC-7860DW)</i> on page 80.)
Jam Inside	The paper is jammed inside the machine.	(See <i>Paper is jammed inside the machine</i> on page 75.)
Jam Rear	The paper is jammed in the back of the machine.	(See <i>Paper is jammed at the back of the machine</i> on page 73.)
Jam Tray	The paper is jammed in the paper tray of the machine.	(See <i>Paper is jammed in the standard paper tray</i> on page 72.)
Limit Exceeded	The Page Limit set in Secure Function Lock 2.0 for your ID was reached.	Contact your administrator to check your Secure Function Lock Settings.
Manual Feed	Manual Feed was selected as the paper source when there was no paper in the manual feed slot.	Place a sheet of paper in the manual feed slot. (See <i>Loading paper in the manual feed slot</i> on page 11.)
No Paper	The machine is out of paper or paper is not properly loaded in the paper tray.	<p>Do one of the following:</p> <ul style="list-style-type: none"> ■ Refill the paper in the paper tray and press Start. ■ Remove the paper and load it again. Then press Start. ■ If the problem is not resolved, the paper pick-up roller may need to be cleaned. Clean the paper pick-up roller. (See <i>Cleaning the paper pick-up rollers in Appendix A of the Advanced User's Guide.</i>)
No Response/Busy	The number you dialed does not answer or is busy.	Verify the number and try again.
No Toner	The toner cartridge is not installed correctly.	Pull out the drum unit. Take out the toner cartridge and then put it back into the drum unit.

Error Message	Cause	Action
Not Available	The requested function is not permitted to all IDs by Secure Function Lock 2.0.	Contact your administrator to check your Secure Function Lock Settings.
Out of Memory	The machine's memory is full.	<p>Fax sending or copy operation in progress</p> <p>Do one of the following:</p> <ul style="list-style-type: none"> ■ Press Start to send or copy the scanned pages. ■ Press Stop/Exit and wait until the other operations in progress finish, and then try again. ■ Clear the faxes from the memory. <p>Print the faxes that are stored in the memory to restore the memory to 100%. Then turn off Fax Storage to avoid storing more faxes in the memory. (See <i>Printing a fax from the memory</i> in Chapter 4 of the <i>Advanced User's Guide</i> and <i>Fax Storage</i> in Chapter 4 of the <i>Advanced User's Guide</i>.)</p> <p>Print operation in process</p> <p>Do one of the following:</p> <ul style="list-style-type: none"> ■ Reduce the print resolution. (See <i>Basic tab</i> in the <i>Software User's Guide</i>.) ■ Clear the faxes from the memory. (See the above explanation.)
Print Unable XX	The machine has a mechanical problem.	<p>Do one of the following:</p> <ul style="list-style-type: none"> ■ (For MFC-7360N and MFC-7460DN) <i>Transferring your faxes or Fax Journal report</i> on page 69 before disconnecting the machine so you will not lose any important messages. Then, disconnect the machine from the power for several minutes and then reconnect it. <p>(For MFC-7860DW) Disconnect the machine from the power for several minutes, then reconnect it.</p> <ul style="list-style-type: none"> ■ If the problem continues, call Brother Customer Service.
Replace Drum	It is time to replace the drum unit.	<p>Replace the drum unit.</p> <p>(See <i>Replacing the drum unit</i> on page 59.)</p>
	The drum unit counter was not reset when a new drum was installed.	<p>Reset the drum unit counter.</p> <p>(See <i>Replacing the drum unit</i> on page 60.)</p>



Error Message	Cause	Action
Replace Toner	The machine will stop printing until you replace the toner cartridge.	<p>If you have set the Toner setting to <i>Stop</i>, replace the toner cartridge with a new and unused original Brother toner cartridge. This will reset the Replace Toner mode. (See <i>Replacing the toner cartridge</i> on page 53.)</p> <p>If you have set the Toner setting to <i>Continue</i>, the machine will continue to print data until the LCD shows <i>Toner Ended</i>. For how to operate the machine in Continue mode, see <i>Toner Settings</i> in <i>Chapter 1</i> of the <i>Advanced User's Guide</i>.</p>
Scan Unable XX	The machine has a mechanical problem.	<ul style="list-style-type: none"> ■ (For MFC-7360N and MFC-7460DN) See <i>Transferring your faxes or Fax Journal report</i> on page 69 before disconnecting the machine so you will not lose any important messages. Then, disconnect the machine from the power for several minutes and then reconnect it. <p>(For MFC-7860DW) Disconnect the machine from the power for several minutes, then reconnect it.</p> <ul style="list-style-type: none"> ■ If the problem continues, call Brother Customer Service.
Size Error DX	The paper in the tray is not a suitable size for automatic duplex printing.	Load either Letter, Legal or Folio paper for automatic duplex printing, and then press Start . (See <i>Print media</i> on page 127.)
Size mismatch	The paper in the tray is not a correct size.	Load an appropriate size of paper in the tray, and re-set the "Paper Size" (Menu, 1, 2, 2). (See <i>Paper Size</i> on page 17.)
Toner Ended	It is time to replace the toner cartridge.	Replace the toner cartridge with a new one. (See <i>Replacing the toner cartridge</i> on page 53.)
Toner Low	The toner is low.	Buy a new toner cartridge before you get a Replace Toner message.

Transferring your faxes or Fax Journal report

If the LCD shows:

- Init Unable XX
- Print Unable XX
- Scan Unable XX

(MFC-7360N and MFC-7460DN)

If it is necessary to disconnect the machine from the AC power outlet, we recommend transferring your faxes to another fax machine or to your PC before you unplug the machine. (See *Transferring faxes to another fax machine* on page 69 or *Transferring faxes to your PC* on page 69.)

You can also transfer the Fax Journal report to see if there are any faxes you need to transfer. (See *Transferring Fax Journal report to another fax machine* on page 69.)



Note

If there is an error message on the machine's LCD, after the faxes have been transferred, disconnect the machine from the power source for several minutes, and then reconnect it.

Transferring faxes to another fax machine

If you have not set up your Station ID, you cannot enter fax transfer mode. (See *Set your station ID* in the *Quick Setup Guide*.)

- 1 Press **Menu, 9, 0, 1**.
- 2 Do one of the following:
 - If the LCD shows **No Data**, there are no faxes left in the machine's memory. Press **Stop/Exit**.
 - Enter the fax number to which faxes will be forwarded.
- 3 Press **Start**.

Transferring faxes to your PC

You can transfer the faxes from your machine's memory to your PC.

- 1 Make sure that you have installed **MFL-Pro Suite** on your PC, and then turn on **PC-Fax Receiving** on the PC. (For details about PC-Fax Receive, see *PC-FAX receiving* in the *Software User's Guide*.)
- 2 Make sure that you have set **PC Fax Receive** on the machine. (See *PC-Fax Receive* in *Chapter 4* of the *Advanced User's Guide*.)
If faxes are in the machine's memory when you set up PC-Fax Receive, the LCD will ask if you want to transfer the faxes to your PC.
- 3 Do one of the following:
 - To transfer all faxes to your PC, press **1**. You will be asked if you want a backup print.
 - To exit and leave the faxes in the memory, press **2**.
- 4 Press **Stop/Exit**.

Transferring Fax Journal report to another fax machine

If you have not set up your Station ID, you cannot enter fax transfer mode. (See *Set your station ID* in the *Quick Setup Guide*.)

- 1 Press **Menu, 9, 0, 2**.
- 2 Enter the fax number to which the Fax Journal report will be forwarded.
- 3 Press **Start**.

Document Jams

Document is jammed in the top of the ADF unit

- 1 Take out any paper from the ADF that is not jammed.
- 2 Open the ADF cover.
- 3 Pull the jammed document out to the left.

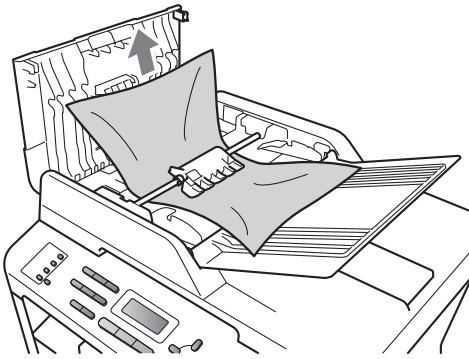

- 4 Close the ADF cover.
- 5 Press **Stop/Exit**.

Document is jammed under the document cover

- 1 Take out any paper from the ADF that is not jammed.
- 2 Lift the document cover.
- 3 Pull the jammed document out to the right.

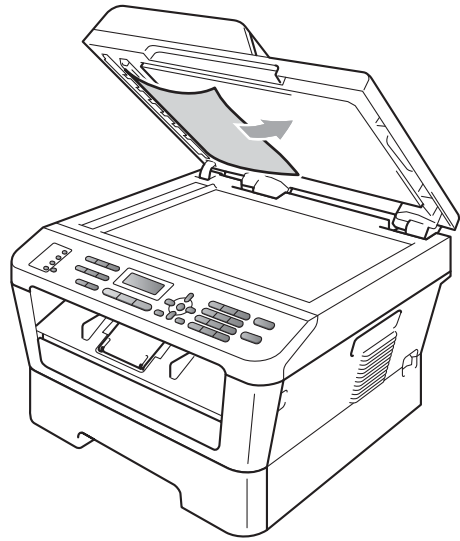

- 4 Close the document cover.
- 5 Press **Stop/Exit**.

Removing small documents jammed in the ADF

- 1 Lift the document cover.
- 2 Insert a piece of stiff paper, such as cardstock, into the ADF to push any small paper scraps through.

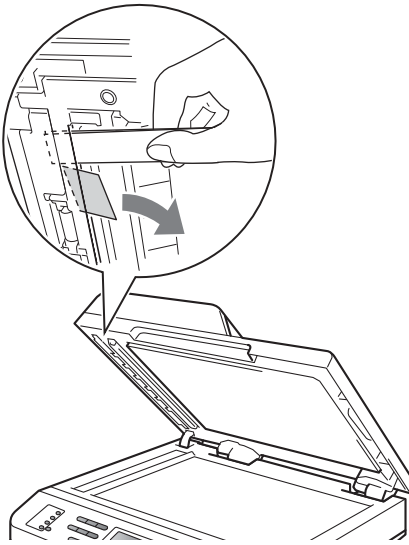

- 3 Close the document cover.
- 4 Press **Stop/Exit**.

Document is jammed at the output tray

- 1 Take out any paper from the ADF that is not jammed.
- 2 Pull the jammed document out to the right.

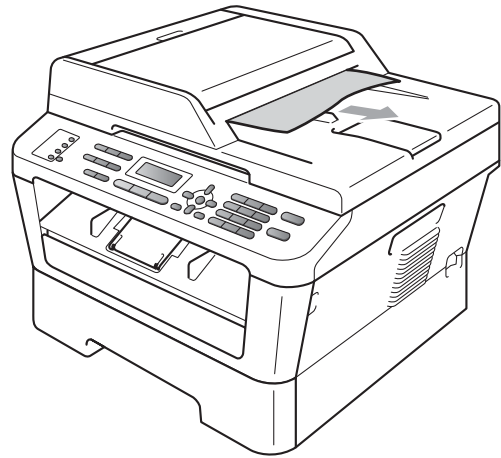

- 3 Press **Stop/Exit**.

Paper Jams

Paper is jammed in the standard paper tray

If the LCD shows Jam Tray, follow these steps:

- 1 Pull the paper tray completely out of the machine.

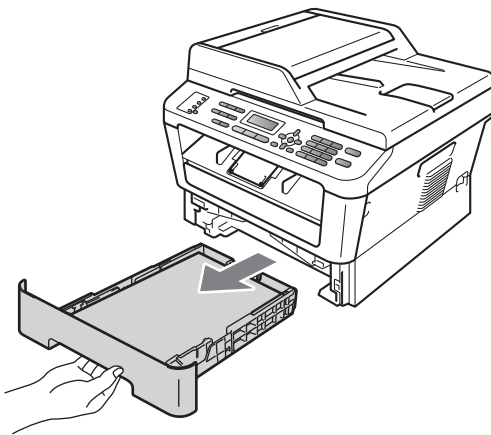

- 2 Use both hands to slowly pull out the jammed paper.

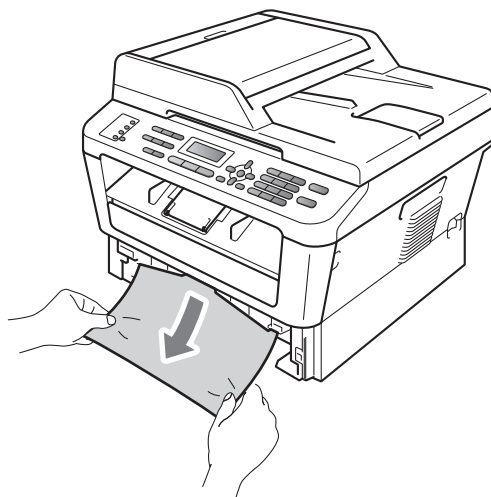

! IMPORTANT

If the paper cannot easily be removed in this direction, stop and follow the instructions for *Paper is jammed inside the machine* on page 75.

Note

Pulling out the jammed paper downwards allows you to remove the paper more easily.

- 3 Make sure the paper is below the maximum paper mark (▼▼▼) (1) of the paper tray. While pressing the green paper-guide release lever, slide the paper guides to fit the paper size. Make sure that the guides are firmly in the slots. (See *Loading paper in the standard paper tray* on page 9.)

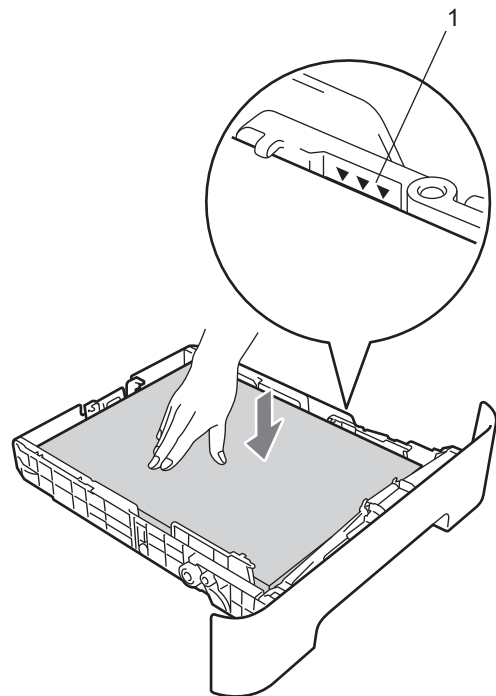

- 4 Put the paper tray firmly back in the machine.

Paper is jammed at the back of the machine

If the LCD shows **Jam Rear**, a paper jam occurred behind the back cover. Follow these steps:

- 1 Open the front cover. Leave the machine turned on for 10 minutes to cool down.

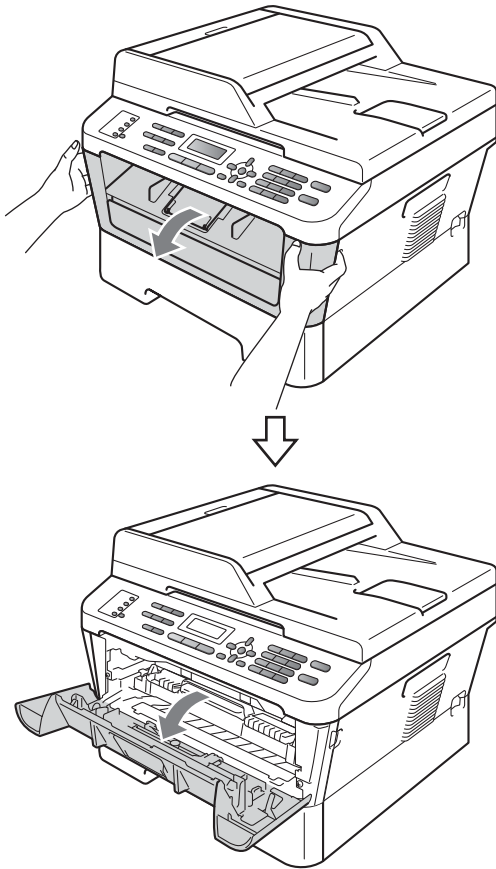

WARNING

HOT SURFACE

After you have just used the machine, some internal parts of the machine will be extremely hot. Wait for the machine to cool down before you touch the internal parts of the machine.

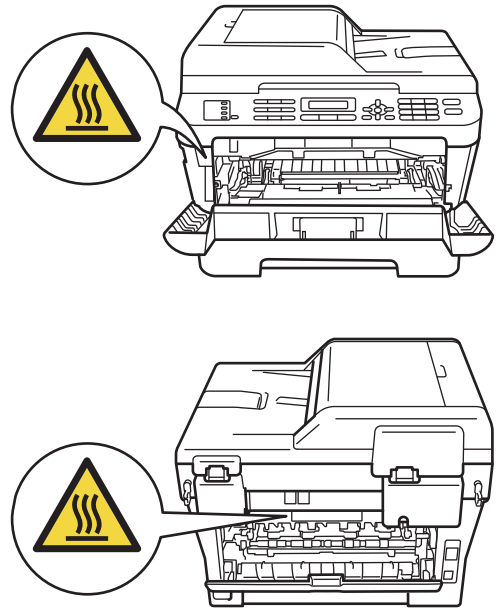

- 2 Slowly take out the drum unit and toner cartridge assembly.

B

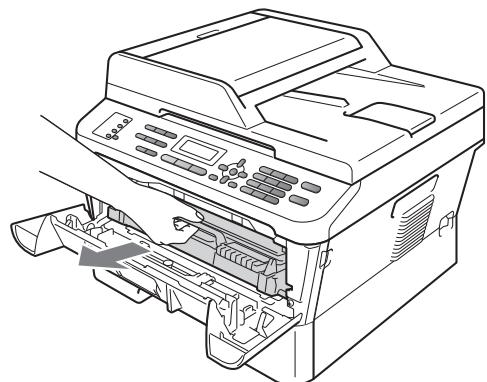

! IMPORTANT

- We recommend that you place the drum unit and the toner cartridge on a clean, flat surface with a sheet of disposable paper or cloth underneath it in case you accidentally spill or scatter toner.
- To prevent damage to the machine caused by static electricity, DO NOT touch the electrodes shown in the illustration.

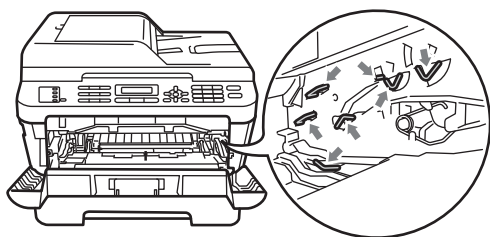

- 3 Open the back cover (face-up output tray).

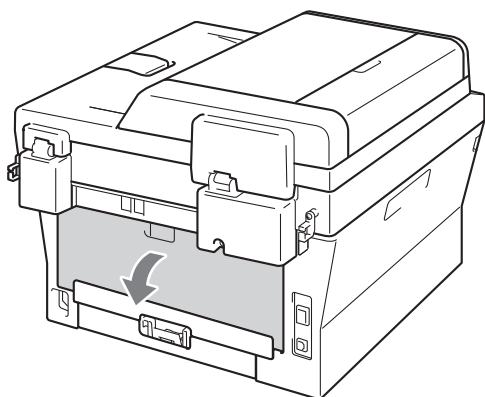

- 4 Pull down the tabs at the left and right hand sides to open the fuser cover (1).

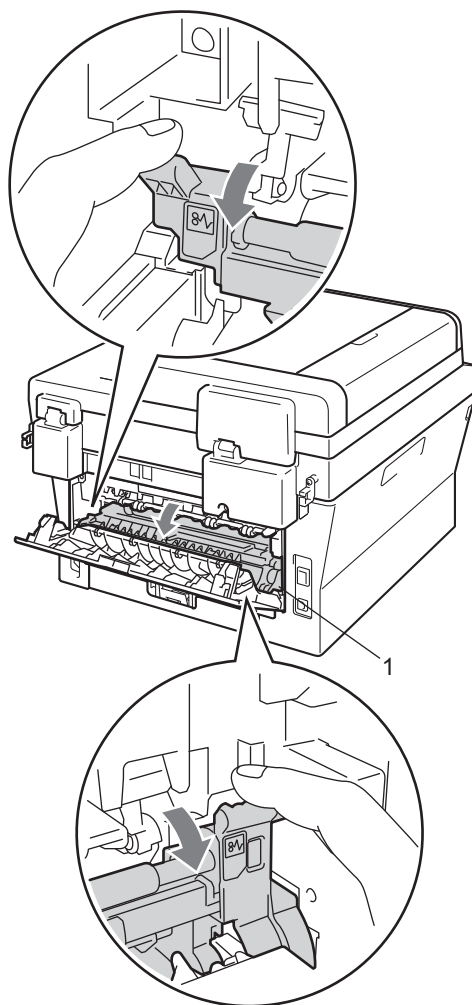

- Using both hands, gently pull the jammed paper out of the fuser unit.

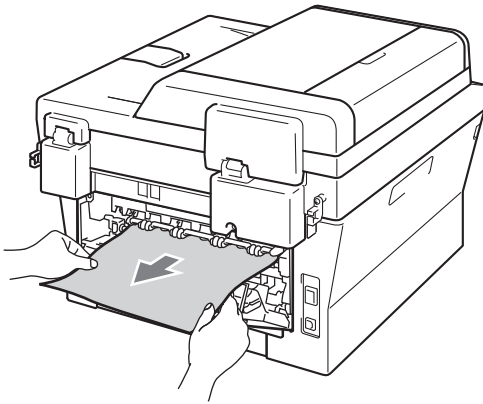

- Close the fuser cover and the back cover (face-up output tray).
- Put the drum unit and toner cartridge assembly back into the machine.

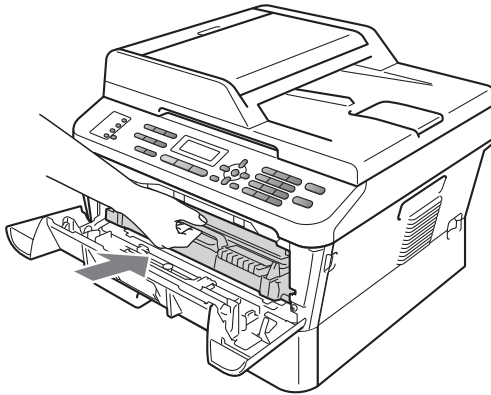

- Close the front cover. If the machine does not start printing automatically, press **Start**.

Paper is jammed inside the machine

If the LCD shows `Jam Inside`, follow these steps:

- Open the front cover. Leave the machine turned on for 10 minutes to cool down.

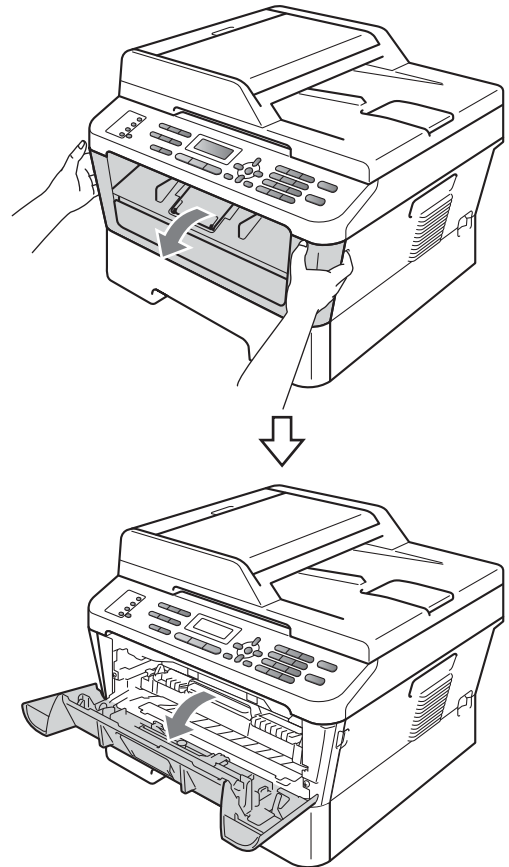

B

WARNING

HOT SURFACE

After you have just used the machine, some internal parts of the machine will be extremely hot. Wait for the machine to cool down before you touch the internal parts of the machine.

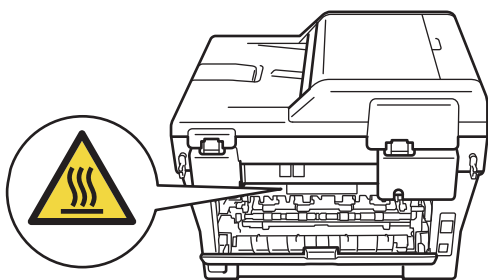
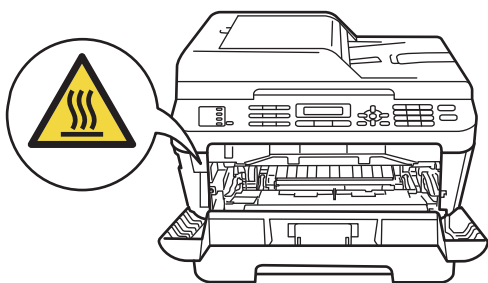

- 2 Slowly take out the drum unit and toner cartridge assembly. The jammed paper may be pulled out with the drum unit and toner cartridge assembly, or this may release the paper so you can pull it out inside of the machine.

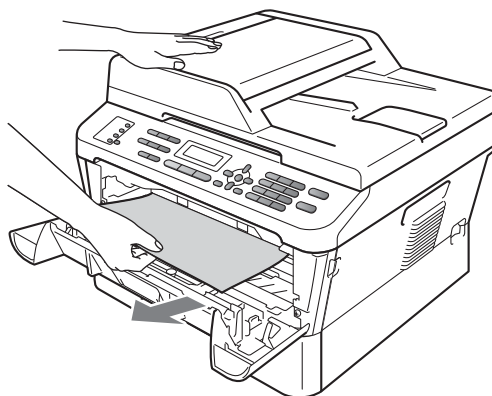
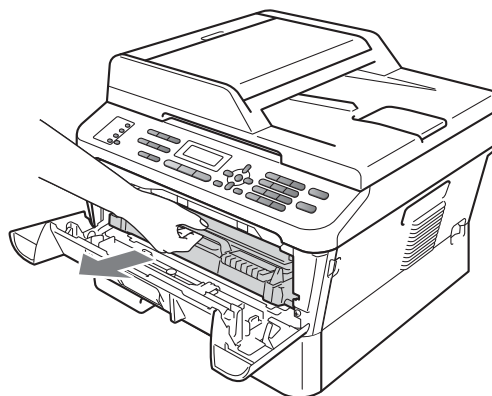

! IMPORTANT

- We recommend that you put the drum unit and toner cartridge assembly on a piece of disposable paper or cloth in case you accidentally spill or scatter toner.
- To prevent damage to the machine from static electricity, **DO NOT** touch the electrodes shown in the illustration.

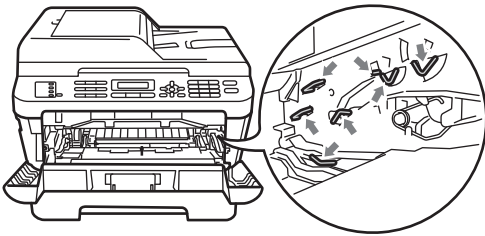

! IMPORTANT

- Handle the toner cartridge carefully. If toner scatters on your hands or clothes, immediately wipe or wash it off with cold water.

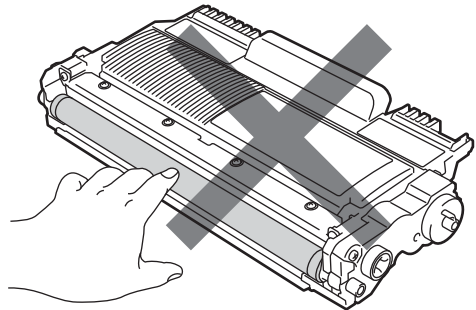

- To avoid print quality problems, **DO NOT** touch the shaded parts shown in the illustrations.

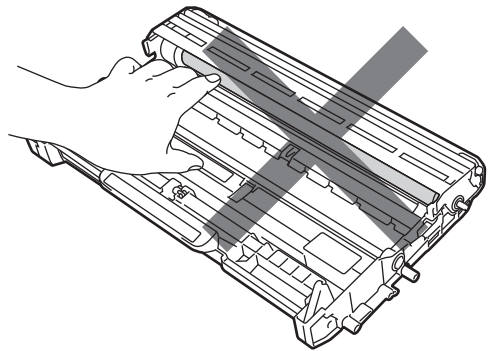

- 3 Push down the green lock lever and take the toner cartridge out of the drum unit. Clear the jammed paper if there is any inside the drum unit.

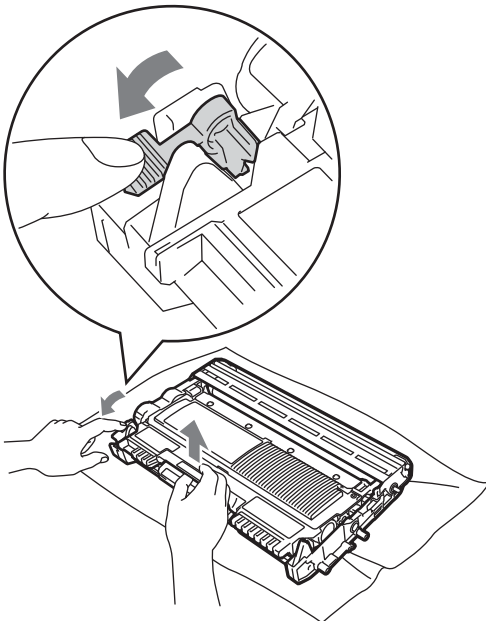

- 4 Put the toner cartridge back into the drum unit until you hear it lock into place. If you put the cartridge properly, the green lock lever will lift automatically.

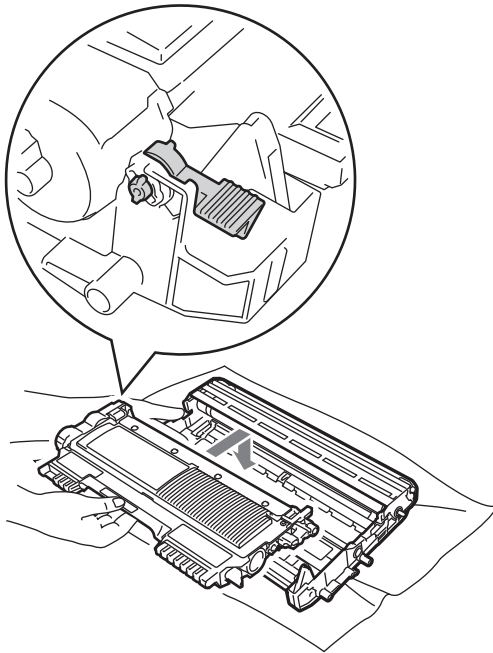
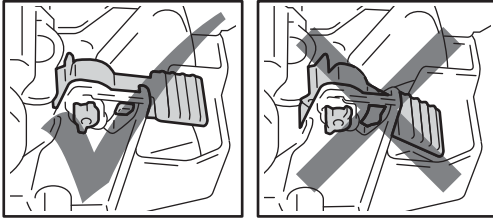

- 5 Do one of the following:
- If you were able to remove the drum unit and toner cartridge assembly and the jammed paper, then go to step 10.
 - If you can not remove the drum unit and toner cartridge assembly easily, do not use extra force. Instead, lift the scanner cover.

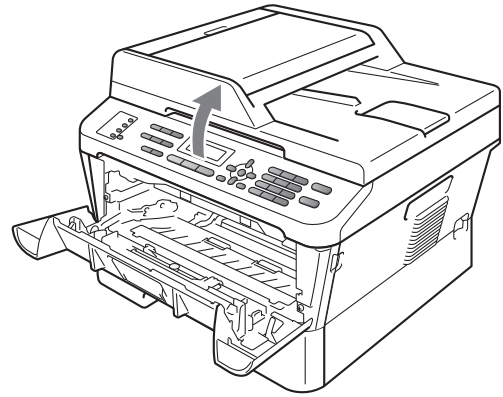

Use both hands to carefully pull the jammed paper up and out of the output tray opening.

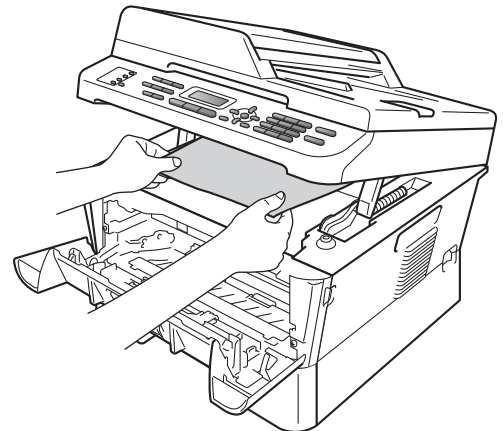

- 6 Close the scanner cover.

- 7 If you could not pull the jammed paper out of the inside of the machine as shown in the step 6, take the paper tray completely out of the machine.

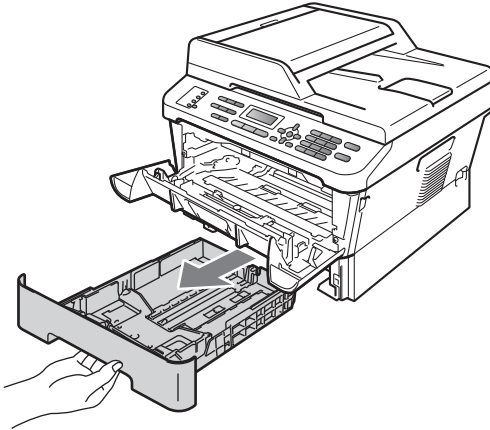

- 8 Pull the jammed paper out of the paper tray opening.

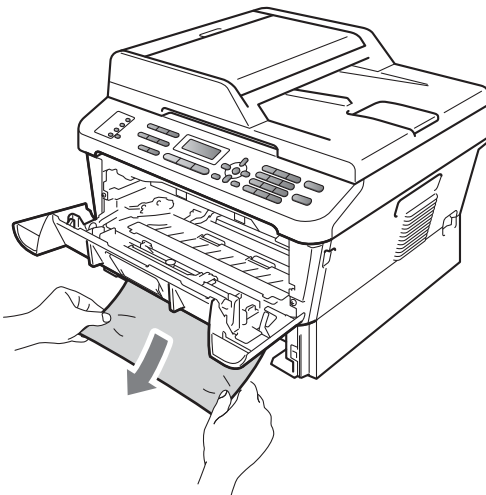

- 9 Put the paper tray back in the machine.

- 10 Put the drum unit and toner cartridge assembly back in the machine.

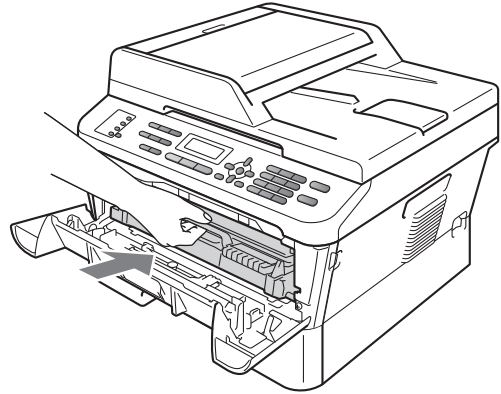

- 11 Close the front cover of the machine. If the machine does not start printing automatically, press **Start**.



Note

If you turn off the machine while the LCD shows **Jam Inside**, the machine will print incomplete data from your computer.

Paper is jammed in the Duplex Tray (MFC-7460DN and MFC-7860DW)

If the LCD shows `Jam Duplex`, follow these steps:

- 1 Leave the machine turned on for 10 minutes to cool down.

WARNING

HOT SURFACE

After you have just used the machine, some internal parts of the machine will be extremely hot. Wait for the machine to cool down before you touch the internal parts of the machine.

- 2 Pull the duplex tray completely out of the machine.

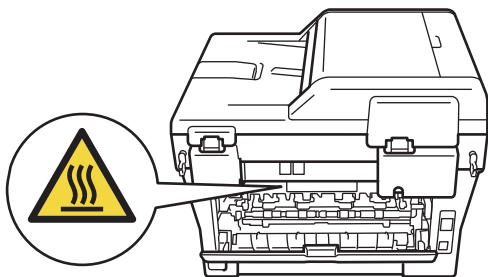
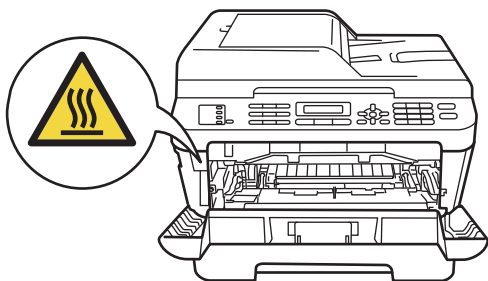
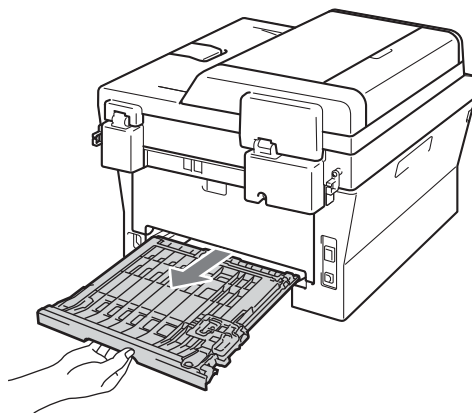

- 3 Pull the jammed paper out of the machine or the duplex tray.

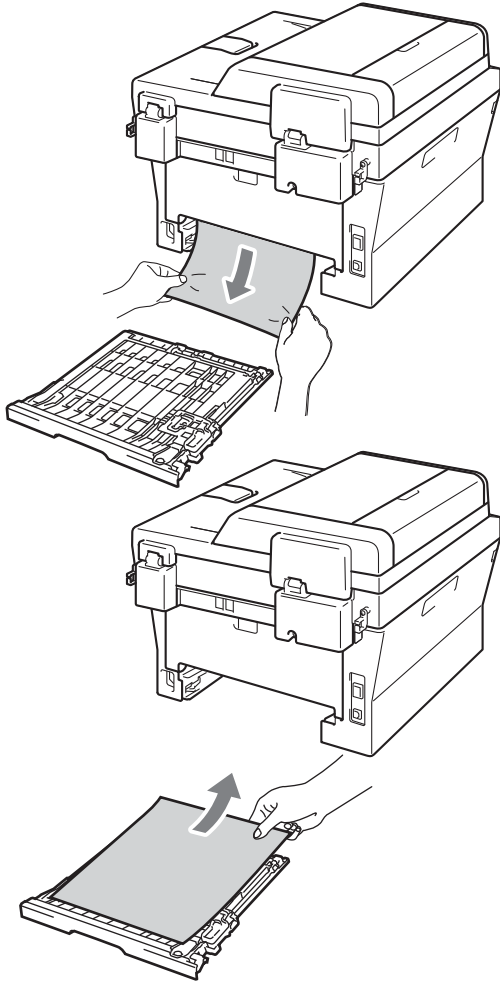

- 4 Make sure that the jammed paper does not remain under the machine from static electricity.

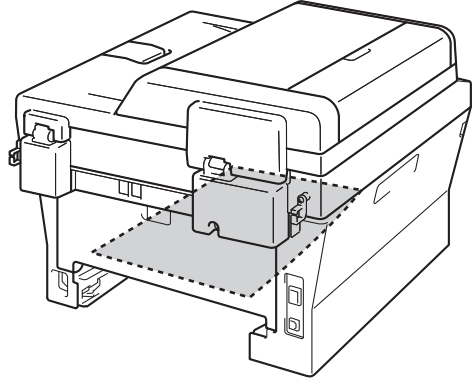

- 5 Put the duplex tray back in the machine.

If you are having difficulty with your machine

! IMPORTANT

For technical help, you must call the country where you bought the machine. Calls must be made **from within** that country.

If you think there is a problem, check the chart below and follow the troubleshooting tips. You can solve most problems by yourself.

If you need additional help, the Brother Solutions Center offers the latest FAQs and troubleshooting tips.

Visit us at <http://solutions.brother.com/>.

Printing or printing received faxes

Difficulties	Suggestions
<ul style="list-style-type: none"> ■ Condensed print ■ Horizontal streaks ■ Top and bottom sentences are cut off ■ Missing lines 	Usually this is caused by a poor telephone connection. If your copy looks good, you probably had a bad connection, with static or interference on the telephone line. Ask the other party to send the fax again.
Poor print quality	See <i>Improving the print quality</i> on page 92.
Vertical black lines when receiving	The corona wire for printing may be dirty. Clean the corona wire on the drum unit. (See <i>Cleaning the corona wire</i> on page 58.)
	The sender's scanner may be dirty. Ask the sender to make a copy to see if the problem is with the sending machine. Try receiving from another fax machine.
	If the problem continues, call Brother Customer Service at 1-877-BROTHER (1-877-276-8437) (in USA) or 1-877-BROTHER (in Canada).
Received faxes appear as split or blank pages.	If the received faxes are divided and printed on two pages or if you get an extra blank page, your paper size setting may not be correct for the paper you are using. (See <i>Paper Size</i> on page 17.)
	Turn on Auto Reduction. (See <i>Printing a reduced incoming fax</i> in Chapter 4 of the <i>Advanced User's Guide</i> .)

Telephone line or connections

Difficulties	Suggestions
Dialing does not work.	Check for a dial tone.
	Change Tone/Pulse setting. (See the <i>Quick Setup Guide</i> .) (Canada only)
	Check all line cord connections.
	Check that the machine is plugged in and switched on.
	Send a manual fax by pressing Hook or by lifting the handset of the external telephone and dialing the number. Wait to hear fax receiving tones before pressing Start .

Telephone line or connections (continued)

Difficulties	Suggestions
The machine does not answer when called.	Make sure the machine is in the correct receive mode for your setup. (See <i>Receive Mode settings</i> on page 30.) Check for a dial tone. If possible, call your machine to hear it answer. If there is still no answer, check the telephone line cord connection. If you do not hear ringing when you call your machine, ask your telephone company to check the line.

Receiving Faxes

Difficulties	Suggestions
Cannot receive a fax.	Make sure your machine has a dial tone by pressing the Hook key. If you hear static or interference on your fax line, please contact your local telephone company.
	Check all line cord connections. Make sure the telephone line cord is plugged into the telephone wall jack and the LINE jack of the machine. If you subscribe to DSL or VoIP services, please contact your service provider for connection instructions.
	Make sure the machine is in the correct Receive Mode. This is determined by the external devices and telephone subscriber services you have on the same line as the Brother machine. (See <i>Receive Mode settings</i> on page 30.)
	If you have a dedicated fax line and want your Brother machine to automatically answer all incoming faxes, you should select Fax Only mode.
	If your Brother machine shares a line with an external answering machine, you should select the External TAD mode. In External TAD mode, your Brother machine will automatically receive incoming faxes and voice callers will be able to leave a message on your answering machine.
	If your Brother machine shares the line with a Voice Mail subscriber service, please see <i>Voice Mail</i> on page 32.
	If your Brother machine is on a line with the Distinctive Ring subscriber service, please see <i>Distinctive Ring</i> on page 32.
If your Brother machine shares a line with other telephones and you want it to automatically answer all incoming faxes, you should select the Fax/Tel mode. In Fax/Tel mode, your Brother machine will automatically receive faxes and produce a pseudo/double-ring to alert you to answer voice calls.	
If you do not want your Brother machine to automatically answer any incoming faxes, you should select the Manual mode. In Manual mode, you must answer every incoming call and activate the machine to receive faxes.	

Receiving Faxes (continued)

Difficulties	Suggestions
<p>Cannot receive a fax. (continued)</p>	<p>Another device or service at your location may be answering the call before your Brother machine answers. To test this, lower the ring delay setting:</p> <ul style="list-style-type: none"> ■ If the answer mode is set to Fax Only or Fax/Tel, reduce the ring delay to 1 ring. (See <i>Ring Delay</i> on page 30.) ■ If the answer mode is set to External TAD, reduce the number of rings programmed on your answering machine to 2. ■ If the answer mode is set to Manual, DO NOT adjust the ring delay setting. <p>Have someone send you a test fax:</p> <ul style="list-style-type: none"> ■ If you received the test fax successfully, your machine is operating properly. Remember to reset your ring delay or answering machine setting back to your original setting. If receiving problems recur after resetting the ring delay, then a person, device, or subscriber service is answering the fax call before the machine has a chance to answer. ■ If you were not able to receive the fax, then another device or subscriber service may be interfering with your fax reception or there may be a problem with your fax line. <p>If you are using a telephone answering machine (External TAD mode) on the same line as the Brother machine, make sure your answering machine is set up correctly. (See <i>Connecting an external TAD (telephone answering device)</i> on page 35.)</p> <ol style="list-style-type: none"> 1 Plug the telephone line cord directly from the wall telephone jack to your Brother machine's LINE jack. 2 Remove the protective cap from your Brother machine's EXT jack, and then plug the telephone line cord from your answering machine into the EXT jack. 3 Set your answering machine to answer within 4 rings. If you are having problems receiving faxes or voice messages, set your answering machine to answer within 2 or 3 rings. 4 Record the outgoing message on your answering machine. <ul style="list-style-type: none"> ■ Record five seconds of silence at the beginning of your outgoing message. ■ Limit your speaking to 20 seconds. ■ End your outgoing message with your Fax Receive Code for people sending manual faxes. For example: "After the beep, leave a message or press *51 and Start to send a fax." 5 Set your answering machine to answer calls. 6 Set your Brother machine's Receive Mode to External TAD. (See <i>Receive Mode settings</i> on page 30.) <p>Make sure your Brother machine's Easy Receive feature is turned On. Easy Receive is a feature that allows you to receive a fax even if you have answered the call on an external or extension telephone. (See <i>Easy Receive</i> on page 31.)</p> <p>If you often get transmission errors due to possible interference on the telephone line, try changing the Compatibility setting to Basic (for VoIP). (See <i>Telephone line interference</i> on page 91.)</p> <p>(For MFC-7860DW) Contact your administrator to check your Secure Function Lock Settings.</p>

Sending faxes

Difficulties	Suggestions
Poor sending quality.	Try changing your resolution to <i>Fine</i> or <i>S.Fine</i> . Make a copy to check your machine's scanner operation. If the copy quality is not good, clean the scanner. (See <i>Cleaning the scanner</i> in <i>Appendix A</i> of the <i>Advanced User's Guide</i> .)
Transmission Verification Report says RESULTING .	There is probably temporary noise or static on the line. Try sending the fax again. If you are sending a PC-Fax message and get RESULTING on the Transmission Verification Report, your machine may be out of memory. To free up extra memory, you can turn off fax storage (see <i>Changing Remote Fax Options</i> in <i>Chapter 4</i> of the <i>Advanced User's Guide</i>), print fax messages in memory (see <i>Printing a fax from the memory</i> in <i>Chapter 4</i> of the <i>Advanced User's Guide</i>) or cancel a delayed fax or polling job (see <i>Checking and canceling waiting jobs</i> in <i>Chapter 3</i> of the <i>Advanced User's Guide</i>). If the problem continues, ask the telephone company to check your telephone line. If you often get transmission errors due to possible interference on the telephone line, try changing the Compatibility setting to <i>Basic</i> (for VoIP). (See <i>Telephone line interference</i> on page 91.)
Sent faxes are blank.	Make sure you are loading the document properly. (See <i>Loading documents</i> on page 22.)
Vertical black lines when sending.	Black vertical lines on faxes you send are typically caused by dirt or correction fluid on the glass strip. (See <i>Cleaning the scanner</i> in <i>Appendix A</i> of the <i>Advanced User's Guide</i> .)
Cannot send a fax.	(For MFC-7860DW) Contact your administrator to check your Secure Function Lock Settings.

Handling incoming calls

Difficulties	Suggestions
The machine 'hears' a voice as a CNG tone.	If Easy Receive is set to On, your machine is more sensitive to sounds. It may mistakenly interpret certain voices or music on the line as a fax machine calling and respond with fax receiving tones. Deactivate the machine by pressing Stop/Exit . Try avoiding this problem by turning Easy Receive to Off. (See <i>Easy Receive</i> on page 31.)
Sending a fax call to the machine.	If you answered on an external or extension telephone, press your Fax Receive Code (default setting is *51). When your machine answers, hang up.
Custom features on a single line.	If you have Call Waiting, Call Waiting/Caller ID, Caller ID, RingMaster, Voice Mail, an answering machine, an alarm system or other custom feature on a single telephone line with your machine, it may create a problem sending or receiving faxes. For Example: If you subscribe to Call Waiting or some other custom service and its signal comes through the line while your machine is sending or receiving a fax, the signal can temporarily interrupt or disrupt the faxes. Brother's ECM feature should help overcome this problem. This condition is related to the telephone system industry and is common to all devices that send and receive information on a single, shared line with custom features. If avoiding a slight interruption is crucial to your business, a separate line with no custom features is recommended.

B

Menu access difficulties

Difficulties	Suggestions
The machine beeps when you try to access the Setup Receive and Setup Send menus.	If FAX  is not illuminated, press it to turn on Fax mode. The Setup Receive settings (Menu, 2, 1) and Setup Send settings (Menu, 2, 2) are available only when the machine is in Fax mode.

Copy difficulties

Difficulties	Suggestions
Cannot make a copy.	<ul style="list-style-type: none"> ■ Make sure that COPY  is illuminated. (See <i>How to copy</i> on page 48.) ■ (For MFC-7860DW) Contact your administrator to check your Secure Function Lock Settings.
Vertical black line appears in copies.	Black vertical lines on copies are typically caused by dirt or correction fluid on the glass strip, or the corona wire is dirty. (See <i>Cleaning the scanner</i> in <i>Appendix A</i> of the <i>Advanced User's Guide</i> and <i>Cleaning the corona wire</i> on page 58.)
Copies are blank.	Make sure you are loading the document properly. (See <i>Using the automatic document feeder (ADF)</i> on page 22 or <i>Using the scanner glass</i> on page 23.)

Printing difficulties

Difficulties	Suggestions
No printout.	<ul style="list-style-type: none"> ■ Check that the machine is plugged in and the power switch is turned on. ■ Check that the toner cartridge and drum unit are installed properly. (See <i>Replacing the drum unit</i> on page 59.) ■ Check the interface cable connection on both the machine and your computer. (See the <i>Quick Setup Guide</i>.) ■ Check that the correct printer driver has been installed and chosen. ■ Check to see if the LCD is showing an error message. (See <i>Error and maintenance messages</i> on page 64.) ■ Check that the machine is online: (Windows® 7 and Windows Server® 2008 R2) Click the Start button and Devices and Printers. Right-click Brother MFC-XXXX Printer. Make sure that Use Printer Offline is unchecked. (Windows Vista®) Click the Start button, Control Panel, Hardware and Sound, and then Printers. Right-click Brother MFC-XXXX Printer. Make sure that Use Printer Offline is unchecked. (Windows® XP and Windows Server® 2003/2008) Click the Start button and choose Printers and Faxes. Right-click Brother MFC-XXXX Printer. Make sure that Use Printer Offline is unchecked. (Windows® 2000) Click the Start button and choose Settings and then Printers. Right-click Brother MFC-XXXX Printer. Make sure that Use Printer Offline is unchecked. ■ (For MFC-7860DW) Contact your administrator to check your Secure Function Lock settings.

Printing difficulties (continued)

Difficulties	Suggestions
The machine prints unexpectedly or it prints garbage.	<ul style="list-style-type: none"> ■ Press Job Cancel to cancel print jobs. ■ Check the settings in your application to make sure it is set up to work with your machine. ■ Pull out the paper tray and wait until the machine stops printing. Then turn off the machine's power switch and disconnect from the power for several minutes. (For MFC-7360N and MFC-7460DN) The faxes stored in the machine memory will be deleted. See <i>Transferring your faxes or Fax Journal report</i> on page 69 before disconnecting the machine so you will not lose any important messages.
The machine prints the first couple of pages correctly, then some pages have text missing.	<ul style="list-style-type: none"> ■ Check the settings in your application to make sure that it is set up to work with your machine. ■ Your computer is not recognizing the machine's input buffer's full signal. Make sure that you connected the interface cable correctly. (See the <i>Quick Setup Guide</i>.)
The headers or footers appear when the document displays on the screen but they do not show up when it is printed.	There is an unprintable area on the top and bottom of the page. Adjust the top and bottom margins in your document to allow for this. (See <i>Unscannable and unprintable areas</i> on page 16.)
The machine does not print on both sides of the paper even though the printer driver setting is Duplex.	Check the paper size setting in the printer driver. You need to choose Letter, Legal or Folio [16 to 28 lb (60 to 105 g/m ²)].
The machine is not printing or has stopped printing.	<p>Press Job Cancel.</p> <p>As the machine cancels the job and clears it from the memory it may produce an incomplete printout.</p>

Scanning difficulties

Difficulties	Suggestions
TWAIN errors appear while scanning.	Make sure that the Brother TWAIN driver is chosen as the primary source. In PaperPort™ 12SE, click File, Scan or Get Photo and choose the Brother TWAIN driver.
OCR does not work.	<p>Try increasing the scanning resolution.</p> <p>(Macintosh users) Make sure you have downloaded and installed Presto! PageManager from http://nj.newsoft.com.tw/download/brother/PM9SEInstaller_BR_multilang.dmg</p>
Network scanning does not work.	See <i>Network difficulties (Network models only)</i> on page 89.
Cannot scan.	<p>(For MFC-7860DW)</p> <p>Contact your administrator to check your Secure Function Lock Settings.</p>

Software difficulties

Difficulties	Suggestions
Cannot install software or print.	<p>(Windows® only)</p> <p>Run the Repair MFL-Pro Suite program on the installation CD-ROM. This program will repair and reinstall the software.</p>
Cannot perform '2 in 1' or '4 in 1' printing.	Check that the paper size setting in the application and in the printer driver are the same.

B

Software difficulties (continued)

Difficulties	Suggestions
The machine does not print from Adobe® Illustrator®.	Try to reduce the print resolution. (See <i>Basic tab</i> in the <i>Software User's Guide</i> .)

Paper handling difficulties

Difficulties	Suggestions
The machine does not feed paper. The LCD shows No Paper or a Paper Jam message.	<ul style="list-style-type: none"> ■ If there is no paper, load a new stack of paper into the paper tray. ■ If there is paper in the paper tray, make sure it is straight. If the paper is curled, you should straighten it. Sometimes it is helpful to remove the paper, turn the stack over and put it back into the paper tray. ■ Reduce the amount of paper in the paper tray, and then try again. ■ Make sure that manual feed mode is not chosen in the printer driver. ■ Clean the paper pick-up roller. See <i>Cleaning the paper pick-up rollers</i> in <i>Appendix A</i> of the <i>Advanced User's Guide</i>. ■ If the LCD shows the Paper Jam message and you still have a problem, see <i>Error and maintenance messages</i> on page 64.
How do I print on envelopes?	You can load envelopes from the manual feed slot. Your application must be set up to print the envelope size you are using. This is usually done in the Page Setup or Document Setup menu of your application.
What paper can I use?	<p>You can use thin paper, plain paper, bond paper, recycled paper, envelopes and labels that are made for laser machines. (For details, see <i>Acceptable paper and other print media</i> on page 17.)</p> <p>You can load envelopes from the manual feed slot.</p>
There is a paper jam.	Clear the jammed paper. (See <i>Paper Jams</i> on page 72.)

Print quality difficulties

Difficulties	Suggestions
Printed pages are curled.	<ul style="list-style-type: none"> ■ Low quality thin or thick paper or not printing on the recommended side of the paper could cause this problem. Try turning over the stack of paper in the paper tray. ■ Make sure that you choose the Paper Type that suits the print media type you are using. (See <i>Acceptable paper and other print media</i> on page 17.)
Printed pages are smeared.	The Paper Type setting may be incorrect for the type of print media you are using, or the print media may be too thick or have a rough surface. (See <i>Acceptable paper and other print media</i> on page 17 and <i>Basic tab</i> in the <i>Software User's Guide</i> .)
Printouts are too light.	<ul style="list-style-type: none"> ■ If this problem occurs when making copies or printing received faxes, turn Toner Save mode to Off in the machine menu settings. (See <i>Toner Save</i> in <i>Chapter 1</i> of the <i>Advanced User's Guide</i>.) ■ Set Toner Save mode to Off in the Advanced tab in the printer driver. (See <i>Advanced tab</i> in the <i>Software User's Guide</i>.)

Network difficulties (Network models only)

Difficulties	Suggestions
Cannot print over a wired network.	<p>If you are having network problems see the <i>Network User's Guide</i> for more information.</p> <p>Make sure your machine is powered on and is on-line and in Ready mode. Print the Network Configuration list to see your current network settings. (See <i>Reports in Chapter 6</i> of the <i>Advanced User's Guide</i>.) Reconnect the LAN cable to the hub to verify that the cable and network connections are good. If possible, try connecting the machine to a different port on your hub using a different cable. You can check the current wired network status from the Network control panel menu.</p>
The network scanning feature does not work.	<p>(Windows®)</p> <p>It is necessary to set the third-party Security/Firewall Software to allow Network scanning. To add port 54925 for Network scanning, enter the information below:</p> <ul style="list-style-type: none"> ■ In Name: Enter any description, for example Brother NetScan. ■ In Port number: Enter 54925. ■ In Protocol: UDP is selected. <p>Please refer to the instruction manual that came with your third-party Security/Firewall Software or contact the software manufacturer.</p> <p>For more details, you can read FAQs and troubleshooting suggestions at http://solutions.brother.com/.</p> <p>(Macintosh)</p> <ul style="list-style-type: none"> ■ The network scanning feature may not work due to the firewall settings. Change or disable the firewall settings. If you are using a third-party personal Firewall software, see the User's Guide for your software or contact the software manufacturer. ■ Re-select your machine in the Device Selector application located in Macintosh HD/Library/Printers/Brother/Utilities/Device Selector or from the model list in ControlCenter2.
The network PC-Fax Receive feature does not work.	<p>(Windows® only)</p> <p>It is necessary to set the third-party Security/Firewall Software to allow PC-FAX Rx. To add port 54926 for Network PC-FAX Rx, enter the information below:</p> <ul style="list-style-type: none"> ■ In Name: Enter any description, for example Brother PC-FAX Rx. ■ In Port number: Enter 54926. ■ In Protocol: UDP is selected. <p>Please refer to the instruction manual that came with your third-party Security/Firewall Software or contact the software manufacturer.</p> <p>For more details, you can read FAQs and troubleshooting suggestions at http://solutions.brother.com/.</p>



Network difficulties (Network models only) (continued)

Difficulties	Suggestions
Your computer cannot find your machine.	<p>(Windows®) The firewall setting on your PC may be rejecting the necessary network connection. (For details, see the instructions above.)</p> <p>(Macintosh)</p> <ul style="list-style-type: none">■ The computer may be unable to detect the machine due to the firewall settings. Change or disable the firewall settings. If you are using a third-party personal Firewall software, see the User's Guide for your software or contact the software manufacturer.■ Re-select your machine in the Device Selector application located in Macintosh HD/Library/Printers/Brother/Utilities/Device Selector or from the model list in ControlCenter2.
Cannot connect to wireless network. (MFC-7860DW)	Investigate the problem using the WLAN Report . Press Menu , 5 , 7 , and then press Start . For more details, see the <i>Quick Setup Guide</i> .

Other

Difficulties	Suggestions
The machine will not turn on.	<p>Adverse conditions on the power connection (such as lightning or a power surge) may have triggered the machine's internal safety mechanisms. Turn the machine off and unplug the power cord. Wait for ten minutes, then plug in the power cord and turn the machine on.</p> <p>If the problem is not solved, turn off the machine. Plug the power cord into a different known working outlet and turn on the machine.</p>

Setting Dial Tone detection

Setting the Dial Tone to `Detection` will shorten the Dial Tone detect pause.

- 1 (USA) Press **Menu, 0, 4**.
(Canada) Press **Menu, 0, 5**.

```
Initial Setup
4.Dial Tone
```

- 2 Press **▲** or **▼** to choose `Detection` or `No Detection`. Press **OK**.
- 3 Press **Stop/Exit**.

Telephone line interference

If you are having difficulty sending or receiving a fax due to possible interference on the telephone line, we recommend that you adjust the Equalization for compatibility to reduce the modem speed for fax operations.

- 1 Press **Menu, 2, 0, 1**.

```
Miscellaneous
1.Compatibility
```

- 2 Press **▲** or **▼** to choose `Basic (for VoIP)`, `Normal` or `High (MFC-7860DW)`.

- `Basic (for VoIP)` reduces the modem speed to 9600 bps and turns the error correction mode (ECM) off.

For a standard telephone line: If you regularly experience interference on your standard telephone line try this setting.

If you are using VoIP: VoIP service providers offer fax support using various standards. If you regularly experience fax transmission errors try this setting.

- `Normal` sets the modem speed at 14400 bps.
- `High` sets the modem speed at 33600 bps (MFC-7860DW only).

Press **OK**.

- 3 Press **Stop/Exit**.



Note

When you change the Compatibility to `Basic (for VoIP)`, the ECM feature is only available for fax sending.

Improving the print quality

If you have a print quality problem, print a test page first (**Menu, 4, 2, 3**). If the printout looks good, the problem is probably not the machine. Check the interface cable connections or try printing a different document. If the printout or test page printed from the machine has a quality problem, check the following steps first. And then, if you still have a print quality problem, check the chart below and follow the recommendations.







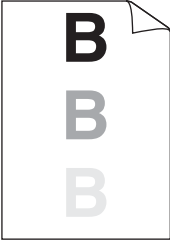

Note

Using non-Brother supplies may affect the print quality, hardware performance, and machine reliability.



- 1 To get the best print quality, we suggest using the recommended paper. Check that you use paper that meets our specifications. (See *Acceptable paper and other print media* on page 17.)
- 2 Check that the drum unit and toner cartridges are installed properly.

Examples of poor print quality	Recommendation
 <p style="text-align: center;">Faint</p>	<ul style="list-style-type: none"> ■ Take out the drum unit and toner cartridge assembly. Hold the assembly level with both hands and gently shake it from side to side several times to spread the toner evenly inside the cartridge. ■ Check if the Toner Settings of Replace Toner is Continue (Continue mode) by pressing Menu, 1, 8. (See <i>Toner settings</i> in <i>Chapter 1</i> of the <i>Advanced User's Guide</i>.) ■ Check the machine's environment. Conditions such as humidity, high temperatures, and so on, may cause this print fault. (See <i>Safety and Legal booklet</i>.) ■ If the whole page is too light, Toner Save mode may be on. Turn off Toner Save mode in the machine menu settings or Toner Save mode in the printer Properties of the driver. (See <i>Toner save</i> in <i>Chapter 1</i> of the <i>Advanced User's Guide</i> or <i>Advanced tab</i> in the <i>Software User's Guide</i>.) ■ Clean the corona wire of the drum unit. (See <i>Cleaning the corona wire</i> on page 58.) ■ Put in a new toner cartridge. (See <i>Replacing the toner cartridge</i> on page 53.) ■ Put in a new drum unit. (See <i>Replacing the drum unit</i> on page 59.)

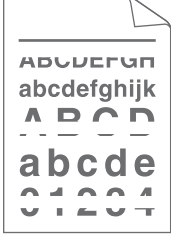
Examples of poor print quality	Recommendation
 <p data-bbox="230 562 426 587">Gray background</p>	<ul style="list-style-type: none"> ■ Make sure that you use paper that meets our specifications. (See <i>Acceptable paper and other print media</i> on page 17.) ■ Check the machine's environment. Conditions such as high temperatures and high humidity can increase the amount of background shading. (See <i>Safety and Legal booklet</i>.) ■ Put in a new toner cartridge. (See <i>Replacing the toner cartridge</i> on page 53.) ■ Put in a new drum unit. (See <i>Replacing the drum unit</i> on page 59.)
 <p data-bbox="293 896 363 921">Ghost</p>	<ul style="list-style-type: none"> ■ Make sure that you use paper that meets our specifications. Rough-surfaced paper or thick print media may cause this problem. (See <i>Acceptable paper and other print media</i> on page 17.) ■ Make sure that you choose the proper media type in the printer driver or in the machine's Paper Type menu setting. (See <i>Acceptable paper and other print media</i> on page 17 and <i>Basic tab</i> in the <i>Software User's Guide</i>.) ■ Choose Reduce Ghosting mode in the printer driver. (See <i>Ghost Reduction Setting</i> in the <i>Software User's Guide</i>.) ■ Put in a new toner cartridge. (See <i>Replacing the toner cartridge</i> on page 53.) ■ Put in a new drum unit. (See <i>Replacing the drum unit</i> on page 59.) ■ The fuser unit may be contaminated. Call Brother Customer Service.
 <p data-bbox="252 1410 410 1435">Toner specks</p>	<ul style="list-style-type: none"> ■ Make sure that you use paper that meets our specifications. Rough-surfaced paper may cause the problem. (See <i>Acceptable paper and other print media</i> on page 17.) ■ Clean the corona wire and the drum unit. (See <i>Cleaning the corona wire</i> on page 58 and <i>Cleaning the drum unit</i> in <i>Appendix A</i> of the <i>Advanced User's Guide</i>.) ■ The drum unit may be damaged. Put in a new drum unit. (See <i>Replacing the drum unit</i> on page 59.) ■ The fuser unit may be contaminated. Call Brother Customer Service.
 <p data-bbox="259 1752 403 1777">Hollow print</p>	<ul style="list-style-type: none"> ■ Make sure that you use paper that meets our specifications. (See <i>Acceptable paper and other print media</i> on page 17.) ■ Choose Thick Paper mode in the printer driver, choose Thick in the machine's Paper Type menu setting or use thinner paper than you are currently using. (See <i>Paper Type</i> on page 17 and <i>Basic tab</i> in the <i>Software User's Guide</i>.) ■ Check the machine's environment. Conditions such as high humidity can cause hollow print. (See <i>Safety and Legal booklet</i>.) ■ The drum unit may be damaged. Put in a new drum unit. (See <i>Replacing the drum unit</i> on page 59.)

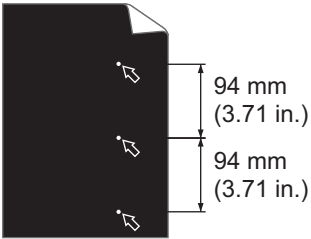
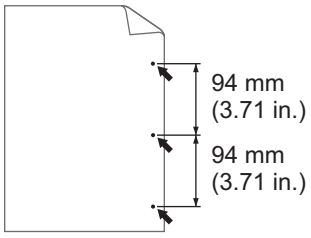
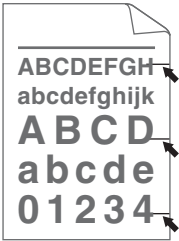
Examples of poor print quality	Recommendation
 <p data-bbox="248 562 345 585">All black</p>	<ul style="list-style-type: none"> <li data-bbox="514 264 1227 349">■ Clean the corona wire inside the drum unit by sliding the green tab. Be sure to return the green tab to the home position (▲). (See <i>Cleaning the corona wire</i> on page 58.) <li data-bbox="514 365 1227 421">■ The drum unit may be damaged. Put in a new drum unit. (See <i>Replacing the drum unit</i> on page 59.) <li data-bbox="514 436 1227 492">■ The fuser unit may be contaminated. Call Brother Customer Service.
 <p data-bbox="138 900 456 923">White lines across the page</p>	<ul style="list-style-type: none"> <li data-bbox="514 602 1227 658">■ Make sure that you use paper that meets our specifications. A rough surfaced paper or thick print media can cause problems. <li data-bbox="514 674 1227 788">■ Make sure that you choose the appropriate media type in the printer driver or in the machine's Paper Type menu setting. (See <i>Acceptable paper and other print media</i> on page 17 and <i>Basic tab</i> in the <i>Software User's Guide</i>.) <li data-bbox="514 803 1227 888">■ The problem may disappear by itself. Print multiple pages to clear this problem, especially if the machine has not been used for a long time. <li data-bbox="514 904 1227 960">■ The drum unit may be damaged. Put in a new drum unit. (See <i>Replacing the drum unit</i> on page 59.)
 <p data-bbox="171 1273 423 1296">Lines across the page</p>	<ul style="list-style-type: none"> <li data-bbox="514 975 1227 1031">■ Clean the corona wire of the drum unit. (See <i>Cleaning the corona wire</i> on page 58.) <li data-bbox="514 1047 1227 1103">■ The drum unit may be damaged. Put in a new drum unit. (See <i>Replacing the drum unit</i> on page 59.)
 <p data-bbox="134 1607 466 1657">White lines, bands or ribbing across the page</p>	<ul style="list-style-type: none"> <li data-bbox="514 1309 1227 1394">■ Check the machine's environment. Conditions such as high humidity and high temperatures may cause this print quality problem. <li data-bbox="514 1410 1227 1466">■ If the problem is not solved after printing a few pages, put in a new drum unit. (See <i>Replacing the drum unit</i> on page 59.)

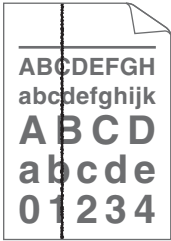
Examples of poor print quality	Recommendation
 <p data-bbox="168 558 488 641">White Spots on black text and graphics at 94 mm (3.71 in.) intervals</p>  <p data-bbox="159 942 499 1000">Black Spots at 94 mm (3.71 in.) intervals</p>	<ul style="list-style-type: none"> <li data-bbox="543 266 1252 407">■ Make ten copies of a blank, white sheet of paper. (See <i>How to copy</i> on page 48.) If the problem is not solved, the drum unit may have glue from a label stuck on the OPC drum surface. Clean the drum unit. (See <i>Cleaning the drum unit</i> in <i>Appendix A</i> of the <i>Advanced User's Guide</i>.) <li data-bbox="543 426 1226 479">■ The drum unit may be damaged. Put in a new drum unit. (See <i>Replacing the drum unit</i> on page 59.)
 <p data-bbox="159 1307 496 1365">Black toner marks across the page</p>	<ul style="list-style-type: none"> <li data-bbox="543 1016 1252 1128">■ If you use label sheets for laser printers, the glue from the sheets may sometimes stick to the OPC drum surface. Clean the drum unit. (See <i>Cleaning the drum unit</i> in <i>Appendix A</i> of the <i>Advanced User's Guide</i>.) <li data-bbox="543 1147 1252 1199">■ Make sure that you use paper that meets our specifications. (See <i>Acceptable paper and other print media</i> on page 17.) <li data-bbox="543 1219 1199 1271">■ Do not use paper that has clips or staples because they will scratch the surface of the drum. <li data-bbox="543 1290 1252 1342">■ If the unpacked drum unit is in direct sunlight or room light, the unit may be damaged. <li data-bbox="543 1362 1184 1414">■ The toner cartridge may be damaged. Put in a new toner cartridge. (See <i>Replacing the toner cartridge</i> on page 53.) <li data-bbox="543 1433 1226 1485">■ The drum unit may be damaged. Put in a new drum unit. (See <i>Replacing the drum unit</i> on page 59.)

Examples of poor print quality	Recommendation
 <p>Black lines down the page Printed pages have toner stains down the page.</p>	<ul style="list-style-type: none"> ■ Clean the corona wire inside the drum unit by sliding the green tab. (See <i>Cleaning the corona wire</i> on page 58.) ■ Make sure the green tab of the corona wire is at the home position (▲). ■ The drum unit may be damaged. Put in a new drum unit. (See <i>Replacing the drum unit</i> on page 59.) ■ The toner cartridge may be damaged. Put in a new toner cartridge. (See <i>Replacing the toner cartridge</i> on page 53.) ■ The fuser unit may be contaminated. Call Brother Customer Service.
 <p>White lines down the page</p>	<ul style="list-style-type: none"> ■ The toner cartridge may be damaged. Put in a new toner cartridge. (See <i>Replacing the toner cartridge</i> on page 53.) ■ The drum unit may be damaged. Put in a new drum unit. (See <i>Replacing the drum unit</i> on page 59.) ■ Check if the Toner Settings of <i>Replace Toner is Continue</i> (Continue mode), by pressing Menu, 1, 8. (See <i>Toner settings</i> in Chapter 1 of the <i>Advanced User's Guide</i>.) ■ Make sure that a torn piece of paper is not stuck inside the machine blocking the scanner.
 <p>Page skewed</p>	<ul style="list-style-type: none"> ■ Make sure that the paper or other print media is loaded properly in the paper tray and that the guides are not too tight or too loose against the paper stack. ■ Set the paper guides correctly. (See <i>Loading paper</i> on page 9.) ■ If you are using the manual feed slot, see <i>Loading paper in the manual feed slot</i> on page 11. ■ The paper tray may be too full. (See <i>Loading paper</i> on page 9.) ■ Check the paper type and quality. (See <i>Acceptable paper and other print media</i> on page 17.) ■ Check for loose objects such as torn paper inside the machine. ■ Verify that the two green envelope levers inside the back cover are set to the same position. ■ Verify that the two gray Anti-Curl Levers inside the back cover are set to the same position. ■ If the problem only occurs during duplex printing, check for torn paper in the duplex tray, verify that the duplex tray is inserted completely and verify that the back cover is closed completely.

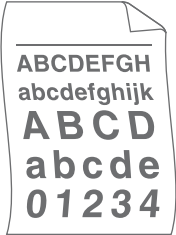
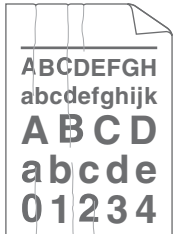
Examples of poor print quality	Recommendation
 <p data-bbox="241 556 415 585">Curled or wavy</p>	<ul style="list-style-type: none"> <li data-bbox="543 266 1256 353">■ Check the paper type and quality. High temperatures and high humidity will cause paper to curl. (See <i>Acceptable paper and other print media</i> on page 17.) <li data-bbox="543 369 1256 484">■ If you do not use the machine often, the paper may have been in the paper tray too long. Turn over the stack of paper in the paper tray. Also, fan the paper stack and then rotate the paper 180° in the paper tray. <li data-bbox="543 498 1256 556">■ Open the back cover (face-up output tray) for the machine to eject printed pages onto the face-up output tray. <li data-bbox="543 569 1256 685">■ Choose Reduce Paper Curl mode in the printer driver when you do not use our recommended paper. (See <i>Other Print Options</i> (for Windows®) or <i>Print Settings</i> (For Macintosh) in the <i>Software User's Guide</i>.)
 <p data-bbox="214 991 443 1020">Wrinkles or creases</p>	<ul style="list-style-type: none"> <li data-bbox="543 701 1256 759">■ Make sure that the paper is loaded properly. (See <i>Loading paper</i> on page 9.) <li data-bbox="543 772 1256 830">■ Check the paper type and quality. (See <i>Acceptable paper and other print media</i> on page 17.) <li data-bbox="543 844 1256 902">■ Turn over the stack of paper in the tray or try rotating the paper 180° in the input tray.

Examples of poor print quality



Envelope creases

Recommendation

- Make sure that the two green envelope levers inside the back cover are pulled down when you print the envelope.

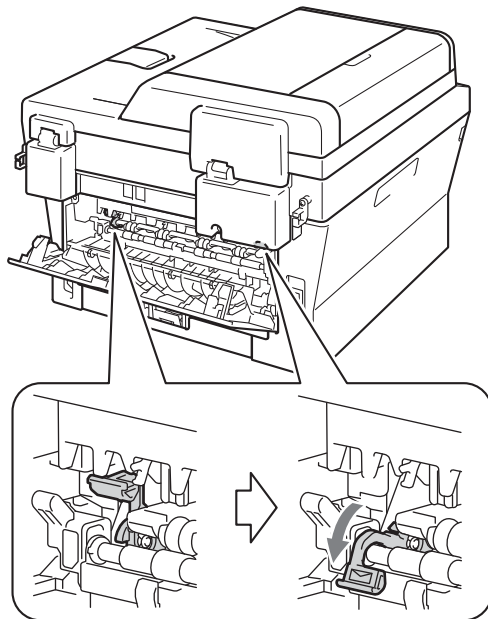

 **Note**

When you have finished printing, open the back cover and reset the two green levers back to their original position.

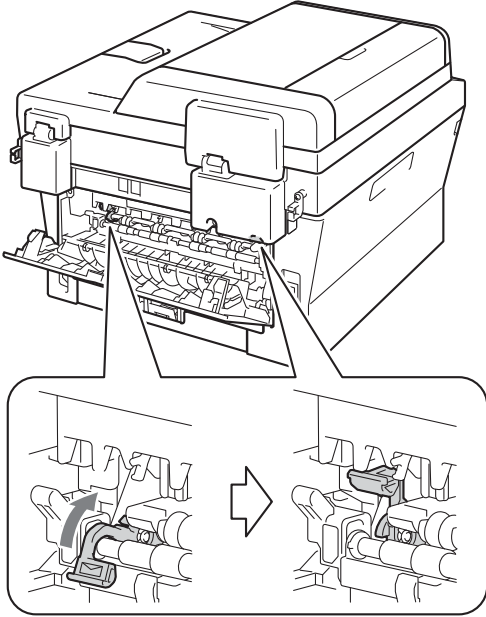
Examples of poor print quality	Recommendation
 <p data-bbox="264 558 392 587">Poor fixing</p>	<ul style="list-style-type: none"> <li data-bbox="543 266 1249 324">■ Open the back cover and make sure that the two green envelope levers on the left and right hand sides are in the up position.  <ul style="list-style-type: none"> <li data-bbox="543 1020 1243 1166">■ Choose Improve Toner Fixing mode in the printer driver. (See <i>Other Print Options</i> (for Windows®) or <i>Print Settings</i> (For Macintosh) in the <i>Software User's Guide</i>.) If this selection does not provide enough improvement, select Thicker Paper in Media Type settings.

Examples of poor print quality



Curled

Recommendation

■ Choose **Reduce Paper Curl** mode in the printer driver when you do not use our recommended paper. (See *Other Print Options* (for Windows®) or *Print Settings* (For Macintosh) in the *Software User's Guide*.)

■ Turn the paper over in the paper tray, and print again. (Excluding letterhead paper) If the problems remains, switch the Anti-Curl Levers as follows:

- 1 Open the back cover.
- 2 Lift the lever (1) and slide the two gray levers (2) in the direction of the arrow.

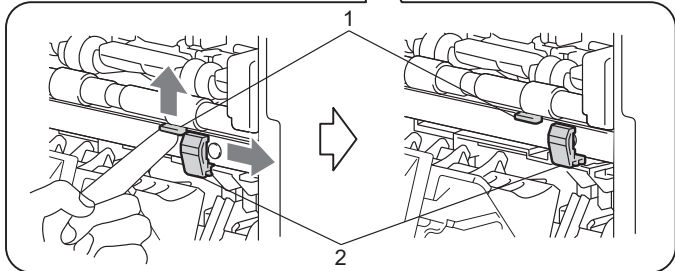
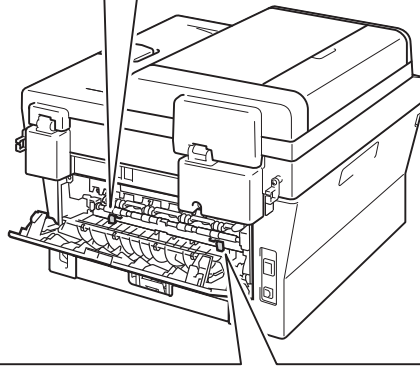
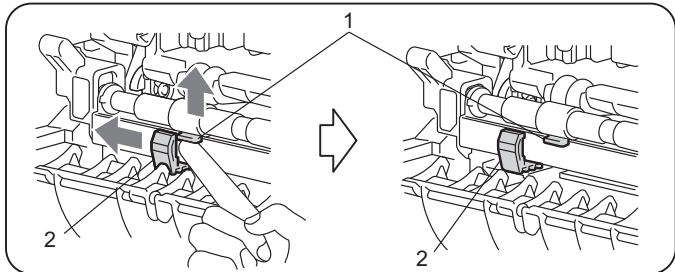

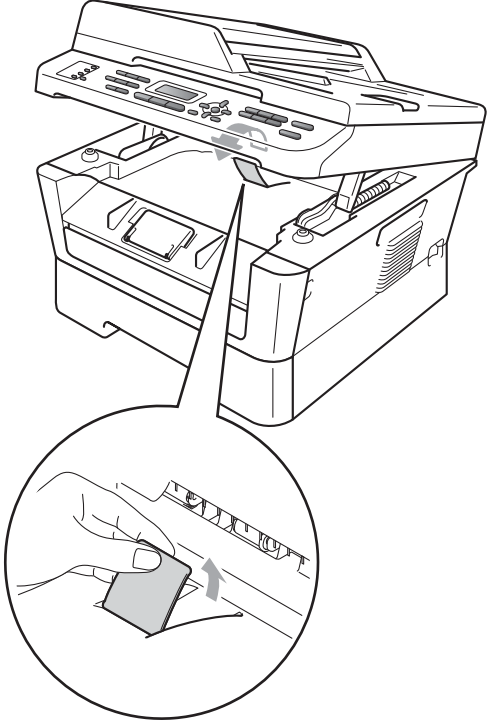
Examples of poor print quality	Recommendation
 <p data-bbox="289 568 369 595">Curled</p>	<ul style="list-style-type: none"> <li data-bbox="546 266 934 293">■ Lift up the output tray support flap. 

Machine Information

Checking the Serial Number

You can see the machine's Serial Number on the LCD.

- 1 For MFC-7360N and MFC-7460DN, press **Menu, 6, 1**.
For MFC-7860DW, press **Menu, 7, 1**.

```
Machine Info.  
1.Serial No.
```

- 2 The machine will display the machine's Serial Number on the LCD.
- 3 Press **Stop/Exit**.

Reset functions

The following reset functions are available:

1 Network

You can reset the internal print server back to its default factory settings such as the password and IP address information.

2 Address & Fax

Address & Fax resets the following settings:

- Address Book
(One Touch Dial/Speed Dial/Setup Groups)
- Programmed fax jobs in the memory
(Polled TX, Delayed Fax)
- Station ID
(name and number)
- Coverpage Msg
(comments)
- Remote Fax Options
(Remote Access Code, Fax Storage, Fax Forwarding, Paging and PC-Fax)
- Report settings
(Transmission Verification Report/
Tel Index List/Fax Journal)
- Setting Lock password

3 All Settings

You can reset all the machine settings back to the settings that were set at the factory.

Brother strongly recommends you perform this operation when you dispose of the machine.



Note

Unplug the interface cable before you choose **Network** or **All Settings**.

How to reset the machine

- 1 Press **Menu, 0**.
- 2 Press **▲** or **▼** to display `Reset`.
Press **OK**.
- 3 Press **▲** or **▼** to choose the reset function you want to use.
Press **OK**.
- 4 Do one of the following:
 - To reset the settings, press **1** and go to step 5.
 - To exit without making changes, press **2** and go to step 6.
- 5 You will be asked to reset the machine. Do one of the following:
 - To reset the machine press **1**. The machine will begin the reset.
 - To exit without resetting the machine, press **2**. Go to step 6.
- 6 Press **Stop/Exit**.



Note

You can also reset the Network settings.

- For MFC-7360N and MFC-7460DN, press **Menu, 5, 0**.
- For MFC-7860DW, press **Menu, 6, 0**.

On-screen programming

Your machine has been designed to be easy to use. The LCD provides on-screen programming using the menu keys.

We have created step by step on-screen instructions to help you program your machine. Simply follow the steps as they guide you through the menu selections and programming options.

Menu table

You can program your machine by using the *Menu table* on page 105. These pages list the menu selections and options. Press **Menu** followed by the menu numbers to program your machine. For example, to set *Beeper* volume to *Low*:

- 1 Press **Menu**, **1**, **3**, **2**.
- 2 Press **▲** or **▼** to choose *Low*.
- 3 Press **OK**.

How to access the menu mode

- 1 Press **Menu**.
- 2 Choose an option.
 - Press **1** for General Setup menu.
 - Press **2** for Fax menu.
 - Press **3** for Copy menu.

(MFC-7860DW)

- Press **4** for Printer menu.
- Press **5** for Print Reports menu.
- Press **6** for Network menu.
- Press **7** for Machine Info. menu.

(MFC-7360N and MFC-7460DN)

- Press **4** for Print Reports menu.
- Press **5** for Network menu.
- Press **6** for Machine Info. menu.
- Press **9** for Service menu.¹
- Press **0** for Initial Setup menu.

¹ This will appear only when the LCD shows an error message.

You can also scroll through each menu level by pressing **▲** or **▼** for the direction you want.

- 3 Press **OK** when the option you want appears on the LCD. The LCD will then show the next menu level.
- 4 Press **▲** or **▼** to scroll to your next menu selection.
- 5 Press **OK**. When you have finished setting an option, the LCD will show *Accepted*.
- 6 Press **Stop/Exit** to exit Menu mode.

Menu table

The factory settings are shown in Bold with an asterisk.

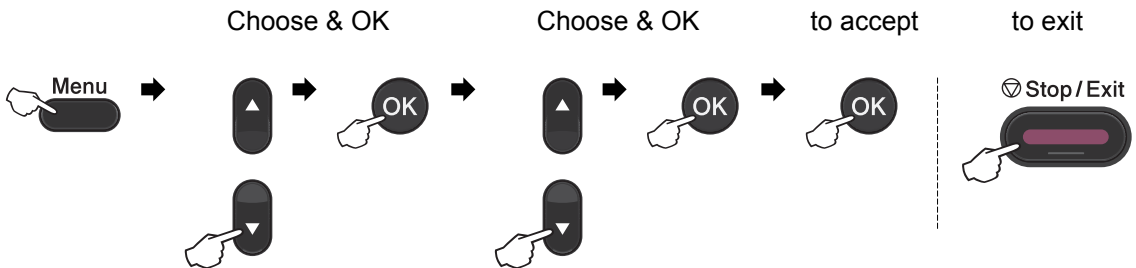

Level 1	Level 2	Level 3	Level 4	Options	Descriptions	Page
1. General Setup	1. Mode Timer	—	—	0 Sec 30 Secs 1 Min 2 Mins* 5 Mins Off	Sets the time to return to Fax mode and the time the machine will change from individual user to Public user mode when using Secure Function Lock.	See ¹ .
		1. Paper Type	—	Thin Plain* Thick Thicker Recycled Paper Label	Sets the type of paper in the paper tray.	17
	2. Paper Size		—	A4 Letter* Legal Executive A5 A5 L A6 B5 B6 Folio	Sets the size of the paper in the paper tray.	17

¹ See *Advanced User's Guide*.

² See *Software User's Guide*



The factory settings are shown in Bold with an asterisk.

Level 1	Level 2	Level 3	Level 4	Options	Descriptions	Page
1. General Setup (Continued)	3. Volume	1. Ring	—	Off Low Med* High	Adjusts the ring volume.	See ¹ .
		2. Beeper	—	Off Low Med* High	Adjusts the volume level of the beeper.	
		3. Speaker	—	Off Low Med* High	Adjusts the speaker volume.	
	4. Ecology	1. Toner Save	—	On Off*	Increases the page yield of the toner cartridge.	
		2. Sleep Time	—	Range varies depending on models. 003Min*	Conserves power.	
	5. LCD Contrast	—	—	-□□□■+ -□□□■+ -□■□□+* -□■□□+ -■□□□+	Adjusts the contrast of the LCD.	
	6. Security	1. TX Lock (MFC-7360N and MFC-7460DN)	—	—	Prohibits most operations except receiving faxes.	

¹ See *Advanced User's Guide*.

² See *Software User's Guide*



The factory settings are shown in Bold with an asterisk.

Level 1	Level 2	Level 3	Level 4	Options	Descriptions	Page	
1. General Setup (Continued)	6. Security (Continued)	1. Function Lock (MFC-7860DW)	—	—	Can restrict selected machine operation for up to 25 individual users and all other non-authorized Public users.	See ¹ .	
		2. Setting Lock	—	—	Stops unauthorized users from changing the machine's current settings.		
	7. Glass ScanSize (MFC-7360N)	—	—	Letter* A4	Adjusts the scan area of the scanner glass to the size of the document.	26	
	7. Document Scan (MFC-7460DN and MFC-7860DW)	1. Glass ScanSize	—	—	Letter* A4	Adjusts the scan area of the scanner glass to the size of the document.	26
		2. File Size	1. Color	—	Small Middle* Large	You can set your own default settings of the data compression rate.	See ² .
2. Gray	—		Small Middle* Large				
8. Replace Toner	—	—	—	Continue Stop*	The machine will stop printing until you replace the toner cartridge.	See ¹ .	
¹ See <i>Advanced User's Guide</i> . ² See <i>Software User's Guide</i>							
 The factory settings are shown in Bold with an asterisk.							

Level 1	Level 2	Level 3	Options	Descriptions	Page
2. Fax	1. Setup Receive (In Fax mode only)	1. Ring Delay	00 01 02 03 04*	Sets the number of rings before the machine answers in Fax Only or Fax/Tel mode.	30
¹ See <i>Advanced User's Guide</i> .					
 The factory settings are shown in Bold with an asterisk.					

Level 1	Level 2	Level 3	Options	Descriptions	Page
2. Fax (Continued)	1. Setup Receive (In Fax mode only) (Continued)	2. F/T Ring Time	20 Secs* 30 Secs 40 Secs 70 Secs	Sets the pseudo/double-ring time in Fax/Tel mode.	30
		3. Easy Receive	On* Off	Receives fax messages without pressing Start .	31
		4. Remote Codes	On* (*51, #51) Off	Allows you to answer all calls at extension telephones and use codes to turn the machine on or off. You can personalize these codes.	38
		5. Auto Reduction	On* Off	Reduces the size of incoming faxes.	See ¹ .
		6. Print Density	-□□□■+ -□□□■+ -□□■□+* -□■□□+ -■□□□+	Makes printouts darker or lighter.	
		7. Polling RX	—	Sets up your machine to poll another fax machine.	
		8. Fax Rx Stamp	On Off*	Prints the received time and date on the top of the received faxes.	
		9. Duplex (MFC-7460DN and MFC-7860DW)	On Off*	Prints receive faxes on both sides of the paper.	
		2. Setup Send (In Fax mode only)	1. Contrast	Auto* Light Dark	Changes the lightness or darkness of faxes you send.
	2. Fax Resolution		Standard* Fine S. Fine Photo	Sets the default resolution for outgoing faxes.	
	3. Delayed Fax		Set Time=00:00	Sets the time of day in 24 hour format that the delayed faxes will be sent.	

¹ See *Advanced User's Guide*.



The factory settings are shown in Bold with an asterisk.

Level 1	Level 2	Level 3	Options	Descriptions	Page	
2. Fax (Continued)	2. Setup Send (In Fax mode only) (Continued)	4. Batch TX	On Off*	Combines delayed faxes going to the same fax number at the same time of day into one transmission.	See ¹ .	
		5. Real Time TX	Next Fax:On Next Fax:Off On Off*	Sends a fax without using the memory.		
		6. Polled TX	On Off*	Sets up your machine with a document to be retrieved by another fax machine.		
		7. Coverpg Setup	Next Fax:On Next Fax:Off On Off* Print Sample	Automatically sends a cover page you have programmed.		
		8. Coveragepage Msg	—	Sets up your own comments for the fax cover page.		
		9. Overseas Mode	On Off*	If you are having difficulty sending faxes overseas, set this to On.		
	3. Address Book	1. One Touch Dial	1. One Touch Dial	—	Stores up to 8 One Touch Dial numbers, so you can dial by pressing one key (and Start .)	42
			2. Speed Dial	—	Stores up to 200 Speed Dial numbers, so you can dial by pressing only a few keys (and Start .)	44
			3. Setup Groups	—	Sets up to 8 Group numbers for Broadcasting.	See ¹ .
	4. Report Setting	1. Transmission	On On+Image Off* Off+Image	Sets initial setup for Transmission Verification Report.	26	
	¹ See <i>Advanced User's Guide</i> .					
	 The factory settings are shown in Bold with an asterisk.					

Level 1	Level 2	Level 3	Options	Descriptions	Page	
2. Fax (Continued)	4. Report Setting (Continued)	2. Journal Period	Off	Sets the interval for automatic printing of the Fax Journal.	See ¹ .	
			Every 50 Faxes*			
	Every 6 Hours					
	Every 12 Hours					
	Every 24 Hours					
	Every 2 Days					
	Every 7 Days					
	5. Remote Fax Opt	1. Fwd/Page/Store (Backup Print)	Off*	Fax Forward		Sets the machine to forward fax messages, to call your pager, to store incoming faxes in the memory (so you can retrieve them while you are away from your machine), or to send faxes to your PC. If you choose Fax Forward or PC-Fax Receive, you can turn on the safety feature Backup Print.
				Paging		
				Fax Storage		
		2. Remote Access	---*	Sets your own code for Remote Retrieval.		
		3. Print Fax	—	Prints incoming faxes stored in the memory.		
	6. Dial Restrict.	1. Dial Pad	Off*	Enter # twice		You can set the machine to restrict dialing when using the dial pad.
On						
2. One Touch Dial				Off*	You can set the machine to restrict the dialing of One Touch numbers.	
3. Speed Dial	Off*	You can set the machine to restrict the dialing of Speed Dial numbers.				
	7. Remaining Jobs	—	—	You can check which jobs are in the memory and lets you cancel scheduled jobs.		

¹ See *Advanced User's Guide*.



The factory settings are shown in Bold with an asterisk.

Level 1	Level 2	Level 3	Options	Descriptions	Page
2. Fax (Continued)	0. Miscellaneous	1. Compatibility	Normal* Basic (for VoIP) (MFC-7360N and MFC-7460DN) High* Normal Basic (for VoIP) (MFC-7860DW)	Adjusts the equalization for transmission difficulties. VoIP service providers offer fax support using various standards. If you regularly experience fax transmission errors, choose Basic (for VoIP).	91
		2. Distinctive	Off* Set	Uses the telephone company's Distinctive Ring subscriber service to register the ring pattern with the machine.	32
		3. Caller ID	Display# Print Report	View or print a list of the last 30 Caller IDs stored in the memory.	See ¹ .
¹ See <i>Advanced User's Guide</i> .					
 The factory settings are shown in Bold with an asterisk.					

Level 1	Level 2	Level 3	Options	Descriptions	Page
3. Copy	1. Quality	—	Auto* Text Photo Graph	You can choose the Copy resolution for your type of document.	See ¹ .
	2. Brightness	—	-□□□■+ -□□□■+ -□■□□+* -□■□□+ -■□□□+	Adjust the brightness for copies.	
	3. Contrast	—	-□□□■+ -□□□■+ -□■□□+* -□■□□+ -■□□□+	Adjusts the contrast for copies.	
¹ See <i>Advanced User's Guide</i> .					
 The factory settings are shown in Bold with an asterisk.					

Level 1	Level 2	Level 3	Options	Descriptions	Page
4. Printer (MFC-7860DW)	1. Emulation	—	Auto* HP LaserJet BR-Script 3	Chooses the emulation mode.	See ¹ .
	2. Print Options	1. Internal Font	1. HP LaserJet 2. BR-Script 3	Prints a list of the machine's internal fonts.	
		2. Configuration	—	Prints a list of the machine's printer settings.	
		3. Test Print	—	Prints a test page.	
	3. Duplex	—	Off* On (Long Edge) On (Short Edge)	Enables or disables duplex printing. You can also choose long edge or short edge duplex printing.	
4. Reset Printer	—	1. Reset 2. Exit	Restores the printer settings to the original factory default settings.		

¹ See *Software User's Guide*.



The factory settings are shown in Bold with an asterisk.

Level 1	Level 2	Level 3	Options	Descriptions	Page
4. Print Report (MFC-7360N and MFC-7460DN) 5. Print Report (MFC-7860DW)	1. Transmission	1. View on LCD	—	You can view the Transmission Verification Report for your last 200 outgoing faxes and print the last report.	See ¹ .
		2. Print Report	—		
	2. Help List	—	—	Prints the Help List so you can see at-a-glance how to quickly program your machine.	
	3. Tel Index List	1. Numeric	—	Lists names and numbers stored in the One Touch and Speed Dial memory, in numerical or alphabetical order.	
		2. Alphabetic	—		

¹ See *Advanced User's Guide*.

² See *Quick Setup Guide*.



The factory settings are shown in Bold with an asterisk.

Level 1	Level 2	Level 3	Options	Descriptions	Page		
4. Print Report (MFC-7360N and MFC-7460DN) 5. Print Report (MFC-7860DW) (Continued)	4. Fax Journal	—	—	Lists information about your last 200 incoming and outgoing faxes. (TX means Transmit. RX means Receive.)	See ¹ .		
		5. User Settings	—			—	Lists your settings.
		6. Network Config	—			—	Lists your Network settings.
	7. WLAN Report (MFC-7860DW)	—	—	Prints the result of wireless LAN connectivity diagnosis.	See ² .		
¹ See <i>Advanced User's Guide</i> .							
² See <i>Quick Setup Guide</i> .							
 The factory settings are shown in Bold with an asterisk.							

Level 1	Level 2	Level 3	Level 4	Options	Descriptions
5. Network (MFC-7360N and MFC-7460DN)	1. TCP/IP	1. Boot Method	—	Auto* Static RARP BOOTP DHCP	Chooses the Boot method that best suits your needs.
		2. IP Address	—	[000-255]. [000-255]. [000-255]. [000-255]	Enter the IP address.
		3. Subnet Mask	—	[000-255]. [000-255]. [000-255]. [000-255]	Enter the Subnet mask.
		4. Gateway	—	[000-255]. [000-255]. [000-255]. [000-255]	Enter the Gateway address.
		5. Node Name	—	BRNXXXXXXXXXXXXXX	Enter the Node name.
		6. WINS Config	—	Auto* Static	Chooses the WINS configuration mode.
See <i>Network User's Guide</i> .					
 The factory settings are shown in Bold with an asterisk.					



Level 1	Level 2	Level 3	Level 4	Options	Descriptions
5. Network (MFC-7360N and MFC-7460DN) (Continued)	1. TCP/IP (Continued)	7. WINS Server	—	Primary [000-255]. [000-255]. [000-255]. [000-255] Secondary [000-255]. [000-255]. [000-255]. [000-255]	Specifies the IP address of the primary or secondary WINS server.
		8. DNS Server	—	Primary [000-255]. [000-255]. [000-255]. [000-255] Secondary [000-255]. [000-255]. [000-255]. [000-255]	Specifies the IP address of the primary or secondary DNS server.
		9. APIPA	—	On* Off	Automatically allocates the IP address from the link-local address range.
		0. IPv6	—	On Off*	Enable or Disable the IPv6 protocol. If you want to use the IPv6 protocol, visit http://solutions. brother.com/ for more information.
	2. Ethernet	—	—	Auto* 100B-FD 100B-HD 10B-FD 10B-HD	Chooses the Ethernet link mode.
3. Status	—	—	Active 100B-FD Active 100B-HD Active 10B-FD Active 10B-HD Inactive Wired OFF	Shows the Ethernet link status.	
4. MAC Address	—	—	—	Shows the MAC address of the machine.	

See *Network User's Guide*.



The factory settings are shown in Bold with an asterisk.

Level 1	Level 2	Level 3	Level 4	Options	Descriptions
5. Network (MFC-7360N and MFC-7460DN) (Continued)	5. Scan To FTP (MFC-7460DN)	—	—	Color 100 dpi* Color 200 dpi Color 300 dpi Color 600 dpi Gray 100 dpi Gray 200 dpi Gray 300 dpi B&W 200 dpi B&W 200x100 dpi	Chooses the file format to send the scanned data via FTP.
	0. Network Reset	—	—	1. Reset 2. Exit	Restore all network settings to factory default.

See *Network User's Guide*.



The factory settings are shown in Bold with an asterisk.

Level 1	Level 2	Level 3	Level 4	Options	Descriptions
6. Network (MFC-7860DW)	1. Wired LAN	1. TCP/IP	1. Boot Method	Auto* Static RARP BOOTP DHCP	Chooses the Boot method that best suits your needs.
			2. IP Address	[000-255]. [000-255]. [000-255]. [000-255]	Enter the IP address.
			3. Subnet Mask	[000-255]. [000-255]. [000-255]. [000-255]	Enter the Subnet mask.
			4. Gateway	[000-255]. [000-255]. [000-255]. [000-255]	Enter the Gateway address.
			5. Node Name	BRNXXXXXXXXXXXXXX	Enter the Node name.
			6. WINS Config	Auto* Static	Chooses the WINS configuration mode.

See *Network User's Guide*.



The factory settings are shown in Bold with an asterisk.

Level 1	Level 2	Level 3	Level 4	Options	Descriptions		
6. Network (MFC-7860DW) (Continued)	1. Wired LAN (Continued)	1. TCP/IP (Continued)	7. WINS Server	Primary [000-255]. [000-255]. [000-255]. [000-255] Secondary [000-255]. [000-255]. [000-255]. [000-255]	Specifies the IP address of the primary or secondary WINS server.		
			8. DNS Server	Primary [000-255]. [000-255]. [000-255]. [000-255] Secondary [000-255]. [000-255]. [000-255]. [000-255]	Specifies the IP address of the primary or secondary DNS server.		
			9. APIPA	On* Off	Automatically allocates the IP address from the link-local address range.		
			0. IPv6	On Off*	Enable or Disable the IPv6 protocol. If you want to use the IPv6 protocol, visit http://solutions.brother.com/ for more information.		
		2. Ethernet	—	Auto* 100B-FD 100B-HD 10B-FD 10B-HD	Chooses the Ethernet link mode.		
		3. Wired Status	—	Active 100B-FD Active 100B-HD Active 10B-FD Active 10B-HD Inactive Wired OFF	You can see the current wired status.		
		4. MAC Address	—	—	Shows the MAC address of the machine.		
		5. Set to Default	—	1. Reset 2. Exit	Restore the wired network setting to factory default.		
		See Network User's Guide.					
		 The factory settings are shown in Bold with an asterisk.					

Level 1	Level 2	Level 3	Level 4	Options	Descriptions
6. Network (MFC-7860DW) (Continued)	1. Wired LAN (Continued)	6. Wired Enable	—	On* Off	Enable or Disable the Wired LAN manually.
			2. WLAN	1. TCP/IP	1. Boot Method
	2. IP Address	[000-255]. [000-255]. [000-255]. [000-255]			Enter the IP address.
	3. Subnet Mask	[000-255]. [000-255]. [000-255]. [000-255]			Enter the Subnet mask.
	4. Gateway	[000-255]. [000-255]. [000-255]. [000-255]			Enter the Gateway address.
	5. Node Name	BRWXXXXXXXXXXXXX			Enter the Node name.
	6. WINS Config	Auto* Static			Chooses the WINS configuration mode.
	7. WINS Server	Primary [000-255]. [000-255]. [000-255]. [000-255] Secondary [000-255]. [000-255]. [000-255]. [000-255]			Specifies the IP address of the primary or secondary WINS server.
	8. DNS Server	Primary [000-255]. [000-255]. [000-255]. [000-255] Secondary [000-255]. [000-255]. [000-255]. [000-255]			Specifies the IP address of the primary or secondary DNS server.
	9. APIPA	On* Off	Automatically allocates the IP address from the link-local address range.		
0. IPv6	On Off*	Enable or Disable the IPv6 protocol. If you want to use the IPv6 protocol, visit http://solutions. brother.com/ for more information.			
See <i>Network User's Guide</i> .					
 The factory settings are shown in Bold with an asterisk.					

Level 1	Level 2	Level 3	Level 4	Options	Descriptions
6. Network (MFC-7860DW) (Continued)	2. WLAN (Continued)	2. Setup Wizard	—	—	You can configure your print server.
		3. WPS/AOSS	—	—	You can easily configure your wireless network settings using the one-button push method.
		4. WPS w/PIN Code	—	—	You can easily configure your wireless network settings using WPS with a PIN code.
		5. WLAN Status	1. Status	Active (11b) Active (11g) Wired LAN Active WLAN OFF AOSS Active Connection Fail	You can see the current wireless network status.
			2. Signal	Strong Medium Weak None	You can see the current wireless network signal strength.
			3. SSID	—	You can see the current SSID.
			4. Comm. Mode	Ad-hoc Infrastructure	You can see the current Communication Mode.
		6. MAC Address	—	—	Shows the MAC address of the machine.
		7. Set to Default	—	1. Reset 2. Exit	Restore the wireless network settings to factory default.
		8. WLAN Enable	—	On Off*	Enable or disable the wireless LAN manually.

See *Network User's Guide*.



The factory settings are shown in Bold with an asterisk.

Level 1	Level 2	Level 3	Level 4	Options	Descriptions
6. Network (MFC-7860DW) (Continued)	3. Scan To FTP	—	—	Color 100 dpi* Color 200 dpi Color 300 dpi Color 600 dpi Gray 100 dpi Gray 200 dpi Gray 300 dpi B&W 200 dpi B&W 200x100 dpi	Chooses the file format to send the scanned data via FTP.
	0. Network Reset	—	—	1. Reset 2. Exit	Restores all network settings to factory default.
See <i>Network User's Guide</i> .					
 The factory settings are shown in Bold with an asterisk.					

Level 1	Level 2	Level 3	Options	Descriptions	Page
6. Machine Info. (MFC-7360N and MFC-7460DN)	1. Serial No.	—	—	You can check the serial number of your machine.	102
	7. Machine Info. (MFC-7860DW)	2. Page Counter	—	Total Fax/List Copy Print	You can check the number of total pages the machine has printed during its life.
	3. Drum Life	—	—	You can check the percentage of a Drum life that remains available.	
¹ See <i>Advanced User's Guide</i> .					
 The factory settings are shown in Bold with an asterisk.					

Level 1	Level 2	Level 3	Options	Descriptions	Page	
0. Initial Setup	1. Receive Mode	—	Fax Only* Fax/Tel External TAD Manual	Chooses the receive mode that best suits your needs.	27	
	2. Date&Time	1. Date&Time	—		Puts the date and time on the LCD and in headings of faxes you send.	See ² .
		2. Auto Daylight	On Off*		Changes for Daylight Savings Time automatically.	See ¹ .
		3. Time Zone (MFC-7460DN and MFC-7860DW)	UTC±XXX:XX		You can set the time zone for your country after you download IFAX.	See ³ .
	3. Station ID	—	Fax: Tel: Name:	Sets your name and fax number to appear on each page you fax.	See ² .	
	4. Tone/Pulse (in Canada)	—	Tone* Pulse	Chooses the dialing mode.		
	4. Dial Tone (in USA) 5. Dial Tone (in Canada)	—	Detection No Detection*	You can shorten the dial tone detect pause.	91	
	5. Dial Prefix (in USA) 6. Dial Prefix (in Canada)	—	—	Sets a prefix number that will always be added before the fax number every time you dial.	See ¹ .	
	6. Reset (in USA) 7. Reset (in Canada)	1. Network	1. Reset 2. Exit		Restores all network settings to factory default.	102
		2. Address & Fax	1. Reset 2. Exit		Restores all stored phone numbers and fax settings.	
3. All Settings		1. Reset 2. Exit		Restores all the machine settings to factory default.		
¹ See <i>Advanced User's Guide</i> . ² See <i>Quick Setup Guide</i> . ³ See <i>Network User's Guide</i> .						
 The factory settings are shown in Bold with an asterisk.						

Level 1	Level 2	Level 3	Options	Descriptions	Page
0.Initial Setup (Continued)	0.Local Language	—	(in USA) English* Español (in Canada) English* Français	Allows you to change the LCD language for your country.	See ² .
¹ See <i>Advanced User's Guide</i> . ² See <i>Quick Setup Guide</i> . ³ See <i>Network User's Guide</i> .					
 The factory settings are shown in Bold with an asterisk.					

Entering text

When setting certain menu selections, such as the Station ID, you will need to type text characters. The dial pad keys have letters printed on them. The keys: **0**, **#** and ***** do *not* have printed letters because they are used for special characters.

Press the appropriate dial pad key the number of times shown in this reference table to access the character you want.

Press Key	one time	two times	three times	four times	five times	six times	seven times	eight times	nine times
1	@	.	/	1	@	.	/	1	@
2	a	b	c	A	B	C	2	a	b
3	d	e	f	D	E	F	3	d	e
4	g	h	i	G	H	I	4	g	h
5	j	k	l	J	K	L	5	j	k
6	m	n	o	M	N	O	6	m	n
7	p	q	r	s	P	Q	R	S	7
8	t	u	v	T	U	V	8	t	u
9	w	x	y	z	W	X	Y	Z	9

For menu selections that do not allow lower case character selection, please use this reference table.

Press Key	one time	two times	three times	four times	five times
2	A	B	C	2	A
3	D	E	F	3	D
4	G	H	I	4	G
5	J	K	L	5	J
6	M	N	O	6	M
7	P	Q	R	7	P
8	T	U	V	8	T
9	W	X	Y	9	W

Inserting spaces

To enter a space in a fax number, press ► once between numbers. To enter a space in a name, press ► twice between characters.

Making corrections

If you entered a letter incorrectly and want to change it, press ◀ or ▶ to move the cursor to the incorrect character, and then press **Clear**.

Repeating letters

To enter a character on the same key as the previous character, press ► to move the cursor right before pressing the key again.

Special characters and symbols

Press *****, **#** or **0**, then press **◀** or **▶** to move the cursor to the symbol or character you want. Press **OK** to choose it. The symbols and characters below will appear depending on your menu selection.

Press *	for	(space) ! " # \$ % & ' () * + , - . / €
Press #	for	: ; < = > ? @ [] ^ _ \ ~ ' { }
Press 0	for	É À È Ê Î Ç Ë Ö 0

D

Specifications

General



Note

This chapter provides a summary of the machines' specifications. For additional specifications visit <http://www.brother.com/> for details.

Printer Type	Laser	
Print Method	Electrophotography by semiconductor laser beam scanning	
Memory Capacity	32 MB	
LCD (liquid crystal display)	16 characters × 2 lines	
Power Source	110 - 120 V AC 50/60 Hz	
Power Consumption ¹	Peak:	1080 W
	Copying (Average):	Approx. 445 W ² at 25 °C (77 °F)
	Sleep (WLAN: On) (Average):	Approx. 3.9 W
	Deep Sleep (Average):	Approx. 1.5 W
	Deep Sleep (WLAN: On) (Average):	Approx. 1.7 W
	Ready (Average):	Approx. 55 W at 25 °C (77 °F)

¹ USB connected to PC

² When making a copy from one sheet

Dimensions

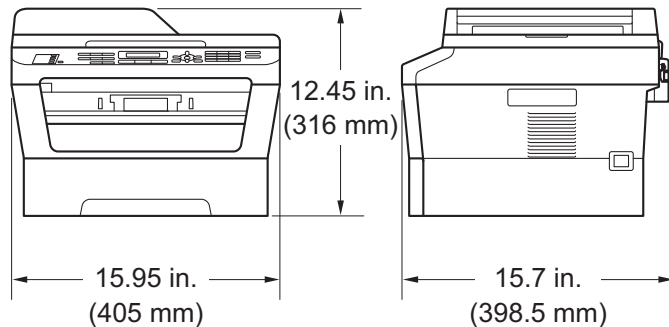

Weight

With Consumables:	(MFC-7360N) 11.4 kg (25.1 lb)
	(MFC-7460DN / MFC-7860DW)
	11.6 kg (25.6 lb)

Noise level	Sound power	
	Operating	(MFC-7360N) LWAd = 6.74 B (A) (MFC-7460DN / MFC-7860DW) LWAd = 6.81 B (A)
	Standby:	LWAd = 4.3 B (A)
	Sound pressure	
	Operating (Printing):	LPAm = 53 dB (A)
	Standby:	LPAm = 30 dB (A)
Temperature	Operating:	50 °F to 90.5 °F (10 to 32.5 °C)
	Storage:	32 °F to 104 °F (0 to 40 °C)
Humidity	Operating:	20 to 80% (without condensation)
	Storage:	10 to 90% (without condensation)
ADF (automatic document feeder)	Up to 35 pages (Staggered) 20 lb (80 g/m ²)	

Document Size

Document Size (Single-sided)

ADF Width: 5.8 to 8.5 in. (147.3 to 215.9 mm)

ADF Length: 5.8 to 14 in. (147.3 to 355.6 mm)

Scanner Glass Width: Max. 8.5 in. (215.9 mm)

Scanner Glass Length: Max. 11.7 in. (297 mm)

Print media

Paper Input	Paper Tray	<ul style="list-style-type: none"> ■ Paper Type: Plain Paper, Thin Paper or Recycled Paper ■ Paper Size: Letter, A4, B5 (ISO/JIS), A5, A5 (Long Edge), B6 (ISO), A6, Executive, Legal ¹ and Folio ¹ ■ Paper Weight: 16 to 28 lb (60 to 105 g/m²) ■ Maximum Paper Tray Capacity: Up to 250 sheets of 20 lb (80 g/m²) Plain Paper
	Manual Feed Slot (Manual)	<ul style="list-style-type: none"> ■ Paper Type: Envelope, Labels ², Thin Paper, Thick Paper, Recycled Paper, Bond Paper or Plain Paper ■ Paper Size: Width: 3 to 8.5 in. (76.2 to 216 mm) Length: 4.6 to 16 in. (116 to 406.4 mm) ■ Paper Weight: 16 to 43 lb (60 to 163 g/m²) ³ ■ Maximum Paper Tray Capacity: One sheet at a time 20 lb (80 g/m²) Plain Paper
Paper Output	Face-Down Output Tray	Up to 100 sheets (<i>face down</i> print delivery to the output paper tray)
	Face-Up Output Tray	One sheet (<i>face up</i> print delivery to the <i>Face up</i> output tray)
Duplex Printing (MFC-7460DN/ MFC-7860DW)	■ Paper Size (Automatic Duplex):	Letter, Legal and Folio
	■ Paper Weight (Automatic Duplex):	16 to 28 lb (60 to 105 g/m ²)
	■ Paper Type (Automatic Duplex):	Plain Paper or Recycled Paper

¹ Legal or Folio size paper is not available in some regions outside the USA and Canada.

² For labels, we recommend removing printed pages from the output paper tray immediately after they exit the machine to avoid the possibility of smudging.

³ 16 to 28 lb (60 to 105 g/m²) for duplex print.

Fax

Compatibility	(MFC-7360N and MFC-7460DN) Group 3 (MFC-7860DW) Super Group 3
Modem Speed	Automatic Fallback: (MFC-7360N and MFC-7460DN) 14,400 bps (MFC-7860DW) 33,600 bps
2-sided (Duplex) Print Receiving	Yes
(MFC-7460DN and MFC-7860DW)	
Scanning Width	Max. 8.2 in. (208 mm)
Printing Width	Max. 8.2 in. (208 mm)
Gray Scale	8 bit/256 levels
Resolution	Horizontal: 203 dot/in. (8 dot/mm) Vertical ■ Standard: 98 line/in. (3.85 line/mm) ■ Fine: 196 line/in. (7.7 line/mm) ■ Photo: 196 line/in. (7.7 line/mm) ■ Superfine: 392 line/in. (15.4 line/mm)
One Touch Dial	8 (4 × 2)
Speed Dial	200 stations
Groups	Up to 8
Broadcasting	258 stations
Automatic Redial	Yes, 1 time after 5 minutes
Memory Transmission	(MFC-7360N and MFC-7460DN) Up to 400 ¹ pages ³ (MFC-7860DW) Up to 500 ² pages ³
Out of Paper Reception	(MFC-7360N and MFC-7460DN) Up to 400 ¹ pages ³ (MFC-7860DW) Up to 500 ² pages ³

¹ 'Pages' refers to the 'ITU-T Test Chart #1' (a typical business letter, Standard resolution, MMR code). Specifications and printed materials are subject to change without prior notice.

² 'Pages' refers to the 'ITU-T Test Chart #1' (a typical business letter, Standard resolution, JBIG code). Specifications and printed materials are subject to change without prior notice.

³ Black & White only

Copy

Color/Monochrome	Monochrome
Copy Width	Max. 8.3 in. (210 mm)
Multiple Copies	Stacks or Sorts up to 99 pages
Reduce/Enlarge	25% to 400% (in increments of 1%)
Resolution	Up to 600 × 600 dpi
First Copy Out Time	Less than 11 seconds (from Ready mode and standard tray)

Scanner

Color/Mono	Yes/Yes
TWAIN Compliant	Yes (Windows® 2000 Professional/Windows® XP/ Windows® XP Professional x64 Edition/Windows Vista®/ Windows® 7) Mac OS X 10.4.11, 10.5.x, 10.6.x ¹
WIA Compliant	Yes (Windows® XP/Windows Vista®/Windows® 7)
Color Depth	48 bit internal / 24 bit external color
Resolution	Up to 19200 × 19200 dpi (interpolated) ² Up to Max 600 × 2400 dpi (optical) (from Scanner Glass) Up to Max 600 × 600 dpi (optical) (from ADF)
Scanning Width	Max. 8.3 in. (210 mm)
Gray Scale	256 levels

¹ For the latest driver updates for the Mac OS X you are using, visit us at <http://solutions.brother.com/>.

² Maximum 1200 × 1200 dpi scanning with the WIA driver in Windows® XP, Windows Vista® and Windows® 7 (resolution up to 19200 × 19200 dpi can be chosen by using the scanner utility)

Printer

Automatic 2-sided (Duplex) Print (MFC-7460DN/ MFC-7860DW)	Yes
Emulations (MFC-7860DW)	PCL6, BR-Script3 (PostScript® 3™ compatible)
Resolution	600 dpi × 600 dpi, HQ1200 (2400 × 600 dpi) quality
Print Speed (Duplex) (MFC-7460DN / MFC-7860DW)	Up to 5 pages/minute (Letter size) ¹
Print Speed	(MFC-7360N) Up to 24 pages/minute (Letter size) ¹ (MFC-7460DN and MFC-7860DW) Up to 27 pages/minute (Letter size) ¹
First Print Out Time	Less than 8.5 seconds (from Ready mode and standard tray)

¹ The print speed may vary depending on the type of document you print.

Interfaces

USB

We recommend use a USB cable (Type A/B) that is no more than 6 feet (2 meters) long.^{1 2}

Ethernet³

Use an Ethernet UTP cable category 5 or greater.

Wireless LAN (MFC-7860DW)

IEEE 802.11 b/g (Infrastructure / Ad-hoc Mode)

- ¹ Your machine has a Hi-Speed USB 2.0 interface. The machine can also be connected to a computer that has a USB 1.1 interface.
- ² Third-party USB ports are not supported.
- ³ See *Network (LAN)* on page 136 and the *Network User's Guide* for detailed network specifications.

Computer requirements

Minimum System Requirements and Supported PC Software Functions								
Computer Platform & Operating System Version		Processor Minimum Speed	Minimum RAM	Recommended RAM	Hard Disk Space to install		Supported PC Software Functions	Supported PC Interface ³
					For Drivers	For Applications		
Windows [®] Operating System ¹	Windows [®] 2000 Professional ⁵	Intel [®] Pentium [®] II or equivalent	64 MB	256 MB	150 MB	500 MB	Printing, PC-Fax ⁴ , Scanning	USB, 10/100 Base Tx (Ethernet), Wireless 802.11 b/g
	Windows [®] XP Home ^{2 6}		128 MB					
	Windows [®] XP Professional ^{2 6}							
	Windows [®] XP Professional x64 Edition ^{2 6}	64-bit (Intel [®] 64 or AMD64) supported CPU	256 MB	512 MB				
	Windows Vista [®] ^{2 6}	Intel [®] Pentium [®] 4 or equivalent 64-bit (Intel [®] 64 or AMD64) supported CPU	512 MB	1 GB				
Windows [®] 7 ^{2 6}	Intel [®] Pentium [®] 4 or equivalent 64-bit (Intel [®] 64 or AMD64) supported CPU	1 GB (32-bit) 2 GB (64-bit)	1 GB (32-bit) 2 GB (64-bit)	650 MB				

Minimum System Requirements and Supported PC Software Functions								
Computer Platform & Operating System Version		Processor Minimum Speed	Minimum RAM	Recommended RAM	Hard Disk Space to install		Supported PC Software Functions	Supported PC Interface ³
					For Drivers	For Applications		
Windows® Operating System ¹	Windows Server® 2003 (print only via network)	Intel® Pentium® III or equivalent	256 MB	512 MB	50 MB	N/A	Printing	10/100 Base Tx (Ethernet), Wireless 802.11 b/g
	Windows Server® 2003 x64 Edition (print only via network)	64-bit (Intel®64 or AMD64) supported CPU						
	Windows Server® 2008 (print only via network)	Intel® Pentium® 4 or equivalent 64-bit (Intel®64 or AMD64) supported CPU	512 MB	2 GB				
	Windows Server® 2008 R2 (print only via network)	64-bit (Intel®64 or AMD64) supported CPU						
Macintosh Operating System	Mac OS X 10.4.11 10.5.x	PowerPC® G4/G5 Intel® Core™ Processor	512 MB	1 GB	80 MB	400 MB	Printing, PC-Fax Send ⁴ , Scanning	USB, 10/100 Base Tx (Ethernet), Wireless 802.11 b/g
	Mac OS X 10.6.x	Intel® Core™ Processor	1 GB	2 GB				

¹ Internet Explorer® 6.0 or greater.

² For WIA, 1200 x 1200 resolution. Brother Scanner Utility enables to enhance up to 19200 x 19200 dpi.

³ Third-party USB ports are not supported.

⁴ PC-Fax supports black and white only.

⁵ PaperPort™ 11SE supports Microsoft® SP4 or higher for Windows® 2000.

⁶ PaperPort™ 12SE supports Microsoft® SP3 or higher for Windows® XP and SP2 or higher for Windows Vista® and Windows® 7.

For the latest driver updates, visit <http://solutions.brother.com/>.

All trademarks, brand and product names are property of their respective companies.

Consumable items

Toner Cartridge	Starter Toner Cartridge:	Approx. 700 pages (Letter) ¹
	Standard Toner Cartridge: TN-420	Approx. 1,200 pages (Letter) ¹
	High-Yield Toner Cartridge: TN-450	Approx. 2,600 pages (Letter) ¹
Drum Unit	DR-420	Approx. 12,000 pages (Letter) ²

¹ Approx. cartridge yield is declared in accordance with ISO/IEC 19752.

² Drum yield is approximate, and may vary by type of use.

Network (LAN)



Note

For details about the full Network specifications, see the *Network User's Guide*.

LAN You can connect your machine to a network for Network Printing, Network Scanning, PC-Fax Send, PC-Fax Receive (Windows® only) and Remote Setup ¹. Also included is Brother BRAdmin Light ² Network Management software.

Security Protocols

Wired APOP, POP before SMTP, SMTP-AUTH

Wireless APOP, POP before SMTP, SMTP-AUTH

Wireless Network Security (MFC-7860DW) WEP 64/128 bit, WPA-PSK (TKIP/AES), WPA2-PSK (AES)

Wireless Network Setup Support Utility (MFC-7860DW) **AOSS™** Yes

WPS Yes

¹ See *Computer requirements* on page 133.

² BRAdmin Professional and Web BRAdmin are available as a download from <http://solutions.brother.com/>.

A

Accessories and supplies	ii
Address Book	8
ADF (automatic document feeder)	
using	22
Answering machine (TAD)	
connecting	35
Apple Macintosh	
See Software User's Guide	
Automatic	
fax receive	29
easy receive	31
fax redial	40

B

Brother	
accessories and supplies	ii
Brother numbers	i
Customer Service	i
FAQs (frequently asked questions)	i
product support	i
service centers	i
Solutions Center	i
warranties	iii, iv, vi

C

Cleaning	
corona wire	58
Connecting	
external TAD (answering machine)	35
external telephone	36
Consumable items	52
ControlCenter	
See Software User's Guide	
Control panel overview	6
Copy	48
keys	8
Cordless telephone (non-Brother)	37
Custom Ringing	32

D

Data Ident-A-Call	32
Dialing	
a pause	42
automatic fax redial	40
manual	39
one touch	39
speed dial	39
using the Address Book key	40
Distinctive ring	32
choosing ring pattern	33
setting ring pattern	34
turning off	34
Document	
how to load	22, 23
Drum unit	
cleaning	58
replacing	59
Duplex	
printing	127

E

Envelopes	13, 17, 18, 20
Equalization	91
Error messages on LCD	64
Comm. Error	64
Drum Error	60
Drum Stop	60
Init Unable XX	66
No Paper	66
Out of Memory	67
Print Unable XX	67
Replace Drum	60
Replace Toner	53
Scan Unable XX	68
Toner Ended	53
Toner Low	53
Extension telephone, using	38
External telephone, connecting	36

F

Fax codes	
changing	38
fax receive code	38
telephone answer code	38
Fax, stand-alone	
receiving	27
easy receive	31
from extension telephone	38
ring delay, setting	30
telephone line interference	91
sending	25
telephone line interference	91
Fax/Tel mode	
answering at extension telephones	38
easy receive	31
F/T ring time (double-ring)	30
fax receive code	38
ring delay	30
telephone answer code	38
Folio	17

G

Gray scale	128, 130
------------	----------

H

HELP	
LCD messages	104
Menu Table	105
Hook key	8, 37

I

Ident-A-Call	32
Ident-A-Ring	32

J

Jacks	
EXT	
external telephone	36
TAD (answering machine)	35

L

Labels	11, 17, 18, 21
LCD (liquid crystal display)	8, 104

M

Machine information	
how to reset the machine	103
reset functions	102
serial number	102
Macintosh	
See Software User's Guide	
Maintenance, routine	
replacing	
drum unit	59
toner cartridge	53
Manual	
dialing	39
receive	27, 29
Menu Table	105
Mode, entering	
copy	48
fax	25
scan	8
Multi-line connections (PBX)	36

N

Network	
Printing	See Network User's Guide
Network	
Scanning	See Software User's Guide

O

One touch	
changing	46
setting up	42
using	39
OPC drum	95
Out of Memory message	67

P

Paper	17, 127
how to load	9
in multi-purpose tray	11
in paper tray	9
recommended	17, 18
size	18
tray capacity	18
type	18
Personalized Ring	32
Print	
difficulties	82, 86
emulation	131
quality	88
resolution	131
specifications	131
Print quality	92
Programming your machine	104

Q

Quality	
printing	88
Quick dial	42
group dial	
changing	46
one touch dial	
changing	46
custom scan profile	42
setting up	42
using	39
Search	40
speed dial	
changing	46
custom scan profile	44
setting up	44
using	39

R

Redial/Pause key	40, 42
Replacing	
drum unit	59
toner cartridge	53
Reports	
Transmission Verification	26
Resolution	
copy	129
fax (standard, fine, superfine, photo)	128
print	131
scan	130
Resolution key	8
Ring delay, setting	30
RingMaster	32

S

Safety Instructions	viii
Scanner glass	
using	23
Secure key	8
Serial number	
how to find	See inside front cover
Service centers	i
SimpleBiz Fax & Alternate Number	
Ringing	32
Smart Ring	32
Speed dial	
changing	46
setting up	44
using	39

T

TAD (telephone answering device),	
external	29
connecting	35
recording OGM	36
Teen Ring	32
Telephone line	
connections	35
difficulties	82
interference	91
multi-line (PBX)	36
Text, entering	122
Toner cartridge	
replacing	53
Troubleshooting	64
document jam	70, 71
error messages on LCD	64
if you are having difficulty	
copy quality	86
incoming calls	85
network	89
paper handling	88
print quality	88
printing	82, 86
receiving faxes	83
scanning	87
sending faxes	85
software	87
telephone line	91
maintenance messages on LCD	64
paper jam	72, 73, 75, 80

V

Voice Mail	32
VoIP	91

W

Warranties	
Canada	vi
Notice-Disclaimer	iii
USA	iv
Windows®	
See Software User's Guide	
World Wide Web	i
Wireless Network	
See Quick Setup Guide and Network User's Guide	

EQUIPMENT ATTACHMENT LIMITATIONS (Canada only)

NOTICE

This product meets the applicable Industry Canada technical specifications.

NOTICE

The Ringer Equivalence Number is an indication of the maximum number of devices allowed to be connected to a telephone interface. The termination on an interface may consist of any combination of devices subject only to the requirement that the sum of the RENs of all the devices does not exceed five.

Brother International Corporation
100 Somerset Corporate Boulevard
P.O. Box 6911
Bridgewater, NJ 08807-0911 USA

Brother International Corporation (Canada) Ltd.
1 rue Hôtel de Ville,
Dollard-des-Ormeaux, QC, Canada H9B 3H6

brother®

Visit us on the World Wide Web
<http://www.brother.com/>

These machines are approved for use in the country of purchase only. Local Brother companies or their dealers will only support machines purchased in their own countries.