



Kodak

i2400/i2600/i2800 Scanners

User's Guide

Safety

User Precautions

- Place the scanner on a sturdy, level work surface capable of supporting 5.5 kg (12 lbs).
- Do not install the scanner in a location subject to dust, humidity or steam. This may cause electrical shock or a fire. Only use the scanner and power supply indoors in a dry location.
- Make sure the electrical power outlet is located within 1.52 meters (5 feet) of the scanner and is easily accessible.
- Use only the power cord that was provided with the scanner. Using any other power cord may cause electrical shock and/or damage the product.
- Be sure the power cord is securely plugged into the wall outlet. Failure to do so may cause electrical shock or fire.
- Do not damage, knot, cut or modify the power cord. This may cause electrical shock or fire.
- The scanner requires a dedicated power outlet. Do not use an extension cord or power strip with the scanner.
- Use only the AC adapter that is supplied with the scanner. Do not use the scanner's AC adapter with any other product.
- Leave sufficient space around the power outlet so it can be easily unplugged in case of an emergency.
- Do not use the scanner if it becomes inordinately hot, has a strange odor, emits smoke, or makes unfamiliar noises. Immediately stop the scanner and disconnect the power cord from the power outlet. Contact Kodak Service.
- Do not disassemble or modify the scanner or the AC power adapter.
- Do not move the scanner with the power cord and interface cable attached. This may cause damage to the cord/cable. Remove the power cord from the wall outlet before moving the scanner.
- Follow the Kodak recommended cleaning procedures. Do not use air, liquid or gas spray cleaners. These cleaners displace dust, dirt and debris to another location within the scanner, which may cause the scanner to malfunction.
- Material Safety Data Sheets (MSDS) for chemical products are available on the Kodak website at: www.kodak.com/go/msds. When accessing the MSDSs from the website, you will be required to provide the catalog number of the consumable you want the Material Safety Data Sheet for. See the section entitled, "Supplies and consumables" later in this guide for supplies and catalog numbers.

Environmental information

- The *Kodak i2400/i2600/i2800* Scanners are designed to meet worldwide environmental requirements.
- Guidelines are available for the disposal of consumable items that are replaced during maintenance or service; follow local regulations or contact Kodak locally for more information.
- Disposal of this equipment may be regulated due to environmental considerations. For disposal or recycling information, contact your local authorities or, in the USA, visit the Electronics Industry Alliance website: www.eiae.org.
- The product packaging is recyclable.
- Parts are designed for reuse and recycling.
- The *Kodak i2400/i2600/i2800* Scanners are Energy Star compliant and are shipped from the factory with the default time set to 15 minutes.

European Union



This symbol indicates that when the last user wishes to discard this product, it must be sent to appropriate facilities for recovery and recycling. Please contact your local Kodak representative or refer to www.kodak.com/go/recycle for additional information on the collection and recovery programs available for this product.

Acoustic emission

Maschinenlärminformationsverordnung – 3, GSGV
Der arbeitsplatzbezogene Emissionswert beträgt <70 dB(A).

[Machine Noise Information Ordinance — 3, GSGV
The operator-position noise emission value is <70 dB(A).]

EMC statements

United States: This equipment has been tested and found to comply with the limits for a Class B digital device pursuant to Part 15 of the FCC rules. These limits are designed to provide reasonable protection against harmful interference in a residential installation. This equipment generates, uses, and can radiate radio frequency energy and, if not installed and used in accordance with the instruction manual, may cause harmful interference to radio communications. However, there is no guarantee that interference will not occur in a particular installation. If this equipment does cause harmful interference to radio or television reception, which can be determined by turning the equipment off and on, the user is encouraged to try to correct the interference by one or more of these measures:

- Reorient or relocate the receiving antenna.
- Increase the separation between the equipment and receiver.
- Connect the equipment into an outlet on a circuit different from that to which the receiver is connected.
- Consult the dealer or an experienced radio/TV technician for additional suggestions.

Any changes or modifications not expressly approved by the party responsible for compliance could void the user's authority to operate the equipment. Where shielded interface cables have been provided with the product or specified additional components or accessories elsewhere defined to be used with the installation of the product, they must be used in order to ensure compliance with FCC regulation.

Korea: As this equipment has obtained EMC registration for household use, it can be used in an area including residential areas.

이 기기는 가정용으로 전자파적합등록을 한 기기로서 주거지역에서는 물론 모든 지역에서 사용할 수 있습니다.

Japan: This is a Class B product based on the standard of the Voluntary Control Council for interference by information Technology Equipment (VCCI). If this is used near a radio or television receiver in a domestic environment, it may cause radio interference. Install and use the equipment according to the instruction manual.

この装置は、情報処理装置等電波障害自主規制協議会（VCCI）の基準に基づくクラスB情報技術装置です。この装置は、家庭環境で使用することを目的としていますが、この装置がラジオやテレビジョン受信機に近接して使用されると、受信障害を引き起こすことがあります。
取扱説明書に従って正しい取り扱いをして下さい。

OVERVIEW

1-1

INSTALLATION

2-1

SCANNING

3-1

MAINTENANCE

4-1

TROUBLESHOOTING

5-1

APPENDICES

A & B

1 Overview

Contents

Supporting documentation	1-2
Accessories.....	1-2
What's in the box	1-2
Scanner components	1-3



Kodak i2400 Scanner



Kodak i2600/i2800 Scanner

The *Kodak i2400/i2600/i2800* Scanners are compact document scanners perfect for workgroups and other decentralized applications. All scanner models have a feature that allows you to tilt the scanner to an angle for scanning, then back to a vertical position for storage. Included with each model is Smart Touch functionality which allows you to send your documents to email, print or various applications with the touch of a button. The i2400/i2600/i2800 Scanners also support the optional *Kodak A4 Flatbed Accessory*.

- **Kodak i2400 Scanner** — duplex scanner that scans 30 pages per minute at 200 and 300 dpi in black and white, color and grayscale. The i2400 Scanner allows you to scan 50 documents at a time and the dual LED indirect light provides excellent image quality.
- **Kodak i2600 Scanner** — duplex scanner that scans 50 pages per minute at 200 and 300 dpi in black and white and grayscale; 40 pages per minute at 200 dpi in color. The i2600 Scanner allows you to scan 75 documents at a time and the dual LED indirect light provides excellent image quality.
- **Kodak i2800 Scanner** — duplex scanner that scans 70 pages per minute at 200 and 300 dpi in black and white and grayscale; and 60 pages per minute at 200 dpi in color. The i2800 Scanner allows you to scan 100 documents at a time and the dual LED indirect light provides excellent image quality.

NOTE: This User's Guide provides information and procedures for the *Kodak i2400/i2600/i2800* Scanners. The information in this guide is for use with all scanner models unless otherwise noted.

Supporting documentation

In addition to this User's Guide, the following documentation is also available:

- **Installation Guide** — provides a step-by-step procedure for installing the scanner.
- **Scanning Setup Guides** — the TWAIN Datasource and ISIS Driver are included with the *Kodak i2400/i2600/i2800 Scanners*. The Scanning Setup Guides explain how to use basic image processing features and is provided on the Installation CD in PDF format.
- **Smart Touch User's Guide** — provides information and procedures on how to use Smart Touch functionality. This guide is provided on the Installation CD in PDF format.
- **Reference Guide** — provides easy visual steps for cleaning your scanner. Keep this guide close to the scanner so you can use it as an easy reference.

Accessories

- **Kodak White Background Accessory** — if you are scanning translucent or very thin documents, this accessory will reduce black background bleed-through while scanning which produces whiter images. CAT No. 892 7717
- **Kodak A4 Flatbed Accessory** — the *Kodak A4 Flatbed* adds scanning capability for exception documents up to 8.5 x 11-inch (A4) size paper to your *Kodak i2400/i2600/i2800 Scanner*. CAT No. 155 0268
- **Kodak Black Background Accessory for A4 Flatbed** — this flatbed cover can be used if you are scanning documents with primarily a white background and you want a defined black border on your images. CAT No. 863 6870

What's in the box

Before you begin open the box and check the contents:

- *Kodak i2400, i2600 or i2800 Scanner*
- USB 2.0 cable
- Power supply
- AC power cord bundles
- Sample Cleaning Kit
- Installation CD
- Application CDs
- Warranty/Registration sheets
- Printed User's Guide, English
- Printed Reference Guide, English
- Installation Guide
- Service & Support Contact Information sheets
- Miscellaneous flyers

Scanner components

The *Kodak i2800* and *i2600* Scanners have a graphical display and look like the illustration below. The *Kodak i2400* Scanner is the same as the illustration below except there is a function window which is smaller than the graphical display.

Front view

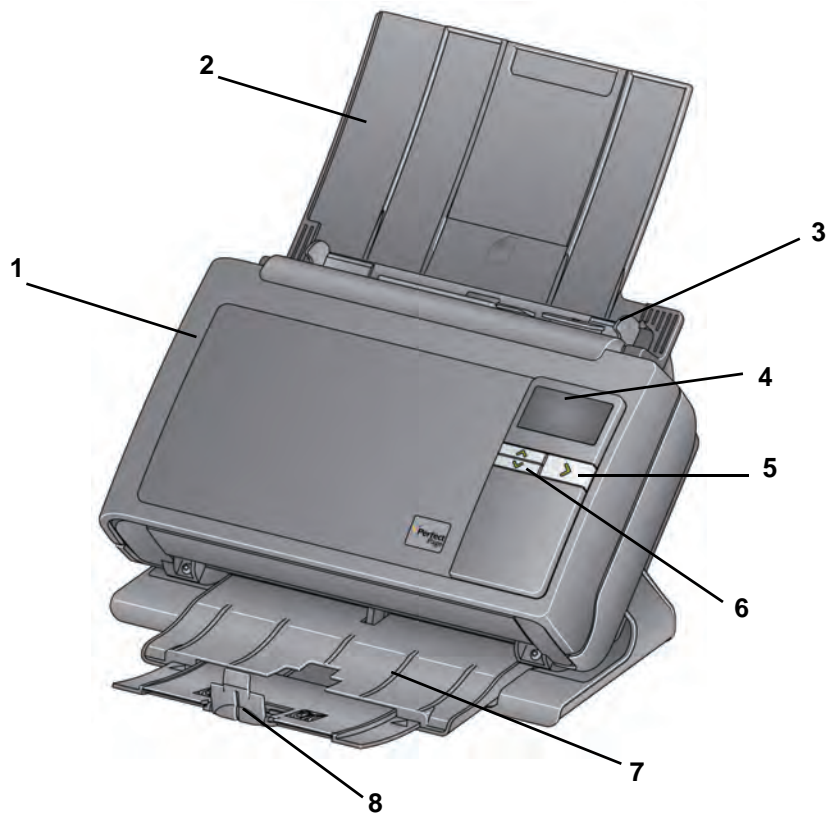

- 1 Scanner cover** — provides access to internal components; such as, the imaging area and the feed and separation modules.
- 2 Input tray** — depending on your scanner model, the input tray holds up to the following number of documents (20 lb./75 g/m²):
 - i2400:** 50
 - i2600:** 75
 - i2800:** 100The input tray can be extended to accommodate documents longer than 27.9 cm (11 inches).
- 3 Side guides** — can be moved in and out to accommodate the size of the documents you are scanning.
- 4 Function window/Graphical display** — displays 0 - 9. These numbers correspond to a predefined function. **U** or **E** is displayed if an error is encountered. If you have a *Kodak i2600* or *i2800* Scanner, messages will also be displayed.
- 5 LED/Start button** — illuminates to indicate scanner status (i.e., power on) and launches the selected application that is associated with the displayed number in the Function window.

- 6 Up and Down Scroll buttons** — allows you to select or scroll through predefined functions or applications by pressing the Up or Down scroll buttons.

NOTE: The LED/Start button, Scroll button and Function window are used with Smart Touch functionality.

- 7 Output tray** — collects the scanned documents. When the scanner is placed in the vertical position the output tray slides underneath the scanner thus making the scanner compact and easy to store. When the scanner is in use and tilted, the output tray can be pulled out and extended to accommodate documents up to 35.56 cm (14 inches) in length.

- 8 End stops** — can be lifted up when scanning small documents for better document stacking. When the output tray is completely extended, another pair of end stops is located at the end of the output tray. Lift these end stops as necessary for better document stacking of long documents.

Back view

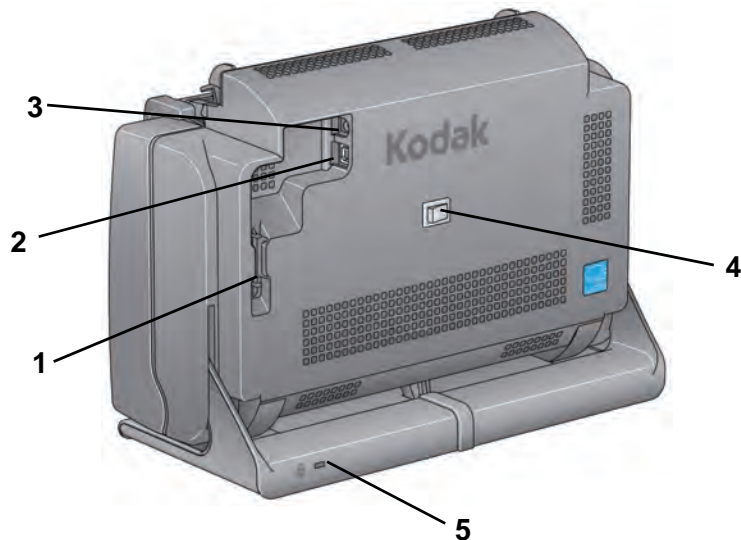

- 1 Routing channel** — allows you to secure the USB cable and power cord to protect them when the scanner is moved.
- 2 USB port** — connects the scanner to the PC.
- 3 Power port** — connects the power supply to the scanner.
- 4 Power switch** — turns the scanner on and off.
- 5 Security lock port** — connects a security lock to the scanner. You can purchase a standard security lock at an office supply store. Refer to the instructions provided with the security lock for installation procedures.

Inside view

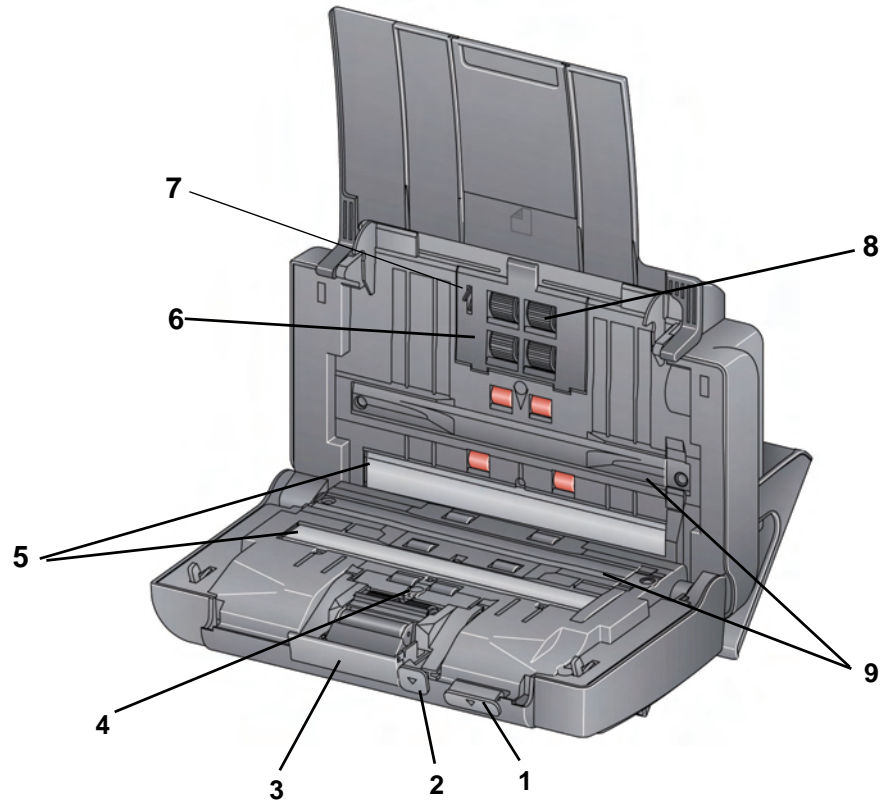

- 1 Scanner cover release lever** — opens the scanner to allow access to the paper path for cleaning or clearing a document jam. The scanner must be in the tilted position to open the scanner cover.
- 2 Gap release lever** — allows you to manually adjust the space between the feed module and separation module for documents that require special handling, e.g., documents that are badly torn.
- 3 Separation module release lever** — push the release lever down to remove the separation module for cleaning or replacement.
- 4 UDDS sensor** — used to detect multifeeds and document edges.
- 5 Imaging guides** — for optimum image quality, keep the imaging area clean.
- 6 Feed module cover** — this cover needs to be removed when cleaning or replacing the feed module or feed module tires.
- 7 Paper present sensor** — detects the presence of documents in the input tray.
- 8 Feed module assembly** — provides smooth document feeding and separation of various sizes, thicknesses and textures of documents.
- 9 Background strips** — these black background strips can be interchanged with the White Background Accessory, which can be used if you are scanning translucent or very thin documents to reduce black background bleed-through.

2 Installation

Contents

Installing the scanner	2-1
Installing the <i>Kodak</i> Driver Software	2-1
Connecting the power cord and USB cable	2-2
Turning on the scanner	2-3

Installing the scanner

This section provides detailed information of the *Installation Guide* that is provided with your scanner. Follow these steps in the order they are provided to install your scanner.

NOTE: If you have already performed all of the steps in the *Installation Guide*, skip this section.

Installing the *Kodak* Driver Software

1. Insert the *Kodak* i2400/i2600/i2800 Scanners Installation CD in the CD-ROM drive. The installation program starts automatically.
2. Select **Install Scanner Software**.

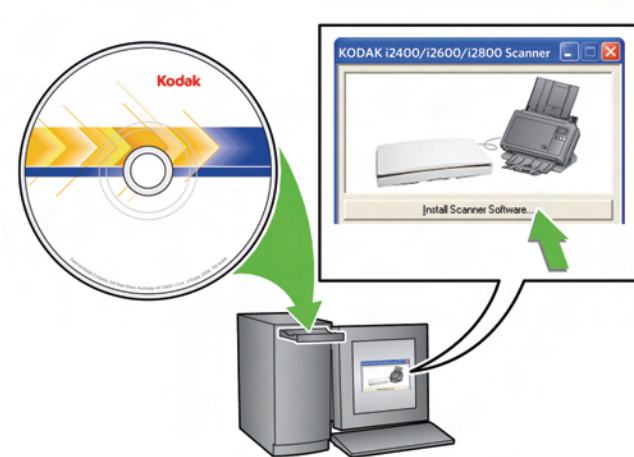

NOTES:

- If the CD does not start automatically, open the My Computer icon on your desktop. Double-click the icon indicating your CD-ROM drive, then double-click on **setup.exe**.
- If the message **Portions of this application are already installed** is displayed, click **Yes** to continue the installation process. Any previously installed *Kodak* Scanner software that is shared with this scanner will be updated.

3. Click **Next** when the Welcome screen is displayed.
4. Click **I Agree** after you have read and agreed with the terms of the Software License Agreement. The installation will start and several progress screens will be displayed.
5. Click **Finish** when the installation is complete.
6. Remove the Installation CD from the CD-ROM drive.

Connecting the power cord and USB cable

When the drivers have been installed, connect the power supply, power cord and USB cable to the scanner. Refer to the illustration below for making proper connections. Make sure the power outlet is located within 1.52 metres (5 feet) of the scanner and is easily accessible.

1. Select the appropriate AC power cord from the supply of power cords packed with your scanner.
2. Attach the power cord to the power supply.

NOTE: Be sure that the power cord is securely attached to the power supply.

3. Plug the output power cord from the power supply into the power port on the scanner.
4. Plug the other end of the power cord into the wall outlet.

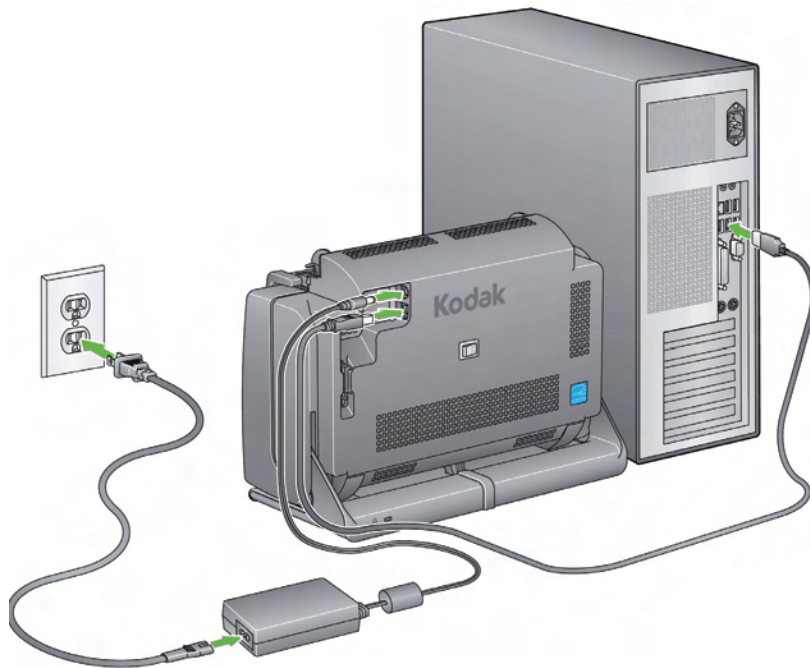

NOTE: The green LED on the power supply indicates the power is on.

5. Attach the USB cable to the scanner USB port, located on the back of the scanner.
6. Attach the other end of the USB cable to the proper USB port on your PC.

7. Secure the power cord and USB cable into the routing channel on the back of the scanner.

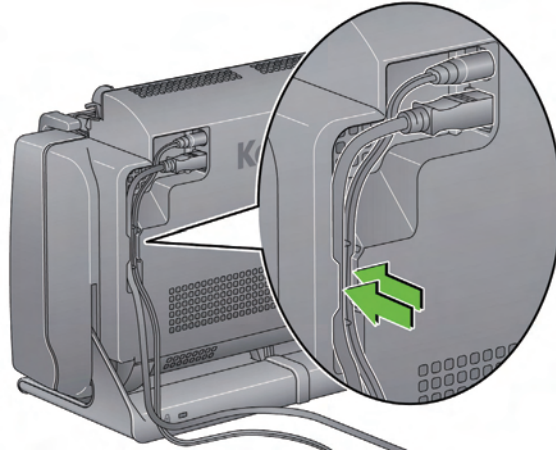

Turning on the scanner

- Press the button on the back of the scanner to the On (I) position.

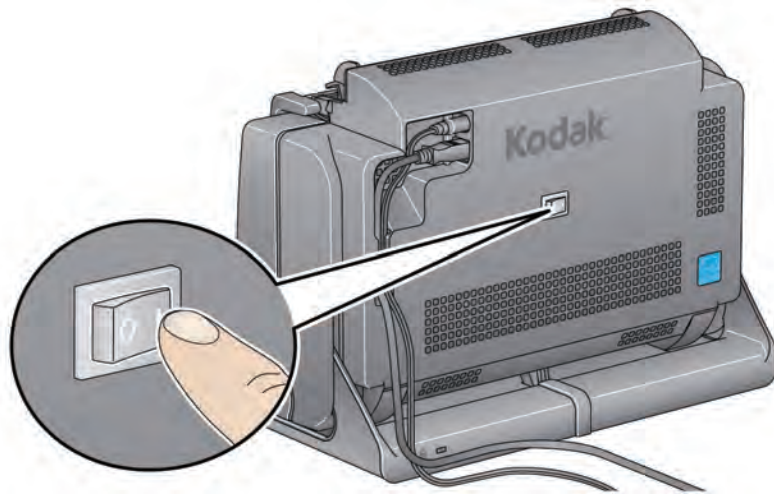

When you turn on the scanner, the LED/Start button on the front of the scanner will flash as the scanner goes through a series of self tests.

Please wait while the operating system synchronizes the scanner with the installed software.

When the installation process is complete and ready to scan, the LED/Start button will stop flashing and stay green.

3 Scanning

Contents

Getting your scanner ready to scan 3-1
Getting your documents ready to scan 3-3
Selecting your scanning application 3-4
Scanning with Smart Touch 3-5

Getting your scanner ready to scan

1. Be sure the scanner is on and ready to scan (LED/Start button will be green and constant).
2. Tilt the scanner.

- **Tilt position:** Use the scanner in this position when scanning. Using both hands, rotate the scanner body away from you. When you tilt the scanner, the output tray will slide out from underneath the scanner.



- **Storage position:** Use this position to store the scanner when not in use. Rotate the scanner toward you.



3. Adjust the side guides (by sliding them in or out) to accommodate the size of documents you are scanning.

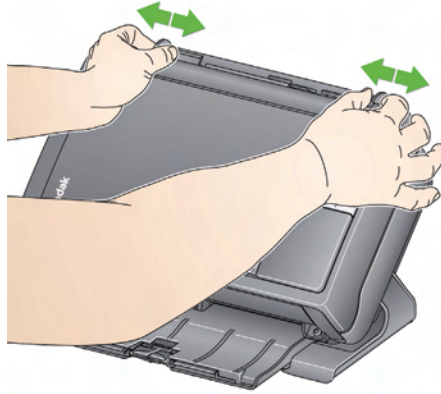

4. Adjust the input tray. You can scan documents with the input tray open or closed. Feed documents with the input tray open if you are scanning a batch of documents.



Input tray - open



Input tray - closed

If space is limited and you want to close the input tray, you can easily feed documents one at a time.

5. Adjust the output tray to accommodate your scanning needs. The output tray has several positions and extensions. Two end stops are available to accommodate document stacking. Lift these end stops as needed for scanning small or longer documents.

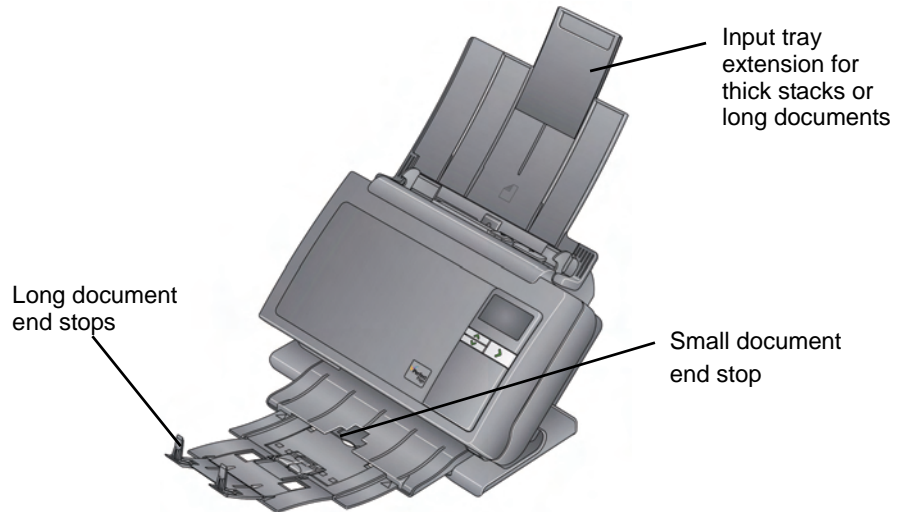

- The output tray can be extended to accommodate documents up to 35.56 cm (14 inches) in length.

Getting your documents ready to scan

1. Standard paper size documents feed easily through the scanner. When organizing your documents for scanning, stack the documents so the lead edges are aligned and centered in the input tray. This allows the feeder to introduce documents into the scanner one at a time.
2. Remove all staples and paper clips before scanning. Staples and paper clips on documents may damage the scanner and documents.
3. All inks and correction fluids on the paper must be dry before scanning is started.
4. Place the documents you want to scan in the input tray. Be sure the front side of your document(s) is positioned against the input tray and the top of the document(s) is inserted into the input tray first.

Depending on your scanner model, the input tray capacity (20 lb./75 g/m² bond paper) is as follows:

- **i2400 Scanner** — holds up to 50 documents
- **i2600 Scanner** — holds up to 75 documents
- **i2800 Scanner** — holds up to 100 documents

Selecting your scanning application

Smart Touch — Kodak provides Smart Touch functionality which allows you to quickly and easily perform common scanning tasks; such as:

- scan and share incoming client correspondence with a co-worker in a branch office
- create a searchable PDF of a printed report
- scan, fax/print an invoice
- scan a photo to add to a presentation

The following predefined task shortcuts are available for you to use. You can modify and rename any of the shortcuts to create your own custom tasks. You can also preview and easily edit images (zoom, pan, rotate, crop, and much more) before they are sent to their destination.

Color PDF — scans a color document(s) and saves it as a PDF file.

Black and White PDF — scans a document(s) and saves it as a black and white PDF file.

Black and White RTF — scans a black and white document that can be opened using a word processing application. The document will be saved as a RTF file.

Color JPEG — scans a color photograph(s) and saves it as a JPG file.

Black and White Single-page TIFF — scans a black and white document and saves the images to individual single-page TIFF files.

Black and White Multi-page TIFF — scans a black and white document and saves all of the images in a multi-page TIFF file.

E-mail Black and White PDF — scans a document(s) and sends a black and white PDF to an email recipient.

Custom Color PDF — scans the document and launches the Smart Touch Editing window. When you have finished editing the image and clicked **Done**, the image will be displayed as a PDF file.

Custom Color File(s) — allows you to setup the scanner settings before the document is scanned. The document will be saved as a color JPG file.

These scanning applications are also included with your scanner:

ScanSoft PaperPort — use this software to scan your documents into organized files that you can quickly find, use and share. PaperPort provides a unique visual desktop that displays thumbnails of your documents so you can easily browse and locate information fast.

ScanSoft OmniPage — this productivity application delivers accurate document conversion for turning paper and PDF files into electronic files you can edit, search and share. Its OCR engines and precise formatting ensure that your electronic documents look exactly like the original - complete with text, graphics, columns and tables.

NOTE: Smart Touch was installed when you installed the *Kodak Driver Software*. The scanning applications listed above are provided on separate CDs that were included with your scanner. Refer to the application's User's Guide for instructions on how to install and use it. The Smart Touch User's Guide can be found by clicking on the Help button within the Smart Touch application.

Scanning with Smart Touch

The following steps are an example of creating a **Black and White PDF** using Smart Touch. For more information about Smart Touch, see the *User's Guide for Smart Touch* on the Installation CD.

1. Press the **Scroll** button until number **2** is displayed in the function window. You may scroll up or down to the desired function depending on which Scroll button is used.
2. Press the **LED/Start** button.

The document will be scanned and the resulting image will be placed in the Output folder in the Smart Touch directory under "My Documents".

4 Maintenance

Contents

Opening the scanner cover.....	4-1
Cleaning procedures.....	4-2
Cleaning the rollers	4-2
Cleaning the separation module.....	4-3
Cleaning the feed module	4-4
Vacuuming the scanner.....	4-5
Cleaning the imaging area	4-6
Running a transport cleaning sheet.....	4-6
Replacement procedures	4-7
Replacing the separation module and tires	4-7
Replacing the pre-separation pad	4-9
Replacing the feed module and tires	4-10
Adjusting the pre-separation roller tension	4-12
Supplies and consumables	4-12

Opening the scanner cover

1. Before opening the scanner cover, be sure the input tray is in the open position and the scanner is tilted.
2. Press and hold the scanner cover release lever and pull the scanner cover down.



3. When you finish cleaning the scanner or replacing a part, close the scanner cover with both hands.

Cleaning procedures

Your scanner needs to be cleaned periodically. If your documents do not feed easily, if several documents feed at the same time or if streaks appear on your images, it is time to clean your scanner. The section entitled, "Supplies and consumables" at the end of this chapter provides a listing of the supplies required to clean your scanner.

IMPORTANT: Only use cleaners such as those provided through Kodak Parts Services. Do not use household cleaners.

Allow surfaces to cool to ambient temperature before use. Do not use cleaners on hot surfaces.

Use adequate ventilation. Do not use cleaners in confined areas.

NOTES:

- Before cleaning, disconnect the electrical power.
- Wash your hands with soap and water after performing maintenance procedures.

Cleaning the rollers

1. Open the scanner cover.
2. With a roller cleaning pad, wipe the feed rollers from side to side. Rotate the feed rollers to clean the entire surface.

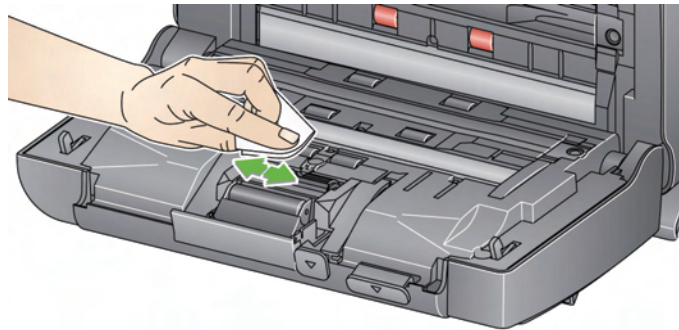

IMPORTANT: The roller cleaning pad contains sodium lauryl ether sulfate which can cause eye irritation. Refer to the MSDS for more information.

3. Dry the rollers with a lint-free cloth.

Cleaning the separation module

The separation module should be removed from the scanner for best cleaning results.

1. Push the separation module up to snap out and lift it out of position.

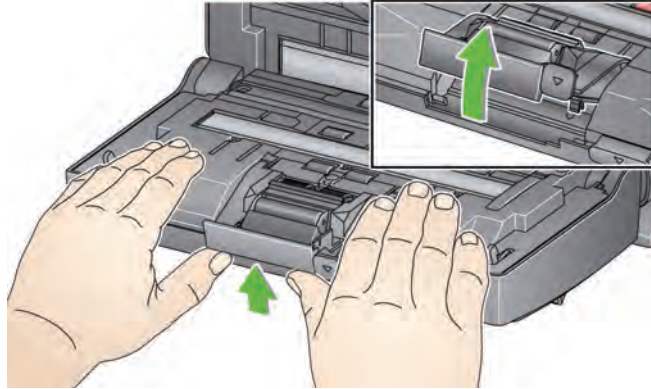

2. Manually rotate and wipe the separation module tires with a roller cleaning pad.

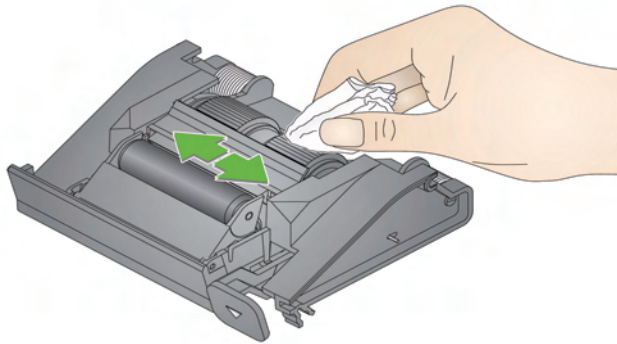

3. Inspect the separation module.

If the separation module tires show signs of wear or damage, replace the tires or the separation module. See “Replacement procedures” for more information.

4. Insert the separation module by aligning the tabs with the slots and snapping it into position.

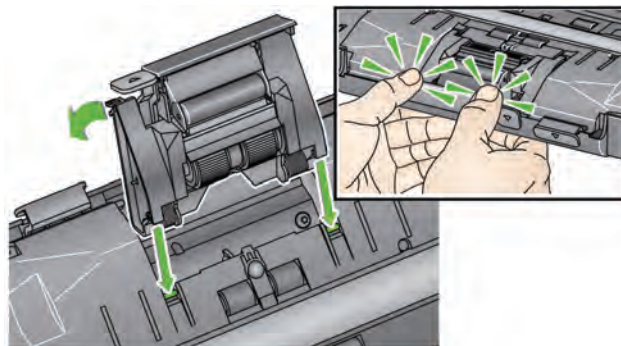

Cleaning the feed module

NOTE: Be careful not to damage the paper present sensor when removing or cleaning around the feed module.

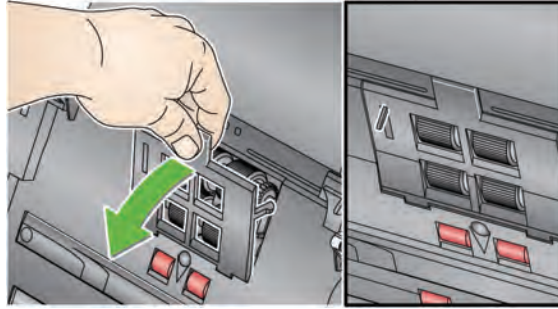

1. Pull against the raised edge of the feed module cover and lift it up and out of position.

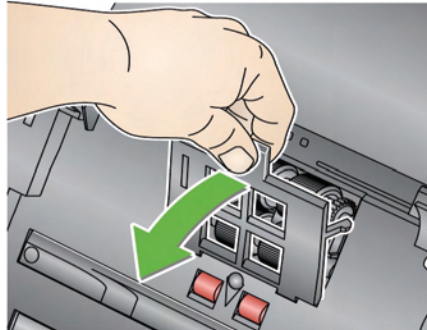

2. Rotate the feed module forward and push it to the left to lift it out of position.

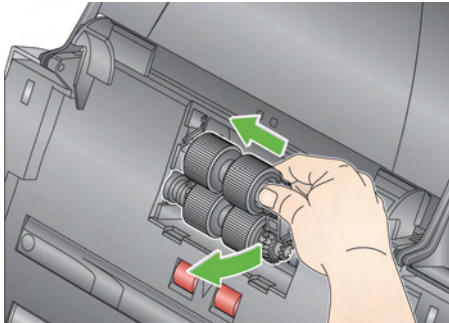

3. Manually rotate and wipe the feed module tires with a roller cleaning pad.

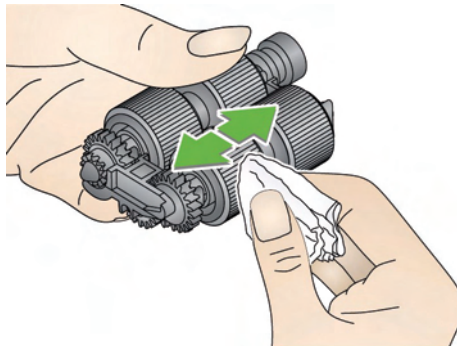

4. Inspect the feed module.

If the feed module tires show signs of wear or damage, replace the tires or the feed module. See the “Replacement procedures” for more information.

5. Use a vacuum or cleaning pad to remove dust and debris from the feed module area.

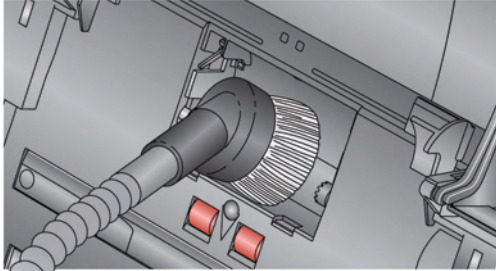

6. Reinstall the feed module by aligning the pins and pushing it toward the left to fit it into position. Be sure the gears are aligned and it snaps into place. Roll the feed module back into place.

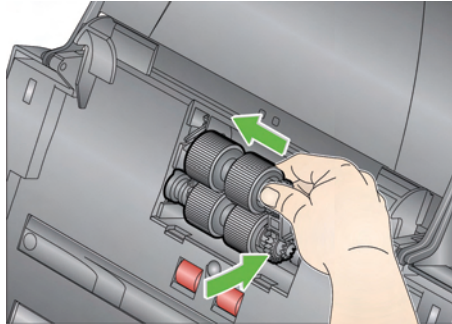

7. Reinstall the feed module cover by aligning the tabs with the slots and pushing it back into position until it snaps into place.

Vacuuming the scanner

Before cleaning the imaging area, it is suggested that you vacuum the inside of the scanner to remove any dust and debris.

Cleaning the imaging area

1. Wipe the upper and lower imaging area using a Brilliance Detailer wipe (Step 1) or Staticide wipe. Be careful not to scratch the imaging area when cleaning.

IMPORTANT: Staticide wipes contain isopropanol which can cause eye irritation and dry skin. Wash your hands with soap and water after performing maintenance procedures. Refer to the MSDS for more information.

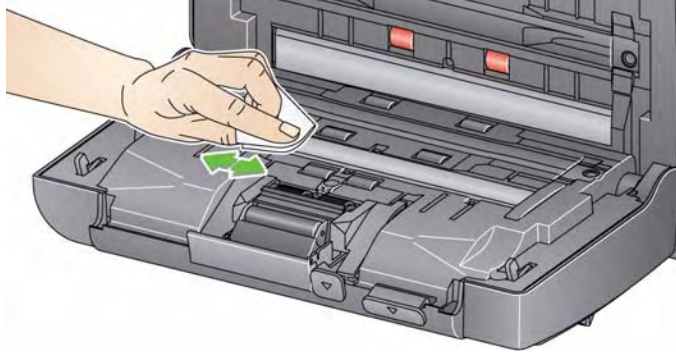

2. Wipe the upper and lower imaging area again using a Brilliance wipe (Step 2) or an almost dry Staticide wipe to remove any streaks.
3. When finished, close the scanner cover with both hands.

Running a transport cleaning sheet

1. Remove the wrapping from the Transport Cleaning Sheet.
2. Adjust the side guides to fit the cleaning sheet.
3. Place a transport cleaning sheet in the input tray (adhesive side facing you) in portrait orientation.
4. Using your scanning application, scan the transport cleaning sheet.
5. After the transport cleaning sheet is scanned, turn it over (adhesive side facing the input tray) and scan it again.
6. Open the scanner cover and wipe the imaging area with a lint-free cloth.
7. Close the scanner cover with both hands.
8. Check your image quality.
9. If necessary, repeat this procedure until all residue is removed from the rollers.

NOTE: When a transport cleaning sheet gets very dirty, discard it and use a new one.

Replacement procedures

Kodak Scanners use replaceable tires that can feed a wide range of document types, sizes and thicknesses. Tire life and performance will vary based on the customer's document set, the frequency of cleaning the paper path and tires, and following the recommended schedule for changing tires. Nominal tire life is approximately 125,000 pages. Usage figures are not guaranteed. Customer-operating environments, document type, the condition of documents being scanned, and not following the recommended cleaning and replacement procedures, can cause the life of the consumables to vary. You should change the tires if you notice an increase in multiple feeds, stoppages, or a decrease in feeder performance that is not resolved by following the cleaning procedures.

NOTES:

- Before replacing parts, disconnect the electrical power.
- Certain paper types (such as carbonless paper or newsprint), failure to clean regularly, and/or use of non-recommended cleaning solvents can shorten roller life.

Replacing the separation module and tires

1. Push the separation module up to snap it out and lift it out of position.

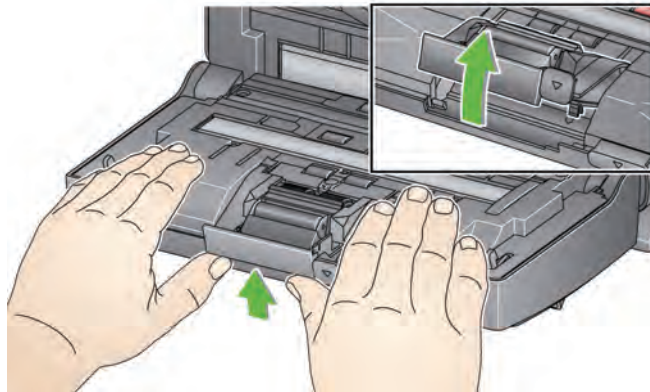

- If you are replacing the separation module, insert the new separation module by aligning the tabs with the slots and snapping it into position.

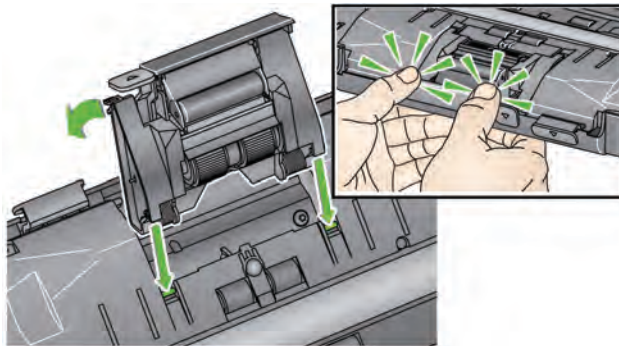

- If you are replacing the tires, continue with Step 2.

2. While holding onto the separation module, rotate the release lever back so you can access the separation roller.

CAUTION: Use caution as the release lever is spring-loaded and will snap back if you do not hold it in place.

3. Remove the separation roller from the separation module housing.

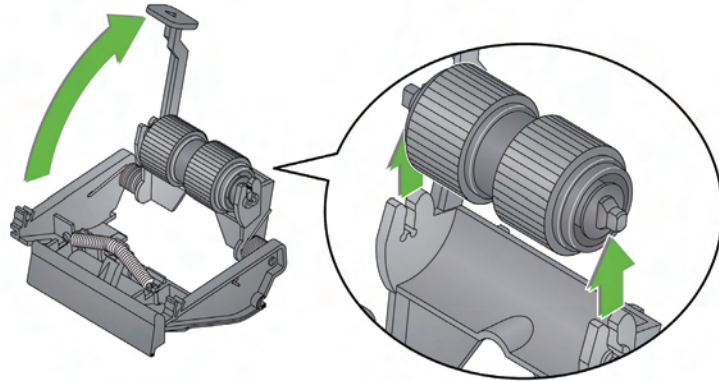

4. Remove each tire by sliding the tire off the core.
5. Install each new tire by gently pulling it over the core.
IMPORTANT: Do not overstretch the tire, it may tear.
6. Reinstall the separation roller in the separation roller housing. Be sure the separation roller snaps into place.
7. Reinstall the separation module by aligning the tabs with the slots and snapping it into position.

Replacing the pre-separation pad

1. Remove the separation module from the scanner by following the steps previously described in “Replacing the separation module and tires”.
2. Hold the separation module in both hands and locate the two side tabs which protrude slightly from the back of the separation module.
3. Push down on the side tabs until the pre-separation pad protrudes slightly from the front of the separation module.
4. Grasp the pre-separation pad and pull it out of the separation module.

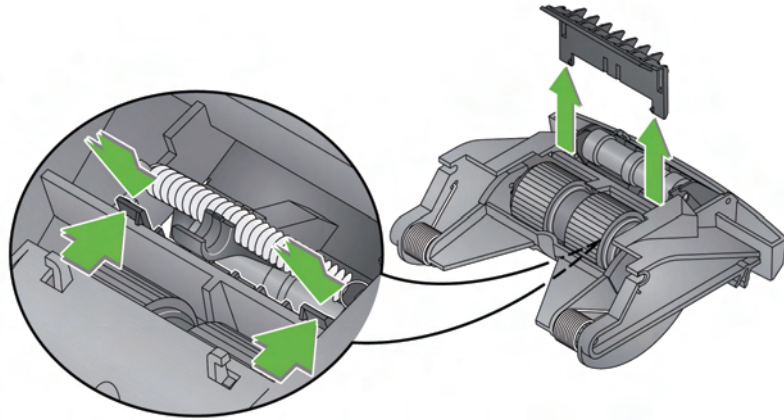

5. Discard the worn pre-separation pad.
6. Align the side tabs of a new pre-separation pad with the slots on the separation module.
7. Push the pre-separation pad firmly in the slots until the pre-separation pad flap rests lightly against the separation module tires.
8. Reinstall the separation module by aligning the tabs with the slots and snapping it into position.

Replacing the feed module and tires

NOTE: The paper present sensor is located to the right of the feed module. Be careful not to damage the paper present sensor when removing or cleaning around the feed module.

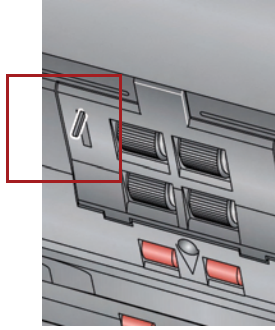

1. Lift the tab of the feed module cover and remove it from its position.

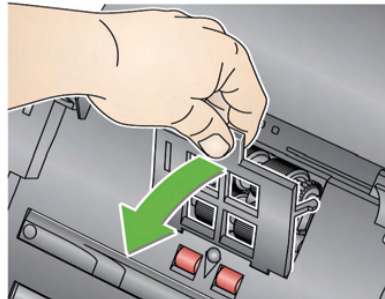

2. Rotate the feed module forward and push it to the left to lift it out of position.

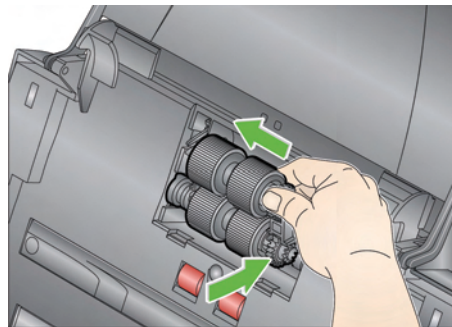

- If you are replacing the feed module, insert the new feed module by aligning the pins and pushing it toward the left to fit it into position. Be sure the gears are aligned and it snaps into place, then go to Step 8.
 - If you are replacing the tires, continue with Step 3.
3. Remove each core assembly by lifting up and out of position.

4. Remove each tire by sliding the tire off the core assembly.

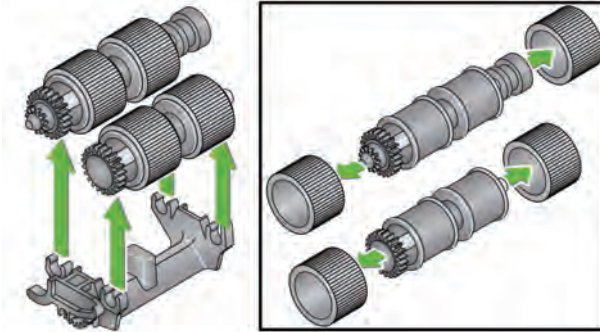

5. Install each new tire by gently pulling it over the core.

IMPORTANT: Do not overstretch the tire; it may tear.

6. Replace the core assembly in the feed module. You may need to slide the shaft to the right or left so the core fits properly within the feed module housing.

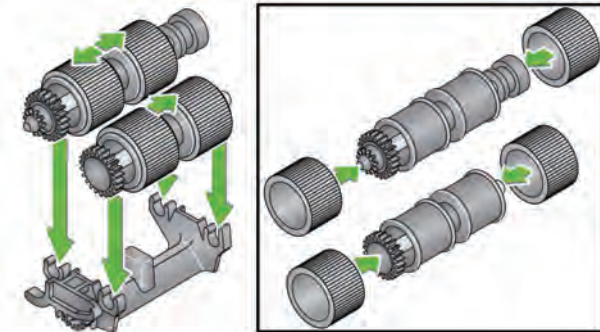

7. Reinstall the feed module.
8. Reinstall the feed module cover by aligning the tabs in the slots and pushing the feed module cover down until it snaps into place.

Adjusting the pre-separation roller tension

If you are experiencing multi-feeds or document jams, it may be necessary to adjust the pre-separation roller tension.

1. Remove the separation module from the scanner by following the steps described previously in “Replacing the separation module and tires”.
2. Locate the spring on the separation module.
3. Lift the spring from the holder and move it to the left or right as desired to adjust the tension.

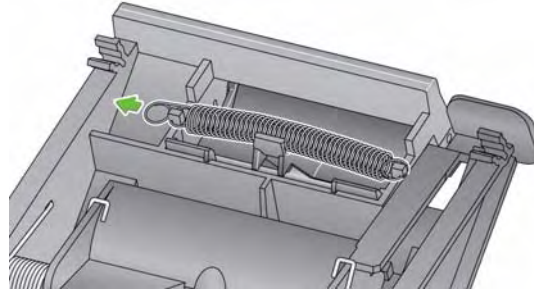

4. When finished, reinsert the separation module by aligning the tabs with the slots and snapping it into position.

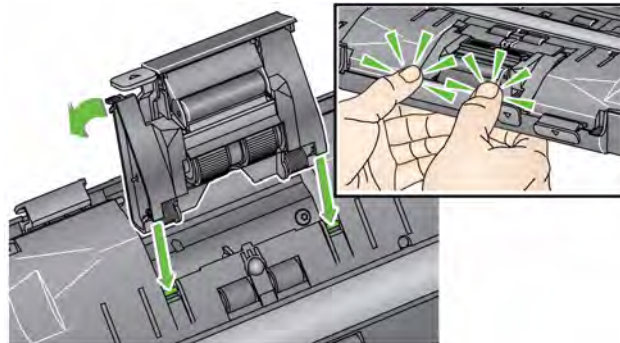

Supplies and consumables

Contact your scanner supplier to order supplies.

Description	CAT No.
<i>Kodak</i> Feed Rollers (qty 12)	148 4864
<i>Kodak</i> Separation Module	173 6115
<i>Kodak</i> Feed Module	826 9607
<i>Kodak Digital Science</i> Roller Cleaning Pads (qty 24)	853 5981
<i>Kodak Digital Science</i> Transport Cleaning Sheets (qty 50)	169 0783
Staticide Wipes for <i>Kodak</i> Scanners (qty 6 boxes of 24)	896 5519
<i>Brilliance</i> Detailer Wipes / for <i>Kodak</i> Scanners	826 6488
<i>Kodak</i> White Background Accessory	892 7717
<i>Kodak</i> A4 Flatbed Accessory	155 0268
<i>Kodak</i> Black Background Accessory for A4	863 6870

NOTE: Items and catalog numbers are subject to change.

5 Troubleshooting

Contents

Problem solving 5-1
LED codes 5-3
Indicator lights 5-3
Contacting Service 5-3

Problem solving

Occasionally you may encounter a situation with your scanner where it may not function properly. Use the chart below as a guide to check possible solutions to help you resolve the situation before calling Technical Support.

Problem	Possible Solution
Documents are jamming or multiple documents are feeding	<p>Make sure that:</p> <ul style="list-style-type: none">• the side guides are adjusted for the width of the documents you are scanning.• the output tray is adjusted for the length of the documents you are scanning.• all documents meet the specifications for size, weight and type as outlined in Appendix A, <i>Specifications</i>.• the scanner and tires are clean.• the spring on the pre-separation module is adjusted to the proper tension. See the procedures in Chapter 4, <i>Maintenance</i>.• the feed module and pre-separation module is installed properly and securely in place. See the procedures in Chapter 4, <i>Maintenance</i>. <p>To remove a document jam: <i>IMPORTANT: Be sure the input tray is up and the scanner is tilted before opening the cover. Do not pull the jammed document out of the scanner; open the scanner cover first.</i></p> <ul style="list-style-type: none">• Open the scanner cover.  <ul style="list-style-type: none">• Remove any jammed document(s) from inside the scanner.• Close the scanner cover and resume scanning.

Problem	Possible Solution
Scanner will not scan/feed documents	Make sure that: <ul style="list-style-type: none"> • the power cord is plugged securely into the back of scanner and the wall outlet. • the power supply, green LED is lit. • the power switch is on. • the wall outlet is not defective (call a licensed electrician). • the PC was restarted after installing the software. • document(s) is making contact with the feed rollers.
No images are being displayed	<ul style="list-style-type: none"> • If you are scanning one-sided documents, be sure the side you want to scan is facing the input tray (not facing you). For more information, see the section entitled, "Getting your documents ready to scan" in Chapter 3, <i>Scanning</i>.
Images are not being cropped correctly	<ul style="list-style-type: none"> • If the cropping options are enabled, Automatically Detect and Straighten or Automatically Detect and your images are not being cropped correctly, clean the imaging area. See the section entitled, "Cleaning the imaging area" in Chapter 4, <i>Maintenance</i>.
Roller marks appear on the document after scanning	Clean the rollers. See the procedures in Chapter 4, <i>Maintenance</i> .
Images have black background bleed-through	When scanning translucent documents, black bleed-through may be displayed on the image. To minimize this, adjust the Contrast value or select Draft (Fixed) in TWAIN or Fixed Processing in ISIS to improve the image or use the <i>Kodak White Background Accessory</i> .
Red, green or blue streaks are running through a color photo	The scanner is dirty and needs to be cleaned. Refer to the "Cleaning procedures" in Chapter 4, <i>Maintenance</i> .
Scanner is running slow	<ul style="list-style-type: none"> • Your PC may not meet the minimum requirements for the scanner. • The scanner is rated and designed to operate with USB 2.0, but will function in a USB 1.1 port. If you are using a USB 1.1 connection, update your connection to USB 2.0.
Unable to scan using Microsoft Office Document Imaging 2007 using the WIA driver	Select the scanner named: KODAK Scanner: i2000 from the Scanner drop-down list.

LED codes

Following is a list of the codes that may be displayed in the LCD display with a corresponding message.

NOTE: If you have a *Kodak i2400* Scanner, only the code will be displayed in the function window.

Codes	Message	Explanation/Action
0	Check USB cable	Indicates that there is no USB connection or the USB cable is not securely attached.
	Power saver mode	Indicates the scanner is in power saver mode. No action is required.
	Scanning...	The scanner is scanning documents.
U5, E3	Rescan documents	USB cable has been disconnected while the scanner was running.
U6	Clear paper path and close cover	Open the scanner cover and verify that all documents are removed from the paper path. Then close the scanner cover.
U8	Multifeed	<ul style="list-style-type: none">• A multifeed document has been detected. Clear the multifeed condition.• The document you are trying to scan is too long.
U9	Paper jam	Document jam or the paper path is blocked. Clear the documents from the paper path.
E1, E2		Turn power off and then on again. If the problem persists, call Service.
E2, E4, E7	Turn power off then on	Turn power off and then on again. If the problem persists, call Service.

Indicator lights

Steady green: the scanner is ready or scanning.

Flashing green: scanner initialization is in process.

Blinking green: scanner is in power saver mode.

Steady red: indicates a scanner error, such as the scanner cover is open. If the error is not user-correctable, you may need to power-cycle the scanner. If the problem persists, call Service.

Contacting Service

1. Visit www.Kodak.com/go/disupport to obtain the most current phone number for your country.
2. When calling, please have the following information ready:
 - A description of your problem.
 - The scanner model and serial number.
 - Computer configuration.
 - Software application you are using.

Appendix A Specifications

This appendix provides scanner specifications and system requirements.

Scanner Type/Speed (throughput speeds may vary depending on driver, application software, operating system and PC)	<p>Kodak i2400 Scanner — a duplex scanner which provides black and white, grayscale and color scanning up to 30 pages per minute/60 images per minute at 200 and 300 dpi.</p> <p>Kodak i2600 Scanner — a duplex scanner which provides black and white and grayscale up to 50 pages per minute/100 images per minute at 200 and 300 dpi; color scanning up to 40 pages per minute/80 images per minute at 200 dpi</p> <p>Kodak i2800 Scanner — a duplex scanner which provides black and white and grayscale scanning up to 70 pages per minute/140 images per minute at 200 and 300 dpi; color scanning up to 60 pages per minute/120 images per minute at 200 dpi.</p>
Scanning Technology	Dual CCD Grayscale output bit depth is 256 levels (8-bit) Color capture bit depth is 48 bits (16 x 3) Color output bit depth is 24 bits (8 x 3)
Optical Resolution	600 dpi
Output Resolutions	100, 150, 200, 240, 250, 300, 400, 600 and 1200 dpi
File Format Output	Single- and multi-page TIFF, JPEG, RTF, BMP, PDF and searchable PDF
Minimum Document Size	63.5 x 50 mm (2.5 x 2 in.)
Maximum Document Size	Scanner — 215 x 4064 mm (8.5 x 160 in.) Flatbed — 215 x 297 mm (8.5 x 11.69 in.)
Paper Weight	34 g/m ² to 413 g/m ² (9 to 110 lbs.) ID card thickness up to 1.25 mm (0.05 in.)
ADF Capacity	Handles small documents such as ID cards, embossed cards and insurance cards. i2400 Scanner — 50 sheets (20 lb./75 g/m ²) i2600 Scanner — 75 sheets (20 lb./75 g/m ²) i2800 Scanner — 100 sheets (20 lb./75 g/m ²)
Recommended Daily Volume	i2400: 2000 pages per day i2600: 4000 pages per day i2800: 6000 pages per day
Illumination	Dual LED
Multifeed Detection	Ultrasonic
Electrical requirements	100 - 240 V (international), 50/60 Hz
Scanner Dimensions	Height: 246 mm / 9.7 in. (not including input tray) Width: 330 mm / 13 in. Depth: 162 mm / 6.3 in. (not including input tray and output tray)
Scanner Weight	5.5 kg (12 lbs)
Host Connection	USB 2.0
Operating Temperature	10°C to 35°C (50 to 95°F)
Operating Humidity	15 to 76% RH
Environmental Factors	Energy Star qualified scanners

Power Consumption - Scanner	Off mode: <4 watts Running: <35 watts
Power Consumption - with A4 Flatbed	Off mode: ≤6 watts Running: <57 watts
Acoustic Noise (Sound Pressure level)	Operating: less than 58 dB(A) Off mode: less than 30 dB(A)
Bundled Software	TWAIN, ISIS, WIA Drivers, Smart Touch, PaperPort, OmniPage, Linux Sane and TWAIN Drivers available from: www.Kodak.com/go/scanners

System requirements

Following is the minimum recommended system configuration to run *Kodak i2400/i2600/i2800* Scanners.

- Recommended processor and memory:
 - For documents up to 660 mm (26 in.) long up to 400 dpi: Intel Core-2 Duo, 2.1 GHz per processor or equivalent, 2 GB RAM
 - For longer documents/higher resolutions: Intel Core-2, Duo, 2.1 GHz per processor or equivalent, 4 GB RAM

NOTE: For optimal performance when using a PC running Windows 7, at least 3 GB RAM is recommended.

- Supported operating systems:
 - Microsoft Windows XP (32-bit and 64-bit) with SP2 and higher
 - Microsoft Windows Vista with SP1
 - Microsoft Windows Vista x64 Edition
 - Microsoft Windows 7 (32-bit and 64-bit)
 - Microsoft Windows 2008 Server x64 Edition

Included Drivers: TWAIN, ISIS, WIA, Linux Sane

Appendix B Warranty - US and Canada only

Congratulations on the purchase of a *Kodak Scanner*. *Kodak Scanners* are designed to provide end users with the highest performance and reliability. All *Kodak Scanners* are covered by the following Limited Warranty.

Limited Warranty for *Kodak Scanners*

Eastman Kodak Company provides the following Limited Warranty on *Kodak Scanners* (excluding spare parts and consumables) distributed by Kodak or through Kodak's authorized distribution channels:

Kodak warrants that a *Kodak Scanner*, from the time of sale through the Limited Warranty period applicable to the Product, will be free of defects in materials or workmanship and will conform to the performance specifications applicable for the particular *Kodak Scanner*.

All *Kodak Scanners* are subject to the Warranty Exclusions described below. A *Kodak Scanner* found to be defective or which does not conform to the product specifications will be repaired or replaced with new or refurbished product at Kodak's option.

Purchasers may determine the applicable Limited Warranty period for the *Kodak Scanners* purchased by calling (800) 822-1414, or by visiting www.Kodak.com/go/disupport or by reviewing the Limited Warranty Summary Card enclosed with the *Kodak Scanner*.

Proof of purchase is required to demonstrate eligibility for warranty service.

Warranty exclusions

Kodak's Limited Warranty does not apply to a *Kodak Scanner* that has been subjected to physical damage after purchase, caused, for example, by casualty, accident, acts of God or transportation, including (a) by a failure to properly package and ship the Scanner back to Kodak for warranty service in accordance with Kodak's then current Packaging and Shipping Guidelines, including failure to replace the shipping restraint prior to shipping, or by a failure to remove the shipping restraint prior to use; (b) resulting from the user's installation, system integration, programming, re-installation of user operating systems or applications software, systems engineering, relocation, reconstruction of data, or removal of the product or any component (including breakage of a connector, cover, glass, pins, or seal); (c) from service, modification or repair not performed by Kodak or a service provider authorized by Kodak or by tampering, use of counterfeit or other non-Kodak components, assemblies, accessories, or modules; (d) by misuse, unreasonable handling or maintenance, mistreatment, operator error, failure to provide proper supervision or maintenance, including use of cleaning products or other accessories not approved by Kodak or use in contravention of recommended procedures or specifications; (e) by environmental conditions (such as excessive heat or other unsuitable physical operating environment), corrosion, staining, electrical work external to the product or failure to provide electro-static discharge (ESD) protection; (f) by failure to install firmware updates or releases available for the product and (g) by such other supplemental exclusions published from time to time online at www.Kodak.com/go/disupport or by calling (800) 822-1414.

Kodak provides no Limited Warranty for products purchased from countries other than the United States. Purchasers of products from foreign distribution channels must seek warranty coverage, if any, through the original source of purchase.

Kodak provides no Limited Warranty for products that are purchased as part of a third party manufacturer's product, computer system or other electronic device.

Any warranty for these products is provided by the OEM (Original Equipment Manufacturer) as part of that manufacturer's product or system.

The replacement product assumes the remainder of the Limited Warranty period applicable to the defective product or thirty (30) days, whichever is longer.

Installation Warning and Disclaimer

KODAK WILL NOT BE RESPONSIBLE FOR ANY CONSEQUENTIAL OR INCIDENTAL DAMAGES RESULTING FROM THE SALE, INSTALLATION, USE, SERVICING OR IMPROPER FUNCTIONING OF THIS PRODUCT, REGARDLESS OF THE CAUSE. SUCH DAMAGES FOR WHICH KODAK WILL NOT BE RESPONSIBLE, INCLUDE, BUT ARE NOT LIMITED TO, LOSS OF REVENUE OR PROFIT, LOSS OF DATA, DOWNTIME COSTS, LOSS OF USE OF THE PRODUCT, COST OF ANY SUBSTITUTE PRODUCT, FACILITIES OR SERVICES OR CLAIMS OF CUSTOMERS FOR SUCH DAMAGES.

If there is any conflict between other sections of this appendix and the Limited Warranty, the terms of the Limited Warranty prevail.

How to obtain Limited Warranty service

Kodak Scanners are supplied with information on unpacking, setup, installation and operation. Careful reading of the User's Guide will answer most of the technical questions the end user might have regarding proper installation, operation and maintenance of the product. However, should additional technical support be required, you may visit our website at: www.Kodak.com/go/disupport or contact:

Kodak's Response Center: **(800) 822-1414**

The Response Center is available Monday – Friday (excluding Kodak holidays) 8 a.m. to 5 p.m. EST.

Before placing the call, the eligible purchaser should have the *Kodak* Scanner model number, part number, serial number and proof of purchase available. The eligible purchaser should also be prepared to provide a description of the problem.

Response Center personnel will assist the end user in resolving the problem over the phone. The end user may be asked to run some simple, self-diagnostic tests and report the resulting status and error code messages. This will assist the Response Center in determining if the problem is the *Kodak* Scanner or another component and if the problem can be resolved over the phone. If the Response Center determines a hardware problem exists that is covered either under the Limited Warranty or a purchased Maintenance Agreement, a Return Material Authorization Number (RMA) will be assigned as needed, a service request will be initiated and repair or replacement procedures will follow.

Packaging and shipping guidelines

Purchaser must ship all warranty returns in a method that guarantees full protection of the product from shipping damage. Failure to do so will void the *Kodak* Scanner warranty. Kodak advises the purchaser to keep the original box and packing materials for storing or shipping. Kodak is not responsible for issues related to shipping damage. The purchaser must return only the *Kodak* Scanner. Prior to shipment, purchaser must remove and retain all "add-on" items, (i.e. adapters, cables, software, manuals, etc.). Kodak accepts no responsibility for these items and they will not be returned with the repaired or replacement *Kodak* Scanner. All products should be returned to Kodak in the original shipping container, or an authorized packaging box for the units being returned. Purchaser must install the shipping restraint before the *Kodak* Scanner is shipped. When the original packaging is not available, contact Kodak's Response Center at (800) 822-1414 for part numbers and replacement packaging ordering information.

Return procedure

Eligible purchasers seeking services for *Kodak* Scanners covered under this Limited Warranty must obtain a Return Material Authorization number ("RMA") by calling (800) 822-1414 and within ten (10) business days from the date of issuance of the RMA must return the *Kodak* Scanner to the address designated in the RMA at the end user's own expense and risk, in compliance with Kodak's current Packaging and Shipping Guidelines.

Any defective products or parts replaced by Kodak become the property of Kodak.

Customer responsibility

BY REQUESTING SERVICE, THE ELIGIBLE PURCHASER ACKNOWLEDGES THE TERMS OF THE LIMITED WARRANTY, INCLUDING THE DISCLAIMER AND LIMITATION OF LIABILITY PROVISIONS. PRIOR TO SEEKING SERVICE, THE END USER MUST BACK-UP ANY DATA OR FILES THAT MAY BECOME DAMAGED OR LOST. KODAK IS, WITHOUT LIMITATION, NOT RESPONSIBLE FOR LOST OR DAMAGED DATA OR FILES.

Warranty Service descriptions

Eastman Kodak Company (*Kodak*) offers a range of service programs to support its Limited Warranty and to assist with the use and care of the *Kodak* Scanner ("Service Methods"). A *Kodak* Scanner represents an important investment. *Kodak* Scanners provide the productivity needed to stay competitive. The sudden loss of this productivity, even temporarily, could seriously affect the ability to meet commitments. Downtime can be very expensive, not just in the cost of the repair but also in time lost. To help alleviate these problems, Kodak may use one of the service methods listed below, depending upon product type, in providing service under its Limited Warranty.

Included with selected *Kodak* Scanners is a Limited Warranty Registration card and a Limited Warranty Summary card. The Limited Warranty Summary card is specific by model. The Limited Warranty Summary card contains important warranty information, including the model number and the Limited Warranty. Refer to the Limited Warranty Summary card to determine the available Service Methods applicable to the particular *Kodak* Scanner.

If the Limited Warranty Registration card or Limited Warranty Summary card cannot be located, additional information may be obtained about the product, including updated warranty and service program information and restrictions, online at www.Kodak.com/go/disupport or by phone at (800) 822-1414.

To avoid service delays, Kodak urges end users to complete and return the enclosed Limited Warranty Registration Card at the first opportunity. If you cannot locate the Limited Warranty Registration card, you may register online at www.Kodak.com/go/disupport or by phone at (800) 822-1414.

Kodak also provides a variety of service programs that may be purchased to assist with the use and care of the *Kodak* Scanner. Kodak is committed to providing its customers with quality, performance, reliability and service under the Limited Warranty.

On-site service

For the selected *Kodak* Scanner, and after the Response Center verifies a hardware problem, a service call will be opened and logged. An *Kodak* Field Engineer will be dispatched to the product location to perform repair service if the product is located within the contiguous forty-eight (48) United States, in certain areas of Alaska and Hawaii, and if there are no security, safety or physical requirements that would restrict the Field Engineer's access to the scanner. For additional information on service areas, visit our website at: www.Kodak.com/go/docimaging. On-Site Service will be provided between the hours of 8 a.m. and 5 p.m. local time, Monday through Friday (excluding *Kodak* holidays).

AUR

AUR may be one of the easiest and most comprehensive service offerings in the industry. In the unlikely event of a product defect, for eligible purchasers of certain *Kodak* Scanners, *Kodak* will replace that product within two business days.

The AUR provides advance replacement on specific failed or broken *Kodak* Scanner. To be eligible to take advantage of the AUR, the eligible purchaser must obtain an RMA number, sign an Advance Replacement Agreement and provide a credit card deposit to secure the replacement product. The RMA number should be kept in the event that the status of the replacement product needs to be checked. The eligible purchaser will be asked for the address where the replacement product is to be shipped. The eligible purchaser will also be faxed packing and shipping instructions for the malfunctioning product. The eligible purchaser will then receive a replacement product within 2 business days after the service call initiation and *Kodak*'s receipt of the signed agreement. The malfunctioning product must be received by *Kodak* within ten (10) days of the end user's receipt of the replacement product or the end user's credit card will be charged the list price of the replacement product. Shipment of replacement Imaging Product will be made at *Kodak*'s expense and choice of freight carrier. Shipments not made under *Kodak*'s directions and choice of freight carrier may void the Limited Warranty.

Before the product is returned to *Kodak*, be sure to remove all options and accessories (which include power cord, documentation, etc.) that are not covered by the Limited Warranty. The box and packaging in which the replacement product was shipped must be used to return the malfunctioning product. If the malfunctioning product is not returned in the box and packaging in which the replacement product was shipped the Limited Warranty may be voided. The Return Material Authorization Number ("RMA") must be clearly marked on the outside of the box to ensure proper receipt and credit of the defective product.

Depot service

If the *Kodak* Scanner is not eligible for Advance Exchange or On-Site Service, an eligible purchaser may utilize our Depot Repair Service. The eligible purchaser will be instructed to ship the product to the nearest authorized Depot Repair Center. Product must be shipped at the eligible purchaser's risk and expense to the repair center. Before the product is returned to the repair center, be sure to remove all options and accessories (which include power cord, documentation, etc.) not covered by the Limited Warranty. All products should be returned to *Kodak* in the original shipping container, or in a recommended packing box. The *Kodak* Scanner must have the shipping restraint installed before it is shipped. When the original packaging is not available, contact *Kodak*'s Response Center at (800) 822-1414, for ordering information. Eligible purchasers seeking services for *Kodak* Scanners must obtain a Return Material Authorization number ("RMA") by calling (800) 822-1414, and within ten (10) business days from the date of issuance of the RMA must return the *Kodak* Scanner to the address designated in the RMA at the end user's own expense and risk. The Return Material Authorization Number ("RMA") must be clearly marked on the outside of the box to ensure proper receipt and credit of the defective product.

Upon receipt of the product, the repair center will repair product within ten (10) business days. The repaired product will be shipped back two-day express mail at no expense to the eligible purchaser.

Important restrictions

Eligibility: The Advance Exchange Program and the Depot Service are available to eligible purchasers in the fifty (50) United States, and On-Site Service is available in the contiguous forty-eight (48) states and in certain areas of Alaska and Hawaii for products purchased from authorized distributors of *Kodak*. The *Kodak* Scanner will be ineligible for any service under warranty if the product falls under any of *Kodak*'s then-current Warranty Exclusions, including a purchaser's failure to return defective products to *Kodak* in compliance with *Kodak*'s then current Packaging and Shipping Guidelines. Persons are only considered "eligible purchasers" or "end users" if they originally purchased the *Kodak* Scanner for their own personal or business use, and not for resale.

Consumables: Consumables are items that wear out under normal use and must be replaced by the end user as needed. Consumables, supplies, other expendable items and those items identified as being the user's responsibility in the User's Guide are not covered under the Limited Warranty.

If any of the above excluded parts or services are required, they may be available through an authorized service provider at their hourly rates and at terms then in effect.

Any defective products or parts replaced by *Kodak* become the property of *Kodak*.

Contacting Kodak

For Information on *Kodak* Scanners:

Website: www.Kodak.com/go/docimaging

For U.S. Service, Repair and Technical Assistance by Telephone:

Telephone technical support is available Monday-Friday between the hours of 5 a.m. to 5 p.m. excluding Kodak holidays.

Phone: (800) 822-1414

For Technical Documentation and FAQ's available 24 hours a day:

Website: www.Kodak.com/go/docimaging

For Service Program Information

Website: www.Kodak.com

Phone: (800) 822-1414

Kodak