

**Power-Sure 700**

# Instruction Manual

Effective September 2013  
New information



**EATON**

*Powering Business Worldwide*

## **DISCLAIMER OF WARRANTIES AND LIMITATION OF LIABILITY**

The information, recommendations, descriptions and safety notations in this document are based on Eaton Corporation's ("Eaton") experience and judgment and may not cover all contingencies. If further information is required, an Eaton sales office should be consulted. Sale of the product shown in this literature is subject to the terms and conditions outlined in appropriate Eaton selling policies or other contractual agreement between Eaton and the purchaser.

THERE ARE NO UNDERSTANDINGS, AGREEMENTS, WARRANTIES, EXPRESSED OR IMPLIED, INCLUDING WARRANTIES OF FITNESS FOR A PARTICULAR PURPOSE OR MERCHANTABILITY, OTHER THAN THOSE SPECIFICALLY SET OUT IN ANY EXISTING CONTRACT BETWEEN THE PARTIES. ANY SUCH CONTRACT STATES THE ENTIRE OBLIGATION OF EATON. THE CONTENTS OF THIS DOCUMENT SHALL NOT BECOME PART OF OR MODIFY ANY CONTRACT BETWEEN THE PARTIES.

In no event will Eaton be responsible to the purchaser or user in contract, in tort (including negligence), strict liability or otherwise for any special, indirect, incidental or consequential damage or loss whatsoever, including but not limited to damage or loss of use of equipment, plant or power system, cost of capital, loss of power, additional expenses in the use of existing power facilities, or claims against the purchaser or user by its customers resulting from the use of the information, recommendations and descriptions contained herein. The information contained in this manual is subject to change without notice.

## Contents

General description . . . . .	<b>1</b>	Startup sequence . . . . .	<b>7</b>
Monitor . . . . .	<b>1</b>	Preventive maintenance . . . . .	<b>7</b>
Protection . . . . .	<b>1</b>	General troubleshooting guide . . . . .	<b>7</b>
Operation . . . . .	<b>2</b>	Troubleshooting . . . . .	<b>7</b>
Benefits of owning and using the Power-Sure 700 . . . . .	<b>2</b>	Equipment required . . . . .	<b>8</b>
Specifications . . . . .	<b>2</b>	Power modules (SCRs) . . . . .	<b>8</b>
Main transformer . . . . .	<b>3</b>	Check the SCR snubber card . . . . .	<b>9</b>
Cabinet . . . . .	<b>3</b>	Check control card and filter card . . . . .	<b>9</b>
Input breaker . . . . .	<b>3</b>	Final testing and adjustment . . . . .	<b>10</b>
Industry standards . . . . .	<b>3</b>	Control board adjustments (#49120/407415) field adjustment procedure . . . . .	<b>22</b>
Theory of operation . . . . .	<b>3</b>	Adjustment procedure . . . . .	<b>22</b>
Sizing the Power-Sure 700 . . . . .	<b>4</b>	Parts kits . . . . .	<b>22</b>
Installation considerations . . . . .	<b>4</b>	Replacement parts . . . . .	<b>22</b>
Inspection and installation . . . . .	<b>5</b>	Technical diagrams . . . . .	<b>23</b>
Unpacking . . . . .	<b>5</b>	Cabinet dimensions . . . . .	<b>36</b>
Storing . . . . .	<b>5</b>	Manual bypass switch . . . . .	<b>36</b>
Choice of location . . . . .	<b>5</b>	Normal mode . . . . .	<b>36</b>
Inspection . . . . .	<b>5</b>	Bypass mode . . . . .	<b>36</b>
Installation procedure . . . . .	<b>5</b>	Metering option . . . . .	<b>37</b>
Input wire size, grounding, and output wiring . . . . .	<b>5</b>	Warranty . . . . .	<b>37</b>





---

**IMPORTANT**

---

Save these instructions. Please read this manual before using equipment.

## General description

The Power-Sure™ 700 is a continuous duty electronic voltage regulator designed to supply reliable, clean regulated power to critical loads. An efficient design with state-of-the-art microprocessor controlled solid-state devices provide immunity to all line disturbances.

The basic design consists of a three-phase triple-shielded isolation transformer with seven separate voltage taps per phase. Output regulation is achieved by monitoring the input and automatically switching taps anytime the input line sags or surges. The special process of triple-shielded isolation transformers provide superior common mode and transverse mode noise attenuation. Automatic switching occurs during current zero, allowing noise-free switches for both leading and lagging power factor loads that are connected to the Power-Sure 700.

## Monitor

Monitoring of the Power-Sure 700 is simple, clean, and effective. Three green light indicators are utilized to display "POWER ON" (output line to neutral for each phase) and one red light indicator to display "ALERT." The "POWER ON" display is connected directly to the output that indicates the Power-Sure 700 is operating properly with just a quick glance. The "ALERT" display represents an overtemp problem when illuminated, and will shut down the output, but cooling fans remain on. Overtemp thermal sensors are strategically located at critical points on the regulator assemblies and transformer. The main AC input circuit breaker must be turned off in order to reset the "ALERT" light.

## Protection

Protection is accomplished very effectively to minimize failures and the cost of repairs. A total of four major devices protect the Power-Sure 700.

1. The input is protected with an integrally mounted AC circuit breaker for abnormal current overloads and provides a convenient means of disconnecting utility power.
2. The electronic regulating devices are protected with fast-acting semi-conductor fuses. These fuses are designed to clear before damage occurs to the more expensive SCR regulating devices. The main transformer is protected by fuse links connecting the SCR regulators together, and are designed to clear in the event that two or more SCRs should fail. This will prevent a transformer tap short and the possibility of transformer failure.
3. Overtemp sensing devices are mounted at critical points on the SCR regulating assembly and the main transformer. When an overtemp condition exists, the "ALERT" light will illuminate and hold until the overtemp is corrected. There are no automatic shutoff circuits for the "ALERT" condition. The main AC input breaker must be turned off in order to reset the "ALERT" light.
4. Optional dedicated surge protective device can be installed internally if requested at time of order. This surge suppression device (SPD) is a CVX 50 kA SPD for Power-Sure 700 units 50 kVA and below, and CVX 100 kA SPD for Power-Sure 700 units 75 kVA and above. This unit provides effective transient voltage surge suppression and will help to prolong the life of the Power-Sure 700.

## Operation

### Operation

The Power-Sure 700 is operated by simply turning on the main AC input circuit breaker. All units 50 kVA and larger are equipped with a bypass switch as a standard feature. For units 45 kVA and smaller, the bypass switch is optional. This is a no load switch and MUST only be operated when the unit is OFF. The bypass switch should be in the "NORMAL" position unless a problem occurs with the system. If a problem occurs, turn OFF the main AC circuit breaker and turn the bypass switch to the "BYPASS" position. Re-energize the system by turning on the AC circuit breaker and contact the Customer Support Department for repairs.

Any "ALERT" condition requires the main AC input breaker to be turned off in order to reset the "ALERT" light.

**FOR ASSISTANCE, CALL 1-800-809-2772, option 4, then option 2.**

### Benefits of owning and using the Power-Sure 700

- Line harmonic filtering
- Small physical size
- Simple and inexpensive installation
- Highly efficient
- Quiet operation
- Low BTU output
- Low failure rate
- Seven-tap, microprocessor control and diagnostics
- UL® Listed to 1012 standards
- Priced to be affordable
- Conservatively rated
- Extremely high surge capability
- Simple operation
- Input electronic circuit breakers
- Nationwide customer support service

### Specifications

- Dynamic electrical specifications
- Output: maintained to within  $\pm 3\%$  of nominal ①
- Input:  $+10\%$  to  $-23\%$  of the nominal rated input ①
- Frequency: 60 Hz  $\pm 3$  Hz ①
- Input power factor:  $>0.99$  PF with resistive load
- Line regulation: output is  $\pm 3\%$  of nominal for input variations of  $+10\%$  to  $-23\%$  of nominal

- Load regulation: output maintained within 3% from no load to full load
- Response time:  $<1/2$  cycle
- Correction time: output will correct to within  $\pm 3\%$  of nominal in 1.5 cycles or less
- Harmonic distortion: Less than 1.0% THD added to the output waveform under any dynamic linear loading conditions presented to the line regulator
- Transverse-mode noise attenuation: 3 dB down at 1000 Hz, 40 dB/decade to below 50 dB with resistive load
- Common-mode noise attenuation: 146 dB
- Audible noise: 45 dB or less
- Turn on characteristics: when energized, voltage overshoot will be less than 5% of nominal for 1 cycle or less
- Overload rating: 1000% for 1 cycle and 200% for 10 seconds
- Ambient rating:  $-10^\circ$  to  $+40^\circ$  Celsius
- Integral manual rotary maintenance bypass switch standard on 50 to 500 kVA units and optional on smaller units

**Note:** 50 Hz models available.

**Figure 1. Regulation Graphs**

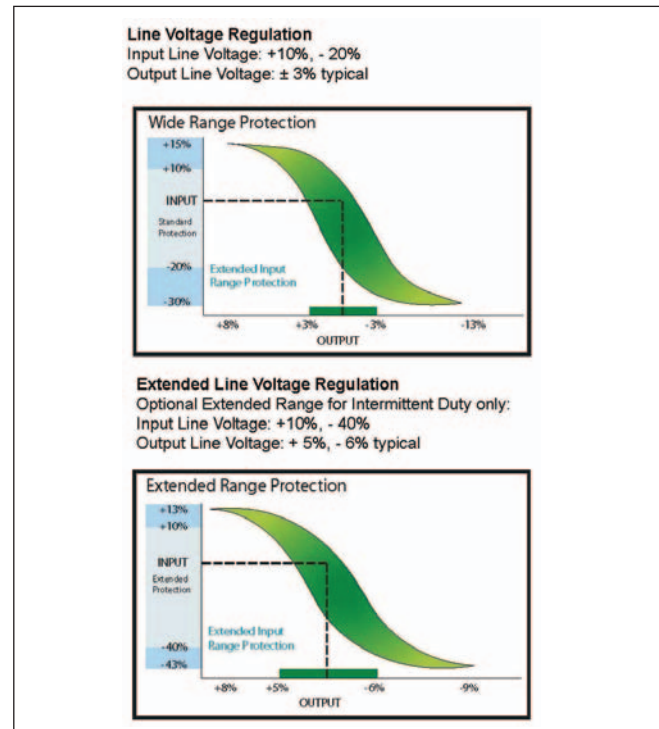

① Optional extended input regulation range provided on some units. If provided, reference the description next to the units specification tag.

## Main transformer

- Windings: all copper
- Magnetics: grain orientated, M6 grade, stress-relieved transformer steel is utilized for minimum losses and maximum efficiency
- Insulation: Class (N) 200 all sizes
- Shielding: multiple triple copper shield to minimize interwinding capacitance, transient, and noise coupling between primary and secondary windings
- Cooling: convection, operating temp is 130 degrees Celsius maximum rise above ambient
- Isolation: output is fully isolated from input

## Cabinet

Heavy-gauge industrial steel throughout. Metal is anti-corrosive phosphate treated prior to paint. Paint is a baked finish.

## Input breaker

Main input molded-case circuit breaker, rated at 125% of full load input current.

## Industry standards

Listed to UL 1012, standard for "power units other than Class 2."

## Theory of operation

The Power-Sure 700 provides the triple function of isolation, noise attenuation and voltage regulation. The first two functions are provided by the power transformer, where as the third function of voltage regulation is achieved through solid-state thyristors (SCRs) connected to taps on the power transformer. A microprocessor monitors and controls the overall function of regulating the system.

The power transformer is manufactured with a unique method of shielding which produces very low capacitive coupling between the primary and secondary. This low coupling provides excellent attenuation of the common-mode noise. In addition, special care is taken in the design of the transformer to attenuate transverse-mode noise above 1000 Hz.

The power transformer has taps to which solid-state switches (SCRs) are connected.

The voltage regulator incorporated in the Power-Sure 700 is microprocessor controlled to achieve optimum correction time of input voltage sags and surges. The response time is typically one half (1/2) cycle for 100% correction, therefore, a very smooth switch takes place undetected by computer equipment.

As the input voltage (building power) varies, the voltage available at each tap of the transformer will also change. The amount of variation is dependent upon the input sag or surge, turns ratio, and transformer losses.

By selecting a particular tap voltage, the output can be kept within a tight range. The way in which this is accomplished is that an electronic control card using a microprocessor continually monitors the input voltage. When a voltage fluctuation occurs, which exceeds the limit of rated regulation (typically  $\pm 3\%$ ), the output is switched to another tap, that is within the required range. This "switch" will be made at the next current zero crossing to allow for both leading and lagging power loads to be connected to the conditioner.

# Sizing the Power-Sure 700

**Table 1. Eaton Power-Sure 700 Ordering Guidelines**

Nominal Input Voltage		kVA Ratings and Dimensions						Options ①	
Delta Input: L, L, L, G		kVA	Weight (lbs)	BTUs/ hr	Bypass	Metering	Cabinet Size Dimensions H x W x D in Inches (mm)		Blank = No options B = Bypass switch ② M1 = Standard metering (IQ 130) M2 = Premium metering (IQ 150) S = Surge
B = 208	C = 240	010	440	1,025	Optional	No	30.20 x 22.20 x 29.00 (767.1 x 563.9 x 736.6)		
H = 400	D = 480	010	520	1,205	Optional	Yes	44.20 x 22.20 x 29.00 (1122.7 x 563.9 x 736.6)		
E = 600		015	465	1,540	Optional	No	30.20 x 22.20 x 29.00 (767.1 x 563.9 x 736.6)		
		015	700	1,540	Optional	Yes	44.20 x 22.20 x 29.00 (1122.7 x 563.9 x 736.6)		
		025	700	2,560	Optional	Yes	44.20 x 22.20 x 29.00 (1122.7 x 563.9 x 736.6)		
		030	720	3,090	Optional	Yes	44.20 x 22.20 x 29.00 (1122.7 x 563.9 x 736.6)		
		045	950	4,600	Optional	Yes	44.30 x 45.90 x 29.00 (1125.2 x 1165.9 x 736.6)		
		050	1,176	7,332	Yes	Yes	66.00 x 29.00 x 35.50 (1676.4 x 736.6 x 901.7)		
		075	1,575	9,514	Yes	Yes	76.00 x 34.40 x 35.50 (1930.4 x 873.8 x 901.7)		
		100	2,014	11,833	Yes	Yes	76.00 x 34.40 x 35.50 (1930.4 x 873.8 x 901.7)		
		125	2,137	14,748	Yes	Yes	76.00 x 34.40 x 35.50 (1930.4 x 873.8 x 901.7)		
		150	2,240	17,698	Yes	Yes	76.00 x 34.40 x 35.50 (1930.4 x 873.8 x 901.7)		
		225	3,300	23,000	Yes	Yes	77.40 x 56.00 x 41.50 (1966.0 x 1422.4 x 1054.1)		
		300	4,000	30,750	Yes	Yes	77.40 x 56.00 x 41.50 (1966.0 x 1422.4 x 1054.1)		
		500	5,500	51,250	Yes	Yes	77.00 x 72.40 x 48.40 (1955.8 x 1839.0 x 1229.4)		

① Units with no surge protection option, bypass option or metering will have blanks in the last three spaces in the catalog number.

② Bypass is standard on 50 kVA and larger units and an option on 45 kVA and smaller units.

### Notes

Listings—UL Listed, CSA Certified, except for 600V: no UL, CSA on 600V units.

For output distribution, call factory.

K factor rated units available on request.

## Sizing the Power-Sure 700

When sizing the Power-Sure 700, be sure to take into consideration all loads and circuits the unit is to supply. A good way to ensure that the Power-Sure 700 is sized properly is to use the following guidelines:

- List each piece of equipment, include model, voltage, current, and kVA
- Calculate kVA of load plus a safety margin
- When this is not possible, gather the data by reading the specification plate of the equipment you plan on backing up
- One method is to ask the vendor of the equipment to supply you with the information you need
- Be sure to verify the input supply voltage and the output requirements of the Power-Sure 700

## Installation considerations

Prior to installing the Power-Sure 700, be sure to take into consideration the site you have selected. Power Conditioners produce heat and therefore require ventilation, as well as accessibility.

Consider these factors:

- Ventilation
- Size of the Power-Sure 700
- Weight load
- Audible noise requirements
- Monitors
- Options
- Clean environment
- Proper ground techniques
- Input source voltage
- Receiving facilities
- Distribution of power
- Room temperature
- Clearances
- Accessibility
- Excessively long power runs



## Inspection and installation

---

### WARNING

---

**There are dangerously high voltages present within the enclosure of the power supply system. Under no circumstances should any person reach within the enclosure of this equipment. All service to this piece of equipment should be performed by qualified personnel only.**

## Unpacking

Upon receipt of the unit, visually inspect for shipping damage. If any damage is found, the Purchaser must contact the Carrier immediately and file a shipping damage claim.

**Note:** Be sure to remove top and side panels and inspect inside unit for shipping damage.

Eaton should be notified if the nature of damage is such that operation of the equipment has been impaired. Please call 1-800-809-2772, option 4, then option 2.

## Storing

If it is necessary to store the unit for a period of time before it is installed, be sure to place the unit in a clean, dry area. To prevent excessive dust from accumulating on the unit, it is advisable to protect it by replacing it in the original container. The unit must be handled at all times with the same care you would give to any piece of precision industrial equipment.

## Choice of location

The unit has been completely inspected and extensively tested under various load conditions prior to shipment. Care to install it at a proper location will ensure long trouble-free operation.

The unit is air cooled with the air intake at the bottom and exhausts at the top, front or at the sides. Therefore, it should be installed in a clean, dry place with enough clearance to allow a free flow of air. Allow at least 4.00 inches (101.6 mm) of space between the unit and the wall or other equipment. Allow enough space for maintenance on all four sides of larger units.

## Inspection

- A. Remove top and side panels (not applicable on 225 kVA and larger).
- B. Check all electrical connections to be sure none have loosened during shipment. Tighten if necessary. Check for any internal damage.
- C. Check the spec. plate on the front of the unit to be sure that the voltage and frequency match the available power supply. Under no circumstances should the unit be connected to a power source which does not conform to the spec. plate rating.

## Installation procedure

- A. Verify that the input voltage to the unit matches the unit's specification plate.
- B. Refer to installation diagrams on **page 27–page 35** for input and output connection recommendations and conduit locations.

## Input wire size, grounding, and output wiring

- A. Conduit should be used for both input and output wiring.
- B. Minimum ground wire size is based on 2011 National Electrical Code® Table 250.122.
- C. Input wire size is based on 2011 NEC® Table 310.15(B)(16) specifying not more than three conductors in a raceway based on ambient of 30 degrees Celsius, and wire rated at 75 degrees Celsius.
- D. Output neutral to ground is already bonded during manufacturing of the Power-Sure 700.
- E. Output requires four (five including ground wire) conductors in a raceway assuming neutral as a current carrying conductor. This requires conductors to be derated by using a multiplier of .8, reference 2011 NEC Article 310.15(B)(3)(a).

## Example

1. Assume #10 wire maximum current = 25A.
2. Multiply  $25 \times .8 = 20$ .
3. 20A is maximum current for #10 wire in a raceway with four conductors.

**Note:** Installation is subject to local codes—verify with a local electrical inspector.

## Input wire size, grounding, and output wiring

**Table 3. Wire Size Chart**

Unit Size in kVA	Input Breaker Size (Amperes)	Input Wire Size	Minimum Ground Wire Size
<b>208 Vac Input</b>			
10	40	#8	#10
15	60	#6	#10
25	110	#2	#6
30	110	#2	#6
45	175	2/0	#6
50	200	3/0	#6
75	300	#350	#4
100	400	3/0 ①	#3
125	500	250 kcmil ①	#2
150	600	350 kcmil ①	#1
225	800	500 kcmil ①	1/0
300	1200	500 kcmil ②	3/0
500	2000	500 kcmil ④	250 kcmil
<b>240 Vac Input</b>			
10	30	#10	#10
15	50	#8	#10
25	100	#3	#8
30	100	#3	#8
45	150	1/0	#6
50	175	2/0	#6
75	250	#250	#4
100	350	500	#3
125	400	3/0 ①	#3
150	500	250 kcmil ①	#2
225	800	500 kcmil ①	1/0
300	1000	500 kcmil ②	2/0
500	1600	500 kcmil ③	4/0

① 2 pcs.

② 3 pcs.

③ 4 pcs.

④ 5 pcs.

**Note:** Refer to NEC for output wire size based on output breaker size as mentioned in Step E on the previous page.

Unit Size in kVA	Input Breaker Size (Amperes)	Input Wire Size	Minimum Ground Wire Size
<b>480 Vac Input</b>			
10	15	#10	#14
15	25	#10	#10
25	50	#6	#10
30	50	#6	#10
45	80	#4	#8
50	80	#4	#8
75	125	#1	#6
100	175	2/0	#6
125	200	3/0	#6
150	250	250 kcmil	#4
225	350	500 kcmil	#3
300	500	250 kcmil ①	#2
500	800	500 kcmil ①	1/0
<b>600 Vac Input</b>			
10	15	#10	#14
15	20	#10	#12
25	40	#8	#10
30	40	#8	#10
45	60	#6	#10
50	70	#4	#8
75	100	#3	#8
100	150	1/0	#6
125	175	2/0	#6
150	200	3/0	#6
225	300	350 kcmil	#4
300	400	500 kcmil	#3
500	700	400 kcmil ①	1/0

## Startup sequence

### WARNING

**There are dangerously high voltages present within the enclosure of the power supply system. Caution must be taken when working with the enclosure. It is recommended that all work be performed by qualified electrical personnel only.**

**Note:** Initial startup should be performed with no-load on system.

1. Re-install all panels that may have been removed during installation.
2. Make sure the input circuit breaker is in the OFF position.
3. Energize the primary building power.
4. Turn on the main AC input breaker.
5. Verify that the output voltage is within the specified range.
6. Verify output phase rotation is correct.
7. Turn the system off.
8. Connect the loads one at a time and repeat Step 5.

## Preventive maintenance

### WARNING

**Danger of electrical shock. Turn off all power supplying this equipment prior to maintenance.**

To ensure longer component life and trouble-free operation, minor preventive maintenance procedures should be performed at regular intervals, for example once every year. More frequent inspection intervals would be needed for more severe operating conditions and larger number of hours of continuous operation.

- A. Remove top and side panels and at each service inspection any accumulated dust, dirt or foreign particles should be carefully removed. Special care should be exercised in cleaning the thyristors, heat sinks, and the control assembly.
- B. **Inverse parallel silicon rectifiers (SCRs) or thyristors:** The silicon controlled rectifiers (SCRs) usually fail in the shorted mode. When this happens, normally the fusible link in series with the SCR will be blown open to clear the short and prevent damage to the transformers. The individual SCR can be checked with an ohmmeter. Refer to **page 8** for resistance checking procedures.
- C. Replace top and side panels. Turn unit on with no load.
- D. Turn on loads.
- E. Check to verify all fans are operational.

**Note:** Preventive maintenance plans are included on **page 38** of the manual.

## General troubleshooting guide

**Table 4. General Troubleshooting Guide**

Symptom	Probable Causes
1. No output on one or more phases	A. Blown fuse B. Defective SCR or power module C. Defective control card D. Defective sense card E. No input
2. Output is too high or too low	A. Control card adjustment B. Defective control card C. Defective sense card D. Defective SCR or power module E. Input out of range
3. Input breaker tripping off	A. Defective breaker B. System overloaded C. Over/undervoltage detection is shutting down system (see symptom #2) D. Defective over/under detection card E. Shorted taps
4. Blowing semi-conductor fuses	A. Shorted SCRs or power modules B. Output loads shorted
5. No output voltage	A. Defective over/under output detection PCB

### WARNING

**There are dangerously high voltages present within the enclosure of the power supply system. Under no circumstances should any person reach within the enclosure of this equipment. All service to this piece of equipment should be performed by qualified personnel only.**

## Troubleshooting

**Note:** Circuit diagrams in this manual are for reference only. Always refer to the actual circuit diagrams received with the system.

### Introduction

This procedure is written in a specific order and must be used from start to finish when troubleshooting. Any steps skipped over may cause serious damage to the system.

## Equipment required

## Equipment required

True rms digital multimeter, SCR tester, common hand tools.

### Step 1: Disassembling the power line conditioner

- A. Turn off the power to the conditioner at its source.
- B. Turn off the input circuit breaker on the unit and the output circuit breakers to all loads (remove all loads from unit).
- C. Remove the top and side covers to the conditioner.

### Step 2: Electrical connections, fuses

Refer to diagrams on **page 11–page 16** for component locations.

- A. Inspect the unit for proper tightness of all electrical connections, burnt, frayed, broken, or loose connections and components in these areas.

Input and output connections, SCR assembly, SCR snubber, output filter assembly, MOVs (metal oxide varistors), circuit boards, bypass switch, and transformer connections.

- B. Correct and tighten any loose connections, replace any physically burned or broken components.
- C. Check all fuses in system.

**Note:** Remove fuses from circuit when checking to avoid false readings.

- D. Time delay fuses, semi-conductor fuses, fan fuses, circuit board fuses, SCR fusible Link wire.

## Power modules (SCRs)

Refer to diagram on **page 17** for 10–30 kVA SCR assembly, **page 18** for 45–150 kVA SCR assembly, **page 19** for 225–300 kVA SCR assembly, and **page 20** for 500 kVA SCR assembly.

1. Unplug the connections to the control cards Part # 49120/407415 labeled TB1, TB2, and TB3.
2. Disconnect any cooling fans in the unit so your SCR resistance checks are not interfered by fan motor coils. Also, remove main semi-conductor fuse located on all three SCR assemblies and any wires attached to the fuse. Each power module contains two inverse parallel SCRs.

**Figure 2. Power Module**

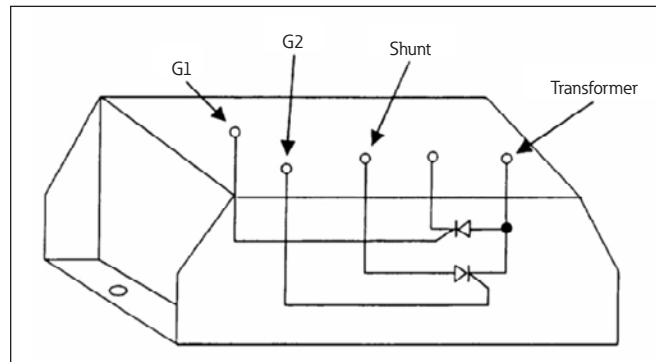

3. Measure the following resistance on each power module. There are seven per phase or 21 for all three phases. Refer to the circuit diagrams received with your unit.

**Note:** When checking the power module assembly, if more than one defective power module is present it will appear as if all the power modules are defective. If this is the case, the individual power module must be isolated from the power transformer.

- a. K1-1 to K2-1 through K1-7 to K2-7 = High resistance, 1 megohm.
  - b. K1-1 to G1-1 through K1-7 to G1-7 = 10 to 90 ohms.
  - c. K1-1 to G2-1 through K1-7 to G2-7 = 1 megohm.
  - d. K2-1 to G2-2 through K2-7 to G2-7 = 10 to 90 ohms.
  - e. K2-1 to G1-1 through K2-7 to G1-7 = 1 megohm.
  - f. G1-1 to G2-1 through G1-7 to G2-7 = 1 megohm.
4. Replace any defective power modules. This may require removing the shunt and loosening the K1 bus from all the power modules to get the defective power module out. Use only equivalent hardware and heat sink grease when replacing power modules.
  5. If a resistance measure is questionable, a more thorough test will ensure an SCR is good or bad by using the following test procedure.
    - a. Completely isolate SCR under test by removing all connections to the device.
    - b. Hook up the following test circuit to each individual SCR.
    - c. Plug in SCR tester. With switch #1 open light bulb should be off. If not, replace SCR.
    - d. Close switch #1. Light bulb should illuminate to about 3/4 brilliance. If not, replace SCR. See **Figure 3**.

Figure 3. SCR Tester

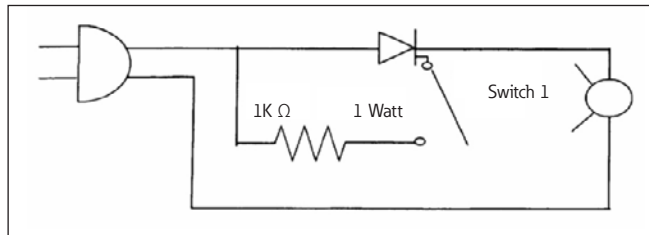

6. Re-assemble the power module assembly, make sure all connections are tight.

---

**⚠ WARNING**

---

**Do not connect the semi-conductor fuse, wires or fan wires at this point.**

### Check the SCR snubber card

1. Three components make up the SCR snubber—resistors, MOVs, and capacitors. Check for open resistors. Check MOVs for shorts, they should read high resistance when ohmmeter is placed across them. Resistance check each capacitor. The DC resistance across the snubber capacitor—should look capacitive—that is high resistance after the meter charges the capacitor. If it measures open or shorted, replace the snubber card.
2. **RE-CONNECT SEMI-CONDUCTOR FUSE, ALL WIRES, AND FANS. DOUBLE CHECK THAT ALL CONNECTIONS ARE SECURE.**

**Note:** Control board # 49120 is for 10 kVA to 50 kVA units.  
Control board # 407415 is for 75 kVA and larger.

---

**⚠ WARNING**

---

**Do not connect TB1, TB2, and TB3 connectors from the control cards #49120/407415 yet.**

### Check control card and filter card

1. Verify input to the conditioner matches the unit's specification. Also verify correct control board #49120/407415 jumper setup on **page 21**.
2. Disable the over/undervoltage shutdown card #35867 (optional card) by removing connectors K1 and K2 on the card.
3. Turn on AC input breaker to unit.

---

**⚠ IMPORTANT**

---

Extreme caution must be taken when measuring voltages on Molex connectors. Do not press meter leads into connectors or bend connectors back.

4. Measure the following voltages on wires feeding the TB1 Molex connector to the control card on all three phases.

Pins 1 and 3 = 4–6 Vac.

**Note:** When the connector is plugged in, this voltage is around 3 Vac.

Pins 7 and 8 = 120 Vac

If this voltage is incorrect or not present, then check the fuses associated with the filter card or replace filter card and re-check voltages.

5. Turn main AC circuit breaker off. Plug in connectors TB1 and TB3 only. On the control card #49120 / 407415 on all three phases.
6. Turn main AC on. With DC voltmeter on the millivolt scale, check between TP1 and TP GND of the control card and adjust pot P2 so meter reads "0" millivolts or close as possible.

**Note:** This step does not apply to control board # 407415.

**Note:** Refer to **page 21** for test points and pot locations on control card.

7. Use the following formula to calculate the next adjustments. You must calculate each input phase for each control card or a total of three calculations.
  - a. For phase 1 control card, measure AC input at Line 1 to Line 2.
  - b. For phase 2 control card, measure AC input at Line 2 to Line 3.
  - c. For phase 3 control card, measure AC input at Line 1 to Line 3.

**Formula**

$$\text{AC Input} \times 2.47 = \text{Volts DC at TP2} \\ 480 \text{ (Nominal)}$$

**Example**

$$475 \text{ Volts AC Input} \times 2.47 = 2.44 \text{ Volts DC at TP2} \\ 480 \text{ (Nominal)}$$

## Final testing and adjustment

- After calculations are complete, place DC voltmeter on the 20V scale and check between TP2 and TP GND on control card. Adjust pot P1 so meter reads DC level calculated in Step 7 for all three phases.

**Note:** If adjustments in Steps 6 and 7 are not possible, replace control card # 49120/407415 and repeat Steps 6 and 8.

**Note:** Be sure to turn power off when replacing circuit boards.

**Note:** Be sure AC input is stable when making this adjustment. If the input changes, you must re-calculate.

**Note:** Output voltage correction is a "stepped correction"; adjusting P1 will not cause a smooth change in output voltage as it is adjusted.

- Turn the unit off. Plug in TB2 Molex connectors to all the control cards #49120 / 407415.

- Replace connectors K1 and K2 on over/under detect #35867.

**Note:** P1 pot turned clockwise = decrease in output voltage and counter-clockwise = increase in output voltage. By changing this adjustment on phase 1, you may see the output voltage change from line to neutral on two phases. It is best to use procedures in Steps 1–9 adjusting.

## Final testing and adjustment

- Connect AC voltmeter to output of system with proper meter scale selected.

**Note:** On three-phase systems, connect your AC voltmeter across the output phase to neutral.

- Disconnect customer's loads.

- Energize system.

- Verify the output is within specifications. If not, adjust P1 on control board, for the appropriate phase. See adjustment procedure on **page 22**.

**Note:** On three-phase systems, be sure and check all three phases.

**Note:** If the main AC breaker trips or there is no output voltage, disable the over/under detect circuit #35867 by disconnecting K1 and K2 connectors, then calibrate the control boards if the output voltage is out of spec. See control card adjustment procedure on **page 22**.

- Turn the input circuit breaker off.

- Connect customer's equipment.

- Energize system.

- Repeat Step 4 and adjust as needed.

- Be sure over/under detect is connected and if input breaker trips or there is no output voltage, re-calibrate the detect board or replace board if defective (see adjustment procedure on **page 22**).

Figure 4. Unit Component Location Diagram

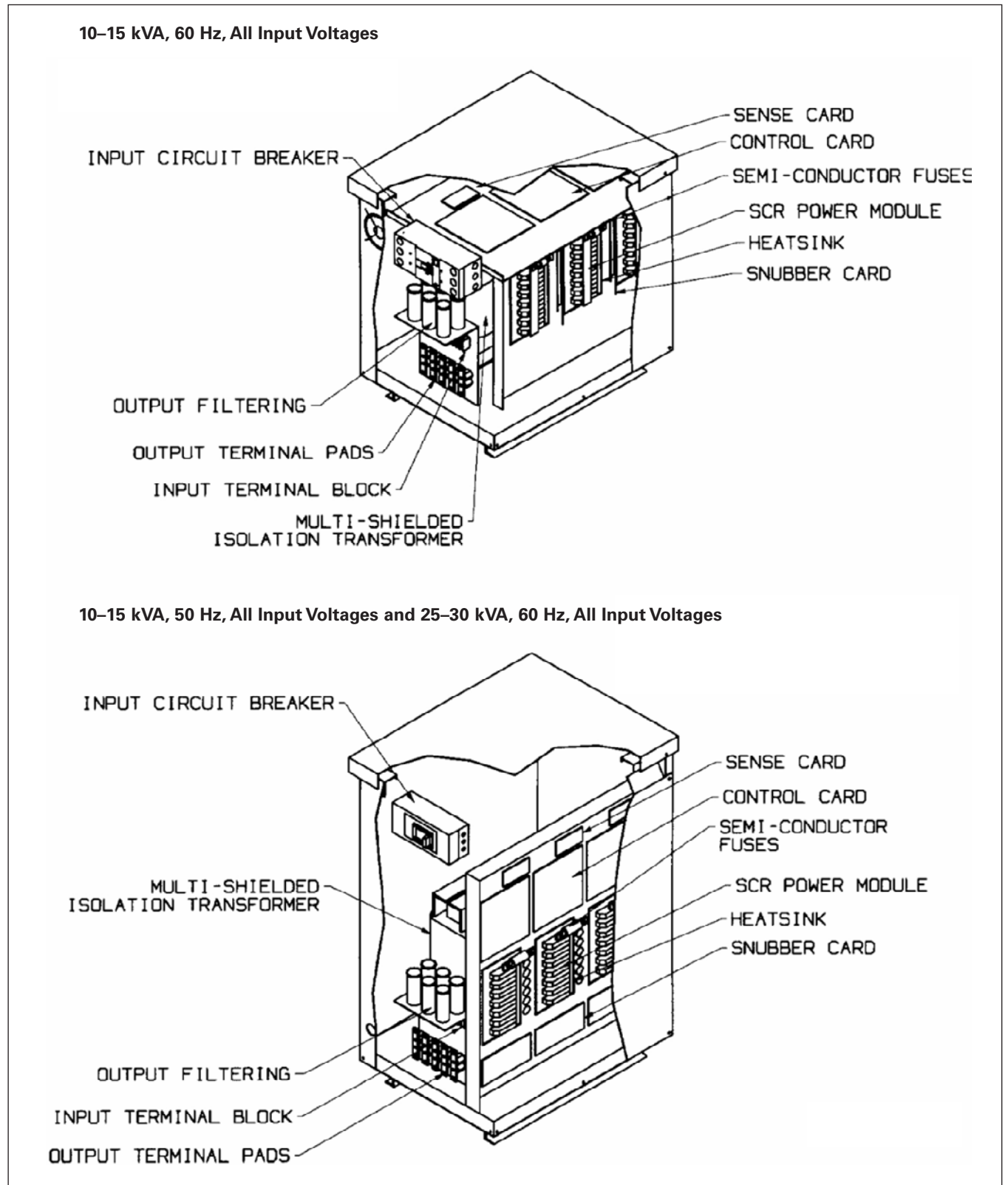

Figure 5. Unit Component Location Diagram (45–150 kVA, 60 Hz / 30–100 kVA, 50 Hz)

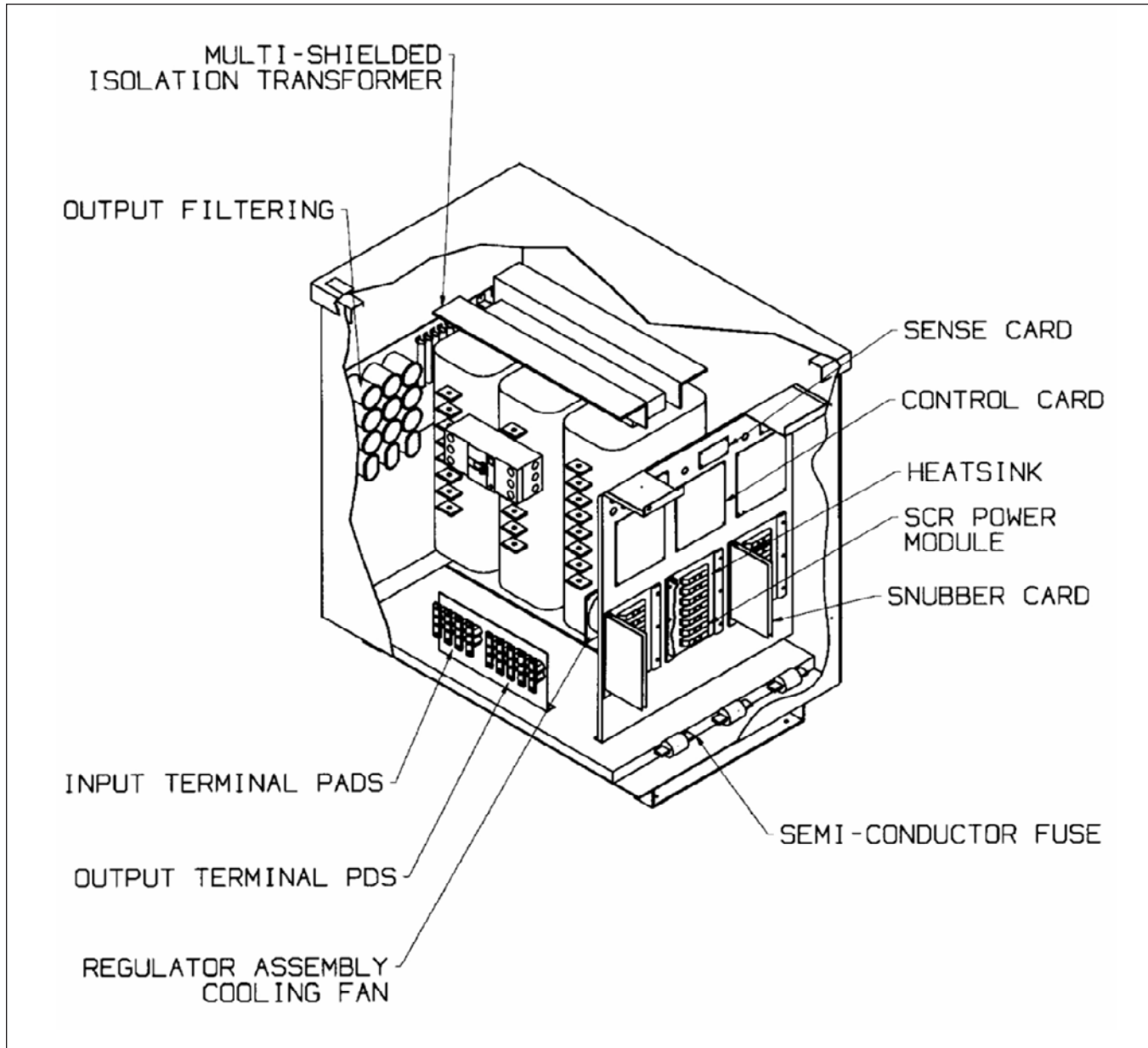



Figure 6. Power-Sure 700 50K Component Location

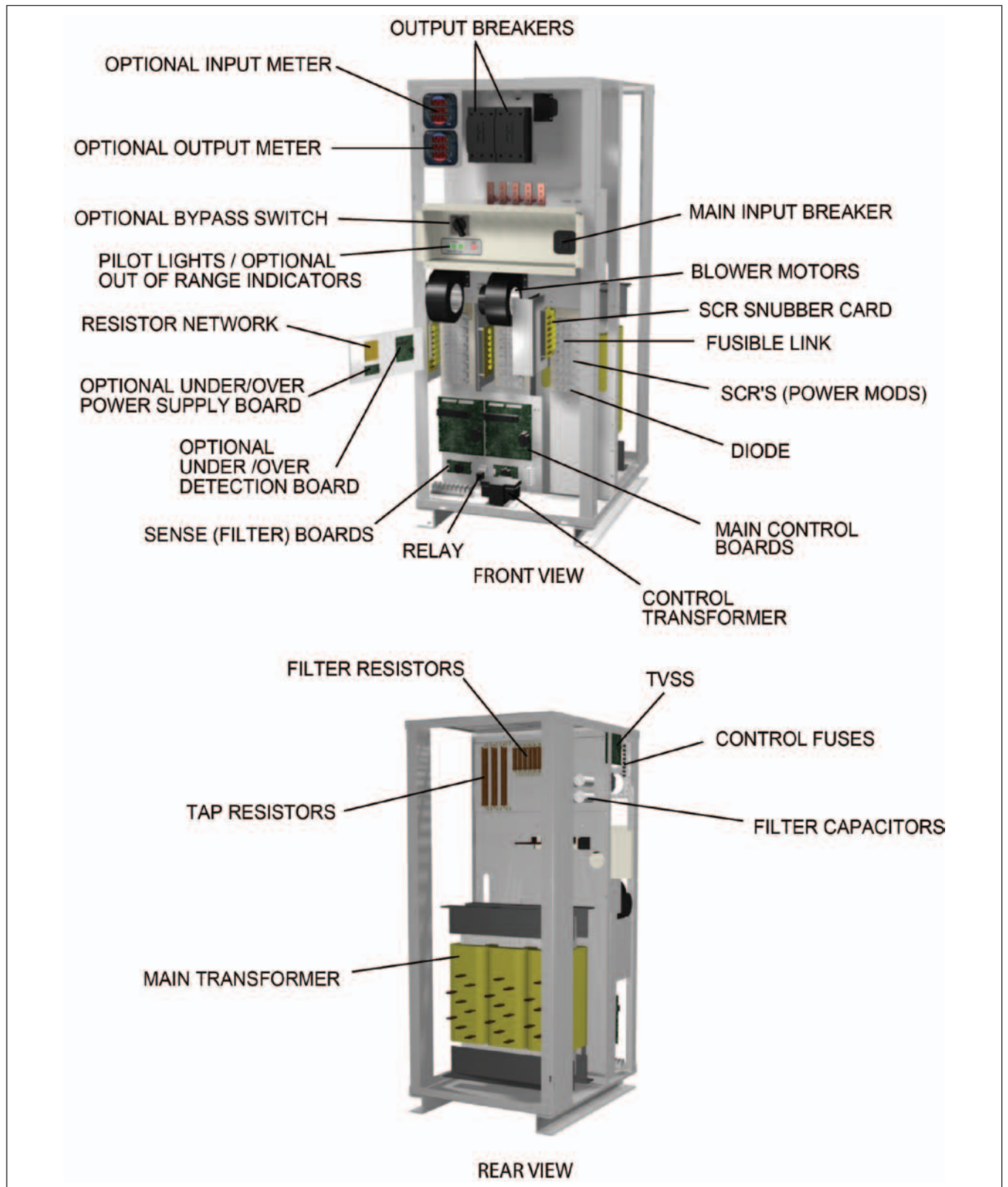

Figure 7. Power-Sure 700 75–150K Component Location

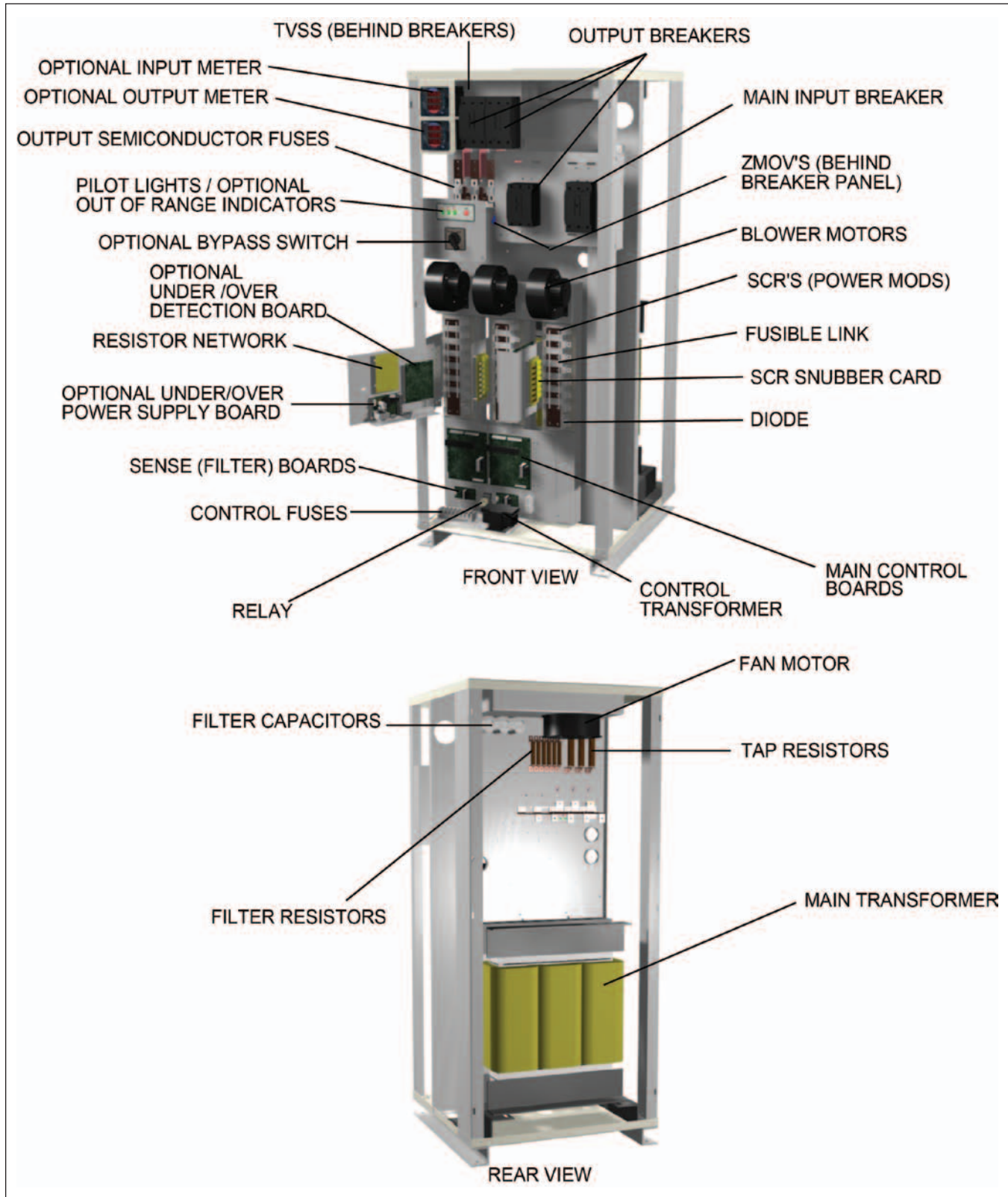

Figure 8. Unit Component Location Diagram (225–300 kVA 50/60 Hz, All Voltages)

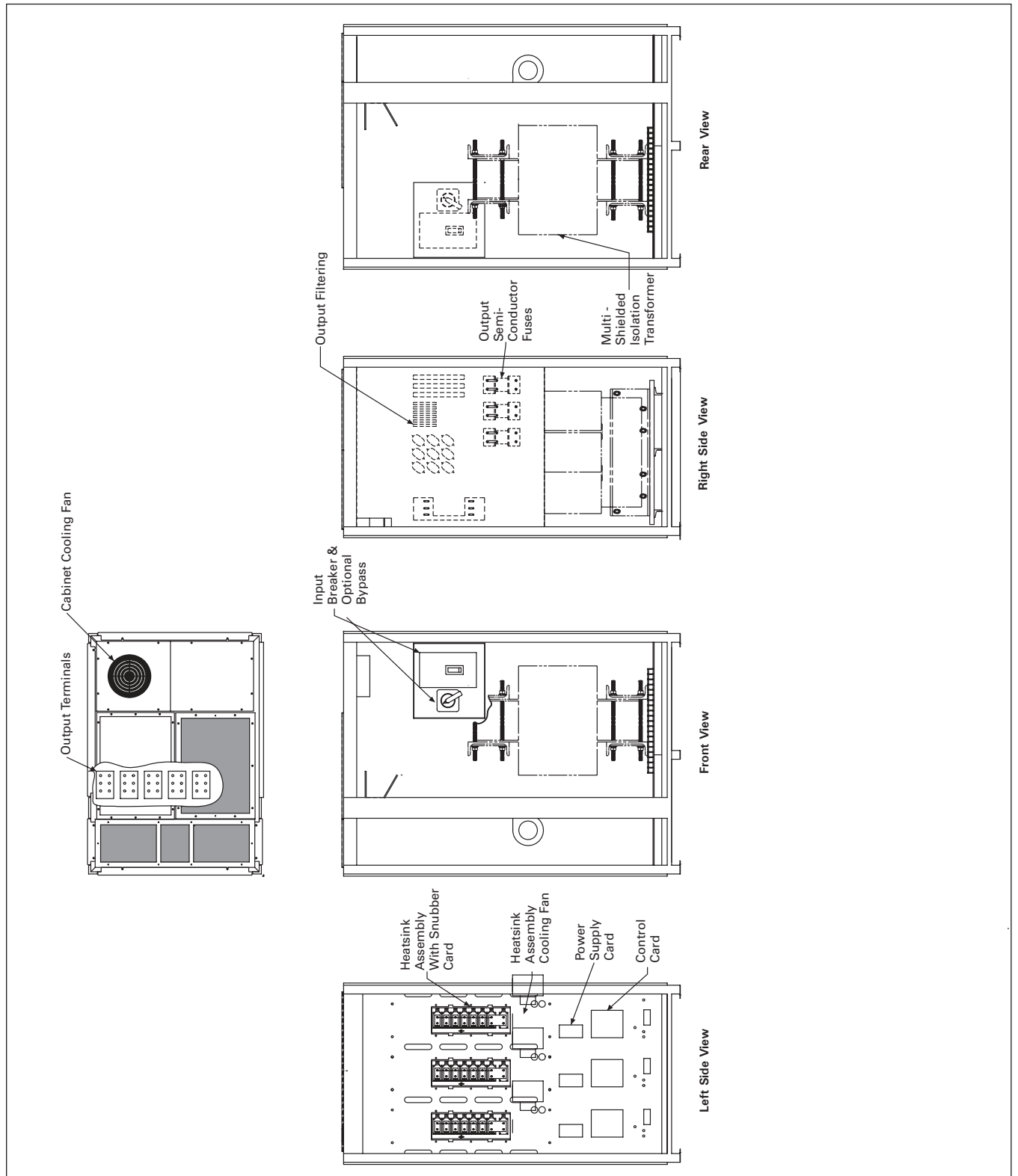
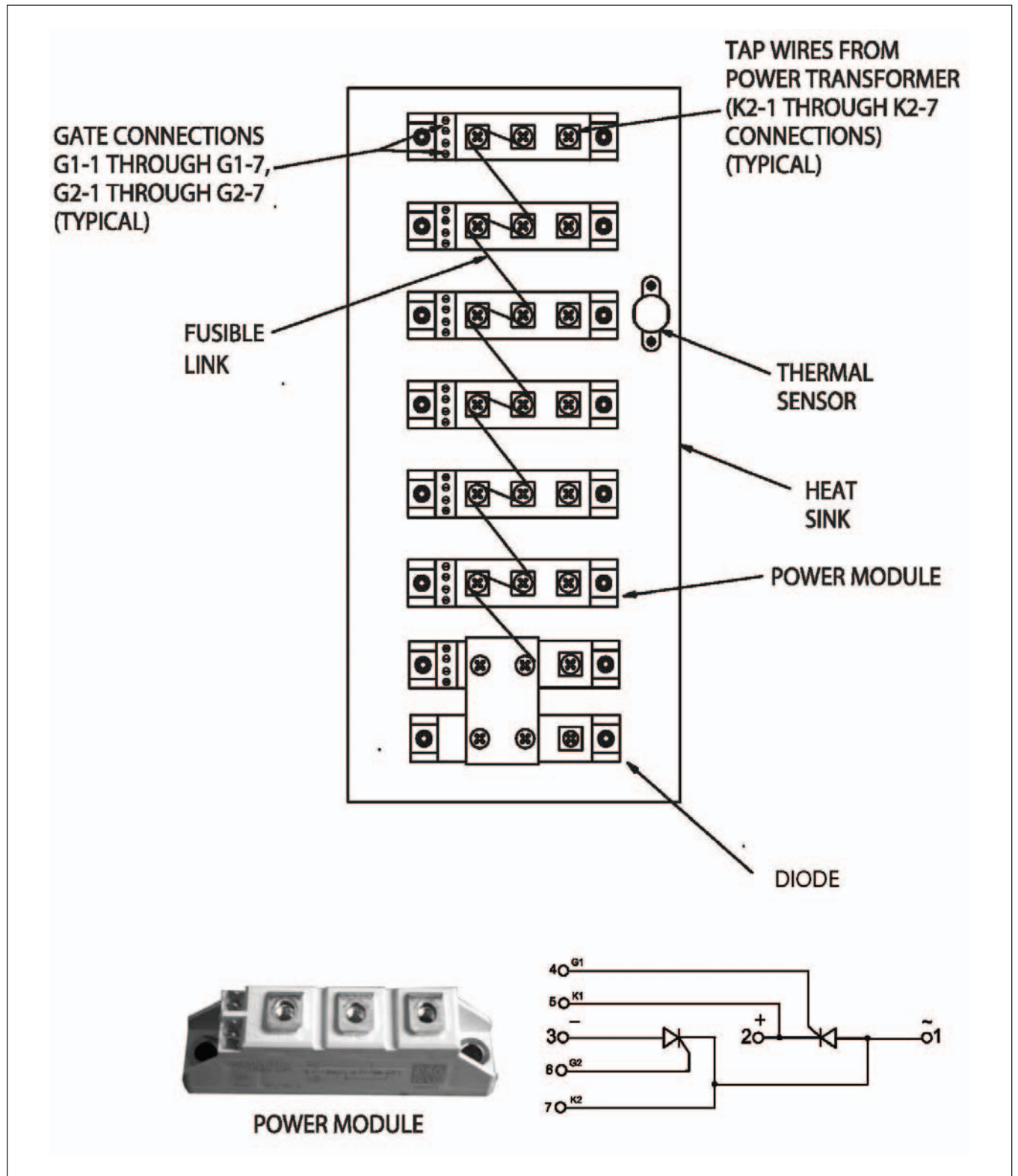

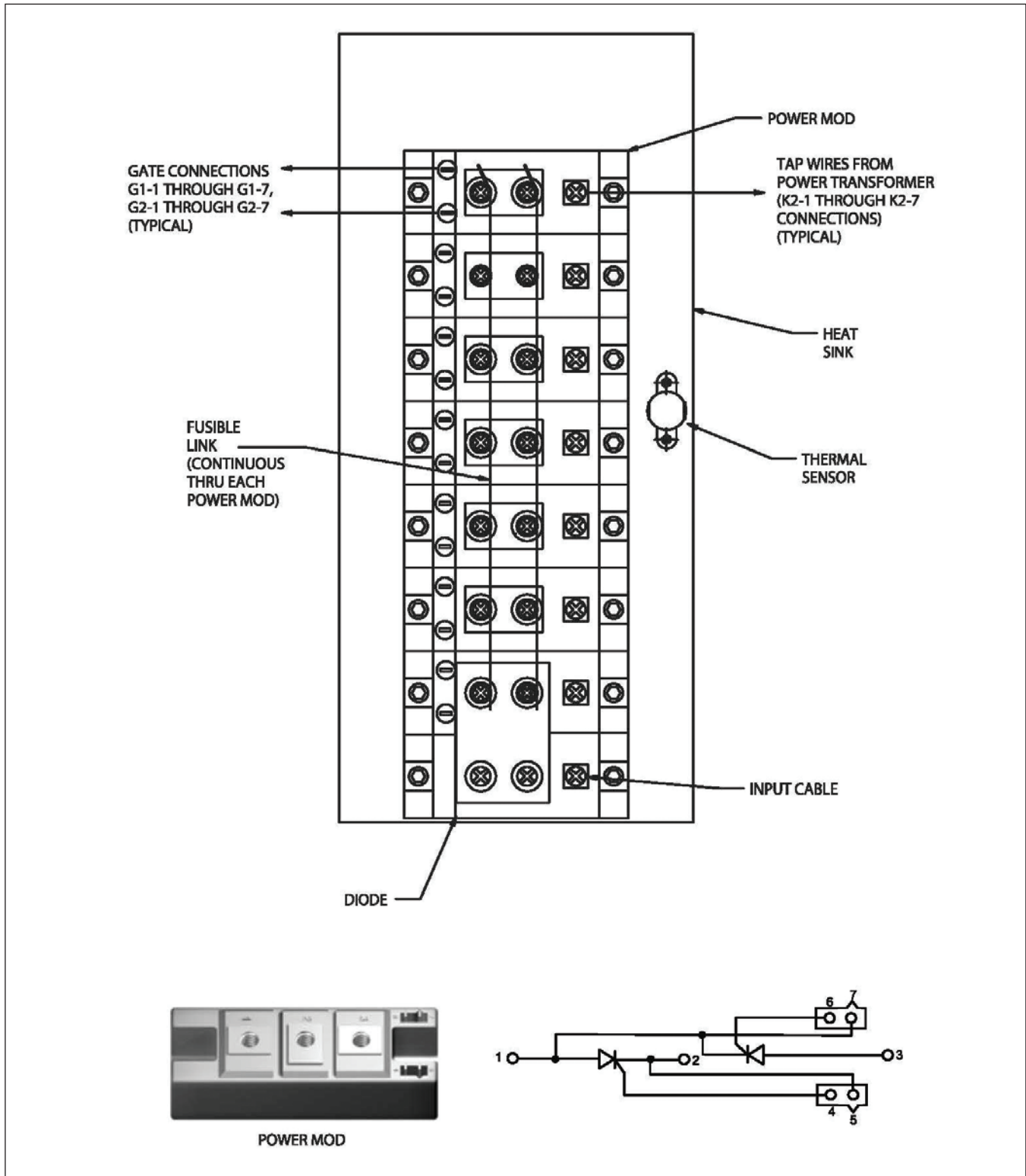

Figure 10. 10–30 kVA Heat Sink Layout ①



① Heat sink layout does not necessarily follow kVA size shown. Input voltage is also a factor in heat sink layout.

Figure 11. 45–150 kVA Heat Sink Layout ①



① Heat sink layout does not necessarily follow kVA size shown. Input voltage is also a factor in heat sink layout.

Figure 12. 225–300 kVA Heat Sink Layout ①

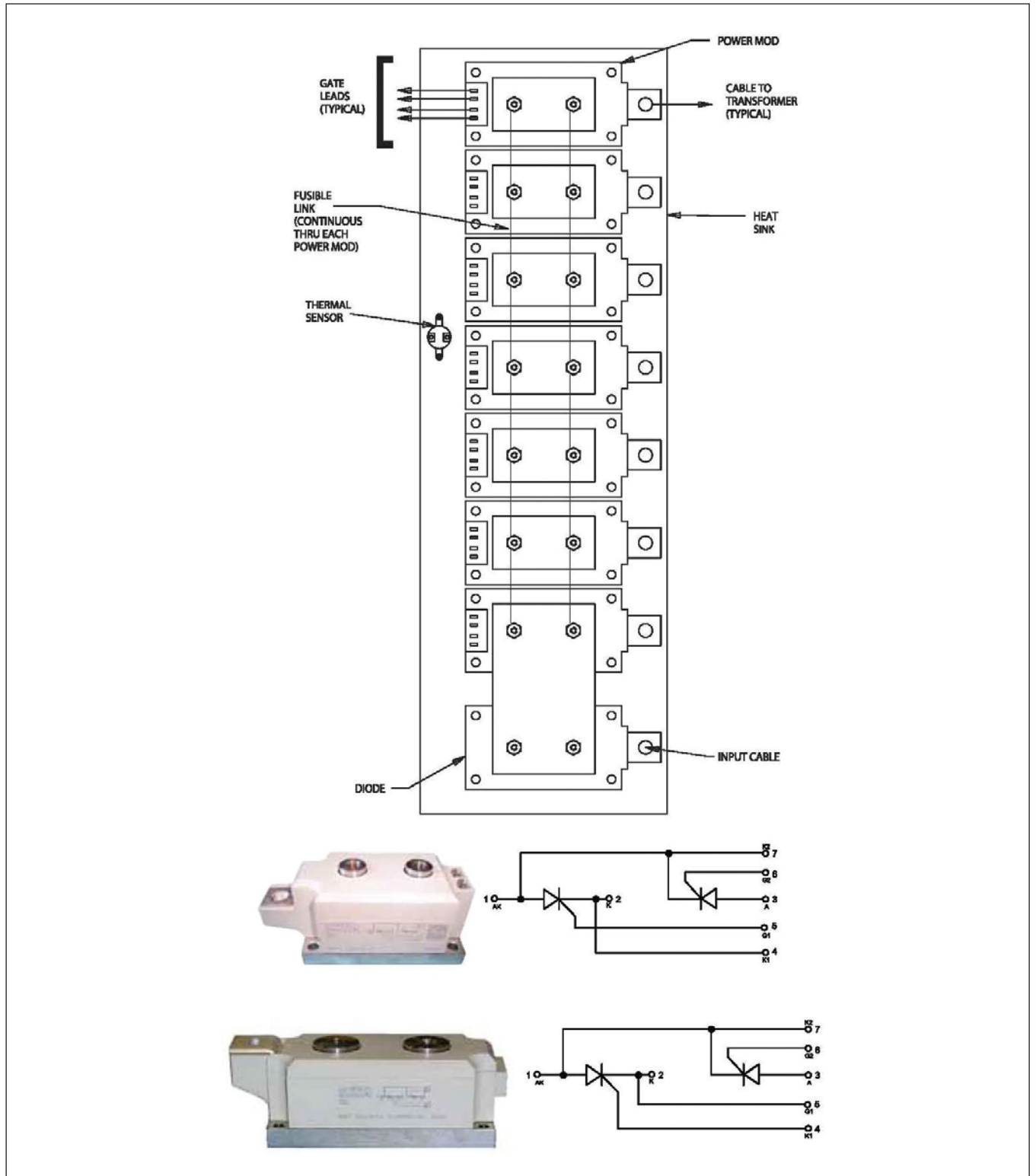

① Heat sink layout does not necessarily follow kVA size shown. Input voltage is also a factor in heat sink layout.

Figure 13. 500 kVA Heat Sink Layout ①

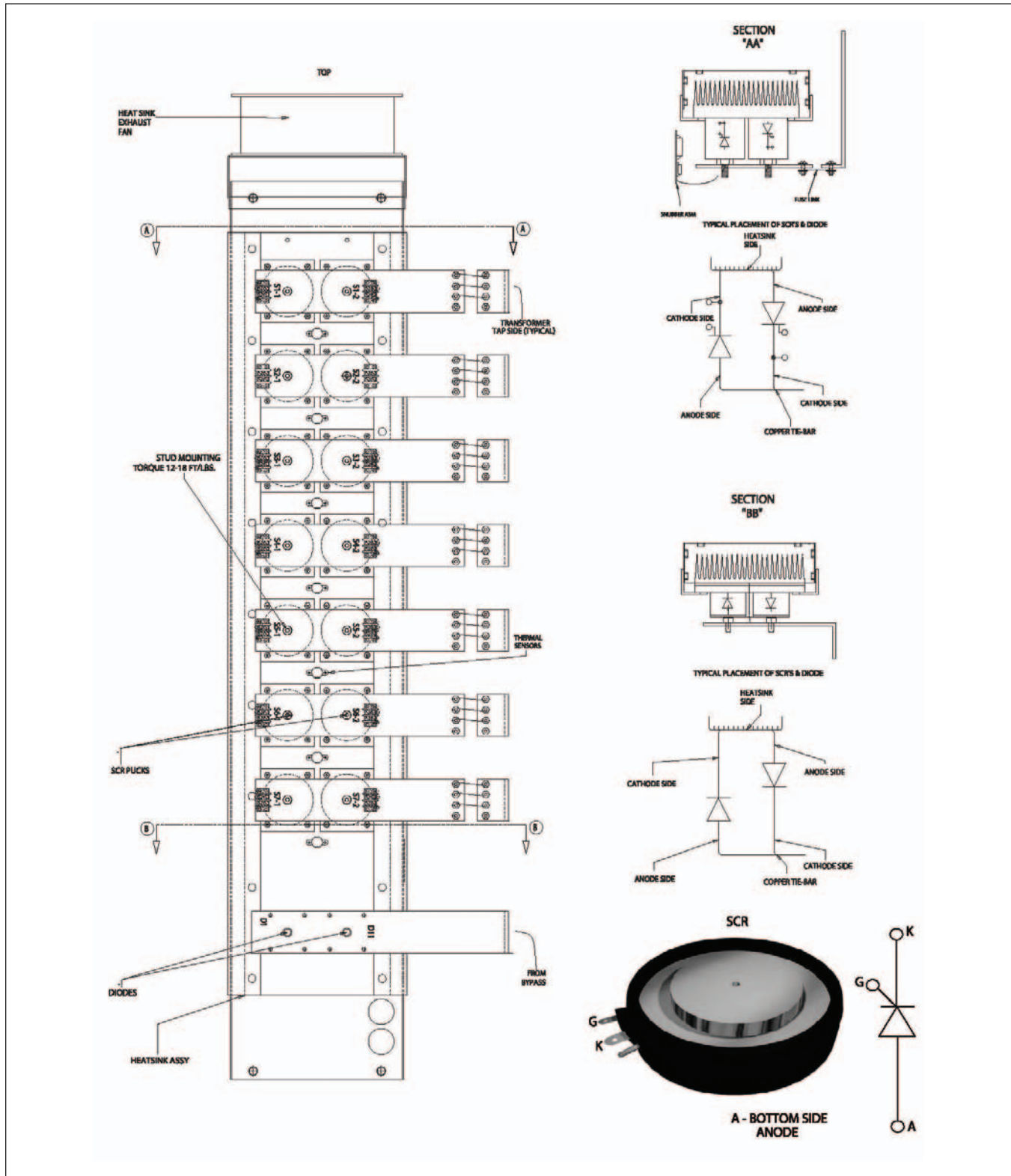

① Heat sink layout does not necessarily follow kVA size shown. Input voltage is also a factor in heat sink layout.



Figure 14. Control Board #49120/407415

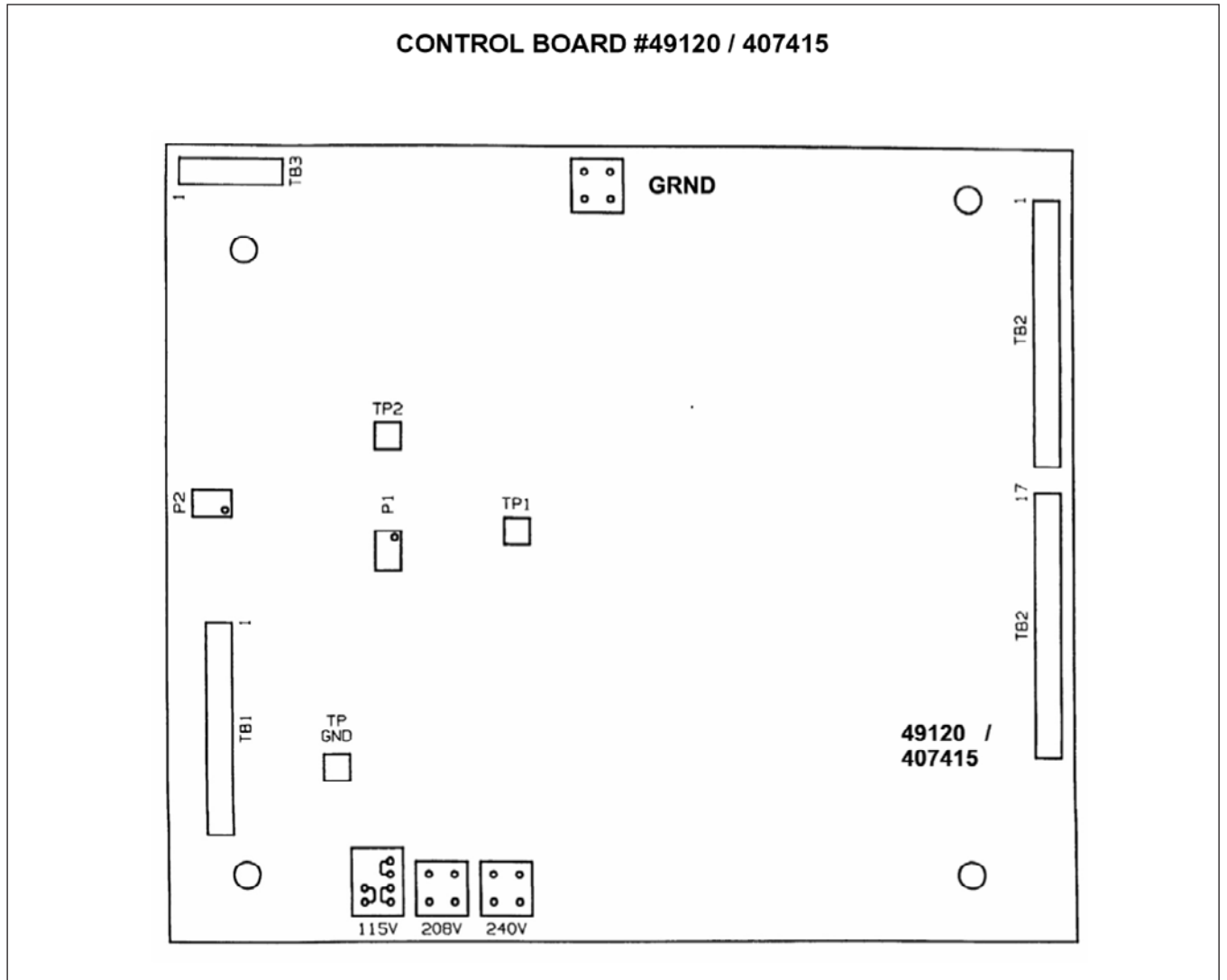

## Control board adjustments (#49120/407415) field adjustment procedure

### Control board adjustments (#49120/407415) field adjustment procedure

#### WARNING

All service to this piece of equipment must be performed by qualified personnel.

#### CAUTION

The control board (#49120/407415) is electrically referenced to high voltage, not earth or chassis ground. Extreme care must be used when taking measurements on the control board. Any AC powered instruments must be ground isolated prior to taking measurements. A ground isolated instrument case will be at the high voltage line potential.

### Adjustment procedure

1. Prior to attempting any adjustment, measure the incoming voltage to the unit. Ensure the voltage level is within the specified input range of the unit.
2. Turn off power to unit.
3. Remove all loads from the output of unit under adjustment.
4. Remove both TB2 connectors on all control boards #49120/407415 (see **page 21**). Turn power on.
5. With DC voltmeter on the millivolt scale, check between TP1 and TP GND and adjust P2 so meter reads "0" millivolts or as close as possible.

**Note:** Refer to **page 21** for test points and pot locations.

6. Use Formula X to calculate the next adjustments. You must calculate each input phase for each control card or a total of three calculations.
  - a. For phase 1 control card, measure AC input at Line 1 to Line 2.
  - b. For phase 2 control card, measure AC input at Line 2 to Line 3.
  - c. For phase 3 control card, measure AC input at Line 1 to Line 3.

#### Formula

$\frac{\text{AC Input} \times 2.47}{480}$  (Nominal) = Volts DC at TP2

#### Example

$\frac{475 \text{ Volts AC Input} \times 2.47}{480}$  (Nominal) = 2.44 Volts DC at TP2

**Note:** Be sure AC input is stable when making this adjustment. If the input changes, you must re-calculate.

7. After calculations are complete, place DC voltmeter on 20V scale and check between TP2 and TP GND on control card. Adjust pot P1 so meter reads DC level calculated in Step 6 for all three phases.

**Note:** Output voltage correction is a "stepped correction"; adjusting P1 will not cause a smooth change in output voltage as it is adjusted.

8. Turn unit off and reconnect TB2 connectors on all control boards.
9. Turn unit on, verify output is correct by monitoring the output from each line to neutral. If not, make sure input power is stable and repeat adjustment procedure.

**Note:** P1 pot turned clockwise = decrease in output voltage and counter clockwise = increase in output voltage. By changing this adjustment on 1 phase you may see the output voltage change from line to neutral on 2 phases. It is best to use procedures in Steps 1–9 when adjusting.

### Parts kits

Table 5. 50 and 60 Hz, All Voltages

kVA Size	Kit Price (U.S. Funds)
10 kVA	Consult Factory
15 kVA	Consult Factory
25–50 kVA	Consult Factory
75 kVA	Consult Factory
100–125 kVA	Consult Factory
150 kVA	Consult Factory
225 kVA	Consult Factory
300 kVA	Consult Factory
500 kVA	Consult Factory

**Note:** Each parts kit includes the following:  
(7) Power Modules (SCRs)  
(3) Semiconductor Fuses  
(1) Fusible Link (for one full phase)  
(2–4) Fan Motors (depending on unit size)  
(1) SCR snubber board  
(3) Sense fuses  
(1) Main control board

### Replacement parts

Individual components are also available upon request. Please contact the factory for specific part numbers and prices. See "Unit component location diagrams" on **page 11–page 16** for component location and description. When contacting Application Support, please have the unit's full model number and serial or system number. Call 1-800-809-2772, option 4, then option 2.

## Technical diagrams

Figure 15. Generic Circuit Diagram—Primary SCR—No Bypass

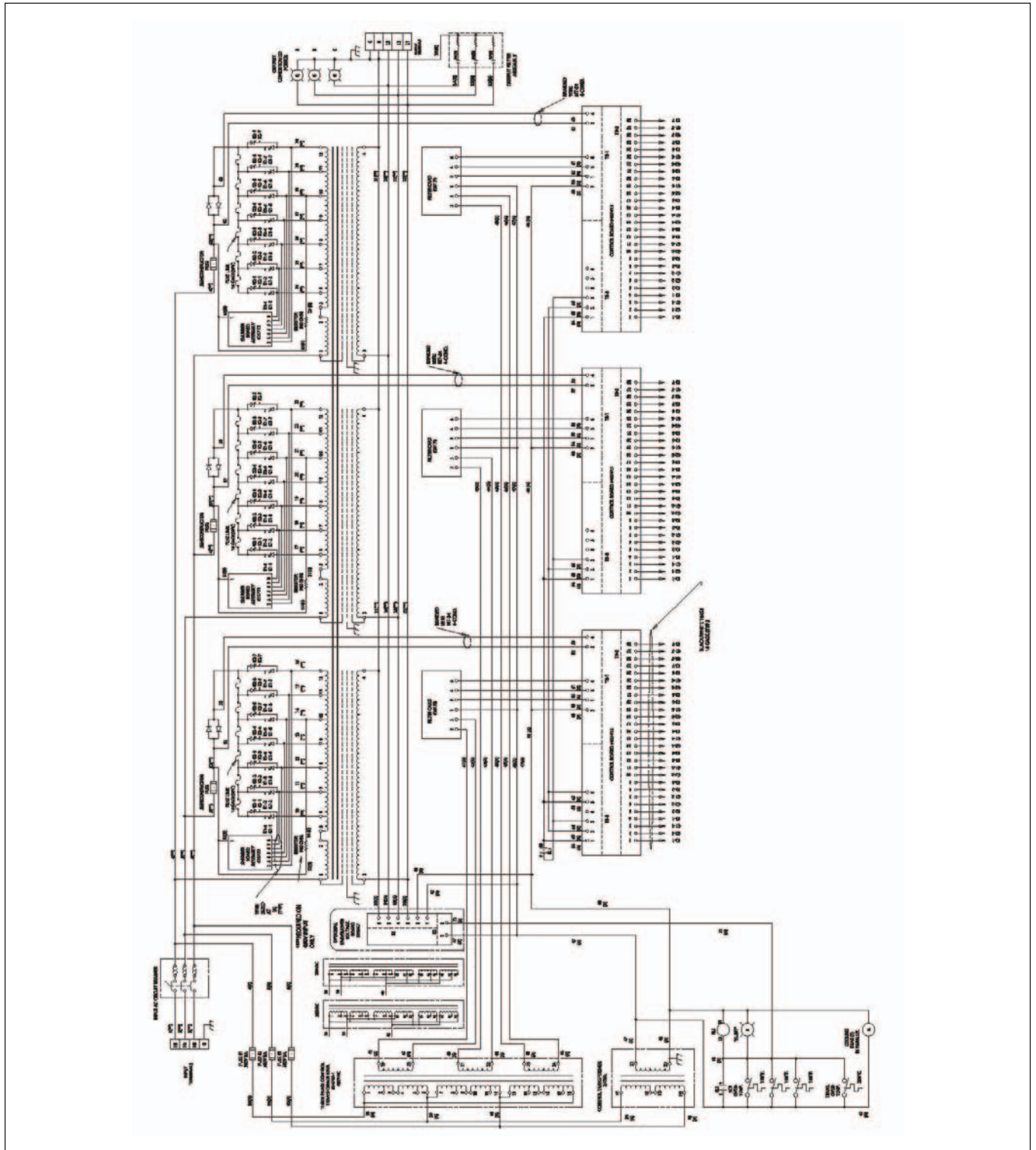

Figure 16. Generic Circuit Diagram—Primary SCR—With Bypass

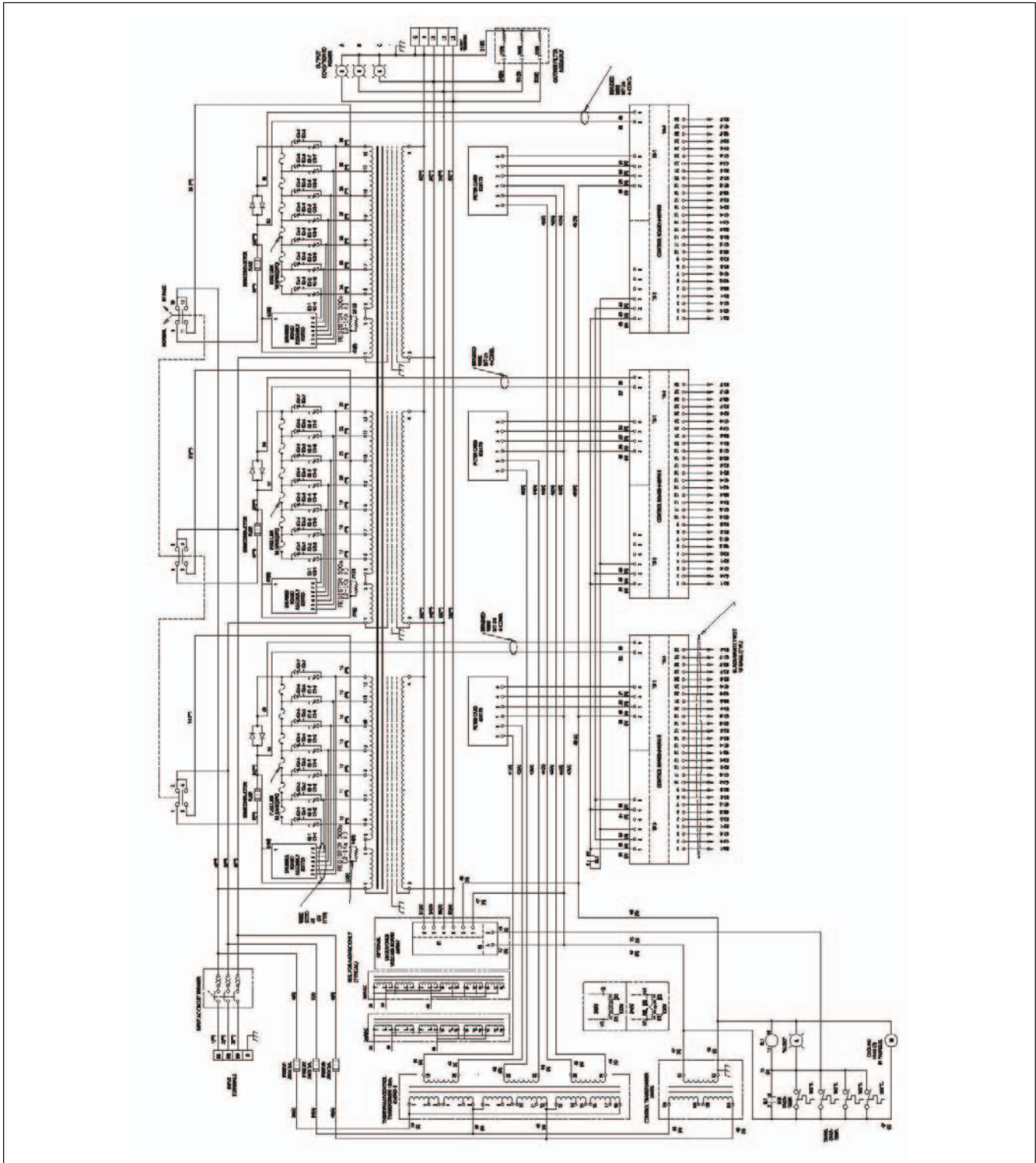

Figure 17. Generic Circuit Diagram—Secondary SCR—No Bypass

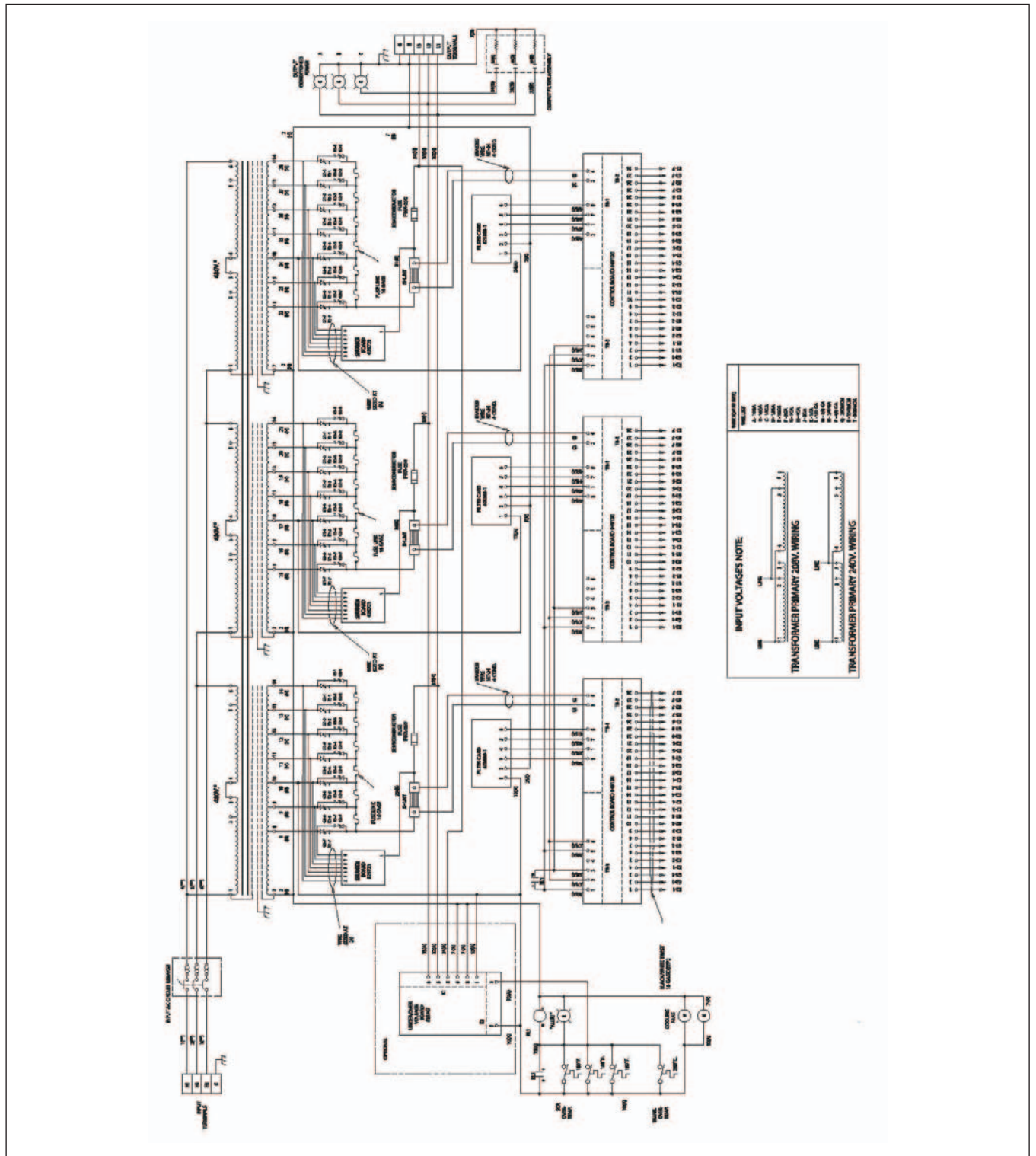

Figure 18. Generic Circuit Diagram—Secondary SCR—With Bypass

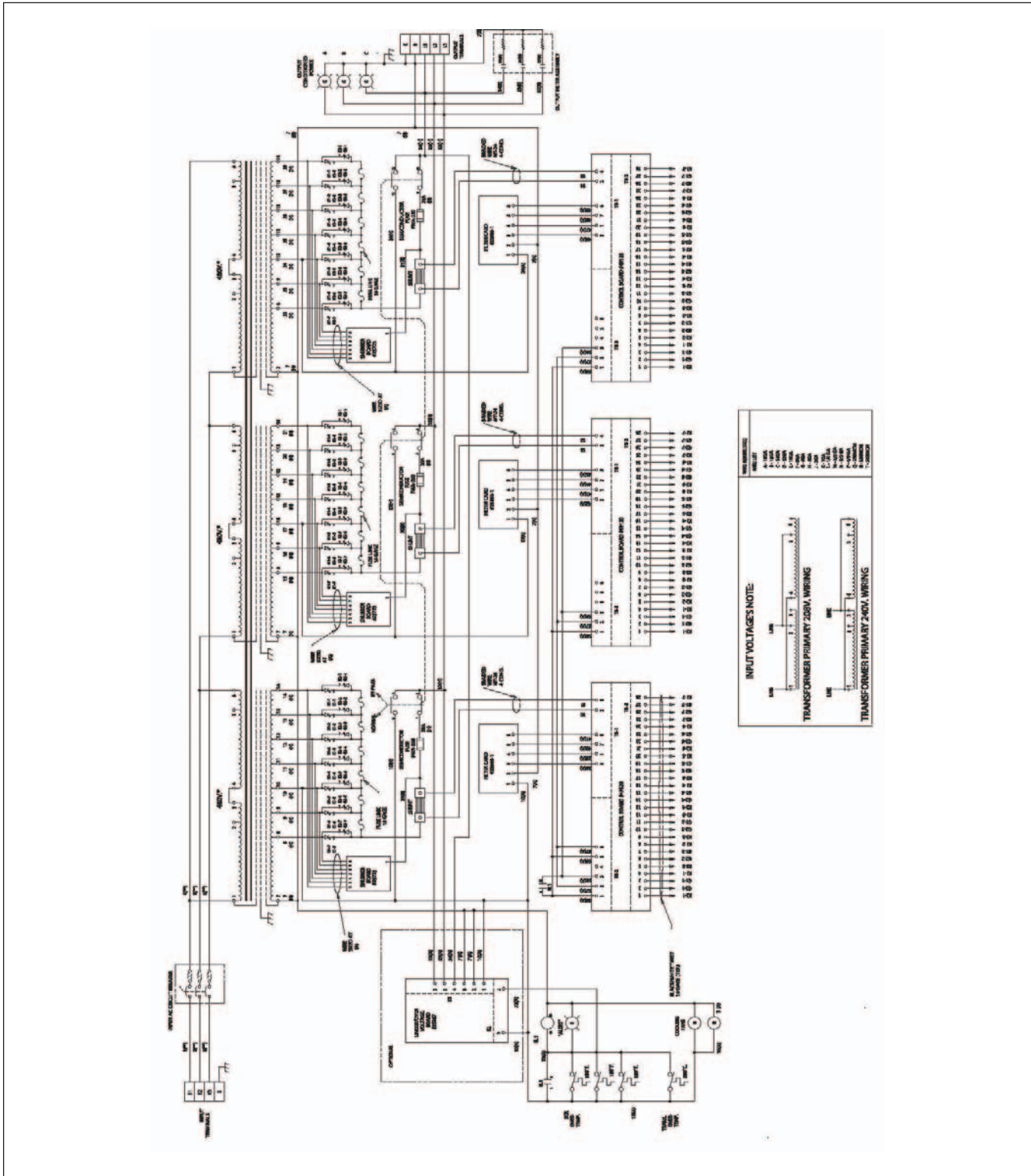

Figure 19. Installation Diagram—Power-Sure 700 10–15 kVA With Optional Bypass

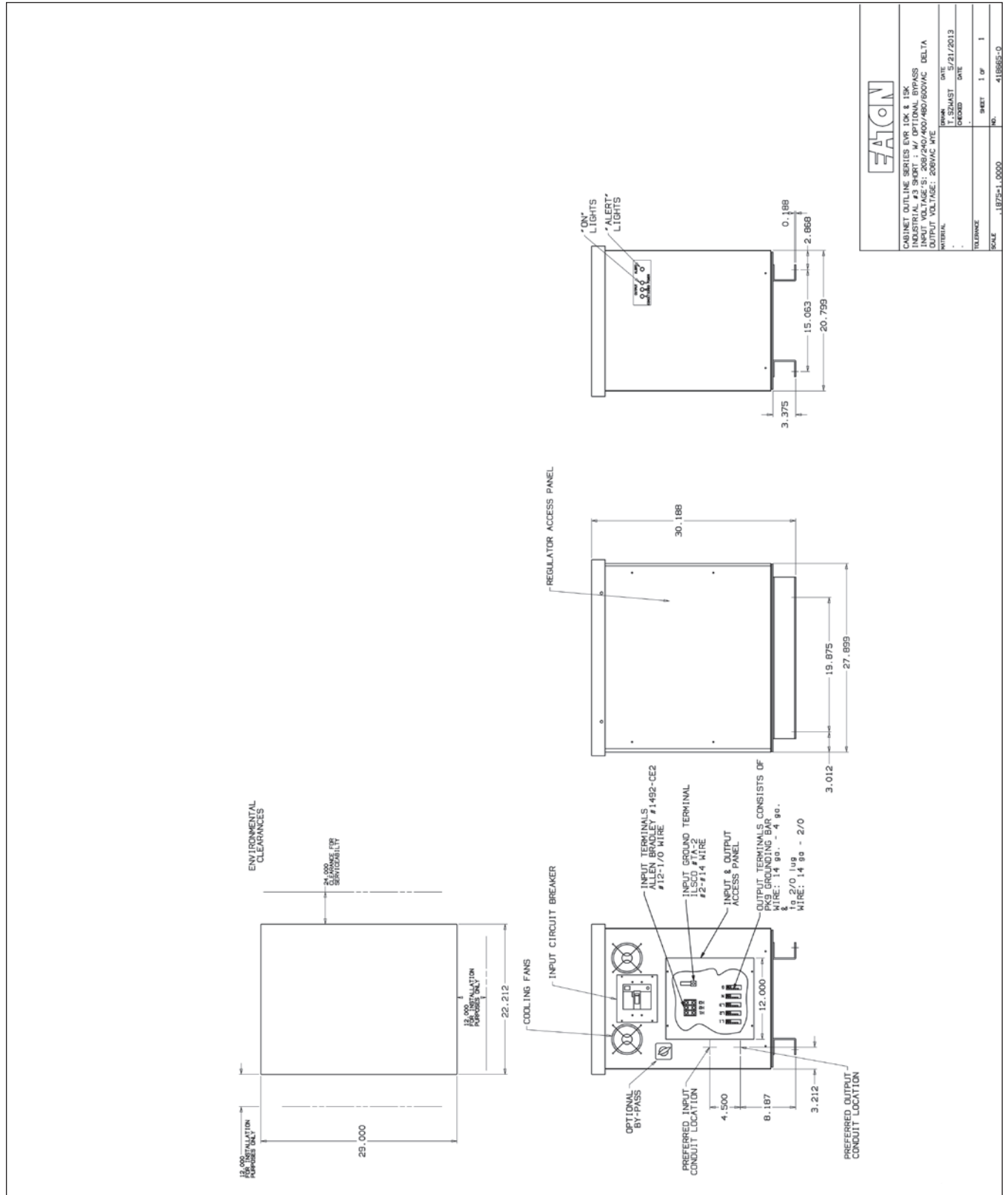

Figure 20. Installation Diagram—Power-Sure 700 10–30 kVA With Optional Meter and Bypass

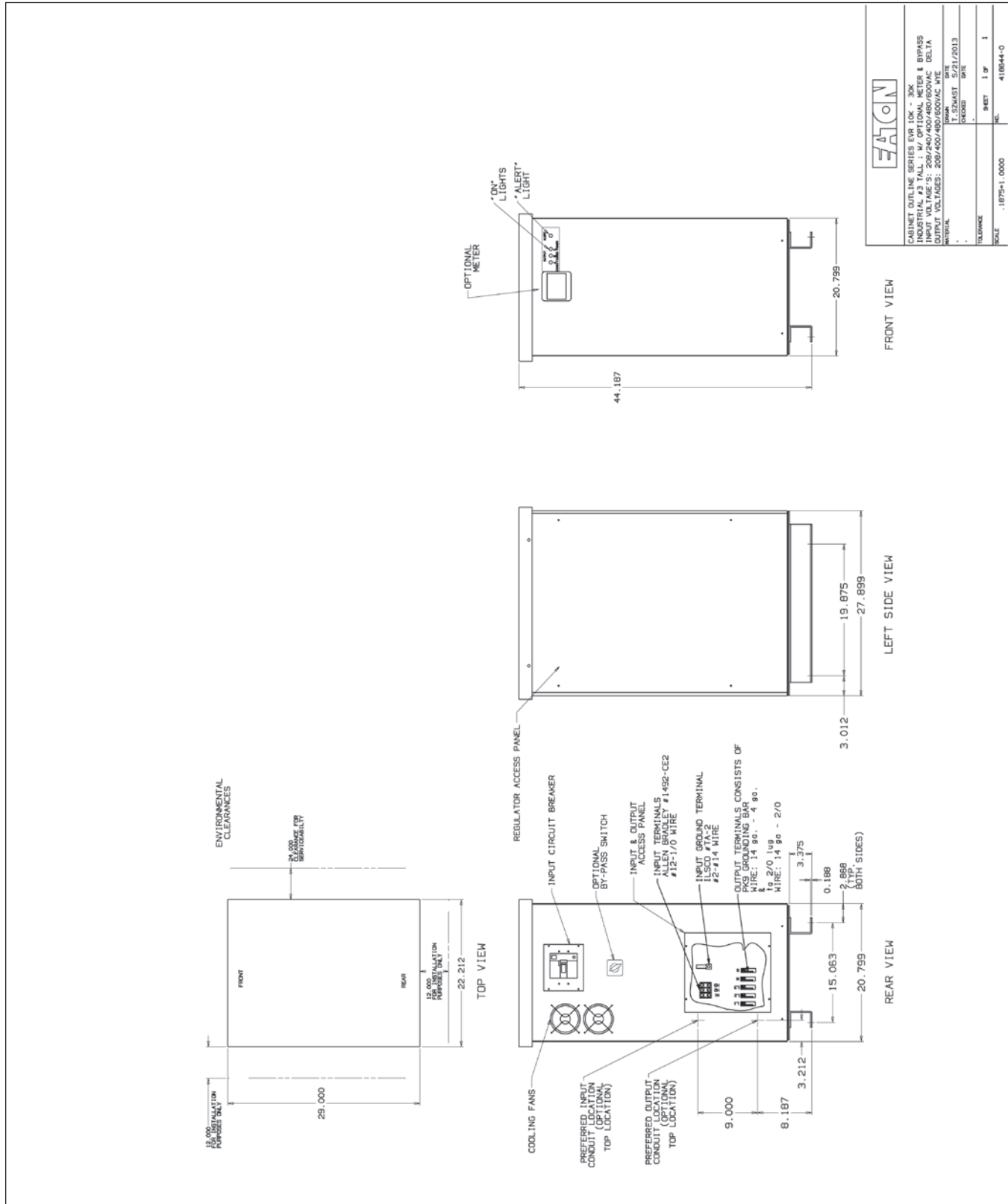



Figure 21. Installation Diagram—Power-Sure 700 45K With Optional Meter and Bypass

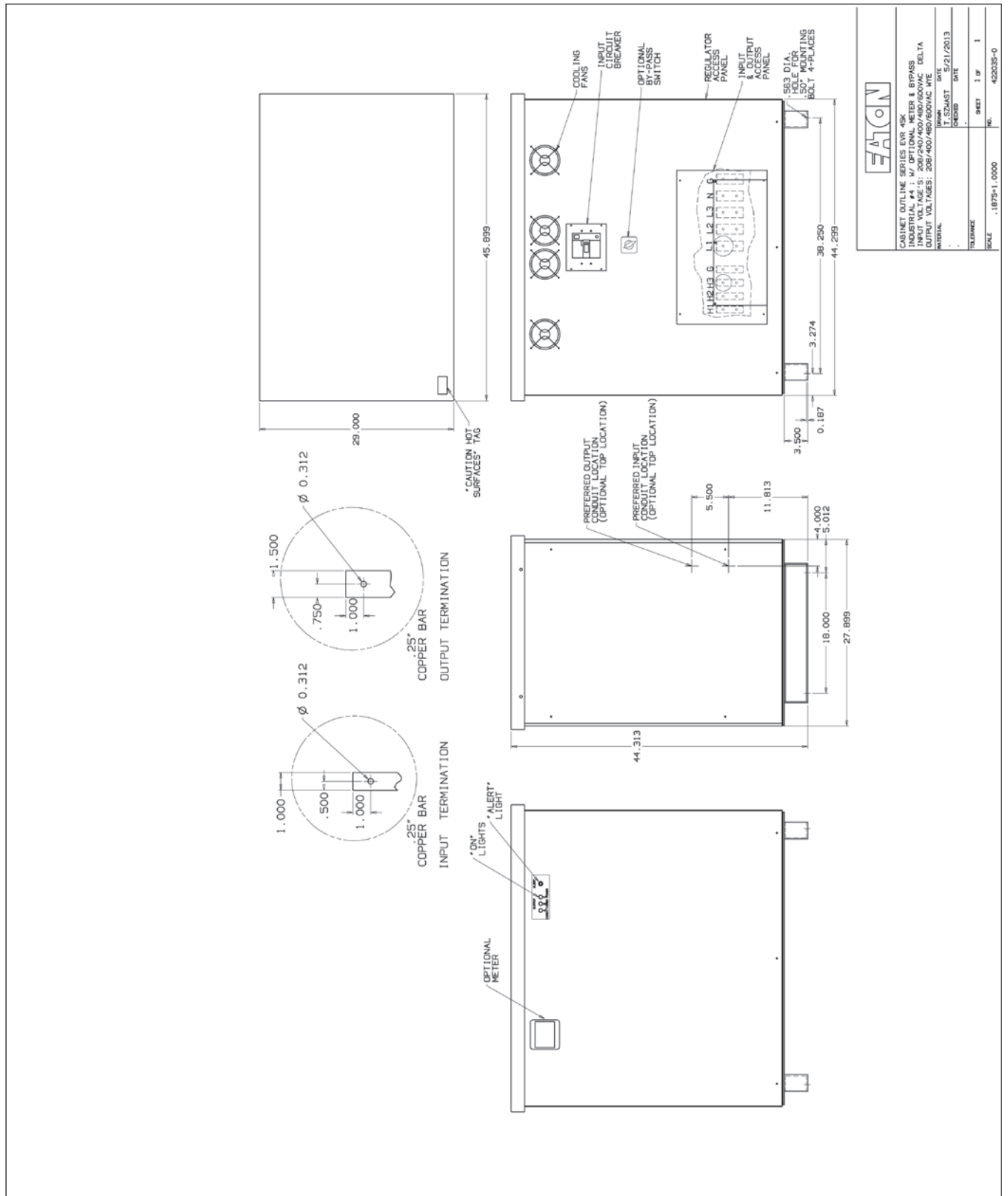

Figure 22. Installation Diagram—Power-Sure 700 50K With Bypass and Optional Meter

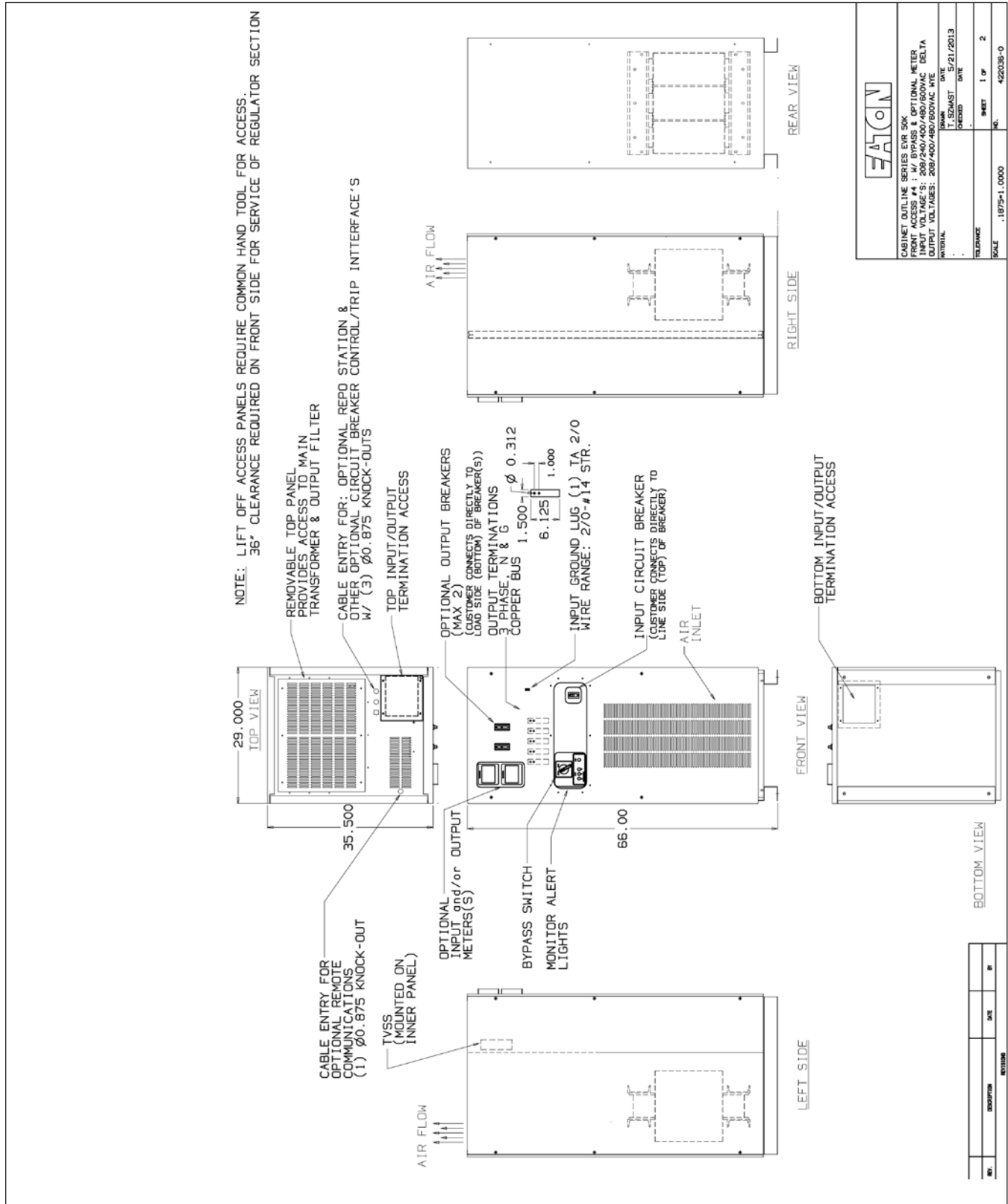

Figure 23. Installation Diagram—Power-Sure 700 50K With Bypass and Optional Meter (Top and Bottom View)

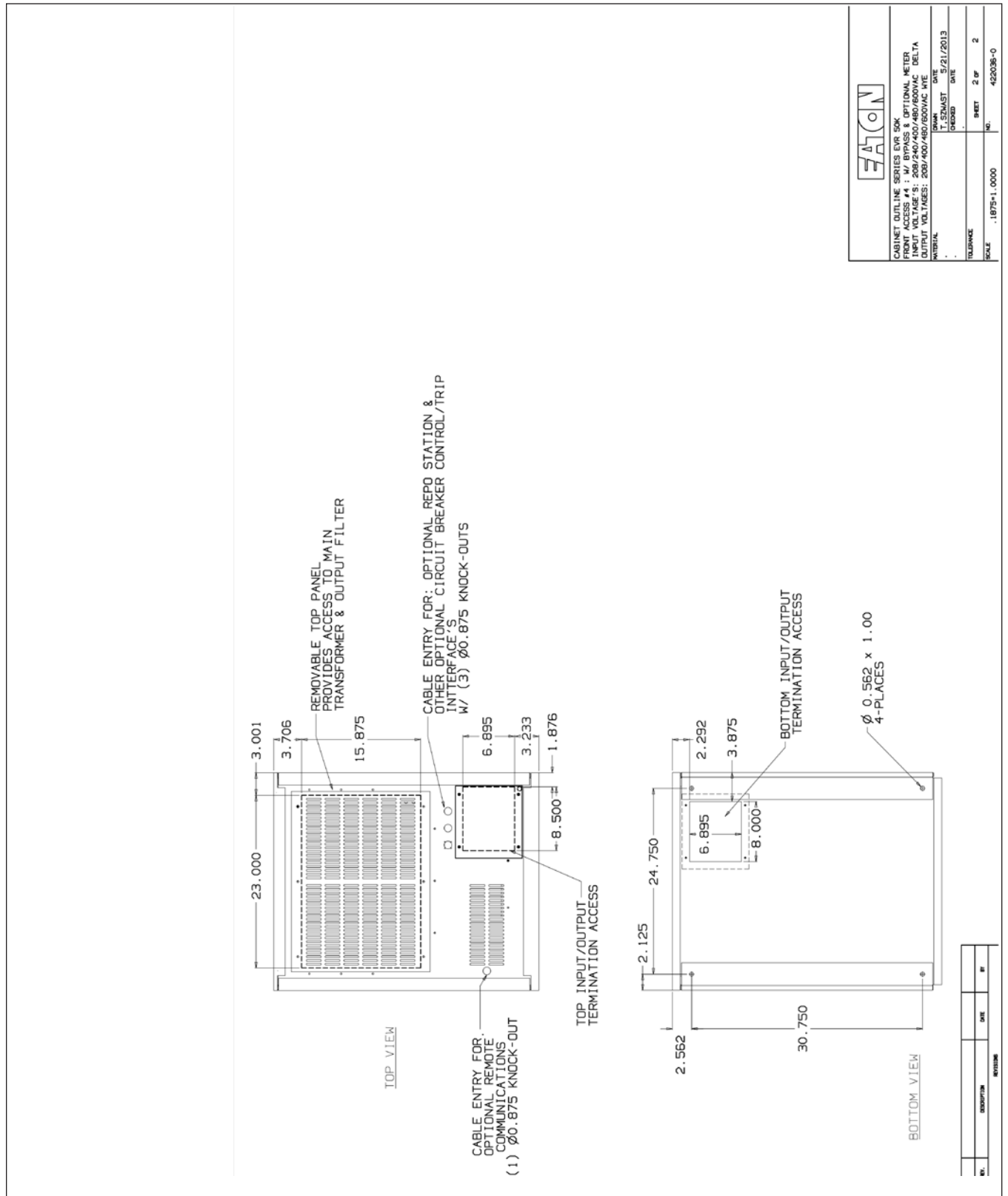
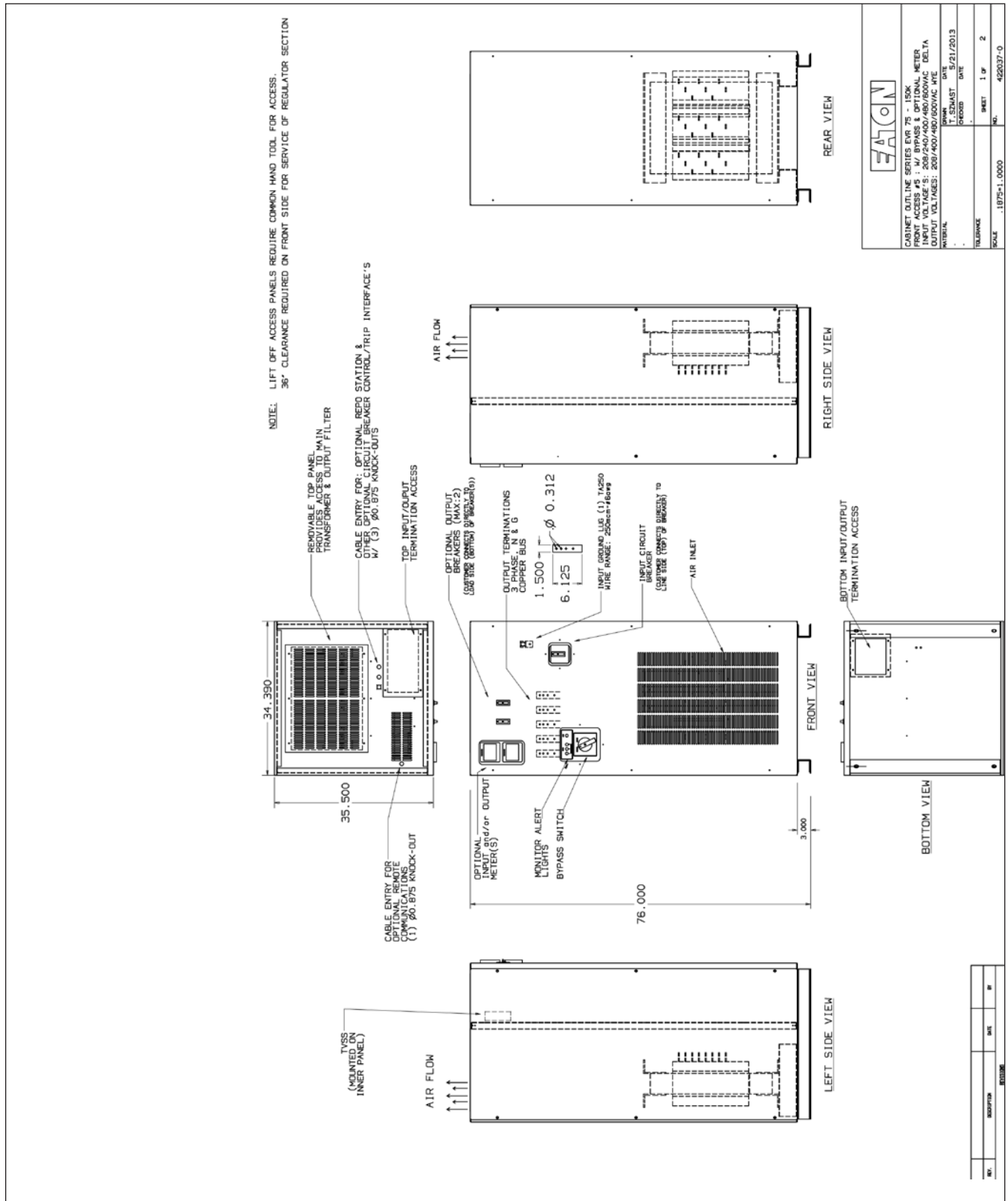

Figure 24. Installation Diagram—Power-Sure 700 75–150K With Bypass and Optional Meter



<b>EATON</b>	
CABINET OUTLINE SERIES EPO 75 - 150K	
FRONT ACCESS #5 : W/ BYPASS & OPTIONAL METER	
INPUT VOLTAGE'S : 208/240/480/600/690VAC DELTA	
OUTPUT VOLTAGES: 208/400/480/600VAC WYE	
REVISION	
BY: T. SCHMIST	DATE: 5/21/2013
ORDERED:	
TOLERANCE:	
SCALE: .1875=1, 0.000	SHEET 1 OF 2
	NO. 422037-0

NO.	DESCRIPTION	DATE	BY

Figure 25. Installation Diagram—Power-Sure 700 75–150K With Bypass and Optional Meter (Top and Bottom View)

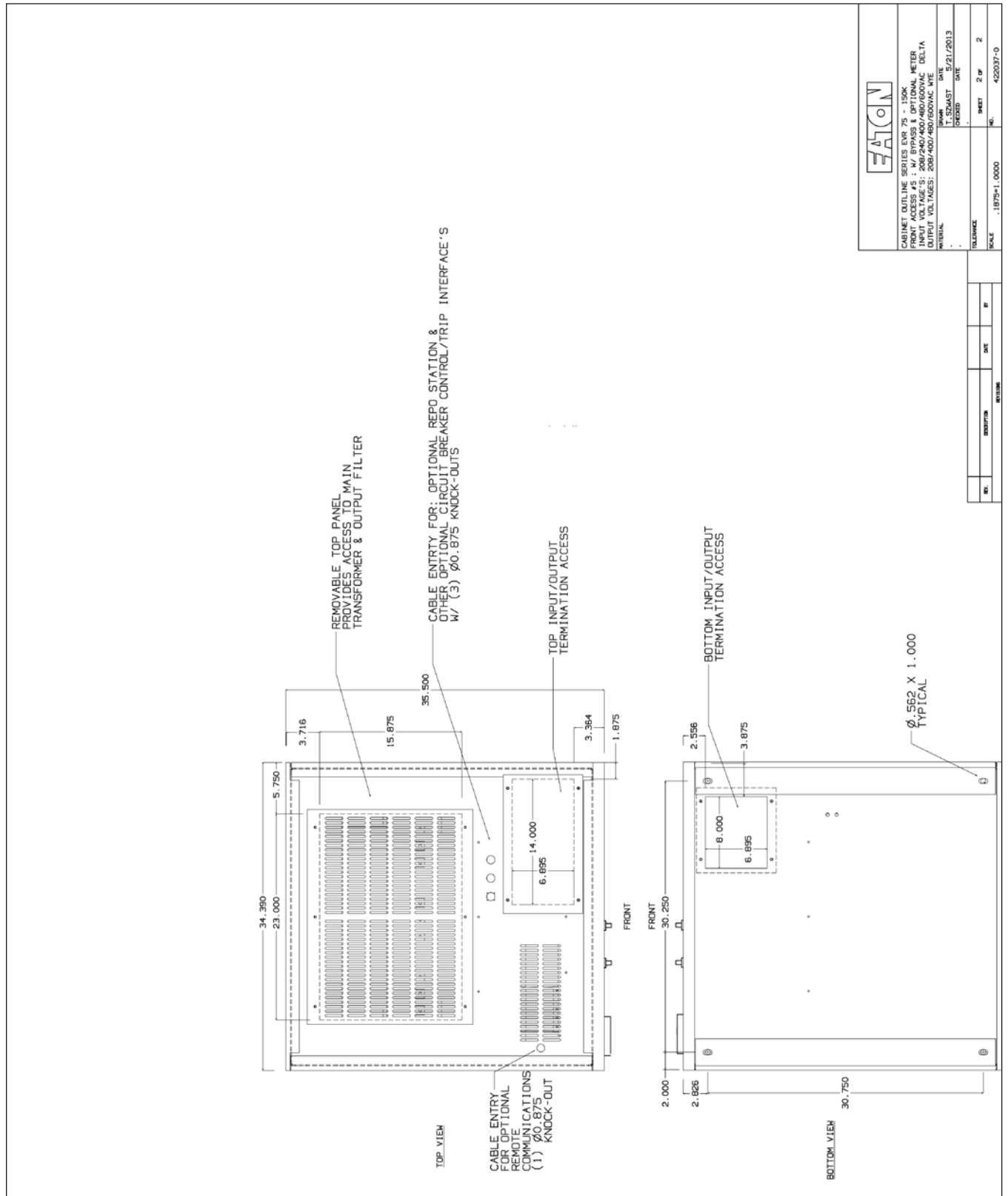

Figure 26. Installation Diagram—Power-Sure 700 225–300K With Bypass and Optional Meter

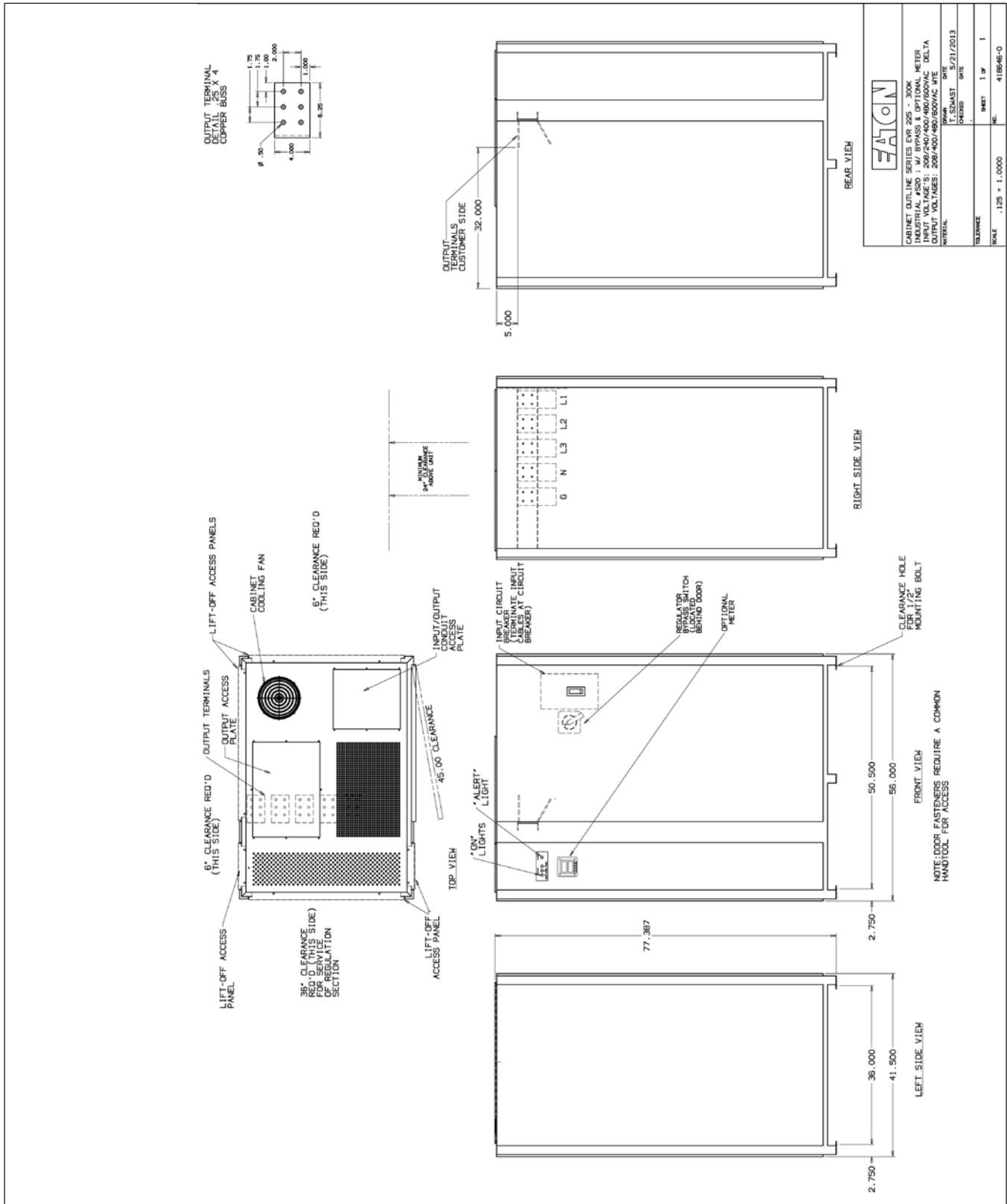
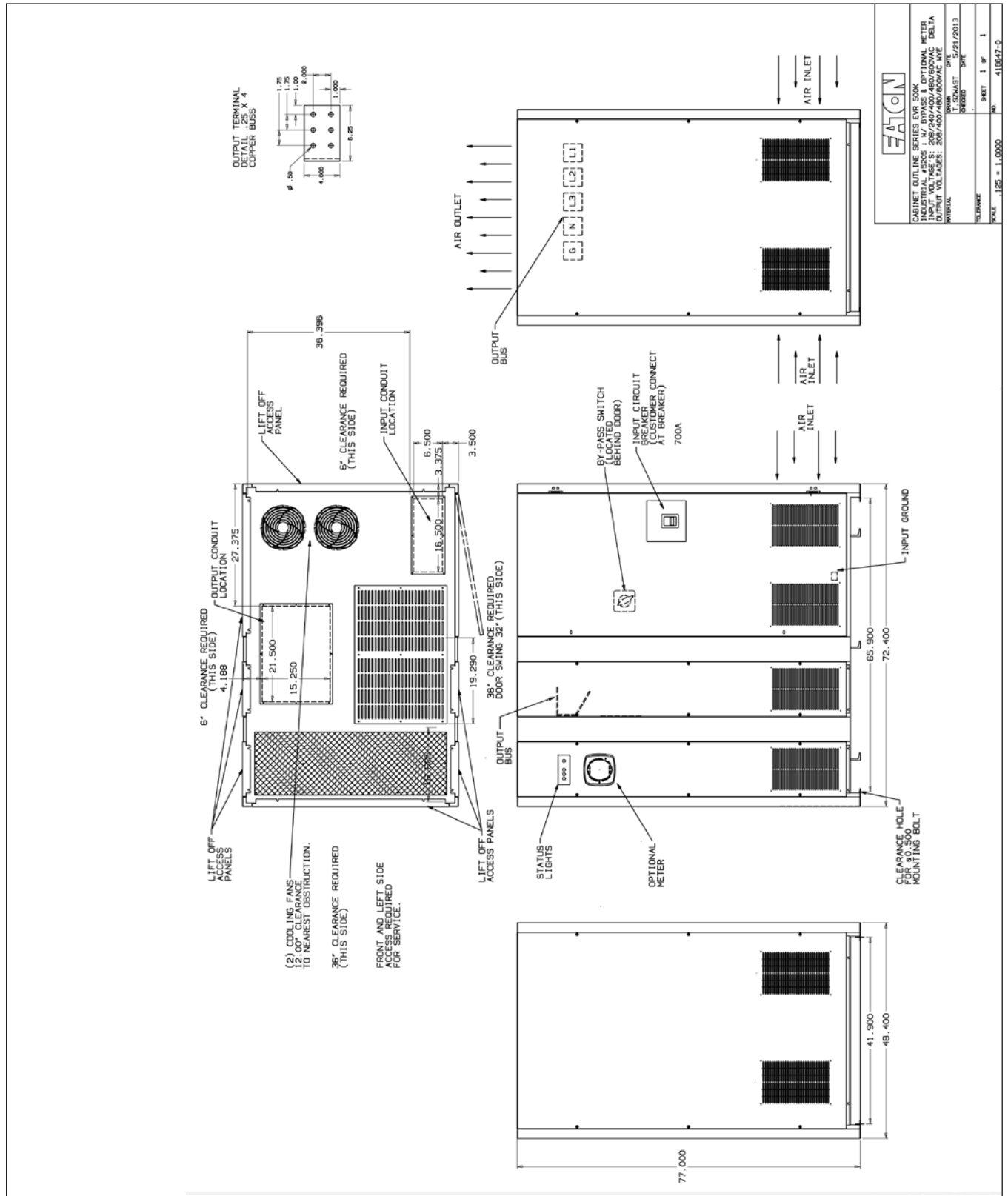

Figure 27. Installation Diagram—Power-Sure 700 500K With Bypass and Optional Meter



## Cabinet dimensions

**Table 6. Power-Sure 700 Unit Cabinet Sizes**

<b>kVA Rating</b>	<b>Bypass</b>	<b>Metering</b>	<b>Cabinet Size H x W x D (in)</b>	<b>BTUs/Hr</b>	<b>Weight (Lb)</b>
10	Yes	No	30.2 x 22.2 x 29.0	1,025	440
10	Yes	Yes	44.2 x 22.2 x 29.0	1,205	520
15	Yes	No	30.2 x 22.2 x 29.0	1,540	465
15	Yes	Yes	44.2 x 22.2 x 29.0	1,540	700
25	Yes	Yes	44.2 x 22.2 x 29.0	2,560	700
30	Yes	Yes	44.2 x 22.2 x 29.0	3,090	720
45	Yes	Yes	44.3 x 45.9 x 29.0	4,600	950
50	Yes	Yes	66.0 x 29.0 x 35.5	7,332	1,176
75	Yes	Yes	76.0 x 34.4 x 35.5	9,514	1,575
100	Yes	Yes	76.0 x 34.4 x 35.5	11,833	2,014
125	Yes	Yes	76.0 x 34.4 x 35.5	14,748	2,137
150	Yes	Yes	76.0 x 34.4 x 35.5	17,698	2,240
225	Yes	Yes	77.4 x 56.0 x 41.5	23,000	3,300
300	Yes	Yes	77.4 x 56.0 x 41.5	30,750	4,000
500	Yes	Yes	77.0 x 72.4 x 48.4	51,250	5,500

### Manual bypass switch

The manual bypass switch is a break-before-make switch located on the Power-Sure 700. The manual bypass switch is used to bypass all power electronics in case of failure. Bypass is standard on 50 kVA and larger units and an option on 45 kVA and smaller units.

**Note:** This switch may be added in the field.

### Normal mode

With the switch in the normal position, the Power-Sure 700 will provide clean and regulated power to the critical loads. The Power-Sure 700 should have the switch in the normal position unless a failure has occurred.

These units are sold in accordance to Eaton Selling Policy 25-000.



## Bypass mode

With the switch in the bypass position, the Power-Sure 700 will provide clean power to the critical loads. In the bypass position, the unit will not regulate the incoming voltage. The transformer and suppression circuitry remains in the circuit when in the bypass mode. The Power-Sure 700 should be placed in the bypass position when a failure of the system has occurred. This provides the user with some protection until a service technician arrives.

---

### CAUTION

---

Prior to switching from one position to another, turn off the AC input breaker. Some systems are equipped with push-to-turn switches. With these switches, the switch will shunt trip the input breaker when pressed in.

## Standard monitoring

Overtemp sensing devices are mounted at critical points on the SCR regulating assembly and the main transformer. If an overtemp condition exists, the unit will electronically shut off; however, the cooling fans will continue to operate. The "ALERT" light will illuminate and hold until the overtemp is corrected. The main AC input breaker must be turned off in order to reset the "ALERT" light.

**Alert light**—An indicator light indicates if the output has been disabled by one of the following conditions:

- (1) Transformer over-temperature
- (2) SCR thermal over-temperature

**Indicating lamps**—Output ON indicating lamps are provided for each phase.

## Metering option

The Power-Sure 700 offers two metering options. The IQ 130 meter is the standard option on the Power-Sure 700. The IQ 130 has programmable voltage, current transformer ratios, and true rms indication for accurate measurement of distorted waveforms, which can be viewed through four screens via a high visibility LED display. Installation and operation instructions for this meter can be found in Instructional Leaflet IL02601002E. The premium metering option is the IQ 150—which offers all the features of the IQ 130, along with energy, power, communications ability, and many other enhanced features. Please refer to Technical Data TD02601025E for additional information.

## Warranty

Eaton warrants the Power-Sure 700 to be free from defects in material and workmanship for a period of one year from the shipment date. The warranty includes parts only during this time.

These units are sold in accordance to Eaton Selling Policy 25-000.

# Warranty

**Figure 28. Performance Checklist**

Company \_\_\_\_\_

Model # \_\_\_\_\_ Serial # \_\_\_\_\_

1. Customer Comments or Problems \_\_\_\_\_
2. Power Processor Environment Clean and Dust Free Yes \_\_\_\_\_ No \_\_\_\_\_
3. Phase Rotation Correct (ABC) Yes \_\_\_\_\_ No \_\_\_\_\_
4. Electrically wired properly ie...Conductor Sizing, Breakers, Grounding
5. Verify Input Voltage (See specification tag)
6. Check Tightness of Electrical Connections:
 

\_\_\_\_\_ Input Connections \_\_\_\_\_ Output Connections \_\_\_\_\_ Heatsink Connections (SCR's)

\_\_\_\_\_ Circuit Board Connections \_\_\_\_\_ By-Pass Switch \_\_\_\_\_ Fuse Connections

\_\_\_\_\_ Fan Connections \_\_\_\_\_ Transformer Connections
7. Exercise all circuit breakers-
 

\_\_\_\_\_ Input Breaker \_\_\_\_\_ Output Breakers
8. Input/Output Voltage Checks (Adjust as Needed).
 

<u>No Load Input</u>		<u>No Load Output</u>	
A-B _____ VAC _____	A-N _____ VAC _____	A-B _____ VAC _____	
B-C _____ VAC _____	B-N _____ VAC _____	B-C _____ VAC _____	
A-C _____ VAC _____	C-N _____ VAC _____	A-C _____ VAC _____	
9. Available Load Input

A-B _____ VAC _____	A-N _____ VAC _____	A-B _____ VAC _____
B-C _____ VAC _____	B-N _____ VAC _____	B-C _____ VAC _____
A-C _____ VAC _____	C-N _____ VAC _____	A-C _____ VAC _____
10. Input/Output Current Checks (Balance as Needed).
 

<u>Input</u>	<u>Output</u>
A _____ Amps	A _____ Amps
B _____ Amps	B _____ Amps
C _____ Amps	C _____ Amps
	N _____ Amps
	G _____ Amps
11. Fans Operational \_\_\_\_\_



Eaton is dedicated to ensuring that reliable, efficient and safe power is available when it's needed most. With unparalleled knowledge of electrical power management across industries, experts at Eaton deliver customized, integrated solutions to solve our customers' most critical challenges.

Our focus is on delivering the right solution for the application. But, decision makers demand more than just innovative products. They turn to Eaton for an unwavering commitment to personal support that makes customer success a top priority. For more information, **visit [www.powerquality.eaton.com](http://www.powerquality.eaton.com)**.

**Eaton**  
1000 Eaton Boulevard  
Cleveland, OH 44122  
United States  
[Eaton.com](http://Eaton.com)

© 2013 Eaton  
All Rights Reserved  
Printed in USA  
Publication No. IM1002004E / Z14144  
September 2013

Eaton is a registered trademark.

All trademarks are property  
of their respective owners.

**EATON**  
*Powering Business Worldwide*