

HP ProLiant DL/ML370 G6 Server Maintenance and Service Guide



Part Number 513481-004
October 2010 (Fourth Edition)

© Copyright 2009, 2010 Hewlett-Packard Development Company, L.P.

The information contained herein is subject to change without notice. The only warranties for HP products and services are set forth in the express warranty statements accompanying such products and services. Nothing herein should be construed as constituting an additional warranty. HP shall not be liable for technical or editorial errors or omissions contained herein.

Microsoft, Windows, and Windows Server are U.S. registered trademarks of Microsoft Corporation.

Intel and Xeon are trademarks or registered trademarks of Intel Corporation or its subsidiaries in the United States and other countries.

Intended audience

This guide is for an experienced service technician. HP assumes you are qualified in the servicing of computer equipment and trained in recognizing hazards in products with hazardous energy levels and are familiar with weight and stability precautions for rack installations.

Contents

Customer self repair	6
Parts only warranty service	6
Illustrated parts catalog	17
Mechanical components.....	17
System components	21
Removal and replacement procedures	27
Required tools.....	27
Safety considerations.....	27
Preventing electrostatic discharge	27
Symbols on equipment	27
Rack warnings	28
Preparation procedures.....	29
Power down the server	29
Remove the server from the rack	29
Extend the server from the rack.....	30
Access the product rear panel.....	31
Tower bezel	32
Access panel	33
Fan 5	33
Cache module	34
BBWC battery pack or FBWC capacitor pack.....	35
Air baffle	36
Remove the fan cage	37
Fan blank.....	38
Fans 1-4.....	39
Tower side panels	40
Feet.....	42
SAS hard drive blank.....	43
SAS/SATA hard drive.....	43
Media bay blank	44
DVD-ROM drive	44
Slimline optical drive	45
Hard drive cage blank.....	46
Hard drive cages and backplanes	47
Two-bay LFF drive cage.....	47
Six-bay LFF backplane.....	49
Eight-bay SFF drive cage backplane (bay 1)	50
Eight-bay SFF drive cage backplane (bay 2)	51
Eight-bay SFF drive cage backplane (bay 3)	53
Power supply	54
Heatsink.....	55
Processor	57
DIMMs.....	62
PCIe expansion board	63
HP NC375i adapter	64

HP NC524SFP Dual Port 10GbE Module	66
Systems Insight Display	67
Systems Insight Display cables	68
I/O bezel.....	69
I/O bezel cables.....	69
Battery	70
HP Trusted Platform Module	71
System board	71
Power supply backplane	77
Cabling	79
Storage device cabling guidelines	79
Eight-bay SFF drive cage cabling	79
Six-bay LFF backplane cabling	81
Two-bay LFF drive cage cabling	82
BBWC battery pack and FBWC capacitor pack cabling.....	83
DVD-ROM drive cabling.....	83
Slimline optical drive cabling	84
Diagnostic tools	85
Troubleshooting resources	85
HP Insight Diagnostics.....	85
HP Insight Diagnostics survey functionality	85
Integrated Management Log	86
HP Insight Remote Support software	86
USB support	87
Component identification.....	88
Front panel components	88
Front panel LEDs and buttons	89
Systems Insight Display LEDs.....	90
Systems Insight Display LED combinations.....	90
Rear panel components.....	92
Rear panel LEDs.....	93
System board components.....	94
DIMM slots	95
DIMM identification	95
System maintenance switch.....	96
NMI functionality.....	97
SAS and SATA device numbers.....	98
SAS and SATA hard drive LEDs.....	99
SAS and SATA hard drive LED combinations	99
Fans	100
Battery pack LEDs.....	101
FBWC module LEDs.....	103
Power supply backplane connectors	103
Drive cage jumper location and configuration settings.....	104
Specifications.....	106
Environmental specifications	106
Server specifications	106
Power supply specifications	107
Acronyms and abbreviations.....	109

Index..... 111

Customer self repair

HP products are designed with many Customer Self Repair (CSR) parts to minimize repair time and allow for greater flexibility in performing defective parts replacement. If during the diagnosis period HP (or HP service providers or service partners) identifies that the repair can be accomplished by the use of a CSR part, HP will ship that part directly to you for replacement. There are two categories of CSR parts:

- **Mandatory**—Parts for which customer self repair is mandatory. If you request HP to replace these parts, you will be charged for the travel and labor costs of this service.
- **Optional**—Parts for which customer self repair is optional. These parts are also designed for customer self repair. If, however, you require that HP replace them for you, there may or may not be additional charges, depending on the type of warranty service designated for your product.

NOTE: Some HP parts are not designed for customer self repair. In order to satisfy the customer warranty, HP requires that an authorized service provider replace the part. These parts are identified as "No" in the Illustrated Parts Catalog.

Based on availability and where geography permits, CSR parts will be shipped for next business day delivery. Same day or four-hour delivery may be offered at an additional charge where geography permits. If assistance is required, you can call the HP Technical Support Center and a technician will help you over the telephone. HP specifies in the materials shipped with a replacement CSR part whether a defective part must be returned to HP. In cases where it is required to return the defective part to HP, you must ship the defective part back to HP within a defined period of time, normally five (5) business days. The defective part must be returned with the associated documentation in the provided shipping material. Failure to return the defective part may result in HP billing you for the replacement. With a customer self repair, HP will pay all shipping and part return costs and determine the courier/carrier to be used.

For more information about HP's Customer Self Repair program, contact your local service provider. For the North American program, refer to the HP website (<http://www.hp.com/go/selfrepair>).

Parts only warranty service

Your HP Limited Warranty may include a parts only warranty service. Under the terms of parts only warranty service, HP will provide replacement parts free of charge.

For parts only warranty service, CSR part replacement is mandatory. If you request HP to replace these parts, you will be charged for the travel and labor costs of this service.

Réparation par le client (CSR)

Les produits HP comportent de nombreuses pièces CSR (Customer Self Repair = réparation par le client) afin de minimiser les délais de réparation et faciliter le remplacement des pièces défectueuses. Si pendant la période de diagnostic, HP (ou ses partenaires ou mainteneurs agréés) détermine que la réparation peut être effectuée à l'aide d'une pièce CSR, HP vous l'envoie directement. Il existe deux catégories de pièces CSR:

Obligatoire - Pièces pour lesquelles la réparation par le client est obligatoire. Si vous demandez à HP de remplacer ces pièces, les coûts de déplacement et main d'œuvre du service vous seront facturés.

Facultatif - Pièces pour lesquelles la réparation par le client est facultative. Ces pièces sont également conçues pour permettre au client d'effectuer lui-même la réparation. Toutefois, si vous demandez à HP de remplacer ces pièces, l'intervention peut ou non vous être facturée, selon le type de garantie applicable à votre produit.

REMARQUE: Certaines pièces HP ne sont pas conçues pour permettre au client d'effectuer lui-même la réparation. Pour que la garantie puisse s'appliquer, HP exige que le remplacement de la pièce soit effectué par un Mainteneur Agréé. Ces pièces sont identifiées par la mention "Non" dans le Catalogue illustré.

Les pièces CSR sont livrées le jour ouvré suivant, dans la limite des stocks disponibles et selon votre situation géographique. Si votre situation géographique le permet et que vous demandez une livraison le jour même ou dans les 4 heures, celle-ci vous sera facturée. Pour bénéficier d'une assistance téléphonique, appelez le Centre d'assistance technique HP. Dans les documents envoyés avec la pièce de rechange CSR, HP précise s'il est nécessaire de lui retourner la pièce défectueuse. Si c'est le cas, vous devez le faire dans le délai indiqué, généralement cinq (5) jours ouvrés. La pièce et sa documentation doivent être retournées dans l'emballage fourni. Si vous ne retournez pas la pièce défectueuse, HP se réserve le droit de vous facturer les coûts de remplacement. Dans le cas d'une pièce CSR, HP supporte l'ensemble des frais d'expédition et de retour, et détermine la société de courses ou le transporteur à utiliser.

Pour plus d'informations sur le programme CSR de HP, contactez votre Mainteneur Agréé local. Pour plus d'informations sur ce programme en Amérique du Nord, consultez le site Web HP (<http://www.hp.com/go/selfrepair>).

Service de garantie "pièces seules"

Votre garantie limitée HP peut inclure un service de garantie "pièces seules". Dans ce cas, les pièces de rechange fournies par HP ne sont pas facturées.

Dans le cadre de ce service, la réparation des pièces CSR par le client est obligatoire. Si vous demandez à HP de remplacer ces pièces, les coûts de déplacement et main d'œuvre du service vous seront facturés.

Riparazione da parte del cliente

Per abbreviare i tempi di riparazione e garantire una maggiore flessibilità nella sostituzione di parti difettose, i prodotti HP sono realizzati con numerosi componenti che possono essere riparati direttamente dal cliente (CSR, Customer Self Repair). Se in fase di diagnostica HP (o un centro di servizi o di assistenza HP) identifica il guasto come riparabile mediante un ricambio CSR, HP lo spedisce direttamente al cliente per la sostituzione. Vi sono due categorie di parti CSR:

Obbligatorie – Parti che devono essere necessariamente riparate dal cliente. Se il cliente ne affida la riparazione ad HP, deve sostenere le spese di spedizione e di manodopera per il servizio.

Opzionali – Parti la cui riparazione da parte del cliente è facoltativa. Si tratta comunque di componenti progettati per questo scopo. Se tuttavia il cliente ne richiede la sostituzione ad HP, potrebbe dover sostenere spese addizionali a seconda del tipo di garanzia previsto per il prodotto.

NOTA: alcuni componenti HP non sono progettati per la riparazione da parte del cliente. Per rispettare la garanzia, HP richiede che queste parti siano sostituite da un centro di assistenza autorizzato. Tali parti sono identificate da un "No" nel Catalogo illustrato dei componenti.

In base alla disponibilità e alla località geografica, le parti CSR vengono spedite con consegna entro il giorno lavorativo seguente. La consegna nel giorno stesso o entro quattro ore è offerta con un supplemento di costo solo in alcune zone. In caso di necessità si può richiedere l'assistenza telefonica di un addetto del centro di supporto tecnico HP. Nel materiale fornito con una parte di ricambio CSR, HP specifica se il cliente deve restituire dei componenti. Qualora sia richiesta la resa ad HP del componente difettoso, lo si deve spedire ad HP entro un determinato periodo di tempo, generalmente cinque (5) giorni lavorativi. Il componente difettoso deve essere restituito con la documentazione associata nell'imballo di spedizione fornito. La mancata restituzione del componente può comportare la fatturazione del ricambio da parte di HP. Nel caso di riparazione da parte del cliente, HP sostiene tutte le spese di spedizione e resa e sceglie il corriere/vettore da utilizzare.

Per ulteriori informazioni sul programma CSR di HP contattare il centro di assistenza di zona. Per il programma in Nord America fare riferimento al sito Web HP (<http://www.hp.com/go/selfrepair>).

Servizio di garanzia per i soli componenti

La garanzia limitata HP può includere un servizio di garanzia per i soli componenti. Nei termini di garanzia del servizio per i soli componenti, HP fornirà gratuitamente le parti di ricambio.

Per il servizio di garanzia per i soli componenti è obbligatoria la formula CSR che prevede la riparazione da parte del cliente. Se il cliente invece richiede la sostituzione ad HP, dovrà sostenere le spese di spedizione e di manodopera per il servizio.

Customer Self Repair

HP Produkte enthalten viele CSR-Teile (Customer Self Repair), um Reparaturzeiten zu minimieren und höhere Flexibilität beim Austausch defekter Bauteile zu ermöglichen. Wenn HP (oder ein HP Servicepartner) bei der Diagnose feststellt, dass das Produkt mithilfe eines CSR-Teils repariert werden kann, sendet Ihnen HP dieses Bauteil zum Austausch direkt zu. CSR-Teile werden in zwei Kategorien unterteilt:

Zwingend – Teile, für die das Customer Self Repair-Verfahren zwingend vorgegeben ist. Wenn Sie den Austausch dieser Teile von HP vornehmen lassen, werden Ihnen die Anfahrt- und Arbeitskosten für diesen Service berechnet.

Optional – Teile, für die das Customer Self Repair-Verfahren optional ist. Diese Teile sind auch für Customer Self Repair ausgelegt. Wenn Sie jedoch den Austausch dieser Teile von HP vornehmen lassen möchten, können bei diesem Service je nach den für Ihr Produkt vorgesehenen Garantiebedingungen zusätzliche Kosten anfallen.

HINWEIS: Einige Teile sind nicht für Customer Self Repair ausgelegt. Um den Garantieanspruch des Kunden zu erfüllen, muss das Teil von einem HP Servicepartner ersetzt werden. Im illustrierten Teilekatalog sind diese Teile mit „No“ bzw. „Nein“ gekennzeichnet.

CSR-Teile werden abhängig von der Verfügbarkeit und vom Lieferziel am folgenden Geschäftstag geliefert. Für bestimmte Standorte ist eine Lieferung am selben Tag oder innerhalb von vier Stunden gegen einen Aufpreis verfügbar. Wenn Sie Hilfe benötigen, können Sie das HP technische Support Center

anrufen und sich von einem Mitarbeiter per Telefon helfen lassen. Den Materialien, die mit einem CSR-Ersatzteil geliefert werden, können Sie entnehmen, ob das defekte Teil an HP zurückgeschickt werden muss. Wenn es erforderlich ist, das defekte Teil an HP zurückzuschicken, müssen Sie dies innerhalb eines vorgegebenen Zeitraums tun, in der Regel innerhalb von fünf (5) Geschäftstagen. Das defekte Teil muss mit der zugehörigen Dokumentation in der Verpackung zurückgeschickt werden, die im Lieferumfang enthalten ist. Wenn Sie das defekte Teil nicht zurückschicken, kann HP Ihnen das Ersatzteil in Rechnung stellen. Im Falle von Customer Self Repair kommt HP für alle Kosten für die Lieferung und Rücksendung auf und bestimmt den Kurier-/Frachtdienst.

Weitere Informationen über das HP Customer Self Repair Programm erhalten Sie von Ihrem Servicepartner vor Ort. Informationen über das CSR-Programm in Nordamerika finden Sie auf der HP Website unter (<http://www.hp.com/go/selfrepair>).

Parts-only Warranty Service (Garantieservice ausschließlich für Teile)

Ihre HP Garantie umfasst möglicherweise einen Parts-only Warranty Service (Garantieservice ausschließlich für Teile). Gemäß den Bestimmungen des Parts-only Warranty Service stellt HP Ersatzteile kostenlos zur Verfügung.

Für den Parts-only Warranty Service ist das CSR-Verfahren zwingend vorgegeben. Wenn Sie den Austausch dieser Teile von HP vornehmen lassen, werden Ihnen die Anfahrt- und Arbeitskosten für diesen Service berechnet.

Reparaciones del propio cliente

Los productos de HP incluyen muchos componentes que el propio usuario puede reemplazar (*Customer Self Repair*, CSR) para minimizar el tiempo de reparación y ofrecer una mayor flexibilidad a la hora de realizar sustituciones de componentes defectuosos. Si, durante la fase de diagnóstico, HP (o los proveedores o socios de servicio de HP) identifica que una reparación puede llevarse a cabo mediante el uso de un componente CSR, HP le enviará dicho componente directamente para que realice su sustitución. Los componentes CSR se clasifican en dos categorías:

- **Obligatorio:** componentes para los que la reparación por parte del usuario es obligatoria. Si solicita a HP que realice la sustitución de estos componentes, tendrá que hacerse cargo de los gastos de desplazamiento y de mano de obra de dicho servicio.
- **Opcional:** componentes para los que la reparación por parte del usuario es opcional. Estos componentes también están diseñados para que puedan ser reparados por el usuario. Sin embargo, si precisa que HP realice su sustitución, puede o no conllevar costes adicionales, dependiendo del tipo de servicio de garantía correspondiente al producto.

NOTA: Algunos componentes no están diseñados para que puedan ser reparados por el usuario. Para que el usuario haga valer su garantía, HP pone como condición que un proveedor de servicios autorizado realice la sustitución de estos componentes. Dichos componentes se identifican con la palabra "No" en el catálogo ilustrado de componentes.

Según la disponibilidad y la situación geográfica, los componentes CSR se enviarán para que lleguen a su destino al siguiente día laborable. Si la situación geográfica lo permite, se puede solicitar la entrega en el mismo día o en cuatro horas con un coste adicional. Si precisa asistencia técnica, puede llamar al

Centro de asistencia técnica de HP y recibirá ayuda telefónica por parte de un técnico. Con el envío de materiales para la sustitución de componentes CSR, HP especificará si los componentes defectuosos deberán devolverse a HP. En aquellos casos en los que sea necesario devolver algún componente a HP, deberá hacerlo en el periodo de tiempo especificado, normalmente cinco días laborables. Los componentes defectuosos deberán devolverse con toda la documentación relacionada y con el embalaje de envío. Si no enviara el componente defectuoso requerido, HP podrá cobrarle por el de sustitución. En el caso de todas sustituciones que lleve a cabo el cliente, HP se hará cargo de todos los gastos de envío y devolución de componentes y escogerá la empresa de transporte que se utilice para dicho servicio.

Para obtener más información acerca del programa de Reparaciones del propio cliente de HP, póngase en contacto con su proveedor de servicios local. Si está interesado en el programa para Norteamérica, visite la página web de HP siguiente (<http://www.hp.com/go/selfrepair>).

Servicio de garantía exclusivo de componentes

La garantía limitada de HP puede que incluya un servicio de garantía exclusivo de componentes. Según las condiciones de este servicio exclusivo de componentes, HP le facilitará los componentes de repuesto sin cargo adicional alguno.

Para este servicio de garantía exclusivo de componentes, es obligatoria la sustitución de componentes por parte del usuario (CSR). Si solicita a HP que realice la sustitución de estos componentes, tendrá que hacerse cargo de los gastos de desplazamiento y de mano de obra de dicho servicio.

Customer Self Repair

Veel onderdelen in HP producten zijn door de klant zelf te repareren, waardoor de reparatieduur tot een minimum beperkt kan blijven en de flexibiliteit in het vervangen van defecte onderdelen groter is. Deze onderdelen worden CSR-onderdelen (Customer Self Repair) genoemd. Als HP (of een HP Service Partner) bij de diagnose vaststelt dat de reparatie kan worden uitgevoerd met een CSR-onderdeel, verzendt HP dat onderdeel rechtstreeks naar u, zodat u het defecte onderdeel daarmee kunt vervangen. Er zijn twee categorieën CSR-onderdelen:

Verplicht: Onderdelen waarvoor reparatie door de klant verplicht is. Als u HP verzoekt deze onderdelen voor u te vervangen, worden u voor deze service reiskosten en arbeidsloon in rekening gebracht.

Optioneel: Onderdelen waarvoor reparatie door de klant optioneel is. Ook deze onderdelen zijn ontworpen voor reparatie door de klant. Als u echter HP verzoekt deze onderdelen voor u te vervangen, kunnen daarvoor extra kosten in rekening worden gebracht, afhankelijk van het type garantieservice voor het product.

OPMERKING: Sommige HP onderdelen zijn niet ontwikkeld voor reparatie door de klant. In verband met de garantievoorwaarden moet het onderdeel door een geautoriseerde Service Partner worden vervangen. Deze onderdelen worden in de geïllustreerde onderdelencatalogus aangemerkt met "Nee".

Afhankelijk van de leverbaarheid en de locatie worden CSR-onderdelen verzonden voor levering op de eerstvolgende werkdag. Levering op dezelfde dag of binnen vier uur kan tegen meerkosten worden aangeboden, indien dit mogelijk is gezien de locatie. Indien assistentie gewenst is, belt u een HP Service Partner om via de telefoon technische ondersteuning te ontvangen. HP vermeldt in de documentatie bij het vervangende CSR-onderdeel of het defecte onderdeel aan HP moet worden geretourneerd. Als het defecte onderdeel aan HP moet worden teruggezonden, moet u het defecte onderdeel binnen een bepaalde periode, gewoonlijk vijf (5) werkdagen, retourneren aan HP. Het defecte onderdeel moet met de

bijbehorende documentatie worden geretourneerd in het meegeleverde verpakkingsmateriaal. Als u het defecte onderdeel niet terugzendt, kan HP u voor het vervangende onderdeel kosten in rekening brengen. Bij reparatie door de klant betaalt HP alle verzendkosten voor het vervangende en geretourneerde onderdeel en kiest HP zelf welke koerier/transportonderneming hiervoor wordt gebruikt.

Neem contact op met een Service Partner voor meer informatie over het Customer Self Repair programma van HP. Informatie over Service Partners vindt u op de HP website (<http://www.hp.com/go/selfrepair>).

Garantieservice "Parts Only"

Het is mogelijk dat de HP garantie alleen de garantieservice "Parts Only" omvat. Volgens de bepalingen van de Parts Only garantieservice zal HP kosteloos vervangende onderdelen ter beschikking stellen.

Voor de Parts Only garantieservice is vervanging door CSR-onderdelen verplicht. Als u HP verzoekt deze onderdelen voor u te vervangen, worden u voor deze service reiskosten en arbeidsloon in rekening gebracht.

Reparo feito pelo cliente

Os produtos da HP são projetados com muitas peças para reparo feito pelo cliente (CSR) de modo a minimizar o tempo de reparo e permitir maior flexibilidade na substituição de peças com defeito. Se, durante o período de diagnóstico, a HP (ou fornecedores/parceiros de serviço da HP) concluir que o reparo pode ser efetuado pelo uso de uma peça CSR, a peça de reposição será enviada diretamente ao cliente. Existem duas categorias de peças CSR:

Obrigatória – Peças cujo reparo feito pelo cliente é obrigatório. Se desejar que a HP substitua essas peças, serão cobradas as despesas de transporte e mão-de-obra do serviço.

Opcional – Peças cujo reparo feito pelo cliente é opcional. Essas peças também são projetadas para o reparo feito pelo cliente. No entanto, se desejar que a HP as substitua, pode haver ou não a cobrança de taxa adicional, dependendo do tipo de serviço de garantia destinado ao produto.

OBSERVAÇÃO: Algumas peças da HP não são projetadas para o reparo feito pelo cliente. A fim de cumprir a garantia do cliente, a HP exige que um técnico autorizado substitua a peça. Essas peças estão identificadas com a marca "No" (Não), no catálogo de peças ilustrado.

Conforme a disponibilidade e o local geográfico, as peças CSR serão enviadas no primeiro dia útil após o pedido. Onde as condições geográficas permitirem, a entrega no mesmo dia ou em quatro horas pode ser feita mediante uma taxa adicional. Se precisar de auxílio, entre em contato com o Centro de suporte técnico da HP para que um técnico o ajude por telefone. A HP especifica nos materiais fornecidos com a peça CSR de reposição se a peça com defeito deve ser devolvida à HP. Nos casos em que isso for necessário, é preciso enviar a peça com defeito à HP dentro do período determinado, normalmente cinco (5) dias úteis. A peça com defeito deve ser enviada com a documentação correspondente no material de transporte fornecido. Caso não o faça, a HP poderá cobrar a reposição. Para as peças de reparo feito pelo cliente, a HP paga todas as despesas de transporte e de devolução da peça e determina a transportadora/serviço postal a ser utilizado.

Para obter mais informações sobre o programa de reparo feito pelo cliente da HP, entre em contato com o fornecedor de serviços local. Para o programa norte-americano, visite o site da HP (<http://www.hp.com/go/selfrepair>).

Serviço de garantia apenas para peças

A garantia limitada da HP pode incluir um serviço de garantia apenas para peças. Segundo os termos do serviço de garantia apenas para peças, a HP fornece as peças de reposição sem cobrar nenhuma taxa.

No caso desse serviço, a substituição de peças CSR é obrigatória. Se desejar que a HP substitua essas peças, serão cobradas as despesas de transporte e mão-de-obra do serviço.

顧客自己修理保証サービス

修理時間を短縮し、故障部品の交換における高い柔軟性を確保するために、HP製品には多数の顧客自己修理（CSR）部品があります。診断の際に、CSR部品を使用すれば修理ができるとHP（HPまたはHP正規保守代理店）が判断した場合、HPはその部品を直接、お客様に発送し、お客様に交換していただきます。CSR部品には以下の2通りがあります。

- 必須 - 顧客自己修理が必須の部品。当該部品について、もしもお客様がHPに交換作業を依頼される場合には、その修理サービスに関する交通費および人件費がお客様に請求されます。
- 任意 - 顧客自己修理が任意である部品。この部品も顧客自己修理用です。当該部品について、もしもお客様がHPに交換作業を依頼される場合には、お買い上げの製品に適用される保証サービス内容の範囲内においては、別途費用を負担していただくことなく保証サービスを受けることができます。

注： HP製品の一部の部品は、顧客自己修理用ではありません。製品の保証を継続するためには、HPまたはHP正規保守代理店による交換作業が必須となります。部品カタログには、当該部品が顧客自己修理除外品である旨が記載されています。

部品供給が可能な場合、地域によっては、CSR部品を翌営業日に届くように発送します。また、地域によっては、追加費用を負担いただくことにより同日または4時間以内に届くように発送することも可能な場合があります。サポートが必要なときは、HPの修理受付窓口にご連絡いただければ、技術者が電話でアドバイスします。交換用のCSR部品または同梱物には、故障部品をHPに返送する必要があるかどうかが表示されています。故障部品をHPに返送する必要がある場合は、指定期限内（通常は5営業日以内）に故障部品をHPに返送してください。故障部品を返送する場合は、届いた時の梱包箱に関連書類とともに入れてください。故障部品を返送しない場合、HPから部品費用が請求されます。顧客自己修理の際には、HPは送料および部品返送費を全額負担し、使用する宅配便会社や運送会社を指定します。

部品のみ保証サービス

HP保証サービスには、部品のみ保証サービスが適用される場合があります。このサービスでは、交換部品は無償で提供されます。

部品のみ保証サービスにおいては、CSR部品をお客様により交換作業していただくことが必須となります。当該部品について、もしもお客様がHPに交換作業を依頼される場合には、その修理サービスに関する交通費および人件費はお客様の負担となります。

客户自行维修

HP 产品提供许多客户自行维修 (CSR) 部件，以尽可能缩短维修时间和在更换缺陷部件方面提供更大的灵活性。如果在诊断期间 HP（或 HP 服务提供商或服务合作伙伴）确定可以通过使用 CSR 部件完成维修，HP 将直接把该部件发送给您进行更换。有两类 CSR 部件：

- **强制性的** — 要求客户必须自行维修的部件。如果您请求 HP 更换这些部件，则必须为该服务支付差旅费和人工费用。
- **可选的** — 客户可以选择是否自行维修的部件。这些部件也是为客户自行维修设计的。不过，如果您要求 HP 为您更换这些部件，则根据为您的产品指定的保修服务类型，HP 可能收取或不再收取任何附加费用。

注：某些 HP 部件的设计并未考虑客户自行维修。为了满足客户保修的需要，HP 要求授权服务提供商更换相关部件。这些部件在部件图解目录中标记为“否”。

CSR 部件将在下一个工作日发运（取决于备货情况和允许的地理范围）。在允许的地理范围内，可在当天或四小时内发运，但要收取额外费用。如果需要帮助，您可以致电 HP 技术支持中心，将会有技术人员通过电话为您提供帮助。HP 会在随更换的 CSR 部件发运的材料中指明是否必须将有缺陷的部件返还给 HP。如果要求您将有缺陷的部件返还给 HP，那么您必须在规定期限内（通常是五 (5) 个工作日）将缺陷部件发给 HP。有缺陷的部件必须随所提供的发运材料中的相关文件一起返还。如果未能送还有缺陷的部件，HP 可能会要求您支付更换费用。客户自行维修时，HP 将承担所有相关运输和部件返回费用，并指定快递商/承运商。

有关 HP 客户自行维修计划的详细信息，请与您当地的服务提供商联系。有关北美地区的计划，请访问 HP 网站 (<http://www.hp.com/go/selfrepair>)。

仅部件保修服务

您的 HP 有限保修服务可能涉及仅部件保修服务。根据仅部件保修服务条款的规定，HP 将免费提供更换的部件。

仅部件保修服务要求进行 CSR 部件更换。如果您请求 HP 更换这些部件，则必须为该服务支付差旅费和人工费用。

客戶自行維修

HP 產品設計了許多「客戶自行維修」(CSR) 的零件以減少維修時間，並且使得更換瑕疵零件時能有更大的彈性。如果在診斷期間 HP（或 HP 服務供應商或維修夥伴）辨認出此項維修工作可以藉由使用 CSR 零件來完成，則 HP 將直接寄送該零件給您作更換。CSR 零件分為兩種類別：

- **強制的** — 客戶自行維修所使用的零件是強制性的。如果您要求 HP 更換這些零件，HP 將會向您收取此服務所需的外出費用與勞動成本。
- **選購的** — 客戶自行維修所使用的零件是選購的。這些零件也設計用於客戶自行維修之用。不過，如果您要求 HP 為您更換，則可能需要也可能不需要負擔額外的費用，端視針對此產品指定的保固服務類型而定。

備註：某些 HP 零件沒有消費者可自行維修的設計。為符合客戶保固，HP 需要授權的服務供應商更換零件。這些零件在圖示的零件目錄中，被標示為「否」。

基於材料取得及環境允許的情況下，CSR 零件將於下一個工作日以快遞寄送。在環境的允許下當天或四小時內送達，則可能需要額外的費用。若您需要協助，可致電「HP 技術支援中心」，會有一位技術人員透過電話來協助您。不論損壞的零件是否必須退回，HP 皆會在與 CSR 替換零件一起運送的材料中註明。若要將損壞的零件退回 HP，您必須在指定的一段時間內（通常為五 (5) 個工作天），將損壞的零件寄回 HP。損壞的零件必須與寄送資料中隨附的相關技術文件一併退還。如果無法退還損壞的零件，HP 可能要向您收取替換費用。針對客戶自行維修情形，HP 將負責所有運費及零件退還費用並指定使用何家快遞/貨運公司。

如需 HP 的「客戶自行維修」方案詳細資訊，請連絡您當地的服務供應商。至於北美方案，請參閱 HP 網站 (<http://www.hp.com/go/selfrepair>)。

僅限零件的保固服務

您的「HP 有限保固」可能包含僅限零件的保固服務。在僅限零件的保固服務情況下，HP 將免費提供替換零件。

針對僅限零件的保固服務，CSR 零件替換是強制性的。如果您要求 HP 更換這些零件，HP 將會向您收取此服務所需的外出費用與勞動成本。

고객 셀프 수리

HP 제품은 수리 시간을 최소화하고 결함이 있는 부품 교체 시 더욱 융통성을 발휘할 수 있도록 하기 위해 고객 셀프 수리(CSR) 부품을 다량 사용하여 설계되었습니다. 진단 기간 동안 HP(또는 HP 서비스 공급업체 또는 서비스 협력업체)에서 CSR 부품을 사용하여 수리가 가능하다고 판단되면 HP는 해당 부품을 바로 사용자에게 보내어 사용자가 교체할 수 있도록 합니다. CSR 부품에는 두 가지 종류가 있습니다.

- **고객 셀프 수리가 의무 사항인 필수 부품.** 사용자가 HP에 이 부품의 교체를 요청할 경우 이 서비스에 대한 출장비 및 작업비가 청구됩니다.
- **고객 셀프 수리가 선택 사항인 부품.** 이 부품들도 고객 셀프 수리가 가능하도록 설계되었습니다. 하지만 사용자가 HP에 이 부품의 교체를 요청할 경우 사용자가 구입한 제품에 해당하는 보증 서비스 유형에 따라 추가 비용 없이 교체가 가능할 수 있습니다.

참고: 일부 HP 부품은 고객 셀프 수리가 불가능하도록 설계되었습니다. HP는 만족스러운 고객 보증을 위해 공인 서비스 제공업체를 통해 부품을 교체하도록 하고 있습니다. 이러한 부품들은 Illustrated Parts Catalog에 "No"라고 표시되어 있습니다.

CSR 부품은 재고 상태와 지리적 조건이 허용하는 경우 다음 영업일 납품이 가능하도록 배송이 이루어집니다. 지리적 조건이 허용하는 경우 추가 비용이 청구되는 조건으로 당일 또는 4시간 배송이 가능할 수도 있습니다. 도움이 필요하시면 HP 기술 지원 센터로 전화하십시오. 전문 기술자가 전화로 도움을 줄 것입니다. HP는 결함이 발생한 부품을 HP로 반환해야 하는지 여부를 CSR 교체 부품과 함께 배송된 자료에 지정합니다. 결함이 발생한 부품을 HP로 반환해야 하는 경우에는 지정된 기간 내(통상 영업일 기준 5일)에 HP로 반환해야 합니다. 이 때 결함이 발생한 부품은 제공된 포장 재료에 넣어 관련 설명서와 함께 반환해야 합니다. 결함이 발생한 부품을 반환하지 않는 경우 HP가 교체 부품에 대해 비용을 청구할 수 있습니다. 고객 셀프 수리의 경우, HP는 모든 운송 및 부품 반환 비용을 부담하며 이용할 운송업체 및 택배 서비스를 결정합니다.

HP 고객 셀프 수리 프로그램에 대한 자세한 내용은 가까운 서비스 제공업체에 문의하십시오. 북미 지역의 프로그램에 대해서는 HP 웹 사이트(<http://www.hp.com/go/selfrepair>)를 참조하십시오.

부품 제공 보증 서비스

HP 제한 보증에는 부품 제공 보증 서비스가 포함될 수 있습니다. 이러한 경우 HP는 부품 제공 보증 서비스의 조건에 따라 교체 부품만을 무료로 제공합니다.

부품 제공 보증 서비스 제공 시 CSR 부품 교체는 의무 사항입니다. 사용자가 HP에 이 부품의 교체를 요청할 경우 이 서비스에 대한 출장비 및 작업비가 청구됩니다.

Illustrated parts catalog

Mechanical components

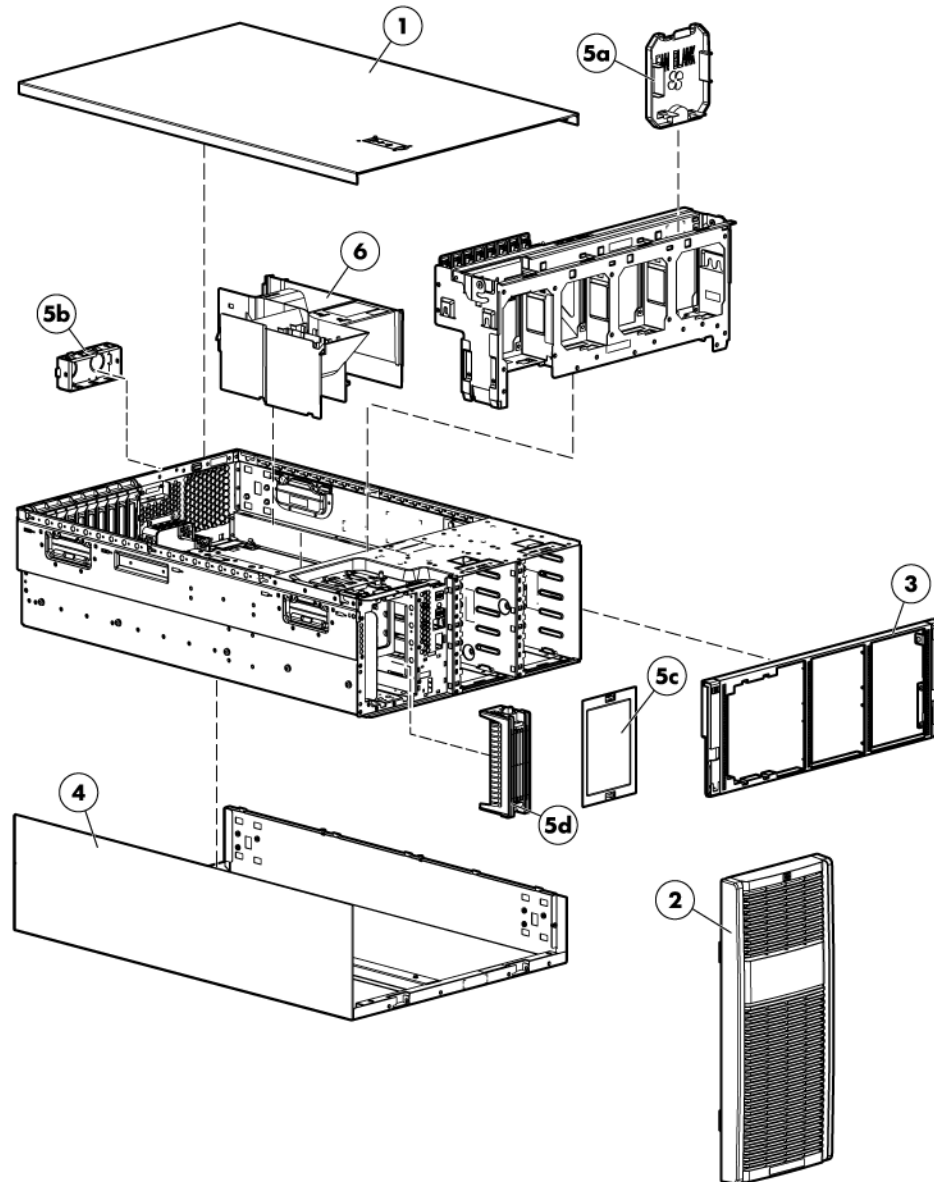

Item	Description	Spare part number	Customer self repair (on page 6)
1	Access panel	519557-001	Mandatory ¹
2	Front bezel (tower model only)	519564-001	Mandatory ¹
3	Rack bezel (rack model only)	519563-001	Mandatory ¹
4	Tower configuration panel	515048-001	Mandatory ¹

Item	Description	Spare part number	Customer self repair (on page 6)
5	Miscellaneous hardware kit	519560-001	Mandatory ¹
	a) Fan blank	—	—
	b) Power supply blank	—	—
	c) Hard drive cage blank	—	—
	d) Media bay blank	—	—
6	Air baffle	519558-001	Mandatory ¹
7	T-10/T-15 Torx screwdriver*	413965-001	Mandatory ¹
8	Tower feet*	519561-001	Mandatory ¹

*Not shown

¹Mandatory—Parts for which customer self repair is mandatory. If you request HP to replace these parts, you will be charged for the travel and labor costs of this service.

²Optional—Parts for which customer self repair is optional. These parts are also designed for customer self repair. If, however, you require that HP replace them for you, there may or may not be additional charges, depending on the type of warranty service designated for your product.

³No—Some HP parts are not designed for customer self repair. In order to satisfy the customer warranty, HP requires that an authorized service provider replace the part. These parts are identified as "No" in the Illustrated Parts Catalog.

¹Mandatory: Obligatoire—Pièces pour lesquelles la réparation par le client est obligatoire. Si vous demandez à HP de remplacer ces pièces, les coûts de déplacement et main d'œuvre du service vous seront facturés.

²Optional: Facultatif—Pièces pour lesquelles la réparation par le client est facultative. Ces pièces sont également conçues pour permettre au client d'effectuer lui-même la réparation. Toutefois, si vous demandez à HP de remplacer ces pièces, l'intervention peut ou non vous être facturée, selon le type de garantie applicable à votre produit.

³No: Non—Certaines pièces HP ne sont pas conçues pour permettre au client d'effectuer lui-même la réparation. Pour que la garantie puisse s'appliquer, HP exige que le remplacement de la pièce soit effectué par un Mainteneur Agréé. Ces pièces sont identifiées par la mention "Non" dans le Catalogue illustré.

¹Mandatory: Obbligatorie—Parti che devono essere necessariamente riparate dal cliente. Se il cliente ne affida la riparazione ad HP, deve sostenere le spese di spedizione e di manodopera per il servizio.

²Optional: Opzionali—Parti la cui riparazione da parte del cliente è facoltativa. Si tratta comunque di componenti progettati per questo scopo. Se tuttavia il cliente ne richiede la sostituzione ad HP, potrebbe dover sostenere spese addizionali a seconda del tipo di garanzia previsto per il prodotto.

³No: Non CSR—Alcuni componenti HP non sono progettati per la riparazione da parte del cliente. Per rispettare la garanzia, HP richiede che queste parti siano sostituite da un centro di assistenza autorizzato. Tali parti sono identificate da un "No" nel Catalogo illustrato dei componenti.

¹Mandatory: Zwingend—Teile, die im Rahmen des Customer Self Repair Programms ersetzt werden müssen. Wenn Sie diese Teile von HP ersetzen lassen, werden Ihnen die Versand- und Arbeitskosten für diesen Service berechnet.

²Optional: Optional—Teile, für die das Customer Self Repair-Verfahren optional ist. Diese Teile sind auch für Customer Self Repair ausgelegt. Wenn Sie jedoch den Austausch dieser Teile von HP vornehmen lassen möchten, können bei diesem Service je nach den für Ihr Produkt vorgesehenen Garantiebedingungen zusätzliche Kosten anfallen.

³No: Kein—Einige Teile sind nicht für Customer Self Repair ausgelegt. Um den Garantieanspruch des Kunden zu erfüllen, muss das Teil von einem HP Servicepartner ersetzt werden. Im illustrierten Teilekatalog sind diese Teile mit „No“ bzw. „Nein“ gekennzeichnet.

¹Mandatory: Obligatorio—componentes para los que la reparación por parte del usuario es obligatoria. Si solicita a HP que realice la sustitución de estos componentes, tendrá que hacerse cargo de los gastos de desplazamiento y de mano de obra de dicho servicio.

²Optional: Opcional— componentes para los que la reparación por parte del usuario es opcional. Estos componentes también están diseñados para que puedan ser reparados por el usuario. Sin embargo, si precisa que HP realice su sustitución, puede o no conllevar costes adicionales, dependiendo del tipo de servicio de garantía correspondiente al producto.

³No: No—Algunos componentes no están diseñados para que puedan ser reparados por el usuario. Para que el usuario haga valer su garantía, HP pone como condición que un proveedor de servicios autorizado realice la sustitución de estos componentes. Dichos componentes se identifican con la palabra "No" en el catálogo ilustrado de componentes.

¹Mandatory: Verplicht—Onderdelen waarvoor Customer Self Repair verplicht is. Als u HP verzoekt deze onderdelen te vervangen, komen de reiskosten en het arbeidsloon voor uw rekening.

²Optional: Optioneel—Onderdelen waarvoor reparatie door de klant optioneel is. Ook deze onderdelen zijn ontworpen voor reparatie door de klant. Als u echter HP verzoekt deze onderdelen voor u te vervangen, kunnen daarvoor extra kosten in rekening worden gebracht, afhankelijk van het type garanteservice voor het product.

³No: Nee—Sommige HP onderdelen zijn niet ontwikkeld voor reparatie door de klant. In verband met de garantiev voorwaarden moet het onderdeel door een geautoriseerde Service Partner worden vervangen. Deze onderdelen worden in de geïllustreerde onderdelencatalogus aangemerkt met "Nee".

¹Mandatory: Obrigatória—Peças cujo reparo feito pelo cliente é obrigatório. Se desejar que a HP substitua essas peças, serão cobradas as despesas de transporte e mão-de-obra do serviço.

²Optional: Opcional—Peças cujo reparo feito pelo cliente é opcional. Essas peças também são projetadas para o reparo feito pelo cliente. No entanto, se desejar que a HP as substitua, pode haver ou não a cobrança de taxa adicional, dependendo do tipo de serviço de garantia destinado ao produto.

³No: Nenhuma—Algumas peças da HP não são projetadas para o reparo feito pelo cliente. A fim de cumprir a garantia do cliente, a HP exige que um técnico autorizado substitua a peça. Essas peças estão identificadas com a marca "No" (Não), no catálogo de peças ilustrado.

¹Mandatory: 必須 - 顧客自己修理が必須の部品。当該部品について、もしもお客様がHPに交換作業を依頼される場合には、その修理サービスに関する交通費および人件費がお客様に請求されます。

²Optional: 任意 - 顧客自己修理が任意である部品。この部品も顧客自己修理用です。当該部品について、もしもお客様がHPに交換作業を依頼される場合には、お買い上げの製品に適用される保証サービス内容の範囲内においては、費用を負担していただくことなく保証サービスを受けることができます。

³No: 除外 - HP製品の一部の部品は、顧客自己修理用ではありません。製品の保証を継続するためには、HPまたはHP正規保守代理店による交換作業が必須となります。部品カタログには、当該部品が顧客自己修理除外品である旨が記載されています。

¹Mandatory: 強制的的 — 要求客户必须自行维修的部件。如果您请求 HP 更换这些部件，则必须为该服务支付差旅费和人工费用。

²Optional: 可选的 — 客户可以选择是否自行维修的部件。这些部件也是为客户自行维修设计的。不过，如果您要求 HP 为您更换这些部件，则根据您的产品指定的保修服务类型，HP 可能收取或不再收取任何附加费用。

³No: 否 — 某些 HP 部件的设计并未考虑客户自行维修。为了满足客户保修的需要，HP 要求授权服务提供商更换相关部件。这些部件在部件图解目录中标记为“否”。

¹Mandatory: 強制的 — 客戶自行維修所使用的零件是強制的。如果您要求 HP 更換這些零件，HP 將會向您收取此服務所需的外出費用與勞動成本。

²Optional: 選購的 — 客戶自行維修所使用的零件是選購的。這些零件也設計用於客戶自行維修之用。不過，如果您要求 HP 為您更換，則可能需要也可能不需要負擔額外的費用，端視針對此產品指定的保固服務類型而定。

³No: 否 — 某些 HP 零件沒有消費者可自行維修的設計。為符合客戶保固，HP 需要授權的服務供應商更換零件。這些零件在圖示的零件目錄中，被標示為「否」。

¹ Mandatory: 필수 — 고객 셀프 수리가 의무 사항인 필수 부품. 사용자가 HP에 이 부품의 교체를 요청할 경우 이 서비스에 대한 출장비 및 작업비가 청구됩니다.

² Optional: 옵션 — 고객 셀프 수리가 선택 사항인 부품. 이 부품들도 고객 셀프 수리가 가능하도록 설계되었습니다. 하지만 사용자가 HP에 이 부품의 교체를 요청할 경우 사용자가 구입한 제품에 해당하는 보증 서비스 유형에 따라 추가 비용 없이 교체가 가능할 수 있습니다.

³ No: No — 고객 셀프 수리가 불가능하도록 설계된 HP 부품. 이 부품들은 고객 셀프 수리가 불가능하도록 설계되었습니다. HP는 고객 보증을 만족시키기 위해 공인 서비스 제공업체를 통해 부품을 교체하도록 하고 있습니다.

System components

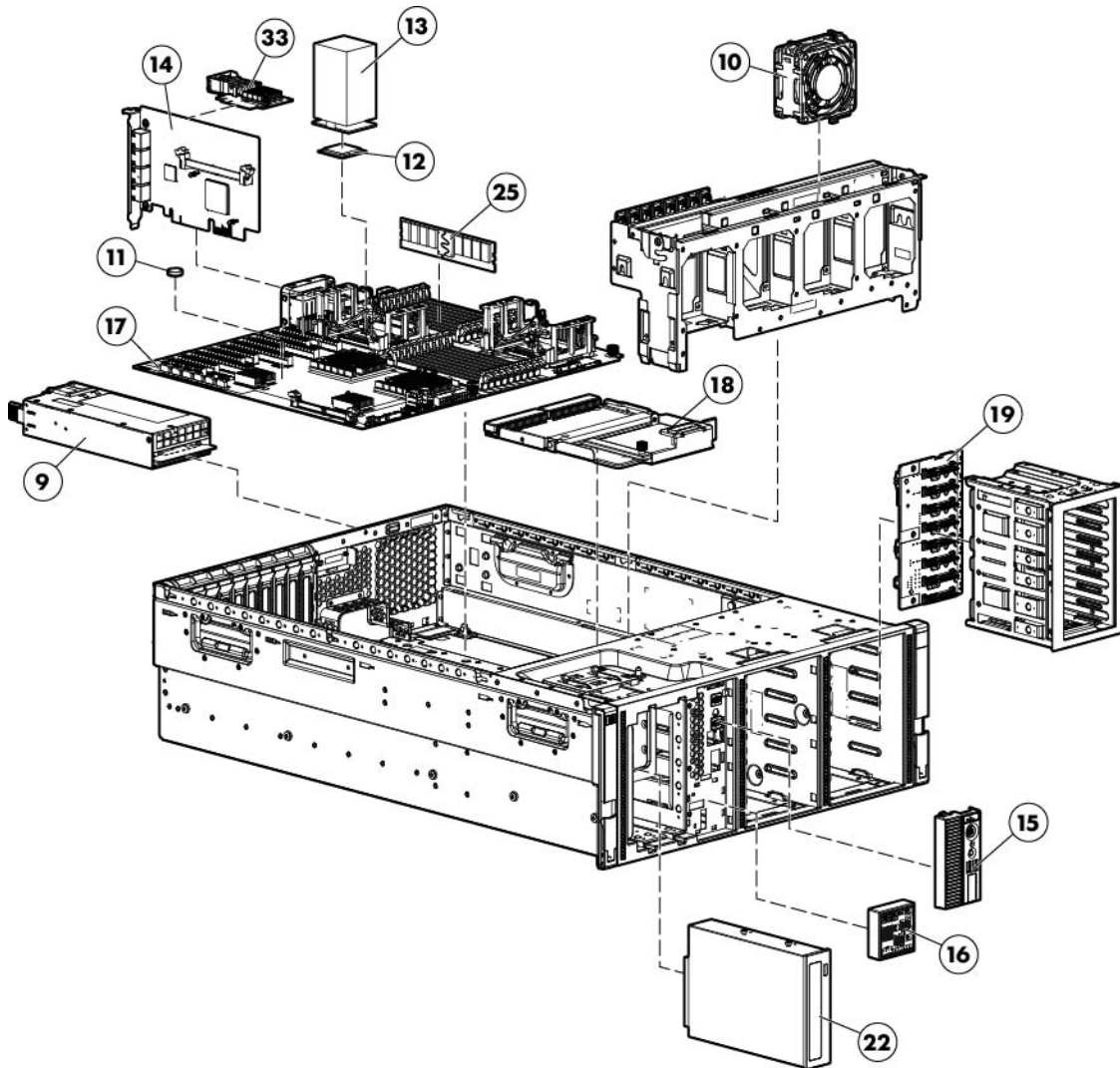

Item	Description	Spare part number	Customer self repair (on page 6)
	System components		
9	Power supply	—	—
	a) Hot-plug power supply, 460-W	511777-001	Mandatory ¹
	b) Hot-plug power supply, 750-W	511778-001	Mandatory ¹
	c) Hot-plug power supply, 1200-W	498152-001	Mandatory ¹
10	Fan	519559-001	Mandatory ¹
11	Battery	153009-001	Mandatory ¹
12	Processor	—	—
	a) 1.86-GHz Intel® Xeon® processor E5502, 80W**	490075-001	Optional ²
	b) 2.00-GHz Intel® Xeon® processor E5503, 80W* **	594889-001	Optional ²

Item	Description	Spare part number	Customer self repair (on page 6)
	c) 2.00-GHz Intel® Xeon® processor E5504, 80W* **	490074-001	Optional ²
	d) 2.13-GHz Intel® Xeon® processor E5506, 80W* **	506013-001	Optional ²
	e) 2.26-GHz Intel® Xeon® processor E5520, 80W* **	490073-001	Optional ²
	f) 2.40-GHz Intel® Xeon® processor E5530, 80W* **	490072-001	Optional ²
	g) 2.53-GHz Intel® Xeon® processor E5540, 80W* **	490071-001	Optional ²
	h) 2.40-GHz Intel® Xeon® processor E5620, 80W* **	594887-001	Optional ²
	i) 2.53-GHz Intel® Xeon® processor E5630, 80W* **	594886-001	Optional ²
	j) 2.66-GHz Intel® Xeon® processor E5640, 80W* **	594885-001	Optional ²
	k) 2.26-GHz Intel® Xeon® processor L5520, 60W* **	504021-001	Optional ²
	l) 2.13-GHz Intel® Xeon® processor L5630, 140W* **	594891-001	Optional ²
	m) 3.20-GHz Intel® Xeon® processor W5580, 130W* **	513597-001	Optional ²
	n) 2.67-GHz Intel® Xeon® processor X5550, 95W* **	490070-001	Optional ²
	o) 2.80-GHz Intel® Xeon® processor X5560, 95W* **	490069-001	Optional ²
	p) 2.93-GHz Intel® Xeon® processor X5570, 95W* **	506012-001	Optional ²
	q) 2.66-GHz Intel® Xeon® processor X5650, 95W* **	594884-001	Optional ²
	r) 2.80-GHz Intel® Xeon® processor X5660, 95W* **	594883-001	Optional ²
	s) 3.06-GHz Intel® Xeon® processor X5667, 95W* **	614533-001	Optional ²
	t) 2.93-GHz Intel® Xeon® processor X5670, 95W* **	594882-001	Optional ²
	u) 3.46-GHz Intel® Xeon® processor X5677, 130W* **	594881-001	Optional ²
	v) 3.33-GHz Intel® Xeon® processor X5680, 95W* **	594880-001	Optional ²
13	Heatsink	508996-001	Optional ²
14	HP NC375i adapter	491838-001	Mandatory ¹
15	I/O bezel	519562-001	Mandatory ¹
16	Systems Insight Display	511786-001	Mandatory ¹

Item	Description	Spare part number	Customer self repair (on page 6)
	Boards		
17	System board	491835-001	Optional ²
18	Power supply backplane with cables	491836-001	Optional ²
19	8-bay SFF drive cage backplane	511785-001	Optional ²
20	6-bay LFF backplane*	491840-001	Optional ²
21	2-bay LFF drive cage backplane*	511786-001	Optional ²
	Storage devices		
22	DVD-ROM drive	447464-001	Mandatory ¹
23	Slimline optical drive*	481428-001	Mandatory ¹
	Miscellaneous		
24	Rack mounting kit*	381679-001	Mandatory ¹
	Memory		
25	DIMMs	—	—
	a) PC3-8500R (DDR-1067) 4-GB RDIMM	501535-001	Mandatory ¹
	b) PC3-8500R (DDR-1067) 8-GB RDIMM	519201-001	Mandatory ¹
	c) PC3-10600R (DDR-1333) 2-GB RDIMM	501533-001	Mandatory ¹
	d) PC3-10600R (DDR-1333) 4-GB RDIMM	501534-001	Mandatory ¹
	e) PC3-10600R (DDR-1333) 16-GB RDIMM	501538-001	Mandatory ¹
	f) PC3-10600E (DDR-1333) 1-GB UDIMM	501539-001	Mandatory ¹
	g) PC3-10600E (DDR-1333) 2-GB UDIMM	501540-001	Mandatory ¹
	h) PC3-10600E (DDR-1333) 4-GB UDIMM	501541-001	Mandatory ¹
	Cables		
26	Miscellaneous cable kit*	519565-001	Mandatory ¹
	a) SAS drive cable	—	—
	b) 2-bay LFF LED cable	—	—
	c) I/O bezel cable assembly	—	—
	d) Power on button cable	—	—
	e) Systems Insight Display sideband cable	—	—
27	Mini-SAS cable*	498426-001	Mandatory ¹
	Options		
28	SFF hard drive*	—	—

Item	Description	Spare part number	Customer self repair (on page 6)
	a) 146-GB, SAS, 10,000-rpm	432320-001	Mandatory ¹
	b) 300-GB, SAS, 10,000-rpm	493083-001	Mandatory ¹
	c) 450-GB, SAS, 10,000-rpm	454274-001	Mandatory ¹
	d) 60-GB, SATA, 5,400-rpm	405419-001	Mandatory ¹
	e) 120-GB, SATA, 5,400-rpm	431908-001	Mandatory ¹
	f) 160-GB, SATA, 5,400-rpm	431909-001	Mandatory ¹
	g) 250-GB, SATA, 5,400-rpm	460427-001	Mandatory ¹
29	LFF hard drive*	—	—
	a) 146-GB, SAS, 15,000-rpm	376595-001	Mandatory ¹
	b) 160-GB, SATA, 7,200-rpm	399968-001	Mandatory ¹
	c) 250-GB, SATA, 7,200-rpm	399969-001	Mandatory ¹
	d) 300-GB, SAS, 15,000-rpm, dual-port	516248-001	Mandatory ¹
	e) 400-GB, SAS, 15,000-rpm	456896-001	Mandatory ¹
	f) 450-GB, SAS, 15,000-rpm, dual-port	454274-001	Mandatory ¹
	g) 500-GB, SATA, 7,200-rpm	404654-001	Mandatory ¹
	h) 750-GB, SAS, 15,000-rpm	461288-001	Mandatory ¹
	i) 1-TB, SAS, 15,000-rpm	461289-001	Mandatory ¹
	j) 2-TB, SAS, 15,000-rpm	508010-001	Mandatory ¹
	k) 750-GB, 7,200-rpm, hot-plug, 3G, NCQ	549320-001	Mandatory ¹
	l) 1-TB, 7,200-rpm, hot-plug, 3G, NCQ	545273-001	Mandatory ¹
	m) 2-TB, 7,200-rpm, hot-plug, 3G, NCQ	508040-001	Mandatory ¹
30	Keyboard*	355630-001	Mandatory ¹
31	Mouse*	344704-001	Mandatory ¹
32	AC power cord*	142258-001	Mandatory ¹
33	HP NC524SFP Dual Port 10GbE Module	490712-001	Optional ²
34	Smart Array P410i controller cache module (512 MB)*	462975-001	Optional ²
35	Smart Array P410i controller battery pack*	488138-001	Optional ²
36	Smart Array P410i controller battery cable assembly, 29.21 cm (11.50 in)*	409124-001	Optional ²
37	Smart Array P410i controller battery cable assembly, 60.96 cm (24.00 in)*	462976-001	Optional ²
38	TPM*	505836-001	No ³
39	Battery cable, 60.96 cm (24.00 in)*	488138-001	Mandatory ¹
40	FBWC capacitor pack*	587324-001	Mandatory ¹

Item	Description	Spare part number	Customer self repair (on page 6)
41	FBWC cache module, 512-MB*	578882-001	Mandatory ¹
42	FBWC cache module, 1-GB*	505908-001	Mandatory ¹

* Not shown

**Do not mix single-, dual-, or quad-core processors, or processors with different cache sizes, speeds, or power consumption.

¹Mandatory—Parts for which customer self repair is mandatory. If you request HP to replace these parts, you will be charged for the travel and labor costs of this service.

²Optional—Parts for which customer self repair is optional. These parts are also designed for customer self repair. If, however, you require that HP replace them for you, there may or may not be additional charges, depending on the type of warranty service designated for your product.

³No—Some HP parts are not designed for customer self repair. In order to satisfy the customer warranty, HP requires that an authorized service provider replace the part. These parts are identified as "No" in the Illustrated Parts Catalog.

¹Mandatory: Obligatoire—Pièces pour lesquelles la réparation par le client est obligatoire. Si vous demandez à HP de remplacer ces pièces, les coûts de déplacement et main d'œuvre du service vous seront facturés.

²Optional: Facultatif—Pièces pour lesquelles la réparation par le client est facultative. Ces pièces sont également conçues pour permettre au client d'effectuer lui-même la réparation. Toutefois, si vous demandez à HP de remplacer ces pièces, l'intervention peut ou non vous être facturée, selon le type de garantie applicable à votre produit.

³No: Non—Certains pièces HP ne sont pas conçues pour permettre au client d'effectuer lui-même la réparation. Pour que la garantie puisse s'appliquer, HP exige que le remplacement de la pièce soit effectué par un Mainteneur Agréé. Ces pièces sont identifiées par la mention "Non" dans le Catalogue illustré.

¹Mandatory: Obbligatorie—Parti che devono essere necessariamente riparate dal cliente. Se il cliente ne affida la riparazione ad HP, deve sostenere le spese di spedizione e di manodopera per il servizio.

²Optional: Opzionali—Parti la cui riparazione da parte del cliente è facoltativa. Si tratta comunque di componenti progettati per questo scopo. Se tuttavia il cliente ne richiede la sostituzione ad HP, potrebbe dover sostenere spese addizionali a seconda del tipo di garanzia previsto per il prodotto.

³No: Non CSR—Alcuni componenti HP non sono progettati per la riparazione da parte del cliente. Per rispettare la garanzia, HP richiede che queste parti siano sostituite da un centro di assistenza autorizzato. Tali parti sono identificate da un "No" nel Catalogo illustrato dei componenti.

¹Mandatory: Zwingend—Teile, die im Rahmen des Customer Self Repair Programms ersetzt werden müssen. Wenn Sie diese Teile von HP ersetzen lassen, werden Ihnen die Versand- und Arbeitskosten für diesen Service berechnet.

²Optional: Optional—Teile, für die das Customer Self Repair-Verfahren optional ist. Diese Teile sind auch für Customer Self Repair ausgelegt. Wenn Sie jedoch den Austausch dieser Teile von HP vornehmen lassen möchten, können bei diesem Service je nach den für Ihr Produkt vorgesehenen Garantiebedingungen zusätzliche Kosten anfallen.

³No: Kein—Einige Teile sind nicht für Customer Self Repair ausgelegt. Um den Garantieanspruch des Kunden zu erfüllen, muss das Teil von einem HP Servicepartner ersetzt werden. Im illustrierten Teilekatalog sind diese Teile mit „No“ bzw. „Nein“ gekennzeichnet.

¹Mandatory: Obligatorio—componentes para los que la reparación por parte del usuario es obligatoria. Si solicita a HP que realice la sustitución de estos componentes, tendrá que hacerse cargo de los gastos de desplazamiento y de mano de obra de dicho servicio.

²Optional: Opcional— componentes para los que la reparación por parte del usuario es opcional. Estos componentes también están diseñados para que puedan ser reparados por el usuario. Sin embargo, si precisa que HP realice su sustitución, puede o no conllevar costes adicionales, dependiendo del tipo de servicio de garantía correspondiente al producto.

³No: No—Algunos componentes no están diseñados para que puedan ser reparados por el usuario. Para que el usuario haga valer su garantía, HP pone como condición que un proveedor de servicios autorizado realice la

sustitución de estos componentes. Dichos componentes se identifican con la palabra "No" en el catálogo ilustrado de componentes.

¹Mandatory: Verplicht—Onderdelen waarvoor Customer Self Repair verplicht is. Als u HP verzoekt deze onderdelen te vervangen, komen de reiskosten en het arbeidsloon voor uw rekening.

²Optional: Optioneel—Onderdelen waarvoor reparatie door de klant optioneel is. Ook deze onderdelen zijn ontworpen voor reparatie door de klant. Als u echter HP verzoekt deze onderdelen voor u te vervangen, kunnen daarvoor extra kosten in rekening worden gebracht, afhankelijk van het type garantieservice voor het product.

³No: Nee—Sommige HP onderdelen zijn niet ontwikkeld voor reparatie door de klant. In verband met de garantievoorwaarden moet het onderdeel door een geautoriseerde Service Partner worden vervangen. Deze onderdelen worden in de geïllustreerde onderdelencatalogus aangemerkt met "Nee".

¹Mandatory: Obrigatória—Peças cujo reparo feito pelo cliente é obrigatório. Se desejar que a HP substitua essas peças, serão cobradas as despesas de transporte e mão-de-obra do serviço.

²Optional: Opcional—Peças cujo reparo feito pelo cliente é opcional. Essas peças também são projetadas para o reparo feito pelo cliente. No entanto, se desejar que a HP as substitua, pode haver ou não a cobrança de taxa adicional, dependendo do tipo de serviço de garantia destinado ao produto.

³No: Nenhuma—Algumas peças da HP não são projetadas para o reparo feito pelo cliente. A fim de cumprir a garantia do cliente, a HP exige que um técnico autorizado substitua a peça. Essas peças estão identificadas com a marca "No" (Não), no catálogo de peças ilustrado.

¹Mandatory : 必須 - 顧客自己修理が必須の部品。当該部品について、もしもお客様がHPに交換作業を依頼される場合には、その修理サービスに関する交通費および人件費がお客様に請求されます。

²Optional : 任意 - 顧客自己修理が任意である部品。この部品も顧客自己修理用です。当該部品について、もしもお客様がHPに交換作業を依頼される場合には、お買い上げの製品に適用される保証サービス内容の範囲内においては、費用を負担していただくことなく保証サービスを受けることができます。

³No : 除外 - HP製品の一部の部品は、顧客自己修理用ではありません。製品の保証を継続するためには、HPまたはHP正規保守代理店による交換作業が必須となります。部品カタログには、当該部品が顧客自己修理除外品である旨が記載されています。

¹Mandatory: 强制性的 — 要求客户必须自行维修的部件。如果您请求 HP 更换这些部件，则必须为该服务支付差旅费和人工费用。

²Optional: 可选的 — 客户可以选择是否自行维修的部件。这些部件也是为客户自行维修设计的。不过，如果您要求 HP 为您更换这些部件，则根据您的产品指定的保修服务类型，HP 可能收取或不再收取任何附加费用。

³No: 否 — 某些 HP 部件的设计并未考虑客户自行维修。为了满足客户保修的需要，HP 要求授权服务提供商更换相关部件。这些部件在部件图解目录中标记为“否”。

¹Mandatory: 强制的 — 客户自行维修所使用的零件是强制性的。如果您要求 HP 更换这些零件，HP 将会向您收取此服务所需的外出费用与劳动成本。

²Optional: 選購的 — 客户自行维修所使用的零件是選購的。這些零件也設計用於客戶自行維修之用。不過，如果您要求 HP 為您更換，則可能需要也可能不需要負擔額外的費用，端視針對此產品指定的保固服務類型而定。

³No: 否 — 某些 HP 零件沒有消費者可自行維修的設計。為符合客戶保固，HP 需要授權的服務供應商更換零件。這些零件在圖示的零件目錄中，被標示為「否」。

¹ Mandatory: 필수 — 고객 셀프 수리가 의무 사항인 필수 부품. 사용자가 HP에 이 부품의 교체를 요청할 경우 이 서비스에 대한 출장비 및 작업비가 청구됩니다.

² Optional: 옵션 — 고객 셀프 수리가 선택 사항인 부품. 이 부품들도 고객 셀프 수리가 가능하도록 설계되었습니다. 하지만 사용자가 HP에 이 부품의 교체를 요청할 경우 사용자가 구입한 제품에 해당하는 보증 서비스 유형에 따라 추가 비용 없이 교체가 가능할 수 있습니다.

³ No: No — 고객 셀프 수리가 불가능하도록 설계된 HP 부품. 이 부품들은 고객 셀프 수리가 불가능하도록 설계되었습니다. HP는 고객 보증을 만족시키기 위해 공인 서비스 제공업체를 통해 부품을 교체하도록 하고 있습니다.

Removal and replacement procedures

Required tools

You need the following items for some procedures:

- T-10/T-15 Torx screwdriver (included with the server)
- Diagnostics Utility (included on the SmartStart CD-ROM)

Safety considerations

Before performing service procedures, review all the safety information.

Preventing electrostatic discharge

To prevent damaging the system, be aware of the precautions you need to follow when setting up the system or handling parts. A discharge of static electricity from a finger or other conductor may damage system boards or other static-sensitive devices. This type of damage may reduce the life expectancy of the device.

To prevent electrostatic damage:

- Avoid hand contact by transporting and storing products in static-safe containers.
- Keep electrostatic-sensitive parts in their containers until they arrive at static-free workstations.
- Place parts on a grounded surface before removing them from their containers.
- Avoid touching pins, leads, or circuitry.
- Always be properly grounded when touching a static-sensitive component or assembly.

Symbols on equipment

The following symbols may be placed on equipment to indicate the presence of potentially hazardous conditions.



This symbol indicates the presence of hazardous energy circuits or electric shock hazards. Refer all servicing to qualified personnel.

WARNING: To reduce the risk of injury from electric shock hazards, do not open this enclosure. Refer all maintenance, upgrades, and servicing to qualified personnel.



This symbol indicates the presence of electric shock hazards. The area contains no user or field serviceable parts. Do not open for any reason.

WARNING: To reduce the risk of injury from electric shock hazards, do not open this enclosure.



This symbol on an RJ-45 receptacle indicates a network interface connection.

WARNING: To reduce the risk of electric shock, fire, or damage to the equipment, do not plug telephone or telecommunications connectors into this receptacle.



This symbol indicates the presence of a hot surface or hot component. If this surface is contacted, the potential for injury exists.

WARNING: To reduce the risk of injury from a hot component, allow the surface to cool before touching.



25-47 kg
55-103 lb

This symbol indicates that the component exceeds the recommended weight for one individual to handle safely.

WARNING: To reduce the risk of personal injury or damage to the equipment, observe local occupational health and safety requirements and guidelines for manual material handling.



These symbols, on power supplies or systems, indicate that the equipment is supplied by multiple sources of power.

WARNING: To reduce the risk of injury from electric shock, remove all power cords to completely disconnect power from the system.

Rack warnings



WARNING: To reduce the risk of personal injury or damage to the equipment, be sure that:

- The leveling jacks are extended to the floor.
- The full weight of the rack rests on the leveling jacks.
- The stabilizing feet are attached to the rack if it is a single-rack installation.
- The racks are coupled together in multiple-rack installations.
- Only one component is extended at a time. A rack may become unstable if more than one component is extended for any reason.



WARNING: To reduce the risk of personal injury or equipment damage when unloading a rack:

- At least two people are needed to safely unload the rack from the pallet. An empty 42U rack can weigh as much as 115 kg (253 lb), can stand more than 2.1 m (7 ft) tall, and may become unstable when being moved on its casters.
- Never stand in front of the rack when it is rolling down the ramp from the pallet. Always handle the rack from both sides.



WARNING: To reduce the risk of personal injury or damage to the equipment, adequately stabilize the rack before extending a component outside the rack. Extend only one component at a time. A rack may become unstable if more than one component is extended.



WARNING: When installing a server in a telco rack, be sure that the rack frame is adequately secured at the top and bottom to the building structure.

Preparation procedures

To access some components and perform certain service procedures, you must perform one or more of the following procedures:

- Extend the server from the rack (on page 30).
If you are performing service procedures in an HP, Compaq branded, telco, or third-party rack cabinet, you can use the locking feature of the rack rails to support the server and gain access to internal components.
For more information about telco rack solutions, refer to the RackSolutions.com website (<http://www.racksolutions.com/hp>).
- Power down the server (on page 29).
If you must remove a server from a rack or a non-hot-plug component from a server, power down the server.
- Remove the server from the rack (on page 29).
If the rack environment, cabling configuration, or the server location in the rack creates awkward conditions, remove the server from the rack.

Power down the server



WARNING: To reduce the risk of personal injury, electric shock, or damage to the equipment, remove the power cord to remove power from the server. The front panel Power On/Standby button does not completely shut off system power. Portions of the power supply and some internal circuitry remain active until AC power is removed.



IMPORTANT: If installing a hot-plug device, it is not necessary to power down the server.

1. Shut down the OS as directed by the OS documentation.
2. Press the Power On/Standby button to place the server in standby mode. When the server enters standby power mode, the system power LED changes to amber.
3. Disconnect the power cords.

The system is now without power.

Remove the server from the rack

To remove the server from an HP, telco, or third-party rack:

1. Power down the server (on page 29).
2. Disconnect the cabling.
3. Extend the server from the rack. Reverse the server installation steps in the documentation that ships with the rack-mounting option.



CAUTION: Do not use the server release lever to lift or carry the server. Always support the weight of the server by handling the chassis directly. Improper use can damage the release lever and the server.

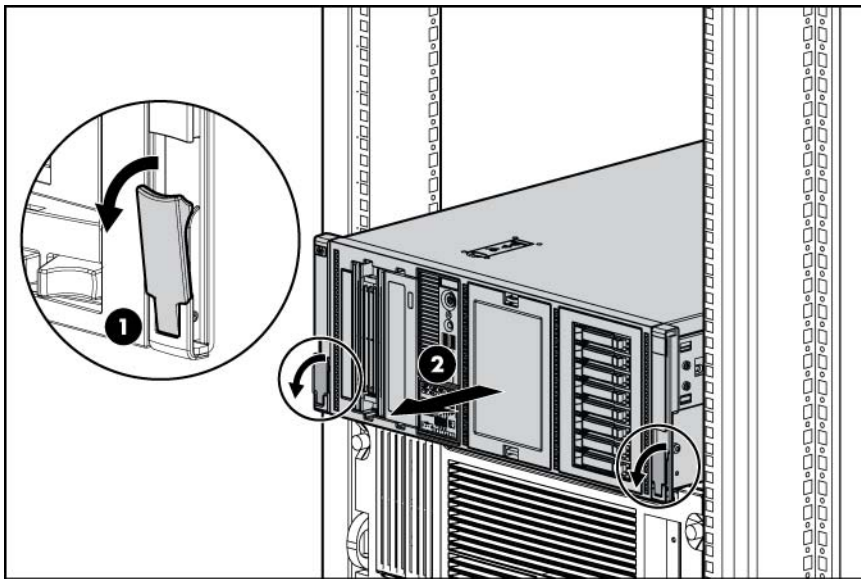

4. Press the server rail-release latches and remove the server from the rack.
5. Place the server on a sturdy, level surface.

Extend the server from the rack



IMPORTANT: If the server is installed in a telco rack, remove the server from the rack to access internal components.

1. Extend the server on the rack rails until the server rail-release latches engage.



WARNING: To reduce the risk of personal injury or equipment damage, be sure that the rack is adequately stabilized before extending a component from the rack.



WARNING: To reduce the risk of personal injury, be careful when pressing the server rail-release latches and sliding the server into the rack. The sliding rails could pinch your fingers.

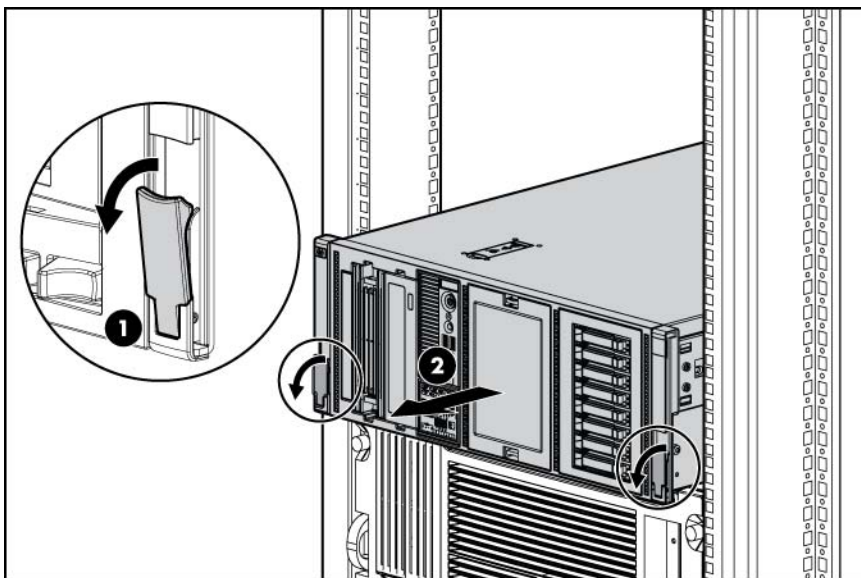

2. After performing the installation or maintenance procedure, slide the server into the rack by pressing the server rail-release latches.

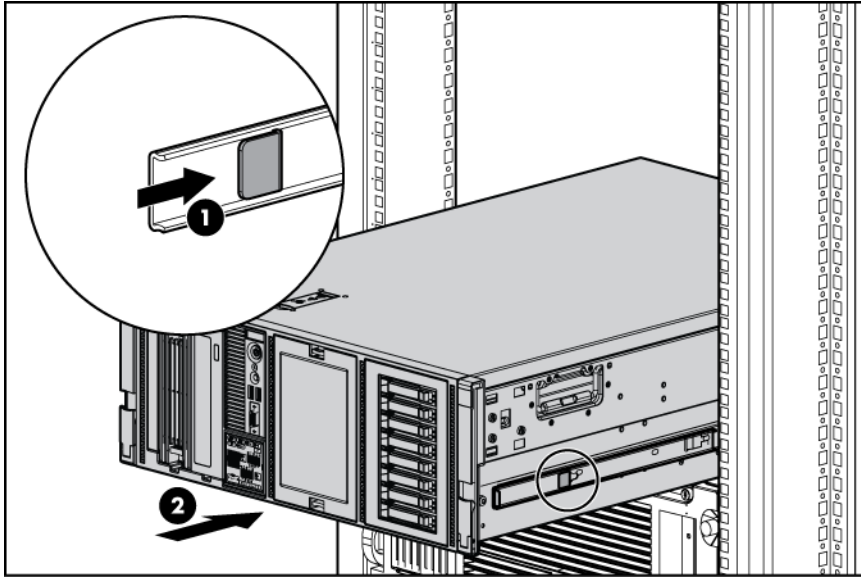

Access the product rear panel

Cable management arm with left-hand swing

To access the server rear panel, open the cable management arm.

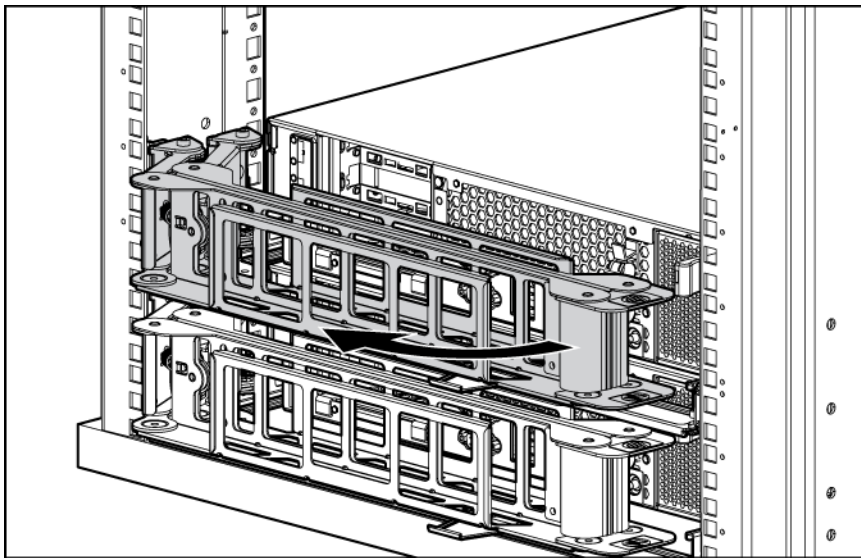

Cable management arm with right-hand swing

NOTE: To access some components, you may need to remove the cable management arm.

To access the product rear panel components, open the cable management arm:

1. Power down the server (on page 29).

2. Swing open the cable management arm.
3. Remove the cables from the cable trough.
4. Remove the cable management arm.

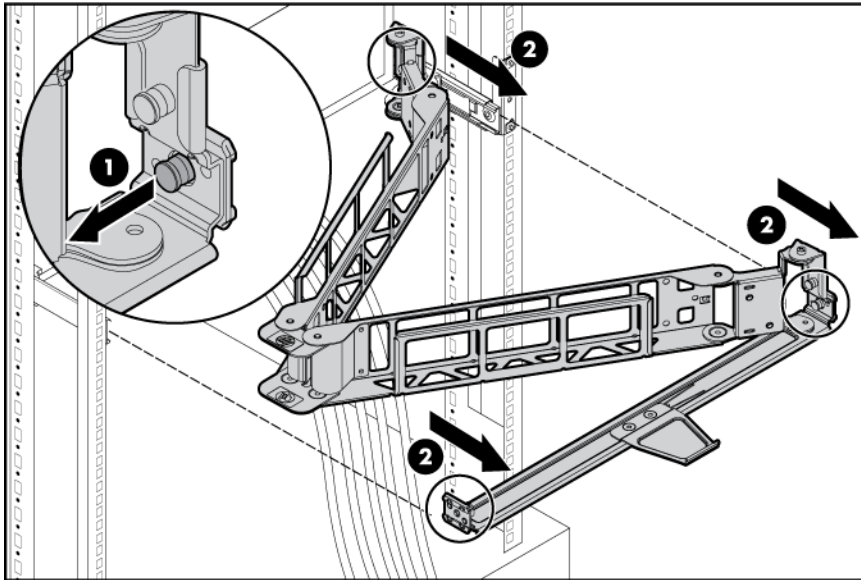

Tower bezel

This server has a removable bezel that must be unlocked and opened before accessing the hard drives or removing the access panel. The bezel should be kept closed during normal server operations.

To remove the component:

1. Use the key provided with the server to unlock the bezel with a counterclockwise turn.

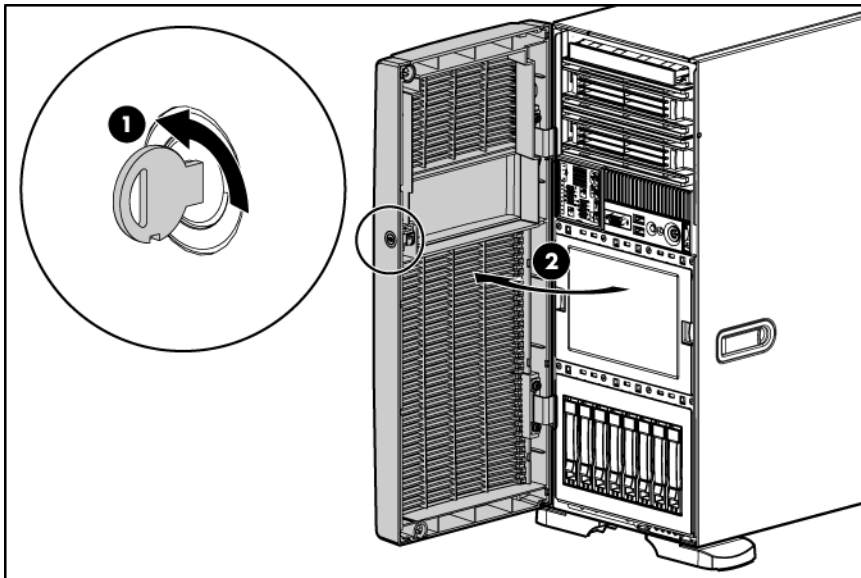

2. Remove the tower bezel.

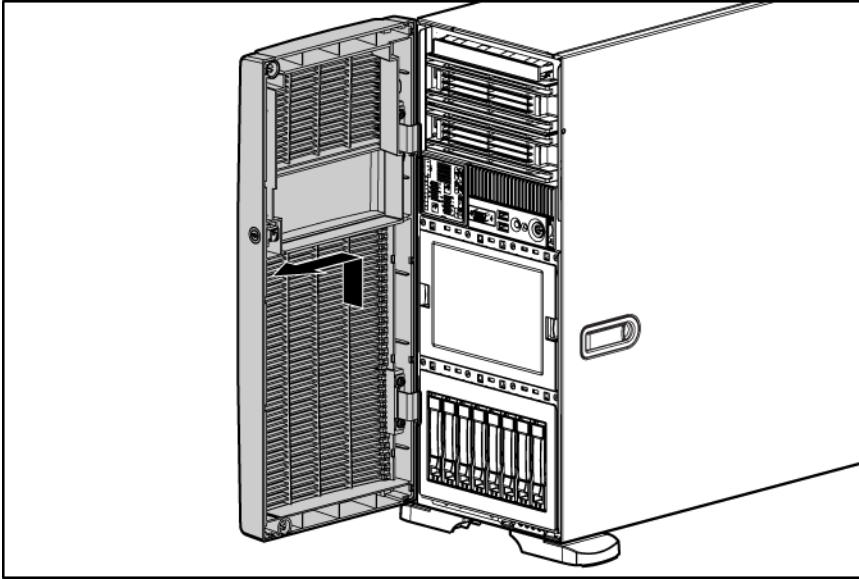

To replace the component, reverse the removal procedure.

Access panel

-
- ⚠ **WARNING:** To reduce the risk of personal injury from hot surfaces, allow the drives and the internal system components to cool before touching them.
-
- ⚠ **CAUTION:** Do not operate the server for long periods with the access panel open or removed. Operating the server in this manner results in improper airflow and improper cooling that can lead to thermal damage.
-

To remove the component:

1. Do one of the following:
 - Open or remove the tower bezel, as needed ("[Tower bezel](#)" on page [32](#)).
 - Extend the server from the rack (on page [30](#)).
2. Open the locking latch, slide the access panel to the rear of the chassis, and remove the access panel.

If the locking latch is locked, use a T-15 Torx screwdriver to unlock the latch.

To replace the component, reverse the removal procedure.

Fan 5

To remove the component:

1. Power down the server (on page [29](#)).
2. Do one of the following:
 - Open or remove the tower bezel, as needed ("[Tower bezel](#)" on page [32](#)).
 - Extend the server from the rack (on page [30](#)).

3. Remove the access panel ("Access panel" on page 33).
4. Remove the fan from the air baffle.

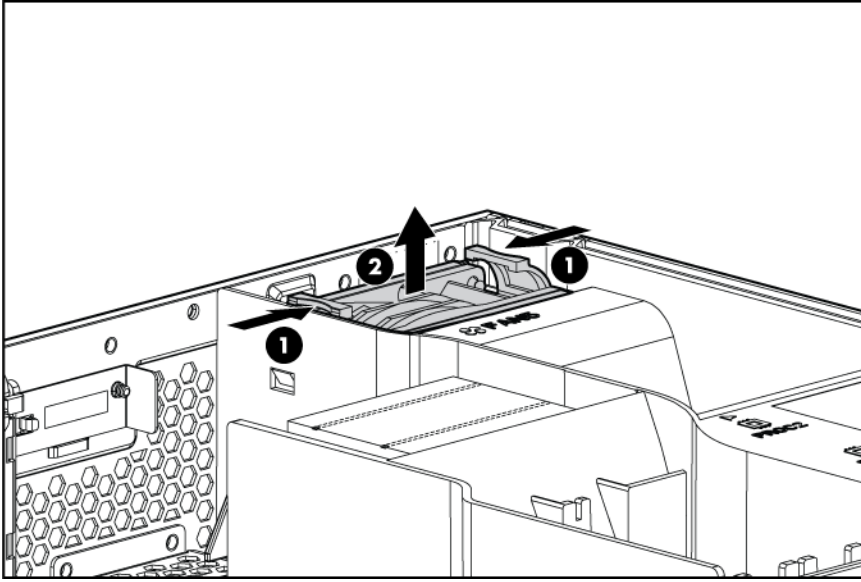

To replace the component, reverse the removal procedure.

Cache module

-
- △ **CAUTION:** Do not use this controller with cache modules designed for other controller models, because the controller can malfunction and you can lose data. Also, do not transfer this cache module to a different controller module, because you can lose data.
-

To remove the component:

1. Power down the server (on page 29).

-
- △ **CAUTION:** In systems that use external data storage, be sure that the server is the first unit to be powered down and the last to be powered back up. Taking this precaution ensures that the system does not erroneously mark the drives as failed when the server is powered up.
-

2. Do one of the following:
 - Unlock and remove the bezel ("Tower bezel" on page 32).
 - Extend the server from the rack (on page 30).
3. Remove the access panel ("Access panel" on page 33).

4. Remove the cache module.

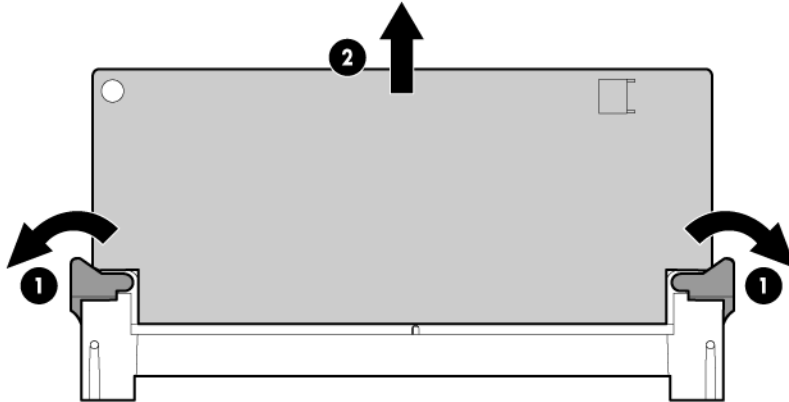

To replace the component, reverse the removal procedure.

BBWC battery pack or FBWC capacitor pack

- △ **CAUTION:** To prevent a server malfunction or damage to the equipment, do not add or remove the battery pack while an array capacity expansion, RAID level migration, or stripe size migration is in progress.
- △ **CAUTION:** After the server is powered down, wait 15 seconds and then check the amber LED before unplugging the cable from the cache module. If the amber LED blinks after 15 seconds, do not remove the cable from the cache module. The cache module is backing up data, and data is lost if the cable is detached.

To remove the component:

1. Power down the server (on page 29).
2. Do one of the following:
 - Open or remove the tower bezel, as needed ("Tower bezel" on page 32).
 - Extend the server from the rack (on page 30).
3. Remove the access panel ("Access panel" on page 33).
4. Disconnect the cable from the cache module only if the battery pack is not being used to recover data from the server or transfer data to another server.

5. Remove the battery pack.

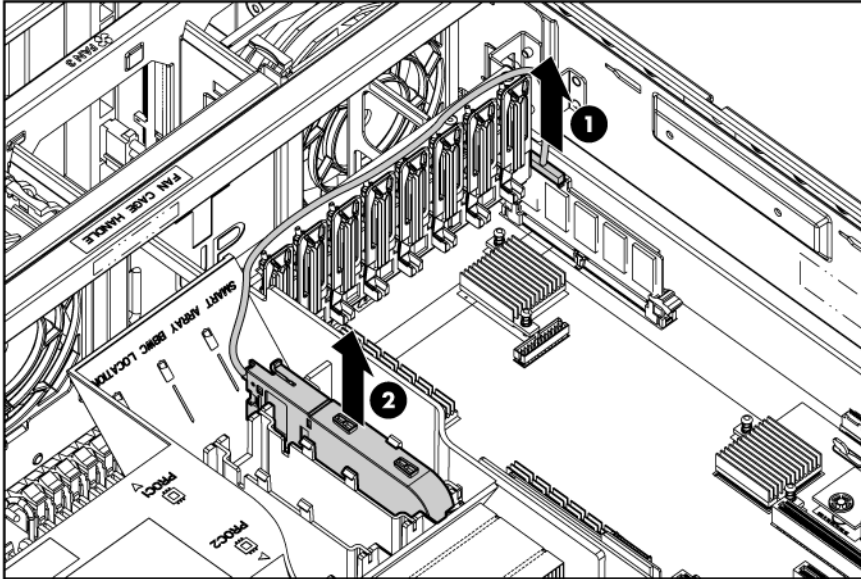

To replace the component, reverse the removal procedure.

Air baffle

To remove the component:

1. Power down the server (on page 29).
2. Do one of the following:
 - o Open or remove the tower bezel, as needed ("Tower bezel" on page 32).
 - o Extend the server from the rack (on page 30).
3. Remove the access panel ("Access panel" on page 33).
4. Remove fan 5 ("Fan 5" on page 33).
5. If installed, remove the BBWC battery pack or the FBWC capacitor pack ("BBWC battery pack or FBWC capacitor pack" on page 35).

6. Remove the air baffle.

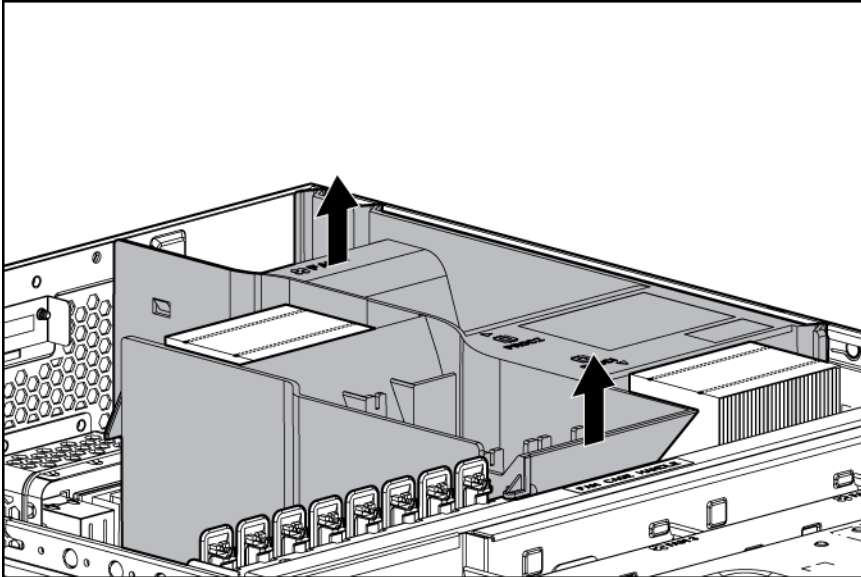

To replace the component, reverse the removal procedure.

Remove the fan cage

1. Power down the server (on page 29).
2. Do one of the following:
 - o Open or remove the tower bezel, as needed ("[Tower bezel](#)" on page 32).
 - o Extend the server from the rack (on page 30).
3. Remove the access panel ("[Access panel](#)" on page 33).
4. Remove fan 5 ("[Fan 5](#)" on page 33).
5. If installed, remove the BBWC battery pack or the FBWC capacitor pack ("[BBWC battery pack or FBWC capacitor pack](#)" on page 35).
6. Remove the air baffle ("[Air baffle](#)" on page 36).

7. Remove the fan cage.

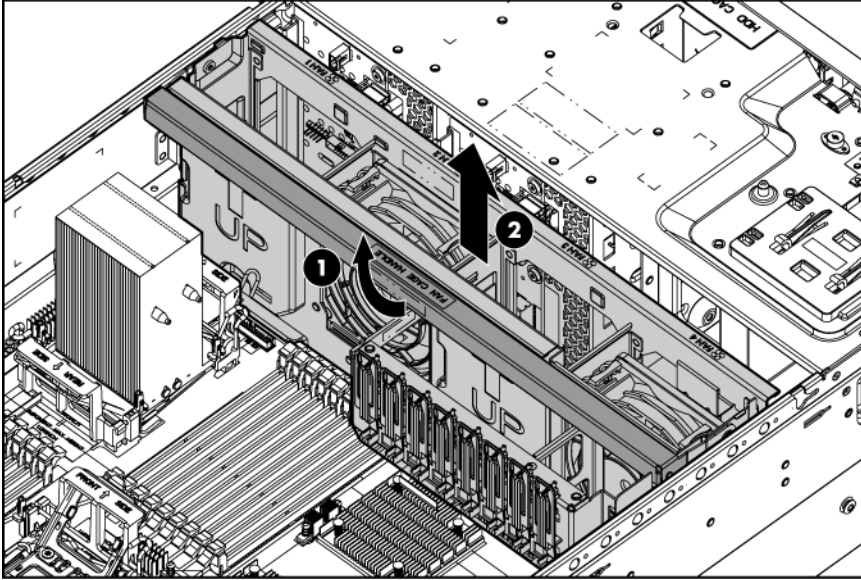

Fan blank

CAUTION: To prevent improper cooling and thermal damage, do not operate the server unless all bays are populated with either a component or a blank.

To remove the component:

1. Power down the server (on page 29).
2. Do one of the following:
 - o Open or remove the tower bezel, as needed ("Tower bezel" on page 32).
 - o Extend the server from the rack (on page 30).
3. Remove the access panel ("Access panel" on page 33).
4. Remove fan 5 ("Fan 5" on page 33).
5. If installed, remove the BBWC battery pack or the FBWC capacitor pack ("BBWC battery pack or FBWC capacitor pack" on page 35).
6. Remove the air baffle ("Air baffle" on page 36).

7. Remove the fan blank.

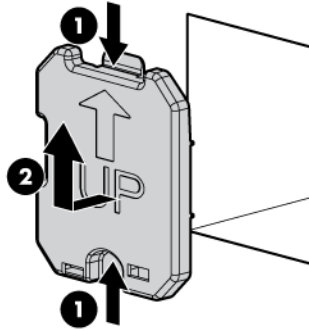

To replace the component, reverse the removal procedure.

Fans 1-4



CAUTION: To prevent improper cooling and thermal damage, do not operate the server unless all bays are populated with either a component or a blank.

To remove the component:

1. Power down the server (on page 29).
2. Do one of the following:
 - o Open or remove the tower bezel, as needed ("[Tower bezel](#)" on page 32).
 - o Extend the server from the rack (on page 30).
3. Remove the access panel ("[Access panel](#)" on page 33).
4. Locate the fan to be removed ("[Fans](#)" on page 100).

5. Remove the fan.

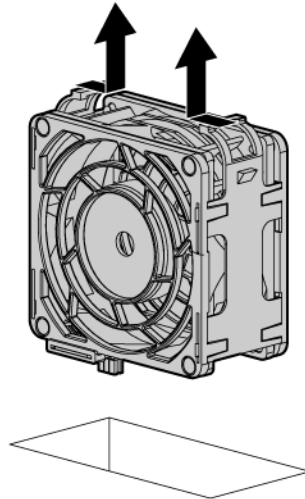

To replace the component, reverse the removal procedure.

Tower side panels

To remove the component:

1. Power down the server (on page 29).
2. Do one of the following:
 - o Open or remove the tower bezel, as needed ("[Tower bezel](#)" on page 32).
 - o Extend the server from the rack (on page 30).
3. With a T-15 Torx screwdriver, remove the following seven screws:
 - o Inside (4)

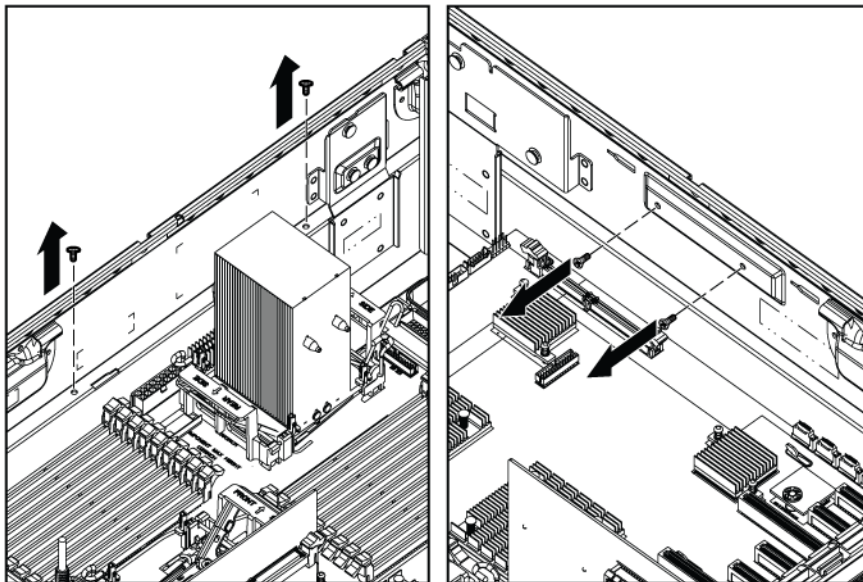

- Rear (1)

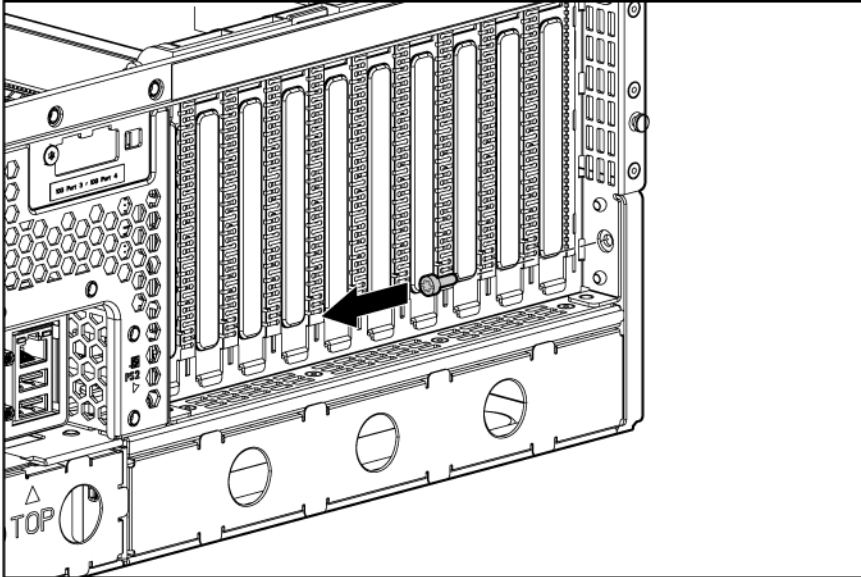

- Front (2)

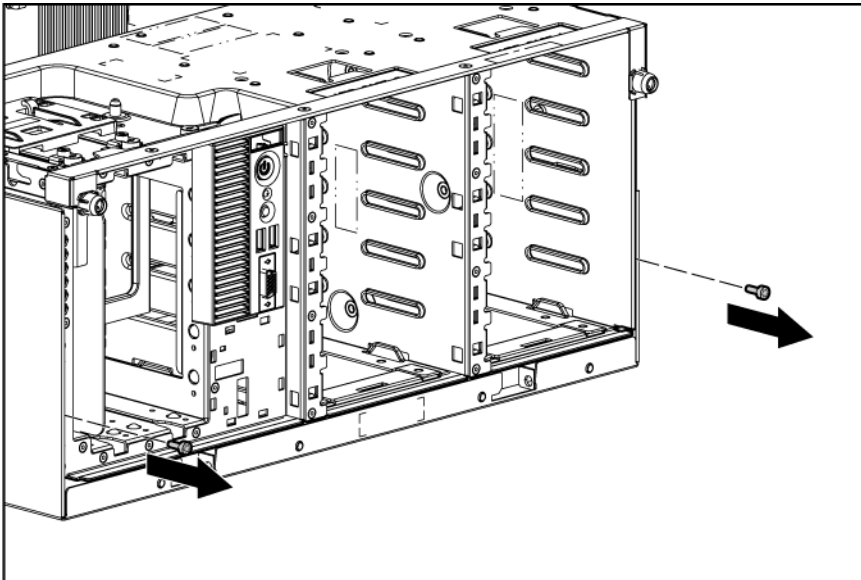

4. Remove the chassis from the tower side panels:

- a. Disengage the chassis from the tower side panels by pushing the bottom side panel back and by pulling the chassis forward.

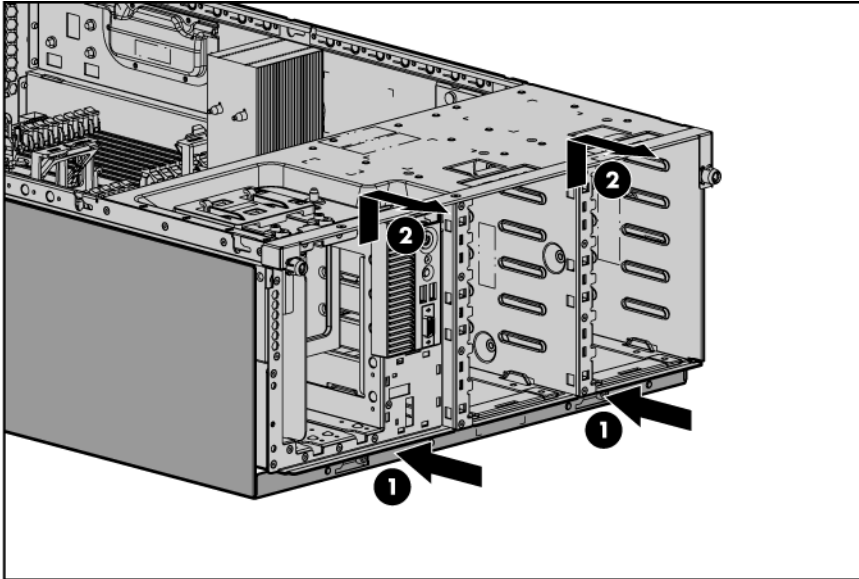

- b. Lift the chassis up and out of the tower side panels.

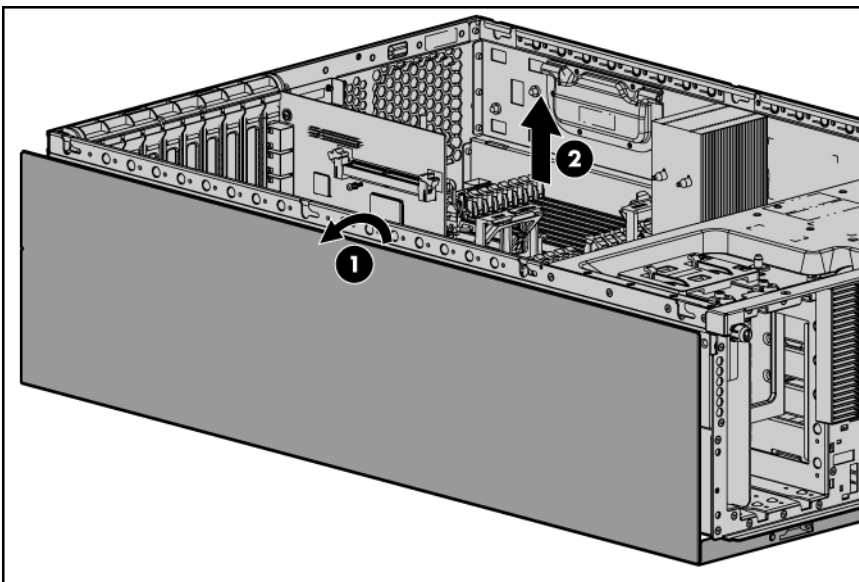

To replace the component, reverse the removal procedure.

Feet

NOTE: This procedure applies to tower servers only.

To remove the component:

1. Power down the server (on page 29).
2. Place the server on its side.

3. Remove the feet.

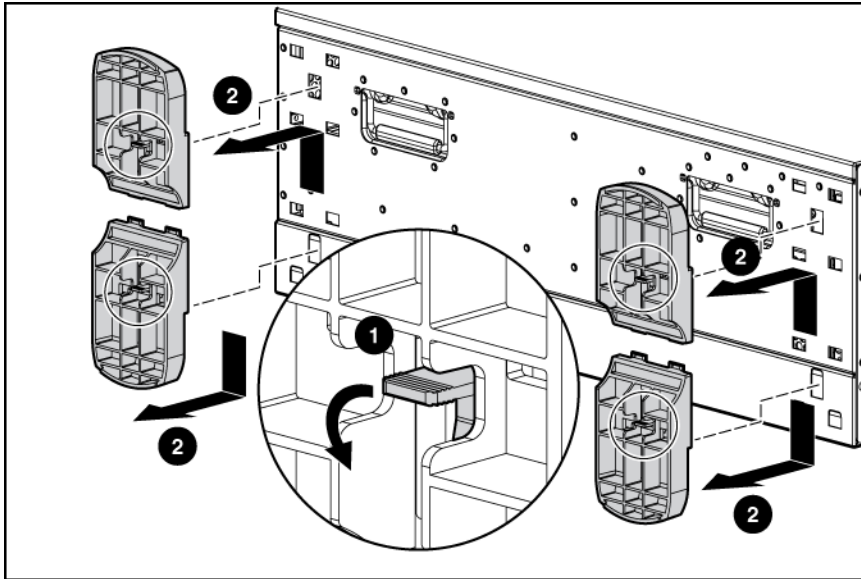

To replace the component, slide it back into the locking slot. Be sure that the foot clicks securely into the chassis. Repeat with the remaining feet, as necessary.

SAS hard drive blank

- △ **CAUTION:** For proper cooling do not operate the server without the access panel, baffles, expansion slot covers, or blanks installed. If the server supports hot-plug components, minimize the amount of time the access panel is open.

Remove the component as indicated.

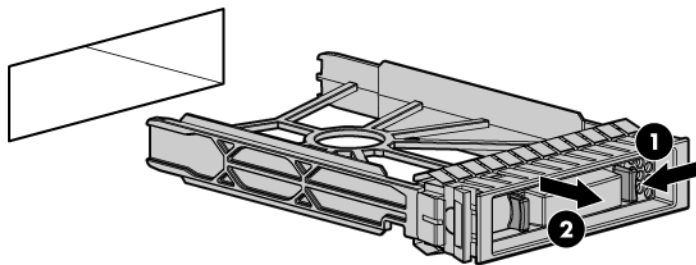

To replace the blank, slide the blank into the bay until it locks into place.

SAS/SATA hard drive

- △ **CAUTION:** To prevent improper cooling and thermal damage, do not operate the server unless all bays are populated with either a component or a blank.

To remove the component:

1. Determine the status of the hard drive from the hot-plug SAS hard drive LED combinations ("[SAS and SATA hard drive LED combinations](#)" on page 99).

2. Back up all server data on the hard drive.
3. Remove the hard drive.

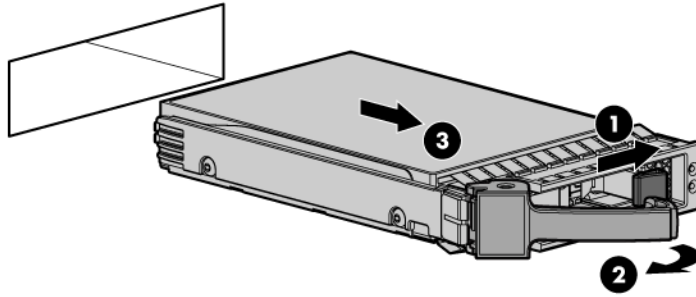

To replace the component, reverse the removal procedure.

Media bay blank

CAUTION: To prevent improper cooling and thermal damage, do not operate the server unless all bays are populated with either a component or a blank.

To remove the component:

1. Power down the server (on page 29).
2. Remove the tower bezel ("Tower bezel" on page 32).
3. Remove the media bay blank.

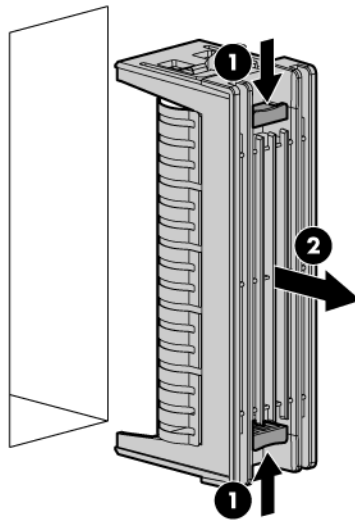

To replace the component, reverse the removal procedure.

DVD-ROM drive

CAUTION: To prevent improper cooling and thermal damage, do not operate the server unless all bays are populated with either a component or a blank.

To remove the component:

1. Power down the server (on page 29).
2. Do one of the following:
 - o Open or remove the tower bezel, as needed ("Tower bezel" on page 32).
 - o Extend the server from the rack (on page 30).
3. Remove the access panel ("Access panel" on page 33).
4. Remove fan 5 ("Fan 5" on page 33).
5. If installed, remove the BBWC battery pack or the FBWC capacitor pack ("BBWC battery pack or FBWC capacitor pack" on page 35).
6. Remove the air baffle ("Air baffle" on page 36).
7. Remove the fan cage (on page 37).
8. Disconnect and remove the DVD-ROM drive data/power cable. For more information, see "DVD-ROM drive cabling (on page 83)."
9. Remove the DVD-ROM drive.

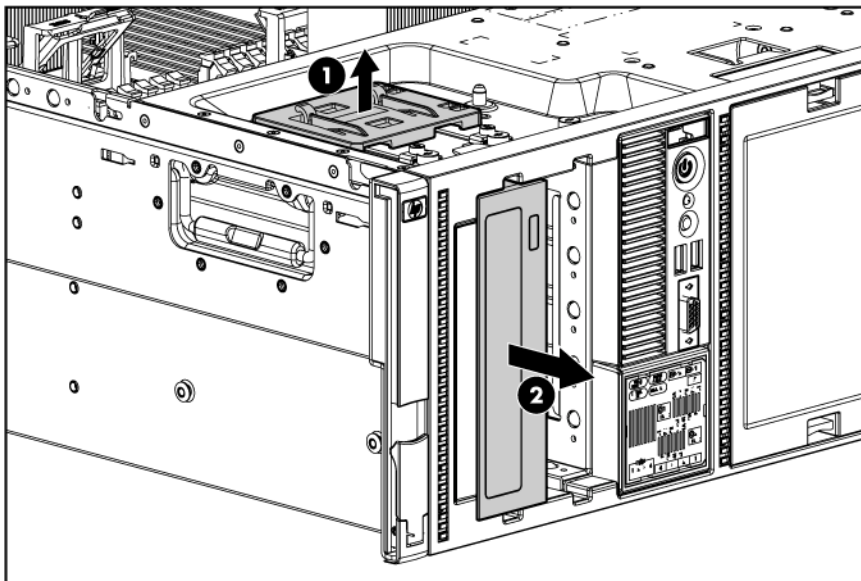

To replace the component, reverse the removal procedure.

Slimline optical drive

To remove the component:

1. Power down the server (on page 29).
2. Do one of the following:
 - o Open or remove the tower bezel, as needed ("Tower bezel" on page 32).
 - o Extend the server from the rack (on page 30).
3. Remove the access panel ("Access panel" on page 33).
4. Remove fan 5 ("Fan 5" on page 33).
5. If installed, remove the BBWC battery pack or the FBWC capacitor pack ("BBWC battery pack or FBWC capacitor pack" on page 35).

6. Remove the air baffle ("Air baffle" on page 36).
7. Remove the fan cage (on page 37).
8. Disconnect the data and power cable from the rear of the optical drive.
9. Remove the optical drive.

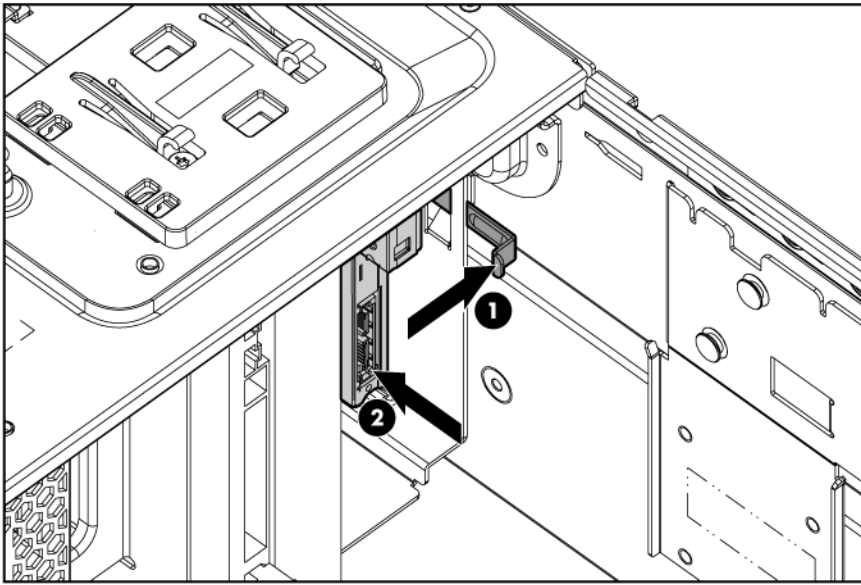

△ **CAUTION:** To prevent improper cooling and thermal damage, do not operate the server unless all bays are populated with either a component or a blank.

To replace the component, reverse the removal procedure.

Hard drive cage blank

△ **CAUTION:** To prevent improper cooling and thermal damage, do not operate the server unless all bays are populated with either a component or a blank.

Remove the component as indicated.

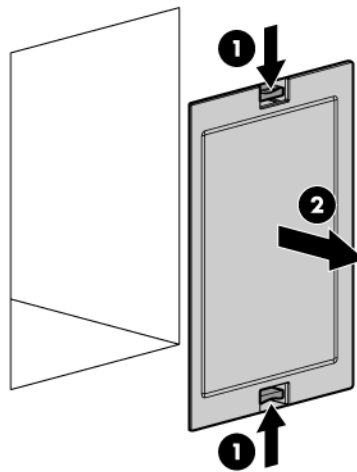

To replace the component, reverse the removal procedure.

Hard drive cages and backplanes

The server supports the following hard drive cages and backplanes:

- Two-bay LFF drive cage (on page [47](#))
- Six-bay LFF backplane (on page [49](#))
- Eight-bay SFF drive cage backplane (bay 1) (on page [50](#))
- Eight-bay SFF drive cage backplane (bay 2) (on page [51](#))
- Eight-bay SFF drive cage backplane (bay 3) (on page [53](#))

For jumper settings, see "Drive cage jumper location and configuration settings (on page [104](#))."

Two-bay LFF drive cage

To remove the component:

1. Power down the server (on page [29](#)).
2. Do one of the following:
 - Open or remove the tower bezel, as needed ("[Tower bezel](#)" on page [32](#)).
 - Extend the server from the rack (on page [30](#)).
3. Remove the access panel ("[Access panel](#)" on page [33](#)).
4. Remove fan 5 ("[Fan 5](#)" on page [33](#)).
5. If installed, remove the BBWC battery pack or the FBWC capacitor pack ("[BBWC battery pack or FBWC capacitor pack](#)" on page [35](#)).
6. Remove the air baffle ("[Air baffle](#)" on page [36](#)).
7. Remove the fan cage (on page [37](#)).
8. Disconnect the data and power cables from the two-bay LFF drive cage.
9. Remove all LFF drives installed in the drive cage ("[SAS/SATA hard drive](#)" on page [43](#)).

10. Remove the locking brackets.

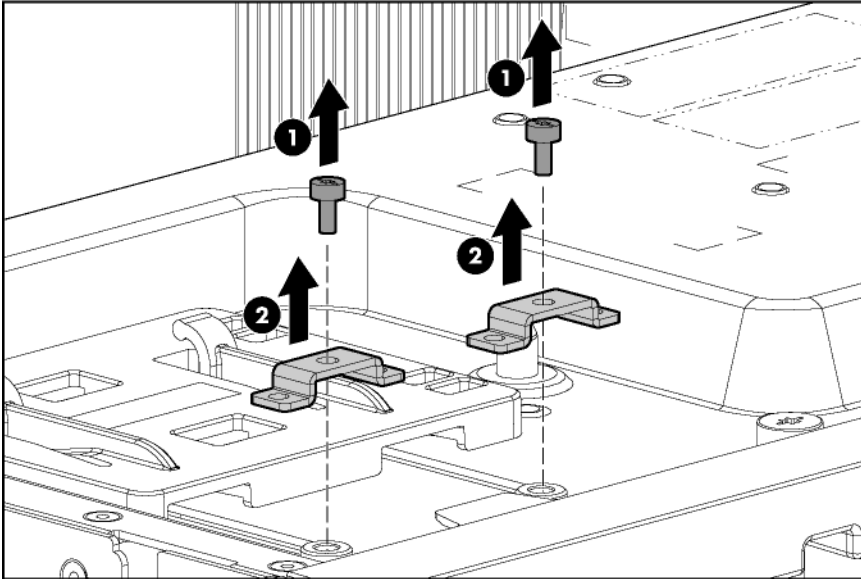

11. Remove the two-bay LFF drive cage.

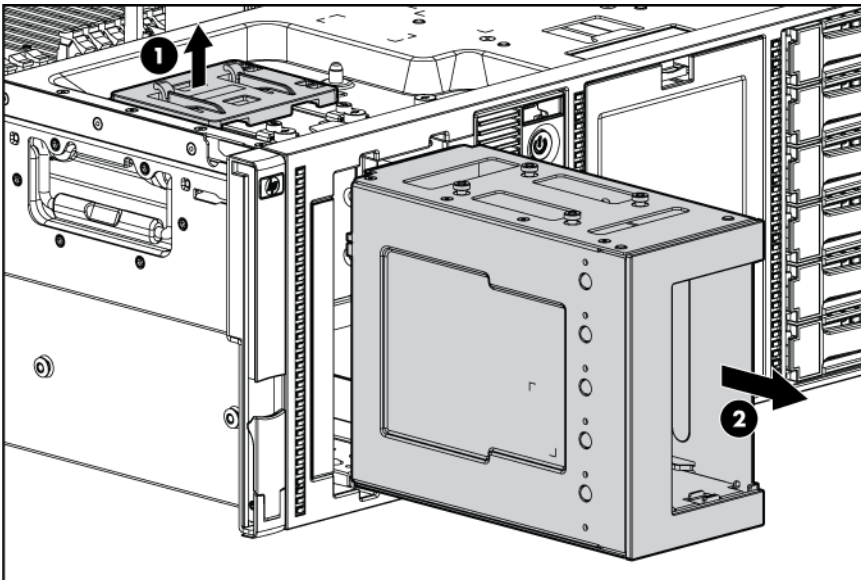

- Using a T-15 Torx screwdriver, remove the backplane from the drive cage.

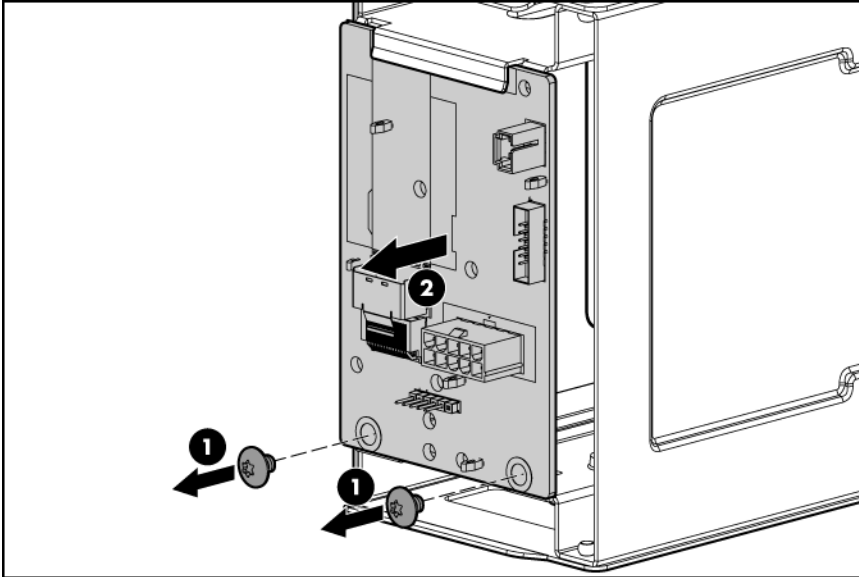

CAUTION: To prevent improper cooling and thermal damage, do not operate the server unless all bays are populated with either a component or a blank.

To replace the component, reverse the removal procedure.

Six-bay LFF backplane

To remove the component:

- Power down the server (on page 29).
- Do one of the following:
 - Open or remove the tower bezel, as needed ("[Tower bezel](#)" on page 32).
 - Extend the server from the rack (on page 30).
- Remove the access panel ("[Access panel](#)" on page 33).
- Remove fan 5 ("[Fan 5](#)" on page 33).
- If installed, remove the BBWC battery pack or the FBWC capacitor pack ("[BBWC battery pack or FBWC capacitor pack](#)" on page 35).
- Remove the air baffle ("[Air baffle](#)" on page 36).
- Remove the fan cage (on page 37).
- Disconnect the power and data cables from the six-bay LFF backplane.
- Remove any LFF drives installed in the drive cage bay ("[SAS/SATA hard drive](#)" on page 43).

- Using a T-15 Torx screwdriver, remove the six-bay LFF backplane.

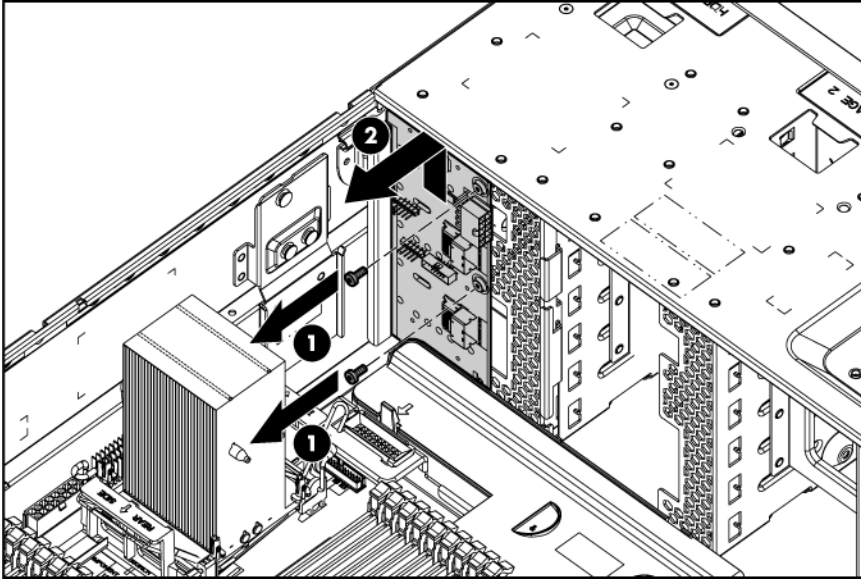

CAUTION: To prevent improper cooling and thermal damage, do not operate the server unless all bays are populated with either a component or a blank.

To replace the component, reverse the removal procedure.

Eight-bay SFF drive cage backplane (bay 1)

To remove the component:

- Power down the server (on page 29).
- Do one of the following:
 - Open or remove the tower bezel, as needed ("Tower bezel" on page 32).
 - Extend the server from the rack (on page 30).
- Remove the access panel ("Access panel" on page 33).
- Remove fan 5 ("Fan 5" on page 33).
- If installed, remove the BBWC battery pack or the FBWC capacitor pack ("BBWC battery pack or FBWC capacitor pack" on page 35).
- Remove the air baffle ("Air baffle" on page 36).
- Remove any SFF drives installed in bay 1 ("SAS/SATA hard drive" on page 43).
- Disconnect the power and data cables from the eight-bay SFF drive cage in drive cage bay 1.

- Using a T-10 Torx screwdriver, remove the eight-bay SFF drive cage from drive cage bay 1.

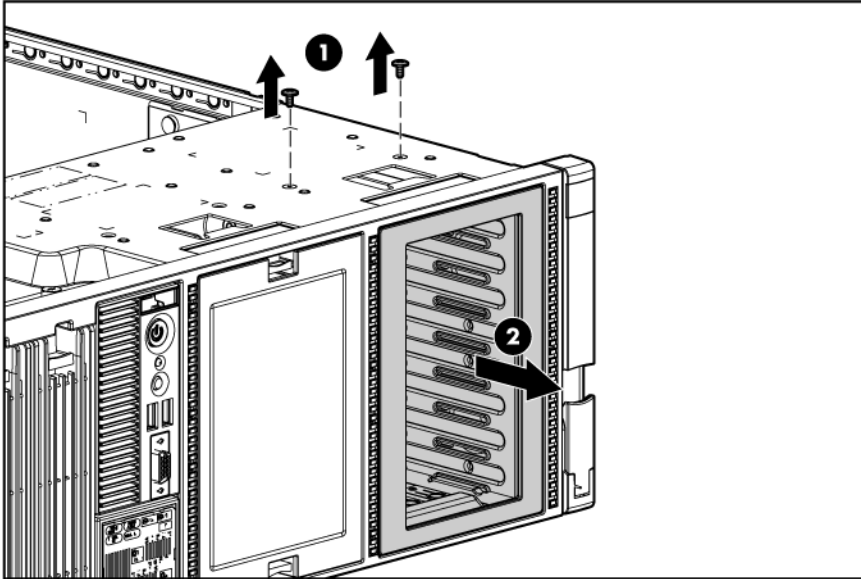

- Using a T-15 Torx screwdriver, remove the backplane from the drive cage. The outer sleeve is not shown for clarity.

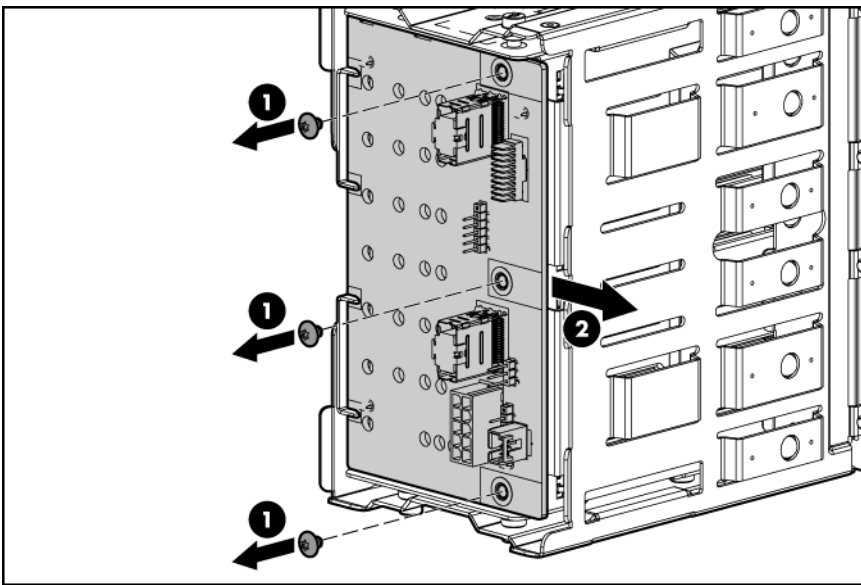

CAUTION: To prevent improper cooling and thermal damage, do not operate the server unless all bays are populated with either a component or a blank.

To replace the component, reverse the removal procedure.

Eight-bay SFF drive cage backplane (bay 2)

To remove the component:

- Power down the server (on page 29).
- Do one of the following:
 - Open or remove the tower bezel, as needed ("Tower bezel" on page 32).

- o Extend the server from the rack (on page 30).
- 3. Remove the access panel ("Access panel" on page 33).
- 4. Remove fan 5 ("Fan 5" on page 33).
- 5. If installed, remove the BBWC battery pack or the FBWC capacitor pack ("BBWC battery pack or FBWC capacitor pack" on page 35).
- 6. Remove the air baffle ("Air baffle" on page 36).
- 7. Remove the fan cage (on page 37).
- 8. Disconnect the data and power cables from the eight-bay SFF drive cage in bay 2.
- 9. Remove any SFF drives installed in bay 2 ("SAS/SATA hard drive" on page 43).
- 10. Using a T-15 Torx screwdriver, remove the eight-bay SFF drive cage from bay 2.

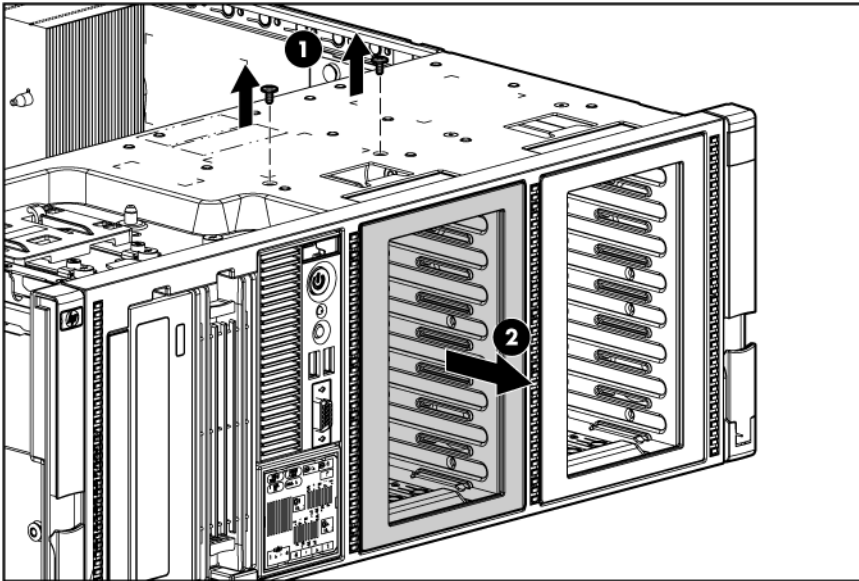

- 11. Using a T-15 Torx screwdriver, remove the backplane from the drive cage.
The outer sleeve is not shown for clarity.

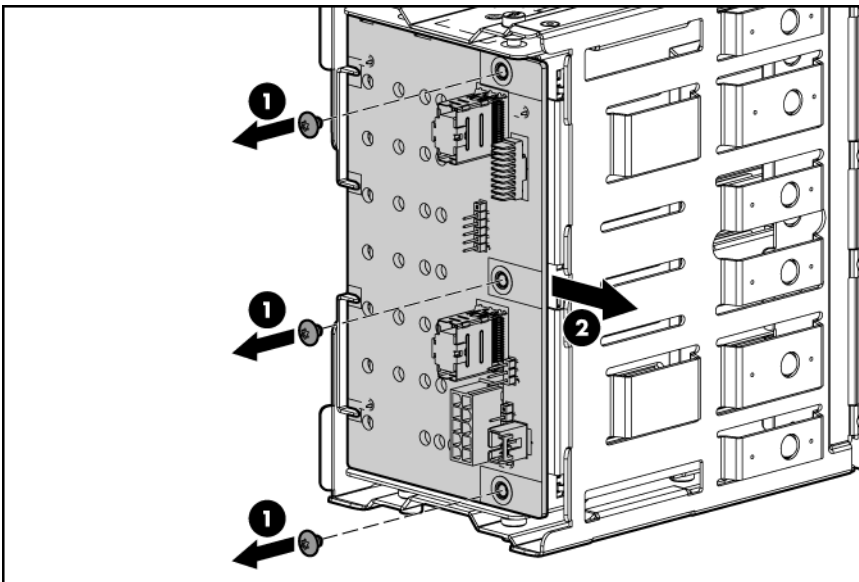



CAUTION: To prevent improper cooling and thermal damage, do not operate the server unless all bays are populated with either a component or a blank.

To replace the component, reverse the removal procedure.

Eight-bay SFF drive cage backplane (bay 3)

To remove the component:

1. Power down the server (on page 29).
2. Do one of the following:
 - o Open or remove the tower bezel, as needed ("Tower bezel" on page 32).
 - o Extend the server from the rack (on page 30).
3. Remove the access panel ("Access panel" on page 33).
4. Remove fan 5 ("Fan 5" on page 33).
5. If installed, remove the BBWC battery pack or the FBWC capacitor pack ("BBWC battery pack or FBWC capacitor pack" on page 35).
6. Remove the air baffle ("Air baffle" on page 36).
7. Remove the fan cage (on page 37).
8. Disconnect the data and power cables from the eight-bay SFF drive cage in bay 3.
9. Remove any SFF drives installed in bay 3 ("SAS/SATA hard drive" on page 43).
10. Remove the locking brackets.

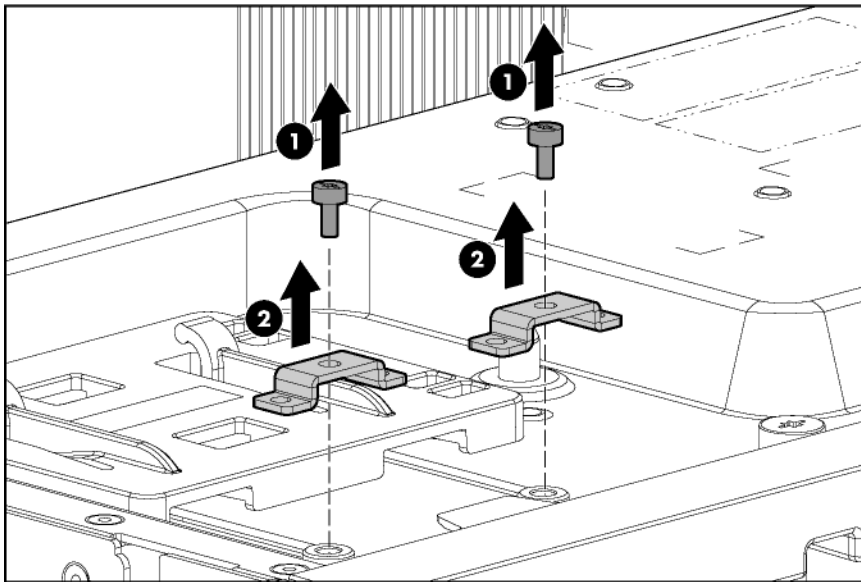

11. Remove the eight-bay SFF drive cage from bay 3.

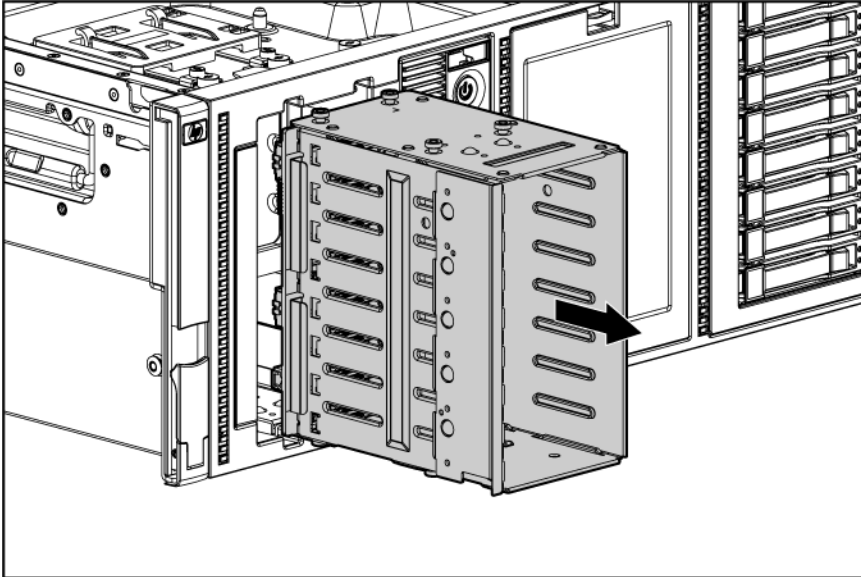

12. Using a T-15 Torx screwdriver, remove the backplane from the drive cage.

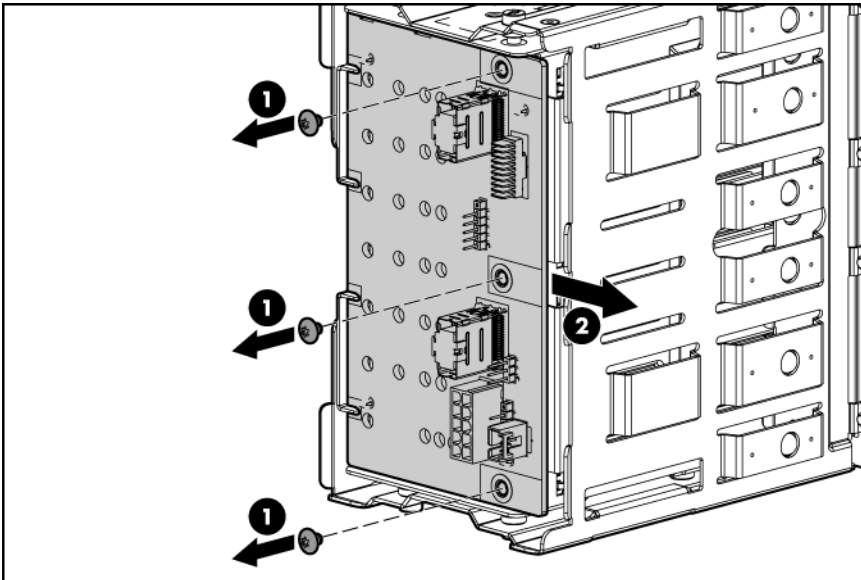

CAUTION: To prevent improper cooling and thermal damage, do not operate the server unless all bays are populated with either a component or a blank.

To replace the component, reverse the removal procedure.

Power supply

CAUTION: To prevent improper cooling and thermal damage, do not operate the server unless all bays are populated with either a component or a blank.

To remove the component:

1. Determine how many hot-plug power supplies are installed:

- If only one hot-plug power supply is installed, power down and remove the power cord from the server ("[Power down the server](#)" on page 29).
 - If more than one hot-plug power supply is installed, continue with the next step.
2. Access the product rear panel (on page 31).
 3. Disconnect the power cord from the AC power source.
 4. Disconnect the power cord from the power supply.
 5. Remove the power supply.

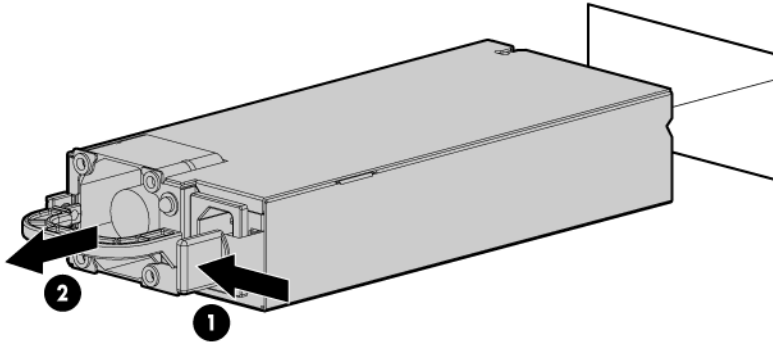

To replace the component, reverse the removal procedure.

Heatsink

To remove the component:

1. Power down the server (on page 29).
2. Do one of the following:
 - Open or remove the tower bezel, as needed ("[Tower bezel](#)" on page 32).
 - Extend the server from the rack (on page 30).
3. Remove the access panel ("[Access panel](#)" on page 33).
4. Place the tower server on its side.
5. Remove fan 5 ("[Fan 5](#)" on page 33).
6. If installed, remove the BBWC battery pack or the FBWC capacitor pack ("[BBWC battery pack or FBWC capacitor pack](#)" on page 35).
7. Remove the air baffle ("[Air baffle](#)" on page 36).
8. Open the heatsink retaining latches.

9. Remove the heatsink.

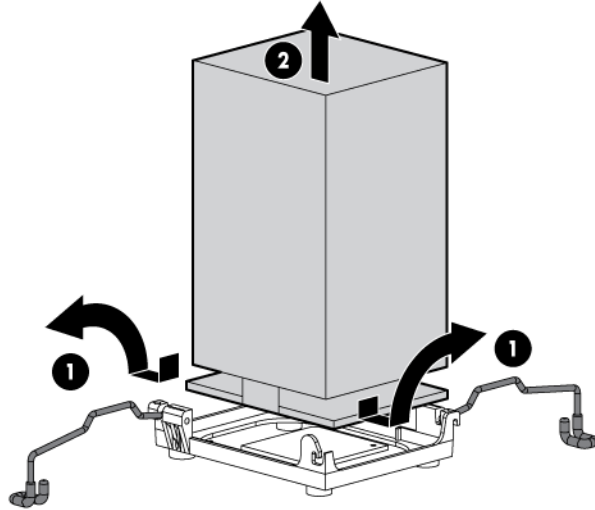

To replace the heatsink:

1. Use the alcohol swab to remove all the existing thermal grease from the processor. Allow the alcohol to evaporate before continuing.
2. Apply all the grease to the top of the processor in one of the following patterns to ensure even distribution.



CAUTION: The heatsink thermal interface media is not reusable and must be replaced if the heatsink is removed from the processor after it has been installed.

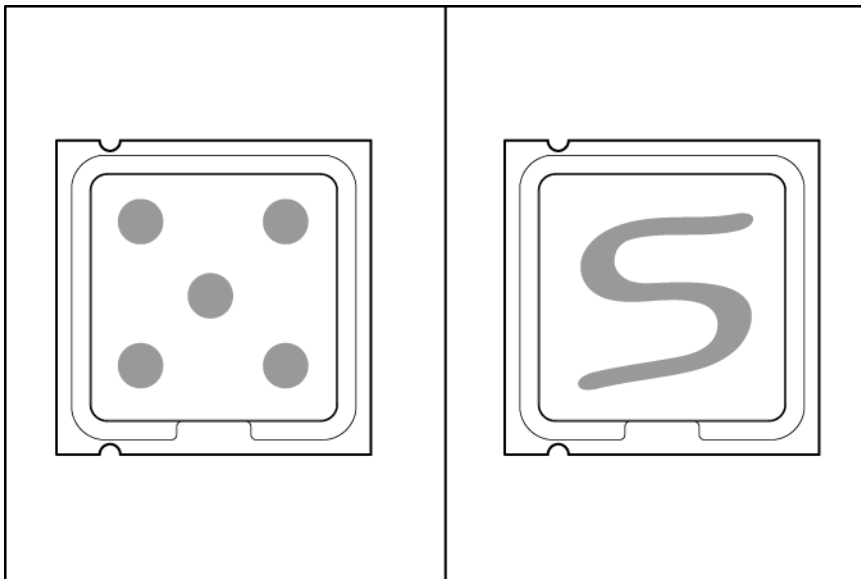

3. Install the heatsink, and close the heatsink retaining latches.

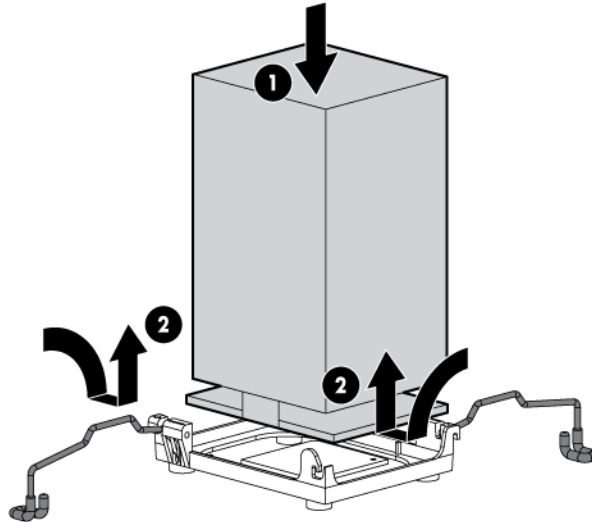



4. Install the air baffle.
5. If removed, install the BBWC battery pack or the FBWC capacitor pack.
6. Install fan 5.
7. Install the access panel.
8. Do one of the following:
 - o Install and lock the bezel.
 - o Slide the server back into the rack.
9. Power up the server.

Processor

The server supports single- and dual-processor operation. With two processors installed, the server supports boot functions through the processor installed in processor socket 1. However, if processor 1 fails, the system attempts to boot from processor 2 and provides a processor failure message.

The server uses embedded PPMs to provide power to each processor.

 **CAUTION:** To avoid damage to the processor and system board, only authorized personnel should attempt to replace or install the processor in this server.

 **CAUTION:** To avoid damage to the processor:

- Handle the processor only by the edges.
- Do not touch the bottom of the processor, especially the contact area.

 **IMPORTANT:** Processor socket 1 must always be populated. If processor socket 1 is empty, the server halts during POST.

To remove the component:

1. Update the system ROM.

Locate and download the latest ROM version from the HP website (<http://www.hp.com/support>). Follow the instructions on the website to update the system ROM.

2. Power down the server (on page 29).
3. Do one of the following:
 - o Open or remove the tower bezel, as needed ("Tower bezel" on page 32).
 - o Extend the server from the rack (on page 30).
4. Remove the access panel ("Access panel" on page 33).
5. Place the tower server on its side.
6. Remove fan 5 ("Fan 5" on page 33).
7. If installed, remove the BBWC battery pack or the FBWC capacitor pack ("BBWC battery pack or FBWC capacitor pack" on page 35).
8. Remove the air baffle ("Air baffle" on page 36).
9. Remove the heatsink ("Heatsink" on page 55).
10. Open the processor retaining latch and the processor socket retaining bracket.

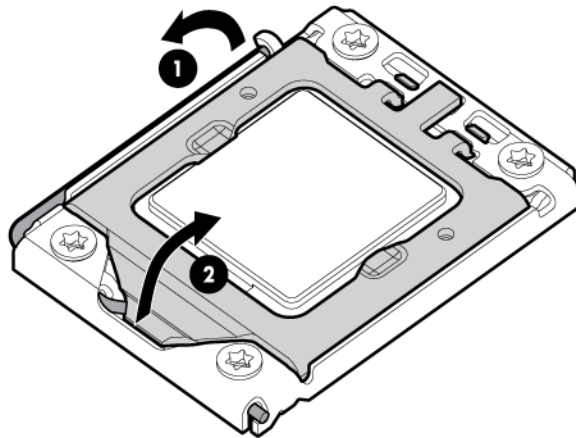

11. Using your fingers, remove the failed processor.

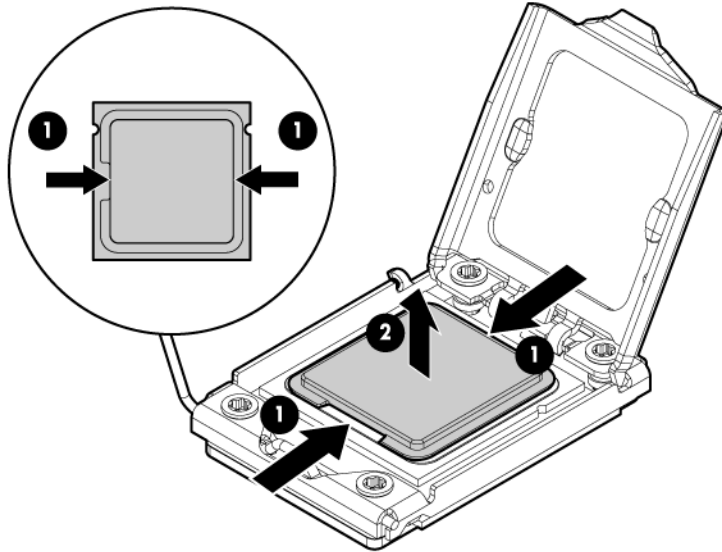

To replace a processor:



IMPORTANT: Be sure the processor remains inside the processor installation tool.

1. If the processor has separated from the installation tool, carefully re-insert the processor in the tool.

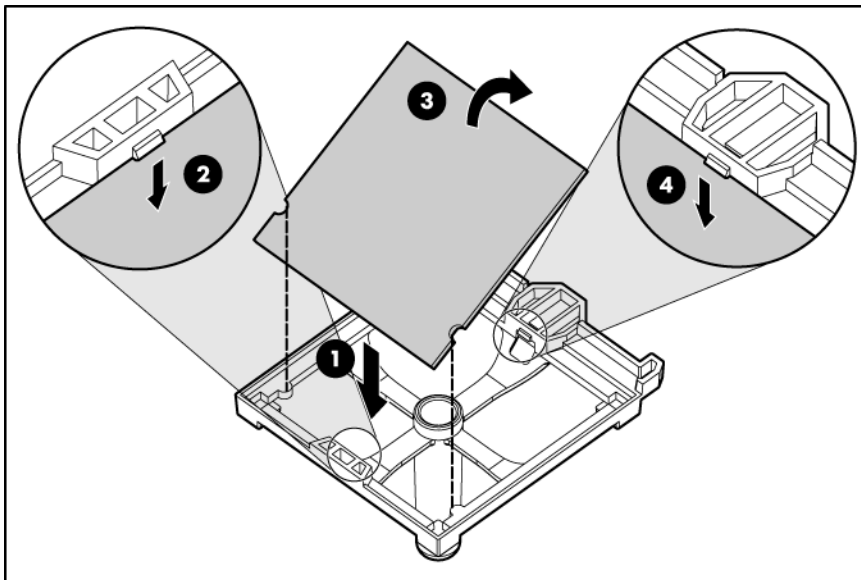

2. Align the processor installation tool with the socket and install the spare processor.



CAUTION: The processor is designed to fit one way into the socket. Use the alignment guides on the processor and socket to properly align the processor with the socket. Refer to the server hood label for specific instructions.

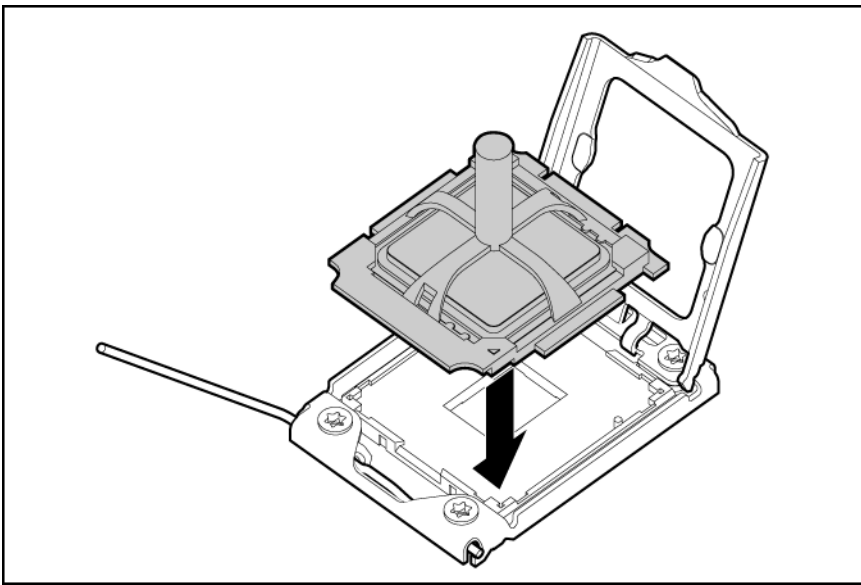

3. Press down firmly until the processor installation tool clicks and separates from the processor, and then remove the processor installation tool.

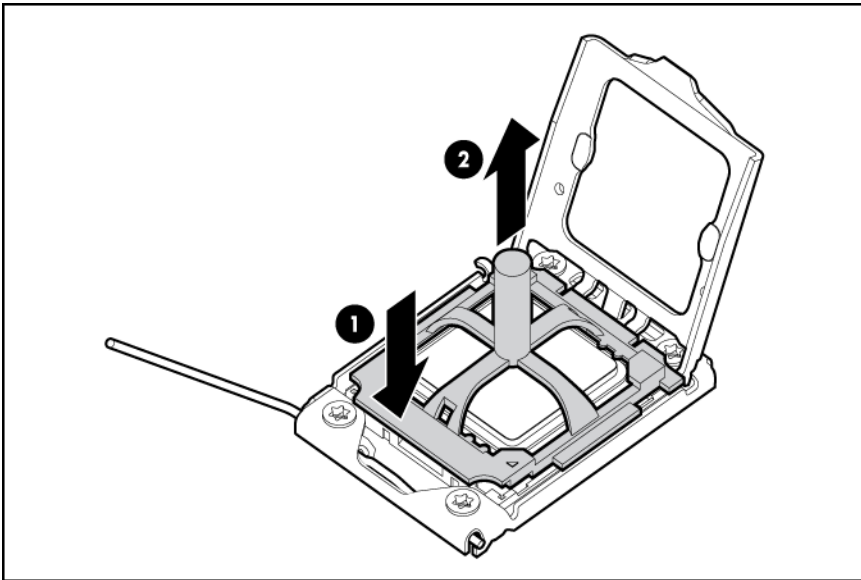

4. Close the processor retaining latch and the processor socket retaining bracket.

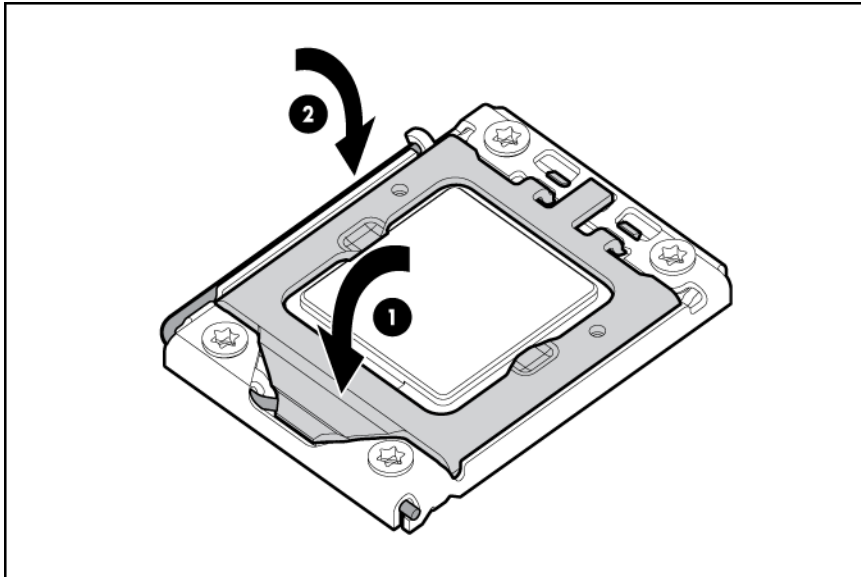

5. Clean the old thermal grease from the heatsink with the alcohol swab. Allow the alcohol to evaporate before continuing.
6. Apply all the grease to the top of the processor in one of the following patterns to ensure even distribution.

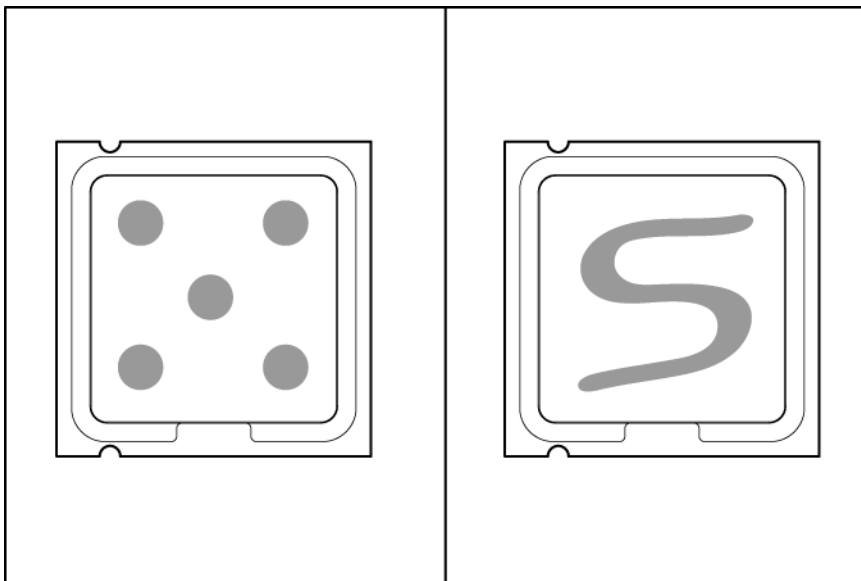

7. Install the heatsink, and then close the heatsink retaining latches.

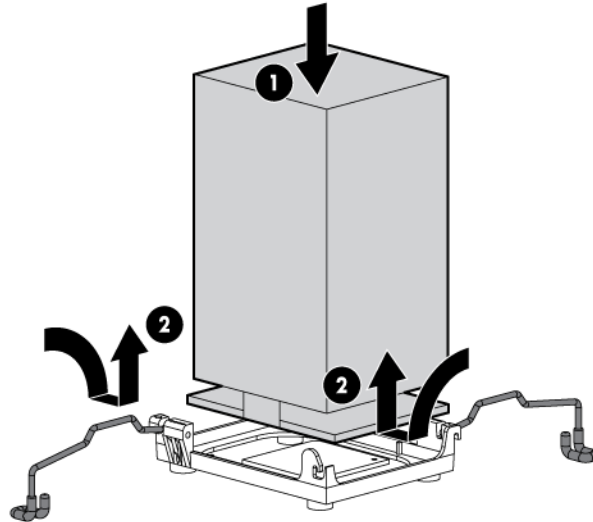

8. Install the air baffle.
9. If removed, install the BBWC battery pack or the FBWC capacitor pack.
10. Install fan 5.
11. Install the access panel.
12. Do one of the following:
 - o Close or install the tower bezel, as needed.
 - o Slide the server back into the rack.
13. Power up the server.

DIMMs



IMPORTANT: This server does not support mixing RDIMMs and UDIMMs. Attempting to mix these two types causes the server to halt during BIOS initialization.

To identify the DIMMs installed in the server, see "DIMM identification (on page 95)."

To remove the component:

1. Power down the server (on page 29).
2. Do one of the following:
 - o Open or remove the tower bezel, as needed ("Tower bezel" on page 32).
 - o Extend the server from the rack (on page 30).
3. Remove the access panel ("Access panel" on page 33).
4. Remove fan 5 ("Fan 5" on page 33).
5. If installed, remove the BBWC battery pack or the FBWC capacitor pack ("BBWC battery pack or FBWC capacitor pack" on page 35).
6. Remove the air baffle ("Air baffle" on page 36).
7. Remove the fan cage (on page 37).

8. Remove the DIMM.

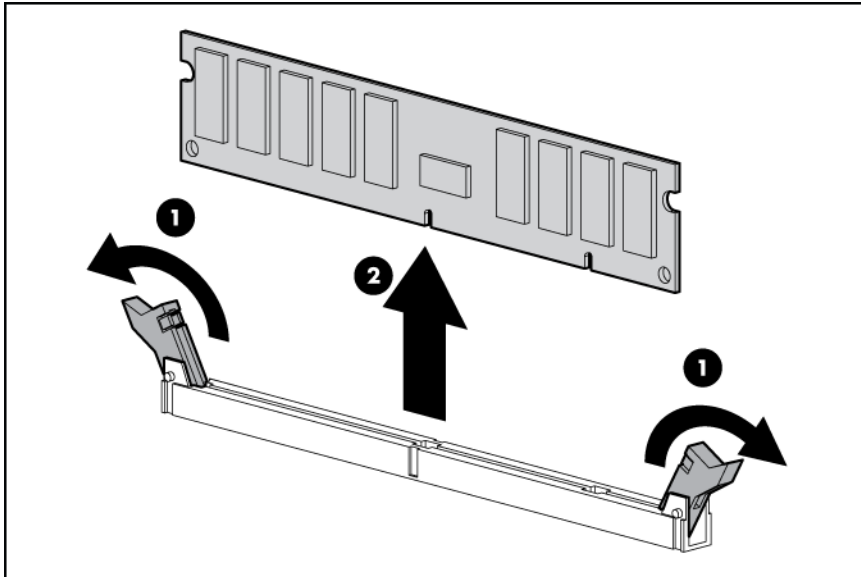

To replace the component, reverse the removal procedure.

For DIMM configuration information, see the server user guide.

PCIe expansion board

To remove the component:

1. Power down the server (on page 29).
2. Do one of the following:
 - o Open or remove the tower bezel, as needed ("Tower bezel" on page 32).
 - o Extend the server from the rack (on page 30).
3. Remove the access panel ("Access panel" on page 33).
4. Disconnect any external and internal cables from the PCIe expansion board.

5. Open the expansion board retainer.

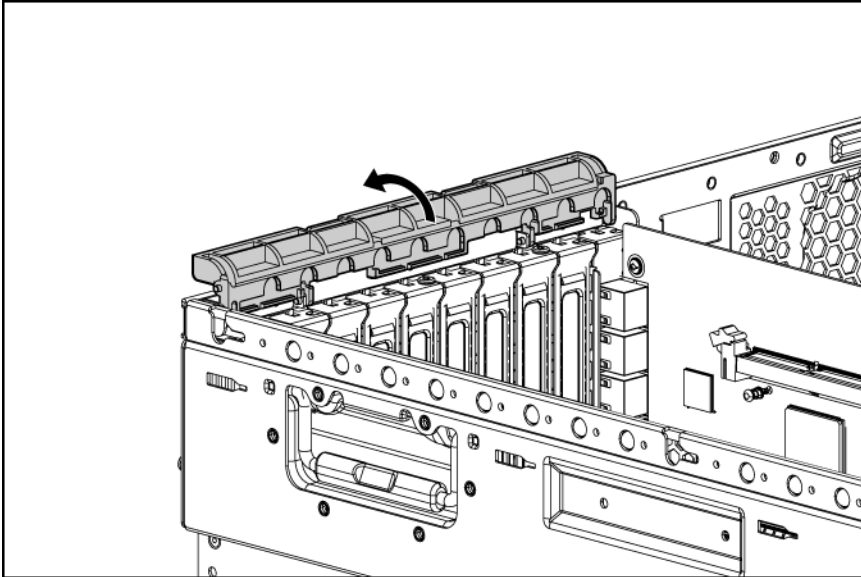

6. Remove the expansion board.

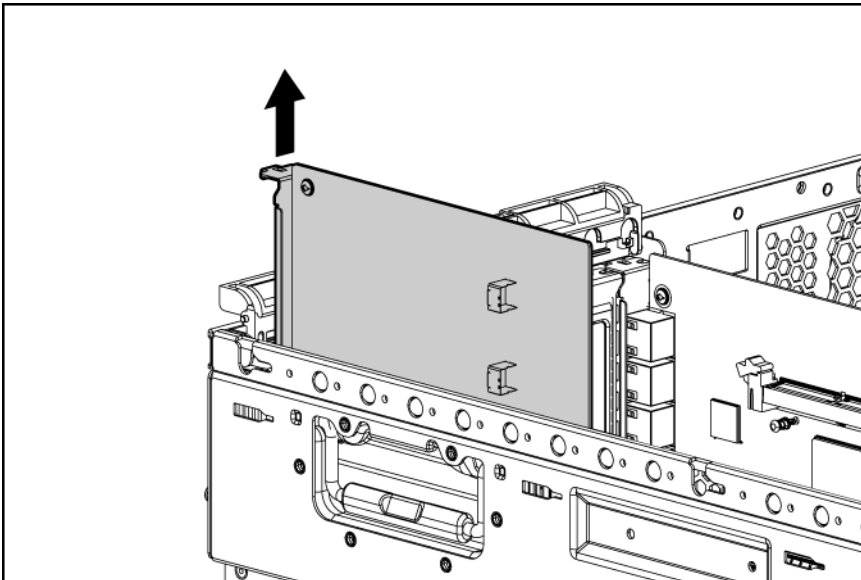

To replace the component, reverse the removal procedure.

HP NC375i adapter

To remove the component:

1. Power down the server (on page 29).
2. Do one of the following:
 - o Open or remove the tower bezel, as needed ("Tower bezel" on page 32).
 - o Extend the server from the rack (on page 30).
3. Remove the access panel ("Access panel" on page 33).
4. Remove fan 5 ("Fan 5" on page 33).

5. If installed, remove the BBWC battery pack or the FBWC capacitor pack ("[BBWC battery pack or FBWC capacitor pack](#)" on page 35).
6. Remove the air baffle ("[Air baffle](#)" on page 36).
7. Disconnect the network cable.
8. If the HP NC524SFP Dual Port 10GbE Module is installed, remove the retaining screw.

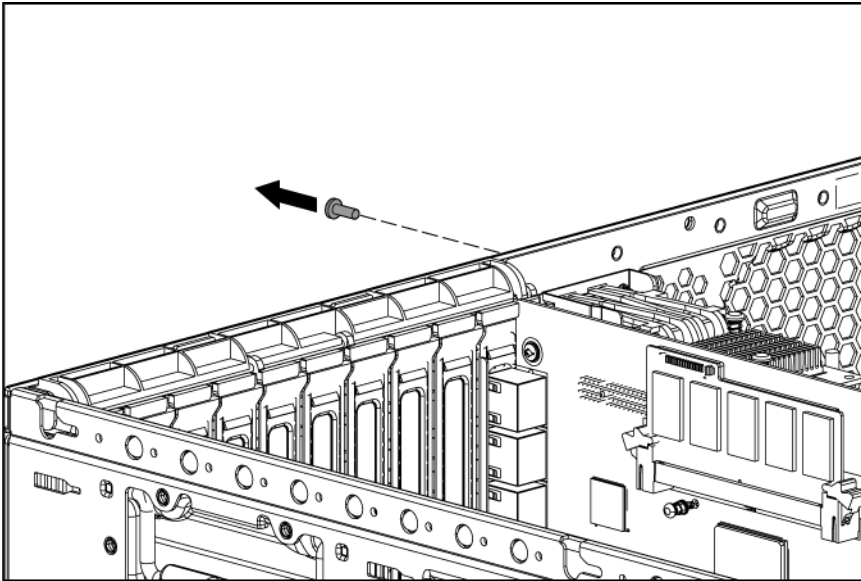

9. Open the expansion board slot retainer.
10. Remove the HP NC375i adapter from expansion slot 10.

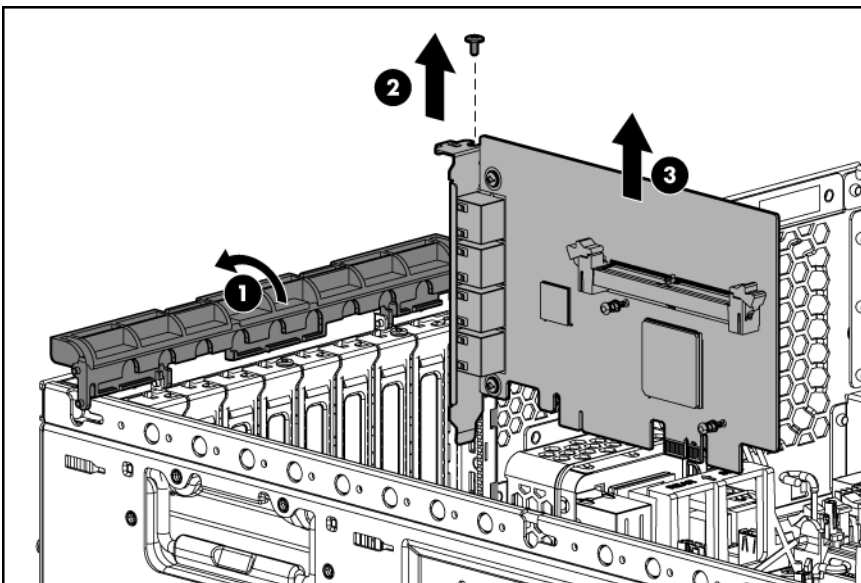

11. Remove the mini-DIMM, if installed.

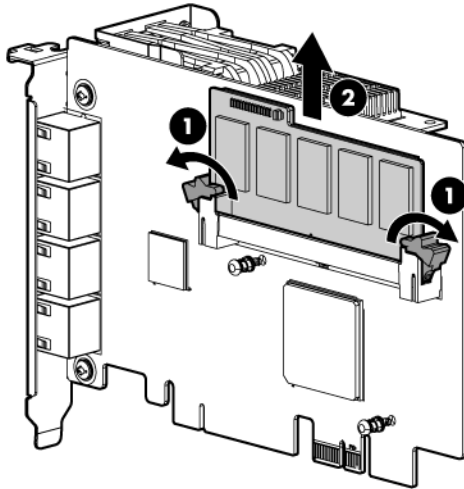

12. Remove the HP NC524SFP Dual Port 10GbE Module ("HP NC524SFP Dual Port 10GbE Module" on page 66), if installed.

To replace the component, reverse the removal procedure.

HP NC524SFP Dual Port 10GbE Module

To remove the component:

1. Power down the server (on page 29).
2. Disconnect the network cables.
3. Do one of the following:
 - o Open or remove the tower bezel, as needed ("Tower bezel" on page 32).
 - o Extend the server from the rack (on page 30).
4. Remove the access panel ("Access panel" on page 33).
5. Remove fan 5 ("Fan 5" on page 33).
6. If installed, remove the BBWC battery pack or the FBWC capacitor pack ("BBWC battery pack or FBWC capacitor pack" on page 35).
7. Remove the air baffle ("Air baffle" on page 36).
8. Using a T-15 Torx screwdriver, remove the retaining screw.

Save the retaining screw.

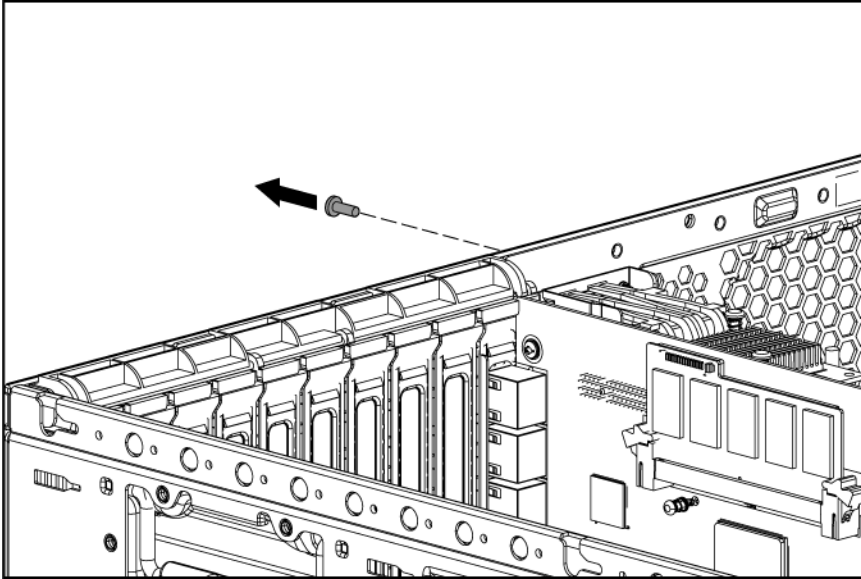

9. Open the expansion board slot retainer.
10. Remove the HP NC375i adapter ("HP NC375i adapter" on page 64) from expansion slot 10.
11. Remove the HP NC524SFP module from the HP NC375i adapter.

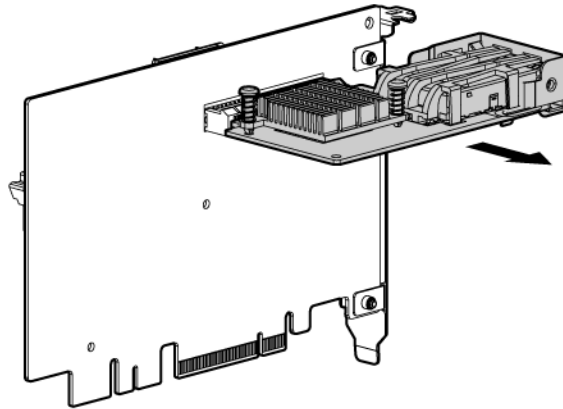

To replace the component, reverse the removal procedure.

Systems Insight Display

To remove the component:

1. Power down the server (on page 29).
2. Do one of the following:
 - Open or remove the tower bezel, as needed ("Tower bezel" on page 32).
 - Extend the server from the rack (on page 30).

3. Remove the access panel ("[Access panel](#)" on page [33](#)).
4. Remove fan 5 ("[Fan 5](#)" on page [33](#)).
5. If installed, remove the BBWC battery pack or the FBWC capacitor pack ("[BBWC battery pack or FBWC capacitor pack](#)" on page [35](#)).
6. Remove the air baffle ("[Air baffle](#)" on page [36](#)).
7. Remove the fan cage (on page [37](#)).
8. Extend the Systems Insight Display from the chassis.
The cages, blanks, and drives are not shown for clarity.

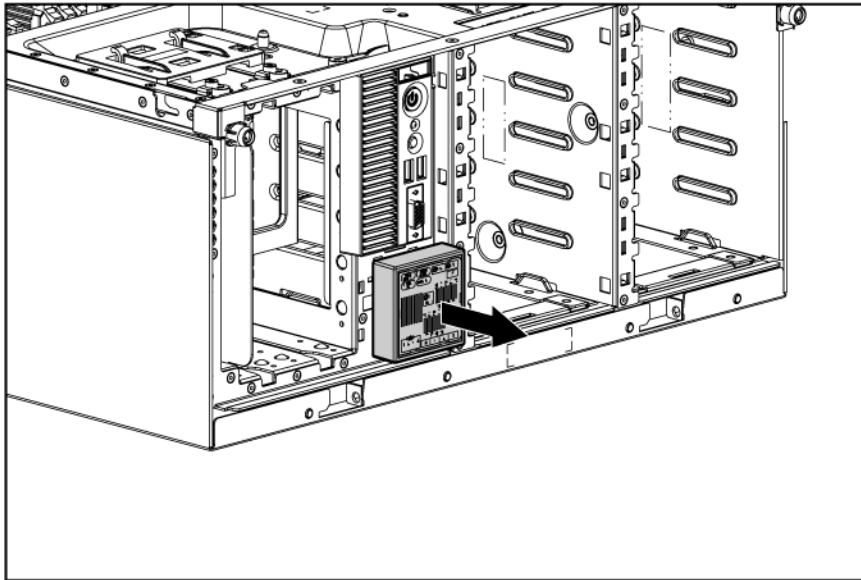

9. Disconnect the System Insight Display cables from the Systems Insight Display.
 10. Remove the Systems Insight Display.
- To replace the component, reverse the removal procedure.

Systems Insight Display cables

To remove the component:

1. Power down the server (on page [29](#)).
2. Do one of the following:
 - o Open or remove the tower bezel, as needed ("[Tower bezel](#)" on page [32](#)).
 - o Extend the server from the rack (on page [30](#)).
3. Remove the access panel ("[Access panel](#)" on page [33](#)).
4. Remove fan 5 ("[Fan 5](#)" on page [33](#)).
5. If installed, remove the BBWC battery pack or the FBWC capacitor pack ("[BBWC battery pack or FBWC capacitor pack](#)" on page [35](#)).
6. Remove the air baffle ("[Air baffle](#)" on page [36](#)).
7. Remove the fan cage (on page [37](#)).
8. Remove the Systems Insight Display ("[Systems Insight Display](#)" on page [67](#)).
9. Remove the Systems Insight Display cables from the system board.

To replace the component, reverse the removal procedure.

I/O bezel

To remove the component:

1. Power down the server (on page 29).
2. Do one of the following:
 - o Open or remove the tower bezel, as needed ("Tower bezel" on page 32).
 - o Extend the server from the rack (on page 30).
3. Remove the access panel ("Access panel" on page 33).
4. Remove fan 5 ("Fan 5" on page 33).
5. If installed, remove the BBWC battery pack or the FBWC capacitor pack ("BBWC battery pack or FBWC capacitor pack" on page 35).
6. Remove the air baffle ("Air baffle" on page 36).
7. Remove the fan cage (on page 37).
8. Extend the I/O bezel from the chassis.

The cages, blanks, and drives are not shown for clarity.

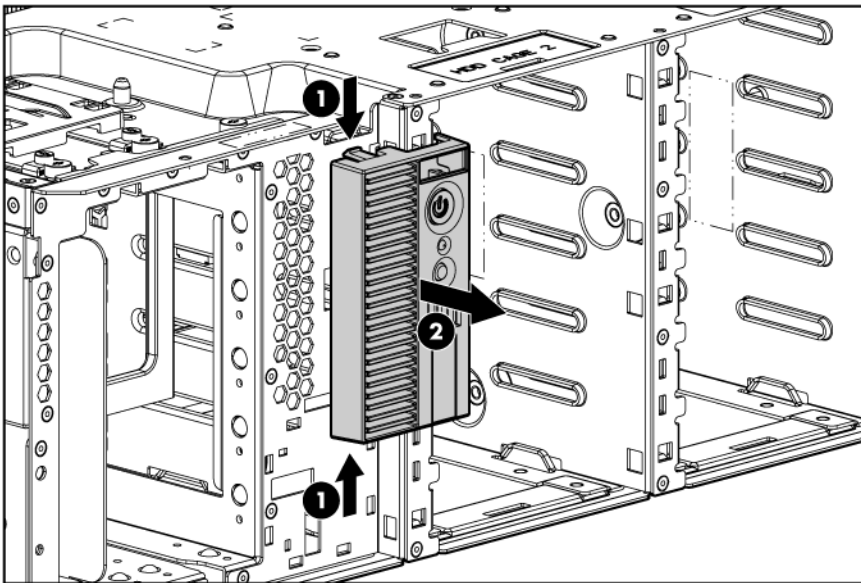

9. Disconnect the cables from the I/O bezel.
10. Remove the I/O bezel.

To replace the component, reverse the removal procedure.

I/O bezel cables

To remove the component:

1. Power down the server (on page 29).
2. Do one of the following:
 - o Open or remove the tower bezel, as needed ("Tower bezel" on page 32).

- Extend the server from the rack (on page 30).
- 3. Remove the access panel ("Access panel" on page 33).
- 4. Remove fan 5 ("Fan 5" on page 33).
- 5. If installed, remove the BBWC battery pack or the FBWC capacitor pack ("BBWC battery pack or FBWC capacitor pack" on page 35).
- 6. Remove the air baffle ("Air baffle" on page 36).
- 7. Remove the I/O bezel ("I/O bezel" on page 69).
- 8. Disconnect the I/O bezel cables from the system board.

To replace the component, reverse the removal procedure.

Battery

If the server no longer automatically displays the correct date and time, you may need to replace the battery that provides power to the real-time clock. Under normal use, battery life is 5 to 10 years.



WARNING: The computer contains an internal lithium manganese dioxide, a vanadium pentoxide, or an alkaline battery pack. A risk of fire and burns exists if the battery pack is not properly handled. To reduce the risk of personal injury:

- Do not attempt to recharge the battery.
- Do not expose the battery to temperatures higher than 60°C (140°F).
- Do not disassemble, crush, puncture, short external contacts, or dispose of in fire or water.
- Replace only with the spare designated for this product.

To remove the component:

1. Power down the server (on page 29).
2. Do one of the following:
 - Open or remove the tower bezel, as needed ("Tower bezel" on page 32).
 - Extend the server from the rack (on page 30).
3. Remove the access panel ("Access panel" on page 33).
4. Remove fan 5 ("Fan 5" on page 33).
5. If installed, remove the BBWC battery pack or the FBWC capacitor pack ("BBWC battery pack or FBWC capacitor pack" on page 35).
6. Remove the air baffle ("Air baffle" on page 36).

7. Remove the battery.

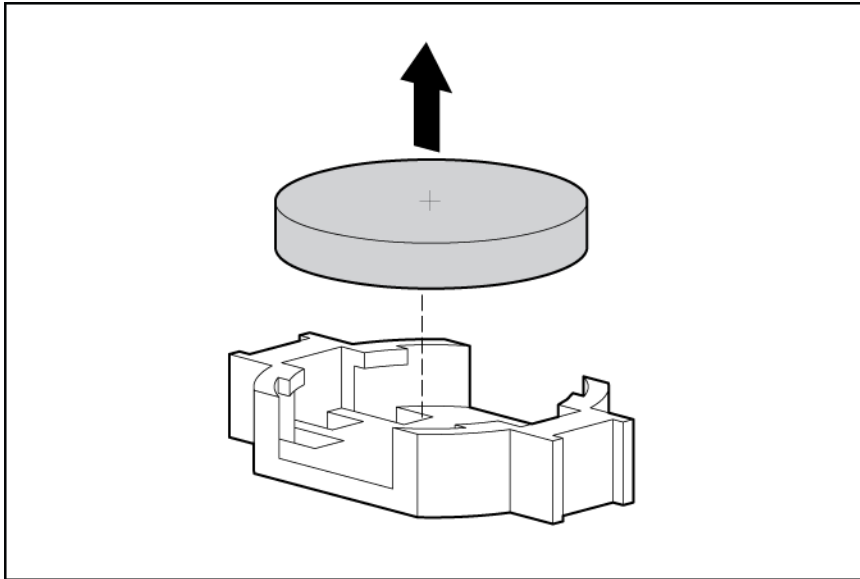

IMPORTANT: Replacing the system board battery resets the system ROM to its default configuration. After replacing the battery, reconfigure the system through RBSU.

To replace the component, reverse the removal procedure.

For more information about battery replacement or proper disposal, contact an authorized reseller or an authorized service provider.

HP Trusted Platform Module

The TPM is not a customer-removable part.



CAUTION: Any attempt to remove an installed TPM from the system board breaks or disfigures the TPM security rivet. Upon locating a broken or disfigured rivet on an installed TPM, administrators should consider the system compromised and take appropriate measures to ensure the integrity of the system data.

If you suspect a TPM board failure, leave the TPM installed and remove the system board ("System board" on page 71). Contact an HP authorized service provider for a replacement system board and TPM board.

System board



IMPORTANT: If replacing the system board or clearing NVRAM, you must re-enter the server serial number through RBSU.

To remove the component:

1. Power down the server (on page 29).
2. Do one of the following:
 - o Open or remove the tower bezel, as needed ("Tower bezel" on page 32).
 - o Remove the server from the rack (on page 29).
3. Remove the access panel ("Access panel" on page 33).

4. Remove all expansion boards ("PCIe expansion board" on page 63).
5. Remove the HP NC375i adapter ("HP NC375i adapter" on page 64).
6. Remove fan 5 ("Fan 5" on page 33).
7. If installed, remove the BBWC battery pack or the FBWC capacitor pack ("BBWC battery pack or FBWC capacitor pack" on page 35).
8. Remove the air baffle ("Air baffle" on page 36).
9. Remove the fan cage (on page 37).
10. Remove all DIMMs ("DIMMs" on page 62).
11. Disconnect all cables connected to the system board.
12. Remove the heatsink ("Heatsink" on page 55).

-
- △ **CAUTION:** To avoid damage to the processor:
- Handle the processor only by the edges.
 - Do not touch the bottom of the processor, especially the contact area.
-

- △ **CAUTION:** To avoid damage to the system board:
- Do not touch the processor socket contacts.
 - Always install the processor socket cover after removing the processor from the socket.
 - Do not tilt or slide the processor when lowering the processor into the socket.
-

- △ **CAUTION:** Removal of the processor or heatsink renders the thermal layer between the processor and heatsink useless. Clean the component with the provided alcohol swab, then add thermal grease.
-

13. Open the processor retaining latch and the processor socket retaining bracket.

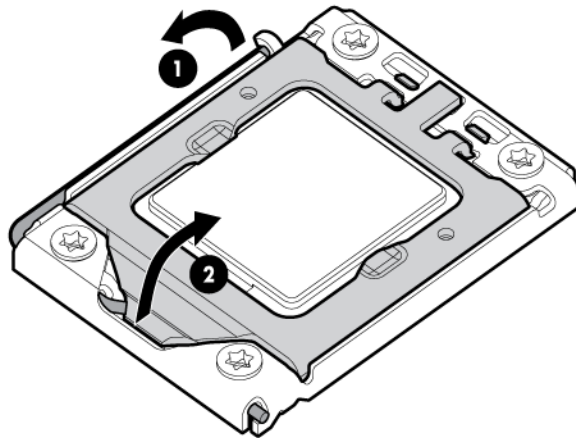

-
- △ **CAUTION:** To avoid damage to the processor:
- Handle the processor only by the edges.
 - Do not touch the bottom of the processor, especially the contact area.
-

14. Using your fingers, remove the processor from the failed system board.

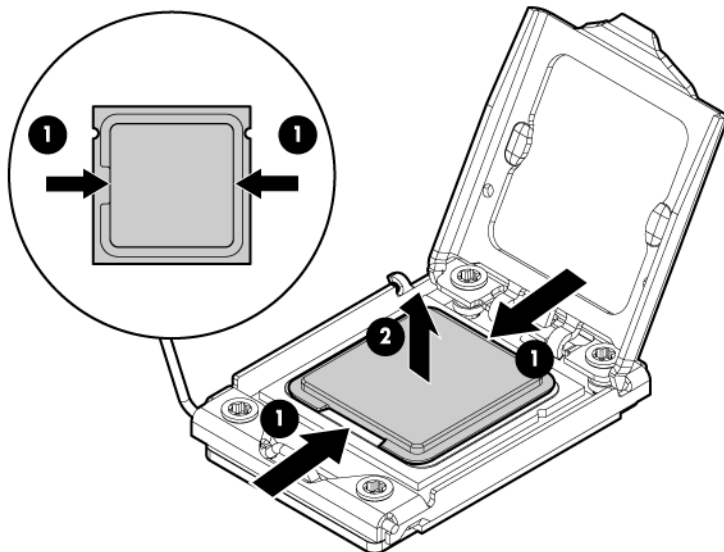

△ **CAUTION:** To avoid damage to the system board:

- Do not touch the processor socket contacts.
- Always install the processor socket cover after removing the processor from the socket.
- Do not tilt or slide the processor when lowering the processor into the socket.

15. Loosen the two system board thumbscrews.
16. Using the system board tray handles, slide the tray forward and remove the failed system board.

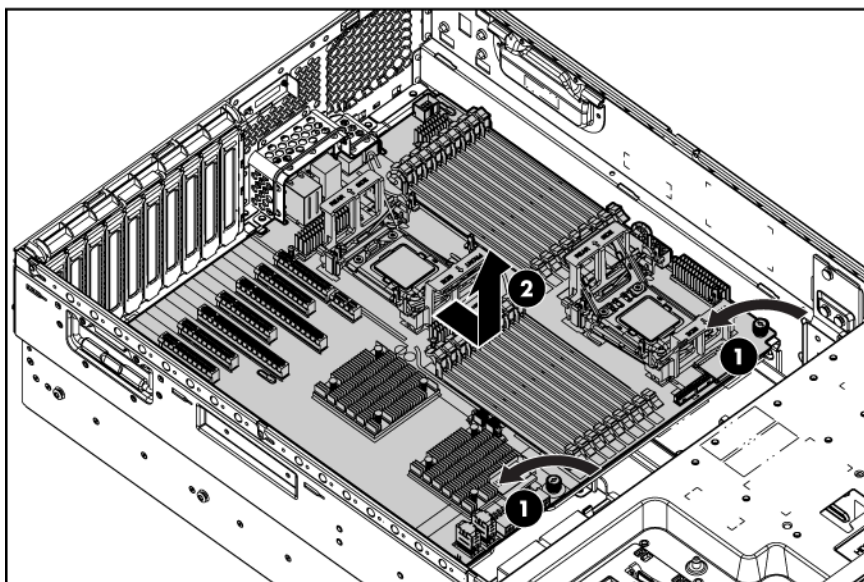

To replace the component:

1. Install the spare system board in the server before installing the processor.

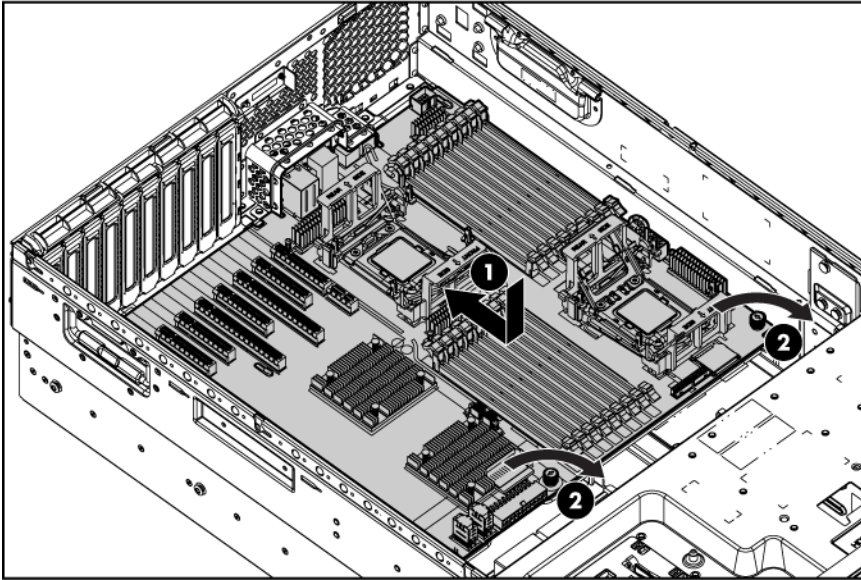

2. Prepare the processor socket on the spare system board:
 - a. Open the processor retaining latch and the processor socket retaining bracket.
 - b. Remove the processor socket protective cover.

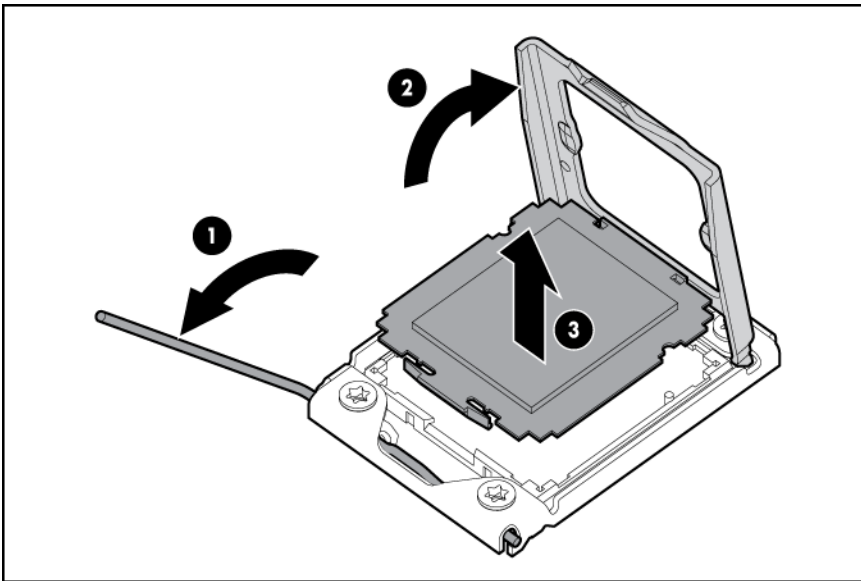

3. Install the processor socket cover onto the processor socket of the failed system board.
4. Install the processor on the spare system board.

△ **CAUTION:** The processor is designed to fit one way into the socket. Use the alignment guides on the processor and socket to properly align the processor with the socket. Refer to the server hood label for specific instructions.

△ **CAUTION:** Always install the processor parallel to the system board to avoid damage to the pins.

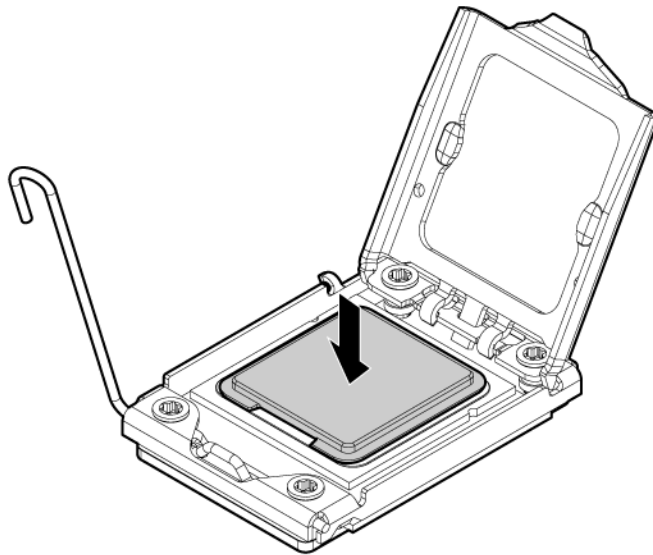

5. Close the processor retaining latch and the processor socket retaining bracket.

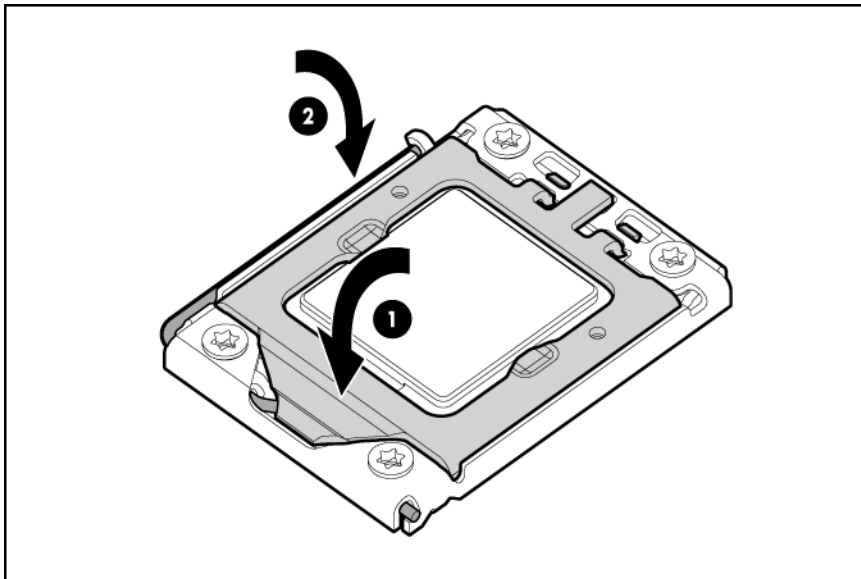

6. Clean the old thermal grease from the heatsink and the top of the processor with the alcohol swab. Allow the alcohol to evaporate before continuing.

7. Apply all the grease to the top of the processor in one of the following patterns to ensure even distribution.

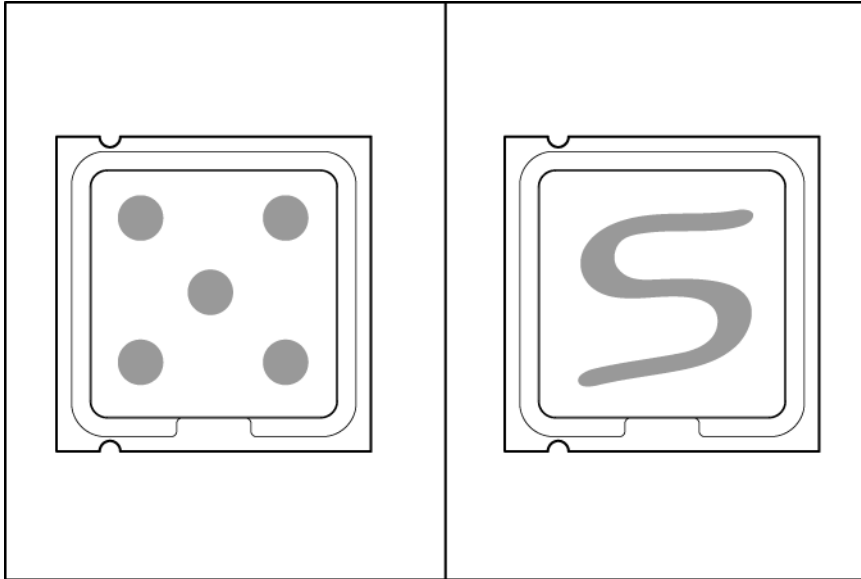

8. Install the heatsink.
9. Close the heatsink locking levers.

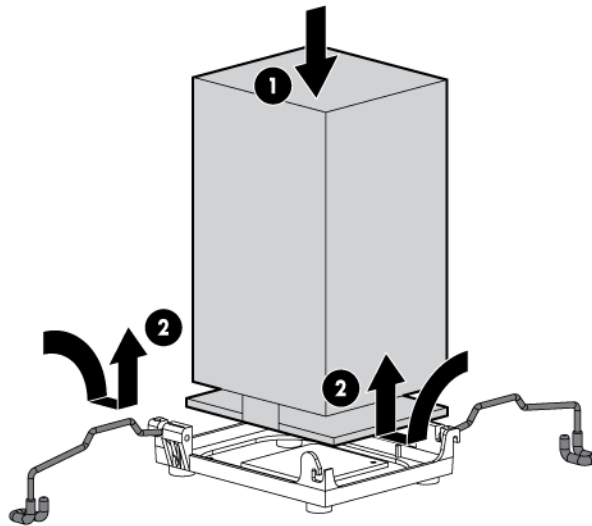

IMPORTANT: Install all components with the same configuration that was used on the failed system board.

10. Install all components removed from the failed system board.
11. Connect the cables.
12. Install the air baffle.
13. If removed, install the BBWC battery pack or the FBWC capacitor pack.
14. Install fan 5.
15. Install the access panel.
16. Do one of the following:

- Close or install the tower bezel, as needed.
 - Install the server in the rack.
17. Power up the server.

After you replace the system board, you must re-enter the server serial number and the product ID.

1. During the server startup sequence, press the **F9** key to access RBSU.
2. Select the **Advanced Options** menu.
3. Select **Service Options**.
4. Select **Serial Number**. The following warnings appear:
WARNING! WARNING! WARNING! The serial number is loaded into the system during the manufacturing process and should NOT be modified. This option should only be used by qualified service personnel. This value should always match the serial number sticker located on the chassis.
Warning: The serial number should ONLY be modified by qualified personnel. This value should always match the serial number located on the chassis.
5. Press the **Enter** key to clear the warning.
6. Enter the serial number and press the **Enter** key.
7. Select **Product ID**. The following warning appears:
Warning: The Product ID should ONLY be modified by qualified personnel. This value should always match the Product ID on the chassis.
8. Enter the product ID and press the **Enter** key.
9. Press the **Esc** key to close the menu.
10. Press the **Esc** key to exit RBSU.
11. Press the **F10** key to confirm exiting RBSU. The server automatically reboots.

Power supply backplane

To remove the component:

1. Power down the server (on page 29).
2. Remove the power supplies ("[Power supply](#)" on page 54).
3. Do one of the following:
 - Open or remove the tower bezel, as needed ("[Tower bezel](#)" on page 32).
 - Extend the server from the rack (on page 30).
4. Remove the access panel ("[Access panel](#)" on page 33).
5. Remove fan 5 ("[Fan 5](#)" on page 33).
6. If installed, remove the BBWC battery pack or the FBWC capacitor pack ("[BBWC battery pack or FBWC capacitor pack](#)" on page 35).
7. Remove the air baffle ("[Air baffle](#)" on page 36).
8. Remove the fan cage (on page 37).
9. Disconnect all power supply backplane cables from the drive cages and system board.
10. Remove the power supply backplane.

The cables are not shown for clarity.

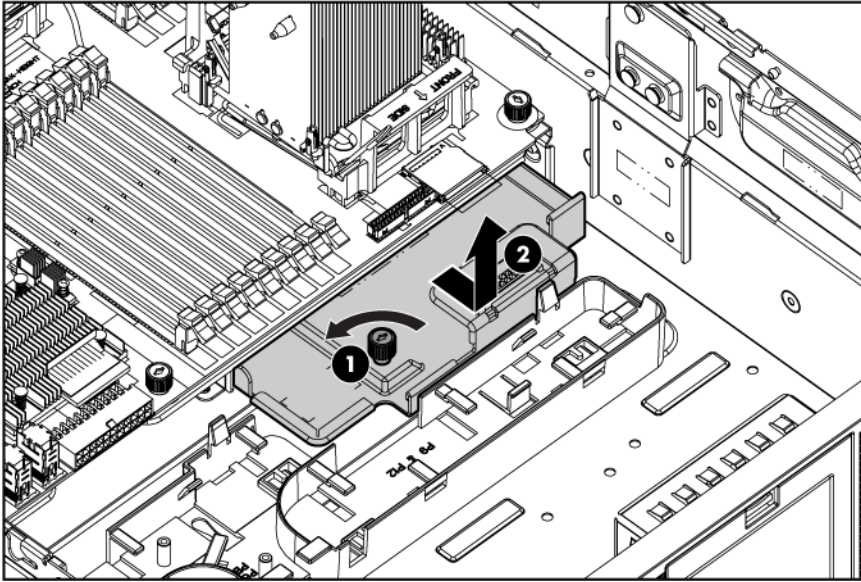

To replace the component, reverse the removal procedure.

Cabling

Storage device cabling guidelines

- △ **CAUTION:** To prevent damage to the equipment, be sure that the server is powered down, all cables are disconnected from the back of the server, and the power cord is disconnected from the grounded (earthed) AC outlet before installing devices.
- △ **CAUTION:** To prevent damage to electrical components, properly ground the server before beginning any installation procedure. Improper grounding can cause electrostatic discharge.

Eight-bay SFF drive cage cabling

- Drive cage bay 1

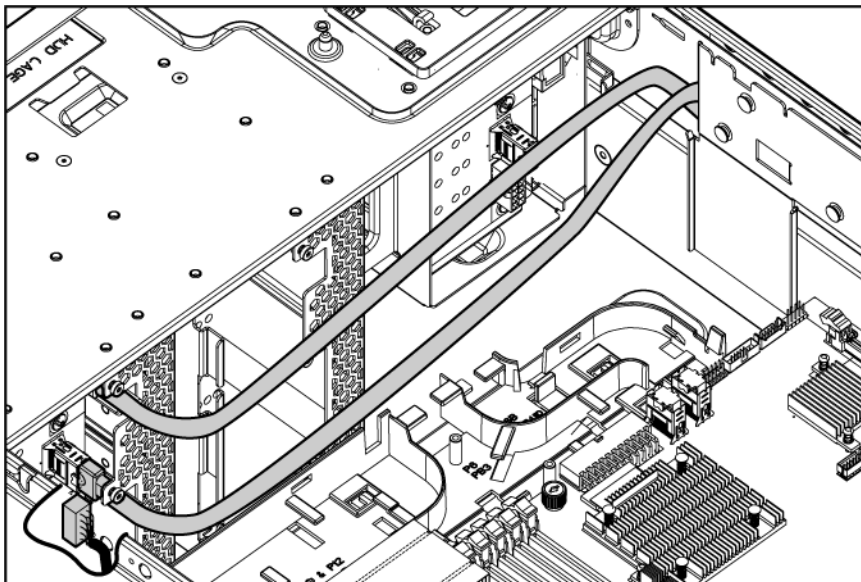

- Drive cage bay 2

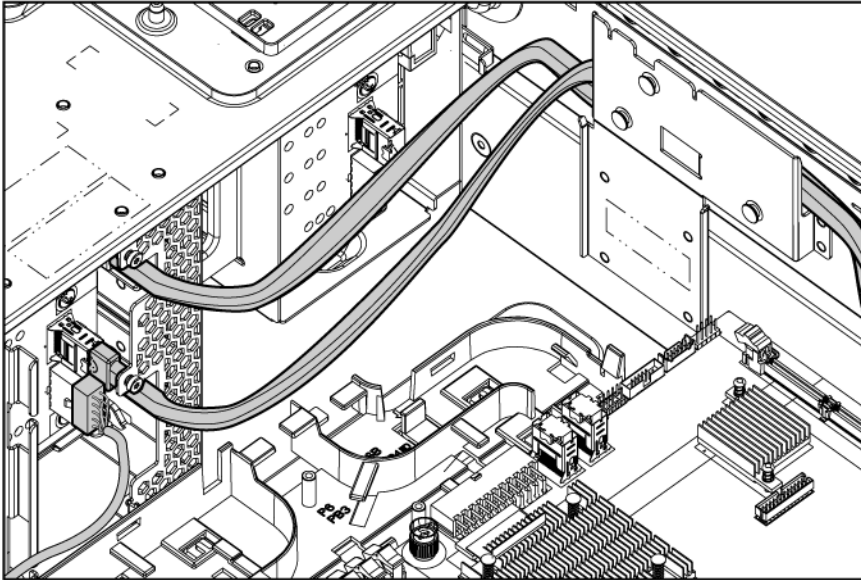

- Drive cage bay 3

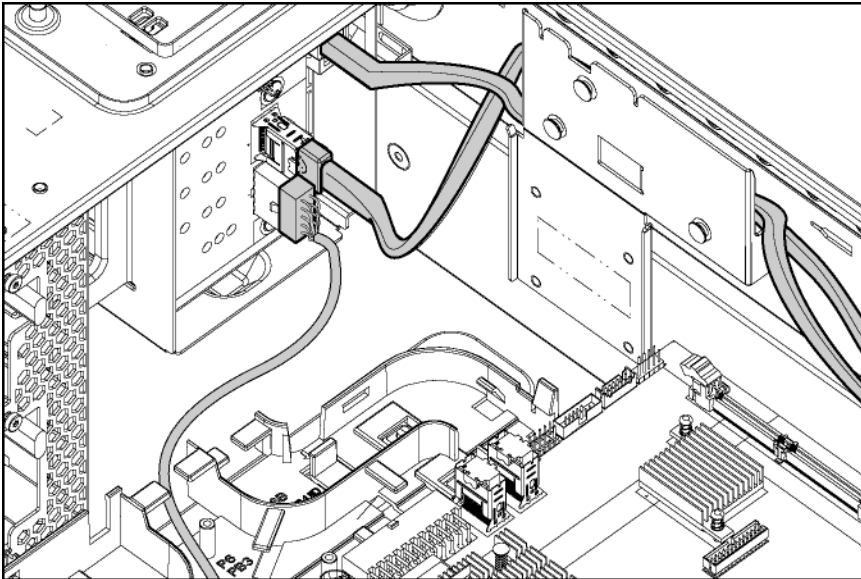

Six-bay LFF backplane cabling

- Drive cage bay 1

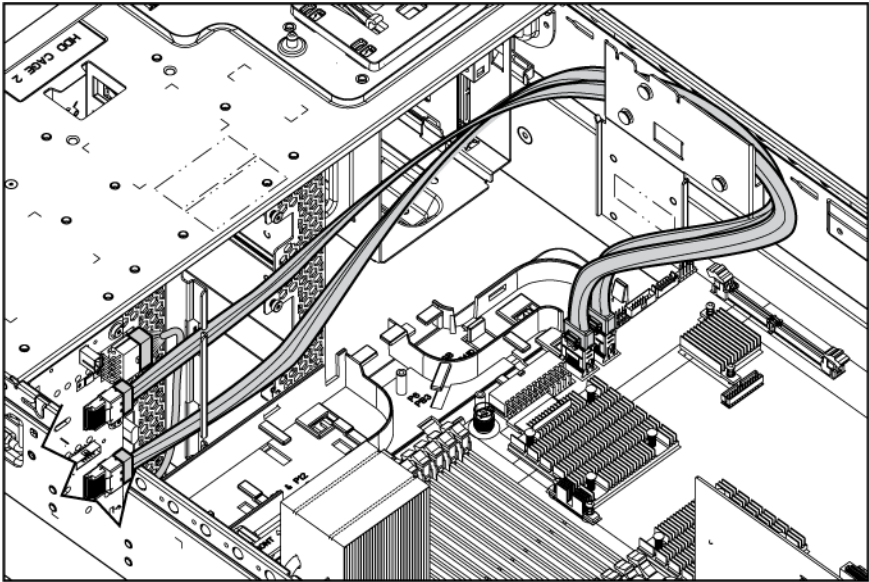

- Drive cage bay 2

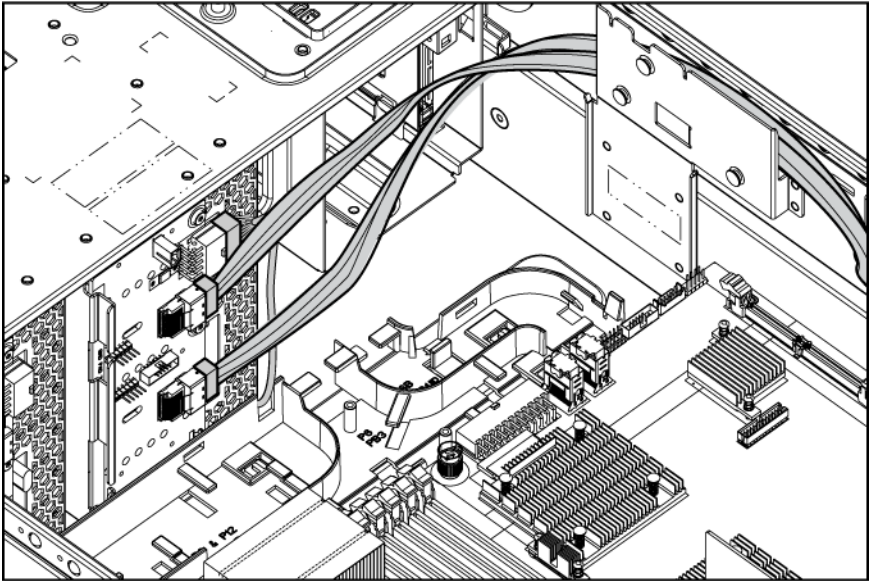

Two-bay LFF drive cage cabling

- Two-bay LFF drive cage cabling to an optional six-bay LFF backplane

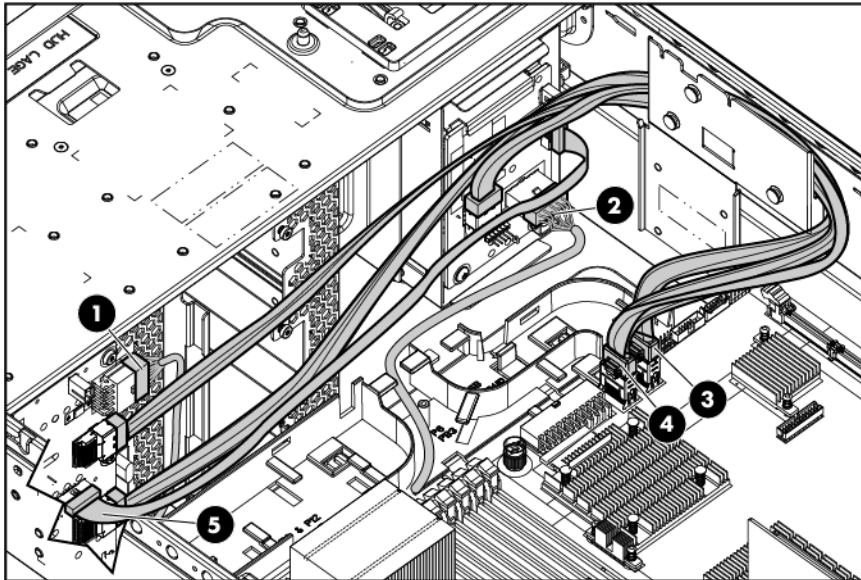

Item	Description
1	Drive cage bay 1 power cable
2	Drive cage bay 3 power cable
3	SAS cable (connector A)
4	SAS cable (connector B)
5	LED cable

- Two-bay LFF drive cage cabling to an optional SAS controller

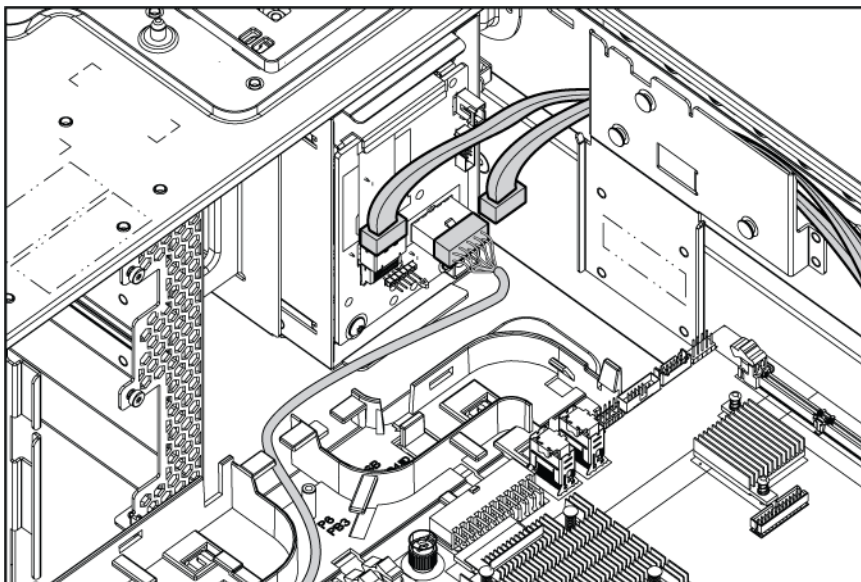

BBWC battery pack and FBWC capacitor pack cabling

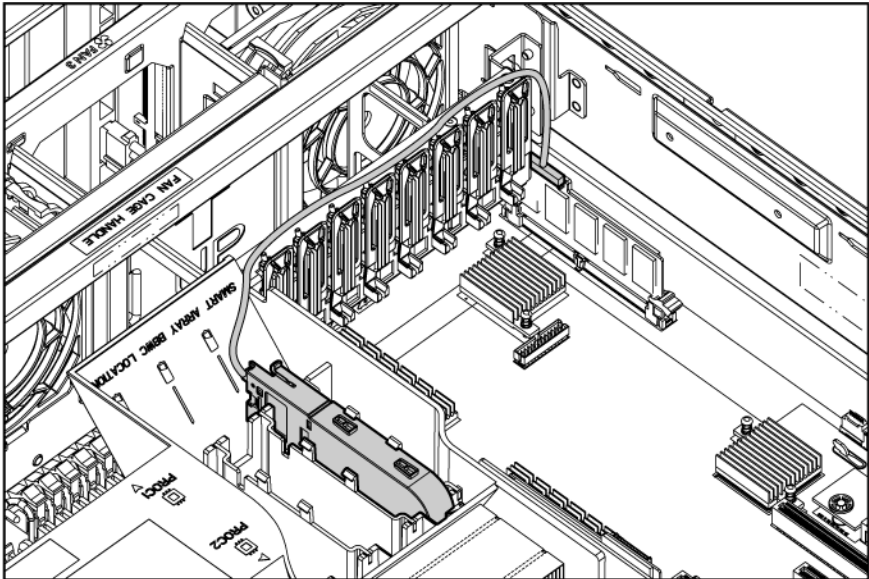

DVD-ROM drive cabling

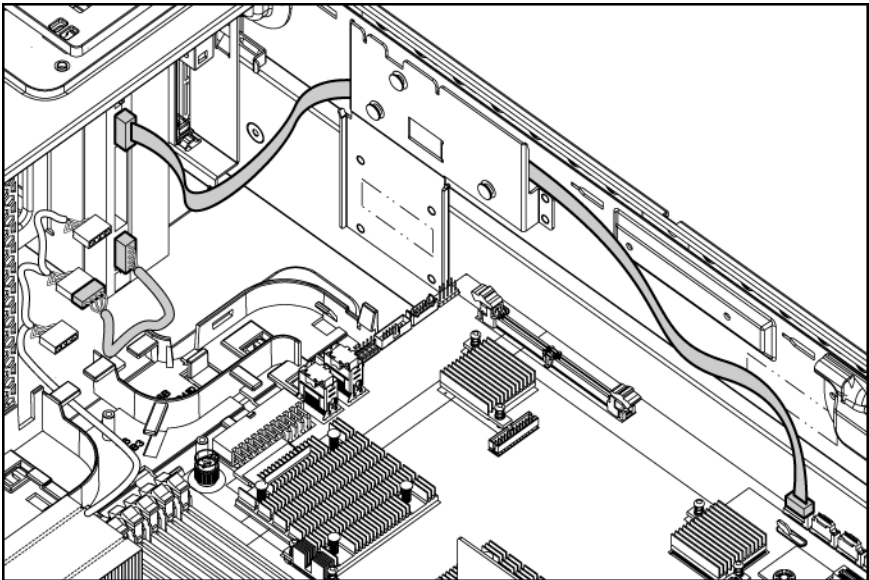

Slimline optical drive cabling

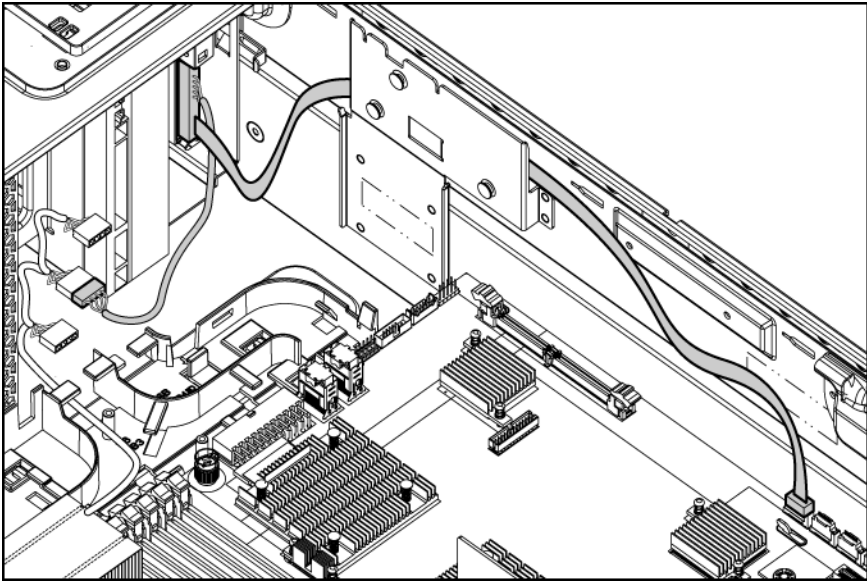

Diagnostic tools

Troubleshooting resources

The *HP ProLiant Servers Troubleshooting Guide* provides procedures for resolving common problems and comprehensive courses of action for fault isolation and identification, error message interpretation, issue resolution, and software maintenance on ProLiant servers and server blades. This guide includes problem-specific flowcharts to help you navigate complex troubleshooting processes. To view the guide, select a language:

- English (http://www.hp.com/support/ProLiant_TSG_en)
- French (http://www.hp.com/support/ProLiant_TSG_fr)
- Italian (http://www.hp.com/support/ProLiant_TSG_it)
- Spanish (http://www.hp.com/support/ProLiant_TSG_sp)
- German (http://www.hp.com/support/ProLiant_TSG_gr)
- Dutch (http://www.hp.com/support/ProLiant_TSG_nl)
- Japanese (http://www.hp.com/support/ProLiant_TSG_jp)

HP Insight Diagnostics

HP Insight Diagnostics is a proactive server management tool, available in both offline and online versions, that provides diagnostics and troubleshooting capabilities to assist IT administrators who verify server installations, troubleshoot problems, and perform repair validation.

HP Insight Diagnostics Offline Edition performs various in-depth system and component testing while the OS is not running. To run this utility, launch the SmartStart CD.

HP Insight Diagnostics Online Edition is a web-based application that captures system configuration and other related data needed for effective server management. Available in Microsoft® Windows® and Linux versions, the utility helps to ensure proper system operation.

For more information or to download the utility, refer to the HP website (<http://www.hp.com/servers/diags>).

HP Insight Diagnostics survey functionality

HP Insight Diagnostics (on page 85) provides survey functionality that gathers critical hardware and software information on ProLiant servers.

This functionality supports operating systems that may not be supported by the server. For operating systems supported by the server, see the HP website (<http://www.hp.com/go/supportos>).

If a significant change occurs between data-gathering intervals, the survey function marks the previous information and overwrites the survey data files to reflect the latest changes in the configuration.

Survey functionality is installed with every SmartStart-assisted HP Insight Diagnostics installation, or it can be installed through the HP PSP.

NOTE: The current version of SmartStart provides the memory spare part numbers for the server. To download the latest version, see the HP website (<http://www.hp.com/support>).

Integrated Management Log

The IML records hundreds of events and stores them in an easy-to-view form. The IML timestamps each event with 1-minute granularity.

You can view recorded events in the IML in several ways, including the following:

- From within HP SIM
- From within Survey Utility
- From within operating system-specific IML viewers
 - For NetWare: IML Viewer
 - For Windows®: IML Viewer
 - For Linux: IML Viewer Application
- From within the iLO 2 user interface
- From within HP Insight Diagnostics (on page 85)

For more information, see the Management CD in the HP Insight Foundation suite for ProLiant.

HP Insight Remote Support software

HP strongly recommends that you install HP Insight Remote Support software to complete the installation or upgrade of your product and to enable enhanced delivery of your HP Warranty, HP Care Pack Service, or HP contractual support agreement. HP Insight Remote Support supplements your monitoring 24 x 7 to ensure maximum system availability by providing intelligent event diagnosis, and automatic, secure submission of hardware event notifications to HP, which will initiate a fast and accurate resolution, based on your product's service level. Notifications may be sent to your authorized HP Channel Partner for on-site service, if configured and available in your country. The software is available in two variants:

- **HP Insight Remote Support Standard:** This software supports server and storage devices and is optimized for environments with 1–50 servers. Ideal for customers who can benefit from proactive notification but do not need proactive service delivery and integration with a management platform.
- **HP Insight Remote Support Advanced:** This software provides comprehensive remote monitoring and proactive service support for nearly all HP servers, storage, network, and SAN environments, plus selected non-HP servers that have a support obligation with HP. It is integrated with HP Systems Insight Manager. A dedicated server is recommended to host both HP Systems Insight Manager and HP Insight Remote Support Advanced.

Details for both versions are available on the HP website (<http://www.hp.com/go/insightremotesupport>).

To download the software, go to Software Depot (<http://www.software.hp.com>).

Select **Insight Remote Support** from the menu on the right.

USB support

HP provides both standard USB 2.0 support and legacy USB 2.0 support. Standard support is provided by the OS through the appropriate USB device drivers. Before the OS loads, HP provides support for USB devices through legacy USB support, which is enabled by default in the system ROM.

Legacy USB support provides USB functionality in environments where USB support is not available normally. Specifically, HP provides legacy USB functionality for the following:

- POST
- RBSU
- Diagnostics
- DOS
- Operating environments which do not provide native USB support

Component identification

Front panel components

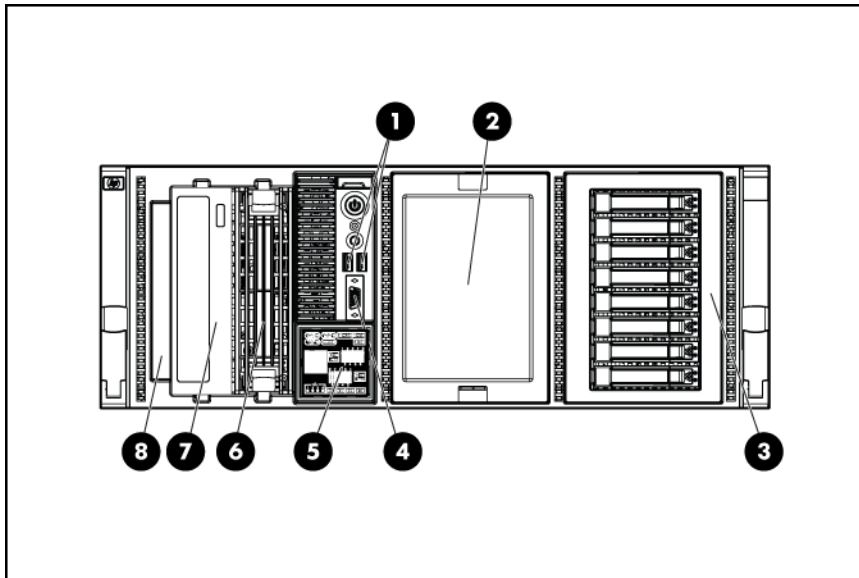

Item	Description
1	USB connectors (2)
2	Drive cage blank
3	SAS/SATA drives (8)
4	Front video connector (rack model only)
5	Systems Insight Display
6	Removable media bay
7	DVD-ROM drive
8	Optical drive blank

Front panel LEDs and buttons

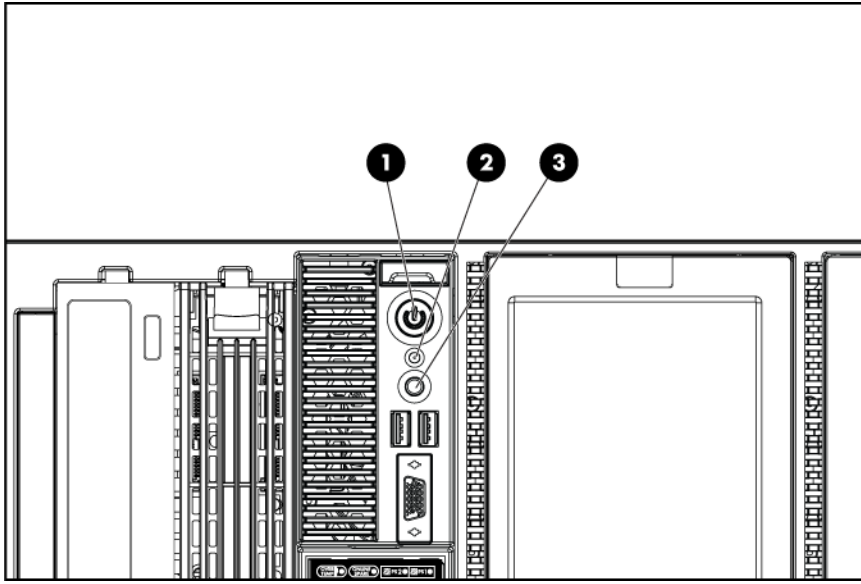

Item	Description	Status
1	Power On/Standby button and system power LED	Green = Normal (system on) Amber = System in standby, but power still applied Off = Power cord not attached or power supply failure
2	Health LED	Green = Normal (system on) Amber = System health is degraded Red = System health is critical. Off = Normal (system off)
3	UID LED	Blue = Activated Flashing blue = System is being managed remotely Off = Deactivated

Systems Insight Display LEDs

The HP Systems Insight Display LEDs represent the system board layout.

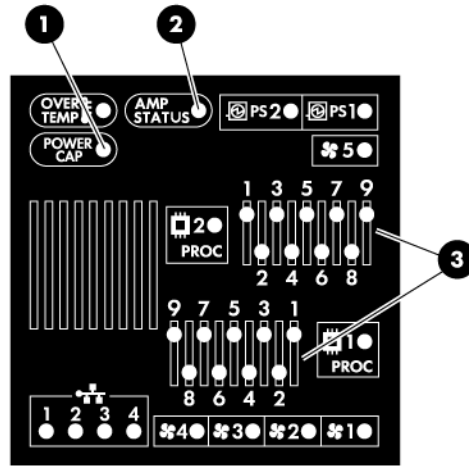

Item	Description	Status
1	Power cap	To determine Power cap status, see "Systems Insight Display LED combinations (on page 90)."
2	AMP Status	Green = AMP mode enabled Amber = Failover Flashing amber = Invalid configuration Off = AMP mode disabled
3	DIMM LEDs	All LEDs flashing = DIMM unseated
	All other LEDs	Amber = Failure Off = Normal



IMPORTANT: If more than one DIMM slot LED is illuminated, further troubleshooting is required. Test each bank of DIMMs by removing all other DIMMs. Isolate the failed DIMM by replacing each DIMM in a bank with a known working DIMM.

Systems Insight Display LED combinations

When the health LED on the front panel illuminates either amber or red, the server is experiencing a health event. Combinations of illuminated Systems Insight Display LEDs, the system power LED, and the health LED indicate system status.

Systems Insight Display LED and color	Health LED	System power LED	Status
Processor (amber)	Red	Amber	One or more of the following conditions may exist: <ul style="list-style-type: none"> • Processor in socket X has failed. • Processor X is not installed in the socket. • Processor X is unsupported. • ROM detects a failed processor during POST
Processor (amber)	Amber	Green	Processor in socket X is in a pre-failure condition.
DIMM (amber)	Red	Green	One or more DIMMs have failed.
DIMM (amber)	Amber	Green	DIMM in slot X is in a pre-failure condition.
Overtemperature (amber)	Amber	Green	The Health Driver has detected a cautionary temperature level.
Overtemperature (amber)	Red	Amber	The server has detected a hardware critical temperature level.
Fan (amber)	Amber	Green	One fan has failed or has been removed.
Fan (amber)	Red	Green	Two or more fans have failed or been removed.
Power supply (amber)	Red	Amber	<ul style="list-style-type: none"> • Only one power supply is installed and that power supply is in standby. • Power supply fault • System board fault
Power supply (amber)	Amber	Green	<ul style="list-style-type: none"> • Redundant power supply is installed and only one power supply is functional. • AC power cord is not plugged into redundant power supply. • Redundant power supply fault • Power supply mismatch at POST or power supply mismatch through hot-plug addition.
Power cap (off)	—	Amber	Standby
Power cap (green)	—	Flashing green	Waiting for power
Power cap (flashing amber)	—	Amber	Power cap has been exceeded
Power cap (green)	—	Green	Power is available



IMPORTANT: If more than one DIMM slot LED is illuminated, further troubleshooting is required. Test each bank of DIMMs by removing all other DIMMs. Isolate the failed DIMM by replacing each DIMM in a bank with a known working DIMM.

Rear panel components

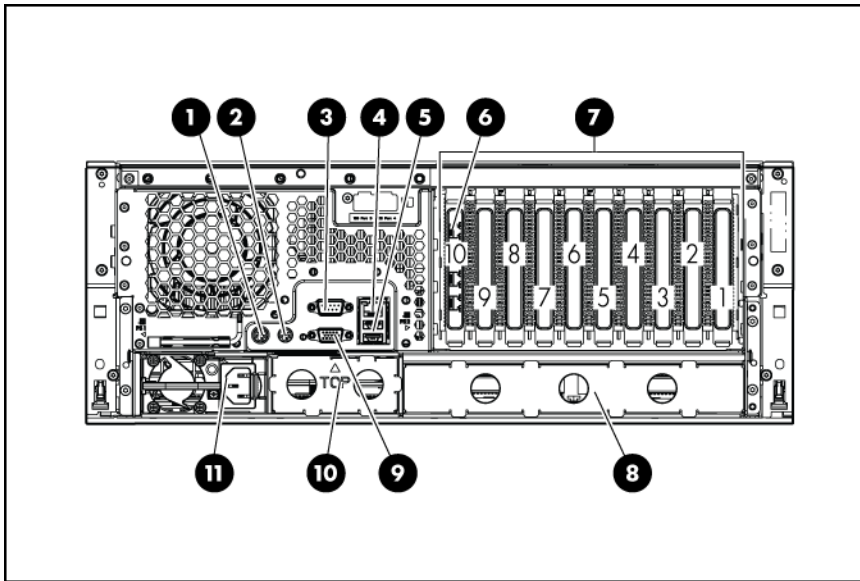

Item	Description
1	Mouse connector
2	Keyboard connector
3	Serial connector
4	iLO 2 connector
5	USB connectors (2)
6	NIC connectors (4)
7	PCI expansion slots
8	Reserved for PCI-X option kit
9	Video connector
10	Power supply bay 2
11	Power supply bay 1 (populated)

Rear panel LEDs

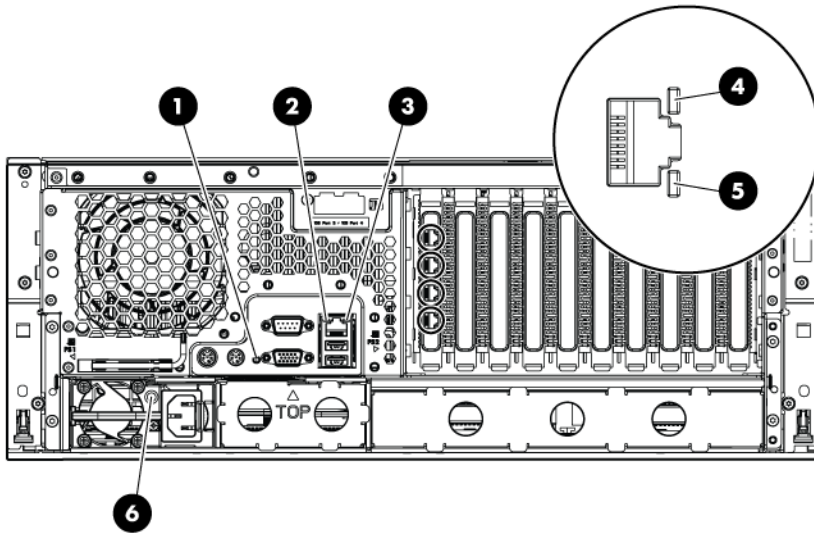

Item	Description	Status
1	UID LED	Blue = Activated Flashing blue = System is being managed remotely. Off = Deactivated
2	iLO 2 activity LED	Green or flashing green = Network activity Off = No network activity
3	iLO 2 link LED	Green = Linked to network Off = No network connection
4	NIC link LED	Green = Linked to network Off = No network connection
5	NIC activity LED	Green or flashing green = Network activity Off = No network activity
6	Power supply LED	Green = System has AC power and is powered up. Off = System has no AC power, the system is off, or the power supply has failed.

System board components

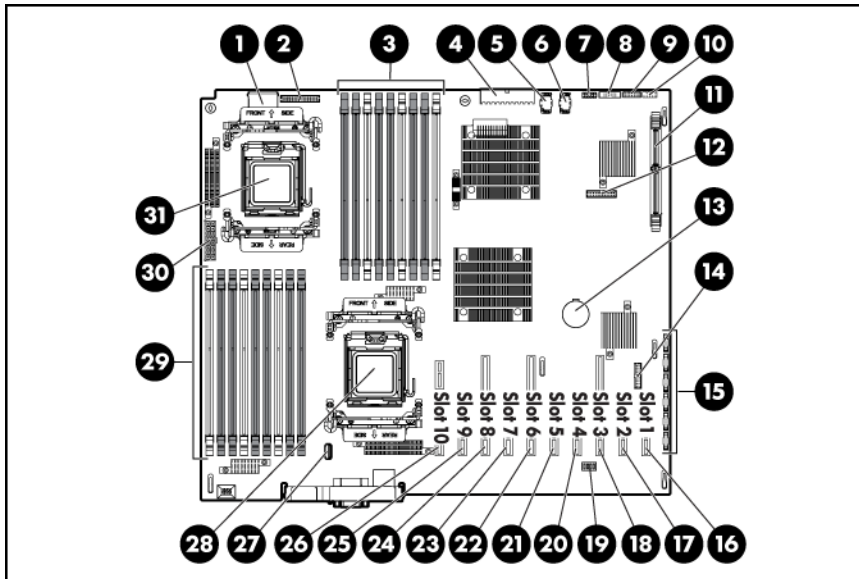

Item	Description
1	SD card slot
2	Power backplane connector
3	Processor 1 DIMM slots
4	Power supply connector
5	SAS connector B
6	SAS connector A
7	Front panel connector
8	Systems Insight Display connector
9	Front video connector
10	Front USB connector
11	Smart Array P410i memory module
12	Reserved
13	System battery
14	TPM connector
15	SATA connectors (6)
16	Slot 1 PCIe x8 (4, 2, 1)
17	Slot 2 PCIe2 x8 (4, 2, 1)
18	Slot 3 PCIe2 x16 (16, 8, 4, 2, 1)
19	System maintenance switch
20	Slot 4 PCIe2 x8 (4, 2, 1)
21	Slot 5 PCIe2 x8 (4, 2, 1)
22	Slot 6 PCIe2 x16 (8, 4, 2, 1)
23	Slot 7 PCIe2 x8 (4, 2, 1)

Item	Description
24	Slot 8 PCIe2 x16 (16, 8, 4, 2, 1)
25	Slot 9 PCIe2 x8 (4, 2, 1)
26	Slot 10 PCIe2 x8 (8, 4, 2, 1)
27	Internal USB connector
28	Processor socket 2
29	Processor 2 DIMM slots
30	Power supply connector
31	Processor socket 1 (populated)

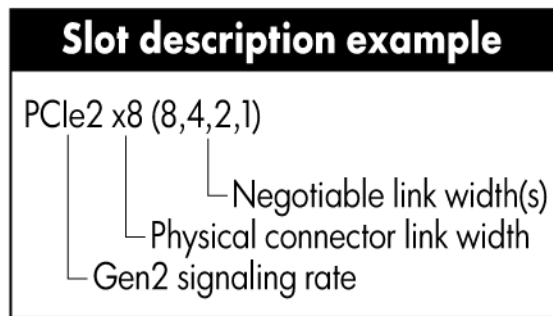

DIMM slots

DIMM slots are numbered sequentially (1 through 9) for each processor. The supported AMP modes use the letter assignments for population guidelines.

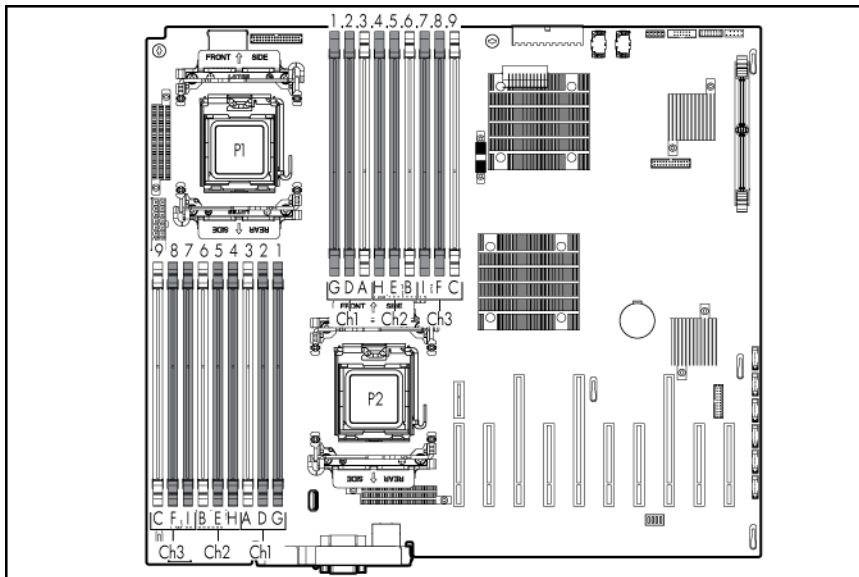

DIMM identification



IMPORTANT: This server does not support mixing RDIMMs and UDIMMs. Attempting to mix these two types causes the server to halt during BIOS initialization.

The memory subsystem may be populated with either RDIMMs or UDIMMs, but mixing the two types is not supported. To determine DIMM characteristics, use the label attached to the DIMM and the following illustration and table.

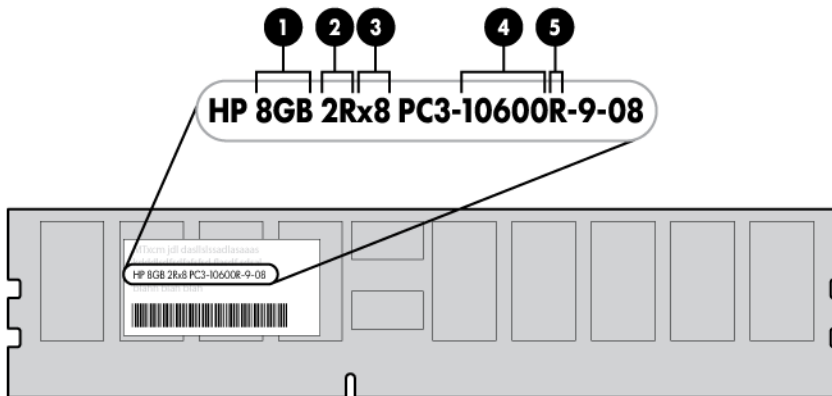

Item	Description	Definition
1	Size	—
2	Rank	1R = Single-rank 2R = Dual-rank 4R = Quad-rank
3	Data width	x4 = 4-bit x8 = 8-bit
4	Memory speed	10600 = 1333-MHz 8500 = 1066-MHz
5	DIMM type	R = RDIMM (registered) E = UDIMM (unbuffered with ECC)

For the latest supported memory information, see the QuickSpecs on the HP website (<http://www.hp.com>).

System maintenance switch

The system maintenance switch (SW1) is a ten-position switch that is used for system configuration.

Position	Description	Function
S1	iLO security	Off = iLO security is enabled. On = iLO security is disabled.
S2	Configuration lock	Off = System configuration can be changed. On = System configuration is locked.

Position	Description	Function
S3	Rack/Tower ID	Off = Tower On = Rack
S4	Reserved	Reserved
S5	Password protection override	Off = No function On = Clears power-on password and administrator password
S6	Invalidate configuration	Off = Normal On = ROM treats the system configuration as invalid.
S7	Reserved	Reserved
S8	Reserved	Reserved
S9	Reserved	Reserved
S10	Reserved	Reserved

When the system maintenance switch position 6 is set to the On position, the system is prepared to erase all system configuration settings from both CMOS and NVRAM.

 **CAUTION:** Clearing CMOS and/or NVRAM deletes configuration information. Be sure to properly configure the server or data loss could occur.

NMI functionality

An NMI crash dump enables administrators to create crash dump files when a system is hung and not responding to traditional debug mechanisms.

Crash dump log analysis is an essential part of diagnosing reliability problems, such as hangs in operating systems, device drivers, and applications. Many crashes freeze a system, and the only available action for administrators is to cycle the system power. Resetting the system erases any information that could support problem analysis, but the NMI feature preserves that information by performing a memory dump before a hard reset.

To force the OS to invoke the NMI handler and generate a crash dump log, the administrator can do any of the following:

- Short the NMI jumper pins
- Press the NMI switch
- Use the iLO Virtual NMI feature

For additional information, see the whitepaper on the HP website

(<http://h20000.www2.hp.com/bc/docs/support/SupportManual/c00797875/c00797875.pdf>).

SAS and SATA device numbers

With optional hard drive cages installed, the server supports up to 24 SFF hard drives or up to 14 LFF hard drives. The server does not support mixing SFF and LFF hard drives.

HP recommends populating hard drive bays starting with the lowest SAS or SATA device number.

- SFF hard drives

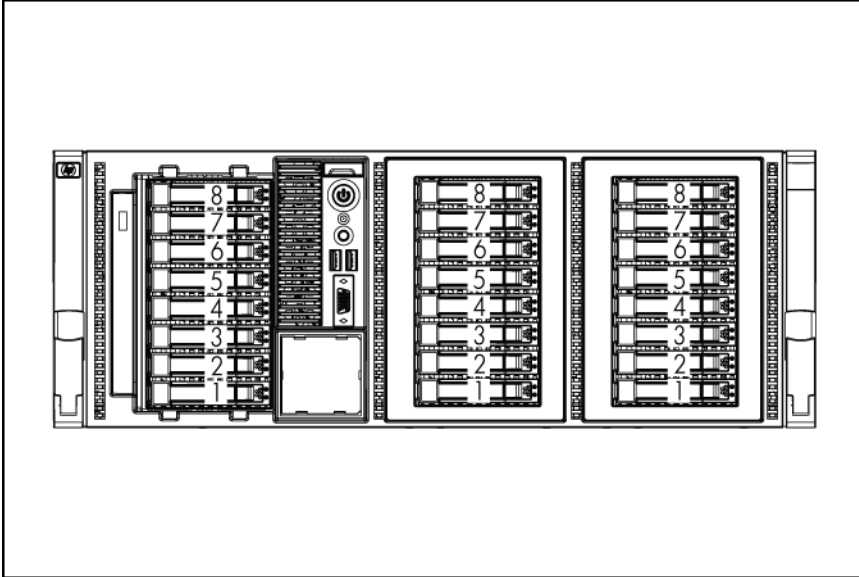

- LFF hard drives

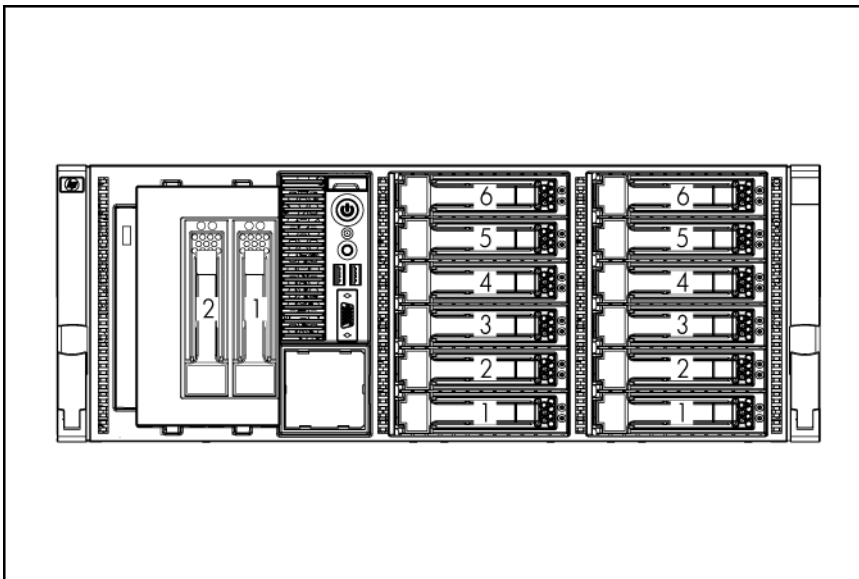

SAS and SATA hard drive LEDs

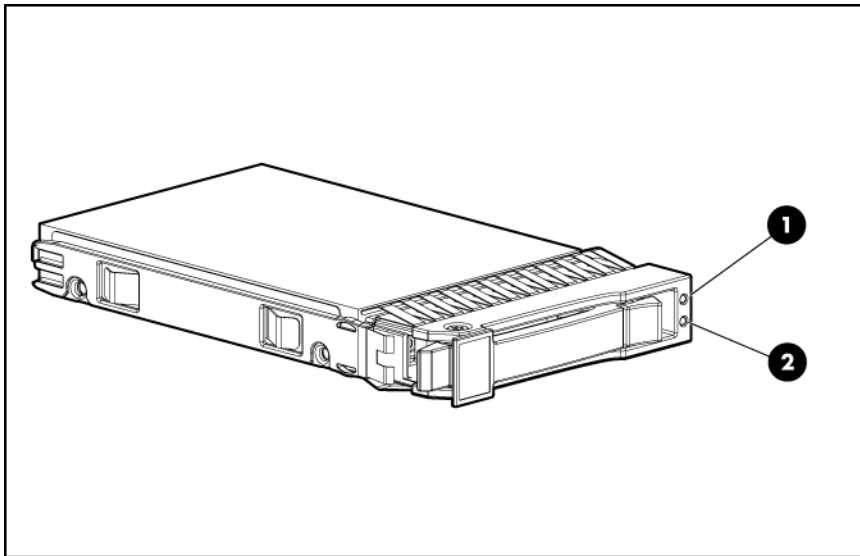

Item	Description	Status
1	Fault/UID LED	Amber = Drive failure Flashing amber = Fault-process activity Blue = Unit identification is active Off = No fault-process activity
2	Online/activity LED	Green = Drive activity Flashing green = High activity on the drive or drive is being configured as part of an array Off = No drive activity

SAS and SATA hard drive LED combinations

Online/activity LED (green)	Fault/UID LED (amber/blue)	Interpretation
On, off, or flashing	Alternating amber and blue	The drive has failed, or a predictive failure alert has been received for this drive; it also has been selected by a management application.
On, off, or flashing	Steadily blue	The drive is operating normally, and it has been selected by a management application.
On	Amber, flashing regularly (1 Hz)	A predictive failure alert has been received for this drive. Replace the drive as soon as possible.
On	Off	The drive is online, but it is not active currently.

Online/activity LED (green)	Fault/UID LED (amber/blue)	Interpretation
Flashing regularly (1 Hz)	Amber, flashing regularly (1 Hz)	Do not remove the drive. Removing a drive may terminate the current operation and cause data loss. The drive is part of an array that is undergoing capacity expansion or stripe migration, but a predictive failure alert has been received for this drive. To minimize the risk of data loss, do not replace the drive until the expansion or migration is complete.
Flashing regularly (1 Hz)	Off	Do not remove the drive. Removing a drive may terminate the current operation and cause data loss. The drive is rebuilding, or it is part of an array that is undergoing capacity expansion or stripe migration.
Flashing irregularly	Amber, flashing regularly (1 Hz)	The drive is active, but a predictive failure alert has been received for this drive. Replace the drive as soon as possible.
Flashing irregularly	Off	The drive is active, and it is operating normally.
Off	Steadily amber	A critical fault condition has been identified for this drive, and the controller has placed it offline. Replace the drive as soon as possible.
Off	Amber, flashing regularly (1 Hz)	A predictive failure alert has been received for this drive. Replace the drive as soon as possible.
Off	Off	The drive is offline, a spare, or not configured as part of an array.

Fans

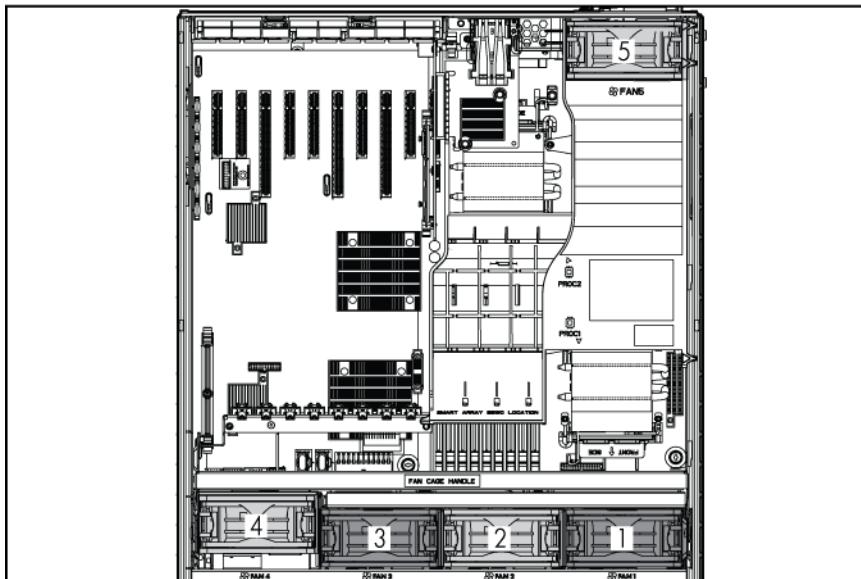

Item	Description	Configuration
1	Fan 1	Redundant
2	Fan 2	Primary
3	Fan 3	Redundant

Item	Description	Configuration
4	Fan 4	Primary
5	Fan 5	Primary

Battery pack LEDs

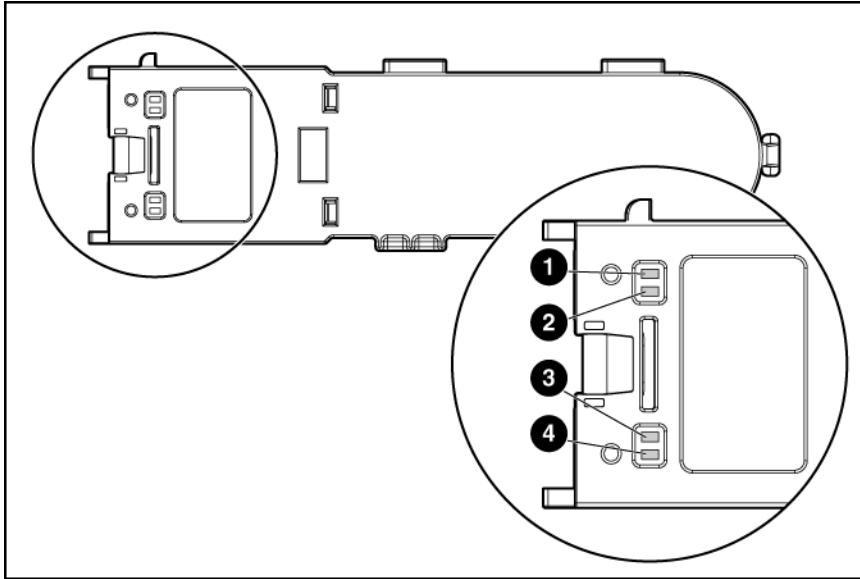

Item ID	Color	Description
1	Green	System Power LED. This LED glows steadily when the system is powered up and 12 V system power is available. This power supply is used to maintain the battery charge and provide supplementary power to the cache microcontroller.
2	Green	Auxiliary Power LED. This LED glows steadily when 3.3V auxiliary voltage is detected. The auxiliary voltage is used to preserve BBWC data and is available any time that the system power cords are connected to a power supply.
3	Amber	Battery Health LED. To interpret the illumination patterns of this LED, see the following table.
4	Green	BBWC Status LED. To interpret the illumination patterns of this LED, see the following table.

LED3 pattern	LED4 pattern	Interpretation
—	One blink every two seconds	The system is powered down, and the cache contains data that has not yet been written to the drives. Restore system power as soon as possible to prevent data loss. Data preservation time is extended any time that 3.3 V auxiliary power is available, as indicated by LED 2. In the absence of auxiliary power, battery power alone preserves the data. A fully-charged battery can normally preserve data for at least two days. The battery lifetime also depends on the cache module size. For further information, refer to the controller QuickSpecs on the HP website (http://www.hp.com).
—	Double blink, then pause	The cache microcontroller is waiting for the host controller to communicate.
—	One blink per second	The battery pack is below the minimum charge level and is being charged. Features that require a battery (such as write cache, capacity expansion, stripe size migration, and RAID migration) are temporarily unavailable until charging is complete. The recharge process takes between 15 minutes and two hours, depending on the initial capacity of the battery.
—	Steady glow	The battery pack is fully charged, and posted write data is stored in the cache.
—	Off	The battery pack is fully charged, and there is no posted write data in the cache.
One blink per second	One blink per second	An alternating green and amber blink pattern indicates that the cache microcontroller is executing from within its boot loader and receiving new flash code from the host controller.
Steady glow	—	There is a short circuit across the battery terminals or within the battery pack. BBWC features are disabled until the battery pack is replaced. The life expectancy of a battery pack is typically more than three years.
One blink per second	—	There is an open circuit across the battery terminals or within the battery pack. BBWC features are disabled until the battery pack is replaced. The life expectancy of a battery pack is typically more than three years.

FBWC module LEDs

The FBWC module has two single-color LEDs (green and amber). The LEDs are duplicated on the reverse side of the cache module to facilitate status viewing.

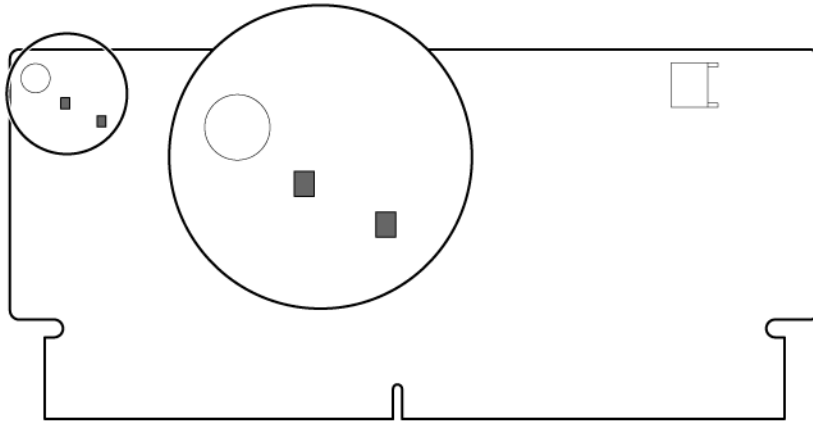

Green LED	Amber LED	Interpretation
Off	On	A backup is in progress.
Flashing (1 Hz)	On	A restore is in progress.
Flashing (1 Hz)	Off	The capacitor pack is charging.
On	Off	The capacitor pack has completed charging.
Flashing (2 Hz) Alternating with amber LED	Flashing (2 Hz) Alternating with green LED	One of the following conditions exists: <ul style="list-style-type: none"> The charging process has timed out. The capacitor pack is not connected.
On	On	The flash code image failed to load.
Off	Off	The flash code is corrupt.

Power supply backplane connectors

Connector	Description
BP1	Drive bay 1 power cable
BP2	Drive bay 2 power cable
BP3	Drive bay 3 power cable
P1	Power supply 1 cable
P2	Power supply 2 cable
P6	SATA power cable
P7	SATA power cable
P8	SATA power cable
P9	Video adapter power cable
P10	Data cable
P12	Video adapter power cable

Drive cage jumper location and configuration settings

- Two-bay LFF backplane

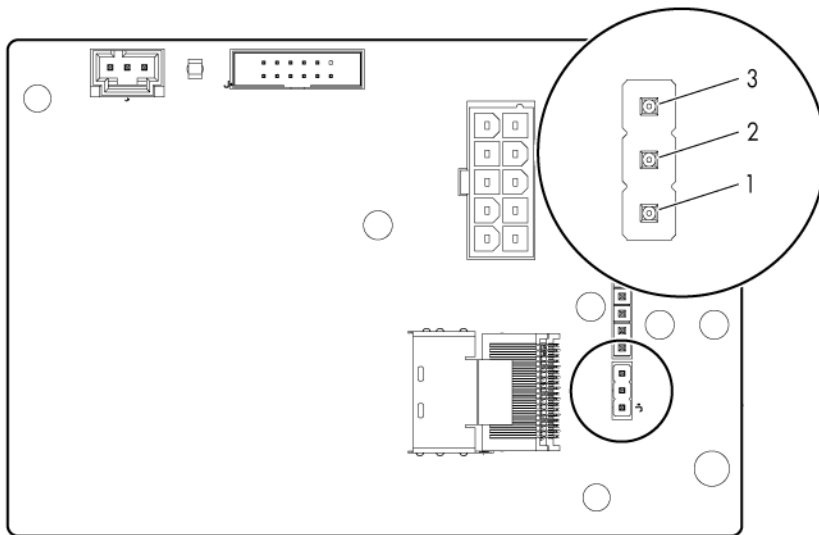

- Six-bay LFF backplane

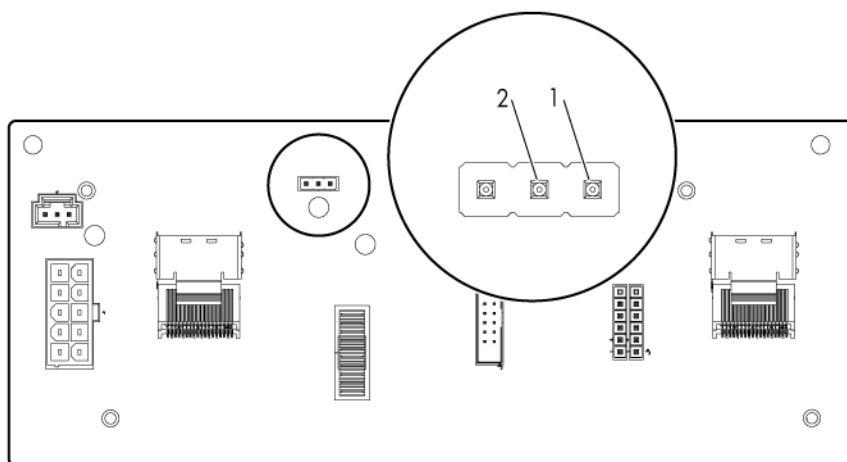

- Eight-bay SFF backplane

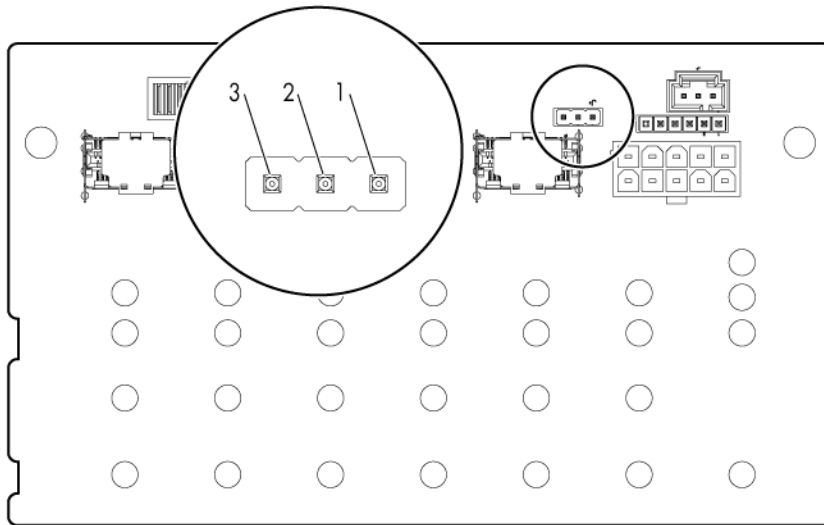

Drive cage	Installation	Pin setting
1	Standard	No jumper
2	Optional	1-2*
3	Optional	2-3

*Optional drive cages ship with the jumper set across pins 1 and 2.

Specifications

Environmental specifications

Specification	Value
Temperature range*	
Operating	10°C to 35°C (50°F to 95°F)
Shipping	-40°C to 70°C (-40°F to 158°F)
Maximum wet bulb temperature	28°C (82.4°F)
Relative humidity (noncondensing)**	
Operating	10% to 90%
Non-operating	5% to 95%

* All temperature ratings shown are for sea level. An altitude derating of 1°C per 300 m (1.8°F per 1,000 ft) to 3048 m (10,000 ft) is applicable. No direct sunlight allowed.

** Storage maximum humidity of 95% is based on a maximum temperature of 45°C (113°F). Altitude maximum for storage corresponds to a pressure minimum of 70 kPa.

Server specifications

Specification	Value
Dimensions	
Rack model	—
Height	17.48 cm (6.88 in)
Depth	69.93 cm (27.53 in)
Width	48.34 cm (19.03 in)
Tower model	—
Height	47.04 cm (18.52 in)
Depth	73.96 cm (29.12 in)
Width	24.77 cm (9.75 in)
Weight	
Weight (when lightly loaded)	—
Rack	25.00 kg (55.12 lbs)
Tower	30.00 kg (66.14 lbs)
Weight (maximum)	46.75 kg (103.06 lbs)

Power supply specifications

Depending on installed options, the server is configured with one of the following power supplies:

- HP ProLiant 1200 W Power Supply

Specification	Value
Input requirements	
Rated input voltage	100 to 120 VAC, 200 to 240 VAC
Rated input frequency	50 Hz to 60 Hz
Rated input current	10 A at 100 VAC 4.9 A at 200 VAC
Rated input power	930 W at 100V AC input 1348 W at 200V AC input
BTUs per hour	3530 at 120V AC input 4600 at 200V to 240V AC input
Power supply output	
Rated steady-state power	800 W at 100V AC input 900 W at 120V AC input 1200 W at 200V to 240V AC input
Maximum peak power	800 W at 100V AC input 900 W at 120V AC input 1200 W at 200V to 240V AC input

- HP ProLiant 750 W Power Supply

Specification	Value
Input requirements	
Rated input voltage	100 to 120 VAC, 200 to 240 VAC
Rated input frequency	50 Hz to 60 Hz
Rated input current	8.9 A at 100 VAC 4.3 A at 200 VAC
Rated input power	857 W at 100V AC input 824 W at 200V AC input
BTUs per hour	2925 at 100V AC input 2812 at 200V AC input
Power supply output	
Rated steady-state power	750 W at 100V to 120V AC input 750 W at 200V to 240V AC input

Maximum peak power	750 W at 100V to 120V AC input 750 W at 200V to 240V AC input
--------------------	--

- HP ProLiant 460 W Power Supply

Specification	Value
Input requirements	
Rated input voltage	100 to 120 VAC, 200 to 240 VAC
Rated input frequency	50 Hz to 60 Hz
Rated input current	5.5 A at 100 VAC 2.6 A at 200 VAC
Rated input power	526 W at 100V AC input 505 W at 200V AC input
BTUs per hour	1794 at 100V AC input 1725 at 200V AC input
Power supply output	
Rated steady-state power	460 W at 100V to 120V AC input 460 W at 200V to 240V AC input
Maximum peak power	460 W at 100V to 120V AC input 460 W at 200V to 240V AC input

Acronyms and abbreviations

AMP

Advanced Memory Protection

BBWC

battery-backed write cache

CMOS

complementary metal-oxide semiconductor

CSR

Customer Self Repair

FBWC

flash-backed write cache

iLO

Integrated Lights-Out

IML

Integrated Management Log

LFF

large form-factor

NCQ

Native Command Queuing

NMI

non-maskable interrupt

NVRAM

non-volatile memory

ORCA

Option ROM Configuration for Arrays

PCIe

peripheral component interconnect express

POST

Power-On Self Test

PSP

ProLiant Support Pack

RBSU

ROM-Based Setup Utility

RDIMM

Registered Dual In-line Memory Module

SAS

serial attached SCSI

SATA

serial ATA

SFF

small form-factor

SIM

Systems Insight Manager

TPM

trusted platform module

UDIMM

Unregistered Dual In-Line Memory Module

UID

unit identification

Index

A

access panel 33
additional information 85
air baffle 29, 36

B

battery 94, 97
battery cabling for BBWC 83
battery pack LEDs 101
battery pack, removing 35
battery-backed write cache (BBWC) 34, 35, 101
BBWC (battery-backed write cache) 34, 35, 101
BBWC battery pack 35
blue screen event 97
buttons 88

C

cable management arm 31
cables 68, 69, 79
cabling 79, 81, 82, 83, 84
cabling, storage system 79
cache module 34
capacitor pack 35, 103
components 17, 21, 27, 71, 88
components, identification 88, 97
connectors 88
crash dump analysis 97
CSR (customer self repair) 6
customer self repair (CSR) 6

D

device numbers 98
diagnostic tools 85
diagnostics utility 85
DIMM identification 95
DIMM slots 94, 95
DIMMs 95
drive cage jumper 104
drive LEDs 99
DVD-ROM cabling 83
DVD-ROM drive 44, 88

E

Eight-bay SFF drive cage 79
Eight-bay SFF drive cage backplane 50, 51, 53
electrostatic discharge 27
environmental requirements 106
environmental specifications 106
expansion slots 92, 94
extending server from rack 30

F

fan 33, 39
fan blank 38
fan cage 37
fans 100
fans, removing 33, 39
FBWC cabling 83
FBWC capacitor pack 35, 83
FBWC module 34, 103
FBWC module LEDs 103
features 88
front panel buttons 89
front panel components 88
front panel connector 94
front panel LEDs 89

H

hard drive backplane 47
hard drive blanks 43
hard drive cage 47
hard drive cage blank 46
hard drive LEDs 99
hard drives 43, 88, 99
hard drives, determining status of 99
hard drives, removing 43
health LEDs 89, 97
heatsink 55
hot-plug fans 31
HP Insight Diagnostics 85
HP Insight Diagnostics survey functionality 85
HP Insight Remote Support software 86
HP NC375i adapter 64
HP NC524SFP Dual Port 10GbE Module 66

I

I/O bezel 69
illustrated parts catalog 17
iLO 2 activity LED 93
iLO 2 link LED 93
IML (Integrated Management Log) 86
Insight Diagnostics 85
Integrated Management Log (IML) 86
internal USB connector 94

J

jumper settings 104

K

keyboard connector 92

L

LED, system power 29
LEDs 88, 89, 90, 93
LEDs, battery pack 101
LEDs, FBWC module 103
LEDs, hard drive 99
LEDs, SAS hard drive 99
LEDs, SATA hard drive 99
link LED 93

M

management tools 85
mechanical components 17
media bay 88
media bay blank 44
memory 62
memory dump 97
mouse connector 92

N

NIC activity LED 93
NIC connectors 92
NIC link LED 93
NMI functionality 97
NMI jumper 97
NMI switch 97

O

operating system crash 97
optical drive blank 88

P

part numbers 17
PCI expansion slots 92, 94
PCIe expansion boards 63
power backplane connector 94
power cap 90
power LEDs, system 101
Power On/Standby button 29, 89
power supply 54
power supply backplane 77
power supply backplane connector 103
power supply connector 94
power supply LEDs 93
powering down 29
preparation procedures 29
processors 57, 94

R

rack warnings 28
rear panel components 92
rear panel LEDs 93
rear panel, accessing 31
removal and replacement procedures 27
removing server from rack 29
removing the access panel 33
replacement procedures 27
requirements, environmental 106
resetting the system 97

S

safety considerations 27
SAS connector 94
SAS device numbers 98
SAS drive numbers 99
SAS drives 99
SAS hard drive 99
SAS hard drive LEDs 99
SATA connectors 94
SATA hard drive 99
SATA hard drive LEDs 99
SD card slot 94
serial connector 92
server specifications 106
side panels, removing 40
six-bay LFF backplane 49, 81
slimline optical drive 45, 84
Smart Array P410i controller 94
specifications 106, 107
specifications, environmental 106

- specifications, server 106
- static electricity 27
- status lights, battery pack 101
- storage system, cabling 79
- switch, NMI 97
- switches 97
- symbols on equipment 27
- system battery 70
- system board 71
- system board components 94
- system components 21, 88
- system maintenance switch 94, 96, 97
- system power LED 29, 89, 101
- Systems Insight Display 67, 68, 88, 90
- Systems Insight Display connector 94
- Systems Insight Display LEDs 90

T

- telco racks 29
- tools 27, 85
- Torx screwdriver 27
- tower bezel, removing 32
- tower feet 42
- TPM (Trusted Platform Module) 71, 94
- TPM connector 94
- troubleshooting 85
- troubleshooting resources 85
- two-bay LFF drive cage 82
- two-bay LFF drive cage backplane 47

U

- UID LED 89, 93, 97
- USB connectors 88, 92, 94
- USB support 87
- utilities 85

V

- video connector 88, 92, 94

W

- warranty 6