

Operating Instructions

Indoor Pan/Tilt Head
AW-PH360N

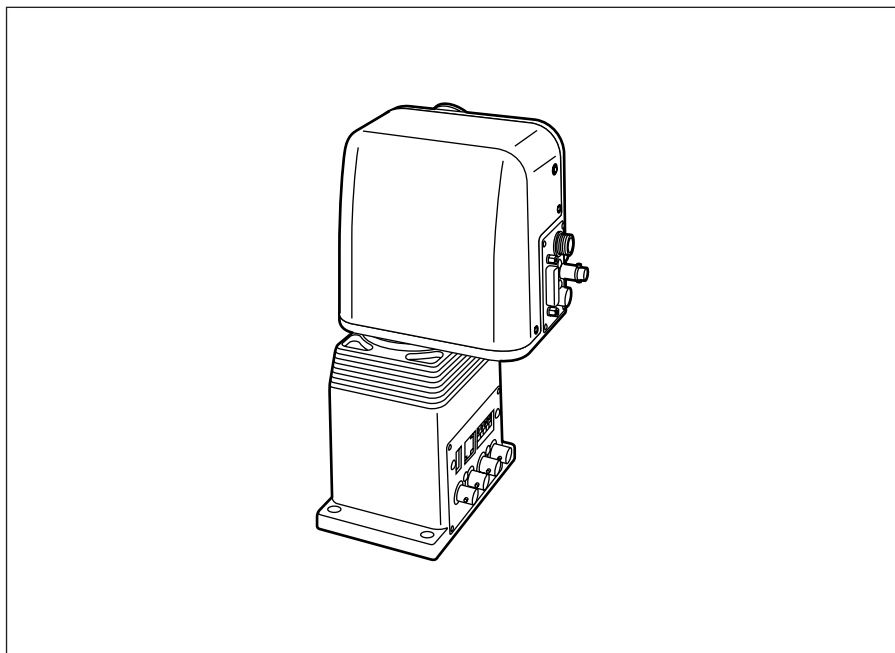

Panasonic®

Before attempting to connect, operate or adjust this product,
please read these instructions completely.



CAUTION
RISK OF ELECTRIC SHOCK
DO NOT OPEN



CAUTION: TO REDUCE THE RISK OF ELECTRIC SHOCK,
DO NOT REMOVE COVER (OR BACK).
NO USER SERVICEABLE PARTS INSIDE.
REFER TO SERVICING TO QUALIFIED SERVICE PERSONNEL.



The lightning flash with arrowhead symbol, within an equilateral triangle, is intended to alert the user to the presence of uninsulated “dangerous voltage” within the product’s enclosure that may be of sufficient magnitude to constitute a risk of electric shock to persons.



The exclamation point within an equilateral triangle is intended to alert the user to the presence of important operating and maintenance (service) instructions in the literature accompanying the appliance.

WARNING:

TO REDUCE THE RISK OF FIRE OR SHOCK HAZARD, DO NOT EXPOSE THIS EQUIPMENT TO RAIN OR MOISTURE.

WARNING:

**HAZARDOUS MOVING PARTS
KEEP FINGERS AND OTHER BODY PARTS AWAY.**

CAUTION:

TO REDUCE THE RISK OF FIRE OR SHOCK HAZARD AND ANNOYING INTERFERENCE, USE THE RECOMMENDED ACCESSORIES ONLY.

CAUTION:

TO REDUCE THE RISK OF FIRE OR SHOCK HAZARD, REFER CHANGE OF SWITCH SETTING INSIDE THE UNIT TO QUALIFIED SERVICE PERSONNEL.

 indicates safety information.

FCC Note:

This device complies with Part 15 of the FCC Rules. To assure continued compliance follow the attached installation instructions and do not make any unauthorized modifications.

This equipment has been tested and found to comply with the limits for a class A digital device, pursuant to Part 15 of the FCC Rules. These limits are designed to provide reasonable protection against harmful interference when the equipment is operated in a commercial environment. This equipment generates, uses, and can radiate radio frequency energy and, if not installed and used in accordance with the instruction manual, may cause harmful interference to radio communications. Operation of this equipment in a residential area is likely to cause harmful interference in which case the user will be required to correct the interference at his own expense.

Replace battery with part No. CR2032 only.
Use of another battery may present a risk of fire or explosion.
Caution—Battery may explode if mistreated.
Do not recharge, disassemble or dispose of in fire.

 indicates safety information.

Contents

Introduction	4	Connections	18
Accessories	4	■ Connecting the connector panel	18
Installation precautions	5	■ Head connector panel	23
Precautions for use	6	■ Connecting the base connector	
Parts and their functions	7	rear panel and the base	
Installation	9	connector front panel	24
■ Assembling the pan/tilt head	9	■ Connecting the AC adapter for use	
■ Controller selection switch / installation		with the pan/tilt head	26
direction switch /		■ Connection examples	27
landing characteristics settings .	10	Limiters	43
■ Transmission signal		■ Setting/releasing the limiters	44
selection setting	11	Replacement of consumable parts ...	47
■ Setting the cable compensation		Specifications	48
circuit of video signals	12		
■ Installing the pan/tilt head	13		
■ Mounting the camera	14		

Introduction

- This is a compact stand-alone type of pan/tilt head which is capable of rotating 95 degrees upward and downward and 300 degrees on the horizontal.
- This pan/tilt head can bear a total weight of up to 8.8 lb (4 kg) for the camera and lens combined.
- The pan/tilt head can be controlled using the controllers AW-RP301, AW-RP305, AW-RP501, AW-RP505, AW-RP605A, AW-RP400 or a personal computer.
- The positions and settings for shooting up to 50 points can be entered as data into the preset memory.

Accessories

Please check the following accessories have been provided.

Camera cable	(×1)	Chain attachment screws	
Tilting arm	(×1)	(with flat and spring washers)	
Tilting arm fixing screws		M4 × 8 mm	(×1)
M4 × 12 mm	(×4)	M4 × 6 mm	(×1)
Safety chain	(×1)	M2.6 × 6 mm	(×1)

Installation precautions

- Do not install the pan/tilt head on any of its sides.
- Avoid using the pan/tilt head in kitchens or other places where there is excessive steam and oil fumes.
- Make sure that the installation of the pan/tilt head has been completed before mounting the camera onto it.
- This pan/tilt head has a maximum load capacity of 8.8 lb (4 kg).
Do not use it for loads over 8.8 lb (4 kg).
- Do not use a lens that will cause the camera to be poorly balanced. Such a lens should not be used even if the load capacity is under 8.8 lb (4 kg).
- Do not install the pan/tilt head outdoors or in any place where the temperature is over 113°F (45°C) or below 14°F (−10°C).
Further, it should be used where the ambient humidity is less than 90%.
- Screws for mounting the pan/tilt head are not provided with the stand and must therefore be purchased separately.
They should be selected with due consideration given to the location where the pan/tilt head is to be mounted and its load capacity.
- To supply power to the pan/tilt head, use only the AC adapter (AW-PS300A) designed for use with this pan/tilt head. The pan/tilt head cannot be powered by batteries or any other source of power.
- When handling the pan/tilt head, be sure to hold it by the base.
Do not lift the pan/tilt head by the head or tilting arm.
Doing so may cause the unit to malfunction.
- Do not turn the head or tilting arm by hand.
Doing so may cause the unit to malfunction.
- Dropping the pan/tilt head or subjecting it to a strong shock may cause malfunctioning or an accident.
- Install the pan/tilt head so that a clearance of at least 3.3 ft. (1 m) is left around the monitor.
- When mounting a camera onto the pan/tilt head, take due care to prevent the camera from slipping out of position or dropping.
- Install the pan/tilt head and set the limiters so as to ensure that none of the components mounted on the pan/tilt head or cables will make contact with any other objects in the vicinity when the pan/tilt head rotates.

Precautions for use

- In order to protect the environment when the pan/tilt head is to be discarded at the end of its service life, ask a specialized contractor to dispose of it properly.
- This pan/tilt head uses a manganese dioxide-lithium battery (CR2032).
Be absolutely sure to remove this battery when disposing of the pan/tilt head or printed circuit boards.
Be sure to dispose of any batteries removed according to the applicable regulations of the country concerned.
Do not dispose of this type of battery as household garbage.
For details on how to remove the battery, refer to the section on replacing the battery in “Replacement of consumable parts” (page 47).

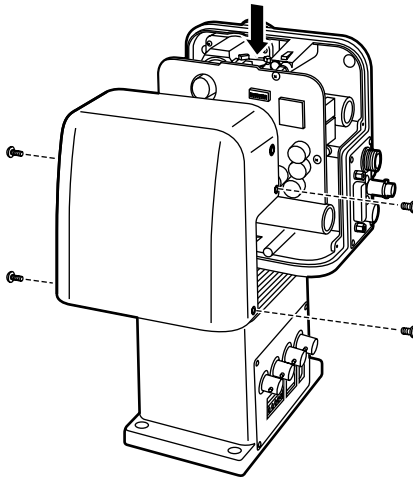

- To prevent malfunction because of contact with any objects in the vicinity when the pan/tilt head rotates, the unit is set to be shifted to the safe mode and the unit's tally lamp blinks if the overload to it happens.
In the safe mode, neither pan nor tilt operate.
To release the safe mode, turn off the power of the AC adapter connected to the pan/tilt head to dissolve the overload, then turn on the power again.

Parts and their functions

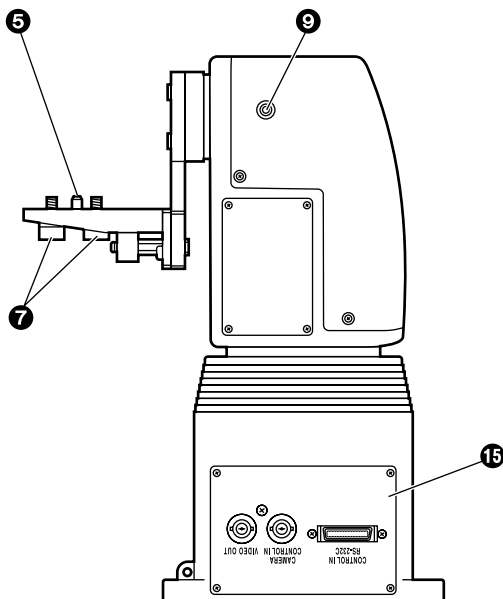
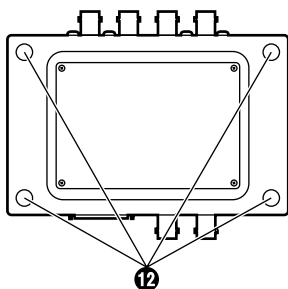
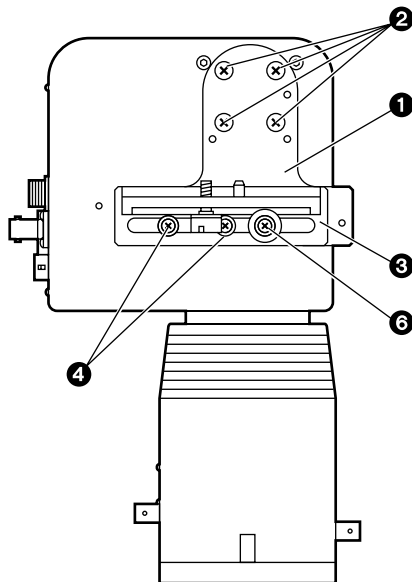
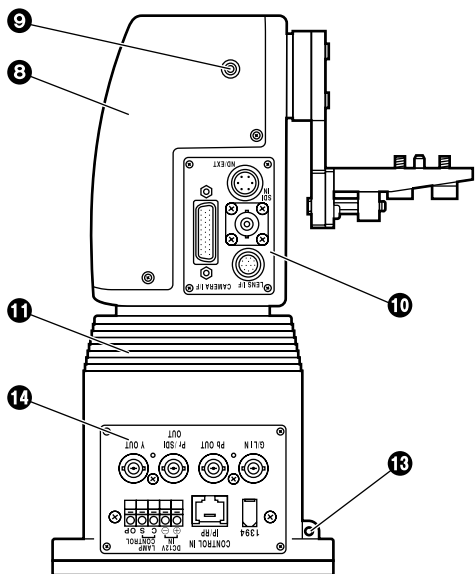

Parts and their functions

① Tilting arm

This tilts in the vertical direction.

② Tilting arm fixing screws

M4 × 12 mm (4 screws supplied)

③ Camera mounting plate

This is used to mount the convertible camera.

④ Guide screws

These are used to maintain the camera's balance and anchor the camera mounting plate.

⑤ Guide pin

This determines the mounting direction of the camera.

⑥ Guide roller

This serves as the fulcrum for maintaining the camera's balance.

⑦ Camera mounting screws (U1/4"-20 UNC)

These are used to mount the camera and anchor it securely.

⑧ Head

This rotates in the horizontal direction.

⑨ Tally lamps (× 2)

These light (red) in response to the selection signals.

⑩ Head connector panel

This is used for connection with the camera and lens.

⑪ Base

⑫ Pan/tilt head mounting holes

These four holes are used for mounting the pan/tilt head.

⑬ Safety wire mounting hole

This is used when attaching a wire to prevent the pan/tilt head from dropping.

⑭ Base connector rear panel

This is used for connection with a controller, multi-port hub or AC adapter for the pan/tilt head.

⑮ Base connector front panel

This is used for connection with a camera control or a personal computer.

Installation (The installation work must be performed by your dealer without fail.)

■ Assembling the pan/tilt head

Be absolutely sure to hold the pan/tilt head by the base when handling it.

- **Attaching the tilting arm**

Use the tilting arm fixing screws to attach the tilting arm. The way in which the arm is mounted differs depending on the direction in which it is installed. (See the figure below.)

Suspended installation

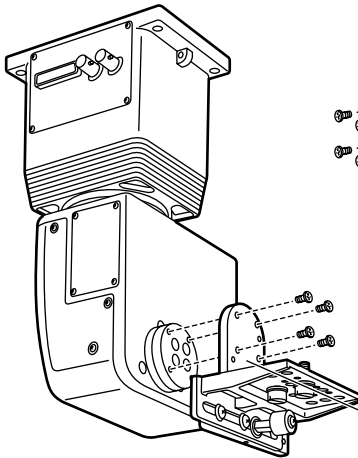

Stand-alone installation

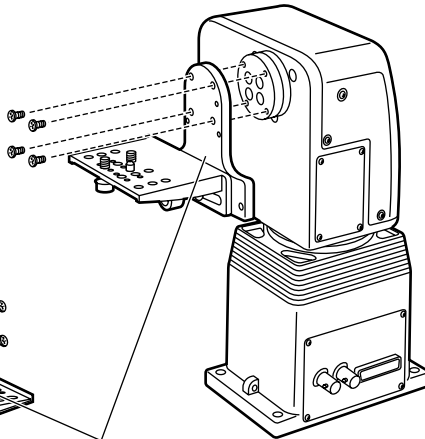

Tilting Arm

<Note>

Tighten up the screws securely to ensure that they will not come loose during use.

Installation (The installation work must be performed by your dealer without fail.)

■ Controller selection switch / installation direction switch / landing characteristics settings

The following switches are set when determining controller selections, stand alone settings and landing characteristics settings.

(RP501 / suspended installation / soft landing are the default settings.)

1. Remove the four head cover screws, and remove the cover slowly. (Take care not to disturb the tally LED lamp wiring connections when removing the cover.)

2. Set the SW1, SW2 and SW4 switches on the front printed circuit board as follows.

For AW-RP301/AW-RP305/AW-RP501/AW-RP505/AW-RP400:

Set SW1 switch to its right-side position (RP501). (Factory setting)

For AW-RP605A:

Set SW1 switch to its left-side position (RP605).

For suspended installation:

Set SW2 to its left-side position (HANGING). (Factory setting)

For stand-alone installation:

Set SW2 to its right-side position (DESKTOP).

For a soft landing:

Set SW4 switch No.4 to its top position (ON). (Factory setting)

For a precise landing:

Set SW4 switch No.4 to its bottom position (OFF).

3. Upon completion of the settings, return the head cover to its original position, and secure it with the screws (while taking care not to pinch the wires).

<Notes>

- Before setting the switches, make absolutely sure that the power of the AC adapter which is to be connected to the pan/tilt head is set to OFF.
- The controller selection and landing characteristics are not changed simply by selecting the switch positions. They are changed only after the power is turned off and back on again after the switches have been set.

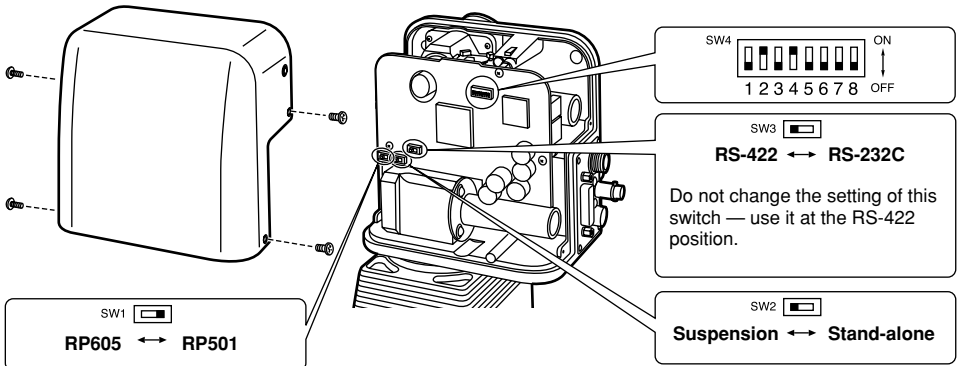

Installation (The installation work must be performed by your dealer without fail.)

■ Transmission signal selection setting

The switches on the COMP and CONNECTOR printed circuit boards must be set to correspond to the signals to be transmitted and components to be connected to the pan/tilt head.

(When shipped, the analog settings are supported.)

● Analog/IEEE1394 card settings

SDI/PR switch: PR
WEB/1394 switch: 1394
WEB/RP 422 switch: RP 422

● WEB card settings

SDI/PR switch: PR
WEB/1394 switch: WEB
WEB/RP 422 switch: WEB

● SDI settings

SDI/PR switch: SDI
WEB/1394 switch: 1394
WEB/RP 422 switch: RP 422

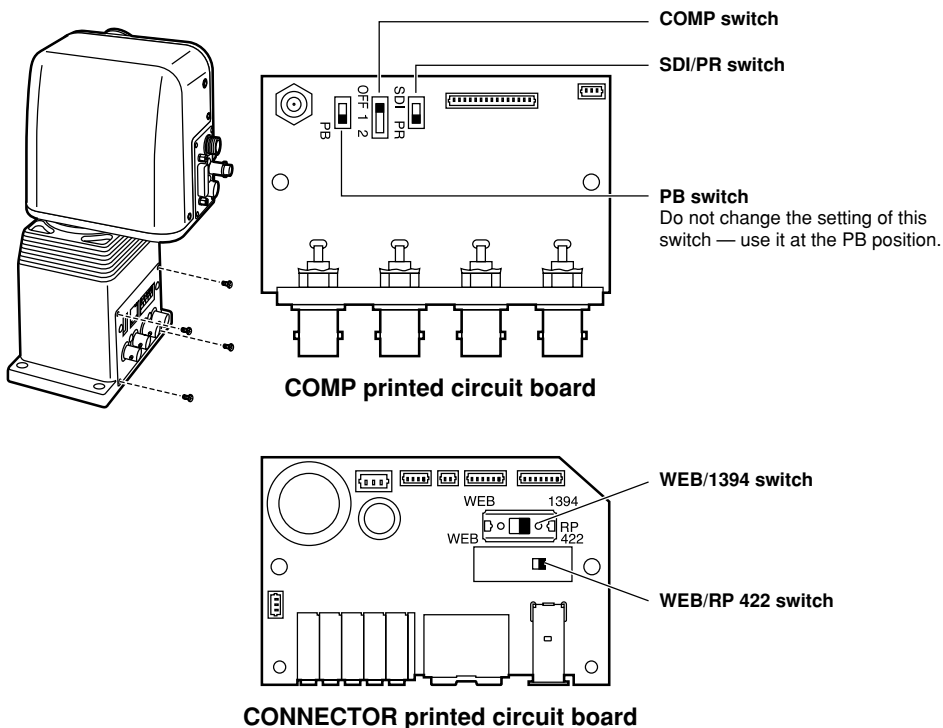

<Note>

- Before setting the switches, make absolutely sure that the power of the AC adapter which is to be connected to the pan/tilt head is set to OFF.

Installation (The installation work must be performed by your dealer without fail.)

■ **Setting the cable compensation circuit of video signals**

(COMP switch of the COMP printed circuit board is set to “OFF” in the default setting.)

① **When using the AW-RP501 controller or the AW-HB505 multiport hub (for transmissions using composite signals)**

When this controller (or multiport hub) has been connected to the pan/tilt head, it is permissible for the connecting cables to be up to 1640 ft. (500 m) long when a 10BASE-T straight cable (UTP category 5) and coaxial cable (BELDEN 8281) are used. However, when the cable length exceeds 984 ft. (300 m), follow the steps below to set the cable compensation circuit to “1”. (Default setting: OFF)

1. Remove the four screws on the base connector rear panel, and pull out the panel toward you.
2. Set the COMP switch on the COMP printed circuit board at the back of the panel to “1”.
3. Return the panel to its original position and secure it in place using the four screws.

② **When using the AW-RP605A controller**

When this controller has been connected to the pan/tilt head, it is permissible for the connecting cables to be up to 3333 ft. (1000 m) long when a 10BASE-T straight cable (UTP category 5) and coaxial cable (BELDEN 8281) are used. However, when the cable length exceeds 1640 ft. (500 m), follow the steps below to set the cable compensation circuit to “2”. (Default setting: OFF)

1. Remove the four screws of the base connector rear panel, and pull out the panel toward you.
2. Set the COMP switch on the COMP printed circuit board at the back of the panel to “2”.
3. Return the panel to its original position and secure it in place using the four screws.

③ **When using the AW-RP400 controller**

When this controller has been connected to the pan/tilt head, it is permissible for the connecting cables to be up to 1640 ft. (500 m) long when a 10BASE-T straight cable (UTP category 5) and coaxial cable (BELDEN 8281) are used.

Since the AW-RC400 cable compensation unit is capable of providing cable compensation for distances up to 1640 ft. (500 m), there is no need to change the setting established for the pan/tilt head's cable compensation circuit.

④ **When using a personal computer as the controller (for transmissions using component signals) and the configuration described in ①**

A separate cable compensation unit is required if the cables used to connect the pan/tilt head and controller are to be run over a long distance.

<Note>

- Before setting the switches, make absolutely sure that the power of the AC adapter which is to be connected to the pan/tilt head is set to OFF.

Installation (The installation work must be performed by your dealer without fail.)

■ Installing the pan/tilt head

Be absolutely sure to follow the instructions below when installing the pan/tilt head. Failure to do so may cause the pan/tilt head to slip out of position or fall.

- For wall
Do not install the pan/tilt head on any of its sides.
The wall should be capable of supporting a weight of at least four times the pan/tilt head with camera etc. weight 59.5 lb (27 kg).
- Make sure that the installation of the pan/tilt head has been completed before mounting the camera onto it.
- To mount the pan/tilt head, use the four mounting holes and secure it firmly in place.
- Have M6 hexagonal bolts ready as these must be used for mounting the pan/tilt head.
- The hexagonal bolts must be long enough to meet the requirement of “mounting material thickness plus 25 mm or longer”.
- Use flat washers, spring washers and hexagonal nuts with the hexagonal bolts, as shown in the figure.
- Use a wrench that fits the size of hexagonal bolt heads to tighten the hexagonal bolts.
- For suspended installation, pass a wire through the safety wire mounting hole, and fasten it securely to the ceiling or other structurally sound object.
- Have a wire ready which is strong enough to bear the weight of the entire pan/tilt head system (pan/tilt head, camera, lens and cable).
- Install the pan/tilt head so as to ensure that none of the components mounted on the pan/tilt head or cables will come into contact with any objects in the vicinity when the pan/tilt head rotates.

<Note>

When installing the pan/tilt head, refrain from forcibly turning the head or tilting arm by hand. Doing so may cause the unit to malfunction.

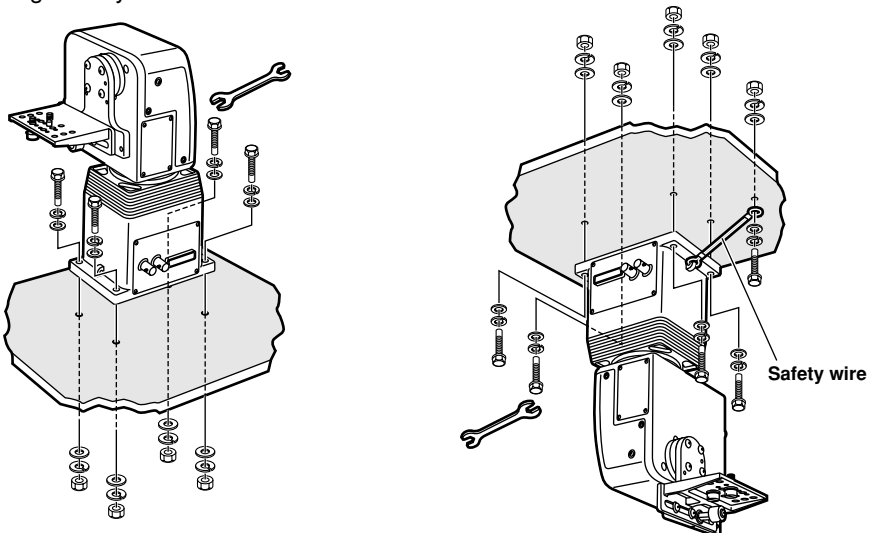

Installation (The installation work must be performed by your dealer without fail.)

■ Mounting the camera

The pan/tilt head's camera mounting section has a mechanism for maintaining the camera's balance that moves the camera mounting plate using a guide roller as a fulcrum. Use the described recommended lenses corresponding to the camera to be used. (Before mounting a lens other than recommended lenses, consult with your dealer.)

1. Change the position of guide pin **A** and/or the camera mounting screws in accordance with the following installation of the pan/tilt head before mounting the camera.
2. Adjust the balance by loosening the guide screws and moving the camera mounting plate.
3. Upon confirming the position where the balance is maintained, firmly tighten the guide screws. If the balance cannot be maintained, change the position of guide pin **B** or the positions of the guide screws, and adjust the balance again.

<Note>

- The guide roller is fixed in place. Do not remove the guide roller screw.

<Stand-alone installation>

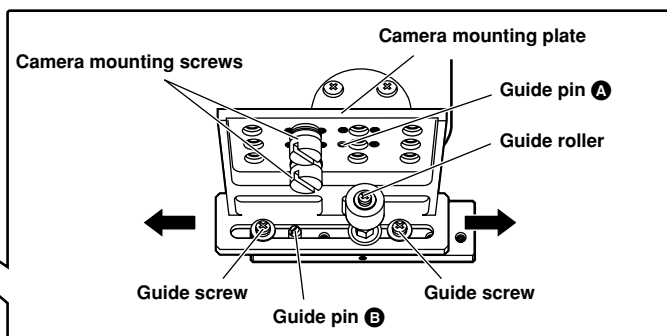
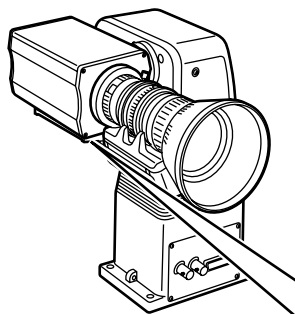

Change the position of the camera mounting screws and the guide pin **A** to change the installation.

<Suspended installation>

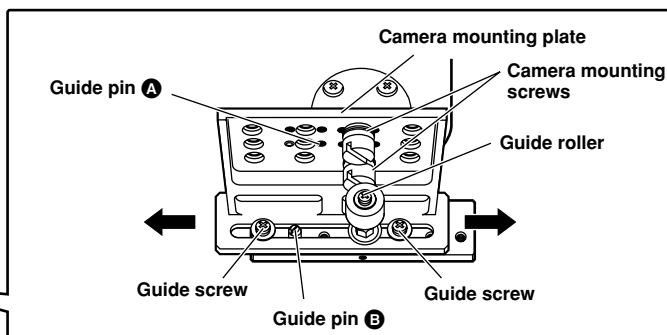
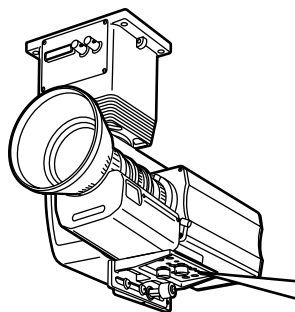

Installation (The installation work must be performed by your dealer without fail.)

• Stand-alone installation

<Mounting example: when the camera side is heavy>

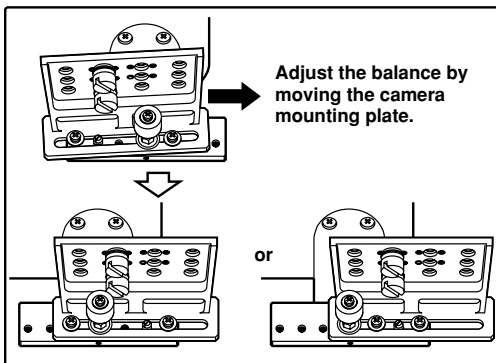
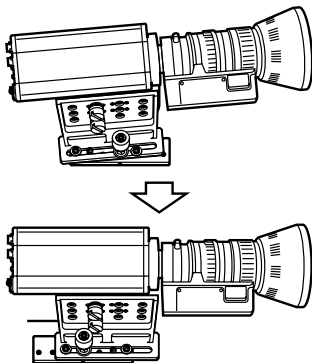

<Mounting example: when the lens side is heavy>

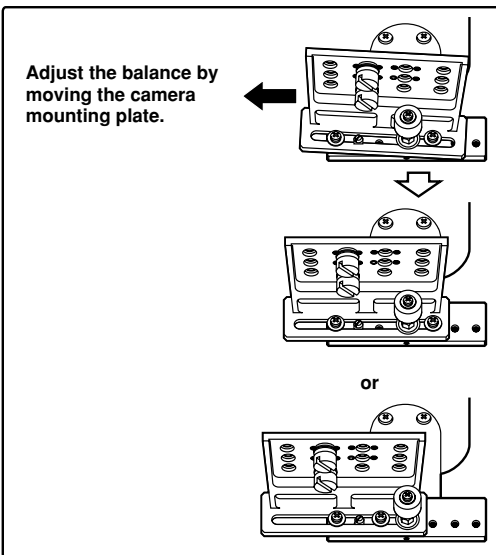
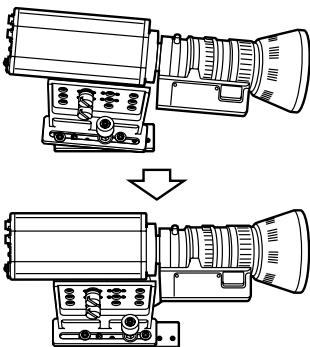

When the pan/tilt head is set at suspended installation, change the position of guide screws and guide pin ③ to adjust the balance as well as the stand-alone installation.

<Recommended lenses>

Camera	Lens
AW-E350	AW-LZ16MD55P AW-LZ10MD6
AW-E650	AW-LZ16MD73P
AW-E655	AW-LZ16AF7G
AW-E750	
AW-E860	AW-LZ17MD9AG

Installation (The installation work must be performed by your dealer without fail.)

● Attaching the chain

1. Attach one end of the chain to the pan/tilt head using a chain attachment screw (M4 × 8 mm: with flat washer/spring washer).
2. Position the other end of the chain over the screw hole on the top of the camera and attach it using a chain attachment screw (M4 × 6 mm: with flat washer/spring washer).

<Notes>

- Be sure to tighten all screws firmly with a screwdriver or similar tool.
- When the hole on the camera is M2.6, attach the chain with the M2.6 × 6 mm (with flat washer/spring washer) chain attachment screw.
- When using the AW-E860/AW-E750/AW-E655 camera, the mounting spacer must be attached to the top panel of the camera before attaching the chain. Position the end of the chain over the hole on the mounting spacer and attach it using a chain attachment screw (M4 × 6 mm: with flat washer/spring washer).

Be sure to tighten the mounting spacer and all screws firmly with a screwdriver or similar tool.

This chain is for use with the AW-E350, AW-E650, AW-E655, AW-E750 and AW-E860 convertible cameras. It cannot be used with any other camera. When attaching any other camera to the pan/tilt head, carefully check the pan/tilt head operation and that appropriate measures have been taken to ensure the camera does not fall.

With the AW-E350/AW-E650

Chain attachment screw
M4 × 6 mm or M2.6 × 6 mm:
with flat washer/spring washer

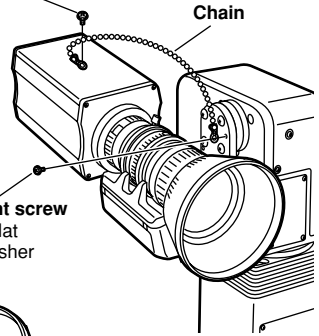

Chain attachment screw
M4 × 8 mm: with flat
washer/spring washer

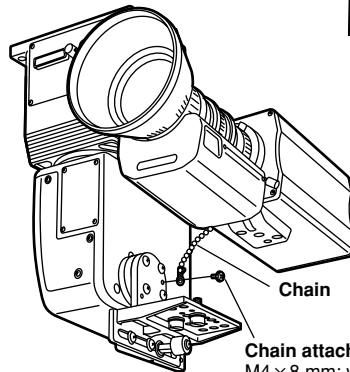

Chain attachment screw
M4 × 8 mm: with flat
washer/spring washer

With the AW-E655/AW-E750/AW-E860

Chain attachment screw
M4 × 6 mm: with
flat washer/spring
washer

Mounting spacer
(included with
the AW-E655/
AW-E750/
AW-E860)

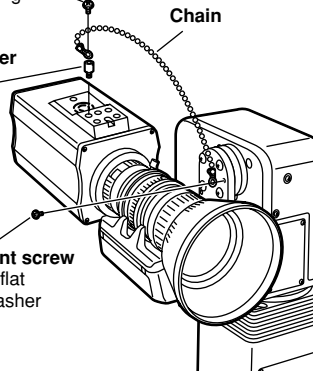

Chain attachment screw
M4 × 8 mm: with flat
washer/spring washer

Installation (The installation work must be performed by your dealer without fail.)

● Mounting a camera

When mounting a camera to the pan/tilt head, take appropriate measures to prevent the camera from falling or being stolen.

1. Place the camera on the camera mounting base and insert the guide pin into the guide hole on the camera.
2. Tighten the 2 camera mounting screws to fix the camera firmly in place.
3. After mounting the camera, check that it is firmly attached and that there is no play.

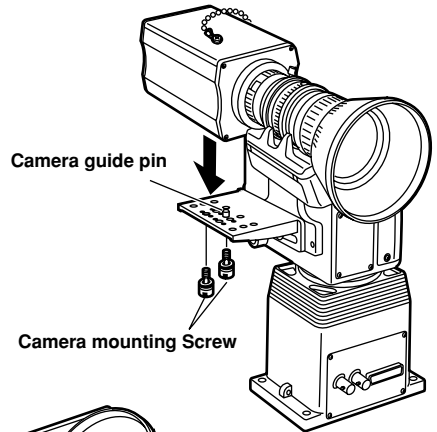

<Notes>

- Be sure to tighten all screws firmly with a screwdriver or similar tool.
- When there is only 1 hole on the camera, remove the 2 camera mounting screws from the camera mounting base, then insert 1 camera mounting screw into the center hole on the camera mounting plate and tighten it to fix the camera in place.

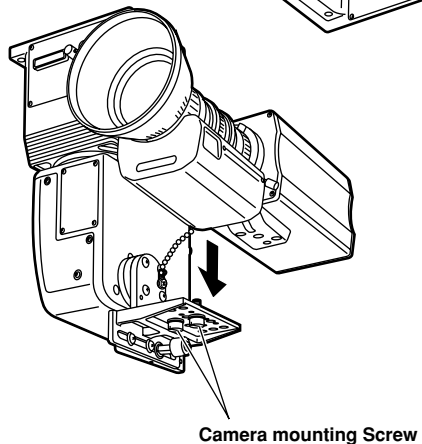

● Adjusting slack in the chain

The chain length allows for some degree of slack.

Remove any slack after attaching the camera to the pan/tilt head by twisting the chain around as shown in the figure at right, then firmly tighten the screw to fix it in place.

With the AW-E350/AW-E650

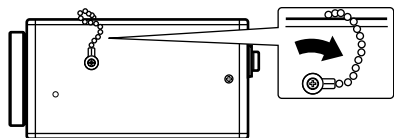

With the AW-E655/AW-E750/AW-E860

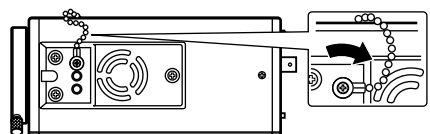

Connections

■ Connecting the connector panel (with the controller AW-RP501)

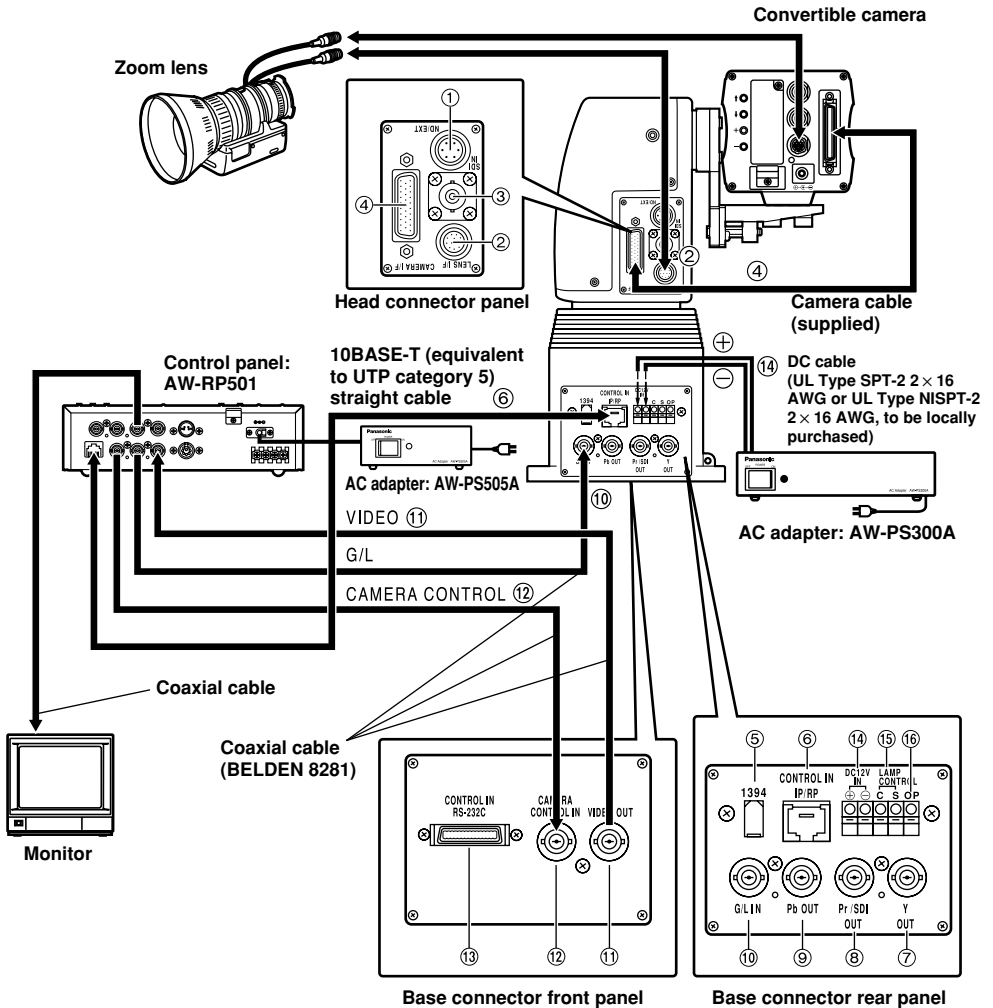

Connections

■ Connecting the connector panel (with the controller AW-RP505)

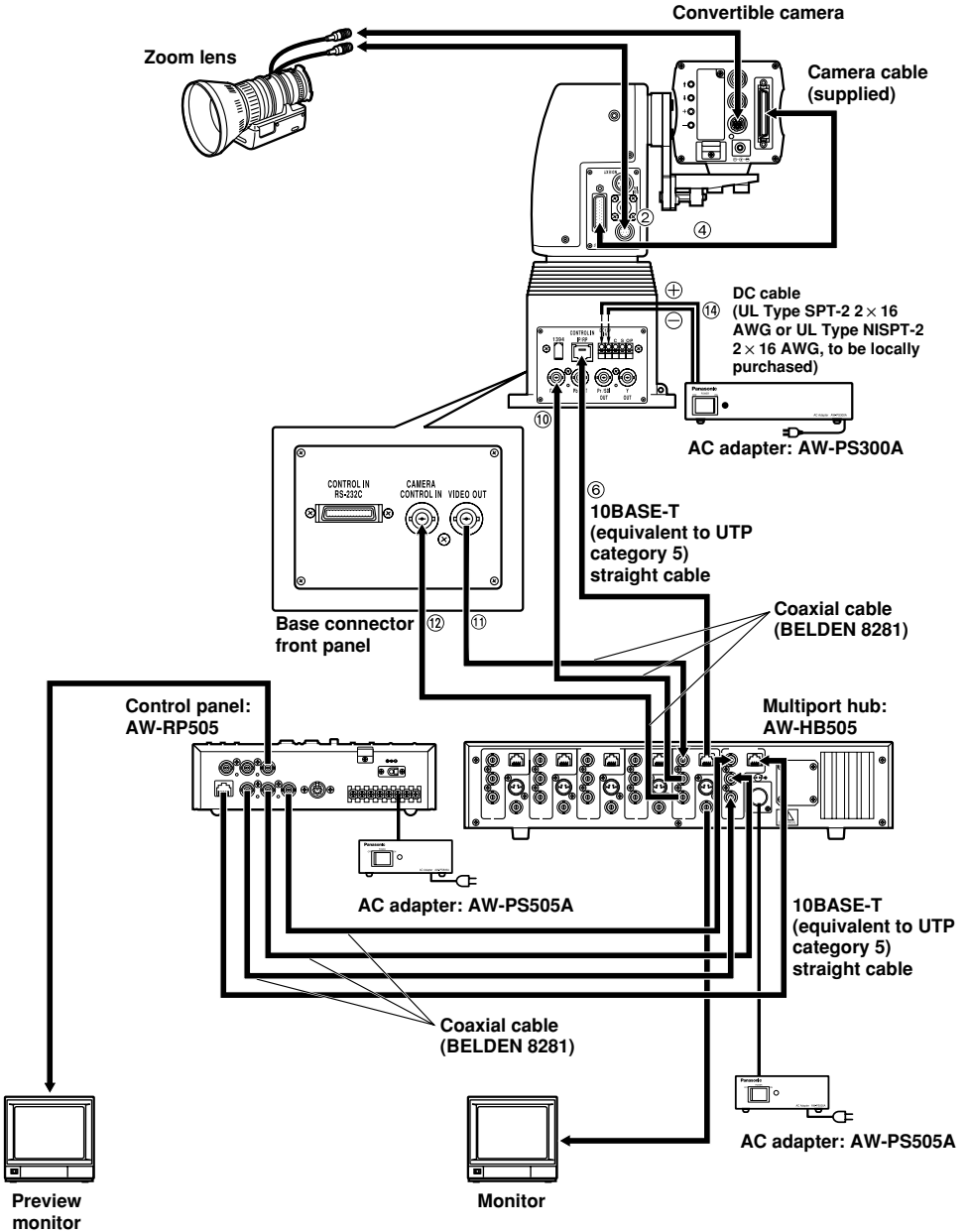

Connections

■ Connecting the connector panel (with the controller AW-RP605A)

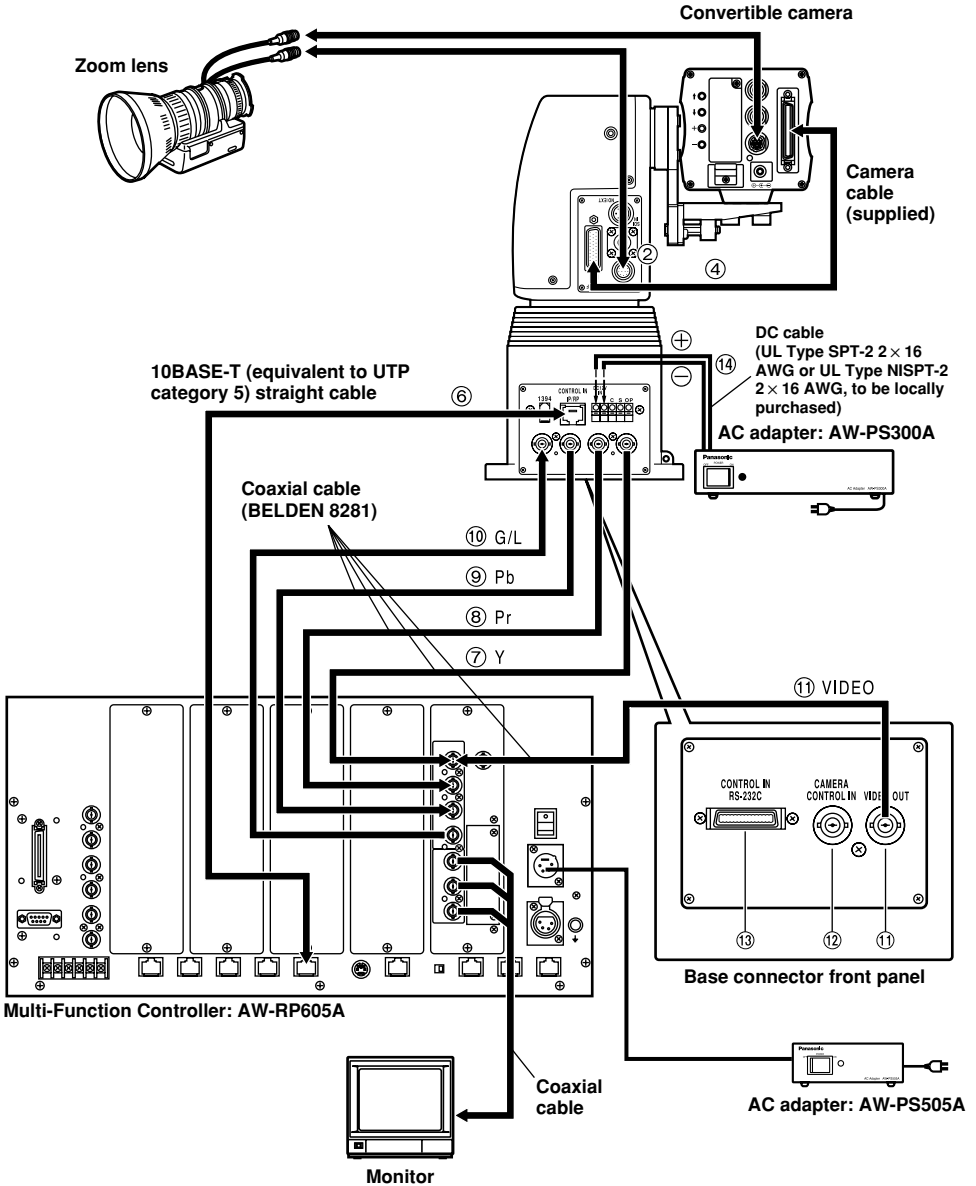

Connections

■ Connecting the connector panel (with the controller AW-RP400)

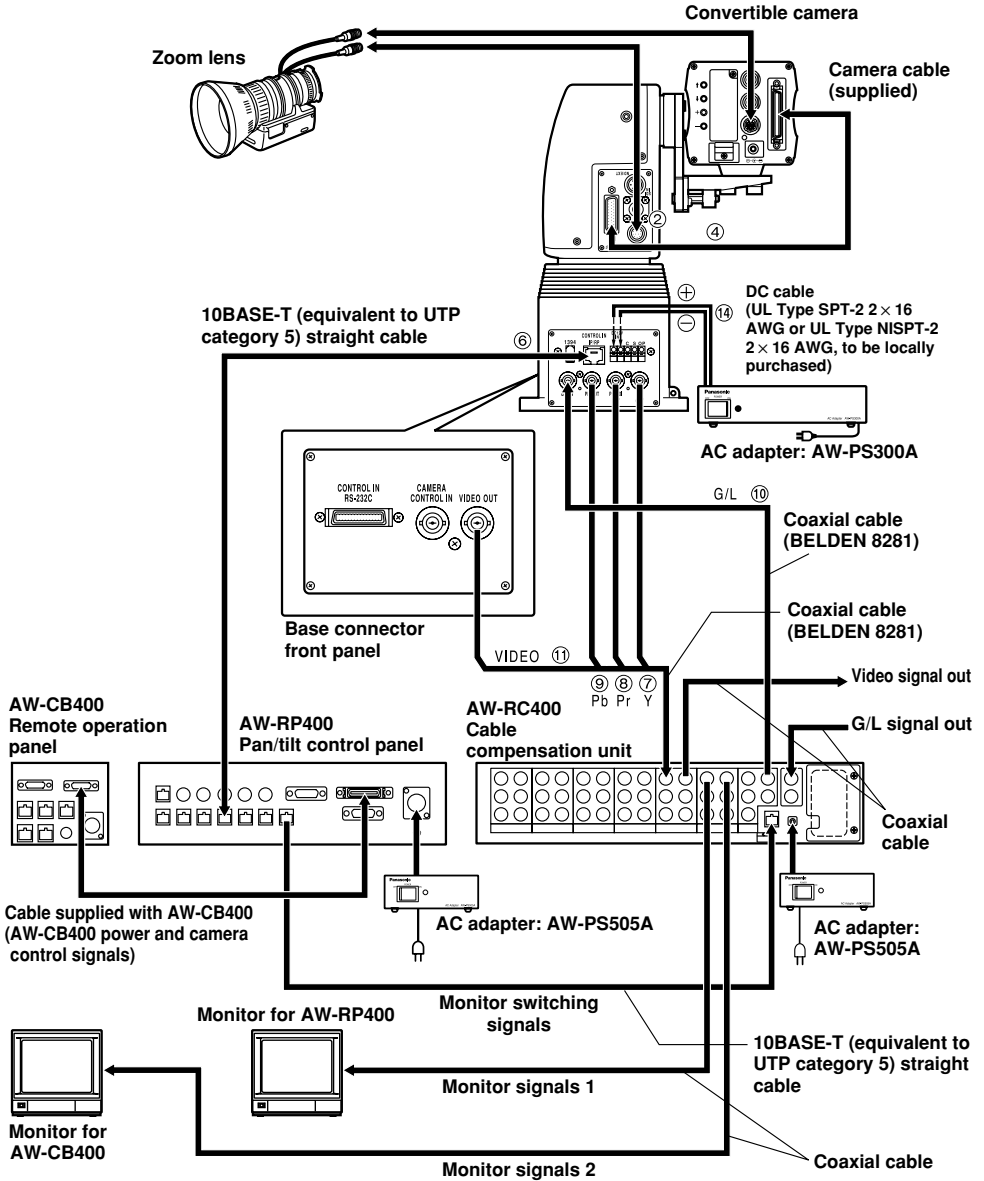

Connections

■ Connecting the connector panel (RS-232C control)

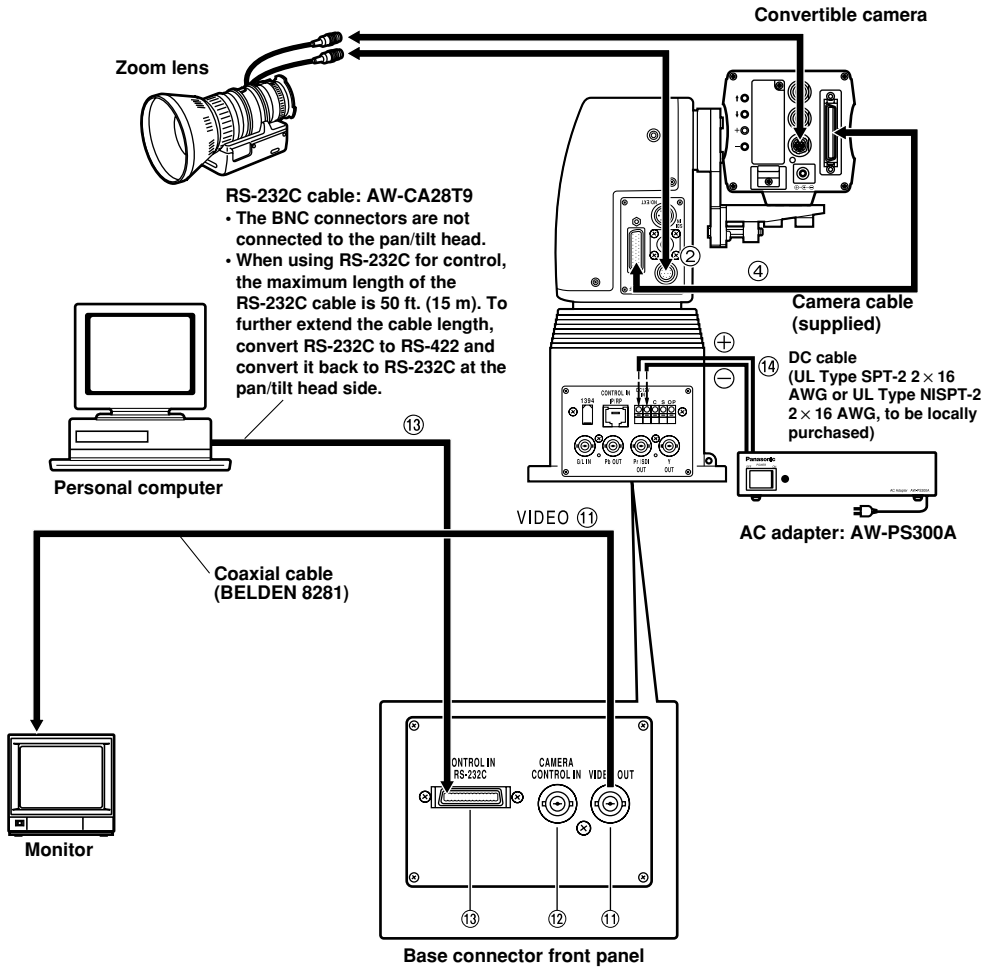

* When the coaxial cable for VIDEO ⑪ is to be run over a long distance, use a cable compensation unit immediately before the monitor input.

Connections

■ Head connector panel

The camera and lens control cables are connected to this panel.

① ND/EXT connector

This is for controlling the ND filter and lens extender of the power lens unit. Connect it when using a power lens unit equipped with an ND filter and lens extender function.

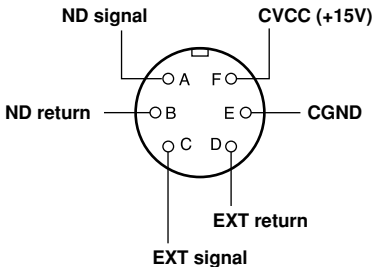

(As viewed from cable end)

④ CAMERA I/F connector

This is for convertible camera control. Connect this to the I/F REMOTE connector on the camera with the supplied camera cable.

② LENS I/F connector

This is for controlling the zoom/focus functions of the power lens unit. Connect the remote (zoom/focus) control cable of the power lens unit here.

③ SDI IN connector

This is for SDI signal input. Using a coaxial cable (BELDEN 8281), connect this with the SDI OUT connector of an SDI card (AW-PB504N, etc.) installed in the convertible camera.

Connections

■ Connecting the base connector rear panel and the base connector front panel

⑤ 1394 connector

This is for controlling the convertible camera, in which an IEEE 1394 card has been installed, and the pan/tilt head. As the connecting cable, use an IEEE 1394 cable.

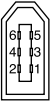

Pin No.	Signal
1	DC 12V
2	GND
3	TPB *
4	TPB
5	TPA *
6	TPA

<Note>

- This unit cannot be controlled directly using an IEEE1394 card. A convertible camera containing the plugged-in IEEE1394 card is needed.

⑥ CONTROL IN IP/RP connector

This is for camera/pan/tilt head control signals. Connect this to the PAN/TILT CONTROL OUT connector on the controllers AW-RP301/AW-RP305/AW-RP501/AW-RP505, or multiport hub AW-HB505, CONTROL OUT TO PAN/TILT HEAD connector on the controller AW-RP605A, or CONTROL OUT TO PAN/TILT connector on the controller AW-RP400. Use a 10BASE-T straight cable (UTP category 5) for the connecting cable.

<Notes>

- Depending on the controller to be used, it may be necessary to change the switch positions. For details on how to do this, refer to the section on “Controller selection switch settings” under “Installation” (page 10).

- For your safety, connect to an Ethernet network which does not exceed the voltage limit of the Ethernet connector.

⑦ Y OUT connector

This is for camera video signal output. Connect this to the Y IN connector on the controller or to a monitor, etc. Use a coaxial cable (BELDEN 8281) for the connecting cable.

⑧ Pr/SDI OUT connector

This is for camera video signal output. Connect this to the Pr IN connector on the controller or to a monitor, etc. SDI signals can be output when an SDI card (AW-PB504N, etc.) is installed in the convertible camera for use. Use a coaxial cable (BELDEN 8281) for the connecting cable.

<Note>

- To switch from Pr to SDI or vice versa, it is necessary to change the switch positions. For details on how to do this, refer to the section on “Transmission signal selection setting” under “Installation” (page 11).

Connections

⑨ Pb OUT connector

This is for camera video signal output. Connect this to the Pb IN connector on the controller or to a monitor, etc. Use a coaxial cable (BELDEN 8281) for the connecting cable.

⑩ G/L IN connector

This is for genlock signal input. Connect this to the G/L OUT connector on the controller. Use a coaxial cable (BELDEN 8281) for the connecting cable.

⑪ VIDEO OUT connector

This is for camera video signal output. Connect this to the VIDEO IN connector on the controller or to a monitor, etc. Use a coaxial cable (BELDEN 8281) for the connecting cable.

⑫ CAMERA CONTROL IN connector

This is for camera control signal input. Connect this to the CAMERA CONTROL OUT connector on the controllers AW-RP501/AW-RP505, or multiport hub AW-HB505. Use a coaxial cable (BELDEN 8281) for the connecting cable.

⑬ CONTROL IN RS-232C connector

This is for RS-232C control signal input from the personal computer. Use the AW-CA28T9 cable (option) for the connecting cable. The AW-CA28T9 is 10m long. When extending the length, please use an RS-422, converting back to the RS-232C at the pan/tilt head.

<Notes>

- The personal computer can be connected with the controllers AW-RP301/AW-RP305/AW-RP501/AW-RP505 at the same time. (When connecting with the controllers AW-RP605A/AW-RP400 at the same time, connect with controller's REMOTE terminal.) In that case, the control source last used for operation is given priority.
- When the AW-RP301, AW-RP305, AW-RP501 or AW-RP505 controller and a personal computer are to be used at the same time, the camera is controlled by the controller if the controller is connected to the ⑫ CAMERA CONTROL IN connector. If this connector is not connected, it is controlled by the personal computer.
- Information such as pan/tilt head position, lens zoom, focus, iris, etc. can be accessed by the computer however, white balance set by the controller cannot be accessed.

Connections

■ Connecting the AC adapter for use with the pan/tilt head

Connect the pan/tilt head with the AW-PS300A AC adapter designed for use with the pan/tilt head.

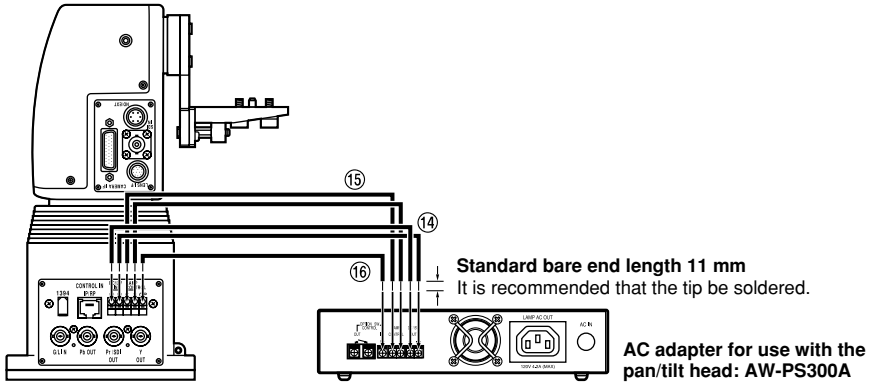

⑭ DC 12V IN terminal board

Connect this to the DC 15V OUT connector on the AC adapter (AW-PS300A). (The voltage output from the AC adapter is set to 15V; this takes into consideration the voltage drops due to the possible extension of the DC cable between the pan/tilt head and AC adapter.)

Make sure that the positive ⊕ and negative ⊖ ends of the wires are connected to the same signs on the connector.

Use a cable with a nominal cross section of 1.25 mm² or more that meets the UL specifications for the connection. The maximum allowable cable length is 98.4 ft. (30 meters).

Applicable (usable) wire

- UL Type SPT-2 2 × 16 AWG or
- UL Type NISPT-2 2 × 16 AWG

⑮ LAMP CONTROL terminal board

Connect this only when the power of a halogen lamp is to be supplied from the AC adapter (AW-PS300A).

This connector is connected to LAMP

CONTROL on the AC adapter for the pan/tilt head.

The symbols C and S on the wires must match the same symbols on the connector.

Use a cable with a nominal cross section of 0.3 mm² or more that meets the UL specifications for the connection. The maximum allowable cable length is 98.4 ft. (30 meters).

⑯ OP terminal board

Connect this only when the OP SW CONTROL OUT connector on the AC adapter (AW-PS300A) is to be used. Connect it to the OPTION SW CONTROL IN connector on the AC adapter (AW-PS300A).

Use a cable with a nominal cross section of 0.3 mm² or more that meets the UL specifications for the connection. The maximum allowable cable length is 98.4 ft. (30 meters).

Connections

■ Connection examples

- ① When the camera and pan/tilt head are to be controlled by the AW-RP501 control panel for transmitting composite signals

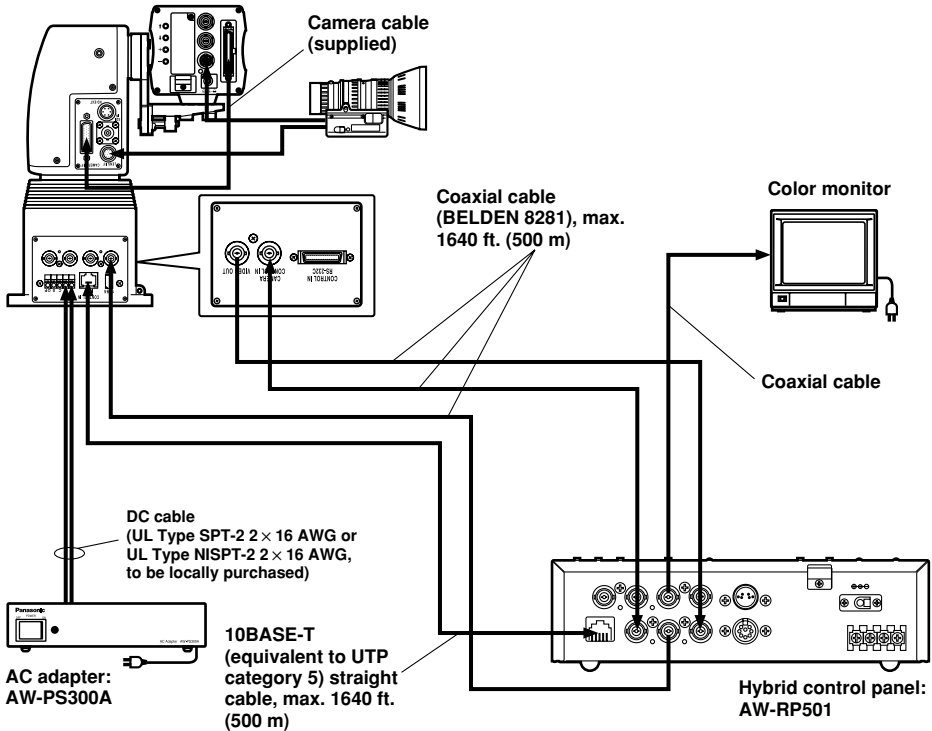

- Use the supplied camera cable to connect the unit with the convertible camera.
- Set controller selection switch SW1 to the right side (RP501), and select the transmission signal selection setting that supports the analog/IEEE1394 card.
- Use a 10BASE-T straight cable (UTP category 5) to connect the unit's CONTROL IN IP/RP connector with the controller's PAN TILT CONTROL OUT connector.
- Use a coaxial cable (BELDEN 8281) to connect the unit's CAMERA CONTROL IN connector with the controller's CAMERA CONTROL OUT connector.
- Use a coaxial cable (BELDEN 8281) to connect the unit's VIDEO OUT connector with the controller's VIDEO IN connector.
- Use a coaxial cable to connect the controller's VIDEO OUT connector with the color monitor's VIDEO input connector.
- Check that the pan/tilt head and camera can be controlled by the controller.

Connections

② When the camera and pan/tilt head are to be controlled by the AW-RP501 control panel for transmitting component signals

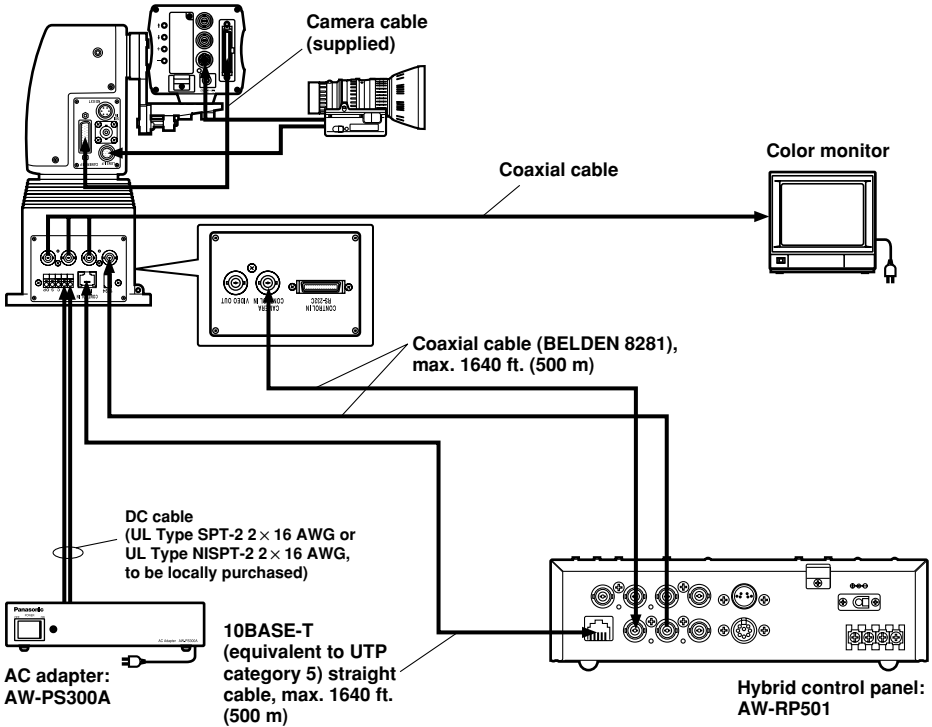

- Use the supplied camera cable to connect the unit with the convertible camera.
- Set controller selection switch SW1 to the right side (RP501), and select the transmission signal selection setting that supports the analog/IEEE1394 card.
- Use a 10BASE-T straight cable (UTP category 5) to connect the unit's CONTROL IN IP/RP connector with the controller's PAN TILT CONTROL OUT connector.
- Use a coaxial cable (BELDEN 8281) to connect the unit's CAMERA CONTROL IN connector with the controller's CAMERA CONTROL OUT connector.
- Use coaxial cables to connect the unit's Y OUT connector, Pr/SDI OUT connector and Pb OUT connector with the component input connectors on the color monitor.
- Check that the pan/tilt head and camera can be controlled by the controller.
- Transmitting component signals over a long distance requires a separate cable compensation unit.

Connections

③ When the camera and pan/tilt head are to be controlled by the AW-RP501 control panel for transmitting SDI signals

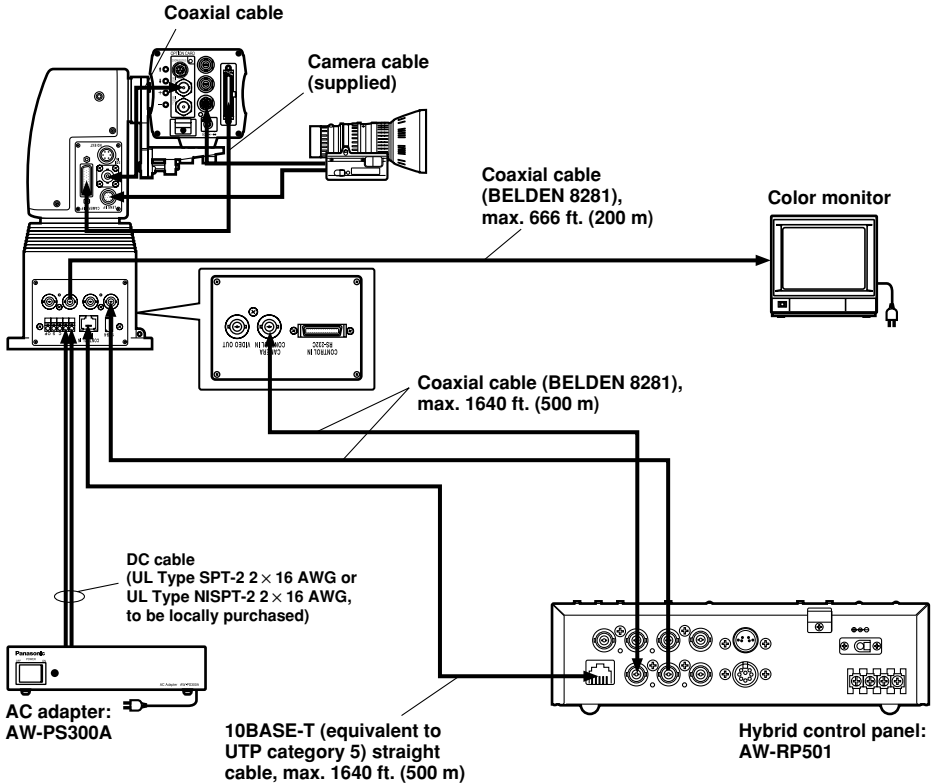

- Use the supplied camera cable to connect the unit with the convertible camera containing the plugged-in SDI card (such as the AW-PB504N).
- Use a coaxial cable to connect the SDI card's SDI OUT connector with the unit's SDI IN connector. Adjust the cable to a length at which the pan/tilt head will move smoothly.
- Set controller selection switch SW1 to the right side (RP501), and select the transmission signal selection setting that supports the SDI card.
- Use a 10BASE-T straight cable (UTP category 5) to connect the unit's CONTROL IN IP/RP connector with the controller's PAN TILT CONTROL OUT connector.
- Use a coaxial cable (BELDEN 8281) to connect the unit's CAMERA CONTROL IN connector with the controller's CAMERA CONTROL OUT connector.
- Use a coaxial cable to connect the unit's Pr/SDI OUT connector with the color monitor's SDI input connector.
- Check that the pan/tilt head and camera can be controlled by the controller.

Connections

- ④ When the camera and pan/tilt head are to be controlled by the AW-RP505 control panel for transmitting composite signals

Genlock signals must be supplied if a multiple number of cameras and pan/tilt heads are to be used.

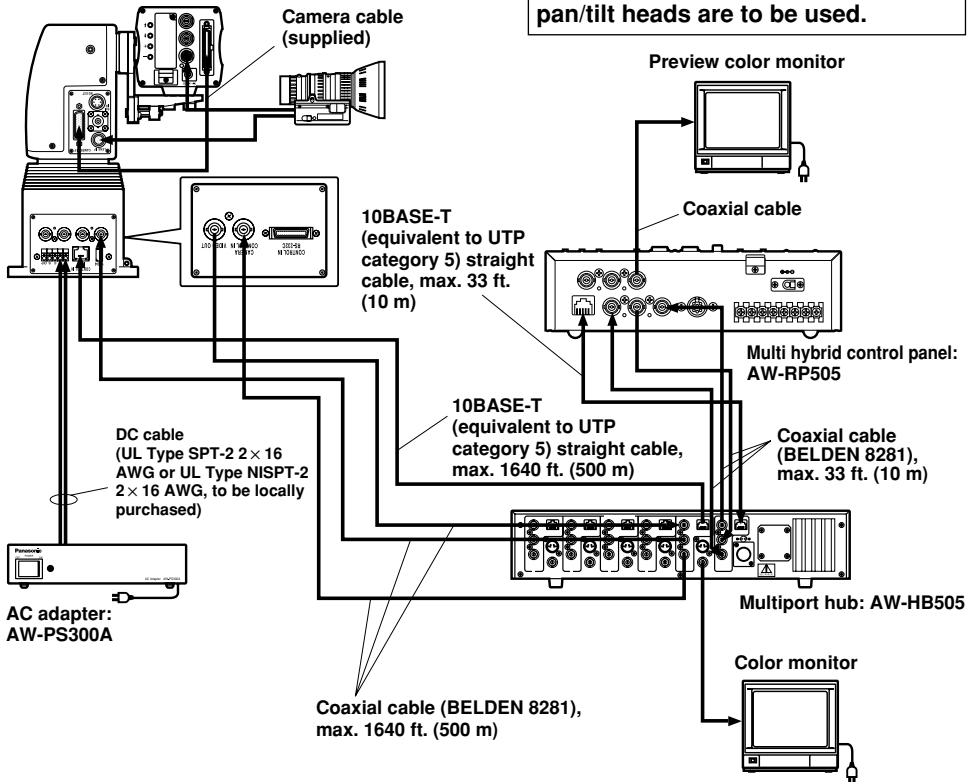

- Use the supplied camera cable to connect the unit with the convertible camera.
- Set controller selection switch SW1 to the right side (RP501), and select the transmission signal selection setting that supports the analog/IEEE1394 card.
- Use a 10BASE-T straight cable (UTP category 5) to connect the unit's CONTROL IN IP/RP connector with the multiport hub's PAN/TILT CONTROL OUT connector.
- Use a coaxial cable (BELDEN 8281) to connect the unit's CAMERA CONTROL IN connector with the multiport hub's CAMERA CONTROL OUT connector.
- Use a coaxial cable (BELDEN 8281) to connect the unit's VIDEO OUT connector with the multiport hub's VIDEO IN connector.
- Use a 10BASE-T straight cable (UTP category 5) to connect the multiport hub's PAN/TILT CONTROL IN connector with the controller's PAN/TILT CONTROL OUT connector.
- Use a coaxial cable (BELDEN 8281) to connect the multiport hub's CAMERA CONTROL IN connector with the controller's CAMERA CONTROL OUT connector.
- Use a coaxial cable (BELDEN 8281) to connect the multiport hub's PREVIEW OUT connector with the controller's PREVIEW IN connector.
- Connect the multiport hub's VIDEO OUT connector to the color monitor's VIDEO input connector.
- Check that the pan/tilt head and camera can be controlled by the controller.

Connections

⑤ When the camera and pan/tilt head are to be controlled by the AW-RP505 control panel for transmitting component signals

Genlock signals must be supplied if a multiple number of cameras and pan/tilt heads are to be used.

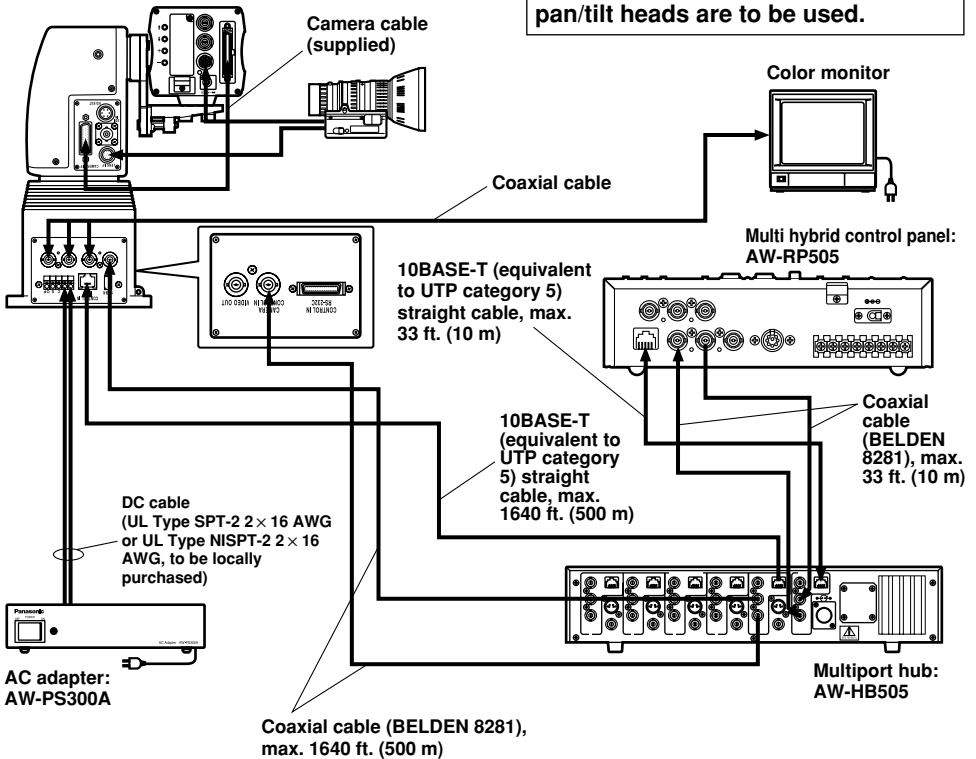

- Use the supplied camera cable to connect the unit with the convertible camera.
- Set controller selection switch SW1 to the right side (RP501), and select the transmission signal selection setting that supports the analog/IEEE1394 card.
- Use a 10BASE-T straight cable (UTP category 5) to connect the unit's CONTROL IN IP/RP connector with the multiport hub's PAN/TILT CONTROL OUT connector.
- Use a coaxial cable (BELDEN 8281) to connect the unit's CAMERA CONTROL IN connector with the multiport hub's CAMERA CONTROL OUT connector.
- Use a 10BASE-T straight cable (UTP category 5) to connect the multiport hub's PAN/TILT CONTROL IN connector with the controller's PAN/TILT CONTROL OUT connector.
- Use a coaxial cable (BELDEN 8281) to connect the multiport hub's CAMERA CONTROL IN connector with the controller's CAMERA CONTROL OUT connector.
- Use coaxial cables to connect the unit's Y OUT connector, Pr/SDI OUT connector and Pb OUT connector with the component input connectors on the color monitor.
- Check that the pan/tilt head and camera can be controlled by the controller.
- Transmitting component signals over a long distance requires a separate cable compensation unit.

Connections

⑥ When the camera and pan/tilt head are to be controlled by the AW-RP505 control panel for transmitting SDI signals

Genlock signals must be supplied if a multiple number of cameras and pan/tilt heads are to be used.

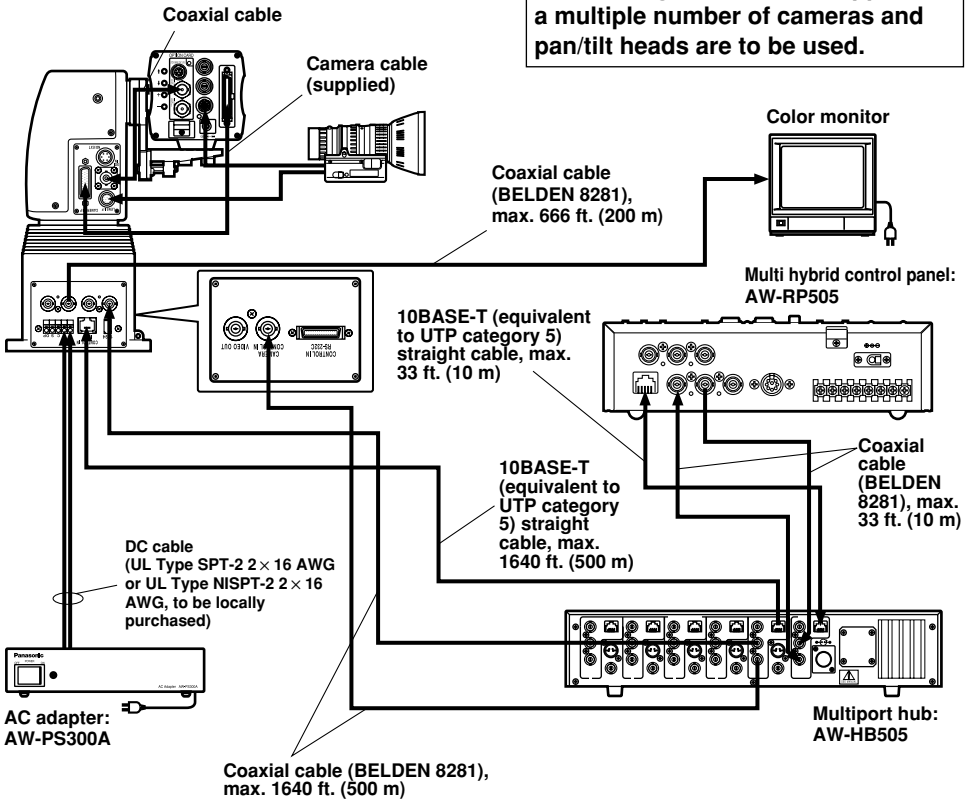

- Use the supplied camera cable to connect the unit with the convertible camera containing the plugged-in SDI card (such as the AW-PB504N).
- Use a coaxial cable to connect the SDI card's SDI OUT connector with the unit's SDI IN connector. Adjust the cable to a length at which the pan/tilt head will move smoothly.
- Set controller selection switch SW1 to the right side (RP501), and select the transmission signal selection setting that supports the SDI card.
- Use a 10BASE-T straight cable (UTP category 5) to connect the unit's CONTROL IN IP/RP connector with the multiport hub's PAN/TILT CONTROL OUT connector.
- Use a coaxial cable (BELDEN 8281) to connect the unit's CAMERA CONTROL IN connector with the multiport hub's CAMERA CONTROL OUT connector.
- Use a 10BASE-T straight cable (UTP category 5) to connect the multiport hub's PAN/TILT CONTROL IN connector with the controller's PAN/TILT CONTROL OUT connector.
- Use a coaxial cable (BELDEN 8281) to connect the multiport hub's CAMERA CONTROL IN connector with the controller's CAMERA CONTROL OUT connector.
- Use a coaxial cable to connect the unit's Pr/SDI OUT connector with the color monitor's SDI input connector.
- Check that the pan/tilt head and camera can be controlled by the controller.

Connections

⑦ When the camera and pan/tilt head are to be controlled by the AW-RP605A multi-function controller for transmitting composite or component signals

Genlock signals must be supplied if a multiple number of cameras and pan/tilt heads are to be used.

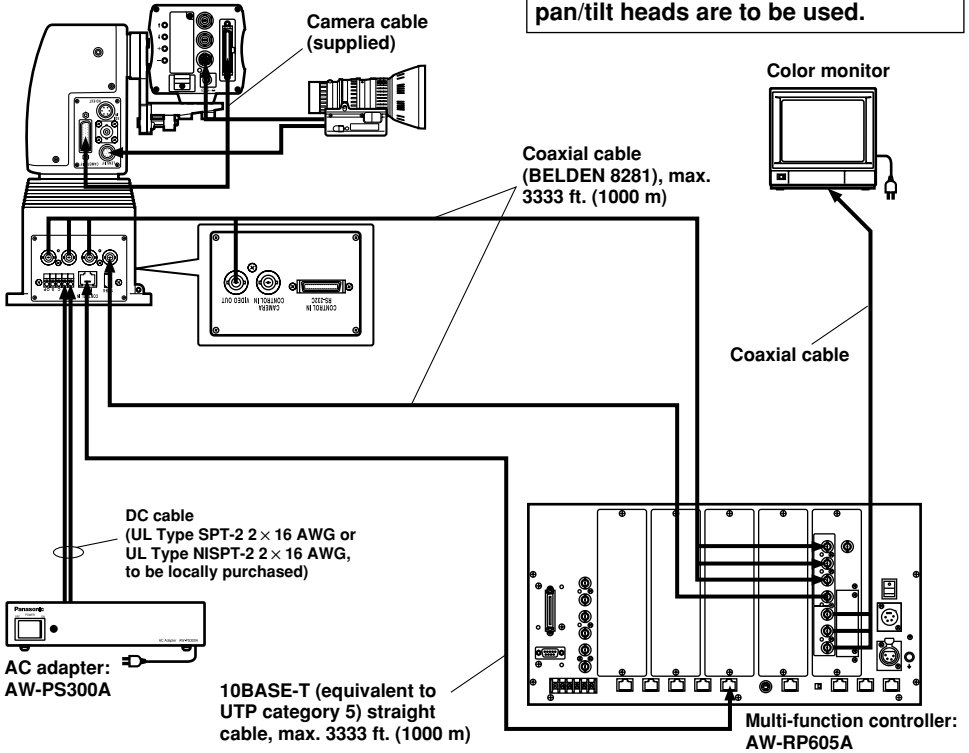

- Use the supplied camera cable to connect the unit with the convertible camera.
- Set controller selection switch SW1 to the left side (RP605), and select the transmission signal selection setting that supports the analog/IEEE1394 card.
- Use a 10BASE-T straight cable (UTP category 5) to connect the unit's CONTROL IN IP/RP connector with the controller's CONTROL OUT TO PAN/TILT HEAD connector.
- Use a coaxial cable (BELDEN 8281) to connect the unit's VIDEO OUT connector with the controller's VIDEO/Y IN connector (when composite signals are to be transmitted).
- Use a coaxial cable (BELDEN 8281) to connect the unit's Y OUT connector, Pr/SDI OUT connector and Pb OUT connector with the controller's VIDEO/Y IN connector, Pr IN connector and Pb IN connector (when component signals are to be transmitted).
- Use a coaxial cable to connect the controller's VIDEO/Y OUT connector, Pr OUT connector and Pb OUT connector with the color monitor's VIDEO input connector or component input connectors.
- Check that the pan/tilt head and camera can be controlled by the controller.

Connections

- ⑧ When the camera and pan/tilt head are to be controlled by the AW-RP605A multi-function controller for transmitting SDI signals

Genlock signals must be supplied if a multiple number of cameras and pan/tilt heads are to be used.

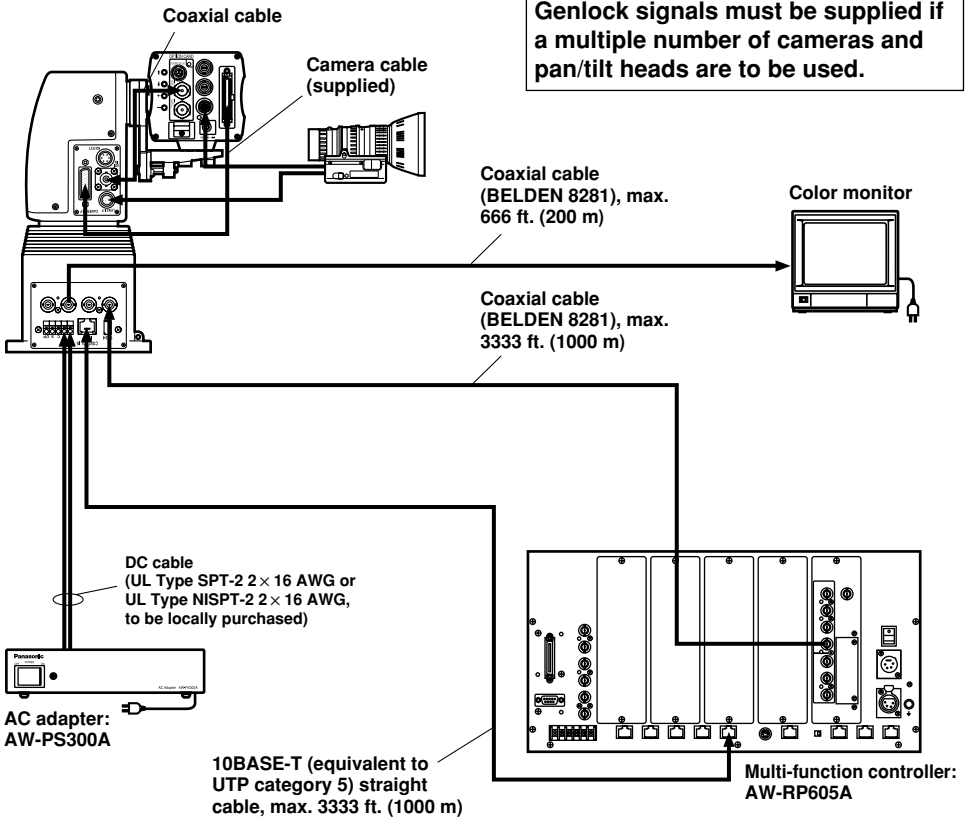

- Use the supplied camera cable to connect the unit with the convertible camera containing the plugged-in SDI card (such as the AW-PB504N).
- Use a coaxial cable to connect the SDI card's SDI OUT connector with the unit's SDI IN connector. Adjust the cable to a length at which the pan/tilt head will move smoothly.
- Set controller selection switch SW1 to the left side (RP605), and select the transmission signal selection setting that supports the SDI card.
- Use a 10BASE-T straight cable (UTP category 5) to connect the unit's CONTROL IN IP/RP connector with the controller's CONTROL OUT TO PAN/TILT HEAD connector.
- Use a coaxial cable to connect the unit's Pr/SDI OUT connector with the color monitor's SDI input connector.
- Check that the pan/tilt head and camera can be controlled by the controller.

Connections

⑨ When the pan/tilt head is to be controlled by the AW-RP400 pan/tilt head control panel for transmitting composite or component signals (and the AW-CB400 remote operation panel is used to control the camera)

Genlock signals must be supplied if a multiple number of cameras and pan/tilt heads are to be used.

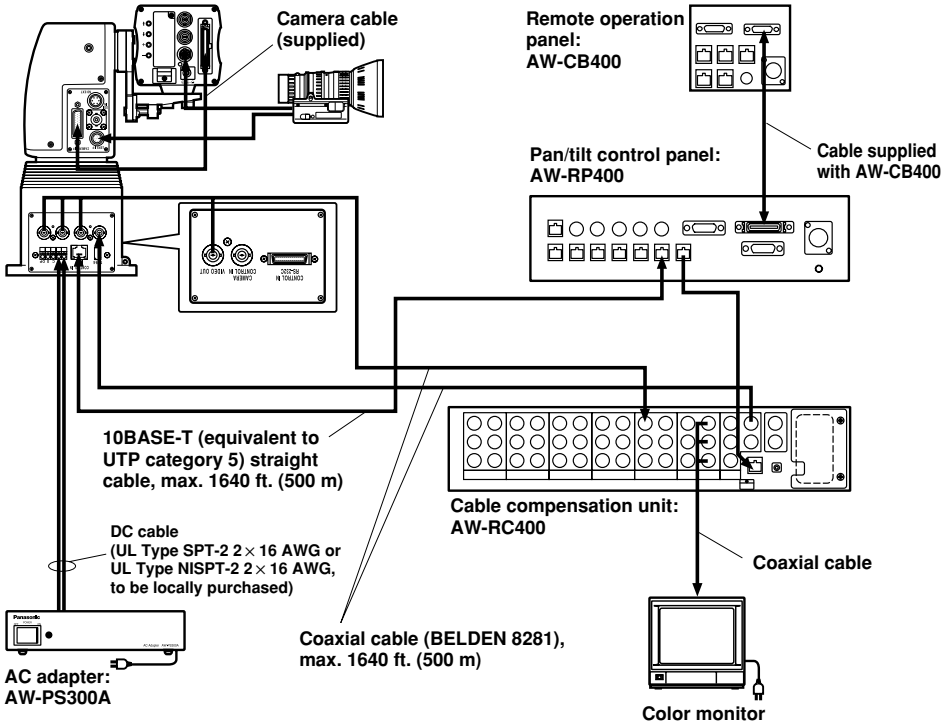

- Use the supplied camera cable to connect the unit with the convertible camera.
- Set controller selection switch SW1 to the right side (RP501), and select the transmission signal selection setting that supports the analog/IEEE1394 card.
- Use a 10BASE-T straight cable (UTP category 5) to connect the unit's CONTROL IN IP/RP connector with the controller's CONTROL OUT TO PAN/TILT HEAD connector.
- Use a coaxial cable (BELDEN 8281) to connect the unit's VIDEO OUT connector with the cable compensation unit's Y VIDEO IN connector (when composite signals are to be transmitted).
- Use a coaxial cable (BELDEN 8281) to connect the unit's Y OUT connector, Pr/SDI OUT connector and Pb OUT connector with the cable compensation unit's Y VIDEO IN connector, PR C IN connector and PB IN connector (when component signals are to be transmitted).
- Use a coaxial cable to connect the cable compensation unit's Y VIDEO IN connector, PR C IN connector and PB IN connector with the color monitor's VIDEO input connector or component input connectors.
- Use the cable supplied with the remote operation panel to connect the controller's CAMERA CONTROL IN FROM ROP connector with the remote operation panel's CONTROL OUT TO CONTROL PANEL connector.
- Check that the pan/tilt head and camera can be controlled by the controller.

Connections

⑩ When the pan/tilt head is to be controlled by the AW-RP400 pan/tilt head control panel for transmitting SDI signals (and the AW-CB400 remote operation panel is used to control the camera)

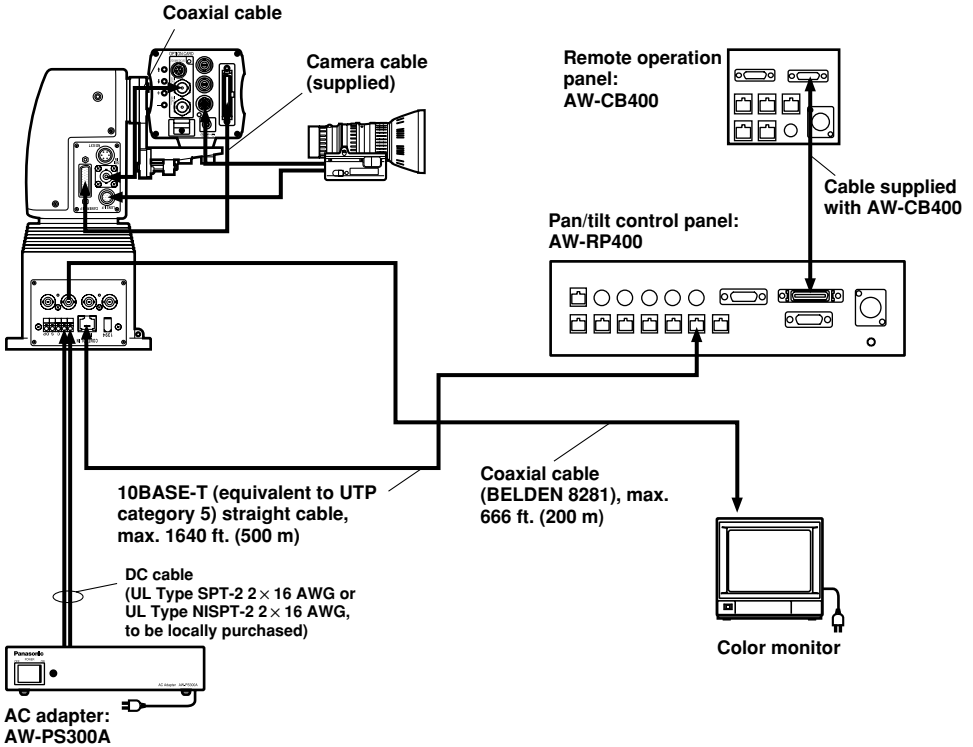

- Use the supplied camera cable to connect the unit with the convertible camera containing the plugged-in SDI card (such as the AW-PB504N).
- Use a coaxial cable to connect the SDI card's SDI OUT connector with the unit's SDI IN connector. Adjust the cable to a length at which the pan/tilt head will move smoothly.
- Set controller selection switch SW1 to the right side (RP501), and select the transmission signal selection setting that supports the SDI card.
- Use a 10BASE-T straight cable (UTP category 5) to connect the unit's CONTROL IN IP/RP connector with the controller's CONTROL OUT TO PAN/TILT HEAD connector.
- Use a coaxial cable to connect the unit's Pr/SDI OUT connector with the color monitor's SDI input connector.
- Use the cable supplied with the remote operation panel to connect the controller's CAMERA CONTROL IN FROM ROP connector with the remote operation panel's CONTROL OUT TO CONTROL PANEL connector.
- Check that the pan/tilt head and camera can be controlled by the controller.

Connections

① When the pan/tilt head is to be controlled by the AW-RP400 pan/tilt head control panel for transmitting composite or component signals (and the WV-CB700A remote control box is used to control the camera)

Genlock signals must be supplied if a multiple number of cameras and pan/tilt heads are to be used.

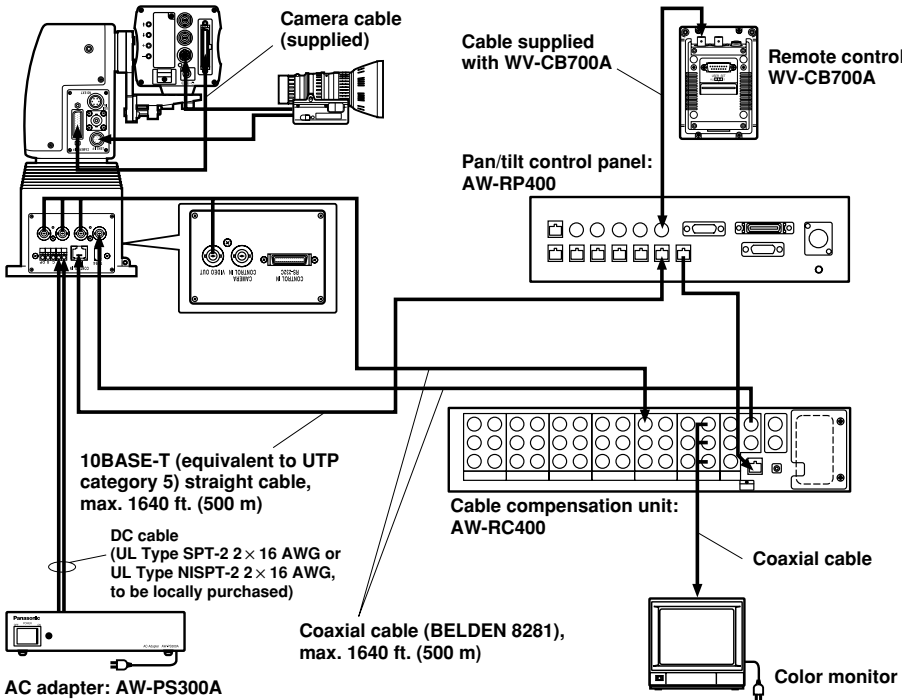

- Use the supplied camera cable to connect the unit with the convertible camera.
- Set controller selection switch SW1 to the right side (RP501), and select the transmission signal selection setting that supports the analog/IEEE1394 card.
- Use a 10BASE-T straight cable (UTP category 5) to connect the unit's CONTROL IN IP/RP connector with the controller's CONTROL OUT TO PAN/TILT HEAD connector.
- Use a coaxial cable (BELDEN 8281) to connect the unit's VIDEO OUT connector with the cable compensation unit's Y VIDEO IN connector (when composite signals are to be transmitted).
- Use a coaxial cable (BELDEN 8281) to connect the unit's Y OUT connector, Pr/SDI OUT connector and Pb OUT connector with the cable compensation unit's Y VIDEO IN connector, PR C IN connector and PB IN connector (when component signals are to be transmitted).
- Use a coaxial cable to connect the cable compensation unit's Y VIDEO IN connector, PR C IN connector and PB IN connector with the color monitor's VIDEO input connector or component input connectors.
- Use the cable supplied with the remote control box to connect the controller's CAMERA CONTROL IN FROM RCB connector with the remote control box's RCB connector.
- Check that the pan/tilt head and camera can be controlled by the controller.

Connections

⑫ When the pan/tilt head is to be controlled by the AW-RP400 pan/tilt head control panel for transmitting SDI signals (and the WV-CB700A remote control box is used to control the camera)

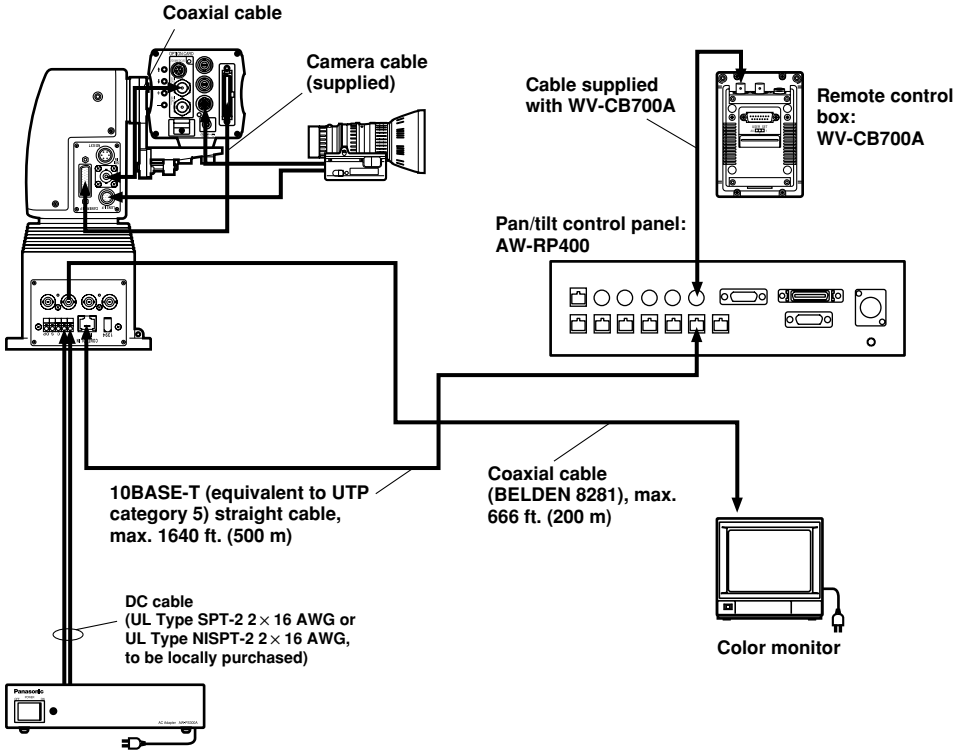

- Use the supplied camera cable to connect the unit with the convertible camera containing the plugged-in SDI card (such as the AW-PB504N).
- Use a coaxial cable to connect the SDI card's SDI OUT connector with the unit's SDI IN connector. Adjust the cable to a length at which the pan/tilt head will move smoothly.
- Set controller selection switch SW1 to the right side (RP501), and select the transmission signal selection setting that supports the SDI card.
- Use a 10BASE-T straight cable (UTP category 5) to connect the unit's CONTROL IN IP/RP connector with the controller's CONTROL OUT TO PAN/TILT HEAD connector.
- Use a coaxial cable to connect the unit's Pr/SDI OUT connector with the color monitor's SDI input connector.
- Use the cable supplied with the remote control box to connect the controller's CAMERA CONTROL IN FROM RCB connector with the remote control box's RCB connector.
- Check that the pan/tilt head and camera can be controlled by the controller.

Connections

⑬ When the camera and pan/tilt head are to be controlled by a personal computer or other such unit

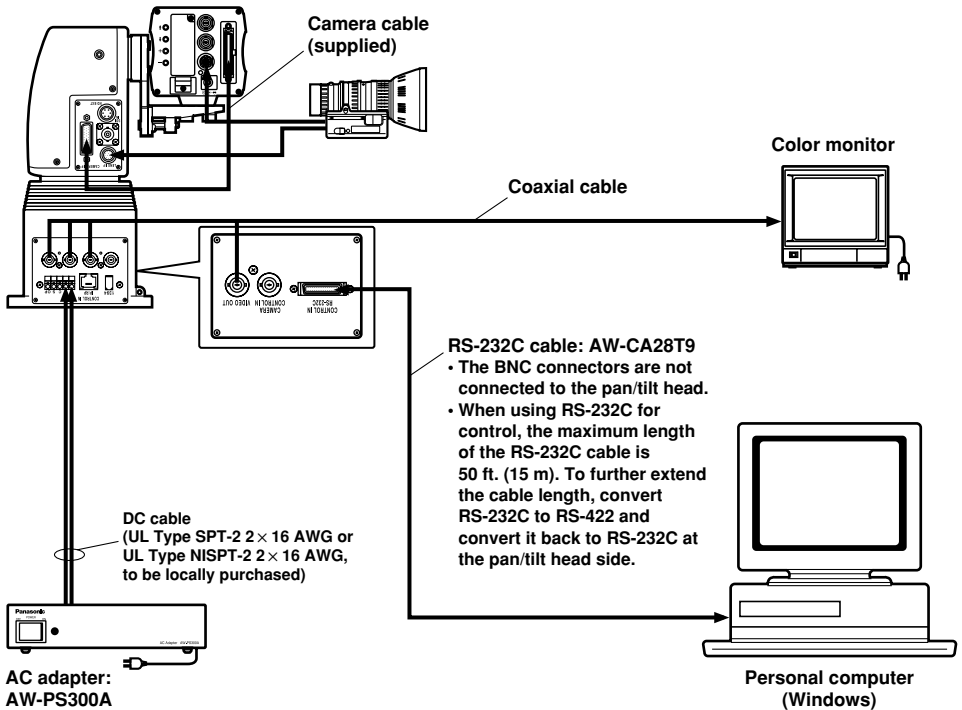

- Use the supplied camera cable to connect the unit with the convertible camera.
- Set controller selection switch SW1 to the right side (RP501), and select the transmission signal selection setting that supports the analog/IEEE1394 card.
- Use the RS-232C cable (AW-CA28T9) to connect the personal computer or other such unit with the unit's CONTROL IN RS-232C connector.
- Use coaxial cables to connect the unit's VIDEO OUT connector or Y OUT connector, Pr/SDI OUT connector and Pb OUT connector with the color monitor's VIDEO input connector or component input connectors.
- Check that the pan/tilt head and camera can be controlled by the controller.
- Transmitting video signals over a long distance requires a separate cable compensation unit.

* When SDI signals are to be transmitted, plug the SDI card (such as the AW-PB504N) into the convertible camera, connect the SDI card's SDI OUT connector with the unit's SDI IN connector using a coaxial cable, and select the transmission signal selection setting that supports the SDI card. Then use another coaxial cable to connect the unit's Pr/SDI OUT connector with the color monitor's SDI input connector.

Connections

⑭ When the camera and pan/tilt head are to be controlled by both the AW-RP501 controller and a personal computer

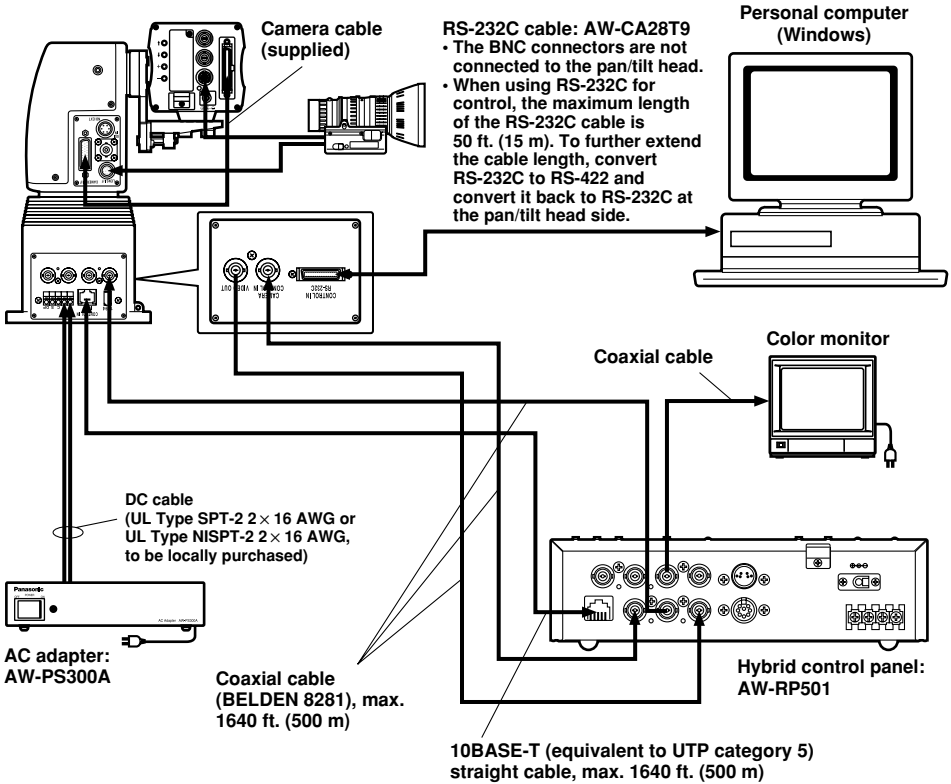

- Use the supplied camera cable to connect the unit with the convertible camera.
 - Set controller selection switch SW1 to the right side (RP501), and select the transmission signal selection setting that supports the analog/IEEE1394 card.
 - Follow connection example ① to connect the unit and AW-RP501 controller. However, when using a personal computer or other such unit to control the camera, leave the unit's CAMERA CONTROL IN connector unconnected.
 - Use the RS-232C cable (AW-CA28T9) to connect the personal computer or other such unit with the unit's CONTROL IN RS-232C connector.
 - Check that the pan/tilt head and camera can be controlled using the controller and personal computer or other such unit. However, the camera can be controlled solely by the controller if the unit's CAMERA CONTROL IN connector and controller's CAMERA CONTROL OUT connector are connected and solely by the personal computer or other such unit if these two connectors are not connected.
- ※ When SDI signals are to be transmitted, plug the SDI card (such as the AW-PB504N) into the convertible camera, connect the SDI card's SDI OUT connector with the unit's SDI IN connector using a coaxial cable, and select the transmission signal selection setting that supports the SDI card. Then use another coaxial cable to connect the unit's Pr/SDI OUT connector with the color monitor's SDI input connector.

Connections

⑮ When the unit is to be connected by a network, and the camera and pan/tilt head are to be controlled by a personal computer

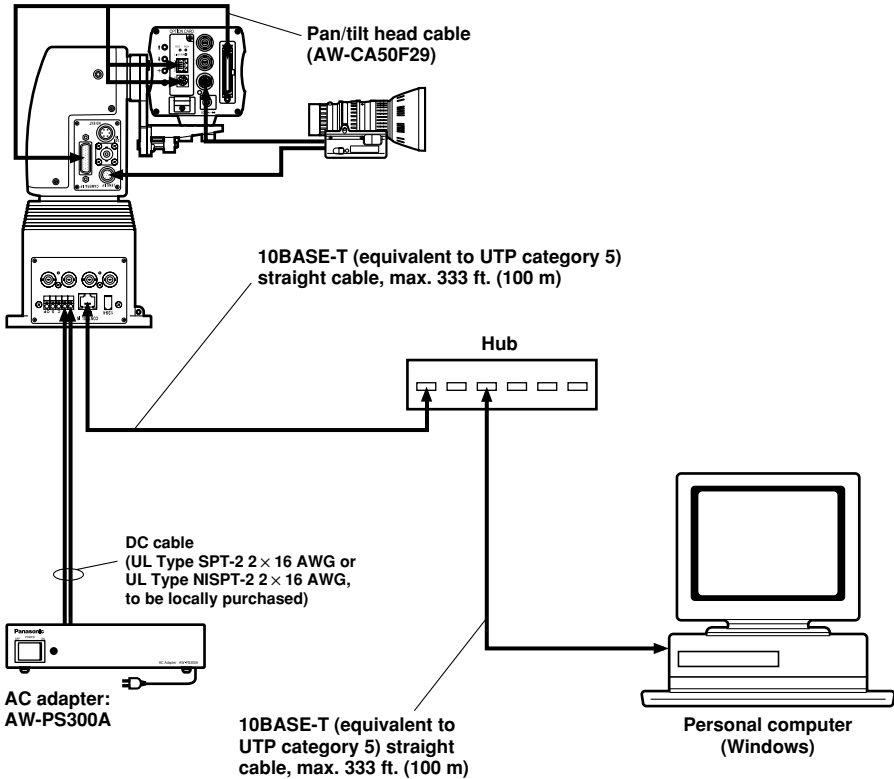

- Use the pan/tilt head cable (AW-CA50F29) to connect the unit with the convertible camera containing the plugged-in WEB card.
- Set controller selection switch SW1 to the right side (RP501), and select the transmission signal selection setting that supports the WEB card.
- Use a 10BASE-T straight cable (UTP category 5) to connect the unit connector with the personal computer (Windows) via the hub.
- Install the browser software (Internet Explorer or Netscape) in the personal computer (Windows).
- Using the browser software, input the IP address which has been set in the WEB card, and check that the pan/tilt head and camera can be controlled by the personal computer.

* For further details, refer to the web card instructions.

Connections

⑩ When the unit is to be connected to a personal computer using the IEEE1394 cable, and the camera and pan/tilt head are to be controlled by the personal computer

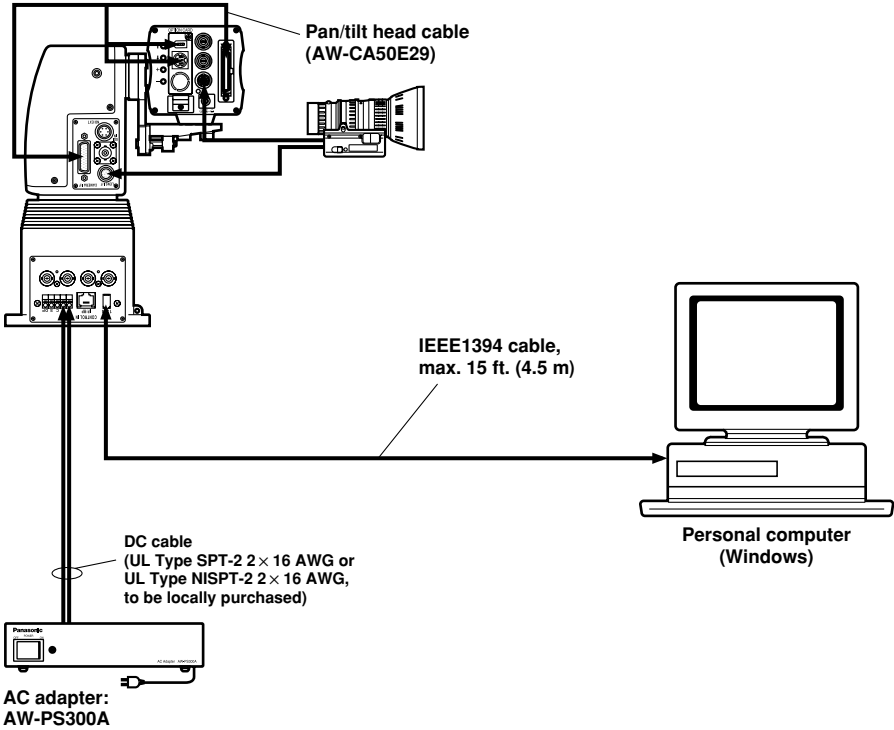

- Use the pan/tilt head cable (AW-CA50E29) to connect the unit with the convertible camera containing the plugged-in IEEE1394 card.
- Set controller selection switch SW1 to the right side (RP501), and select the transmission signal selection setting that supports the analog/IEEE1394 card.
- Use the IEEE1394 cable to connect the unit with the personal computer (Windows).
- Install the driver software and control software from the floppy disk supplied with the IEEE1394 card in the personal computer (Windows).
- Check that the pan/tilt head and camera can be controlled by the personal computer (Windows) using the control software.

※ For further details, refer to the IEEE1394 card instructions.

Limiters

Be absolutely sure to set the limiters (travel range) of the pan/tilt head before use. Depending on where the pan/tilt head system has been installed, obstacles may be present within the travel range with which the camera may come into contact. Contact with any such obstacle by the camera may cause malfunctioning or accidents. In this case, contact can be prevented by setting the limiters directly before any such obstacle.

The controller is used to set the limiters.

The positions of four limiters — namely, the upper, lower, left-most and right-most limits of the travel range — can be set.

Once they have been set, the positions will not be lost even after the power has been turned off.

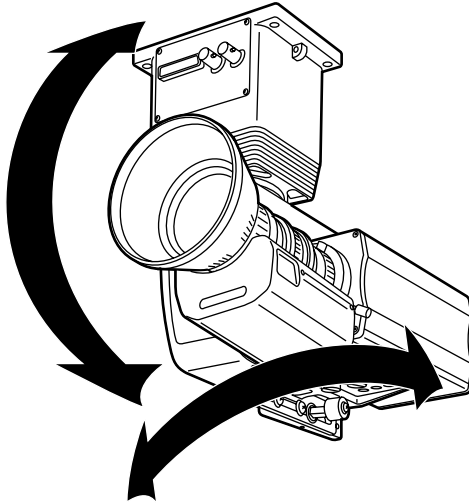

Limiters

■ Setting/releasing the limiters

- For the controller AW-RP301/AW-RP305/AW-RP501/AW-RP505

1. **To set the upper limit position of the travel range:**

Using the controller, tilt the camera to the position which is to serve as the upper limit.

While holding down the MEMORY button on the controller, press PRESET button 2 and PRESET button 3 simultaneously for at least 5 seconds.

The setting is completed as soon as the lamp of the PRESET button 5 comes on.

To release the setting:

While holding down the MEMORY button on the controller, press PRESET button 2 and PRESET button 3 simultaneously for at least 5 seconds.

The setting is released when the lamp of the PRESET button 10 comes on.

2. **To set the lower limit position of the travel range:**

Using the controller, tilt the camera to the position which is to serve as the lower limit.

While holding down the MEMORY button on the controller, press PRESET button 7 and PRESET button 8 simultaneously for at least 5 seconds.

The setting is completed as soon as the lamp of the PRESET button 5 comes on.

To release the setting:

While holding down the MEMORY button on the controller, press PRESET button 7 and PRESET button 8 simultaneously for at least 5 seconds.

The setting is released when the lamp of the PRESET button 10 comes on.

3. **To set the left-most limit position of the travel range:**

Using the controller, tilt the camera to the position which is to serve as the left-most limit.

While holding down the MEMORY button on the controller, press PRESET button 1 and PRESET button 6 simultaneously for at least 5 seconds.

The setting is completed as soon as the lamp of the PRESET button 5 comes on.

To release the setting:

While holding down the MEMORY button on the controller, press PRESET button 1 and PRESET button 6 simultaneously for at least 5 seconds.

The setting is released when the lamp of the PRESET button 10 comes on.

4. **To set the right-most limit position of the travel range:**

Using the controller, tilt the camera to the position which is to serve as the right-most limit.

While holding down the MEMORY button on the controller, press PRESET button 4 and PRESET button 9 simultaneously for at least 5 seconds.

The setting is completed as soon as the lamp of the PRESET button 5 comes on.

To release the setting:

While holding down the MEMORY button on the controller, press PRESET button 4 and PRESET button 9 simultaneously for at least 5 seconds.

The setting is released when the lamp of the PRESET button 10 comes on.

Limiters

- For the controller AW-RP605A

1. **To set the upper limit position of the travel range:**

Using the controller, tilt the camera to the position which is to serve as the upper limit.

While holding down the OK button on the controller, press TRACING/PRESET MEMORY button 47 \uparrow .

The setting is completed as soon as the lamp of the TRACING/PRESET MEMORY button 41 [LIMIT ON] comes on.

To release the setting:

While holding down the OK button on the controller, press TRACING/PRESET MEMORY button 47 \uparrow .

The setting is released when the lamp of the TRACING/PRESET MEMORY button 50 [LIMIT OFF] comes on.

2. **To set the lower limit position of the travel range:**

Using the controller, tilt the camera to the position which is to serve as the lower limit.

While holding down the OK button on the controller, press TRACING/PRESET MEMORY button 46 \downarrow .

The setting is completed as soon as the lamp of the TRACING/PRESET MEMORY button 41 [LIMIT ON] comes on.

To release the setting:

While holding down the OK button on the controller, press TRACING/PRESET MEMORY button 46 \downarrow .

The setting is released when the lamp of the TRACING/PRESET MEMORY button 50 [LIMIT OFF] comes on.

3. **To set the left-most limit position of the travel range:**

Using the controller, tilt the camera to the position which is to serve as the left-most limit.

While holding down the OK button on the controller, press TRACING/PRESET MEMORY button 44 \leftarrow .

The setting is completed as soon as the lamp of the TRACING/PRESET MEMORY button 41 [LIMIT ON] comes on.

To release the setting:

While holding down the OK button on the controller, press TRACING/PRESET MEMORY button 44 \leftarrow .

The setting is released when the lamp of the TRACING/PRESET MEMORY button 50 [LIMIT OFF] comes on.

4. **To set the right-most limit position of the travel range:**

Using the controller, tilt the camera to the position which is to serve as the right-most limit.

While holding down the OK button on the controller, press TRACING/PRESET MEMORY button 45 \rightarrow .

The setting is completed as soon as the lamp of the TRACING/PRESET MEMORY button 41 [LIMIT ON] comes on.

To release the setting:

While holding down the OK button on the controller, press TRACING/PRESET MEMORY button 45 \rightarrow .

The setting is released when the lamp of the TRACING/PRESET MEMORY button 50 [LIMIT OFF] comes on.

Limiters

• For the controller AW-RP400

1. **To set the upper limit position of the travel range:**

Using the controller, tilt the camera to the position which is to serve as the upper limit.

While holding down the MENU/LIMIT button on the controller, press PRESET MEMORY button 15 ↑.

The setting is completed as soon as the lamp of the PRESET MEMORY button 45 comes on.

To release the setting:

While holding down the MENU/LIMIT button on the controller, press PRESET MEMORY button 15 ↑.

The setting is released when the lamp of the PRESET MEMORY button 50 comes on.

2. **To set the lower limit position of the travel range:**

Using the controller, tilt the camera to the position which is to serve as the lower limit.

While holding down the MENU/LIMIT button on the controller, press PRESET MEMORY button 20 ↓.

The setting is completed as soon as the lamp of the PRESET MEMORY button 45 comes on.

To release the setting:

While holding down the MENU/LIMIT button on the controller, press PRESET MEMORY button 20 ↓.

The setting is released when the lamp of the PRESET MEMORY button 50 comes on.

3. **To set the left-most limit position of the travel range:**

Using the controller, tilt the camera to the position which is to serve as the left-most limit.

While holding down the MENU/LIMIT button on the controller, press PRESET MEMORY button 5 ←.

The setting is completed as soon as the lamp of the PRESET MEMORY button 45 comes on.

To release the setting:

While holding down the MENU/LIMIT button on the controller, press PRESET MEMORY button 5 ←.

The setting is released when the lamp of the PRESET MEMORY button 50 comes on.

4. **To set the right-most limit position of the travel range:**

Using the controller, tilt the camera to the position which is to serve as the right-most limit.

While holding down the MENU/LIMIT button on the controller, press PRESET MEMORY button 10 →.

The setting is completed as soon as the lamp of the PRESET MEMORY button 45 comes on.

To release the setting:

While holding down the MENU/LIMIT button on the controller, press PRESET MEMORY button 10 →.

The setting is released when the lamp of the PRESET MEMORY button 50 comes on.

Replacement of consumable parts

■ Replacing the battery

The battery lasts for about 5 years. The pan/tilt head stores the preset positions, limiter positions and other data in its memory. Although this data is retained even after the power has been turned off, it will be lost when the power is turned off once the battery has reached the end of its service life.

Replace the battery once it has lost its effectiveness. (The pan/tilt head uses a CR2032 manganese dioxide-lithium battery.)

Removing the battery

1. Remove the four cover screws, and remove the head cover.
2. Press the battery in the direction shown by the arrow in the figure, and slide it.
3. From this position, lift the battery from the bottom of its arrow area.
4. Once the arrow part of the battery has been removed from the battery holder, pull the battery forward and out to remove it completely.

Installing the new battery

1. With the “+” pole of the new battery turned toward you, insert the end into the battery holder from the direction of the arrow.
2. While pushing the battery in the direction of the arrow, push it right into the holder.

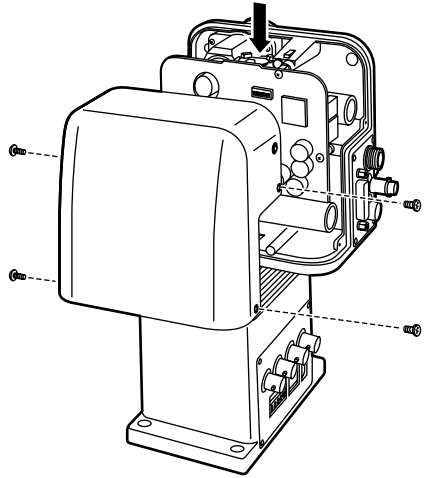

■ Replacing the motor

Replace the motor if it is not working properly.

- Consult your dealer on how to replace the motor.

■ Replacing the gear

Replace the gear when its preset stop accuracy has deteriorated.

- Consult your dealer on how to replace the gear.

The motor and gear are consumable parts. They must be replaced at regular intervals.

Specifications

Power supply:	DC +12 V (connector)
Power consumption:	DC +12 V 3 A (camera power included), DC +12 V 1.3 A (pan/tilt head only)

 indicates safety information.

Genlock input: Black burst or composite video (BNC connector)

Camera video output: Video: 75 Ω (BNC connector)
Y: 75 Ω (BNC connector)
Pr: 75 Ω (BNC connector) (Switchable to SDI)
Pb: 75 Ω (BNC connector)
SDI: BNC connector (Switchable to Pr)

Camera / pan/tilt head control:

- **Controller (AW-RP301/AW-RP305)**
Pan/tilt head control: RS-422 (RJ-45, modular jack)
- **Controller (AW-RP501/AW-RP505)**
Pan/tilt head control: RS-422 (RJ-45, modular jack)
Camera control: Interactive serial communication (BNC connector)
- **Controller (AW-RP605A)**
Camera / Pan/tilt head control: RS-422 (RJ-45, modular jack)
- **Controller (AW-RP400)**
Camera / Pan/tilt head control: RS-485 (RJ-45, modular jack)
- **Controller (Personal computer, etc.)**
Camera / Pan/tilt head control: RS-232C (28 pin, half pitch connector)

Lamp control: Control signals (connector)

Option control: Control signals (connector)

Maximum cable length:

- **Controller (AW-RP301/AW-RP305/AW-RP501/AW-RP505/AW-RP400)**
500 m (with BELDEN 8281 coaxial cable, 10BASE-T straight cable equivalent to UTP category 5)
- **Controller (AW-RP605A)**
1000 m (with BELDEN 8281 coaxial cable, 10BASE-T straight cable equivalent to UTP category 5)
When the SDI signal is transmitted: 200 m with BELDEN 8281 coaxial cable

Maximum load capacity: 8.8 lb (4 kg)

Allowable operating temperature:

14°F to 113°F (–10°C to +45°C)

Specifications

Allowable operating humidity:

Max. 90%

Dimensions (W × H × D): 5 1/8" × 9 5/8" × 7 9/16" (130 × 244 × 192 mm)

Weight: Approx. 7.7 lb (3.5 kg)

Finish: AV ivory paint (color resembling Munsell 7.9Y 6.8/0.8)

■ Functions/performance

Tilt range: 190 degrees (approx. ±95 degrees)
Tilt range may be subject to restrictions depending on the mounted camera cable, lens, etc.

Panning range: 300 degrees (approx. ±150 degrees)

Maximum operating speed: 30 degrees/sec. for panning, 25 degrees/sec. for tilting

Repeatability: Less than ±3'

Noise level: Less than NC30

Weight and Dimensions indicated above are approximate.
Specifications are subject to change without notice.

Panasonic®

PANASONIC BROADCAST & TELEVISION SYSTEMS COMPANY
UNIT COMPANY OF PANASONIC CORPORATION OF NORTH AMERICA

Executive Office:

One Panasonic Way 4E-7, Secaucus, NJ 07094 (201) 348-7000

EASTERN ZONE:

One Panasonic Way 4E-7, Secaucus, NJ 07094 (201) 348-7621

Southeast Region:

1225 Northbrook Parkway, Ste 1-160, Suwanee, GA 30024 (770) 338-6835

Central Region:

1707 N Randall Road E1-C-1, Elgin, IL 60123 (847) 468-5200

WESTERN ZONE:

3330 Cahuenga Blvd W., Los Angeles, CA 90068 (323) 436-3500

Government Marketing Department:

52 West Gude Drive, Rockville, MD 20850 (301) 738-3840

Broadcast PARTS INFORMATION & ORDERING:

9:00 a.m. – 5:00 p.m. (EST) (800) 334-4881/24 Hr. Fax (800) 334-4880

Emergency after hour parts orders (800) 334-4881

TECHNICAL SUPPORT:

Emergency 24 Hour Service (800) 222-0741

Panasonic Canada Inc.

5770 Ambler Drive, Mississauga, Ontario L4W 2T3 (905) 624-5010

Panasonic de Mexico S.A. de C.V.

Av angel Urraza Num. 1209 Col. de Valle 03100 Mexico, D.F. (52) 1 951 2127

Panasonic Puerto Rico Inc.

San Gabriel Industrial Park, 65th Infantry Ave., Km. 9.5, Carolina, Puerto Rico 00630
(787) 750-4300

© 2005 Matsushita Electric Industrial Co., Ltd. All rights reserved.

