

HP ProLiant ML350 Generation 5 Server User Guide



Part Number 405047-003
September 2007 (Third Edition)

© Copyright 2006, 2007 Hewlett-Packard Development Company, L.P.

The information contained herein is subject to change without notice. The only warranties for HP products and services are set forth in the express warranty statements accompanying such products and services. Nothing herein should be construed as constituting an additional warranty. HP shall not be liable for technical or editorial errors or omissions contained herein.

Microsoft, Windows, and Windows NT are U.S. registered trademarks of Microsoft Corporation. Windows Server 2003 is a trademark of Microsoft Corporation.

Audience assumptions

This document is for the person who installs, administers, and troubleshoots servers and storage systems. HP assumes you are qualified in the servicing of computer equipment and trained in recognizing hazards in products with hazardous energy levels.

Contents

Component identification	7
Front panel components	7
Front panel LEDs and buttons	8
Rear panel components	9
Rear panel LEDs and buttons	10
System board components	11
NMI jumper	12
System maintenance switch	12
System board LEDs	13
System LEDs and internal health LED combinations	14
SAS and SATA hard drive LEDs	15
SAS and SATA hard drive LED combinations	15
Operations	17
Power up the server	17
Power down the server	17
Extend the server from the rack	17
Remove the server from the rack	18
Access the server rear panel (rack model)	18
Open or remove the tower bezel	18
Remove the access panel	19
Install the access panel	20
Setup	21
Optional installation services	21
Optimum environment	21
Space and airflow requirements	21
Temperature requirements	22
Power requirements	23
Electrical grounding requirements	23
Rack planning resources	24
Rack warnings	24
Contents of the tower server shipping carton	24
Contents of the rack server shipping carton	25
Installing hardware options	25
Setting up a tower server	25
Installing the server into the rack	26
Powering up and configuring the server	27
Installing the operating system	28
Registering the server	28
Hardware options installation	29
Introduction	29
Processor option	29
Memory options	36
Memory configurations	36
Advanced ECC memory	36

Online spare memory configuration	37
Installing FBDIMMs	37
Hard drive blank	38
SATA or SAS hard drive option	39
Removable media device options	40
Accessing the removable media cage	40
Identifying guide screws	42
Installing a half-height or full-height media device	42
Installing the full-height media device shipping screw	44
Installing a diskette drive	45
Redundant hot-plug power supply option	46
Expansion board options	48
Removing the expansion slot cover	48
Installing an expansion board	49
Parallel and second serial connector option	51
PCI-X expansion cage option	52
Redundant fan assembly option	59
Battery-backed write cache option	60
Tower-to-rack conversion option	62
Cabling	65
Optional SATA or SAS cabling	65
Standard SATA hard drive cabling	65
Optical drive cabling	65
Optional ATA or ATAPI device cabling	66
Configuration and utilities	67
Configuration tools	67
SmartStart software	67
ROM-Based Setup Utility	68
Array Configuration Utility	69
Option ROM Configuration for Arrays	70
HP ProLiant Essentials Rapid Deployment Pack	70
Re-entering the server serial number and product ID	70
Management tools	71
Automatic Server Recovery	71
ROMPaq utility	71
Integrated Lights-Out 2 technology	71
System Online ROM flash component utility	72
Erase Utility	72
Management Agents	72
HP Systems Insight Manager	73
Redundant ROM support	73
USB support	74
Diagnostic tools	74
Array Diagnostic Utility	74
HP Insight Diagnostics	75
Integrated Management Log	75
Keeping the system current	75
Drivers	75
ProLiant Support Packs	76
Operating system version support	76
Change control and proactive notification	76
Care Pack	76

Troubleshooting	77
Troubleshooting resources	77
Pre-diagnostic steps	77
Important safety information	77
Symptom information	79
Prepare the server for diagnosis	80
Loose connections	80
Service notifications	81
Troubleshooting flowcharts	81
Start diagnosis flowchart	81
General diagnosis flowchart	82
Server power-on problems flowchart	84
POST problems flowchart	87
OS boot problems flowchart	88
Server fault indications flowchart	90
POST error messages and beep codes	92
Introduction to POST error messages	92
Power Supply Solution Not Fully Redundant	93
207-Invalid Memory Configuration - DIMMs must be installed in pairs or sequentially	93
Battery replacement	94
Regulatory compliance notices	96
Regulatory compliance identification numbers	96
Federal Communications Commission notice	96
FCC rating label	96
Class A equipment	96
Class B equipment	96
Declaration of conformity for products marked with the FCC logo, United States only	97
Modifications	97
Cables	97
Canadian notice (Avis Canadien)	98
European Union regulatory notice	98
Japanese notice	99
BSMI notice	99
Korean notice	99
Laser compliance	100
Battery replacement notice	100
Taiwan battery recycling notice	100
Power cord statement for Japan	101
Electrostatic discharge	102
Preventing electrostatic discharge	102
Grounding methods to prevent electrostatic discharge	102
Server specifications	103
Environmental specifications	103
Server specifications	103
Technical support	105
Related documents	105
Before you contact HP	105
HP contact information	105
Customer Self Repair	106

Acronyms and abbreviations.....	113
Index.....	116

Component identification

Front panel components

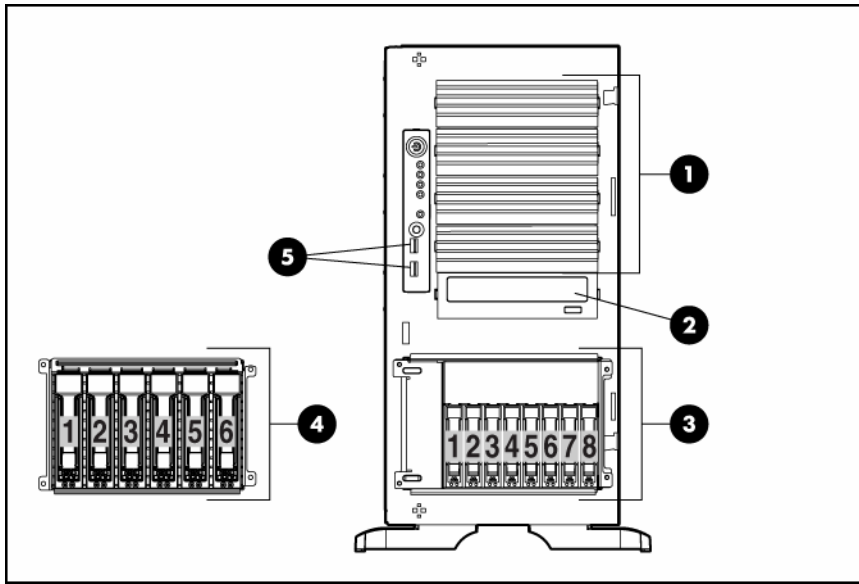

Item	Description
1	Removable media bays (4)
2	CD-ROM drive
3	Hot-plug hard drive bays (8-bay drive cage model)
4	Hot-plug hard drive bays (6-bay drive cage model)
5	USB connectors (2)

Front panel LEDs and buttons

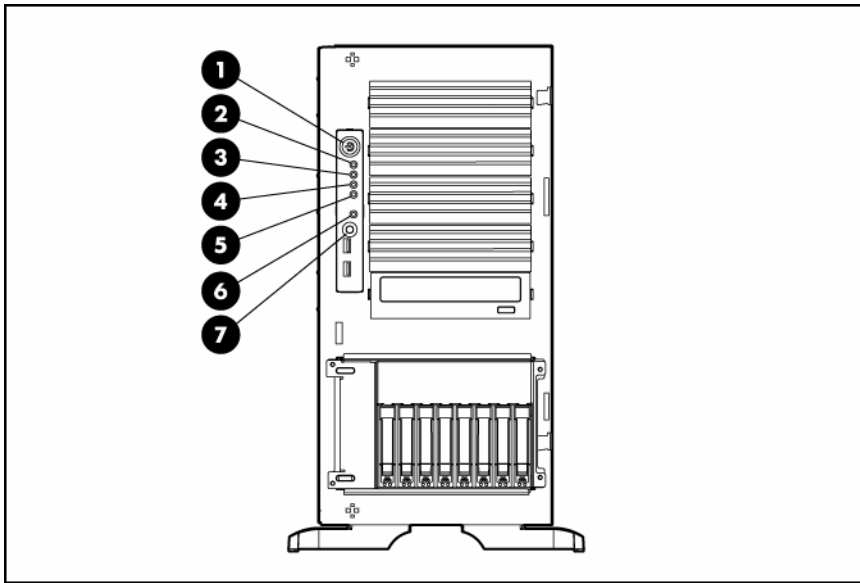

Item	Description	Status
1	Power On/Standby button	—
2	System power LED	Green = Power on Amber = System shut down, but power still applied Off = No power
3	Internal health LED	Green = Normal Amber = System degraded. To identify the component in a degraded state, refer to system board LEDs (on page 13). Red = System critical. To identify the component in a critical state, refer to system board LEDs (on page 13). Off = Normal (when in standby mode)
4	External health LED (power supply)	Green = Normal Amber = Power redundancy failure Red = Critical power supply failure
5	NIC 1 activity LED	Green = Network link Flashing = Network link and activity Off = No link to network. If power is off, view status on the rear panel RJ-45 LEDs.
6	UID LED	Blue = Activated Flashing = System remotely managed Off = Deactivated
7	UID button	—

Rear panel components

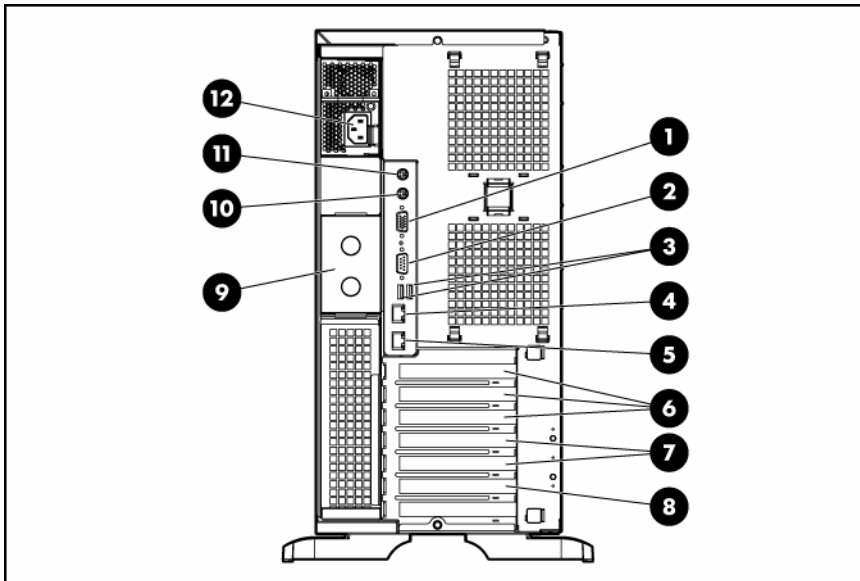

Item	Description
1	Video connector
2	Serial connector
3	USB connectors (2)
4	RJ-45 Ethernet connector (iLO 2 management)
5	RJ-45 Ethernet connector (data)
6	PCI Express x8 slots (x4 routed)
7	PCI-X slots (100-MHz)
8	PCI-X slot (133-MHz)
9	Optional redundant hot-plug power supply bay
10	Mouse connector
11	Keyboard connector
12	Power cord connector

Rear panel LEDs and buttons

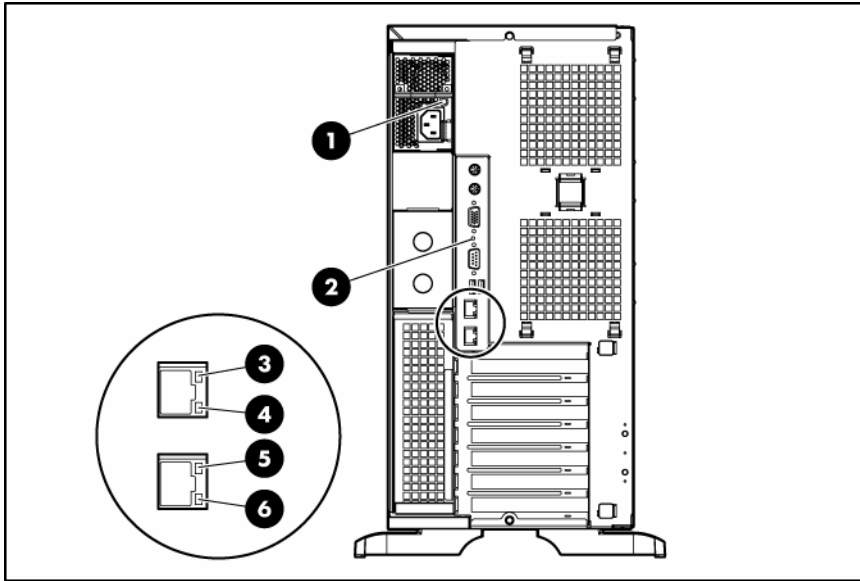

Item	Description	Status
1	Power supply LED	Green = Power supply is on and functioning Off = No power or inadequate power supply
2	UID LED and button	Blue = Activated Flashing blue = Remote inquiry Off = Deactivated
3	iLO 2 activity LED	Green or flashing = Network activity Off = No network activity
4	iLO 2 link LED	Green = Linked to network Off = Not linked to network
5	10/100/1000 NIC activity LED	Green or flashing = Network activity Off = No network activity
6	10/100/1000 NIC link LED	Green = Linked to network Off = Not linked to network

System board components

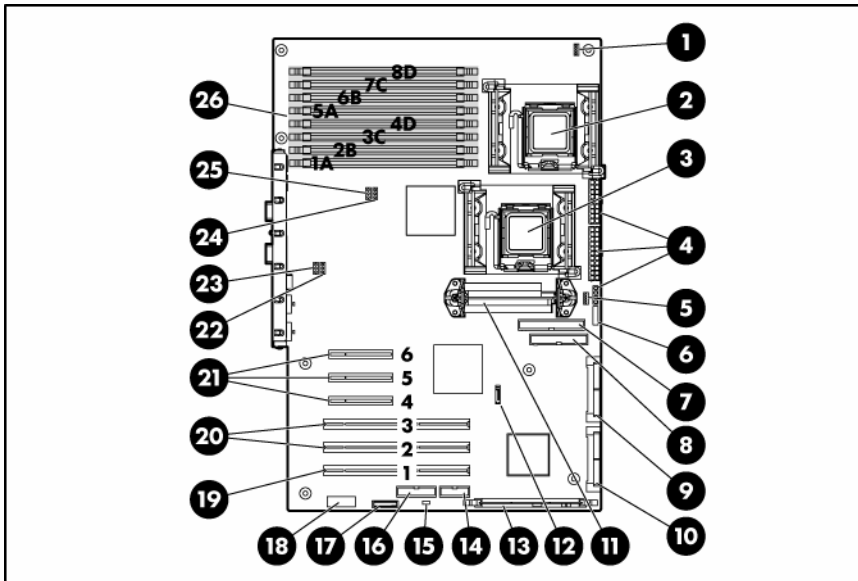

NOTE: PPM 1 is embedded in the system board.

Item	Description
1	Processor 1 heatsink fan connector
2	Processor socket 1
3	Processor socket 2
4	Power supply connectors
5	Processor 2 heatsink fan connector
6	Power button/LED connector
7	PATA connector
8	Diskette drive connector
9	SAS/SATA connector (drives 1-4)
10	SAS/SATA connector (drives 5-8)
11	PPM 2 slot
12	SATA optical connector (select models only)
13	HP Smart Array E200i memory connector
14	Optional serial port connector
15	NMI jumper
16	Optional parallel port connector
17	System battery
18	System maintenance switch
19	PCI-X slot 1 (133-MHz)
20	PCI-X slots 2-3 (100-MHz)
21	PCI Express x8 slots 4-6 (x4 routed)

Item	Description
22	Optional redundant system fan 4 connector
23	System fan 2 connector
24	Optional redundant system fan 3 connector
25	System fan 1 connector
26	FBDIMM slots

NMI jumper

The NMI jumper allows administrators to perform a memory dump before performing a hard reset. Crash dump analysis is an essential part of eliminating reliability problems, such as hangs or crashes in operating systems, device drivers, and applications. Many crashes freeze a system, requiring you to do a hard reset. Resetting the system erases any information that would support root cause analysis.

Systems running Microsoft® Windows® operating systems experience a blue screen trap when the operating system crashes. When this happens, Microsoft® recommends that system administrators perform an NMI event by pressing a dump switch. The NMI event enables a hung system to become responsive again.

System maintenance switch

Position	Default	Function
S1	iLO 2 security	Off = iLO 2 security is enabled On = iLO 2 security is disabled
S2	Off	Off = System configuration can be changed. On = System configuration is locked.
S3	Off	Reserved
S4	Off	Reserved
S5	Off	Off = Power-on password is enabled. On = Power-on password is disabled.
S6	Off	Off = No function On = Clear NVRAM
S7	—	Reserved
S8	—	Reserved

When the system maintenance switch position 6 is set to the On position, the system is prepared to erase all system configuration settings from both CMOS and NVRAM.



CAUTION: Clearing CMOS and/or NVRAM deletes configuration information. Be sure to properly configure the server or data loss could occur.

System board LEDs

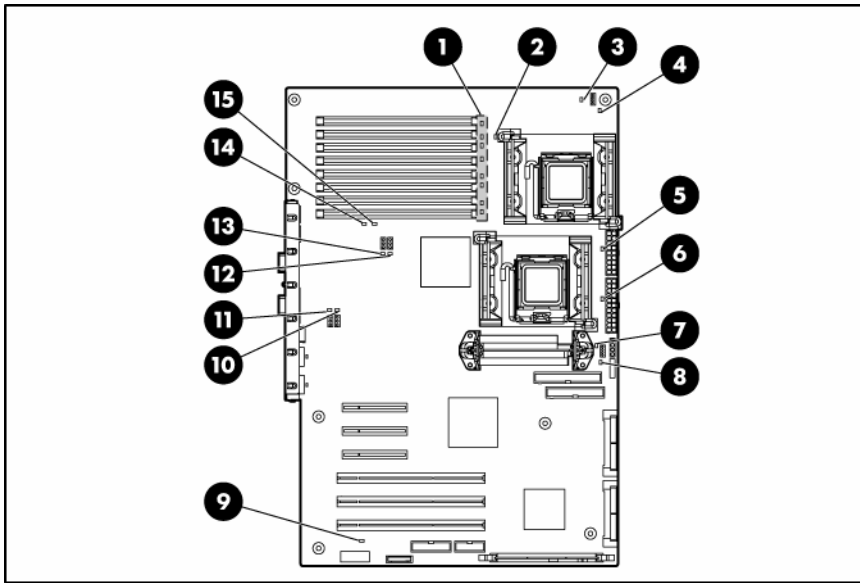

Item	Description	Status
1	FBDIMM 1-8	Amber = FBDIMM failed Off = FBDIMM functioning
2	Processor 1	Amber = Processor 1 failed Off = Processor 1 functioning
3	Processor 1 fan failure (fan 5)	Amber = Fan is not installed or has failed Off = Processor fan is functioning
4	PPM 1 (embedded)	Amber = PPM 1 failed Off = PPM 1 functioning
5	Processor 2	Amber = Processor 2 failed Off = Processor 2 functioning
6	AC power	Green = Power supply is on and functioning Off = No AC power or failed power supply
7	Processor 2 fan failure (fan 6)	Amber = Fan is not installed or has failed Off = Processor fan is functioning
8	PPM 2	Amber = PPM 2 failed Off = PPM 2 functioning
9	Temperature threshold	Amber = System temperature threshold exceeded Off = Normal operation
10	Optional redundant system fan 4	Amber = Redundant fan has failed Off = Redundant fan is functioning
11	System fan 3	Amber = Fan is not installed or has failed Off = Rear fan is functioning

Item	Description	Status
12	Optional redundant system fan 2	Amber = Redundant fan has failed Off = Redundant fan is functioning
13	System fan 1	Amber = Fan is not installed or has failed Off = Rear fan is functioning
14	Online spare memory	Amber = Online spare memory is in use due to memory failover Off = Normal operation
15	Memory mode	Green = System is in online spare memory mode Off = Normal operation

System LEDs and internal health LED combinations

When the internal health LED on the front panel illuminates either amber or red, the server is experiencing a health event. Combinations of illuminated system LEDs and the internal health LED indicate system status.

The front panel health LEDs indicate only the current hardware status. In some situations, HP SIM may report server status differently than the health LEDs because the software tracks more system attributes.

System LED and color	Internal health LED color	Status
Processor failure, socket X (amber)	Red	One or more of the following conditions may exist: <ul style="list-style-type: none"> • Processor in socket X has failed. • Processor in socket X failed over to the second processor. • Processor X is not installed in the socket. • Processor X is not supported. • Processor heatsink is not attached properly.
	Amber	Processor in socket X is in a pre-failure condition.
Processor failure, both sockets (amber)	Red	Processor types are mismatched.
PPM failure (amber)	Red	<ul style="list-style-type: none"> • PPM has failed. • PPM is not installed, but the corresponding processor is installed.
FBDIMM failure, slot X (amber)	Red	<ul style="list-style-type: none"> • FBDIMM in slot X has failed. • FBDIMM in slot X is an unsupported type, and no valid memory exists in another bank.
	Amber	<ul style="list-style-type: none"> • FBDIMM in slot X has reached single-bit correctable error threshold. • FBDIMM in slot X is in a pre-failure condition. • FBDIMM in slot X is an unsupported type, but valid memory exists in another bank.

System LED and color	Internal health LED color	Status
Overtemperature (amber)	Red	<ul style="list-style-type: none"> The Health Driver has detected a cautionary temperature level. The server has detected a hardware critical temperature level.
Fan (amber)	Red	The minimum fan requirements are not being met. Fan has failed.
	Amber	A fan has failed but still meets the minimum fan requirements (with redundant fan option only).

SAS and SATA hard drive LEDs

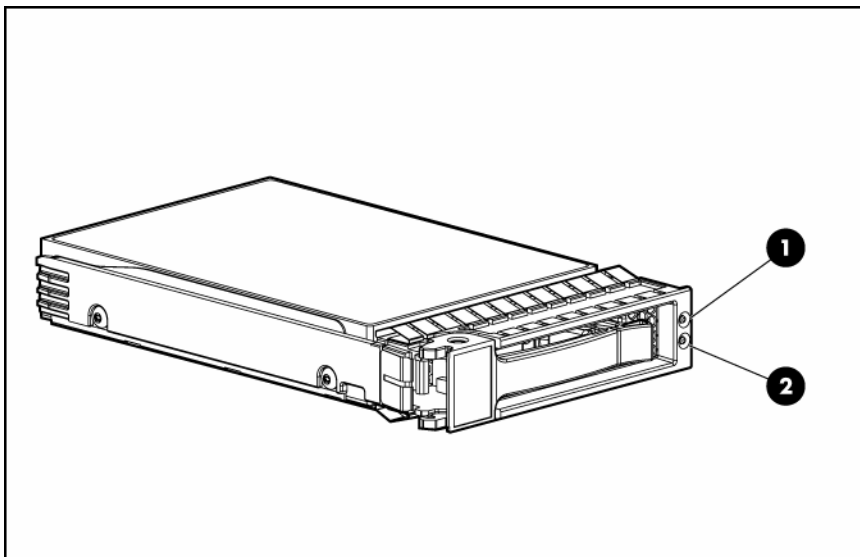

Item	Description
1	Fault/UID LED (amber/blue)
2	Online LED (green)

SAS and SATA hard drive LED combinations

Online/activity LED (green)	Fault/UID LED (amber/blue)	Interpretation
On, off, or flashing	Alternating amber and blue	The drive has failed, or a predictive failure alert has been received for this drive; it also has been selected by a management application.
On, off, or flashing	Steadily blue	The drive is operating normally, and it has been selected by a management application.
On	Amber, flashing regularly (1 Hz)	A predictive failure alert has been received for this drive. Replace the drive as soon as possible.
On	Off	The drive is online, but it is not active currently.

Online/activity LED (green)	Fault/UID LED (amber/blue)	Interpretation
Flashing regularly (1 Hz)	Amber, flashing regularly (1 Hz)	<p>Do not remove the drive. Removing a drive may terminate the current operation and cause data loss.</p> <p>The drive is part of an array that is undergoing capacity expansion or stripe migration, but a predictive failure alert has been received for this drive. To minimize the risk of data loss, do not replace the drive until the expansion or migration is complete.</p>
Flashing regularly (1 Hz)	Off	<p>Do not remove the drive. Removing a drive may terminate the current operation and cause data loss.</p> <p>The drive is rebuilding, or it is part of an array that is undergoing capacity expansion or stripe migration.</p>
Flashing irregularly	Amber, flashing regularly (1 Hz)	The drive is active, but a predictive failure alert has been received for this drive. Replace the drive as soon as possible.
Flashing irregularly	Off	The drive is active, and it is operating normally.
Off	Steadily amber	A critical fault condition has been identified for this drive, and the controller has placed it offline. Replace the drive as soon as possible.
Off	Amber, flashing regularly (1 Hz)	A predictive failure alert has been received for this drive. Replace the drive as soon as possible.
Off	Off	The drive is offline, a spare, or not configured as part of an array.

Operations

Power up the server

To power up the server, press the Power On/Standby button.

Power down the server



WARNING: To reduce the risk of personal injury, electric shock, or damage to the equipment, remove the power cord to remove power from the server. The front panel Power On/Standby button does not completely shut off system power. Portions of the power supply and some internal circuitry remain active until AC power is removed.



IMPORTANT: If installing a hot-plug device, it is not necessary to power down the server.

1. Back up the server data.
2. Shut down the operating system as directed by the operating system documentation.
3. If the server is installed in a rack, press the UID LED button on the front panel. Blue LEDs illuminate on the front and rear panels of the server.
4. Press the Power On/Standby button to place the server in standby mode. When the server activates standby power mode, the system power LED changes to amber.
5. If the server is installed in a rack, locate the server by identifying the illuminated rear UID LED button.
6. Disconnect the power cords.

The system is now without power.

Extend the server from the rack

1. Pull down the quick-release levers on each side of the server to release the server from the rack.



IMPORTANT: If the server is installed in a telco rack, remove the server from the rack to access internal components.

2. Extend the server on the rack rails until the server rail-release latches engage.



WARNING: To reduce the risk of personal injury or equipment damage, be sure that the rack is adequately stabilized before extending a component from the rack.



WARNING: To reduce the risk of personal injury, be careful when pressing the server rail-release latches and sliding the server into the rack. The sliding rails could pinch your fingers.

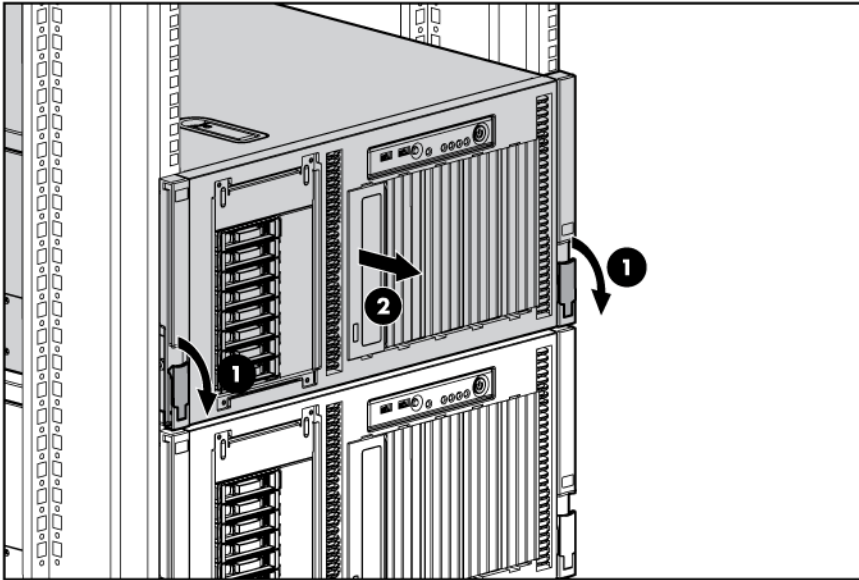

3. After performing the installation or maintenance procedure, press the rail-release latches and slide the server back into the rack.

Remove the server from the rack

To remove the server from an HP, telco, or third-party rack:

1. Power down the server (on page 17).
2. Disconnect the cabling.
3. Extend the server from the rack (on page 17). Reverse the server installation steps in the documentation that ships with the rack-mounting option.
4. Remove the server from the rack.
5. Place the server on a sturdy, level surface.

Access the server rear panel (rack model)

If the procedure requires accessing the server rear panel, unlock the cable management arm and swing the arm away from the server. For information on unlocking the cable management arm, refer to the installation instructions that ship with the 3-7U Quick Deploy Rail System.

Open or remove the tower bezel

This server has a removable bezel that must be unlocked and opened before accessing the front panel components. The bezel should be kept closed during normal server operations.

Use the key provided with the server to unlock the bezel with a clockwise turn.

If necessary, remove the bezel.



CAUTION: To avoid breaking the bezel, remove the bezel before placing the server on its side.

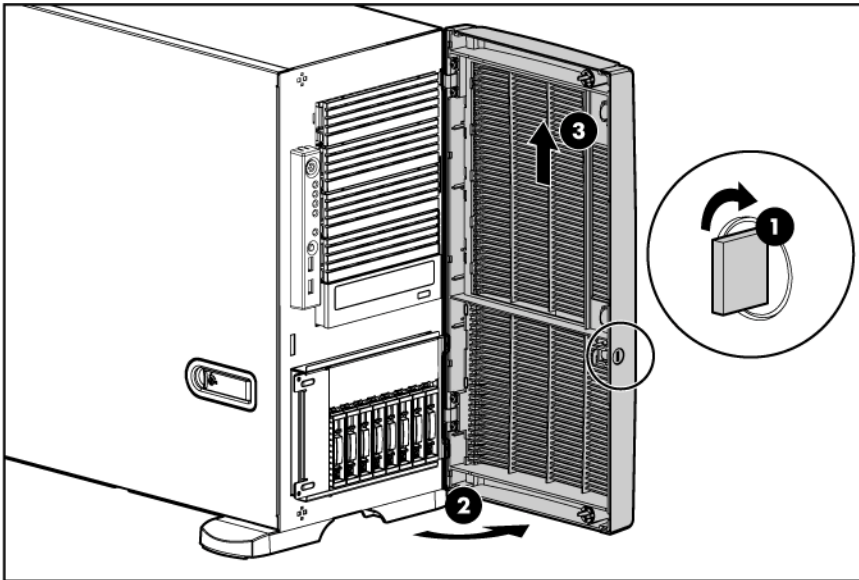

For operations involving removable media bay access, the media bay panel can be removed from the bezel.

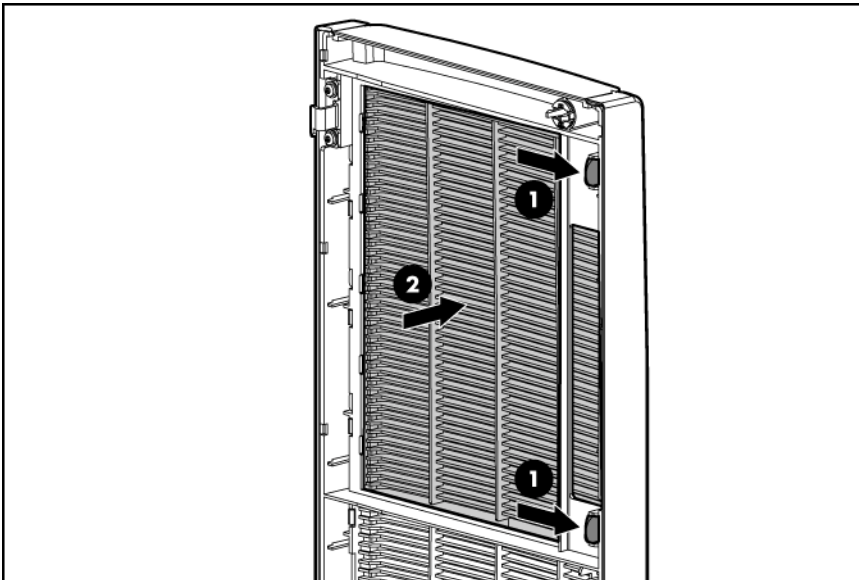

Remove the access panel

1. Release the access panel latch.
2. Slide the access panel back about 1.5 cm (0.5 in).
3. Lift and remove the access panel.

NOTE: Turn the access panel over to locate the hood labels. These labels provide information on installing various options, flexible memory configurations, LED status indicators, and switch settings.

Install the access panel

1. Place the access panel on top of the server, allowing it to extend past the rear of the server approximately 1.5 cm (0.5 in).
2. Slide the access panel forward until it clicks into place, and close the access panel latch.

Setup

Optional installation services

Delivered by experienced, certified engineers, HP Care Pack services help you keep your servers up and running with support packages tailored specifically for HP ProLiant systems. HP Care Packs let you integrate both hardware and software support into a single package. A number of service level options are available to meet your needs.

HP Care Pack Services offer upgraded service levels to expand your standard product warranty with easy-to-buy, easy-to-use support packages that help you make the most of your server investments. Some of the Care Pack services are:

- Hardware support
 - 6-Hour Call-to-Repair
 - 4-Hour 24x7 Same Day
 - 4-Hour Same Business Day
- Software support
 - Microsoft®
 - Linux
 - HP ProLiant Essentials (HP SIM and RDP)
 - VMWare
- Integrated hardware and software support
 - Critical Service
 - Proactive 24
 - Support Plus
 - Support Plus 24
- Startup and implementation services for both hardware and software

For more information on Care Packs, refer to the HP website (http://www.hp.com/hps/carepack/servers/cp_proliant.html).

Optimum environment

When installing the server, select a location that meets the environmental standards described in this section.

Space and airflow requirements

Tower server

In a tower configuration, leave at least a 7.6-cm (3-in) clearance space at the front and back of the server for proper ventilation.

Rack server

To allow for servicing and adequate airflow, observe the following space and airflow requirements when deciding where to install a rack:

- Leave a minimum clearance of 63.5 cm (25 in) in front of the rack.
- Leave a minimum clearance of 76.2 cm (30 in) behind the rack.
- Leave a minimum clearance of 121.9 cm (48 in) from the back of the rack to the back of another rack or row of racks.

HP servers draw in cool air through the front door and expel warm air through the rear door. Therefore, the front and rear rack doors must be adequately ventilated to allow ambient room air to enter the cabinet, and the rear door must be adequately ventilated to allow the warm air to escape from the cabinet.

 **CAUTION:** To prevent improper cooling and damage to the equipment, do not block the ventilation openings.

When vertical space in the rack is not filled by a server or rack component, the gaps between the components cause changes in airflow through the rack and across the servers. Cover all gaps with blanking panels to maintain proper airflow.

 **CAUTION:** Always use blanking panels to fill empty vertical spaces in the rack. This arrangement ensures proper airflow. Using a rack without blanking panels results in improper cooling that can lead to thermal damage.

The 9000 and 10000 Series Racks provide proper server cooling from flow-through perforations in the front and rear doors that provide 64 percent open area for ventilation.

 **CAUTION:** When using a Compaq branded 7000 Series rack, you must install the high airflow rack door insert [P/N 327281-B21 (42U) or P/N 157847-B21 (22U)] to provide proper front-to-back airflow and cooling.

 **CAUTION:** If a third-party rack is used, observe the following additional requirements to ensure adequate airflow and to prevent damage to the equipment:

- Front and rear doors—If the 42U rack includes closing front and rear doors, you must allow 5,350 sq cm (830 sq in) of holes evenly distributed from top to bottom to permit adequate airflow (equivalent to the required 64 percent open area for ventilation).
 - Side—The clearance between the installed rack component and the side panels of the rack must be a minimum of 7 cm (2.75 in).
-

Temperature requirements

To ensure continued safe and reliable equipment operation, install or position the system in a well-ventilated, climate-controlled environment.

The maximum recommended ambient operating temperature (TMRA) for most server products is 35°C (95°F). The temperature in the room where the rack is located must not exceed 35°C (95°F).

-
- ⚠ CAUTION:** To reduce the risk of damage to the equipment when installing third-party options:
- Do not permit optional equipment to impede airflow around the server or to increase the internal rack temperature beyond the maximum allowable limits.
 - Do not exceed the manufacturer's TMRA.
-

Power requirements

Installation of this equipment must comply with local and regional electrical regulations governing the installation of information technology equipment by licensed electricians. This equipment is designed to operate in installations covered by NFPA 70, 1999 Edition (National Electric Code) and NFPA-75, 1992 (code for Protection of Electronic Computer/Data Processing Equipment). For electrical power ratings on options, refer to the product rating label or the user documentation supplied with that option.

-
- ⚠ WARNING:** To reduce the risk of personal injury, fire, or damage to the equipment, do not overload the AC supply branch circuit that provides power to the rack. Consult the electrical authority having jurisdiction over wiring and installation requirements of your facility.
-

- ⚠ CAUTION:** Protect the server from power fluctuations and temporary interruptions with a regulating uninterruptible power supply (UPS). This device protects the hardware from damage caused by power surges and voltage spikes and keeps the system in operation during a power failure.
-

When installing more than one server, you may need to use additional power distribution devices to safely provide power to all devices. Observe the following guidelines:

- Balance the server power load between available AC supply branch circuits.
- Do not allow the overall system AC current load to exceed 80 percent of the branch circuit AC current rating.
- Do not use common power outlet strips for this equipment.
- Provide a separate electrical circuit for the server.

Electrical grounding requirements

The server must be grounded properly for proper operation and safety. In the United States, you must install the equipment in accordance with NFPA 70, 1999 Edition (National Electric Code), Article 250, as well as any local and regional building codes. In Canada, you must install the equipment in accordance with Canadian Standards Association, CSA C22.1, Canadian Electrical Code. In all other countries, you must install the equipment in accordance with any regional or national electrical wiring codes, such as the International Electrotechnical Commission (IEC) Code 364, parts 1 through 7. Furthermore, you must be sure that all power distribution devices used in the installation, such as branch wiring and receptacles, are listed or certified grounding-type devices.

Because of the high ground-leakage currents associated with multiple servers connected to the same power source, HP recommends the use of a PDU that is either permanently wired to the building's branch circuit or includes a nondetachable cord that is wired to an industrial-style plug. NEMA locking-style plugs or those complying with IEC 60309 are considered suitable for this purpose. Using common power outlet strips for the server is not recommended.

Rack planning resources

The rack resource kit ships with all HP branded or Compaq branded 9000, 10000, and H9 series racks. For more information on the content of each resource, refer to the rack resource kit documentation.

If you intend to deploy and configure multiple servers in a single rack, refer to the white paper on high-density deployment at the HP website (<http://www.hp.com/products/servers/platforms>).

Rack warnings



WARNING: To reduce the risk of personal injury or damage to the equipment, be sure that:

- The leveling jacks are extended to the floor.
 - The full weight of the rack rests on the leveling jacks.
 - The stabilizing feet are attached to the rack if it is a single-rack installation.
 - The racks are coupled together in multiple-rack installations.
 - Only one component is extended at a time. A rack may become unstable if more than one component is extended for any reason.
-



WARNING: To reduce the risk of personal injury or equipment damage when unloading a rack:

- At least two people are needed to safely unload the rack from the pallet. An empty 42U rack can weigh as much as 115 kg (253 lb), can stand more than 2.1 m (7 ft) tall, and may become unstable when being moved on its casters.
 - Never stand in front of the rack when it is rolling down the ramp from the pallet. Always handle the rack from both sides.
-

Contents of the tower server shipping carton

Unpack the server shipping carton and locate the materials and documentation necessary for installing the server.

The contents of the server shipping carton include:

- Server
- Tower server feet
- Power cord
- Keyboard (not included in all regions)
- Mouse (not included in all regions)
- This document, Documentation CD, and software products

In addition to the supplied items, you may need:

- T-15 Torx screwdriver
- Hardware options
- Operating system or application software

- UPS

Contents of the rack server shipping carton

Unpack the server shipping carton and locate the materials and documentation necessary for installing the server. All the rack mounting hardware necessary for installing the server into the rack is included with the rack or the server.

The contents of the server shipping carton include:

- Server
- Power cord
- Hardware documentation, Documentation CD, and software products
- Rack-mounting hardware

In addition to the supplied items, you may need:

- T-15 Torx screwdriver
- Hardware options
- Operating system or application software
- PDU

Installing hardware options

Install any hardware options before initializing the server. For options installation information, refer to the option documentation. For server-specific information, refer to "Hardware options installation (on page 29)."

Setting up a tower server

Follow the steps in this section to set up a tower model server. If you are going to install the server into a rack, refer to the rack installation ("[Installing the server into the rack](#)" on page 26) section.

1. Install the feet.

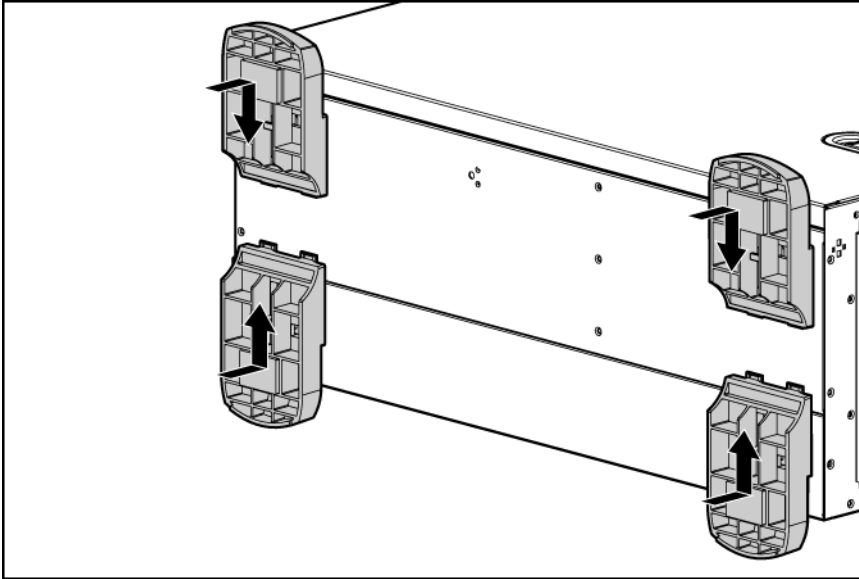

2. Return the server to an upright position.
3. Connect peripheral devices to the server ("[Rear panel components](#)" on page 9).

⚠ WARNING: To reduce the risk of electric shock, fire, or damage to the equipment, do not plug telephone or telecommunications connectors into RJ-45 connectors.

4. Connect the power cord to the rear of the server.
5. Connect the power cord to the AC power source.

⚠ WARNING: To reduce the risk of electric shock or damage to the equipment:

- Do not disable the power cord grounding plug. The grounding plug is an important safety feature.
- Plug the power cord into a grounded (earthed) electrical outlet that is easily accessible at all times.
- Unplug the power cord from the power supply to disconnect power to the equipment.
- Do not route the power cord where it can be walked on or pinched by items placed against it. Pay particular attention to the plug, electrical outlet, and the point where the cord extends from the server.

Installing the server into the rack



WARNING: This server is very heavy. To reduce the risk of personal injury or damage to the equipment:

- Observe local occupational health and safety requirements and guidelines for manual material handling.
- Get help to lift and stabilize the product during installation or removal, especially when the product is not fastened to the rails. When the server weighs more than 22.5 kg (50 lb), at least two people must lift the server into the rack together. A third person may be required to help align the server if the server is installed higher than chest level.
- Use caution when installing the server in or removing the server from the rack; it is unstable when not fastened to the rails.



CAUTION: Always plan the rack installation so that the heaviest item is on the bottom of the rack. Install the heaviest item first, and continue to populate the rack from the bottom to the top.

1. Install the server and cable management arm into the rack. Refer to the installation instructions that ship with the 3-7U Quick Deploy Rail System.
2. Install an additional extender bracket (included with the server) to the cable management arm. Refer to "Converting the cable management arm swing" in the installation instructions that ship with the 3-7U Quick Deploy Rail System.

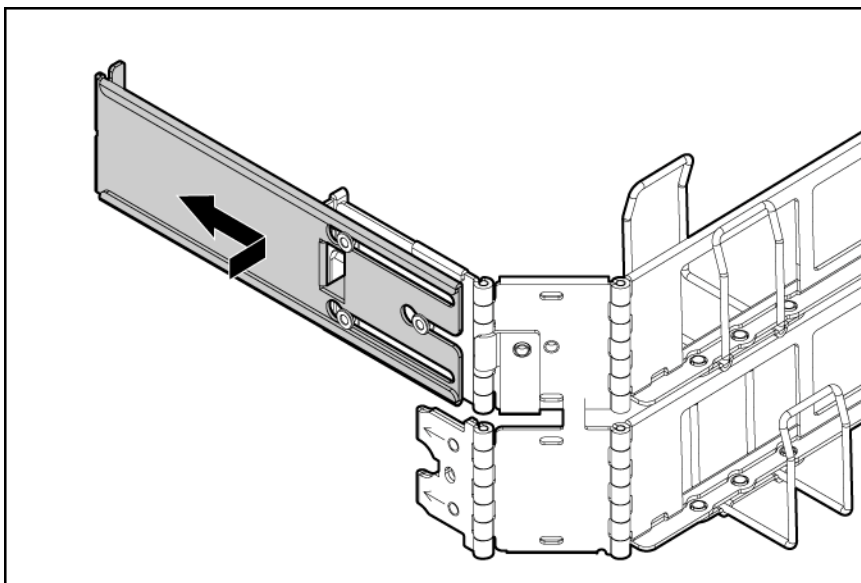

3. Connect peripheral devices to the server ("[Rear panel components](#)" on page 9).
4. Connect the power cord to the rear of the server.
5. Connect the power cord to the AC power source.

Powering up and configuring the server

To power up the server, press the Power On/Standby button.

While the server boots, RBSU and the ORCA utility are automatically configured to prepare the server for operating system installation.

To configure these utilities manually:

- Press the **F8** key when prompted during the array controller initialization to configure the array controller using ORCA.
- Press the **F9** key when prompted during the boot process to change the server settings using RBSU. The system is set up by default for the English language.

For more information on the automatic configuration, refer to the *HP ROM-Based Setup Utility User Guide* located on the Documentation CD.

Installing the operating system

To operate properly, the server must have a supported operating system. For the latest information on supported operating systems, refer to the HP website (<http://www.hp.com/go/supportos>).

Two methods are available to install an operating system on the server:

- SmartStart assisted installation—Insert the SmartStart CD into the CD-ROM drive and reboot the server.
- Manual installation—Insert the operating system CD into the CD-ROM drive and reboot the server. This process may require you to obtain additional drivers from the HP website (<http://www.hp.com/support>).

Follow the on-screen instructions to begin the installation process.

For information on using these installation paths, refer to the SmartStart installation poster in the HP ProLiant Essentials Foundation Pack, included with the server.

Registering the server

To register the server, refer to the HP Registration website (<http://register.hp.com>).

Hardware options installation

Introduction

If more than one option is being installed, read the installation instructions for all the hardware options and identify similar steps to streamline the installation process.

-
-  **WARNING:** To reduce the risk of personal injury from hot surfaces, allow the drives and the internal system components to cool before touching them.

 -  **CAUTION:** To prevent damage to electrical components, properly ground the server before beginning any installation procedure. Improper grounding can cause electrostatic discharge.

Processor option

The server supports single- and dual-processor operation. With two processors installed, the server supports boot functions through the processor installed in processor socket 1. However, if processor 1 fails, the system automatically boots from processor 2 and provides a processor failure message.

The server uses an embedded PPM 1 as a DC-to-DC converter to provide the proper power to processor 1.

-
-  **CAUTION:** To prevent possible server malfunction, do not mix processors of different speeds or cache sizes. Refer to the label on the processor heatsink for a description of the processor.

 -  **IMPORTANT:** Processor socket 1 must be populated at all times or the server does not function.

 -  **CAUTION:** Removal of the processor or heatsink renders the thermal layer between the processor and heatsink useless. A new heatsink must be ordered and installed before reinstalling the processor.

To install the component:

1. Update the system ROM.
Locate and download the latest ROM version from the HP website (<http://h18023.www1.hp.com/support/files/server/us/romflash.html>). Follow the instructions on the website to update the system ROM.
2. Power down the server (on page 17).
3. Do one of the following:
 - Open or remove the tower bezel, as needed ("Open or remove the tower bezel" on page 18).
 - Extend the server from the rack (on page 17).
4. Remove the access panel (on page 19).

5. Open the processor retaining latch and the processor socket retaining bracket.

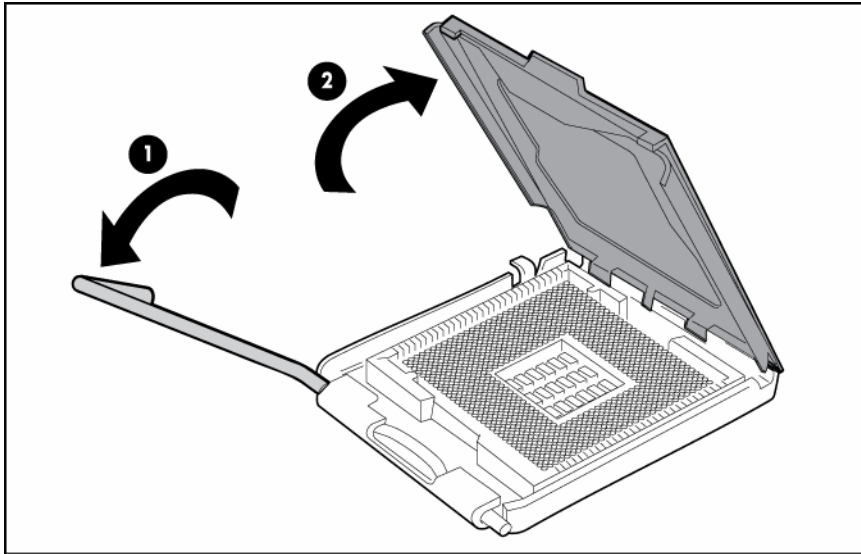

6. Remove the processor socket protective cover.

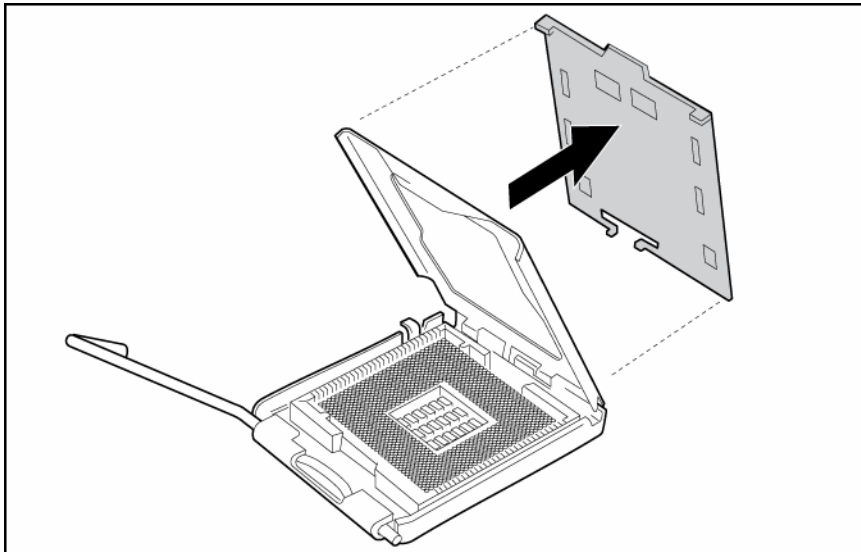

IMPORTANT: Be sure the processor remains inside the processor installation tool.

7. If the processor has separated from the installation tool, carefully re-insert the processor in the tool.

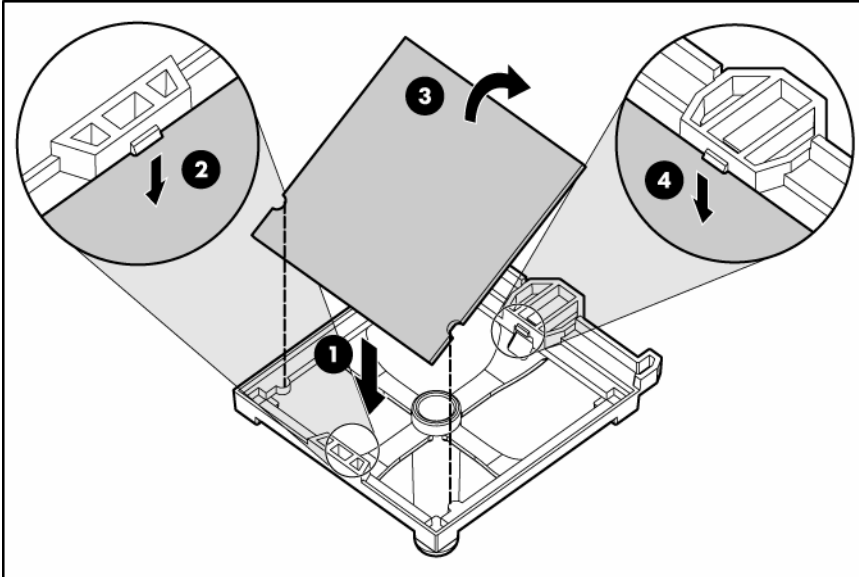

8. Align the processor installation tool with the socket and install the processor.

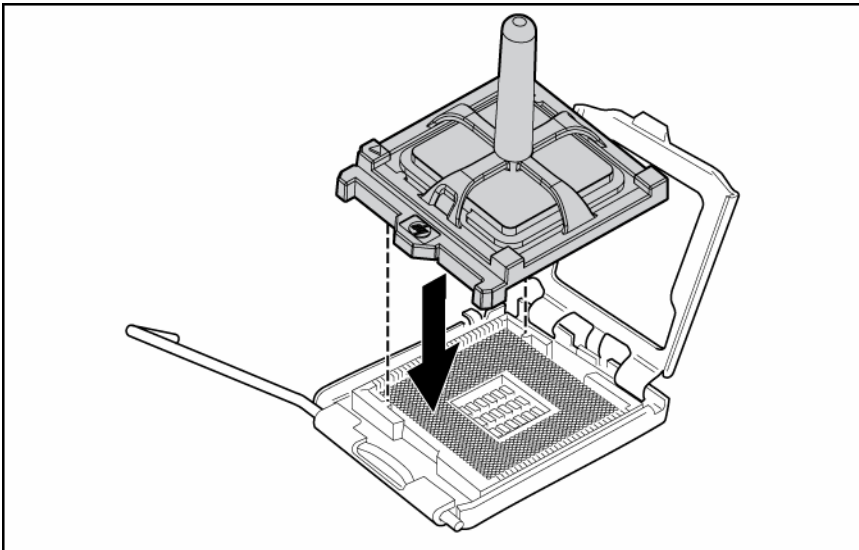

9. Press down firmly until the processor installation tool clicks and separates from the processor, and then remove the processor installation tool.

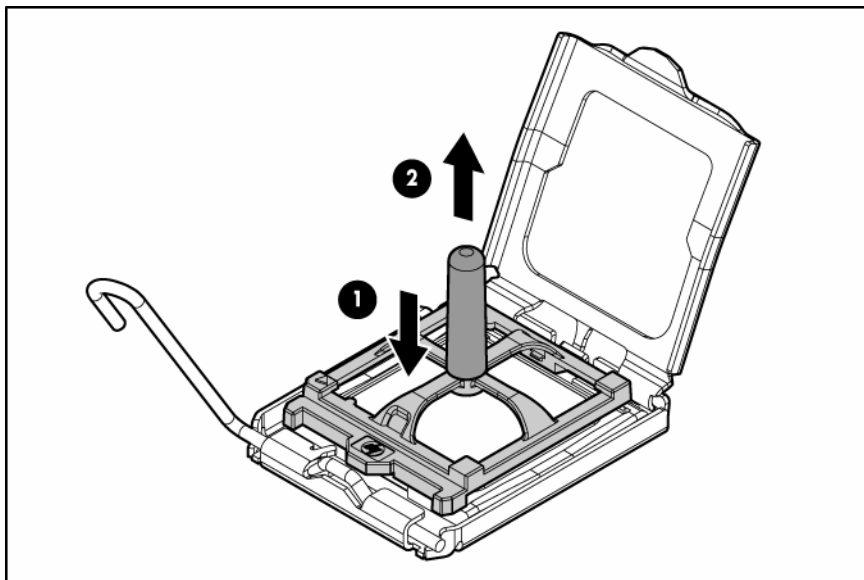

10. Close the processor socket retaining bracket and the processor retaining latch.

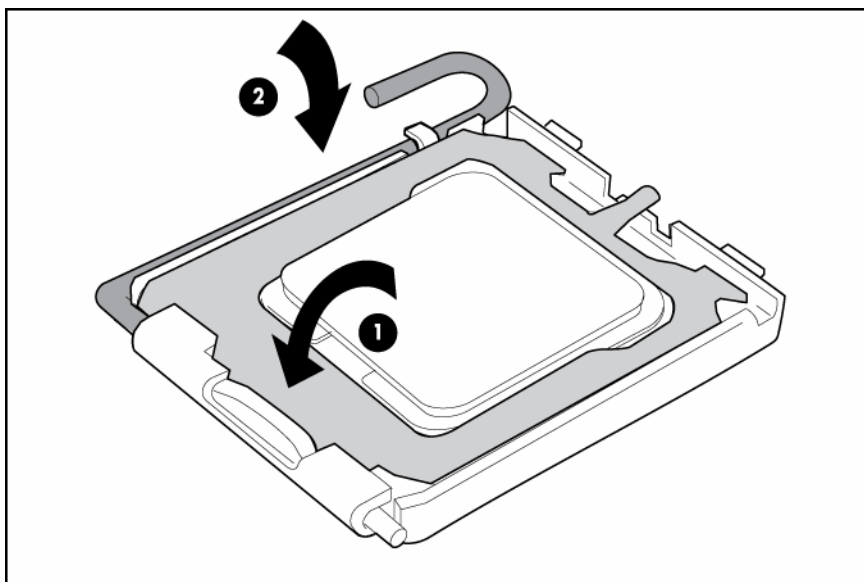

11. Open the heatsink locking levers.

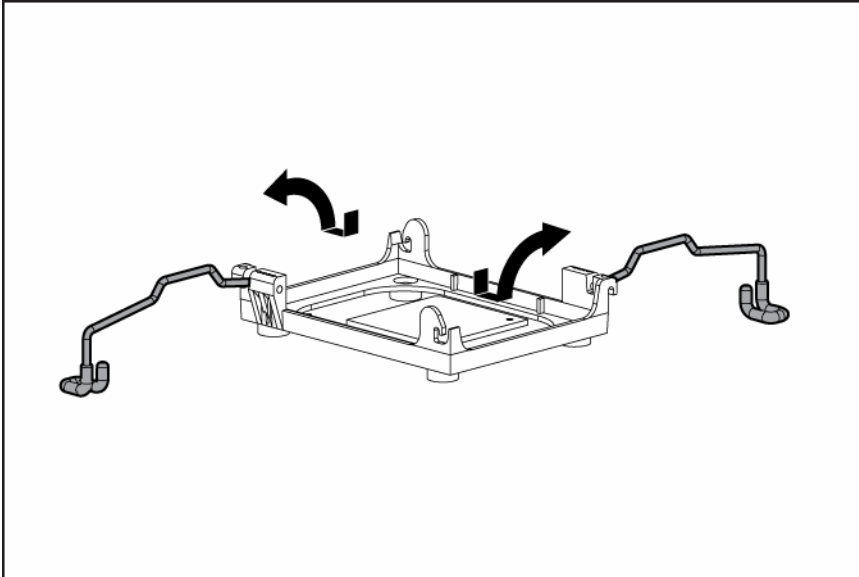

12. Remove the heatsink protective cover.

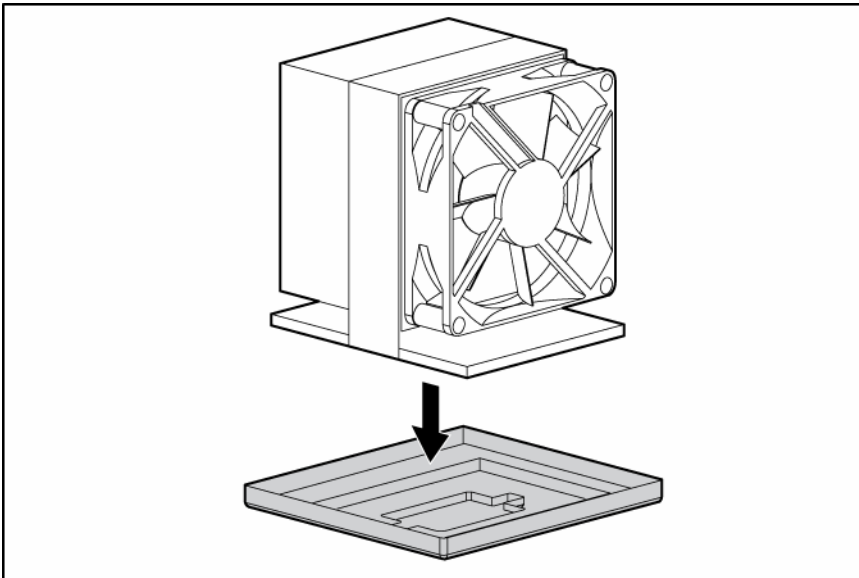

13. Install the heatsink fan. The heatsink fan points to the rear of the server.

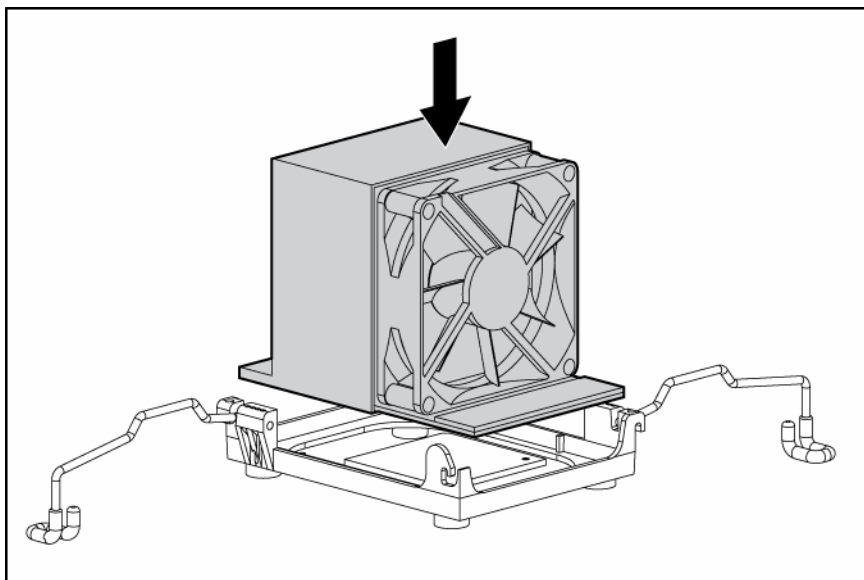

14. Close the heatsink locking levers.

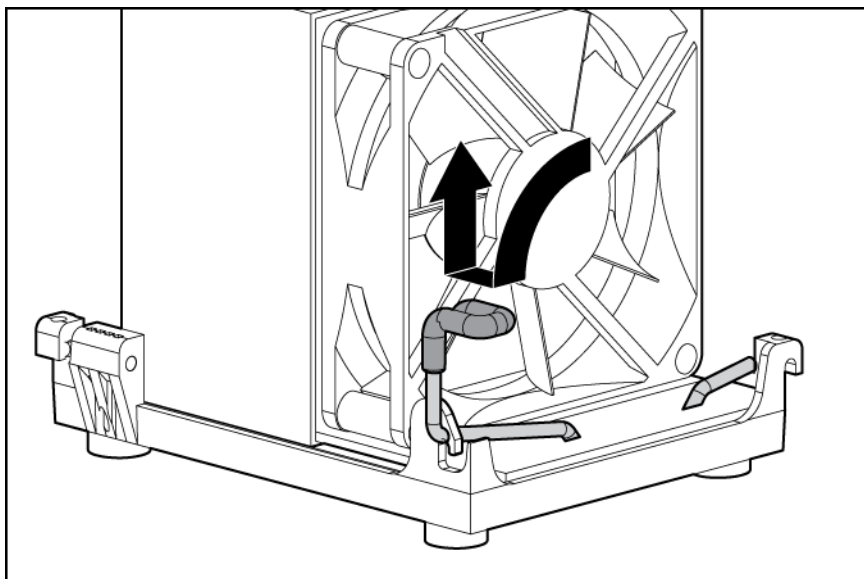

15. Connect the heatsink fan cable to the connector on the system board ("[System board components](#)" on page 11).

16. Install the PPM.

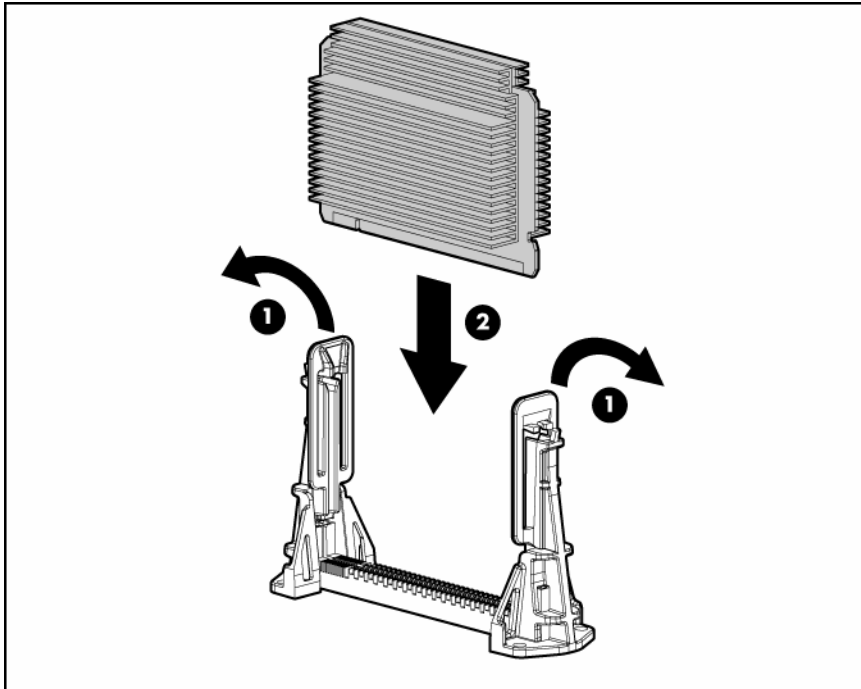

17. Close the latches.

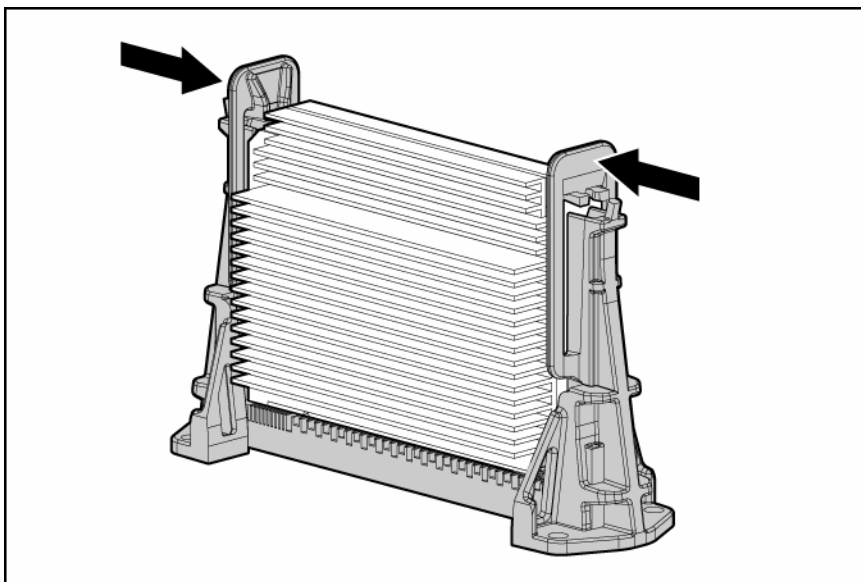

NOTE: The appearance of compatible PPMs may vary.

18. Install the access panel (on page 20).
19. Do one of the following:
 - Close or install the tower bezel, as needed.
 - Slide the server back into the rack.
20. Power up the server (on page 17).

Memory options

This server contains eight FBDIMM slots. You can expand server memory by installing supported Registered DDR-2 FBDIMMs.

Memory configurations

The server supports the following Advanced Memory Protection (AMP) options to optimize server availability.

- Advanced ECC supporting up to 16 GB of active memory using 2-GB FBDIMMs.
- Online Spare Memory providing additional protection against degrading FBDIMMs supporting up to 14 GB of active memory and 2 GB of online spare memory utilizing 2-GB FBDIMMs.

Maximum memory capacities for all AMP modes will increase with the availability of 4-GB and 8-GB FBDIMMs, including a maximum of 64 GB in Advanced ECC mode. For the latest memory configuration information, refer to the QuickSpecs on the HP website (<http://www.hp.com>).

The Advanced Memory Protection option is configured in RBSU. By default, the server is set to Advanced ECC mode. For more information, refer to HP ROM-Based Setup Utility. If the configured AMP mode is not supported by the installed FBDIMM configuration, the system boots in Advanced ECC mode.

The following configuration requirements apply to all AMP modes:

- FBDIMMs must be ECC Registered DDR-2 SDRAM FBDIMMs.
- FBDIMMs must be installed in pairs.
- FBDIMMs must be populated as specified for each AMP memory mode.

Advanced ECC memory

Advanced ECC memory is the default memory protection mode for this server. In Advanced ECC, the server is protected against correctable memory errors. The server provides notification if the level of correctable errors exceeds a pre-defined threshold rate. The server does not fail because of correctable memory errors. Advanced ECC provides additional protection over Standard ECC because it is possible to correct certain memory errors that would otherwise be uncorrectable and result in a server failure.

Whereas standard ECC can correct single-bit memory errors, Advanced ECC can correct single-bit memory errors and multi-bit memory errors if all failed bits are on the same DRAM device on the FBDIMM.

In addition to general configuration requirements, Advanced ECC memory also has the following configuration requirements:

- FBDIMMs must be installed in pairs unless operating in single-FBDIMM mode. The server supports single-FBDIMM mode only in FBDIMM slot 1A.
- FBDIMMs must be installed in sequential order, beginning with bank A.

In Advanced ECC mode, FBDIMMs must be populated as specified in the following table, unless a single DIMM is used:

Configuration	Bank A 1A and 5A	Bank B 2B and 6B	Bank C 3C and 7C	Bank D 4D and 8D
1	X	—	—	—
2	X	X	—	—
3	X	X	X	—
4	X	X	X	X

Online spare memory configuration

Online spare memory provides protection against degrading FBDIMMs by reducing the likelihood of uncorrectable memory errors.

An understanding of single-rank and dual-rank FBDIMMs is required to understand memory usage in online spare mode. FBDIMMs can either be single-rank or dual-rank. Certain FBDIMM configuration requirements are based on these classifications. A dual-rank FBDIMM is similar to having two separate FBDIMMs, or ranks, on the same module. Although only a single FBDIMM module, a dual-rank FBDIMM acts as two separate FBDIMMs. The purpose of dual-rank FBDIMMs is to provide the largest capacity FBDIMM for the current DRAM technology. If the current DRAM technology allows for 2-GB single-rank FBDIMMs, a dual-rank FBDIMM using the same technology would be 4-GB.

In online spare mode, a single rank of memory acts as the spare memory. For single-rank FBDIMMs, the entire FBDIMM acts as the spare memory. For a dual-rank FBDIMM, only half of the FBDIMM acts as the spare memory while the other half is available for operating system and application usage.

If one of the non-spare FBDIMMs receives correctable memory errors at a higher rate than a specific threshold, the server automatically copies the memory contents of the degraded rank to the online spare rank. The server then deactivates the failing rank and automatically switches over to the online spare. Because FBDIMMs that experience a high rate of correctable memory errors have a higher probability of receiving an uncorrectable memory error, this effectively reduces the likelihood of uncorrectable memory errors that would result in server downtime.

Online spare FBDIMM configuration requirements (in addition to general configuration requirements):

- When only bank A is being used, it must be fully populated with dual-rank FBDIMMs.
- For optimum memory usage, HP recommends all FBDIMMs be the same size with the same HP part number. If different sized FBDIMMs are used, a portion of the installed memory may not be utilized.

In online spare mode, FBDIMMs must be populated as specified in the following table:

Configuration	Bank A 1A and 5A	Bank B 2B and 6B	Bank C 3C and 7C	Bank D 4D and 8D
1*	X	—	—	—
2	X	X	—	—
3	X	X	X	X

* Configuration 1 is only supported if using bank A, populated with dual-rank FBDIMMs.

After installing FBDIMMs, use RBSU to configure the system for online spare memory support.

Installing FBDIMMs

CAUTION: To avoid damage to the hard drives, memory, and other system components, the air baffle, drive blanks, and access panel must be installed when the server is powered up.

1. Power down the server (on page 17).
2. Extend the server from the rack (on page 17).
3. Remove the access panel (on page 19).
4. Move the hard drive cables.
5. Remove the air baffle.
6. Open the FBDIMM slot latches.
7. Install the FBDIMM.

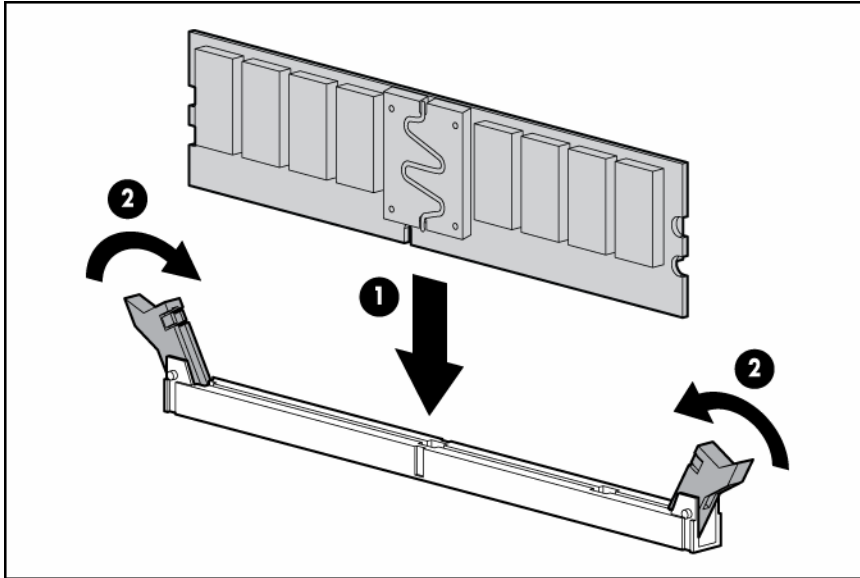

8. Install the air baffle.
9. Install the access panel (on page 20).
10. If you are installing FBDIMMs in an online spare or mirrored configuration, use RBSU to configure this feature.

Hard drive blank

To remove a hard drive blank:

1. Open the bezel (tower model)
2. Squeeze the tabs to release the blank, and pull the blank out.

CAUTION: To prevent improper cooling and thermal damage, do not operate the server unless all bays are populated with either a component or a blank.

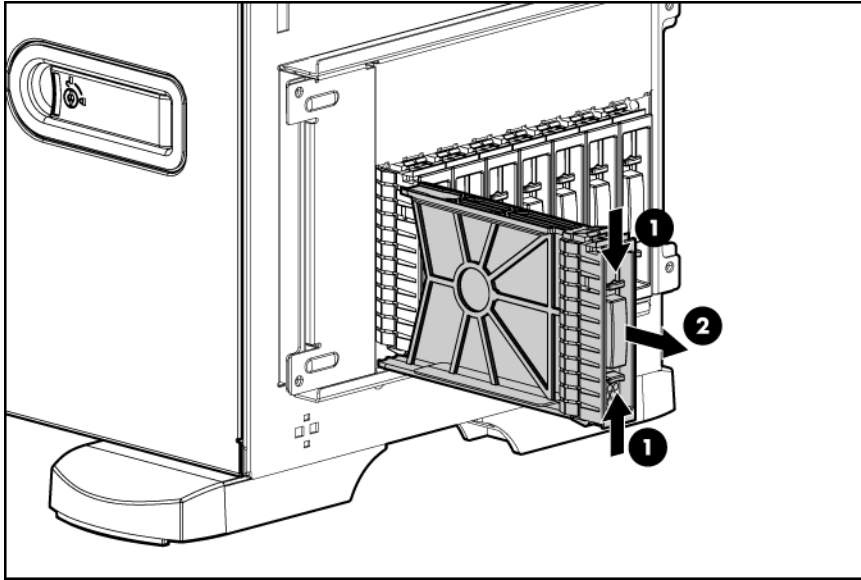

NOTE: Depending on model purchased, the server may look slightly different than shown.

SATA or SAS hard drive option



IMPORTANT: When installing a x3/x1 SAS cable in a SFF system, HP recommends that the x3 part of the x3/x1 cable be linked to the SAS hard drive backplane connector that corresponds to hard drive slots 1 to 4. In this setup, hard drive slot 1 will not be available, but since hard drive slots 2 to 4 will be connected, one continuous volume can be created. All drive slots will be available in LFF systems.

To install the component:

1. Open the bezel (tower model) ("[Open or remove the tower bezel](#)" on page 18).
2. Remove the existing hard drive blank (on page 38).

NOTE: Depending on model purchased, the server may look slightly different than shown.

3. Open the release latch to prepare the drive for installation.

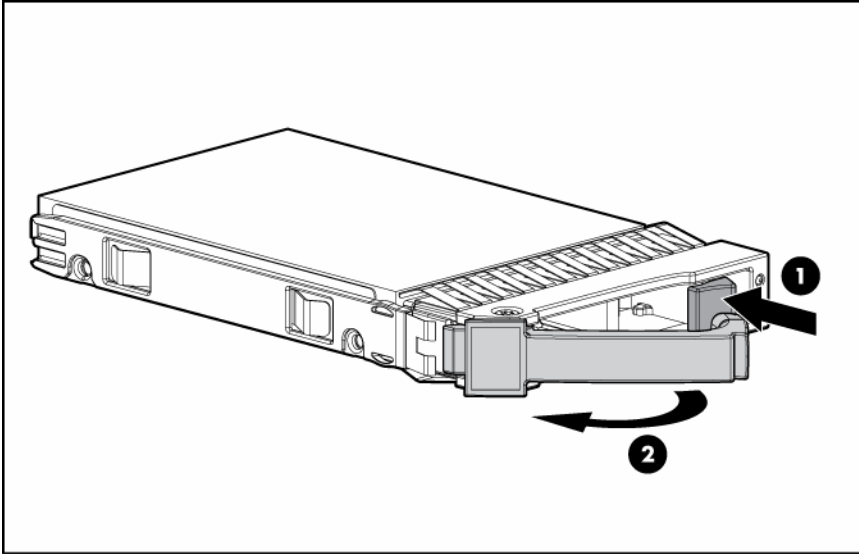

4. Install the drive.

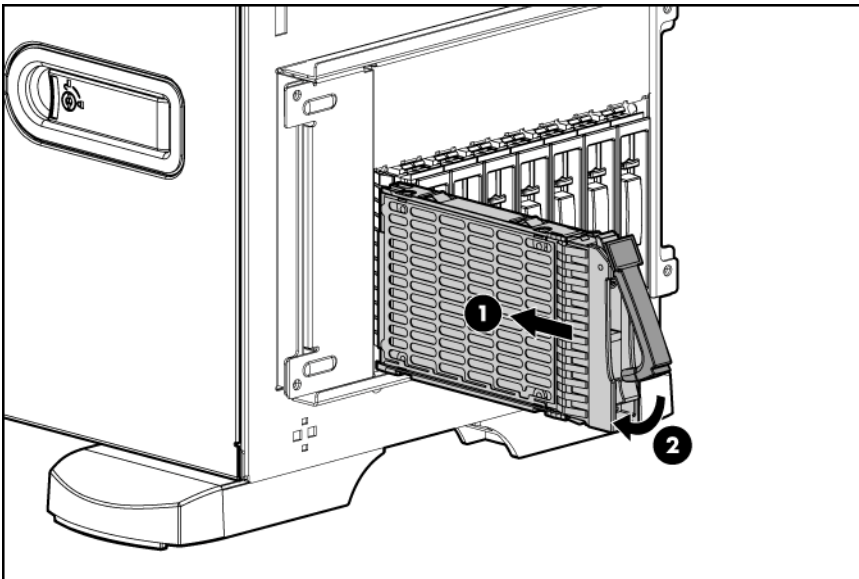

5. Determine the status of the drive by observing the drive LEDs ("SAS and SATA hard drive LEDs" on page 15).
6. Close the bezel (tower model).
7. Resume normal server operations.

Removable media device options

Accessing the removable media cage

The server supports installation of optional internal storage devices. To access the components:

1. Power down the server (on page 17).
2. Do one of the following:

- Open or remove the tower bezel, as needed ("[Open or remove the tower bezel](#)" on page [18](#)).
 - Extend the server from the rack (on page [17](#)).
3. Remove the access panel (on page [19](#)).

△ CAUTION: Always populate each media bay with either a device or a blank. Proper airflow can only be maintained when the bays are populated. Unpopulated drive bays can lead to improper cooling and thermal damage.

4. Remove the media bay blank.

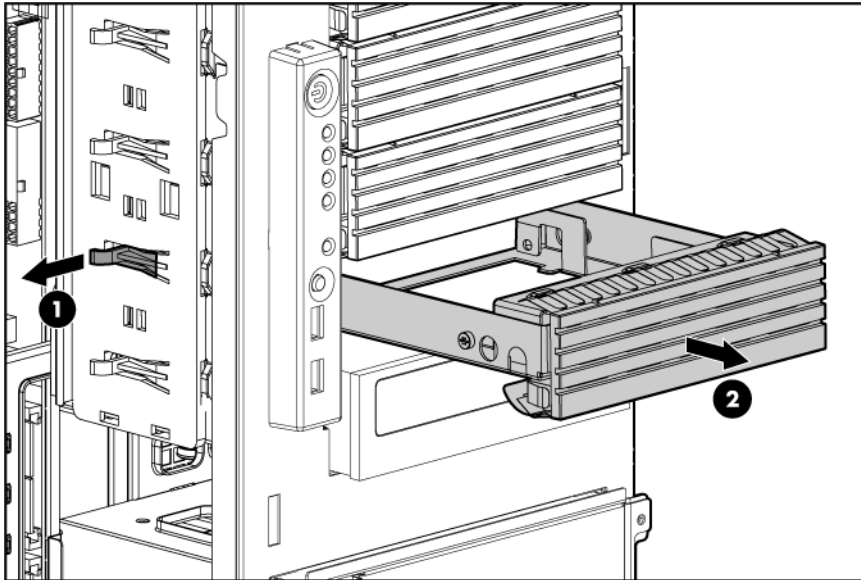

5. Install other hardware options as needed.
6. Install the access panel (on page [20](#)).
7. Do one of the following:
- Close or install the tower bezel, as needed.
 - Slide the server back into the rack.

Identifying guide screws

When installing drives in the removable media bay, guide screws must be installed to make sure the drives correctly align in the drive cage. HP has provided extra guide screws, located behind the side access panel. Depending on the option, use 5.25 M3 metric screws or HD 6-32 shipping screws. The metric screws supplied by HP are black.

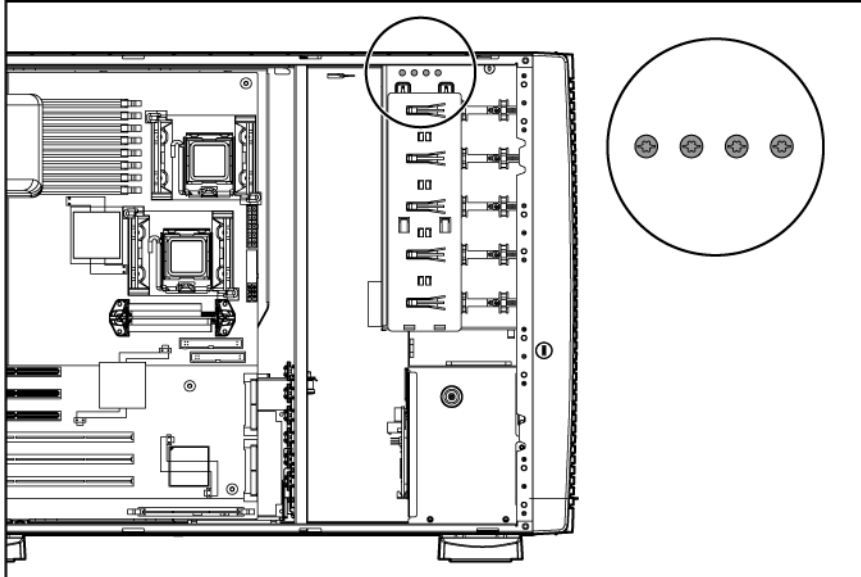

Installing a half-height or full-height media device

The server includes five removable media bays. The server ships with an optical drive and the other four bays are vacant. You can install two full-height removable or up to four additional half-height media devices in the removable media cage. To install a half-height or full-height media device:

1. Power down the server (on page 17).
2. Do one of the following:
 - o Open or remove the tower bezel, as needed ("[Open or remove the tower bezel](#)" on page 18).
 - o Extend the server from the rack (on page 17).
3. Remove the access panel (on page 19).
4. Remove the media bay blank ("[Accessing the removable media cage](#)" on page 40).
5. Install the guide screws ("[Identifying guide screws](#)" on page 42), if applicable.
6. Slide the drive into the bay until it clicks into place.

- Half-height device

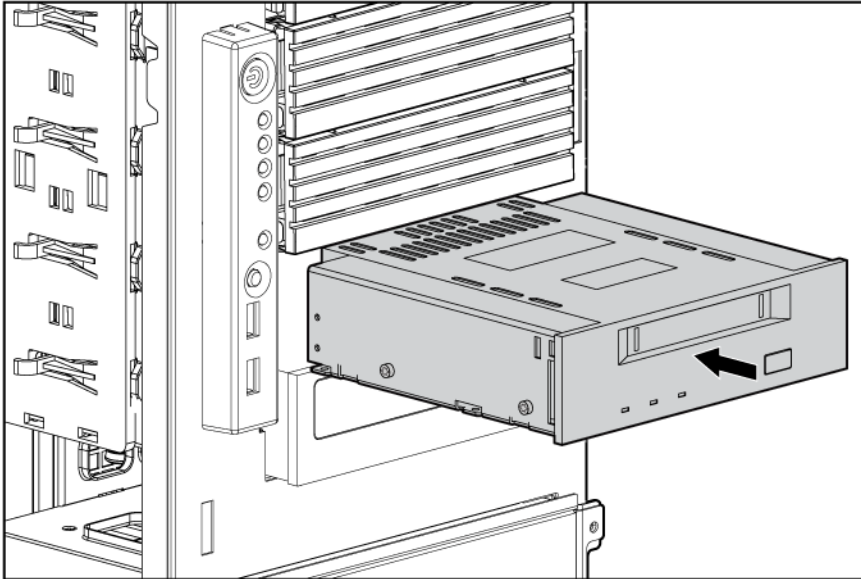

- Full-height device

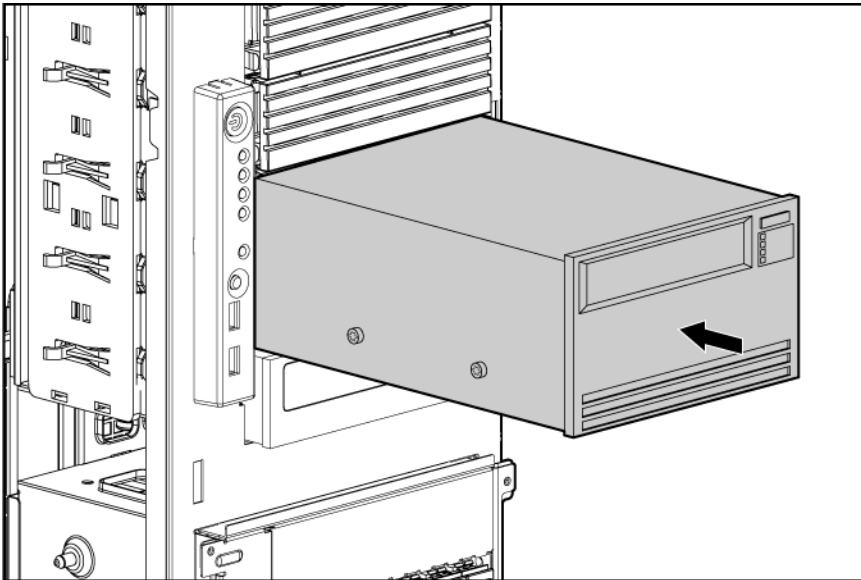

7. (Optional) When shipping a server with a full-height device installed, replace the front guide screw with a shipping screw ("[Installing the full-height media device shipping screw](#)" on page 44).
8. Connect the data and power cables to the rear of the device:



IMPORTANT: If both SATA and PATA optical devices are installed simultaneously, only one can boot at a time. Boot priority will go to SATA if media is inserted into the SATA optical drive. Boot priority for PATA is not configurable. To boot PATA, remove the media from the SATA optical device, or remove the SATA optical device.

- PATA CD-ROM drive

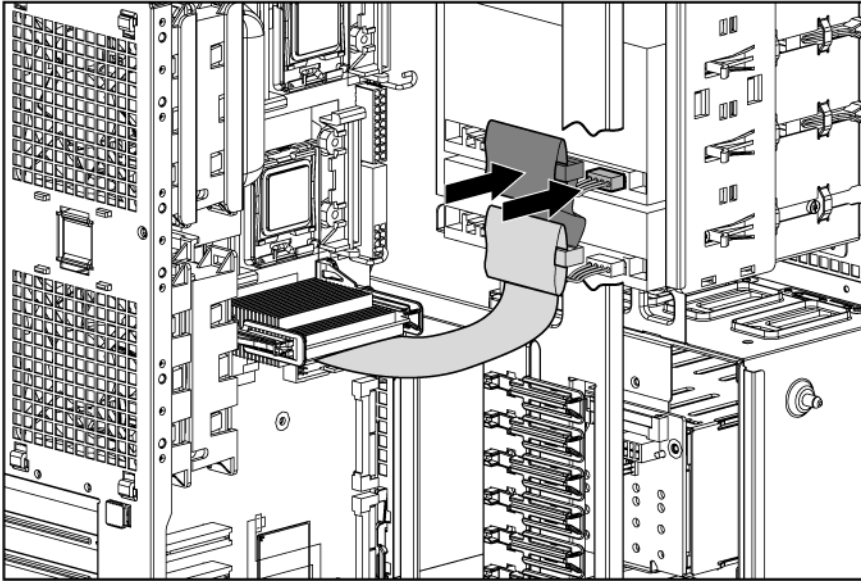

IMPORTANT: Be sure to connect the right-angle end of the SATA data cable to the system board. Connecting it to the SATA drive may interfere with other installed media bay devices.

- SATA DVD-ROM drive

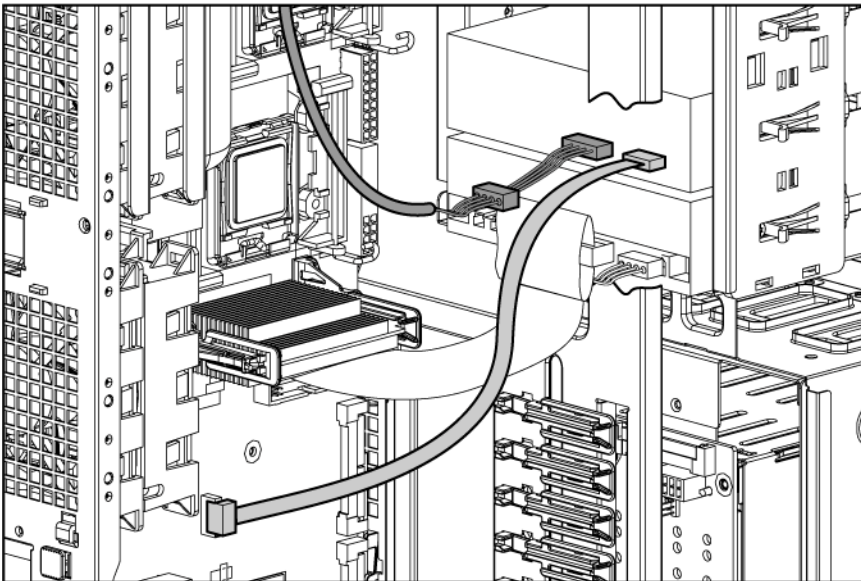

9. Install the access panel (on page 20).
10. Do one of the following:
 - Close or install the tower bezel, as needed.
 - Slide the server back into the rack.

Installing the full-height media device shipping screw

When shipping a server with a full-height media device installed, always install a shipping screw to secure the device.

1. Install the full-height media device ("[Installing a half-height or full-height media device](#)" on page 42).
2. Remove the front guide screw from the full-height media device, and the silver shipping screw from the chassis.

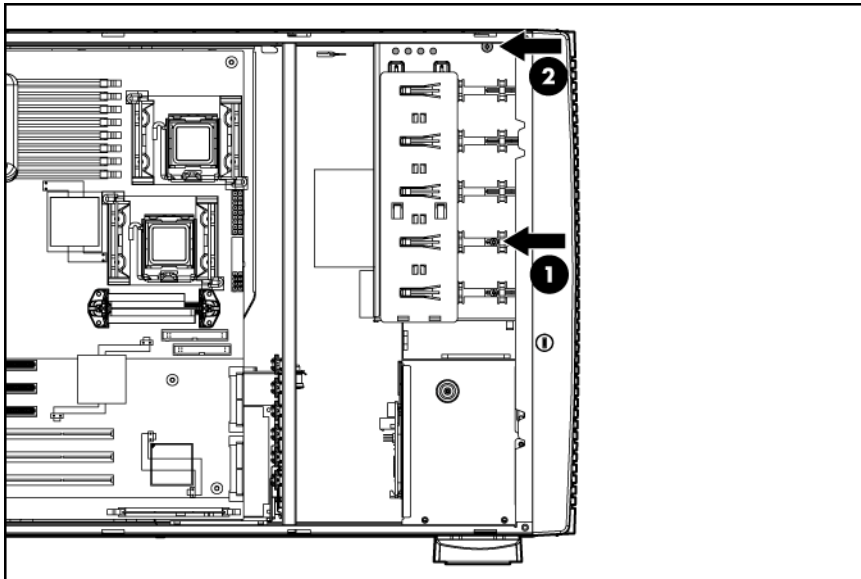

3. Install the silver shipping screw into the full-height device.

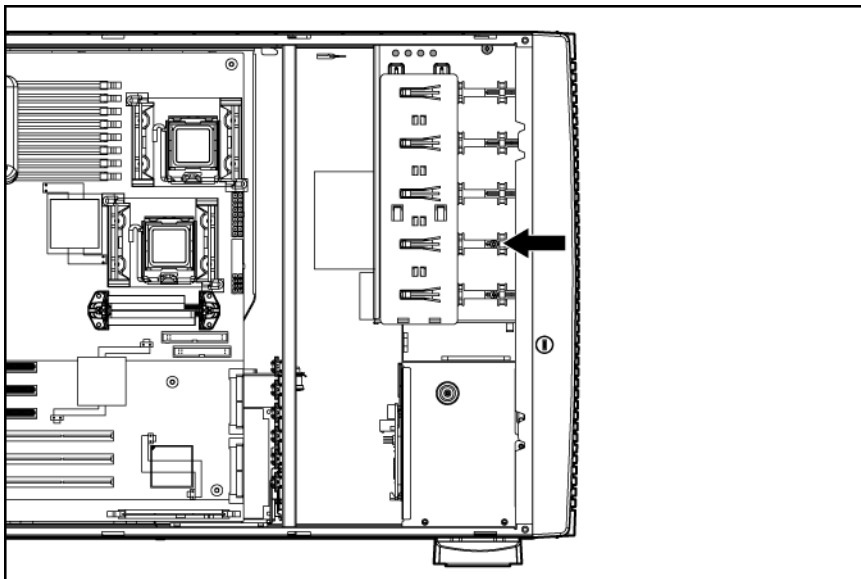

Installing a diskette drive

1. Power down the server (on page 17).
2. Do one of the following:
 - o Open or remove the tower bezel, as needed ("[Open or remove the tower bezel](#)" on page 18).
 - o Extend the server from the rack (on page 17).
3. Remove the media bay blank ("[Accessing the removable media cage](#)" on page 40).
4. Remove the access panel (on page 19).
5. Use a T-15 Torx screwdriver to remove the four 6-32 screws from the media bay blank.

6. Install the screws into the diskette drive, as shown.

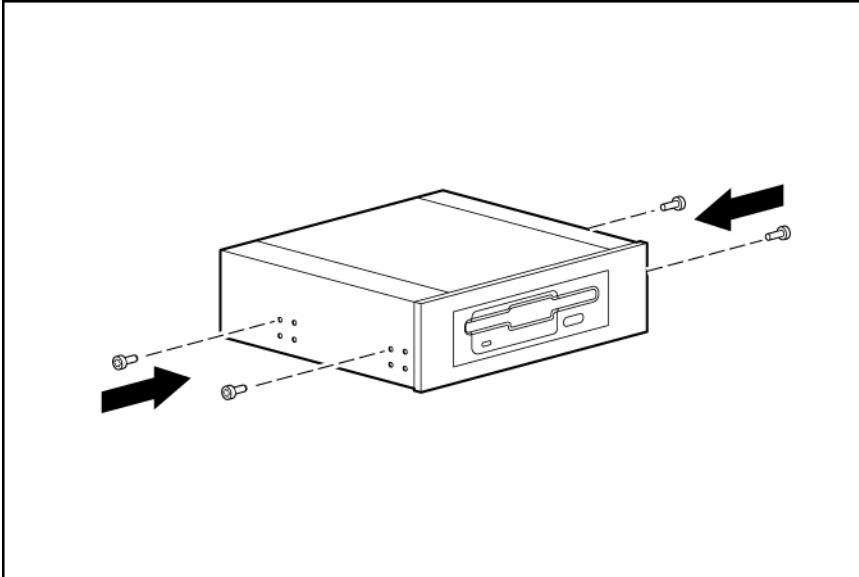

7. Slide the diskette drive into the diskette drive bay.

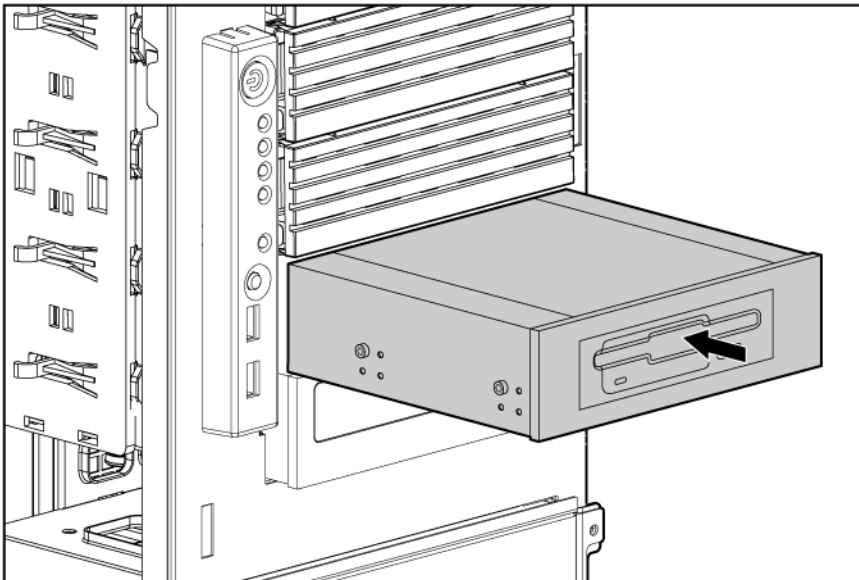

8. Connect the data and power cables to the rear of the device.
9. Connect the diskette drive cable to the diskette drive cable connector on the system board ("[System board components](#)" on page 11).
10. Install the access panel (on page 20).
11. Do one of the following:
 - o Close or install the tower bezel, as needed.
 - o Slide the server back into the rack.
12. Power up the server (on page 17).

Redundant hot-plug power supply option

⚠ WARNING: To reduce the risk of personal injury or damage to the equipment, the installation of power supplies should be performed only by individuals who are qualified in servicing server equipment and trained to deal with products capable of producing hazardous energy levels.

⚠ WARNING: To reduce the risk of personal injury from hot surfaces, observe the thermal labels on each power supply or module.

⚠ WARNING: To reduce the risk of injury from electric shock hazards, do not open power supplies. Refer all maintenance, upgrades, and servicing to qualified personnel.

⚠ CAUTION: Electrostatic discharge (ESD) can damage electronic components. Be sure that you are properly grounded (earthed) before beginning any installation procedure.

To install the component:

1. Identify the redundant power supply bay ("Rear panel components" on page 9).



IMPORTANT: Power supplies for the model shown are hot-pluggable. When using the redundant power supply option, it is not necessary to power down the server before removing or installing a power supply.

2. Remove the power supply blank.

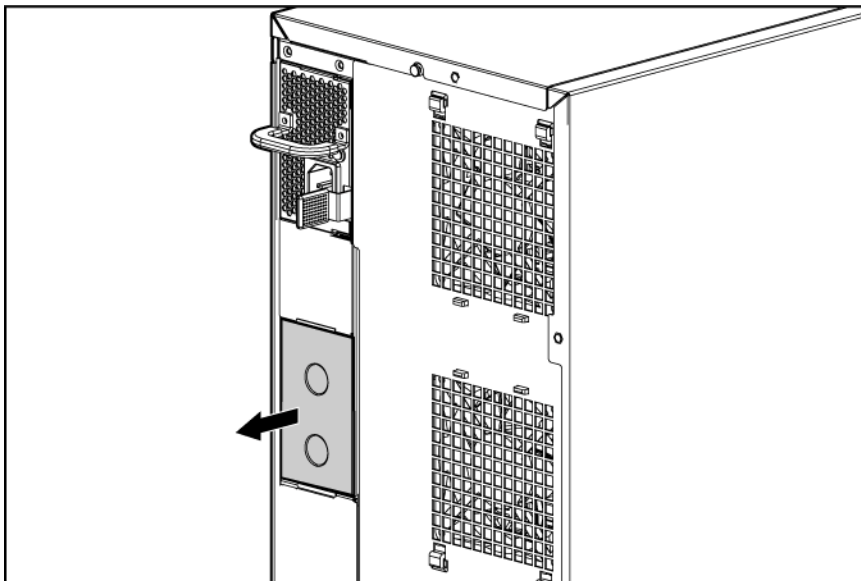

⚠ WARNING: To reduce the risk of electric shock or damage to the equipment, do not connect AC power cords to uninstalled power supplies.

3. Slide the power supply into the power supply bay until the release/lock lever clicks, securing the power supply.

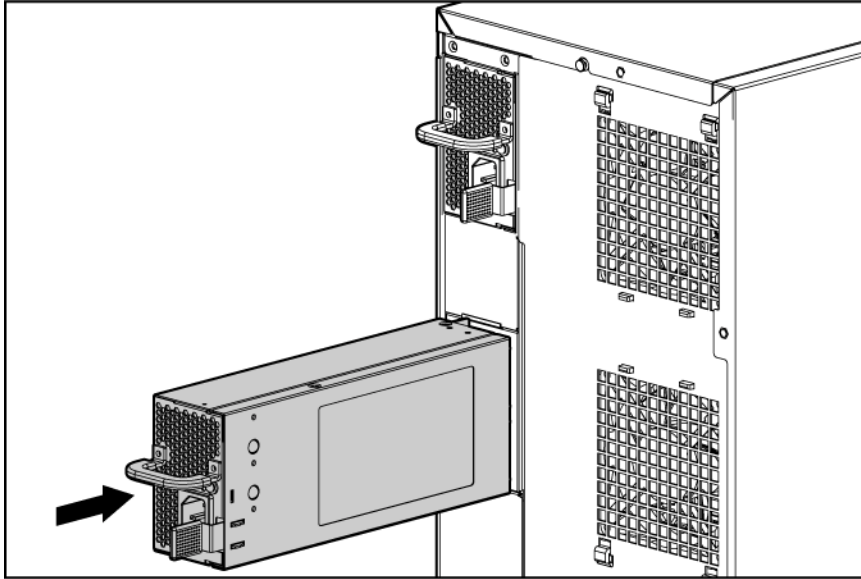

4. Using the retaining clip shipped with the server, secure the power cord to the power supply handle. Securing the cord will ensure enough slack.
5. Connect the power cord to the power supply.
6. Connect the power cord to the AC power source.
7. Be sure that the power supply and external health LEDs are illuminated green.

Expansion board options

The server supports PCI, PCI-X, and PCI Express expansion boards.

Removing the expansion slot cover

To install the component:

1. Power down the server (on page 17).
2. Do one of the following:
 - o Open or remove the tower bezel, as needed ("[Open or remove the tower bezel](#)" on page 18).
 - o Extend the server from the rack (on page 17).
3. Remove the access panel (on page 19).

4. Push the release latches on the expansion board retainer and pull the retainer out away from the chassis.

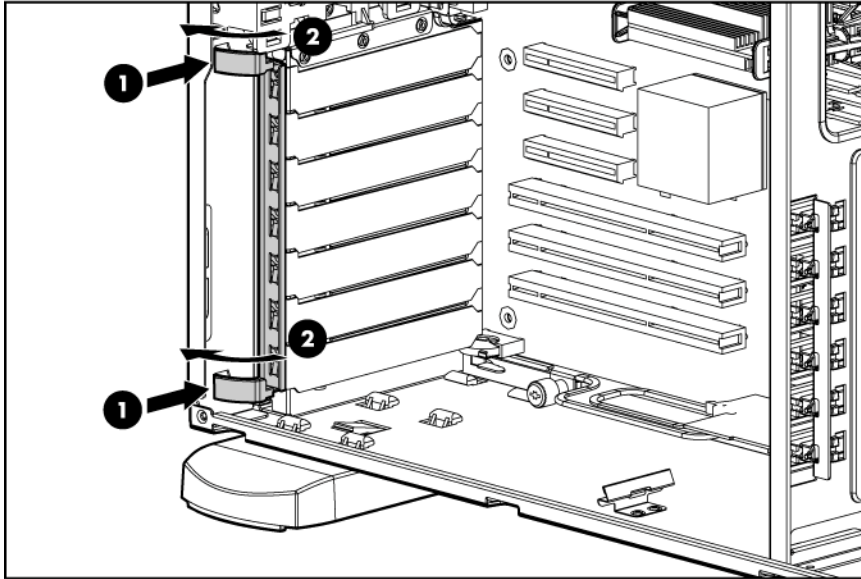

5. Remove the expansion slot cover.

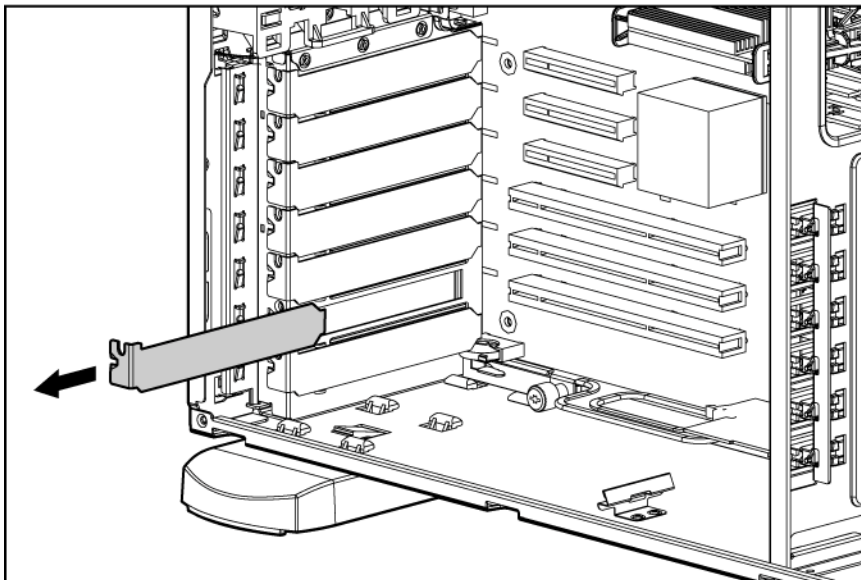

CAUTION: To prevent improper cooling and thermal damage, do not operate the server unless all PCI slots have either an expansion slot cover or an expansion board installed.

Installing an expansion board

CAUTION: To prevent damage to the server or expansion boards, power down the server and remove all AC power cords before removing or installing the expansion boards.

1. Power down the server (on page 17).
2. Do one of the following:
 - o Open or remove the tower bezel, as needed ("[Open or remove the tower bezel](#)" on page 18).

- Extend the server from the rack (on page 17).
- 3. Remove the access panel (on page 19).
- 4. Remove the expansion slot cover from the slot, if installed ("[Removing the expansion slot cover](#)" on page 48).



IMPORTANT: It may be necessary to remove the slot cover next to the slot in which you are installing a board.

- 5. Push the release latches on the expansion board retainer and pull the retainer out away from the chassis.

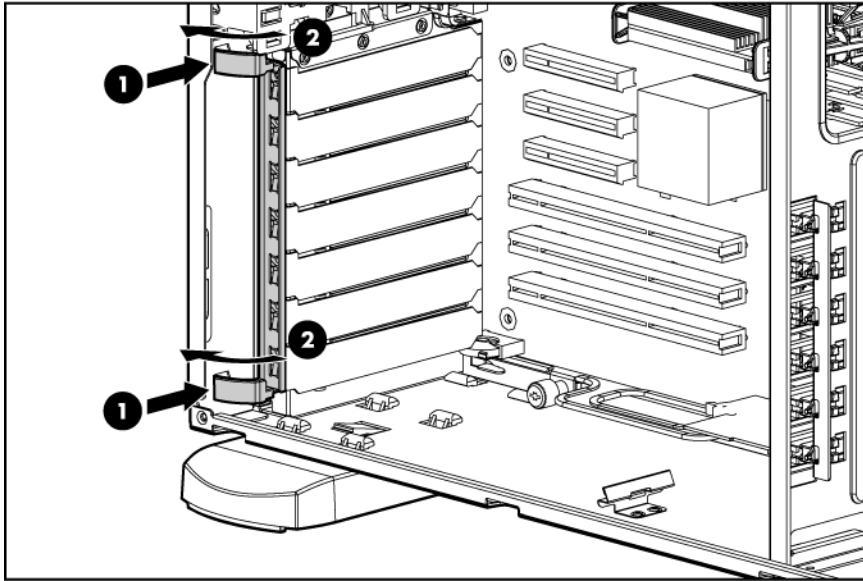

- 6. Install the expansion board.



IMPORTANT: Be sure to install expansion boards in the appropriate type of expansion slot. Most 32-bit expansion boards can be installed in a 64-bit PCI-X slot. However, PCI Express expansion boards must be installed in PCI Express expansion slots only.

PCI-X video cards must be installed in slots 2 or 3 only.

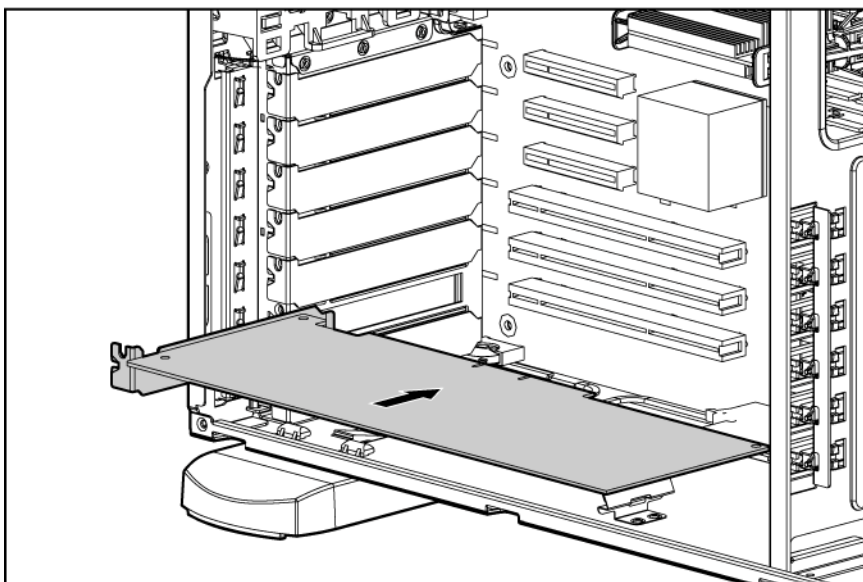

7. Close the expansion slot latch to secure the board.
8. Connect any required internal cables to the expansion board. Refer to the documentation that ships with the expansion board.
9. Install the expansion board retainer.
10. Install the access panel (on page 20).
11. Do one of the following:
 - o Close or install the tower bezel, as needed.
 - o Slide the server back into the rack.
12. Connect any required external cables to the expansion board. Refer to the documentation that ships with the expansion board.

Parallel and second serial connector option

To install the component:

1. Power down the server (on page 17).
2. Do one of the following:
 - o Open or remove the tower bezel, as needed ("[Open or remove the tower bezel](#)" on page 18).
 - o Extend the server from the rack (on page 17).
3. Remove the access panel (on page 19).
4. Remove an expansion slot cover ("[Removing the expansion slot cover](#)" on page 48).
5. Install the parallel and serial connector bracket and close the slot cover.
6. Connect the parallel and serial cables to the parallel and serial connectors on the system board.

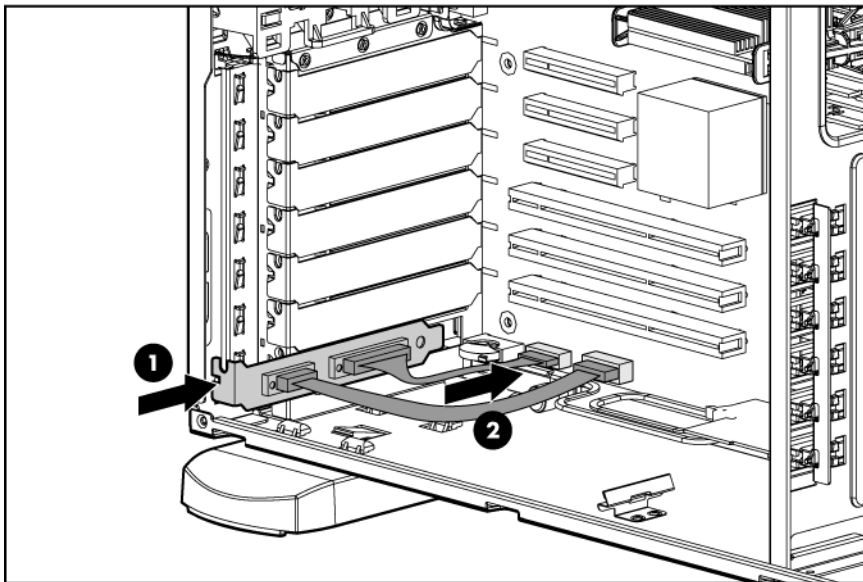

7. Install the access panel (on page 20).
8. Do one of the following:
 - o Close or install the tower bezel, as needed.
 - o Slide the server back into the rack.
9. Power up the server (on page 17).

10. Enable the feature under the System Options menu in RBSU. For more information on RBSU, refer to the *HP ROM-Based Setup Utility User Guide* on the Documentation CD or the HP website (<http://www.hp.com/servers/smartstart>).

PCI-X expansion cage option

The PCI-X expansion cage option converts one PCI Express slot into two PCI-X slots for additional expansion board capability. The PCI-X expansion cage does not support expansion boards with internal cabling requirements.

After installing the PCI-X expansion cage, run RBSU and enable the Optional PCI-X Riser Fan Monitoring setting from the Advanced Options menu. Enabling this option provides health monitoring of the riser fans which appear as fans 7 and 8. In addition, both expansion boards installed in the PCI-X expansion cage appear as slot 6.



IMPORTANT: The following conditions apply for the PCI-X expansion cage:

- Only one HP Smart Array controller can be installed in the PCI-X expansion cage at one time.
 - Only one HP Single-channel U320 storage controller can be installed in the PCI-X expansion cage at one time.
 - An HP Smart Array controller and an HP Single-channel U320 storage controller cannot both be installed in the PCI-X expansion cage at the same time.
-

To install the component:



CAUTION: To prevent damage to the server or expansion boards, power down the server and remove all AC power cords before removing or installing the PCI-X expansion cage.

1. Power down the server (on page 17).
2. Do one of the following:
 - Open or remove the tower bezel, as needed ("[Open or remove the tower bezel](#)" on page 18).
 - Remove the server from the rack (on page 18).
3. Remove the access panel (on page 19).

4. Remove the two T-15 screws from the rear panel using the T-10/T-15 Torx screwdriver, and then remove the rear access panel. Retain the screws for securing the PCI-X expansion cage.

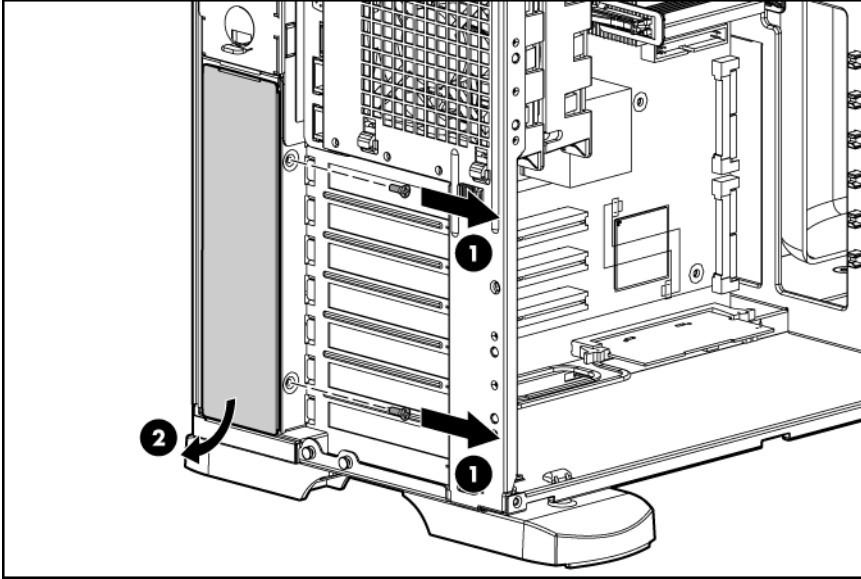

5. Remove the airflow shield from the chassis. Retain the shield for future use if the PCI-X expansion cage is not installed.

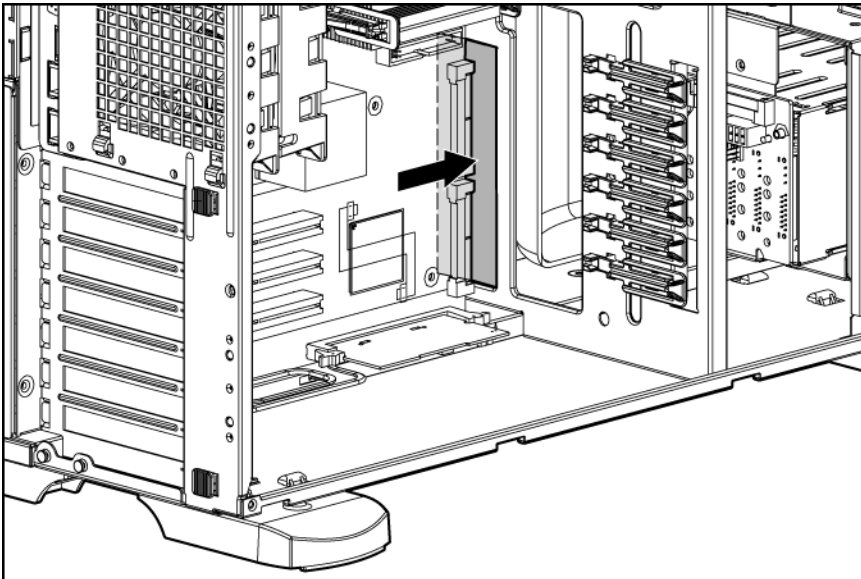

6. Remove the four T-15 screws from the hard drive cage, and then slide the hard drive cage partially out of the chassis.

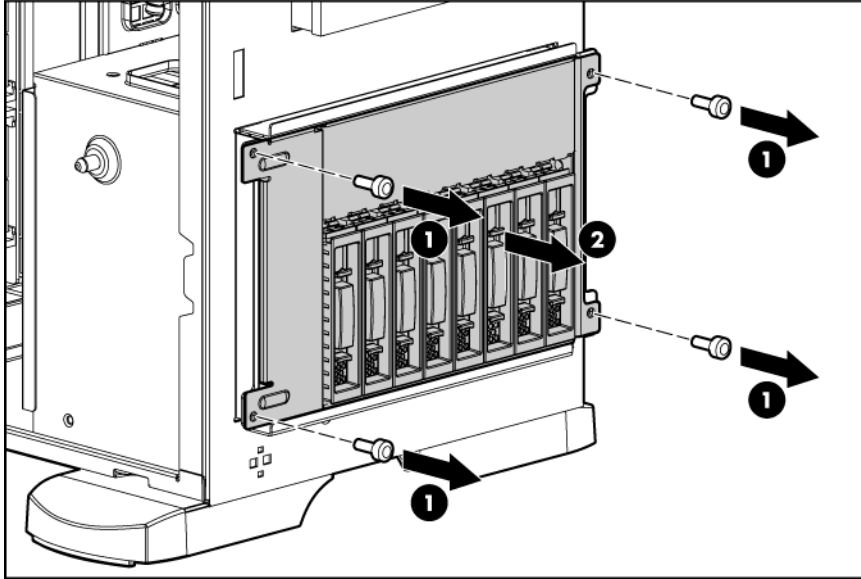

7. Pull the spring-loaded locking pin out, and then turn one-quarter turn to an extended position.

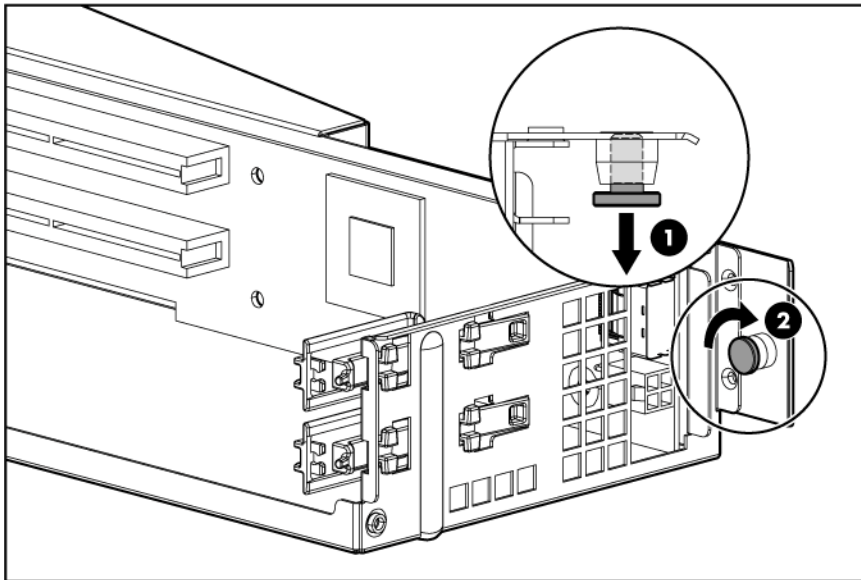

8. Remove a PCI-X expansion slot cover.

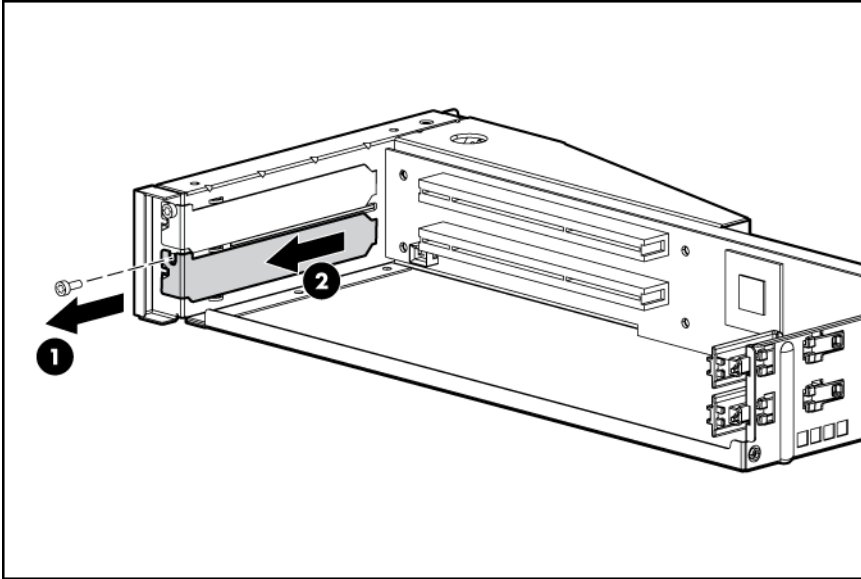

9. Install PCI-X expansion boards in the PCI-X expansion cage.

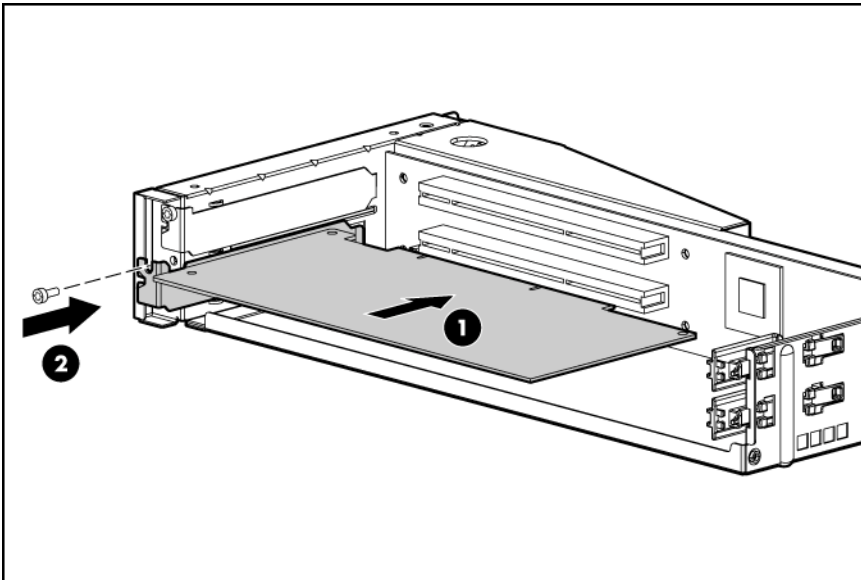

10. Install the PCI-X expansion cage. Secure the assembly with the screws from the rear access panel.

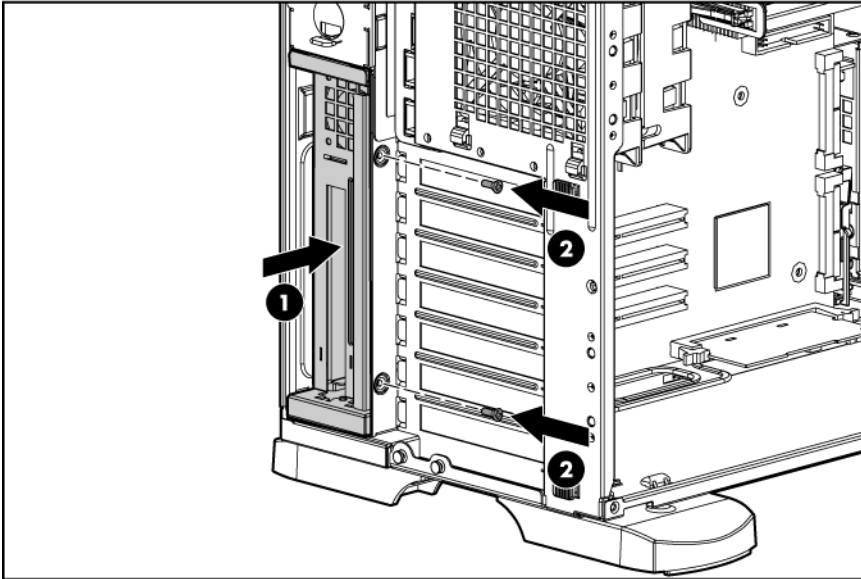

11. Turn the spring-loaded locking pin until it locks into the chassis.

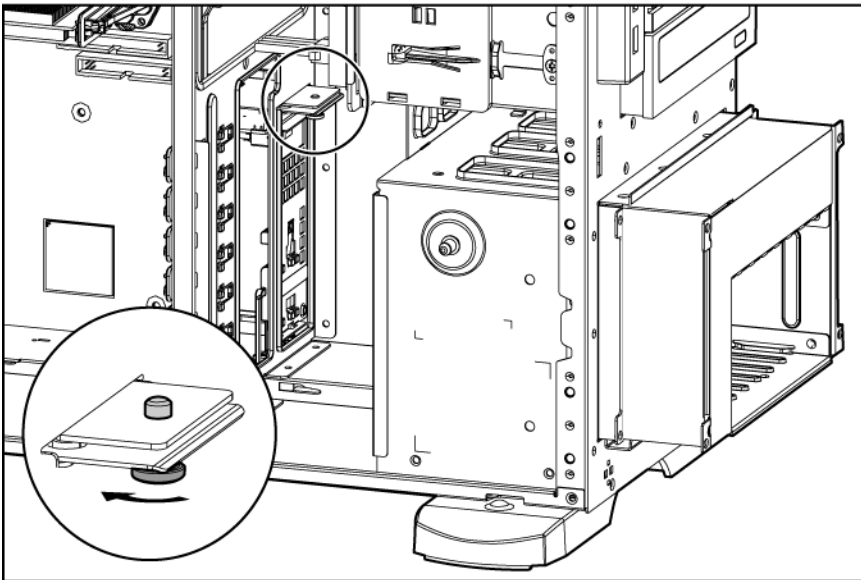

12. Remove the expansion board or the expansion slot cover for expansion slot 6. The PCI-X expansion cage is supported only by slot 6.
13. Install the included PCI Express conversion card into expansion slot 6.

NOTE: With the PCI-X expansion cage option, the additional PCI-X slots are recognized as slot 6 by the ROM.

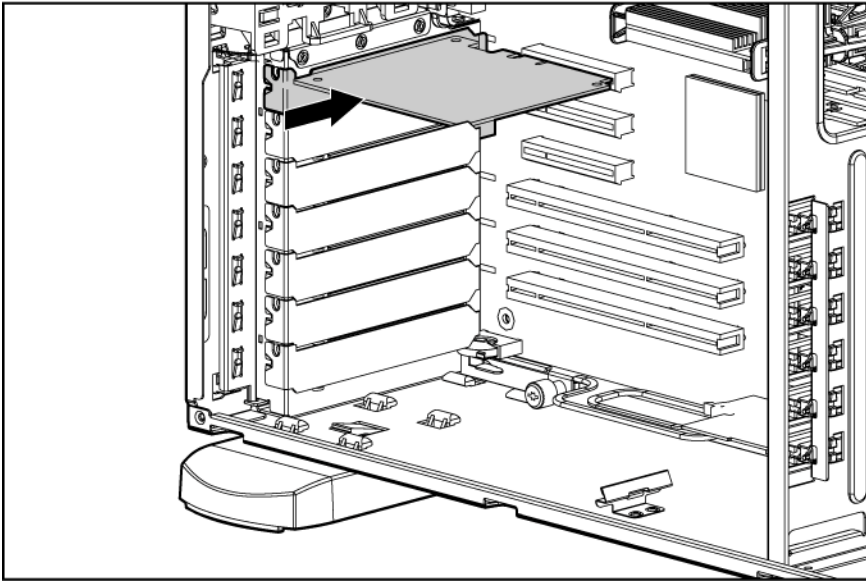

14. Connect the signal cable to the installed PCI Express conversion card and to the PCI-X expansion cage.

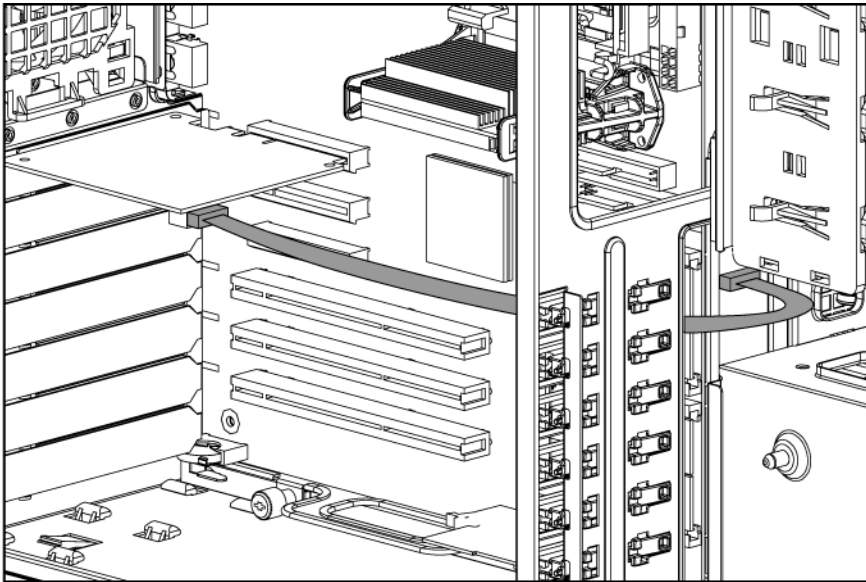

15. Disconnect the first power connector of both system power cables from any installed media bay devices.
16. Connect the included power cable extension:
 - a. Connect the extension to the PCI-X expansion cage.

- b. Connect the extension to the first power connector of both system power cables.

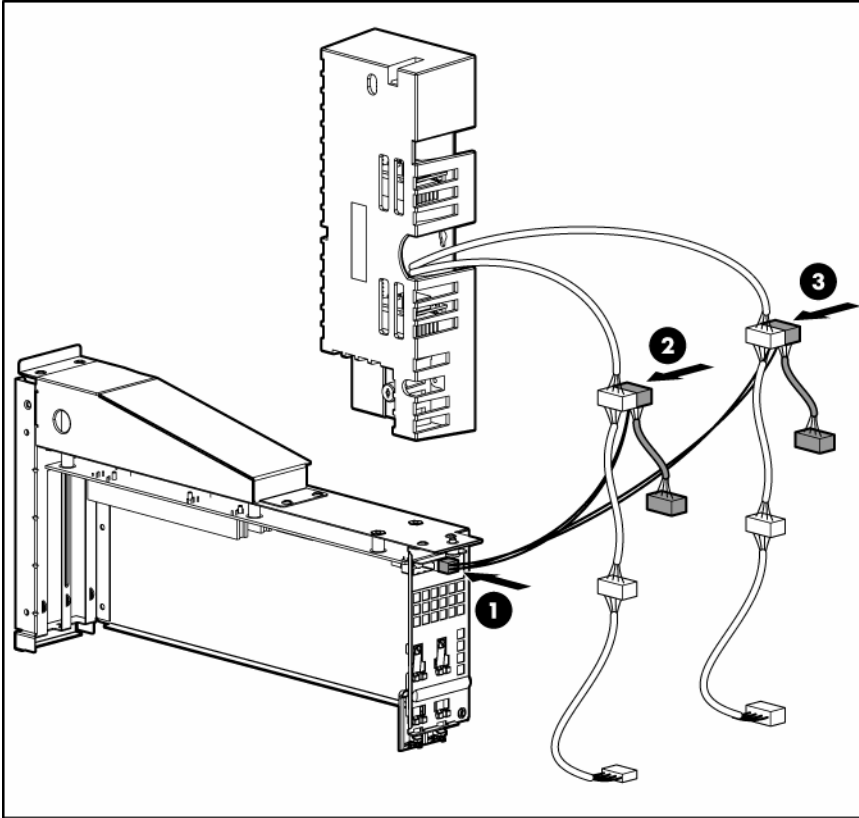

17. Connect the power connectors on the power cable extension to any installed media bay devices. Route the unused portion of the system power cables to avoid airflow restriction.
18. Install any other expansion boards ("[Installing an expansion board](#)" on page 49).
19. Slide the hard drive cage back into the chassis, and then secure the cage with the four T-15 screws.

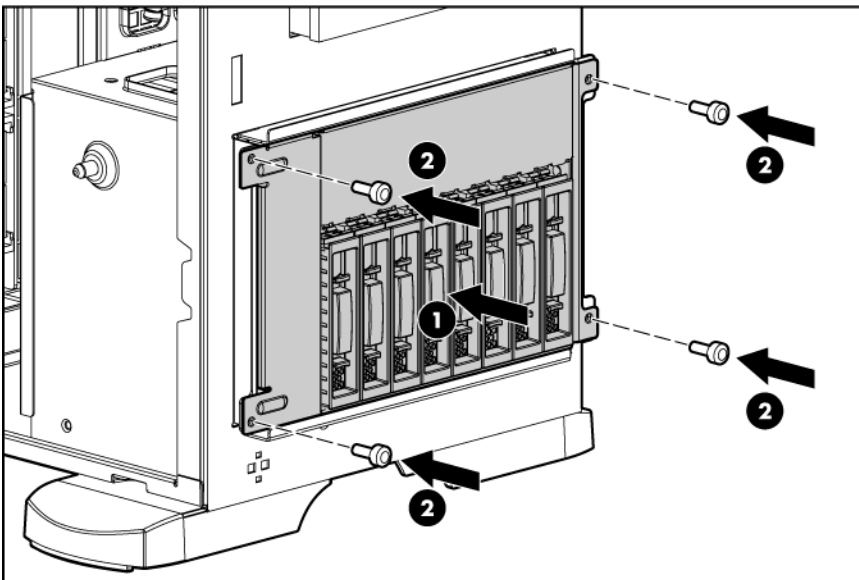

20. Install the access panel (on page 20).
21. Do one of the following:
- o Close or install the tower bezel, as needed.

- Install the server in the rack.
- 22. Connect any external cables to the PCI-X expansion boards.
- 23. Power up the server (on page 17).
- 24. Run RBSU and enable the Optional PCI-X Riser Fan Monitoring setting. Enabling this option provides health monitoring of the riser fans ("ROM-Based Setup Utility" on page 68).

Redundant fan assembly option

The server supports redundant fans to provide proper airflow to the system if a primary fan fails.

In the standard, non-redundant, configuration, fans 1 and 2 cool the server.

For the redundant configuration, fans 3 and 4 are added to back up the primary fans. This configuration enables the server to continue operation in non-redundant mode, if a fan failure occurs. The following rules apply:

- If one fan fails in non-redundant mode, the server shuts down.
- If one fan fails in redundant mode, the server converts to non-redundant mode.
- If two fans fail in redundant mode, the server shuts down.

To install the component:

1. Power down the server (on page 17).
2. Do one of the following:
 - Open or remove the tower bezel, as needed ("Open or remove the tower bezel" on page 18).
 - Extend the server from the rack (on page 17).
3. Remove the access panel (on page 19).
4. Remove the air baffle.

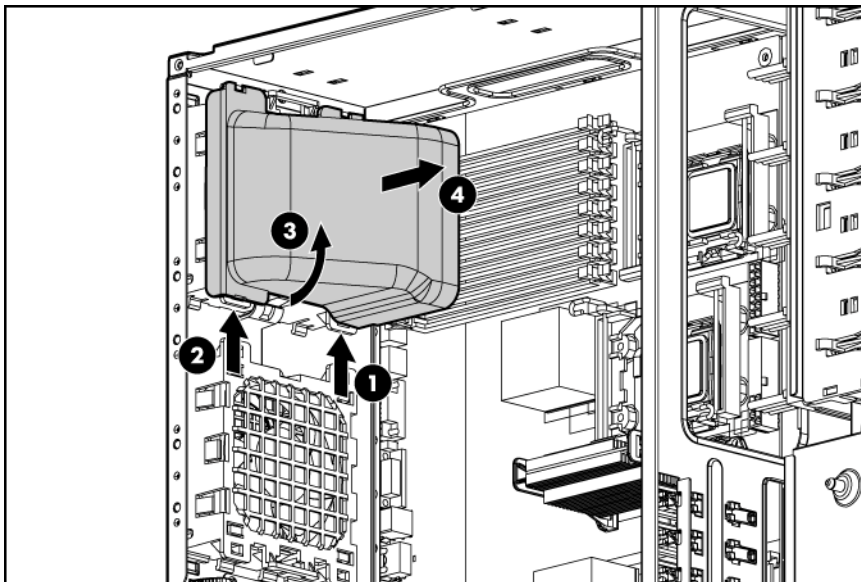

5. Install the redundant fan assembly, making sure the fans click into place.

NOTE: The fan configuration is redundant only when both fans are installed.

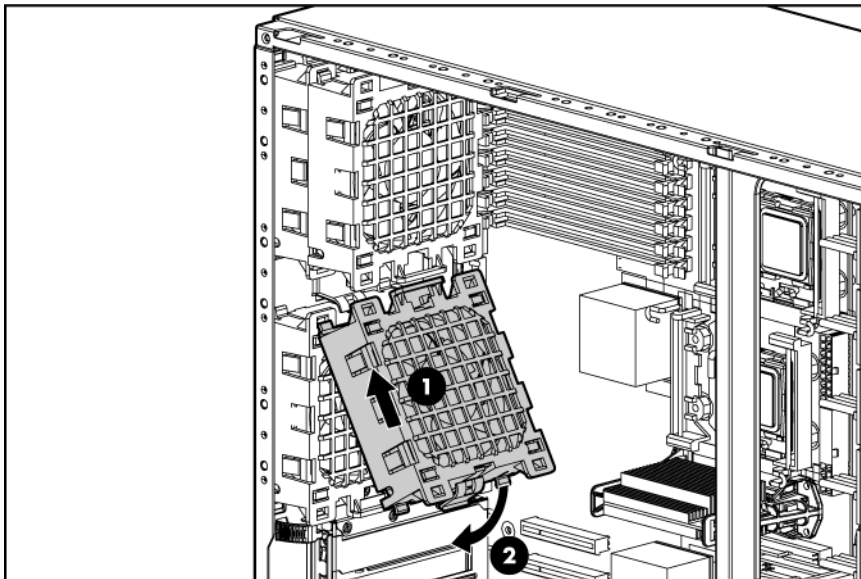
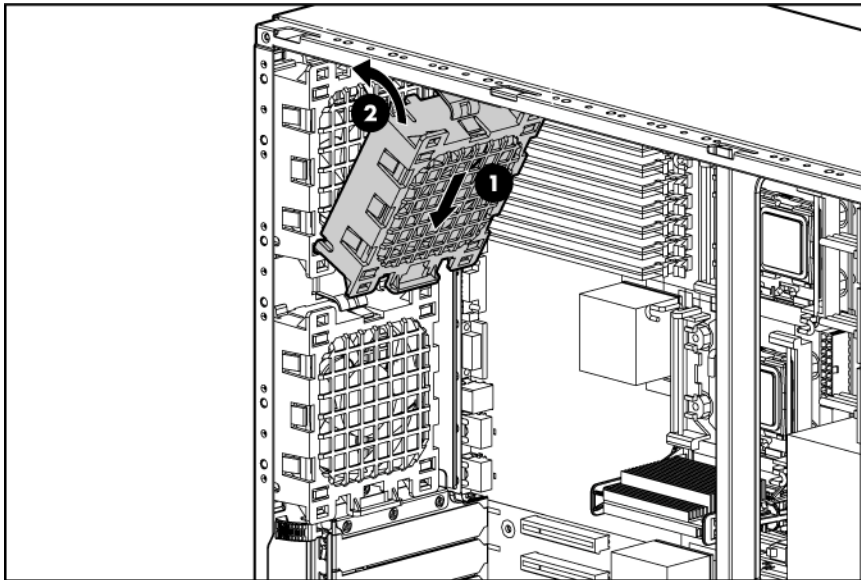

6. Connect the redundant fan cables to the redundant fan connectors on the system board ("[System board components](#)" on page [11](#)).
7. Install the air baffle.
8. Install the access panel (on page [20](#)).
9. Do one of the following:
 - o Close or install the tower bezel, as needed.
 - o Slide the server back into the rack.
10. Power up the server (on page [17](#)).

Battery-backed write cache option

The server supports multiple memory modules and RAID levels:

- 64 MB supports RAID 0, 1, 10

- 128 MB supports RAID 0, 1, 5, and 10



CAUTION: To prevent a server malfunction or damage to the equipment, do not add or remove the battery pack while an array capacity expansion, RAID level migration, or stripe size migration is in progress.



IMPORTANT: The battery pack might have a low charge when installed. In this case, a POST error message is displayed when the server is powered up, indicating that the battery pack is temporarily disabled. No action is necessary on your part. The internal circuitry automatically recharges the batteries and enables the battery pack. This process might take up to four hours. During this time, the cache module functions properly, but without the performance advantage of the battery pack.

NOTE: The data protection and the time limit also apply if a power outage occurs. When power is restored to the system, an initialization process writes the preserved data to the hard drives.

To install the component:

1. Power down the server (on page 17).
2. Do one of the following:
 - Open or remove the tower bezel, as needed ("[Open or remove the tower bezel](#)" on page 18).
 - Extend the server from the rack (on page 17).
3. Remove the access panel (on page 19).
4. Install the cache module with integrated battery pack.

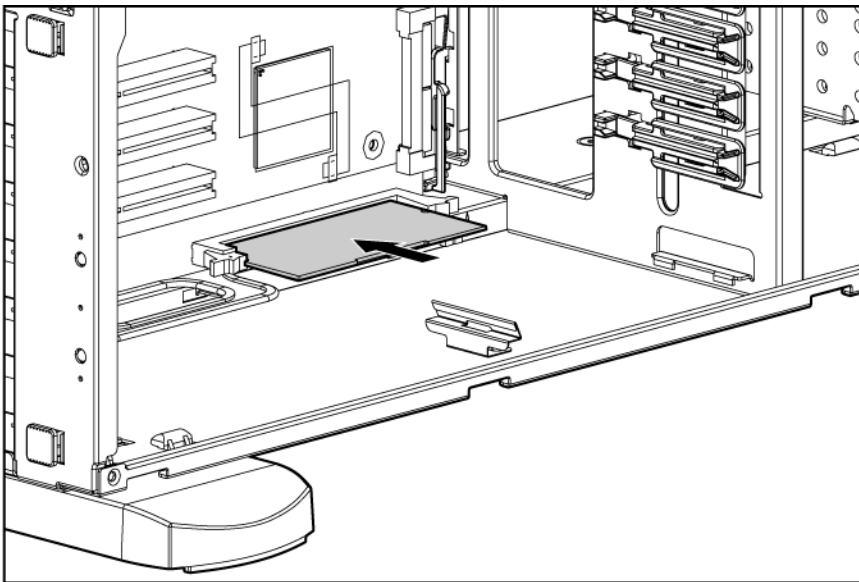

5. Install the access panel (on page 20).
6. Do one of the following:
 - Close or install the tower bezel, as needed.
 - Slide the server back into the rack.
7. Power up the server (on page 17).

Refer to the option documentation for more information.

Tower-to-rack conversion option

The tower-to-rack conversion kit includes all equipment required to convert the tower model server into a rack model server and to install the server into most square- or round-hole racks.

The tower-to-rack conversion kit includes:

- Rack rails
- Cable management arm
- Server rails
- Cage nuts
- Rack bezel
- Cable management arm extender bracket, included with the server

In addition to the supplied items, you may need:

- T-10 Torx screwdriver
- T-15 Torx screwdriver

To convert a tower server to a rack server:

1. Power down the server (on page 17).
2. Remove the tower bezel ("[Open or remove the tower bezel](#)" on page 18).
3. Remove the feet.

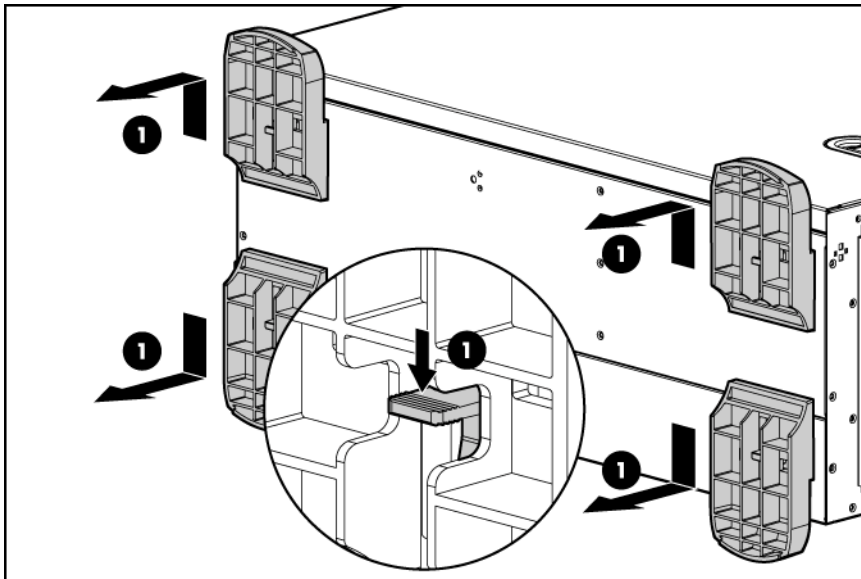

4. Remove both tower configuration panels.

Use the T-10 Torx screwdriver to remove the front panel screws. Unhook the tower configuration panels from the chassis, then slide them back and away from the chassis.

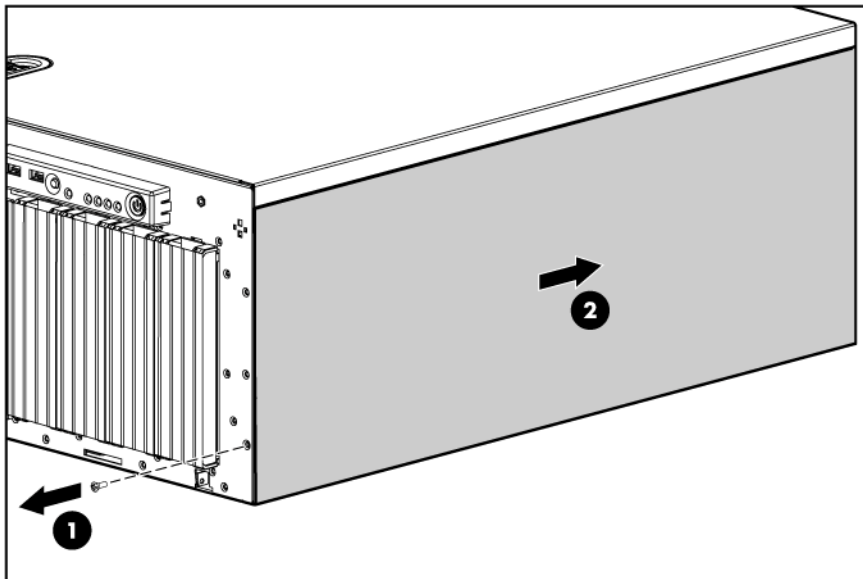
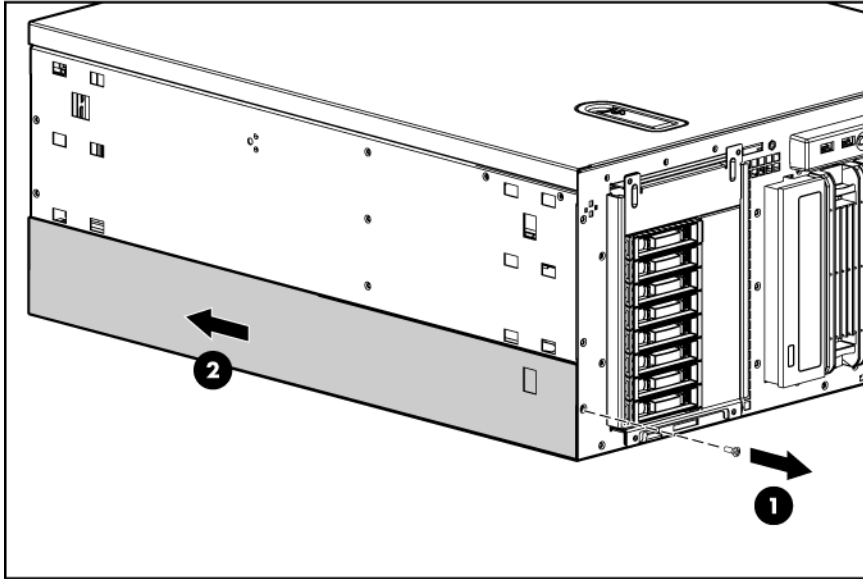

5. Remove the access panel (on page 19).

6. Align the pins on the rack bezel with the corresponding slots on the chassis, and secure the rack bezel to the chassis using the screws inside the chassis.

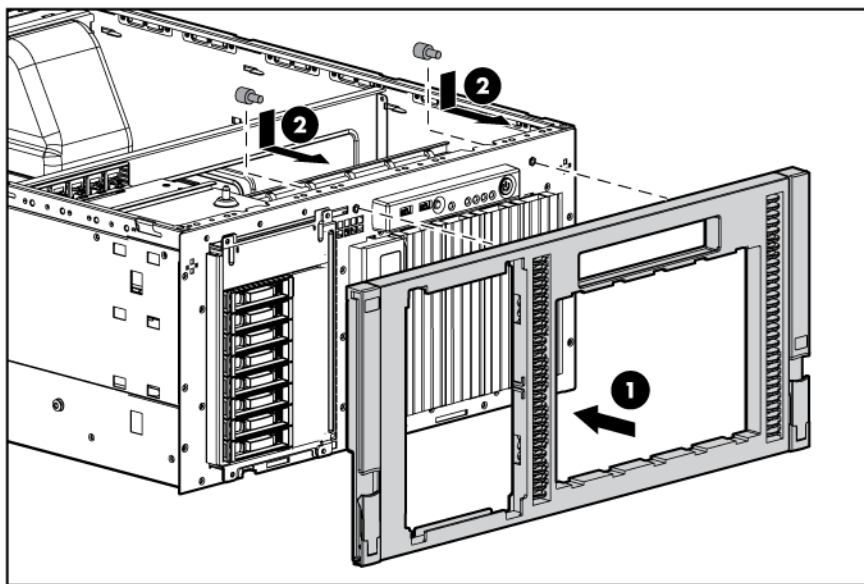

7. Install the access panel (on page 20).
8. Install the server into the rack ("[Installing the server into the rack](#)" on page 26).

Cabling

Optional SATA or SAS cabling

Many configurations are possible when SATA or SAS controllers are added. When upgrading the storage controller, refer to the Quickspecs and the cabling matrix to identify the correct cables (<http://h10010.www1.hp.com/wwpc/pscmisc/vac/us/en/ss/proliant/proliant-ml.html>).

Standard SATA hard drive cabling

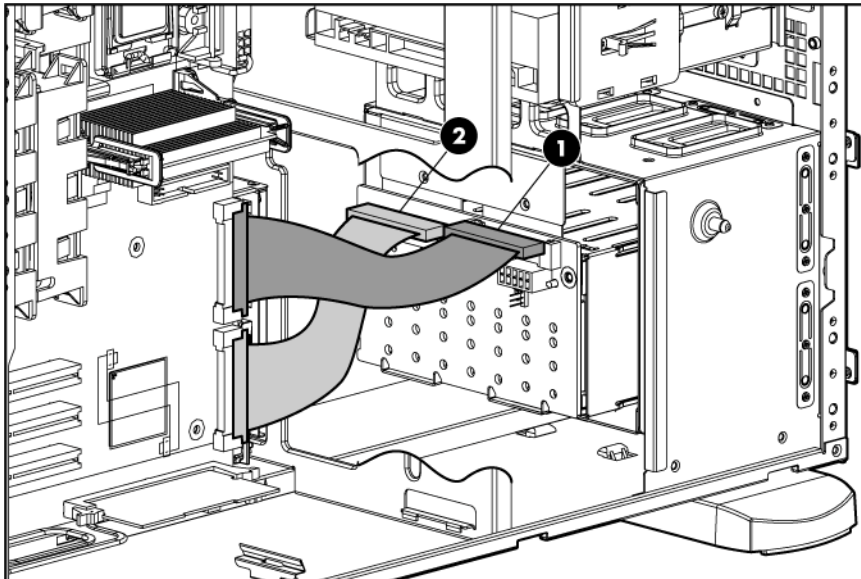

Item	Description
1	SATA cable (drives 1-4)
2	SATA cable (drives 5-8)

Optical drive cabling



IMPORTANT: If both SATA and PATA optical devices are installed simultaneously, only one can boot at a time. Boot priority will go to SATA if media is inserted into the SATA optical drive. Boot priority for PATA is not configurable. To boot PATA, remove the media from the SATA optical device, or remove the SATA optical device.

- PATA optical drive cabling

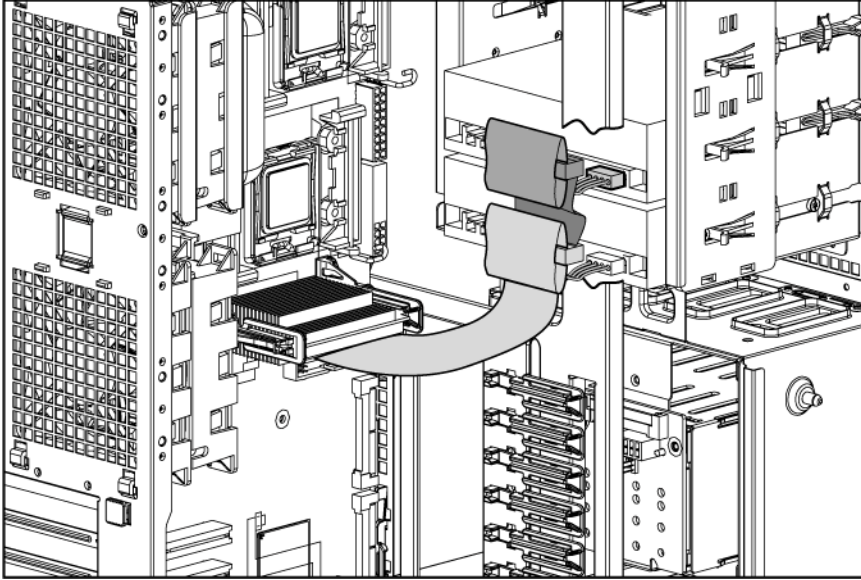

- SATA optical drive cabling

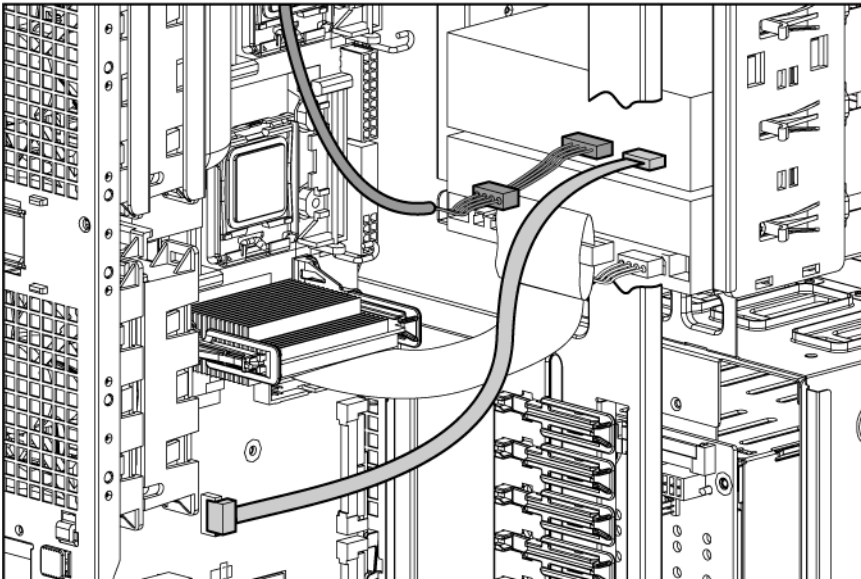

Optional ATA or ATAPI device cabling

This server includes one PATA cable (the Cable Select Cable) that can connect up to two ATA or ATAPI devices to the system through the integrated PATA controller. This cable has three clearly labeled connectors. If only one PATA device is connected to the system, it must be secured to the cable connector labeled Drive 0. For all PATA devices, set the configuration jumpers to "Cable Select" or "CS." ATA (PATA) hard drives are not supported.



IMPORTANT: If the network operating system is Novell NetWare, HP recommends that you connect the optical drive to the primary PATA channel and to the Drive 0 connector on the PATA cable.

Configuration and utilities

Configuration tools

SmartStart software

SmartStart is a collection of software that optimizes single-server setup, providing a simple and consistent way to deploy server configuration. SmartStart has been tested on many ProLiant server products, resulting in proven, reliable configurations.

SmartStart assists the deployment process by performing a wide range of configuration activities, including:

- Configuring hardware using embedded configuration utilities, such as RBSU and ORCA
- Preparing the system for installing "off-the-shelf" versions of leading operating system software
- Installing optimized server drivers, management agents, and utilities automatically with every assisted installation
- Testing server hardware using the Insight Diagnostics Utility ("HP Insight Diagnostics" on page 75)
- Installing software drivers directly from the CD. With systems that have internet connection, the SmartStart Autorun Menu provides access to a complete list of ProLiant system software.
- Enabling access to the Array Configuration Utility (on page 69), Array Diagnostic Utility (on page 74), and Erase Utility (on page 72)

SmartStart is included in the HP ProLiant Essentials Foundation Pack. For more information about SmartStart software, refer to the HP ProLiant Essentials Foundation Pack or the HP website (<http://h18013.www1.hp.com/products/servers/management/smartstart/index.html>).

SmartStart Scripting Toolkit

The SmartStart Scripting Toolkit is a server deployment product that delivers an unattended automated installation for high-volume server deployments. The SmartStart Scripting Toolkit is designed to support ProLiant BL, ML, and DL servers. The toolkit includes a modular set of utilities and important documentation that describes how to apply these new tools to build an automated server deployment process.

Using SmartStart technology, the Scripting Toolkit provides a flexible way to create standard server configuration scripts. These scripts are used to automate many of the manual steps in the server configuration process. This automated server configuration process cuts time from each server deployed, making it possible to scale server deployments to high volumes in a rapid manner.

For more information, and to download the SmartStart Scripting Toolkit, refer to the HP website (<http://www.hp.com/servers/sstoolkit>).

Configuration Replication Utility

CONREP is shipped in the SmartStart Scripting Toolkit and is a program that works with RBSU to replicate hardware configuration on ProLiant servers. This utility is run during State 0, Run Hardware Configuration Utility, when doing a scripted server deployment. CONREP reads the state of the system environment variables to determine the configuration and then writes the results to an editable script file. This file can then be deployed across multiple servers with similar hardware and software components. For more information, refer to the *SmartStart Scripting Toolkit User Guide* on the HP website (<http://h18004.www1.hp.com/products/servers/management/toolkit/documentation.html>).

ROM-Based Setup Utility

RBSU, an embedded configuration utility, performs a wide range of configuration activities that may include:

- Configuring system devices and installed options
- Displaying system information
- Selecting the primary boot controller

For more information on RBSU, see the *HP ROM-Based Setup Utility User Guide* on the Documentation CD or the HP website (<http://www.hp.com/support/smartstart/documentation>).

Using RBSU

To use RBSU, use the following keys:

- To access RBSU, press the **F9** key during power-up when prompted.
- To navigate the menu system, use the arrow keys.
- To make selections, press the **Enter** key.
- To access Help for a highlighted configuration option, press the **F1** key.



IMPORTANT: RBSU automatically saves settings when you press the **Enter** key. The utility does not prompt you for confirmation of settings before you exit the utility. To change a selected setting, you must select a different setting and press the **Enter** key.

Default configuration settings are applied to the server at one of the following times:

- Upon the first system power-up
- After defaults have been restored

Default configuration settings are sufficient for proper typical server operation, but configuration settings can be modified using RBSU. The system will prompt you for access to RBSU with each power-up.

Auto-configuration process

The auto-configuration process automatically runs when you boot the server for the first time. During the power-up sequence, the system ROM automatically configures the entire system without needing any intervention. During this process, the ORCA utility, in most cases, automatically configures the array to a default setting based on the number of drives connected to the server.

NOTE: The server may not support all the following examples.

NOTE: If the boot drive is not empty or has been written to in the past, ORCA does not automatically configure the array. You must run ORCA to configure the array settings.

Drives installed	Drives used	RAID level
1	1	RAID 0
2	2	RAID 1
3, 4, 5, or 6	3, 4, 5, or 6	RAID 5
More than 6	0	None

To change any ORCA default settings and override the auto-configuration process, press the **F8** key when prompted.

By default, the auto-configuration process configures the system for the English language. To change any default settings in the auto-configuration process (such as the settings for language, operating system, and primary boot controller), execute RBSU by pressing the **F9** key when prompted. After the settings are selected, exit RBSU and allow the server to reboot automatically.

For more information on RBSU, see the *HP ROM-Based Setup Utility User Guide* on the Documentation CD or the HP website (<http://www.hp.com/support/smartstart/documentation>).

Boot options

Near the end of the boot process, the boot options screen is displayed. This screen is visible for several seconds before the system attempts to boot from a diskette, CD, or hard drive. During this time, you can do the following:

- Access RBSU by pressing the **F9** key
- Access the System Maintenance Menu (which enables you to launch ROM-based Diagnostics or Inspect) by pressing the **F10** key
- Force a PXE Network boot by pressing the **F12** key

BIOS Serial Console

BIOS Serial Console allows you to configure the serial port to view POST error messages and run RBSU remotely through a serial connection to the server COM port. The server that you are remotely configuring does not require a keyboard and mouse.

For more information about BIOS Serial Console, see the *BIOS Serial Console User Guide* on the Documentation CD or the HP website (<http://www.hp.com/support/smartstart/documentation>).

Array Configuration Utility

The server supports multiple memory modules and RAID levels:

- 64 MB supports RAID 0, 1, 10
- 128 MB supports RAID 0, 1, 5, and 10

ACU is a browser-based utility with the following features:

- Runs as a local application or remote service

- Supports online array capacity expansion, logical drive extension, assignment of online spares, and RAID or stripe size migration
- Suggests the optimum configuration for an unconfigured system
- Provides different operating modes, enabling faster configuration or greater control over the configuration options
- Remains available any time that the server is on
- Displays on-screen tips for individual steps of a configuration procedure

For optimum performance, the minimum display settings are 800 × 600 resolution and 256 colors. Servers running Microsoft® operating systems require Internet Explorer 5.5 (with Service Pack 1) or later. For Linux servers, refer to the README.TXT file for additional browser and support information.

For more information, refer to the *Configuring Arrays on HP Smart Array Controllers Reference Guide* on the Documentation CD or the HP website (<http://www.hp.com>).

Option ROM Configuration for Arrays

Before installing an operating system, you can use the ORCA utility to create the first logical drive, assign RAID levels, and establish online spare configurations.

The utility also provides support for the following functions:

- Reconfiguring one or more logical drives
- Viewing the current logical drive configuration
- Deleting a logical drive configuration
- Setting the controller to be the boot controller

If you do not use the utility, ORCA will default to the standard configuration.

For more information regarding array controller configuration, refer to the controller user guide.

For more information regarding the default configurations that ORCA uses, refer to the *HP ROM-Based Setup Utility User Guide* on the Documentation CD.

HP ProLiant Essentials Rapid Deployment Pack

The RDP software is the preferred method for rapid, high-volume server deployments. The RDP software integrates two powerful products: Altiris Deployment Solution and the HP ProLiant Integration Module.

The intuitive graphical user interface of the Altiris Deployment Solution console provides simplified point-and-click and drag-and-drop operations that enable you to deploy target servers, including server blades, remotely. It enables you to perform imaging or scripting functions and maintain software images.

For more information about the RDP, refer to the HP ProLiant Essentials Rapid Deployment Pack CD or refer to the HP website (<http://www.hp.com/servers/rdp>).

Re-entering the server serial number and product ID

After you replace the system board, you must re-enter the server serial number and the product ID.

1. During the server startup sequence, press the **F9** key to access RBSU.
2. Select the **System Options** menu.

3. Select **Serial Number**. The following warning is displayed:
WARNING! WARNING! WARNING! The serial number is loaded into the system during the manufacturing process and should NOT be modified. This option should only be used by qualified service personnel. This value should always match the serial number sticker located on the chassis.
4. Press the **Enter** key to clear the warning.
5. Enter the serial number and press the **Enter** key.
6. Select **Product ID**.
7. Enter the product ID and press the **Enter** key.
8. Press the **Esc** key to close the menu.
9. Press the **Esc** key to exit RBSU.
10. Press the **F10** key to confirm exiting RBSU. The server will automatically reboot.

Management tools

Automatic Server Recovery

ASR is a feature that causes the system to restart when a catastrophic operating system error occurs, such as a blue screen, ABEND, or panic. A system fail-safe timer, the ASR timer, starts when the System Management driver, also known as the Health Driver, is loaded. When the operating system is functioning properly, the system periodically resets the timer. However, when the operating system fails, the timer expires and restarts the server.

ASR increases server availability by restarting the server within a specified time after a system hang or shutdown. At the same time, the HP SIM console notifies you by sending a message to a designated pager number that ASR has restarted the system. You can disable ASR from the HP SIM console or through RBSU.

ROMPaq utility

The ROMPaq utility enables you to upgrade the system firmware (BIOS) or Lights-Out 100 firmware. To upgrade the firmware, insert a ROMPaq diskette into the diskette drive or ROMPaq USB Key into an available USB port and boot the system.

The ROMPaq utility checks the system and provides a choice (if more than one exists) of available firmware revisions.

For more information about the ROMPaq utility, see the HP website (<http://www.hp.com/go/support>).

Integrated Lights-Out 2 technology

The iLO 2 subsystem is a standard component of selected ProLiant servers that provides server health and remote server manageability. The iLO 2 subsystem includes an intelligent microprocessor, secure memory, and a dedicated network interface. This design makes iLO 2 independent of the host server and its operating system. The iLO 2 subsystem provides remote access to any authorized network client, sends alerts, and provides other server management functions.

Using iLO 2, you can:

- Remotely power up, power down, or reboot the host server.

- Send alerts from iLO 2 regardless of the state of the host server.
- Access advanced troubleshooting features through the iLO 2 interface.
- Diagnose iLO 2 using HP SIM through a web browser and SNMP alerting.

For more information about iLO 2 features, refer to the iLO 2 documentation on the Documentation CD or on the HP website (<http://www.hp.com/servers/lights-out>).

System Online ROM flash component utility

The Online ROM Flash Component Utility enables system administrators to efficiently upgrade system or controller ROM images across a wide range of servers and array controllers. This tool has the following features:

- Works offline and online
- Supports Microsoft® Windows NT®, Windows® 2000, Windows Server™ 2003, Novell Netware, and Linux operating systems



IMPORTANT: This utility supports operating systems that may not be supported by the server. For operating systems supported by the server, see the HP website (<http://www.hp.com/support>).

- Integrates with other software maintenance, deployment, and operating system tools
- Automatically checks for hardware, firmware, and operating system dependencies, and installs only the correct ROM upgrades required by each target server

To download the tool and for more information, see the HP website (<http://www.hp.com/support>).

Erase Utility



CAUTION: Perform a backup before running the System Erase Utility. The utility sets the system to its original factory state, deletes the current hardware configuration information, including array setup and disk partitioning, and erases all connected hard drives completely. Refer to the instructions for using this utility.

Run the Erase Utility if you need to erase the system for the following reasons:

- You want to install a new operating system on a server with an existing operating system.
- You want to change the operating system selection.
- You encounter a failure-causing error during the SmartStart installation.
- You encounter an error when completing the steps of a factory-installed operating system installation.

The Erase Utility can be accessed from the Software and Drivers Download website (<http://www.hp.com/go/support>) or the **Maintenance Utilities** menu of the SmartStart CD ("SmartStart software" on page 67).

Management Agents

Management Agents provide the information to enable fault, performance, and configuration management. The agents allow easy manageability of the server through HP SIM software, and third-party SNMP management platforms. Management Agents are installed with every SmartStart assisted

installation or can be installed through the HP PSP. The Systems Management homepage provides status and direct access to in-depth subsystem information by accessing data reported through the Management Agents. For additional information, refer to the Management CD in the HP ProLiant Essentials Foundation Pack or the HP website (<http://www.hp.com/servers/manage>).

HP Systems Insight Manager

HP SIM is a web-based application that allows system administrators to accomplish normal administrative tasks from any remote location, using a web browser. HP SIM provides device management capabilities that consolidate and integrate management data from HP and third-party devices.



IMPORTANT: You must install and use HP SIM to benefit from the Pre-Failure Warranty for processors, SAS and SCSI hard drives, and memory modules.

For additional information, refer to the Management CD in the HP ProLiant Essentials Foundation Pack or the HP SIM website (<http://www.hp.com/go/hpsim>).

Redundant ROM support

The server enables you to upgrade or configure the ROM safely with redundant ROM support. The server has a 4-MB ROM that acts as two, separate 2-MB ROMs. In the standard implementation, one side of the ROM contains the current ROM program version, while the other side of the ROM contains a backup version.

NOTE: The server ships with the same version programmed on each side of the ROM.

Safety and security benefits

When you flash the system ROM, ROMPaq writes over the backup ROM and saves the current ROM as a backup, enabling you to switch easily to the alternate ROM version if the new ROM becomes corrupted for any reason. This feature protects the existing ROM version, even if you experience a power failure while flashing the ROM.

Access to redundant ROM settings

To access the redundant ROM through RBSU:

1. Access RBSU by pressing the **F9** key during powerup when the prompt is displayed in the upper right corner of the screen.
2. Select **Advanced Options**.
3. Select **Redundant ROM Selection**.
4. Select the ROM version.
5. Press the **Enter** key.
6. Press the **Esc** key to exit the current menu or press the **F10** key to exit RBSU. The server restarts automatically.

To access the redundant ROM manually:

1. Power down the server (on page 17).

2. Remove the access panel (on page 19).
3. Set positions 1, 5, and 6 of the system maintenance switch to On.
4. Install the access panel (on page 20).
5. Power up the server (on page 17).
6. Wait for the server to emit two beeps.
7. Repeat steps 1 and 2.
8. Set positions 1, 5, and 6 of the system maintenance switch to Off.
9. Repeat steps 4 and 5.

When the server boots, the system identifies whether the current ROM bank is corrupt. If a corrupt ROM is detected, the system boots from the backup ROM and alerts you through POST or IML that the ROM bank is corrupt.

If both the current and backup versions of the ROM are corrupt, the server automatically enters ROMPaq disaster recovery mode.

USB support

HP provides both standard USB support and legacy USB support. Standard support is provided by the operating system through the appropriate USB device drivers. HP provides support for USB devices before the operating system loads through legacy USB support, which is enabled by default in the system ROM. HP hardware supports USB version 1.1 or 2.0, depending on the version of the hardware.

Legacy USB support provides USB functionality in environments where USB support is normally not available. Specifically, HP provides legacy USB functionality for:

- POST
- RBSU
- Diagnostics
- DOS
- Operating environments which do not provide native USB support

For more information on ProLiant USB support, refer to the HP website (<http://h18004.www1.hp.com/products/servers/platforms/usb-support.html>).

Diagnostic tools

Array Diagnostic Utility

The HP Array Diagnostics Utility is a web-based application that creates a report of all HP storage controllers and disk drives. This report provides vital information to assist in identifying faults or conditions that may require attention. ADU can be accessed from the SmartStart CD ("SmartStart software" on page 67) or downloaded from the HP website (<http://www.hp.com>).

HP Insight Diagnostics

HP Insight Diagnostics is a proactive server management tool, available in both offline and online versions, that provides diagnostics and troubleshooting capabilities to assist IT administrators who verify server installations, troubleshoot problems, and perform repair validation.

HP Insight Diagnostics Offline Edition performs various in-depth system and component testing while the OS is not running. To run this utility, launch the SmartStart CD.

HP Insight Diagnostics Online Edition is a web-based application that captures system configuration and other related data needed for effective server management. Available in Microsoft® Windows® and Linux versions, the utility helps to ensure proper system operation.

For more information or to download the utility, refer to the HP website (<http://www.hp.com/servers/diags>).

Integrated Management Log

The IML records hundreds of events and stores them in an easy-to-view form. The IML timestamps each event with 1-minute granularity.

You can view recorded events in the IML in several ways, including the following:

- From within HP SIM ("HP Systems Insight Manager" on page 73)
- From within Survey Utility
- From within operating system-specific IML viewers
 - For NetWare: IML Viewer
 - For Windows®: IML Viewer
 - For Linux: IML Viewer Application
- From within the iLO 2 user interface
- From within HP Insight Diagnostics (on page 75)

For more information, refer to the Management CD in the HP ProLiant Essentials Foundation Pack.

Keeping the system current

Drivers

The server includes new hardware that may not have driver support on all operating system installation media.

If you are installing a SmartStart-supported operating system, use the SmartStart software (on page 67) and its Assisted Path feature to install the operating system and latest driver support.

NOTE: If you are installing drivers from the SmartStart CD, be sure that you are using the latest version of SmartStart by visiting the SmartStart website (<http://www.hp.com/servers/smartstart>). For more information, refer to the documentation provided with the SmartStart CD.

If you do not use the SmartStart CD to install an operating system, drivers for some of the new hardware are required. These drivers, as well as other option drivers, ROM images, and value-add software can be downloaded from the HP website (<http://www.hp.com/support>).



IMPORTANT: Always perform a backup before installing or updating device drivers.

ProLiant Support Packs

PSPs represent operating system-specific bundles of ProLiant optimized drivers, utilities, and management agents. Refer to the PSP website (<http://h18000.www1.hp.com/products/servers/management/psp.html>).

Operating system version support

Refer to the operating system support matrix (<http://www.hp.com/go/supportos>).

Change control and proactive notification

HP offers Change Control and Proactive Notification to notify customers 30 to 60 days in advance of upcoming hardware and software changes on HP commercial products.

For more information, refer to the HP website (<http://www.hp.com/go/pcn>).

Care Pack

HP Care Pack Services offer upgraded service levels to extend and expand standard product warranty with easy-to-buy, easy-to-use support packages that help you make the most of your server investments. Refer to the Care Pack website (http://www.hp.com/hps/carepack/servers/cp_proliant.html).

Troubleshooting

Troubleshooting resources

The *HP ProLiant Servers Troubleshooting Guide* provides simple procedures for resolving common problems as well as a comprehensive course of action for fault isolation and identification, error message interpretation, issue resolution, and software maintenance.

To obtain the guide, refer to any of the following sources and then select the *HP ProLiant Servers Troubleshooting Guide*:

- The server-specific Documentation CD
- The Business Support Center on the HP website (<http://www.hp.com/support>). Navigate to the server technical support page. Under self-help resources, select **ProLiant Troubleshooting Guide**.
- The Technical Documentation website (<http://www.docs.hp.com>). Select **Enterprise Servers, Workstations and Systems Hardware**, and then the appropriate server.

Pre-diagnostic steps



WARNING: To avoid potential problems, ALWAYS read the warnings and cautionary information in the server documentation before removing, replacing, reseating, or modifying system components



IMPORTANT: This guide provides information for multiple servers. Some information may not apply to the server you are troubleshooting. Refer to the server documentation for information on procedures, hardware options, software tools, and operating systems supported by the server.

1. Review the important safety information (on page [77](#)).
2. Gather symptom information (on page [79](#)).
3. Prepare the server for diagnosis (on page [80](#)).
4. Use the Start diagnosis flowchart (on page [81](#)) to begin the diagnostic process.

Important safety information

Familiarize yourself with the safety information in the following sections before troubleshooting the server.



Important safety information

Before servicing this product, read the *Important Safety Information* document provided with the server.

Symbols on equipment

The following symbols may be placed on equipment to indicate the presence of potentially hazardous conditions.



This symbol indicates the presence of hazardous energy circuits or electric shock hazards. Refer all servicing to qualified personnel.

WARNING: To reduce the risk of injury from electric shock hazards, do not open this enclosure. Refer all maintenance, upgrades, and servicing to qualified personnel.



This symbol indicates the presence of electric shock hazards. The area contains no user or field serviceable parts. Do not open for any reason.

WARNING: To reduce the risk of injury from electric shock hazards, do not open this enclosure.



This symbol on an RJ-45 receptacle indicates a network interface connection.

WARNING: To reduce the risk of electric shock, fire, or damage to the equipment, do not plug telephone or telecommunications connectors into this receptacle.



This symbol indicates the presence of a hot surface or hot component. If this surface is contacted, the potential for injury exists.

WARNING: To reduce the risk of injury from a hot component, allow the surface to cool before touching.



27.22 kg
60 lb

This symbol indicates that the component exceeds the recommended weight for one individual to handle safely.

WARNING: To reduce the risk of personal injury or damage to the equipment, observe local occupational health and safety requirements and guidelines for manual material handling.



These symbols, on power supplies or systems, indicate that the equipment is supplied by multiple sources of power.

WARNING: To reduce the risk of injury from electric shock, remove all power cords to completely disconnect power from the system.

Warnings and cautions



WARNING: Only authorized technicians trained by HP should attempt to repair this equipment. All troubleshooting and repair procedures are detailed to allow only subassembly/module-level repair. Because of the complexity of the individual boards and subassemblies, no one should attempt to make repairs at the component level or to make modifications to any printed wiring board. Improper repairs can create a safety hazard.



WARNING: To reduce the risk of personal injury or damage to the equipment, be sure that:

- The leveling feet are extended to the floor.
 - The full weight of the rack rests on the leveling feet.
 - The stabilizing feet are attached to the rack if it is a single-rack installation.
 - The racks are coupled together in multiple-rack installations.
 - Only one component is extended at a time. A rack may become unstable if more than one component is extended for any reason.
-



WARNING: To reduce the risk of electric shock or damage to the equipment:

- Do not disable the power cord grounding plug. The grounding plug is an important safety feature.
 - Plug the power cord into a grounded (earthed) electrical outlet that is easily accessible at all times.
 - Unplug the power cord from the power supply to disconnect power to the equipment.
 - Do not route the power cord where it can be walked on or pinched by items placed against it. Pay particular attention to the plug, electrical outlet, and the point where the cord extends from the server.
-



27.22 kg

60 lb

WARNING: To reduce the risk of personal injury or damage to the equipment:

- Observe local occupation health and safety requirements and guidelines for manual handling.
 - Obtain adequate assistance to lift and stabilize the chassis during installation or removal.
 - The server is unstable when not fastened to the rails.
 - When mounting the server in a rack, remove the power supplies and any other removable module to reduce the overall weight of the product.
-



CAUTION: To properly ventilate the system, you must provide at least 7.6 cm (3.0 in) of clearance at the front and back of the server.



CAUTION: The server is designed to be electrically grounded (earthed). To ensure proper operation, plug the AC power cord into a properly grounded AC outlet only.

Symptom information

Before troubleshooting a server problem, collect the following information:

- What events preceded the failure? After which steps does the problem occur?
- What has been changed since the time the server was working?
- Did you recently add or remove hardware or software? If so, did you remember to change the appropriate settings in the server setup utility, if necessary?
- How long has the server exhibited problem symptoms?
- If the problem occurs randomly, what is the duration or frequency?

To answer these questions, the following information may be useful:

- Run HP Insight Diagnostics (on page 75) and use the survey page to view the current configuration or to compare it to previous configurations.
- Refer to your hardware and software records for information.
- Refer to server LEDs and their statuses.

Prepare the server for diagnosis

1. Be sure the server is in the proper operating environment with adequate power, air conditioning, and humidity control. Refer to the server documentation for required environmental conditions.
2. Record any error messages displayed by the system.
3. Remove all diskettes and CDs from the media drives.
4. Power down the server and peripheral devices if you will be diagnosing the server offline. Always perform an orderly shutdown, if possible. This means you must:
 - a. Exit any applications.
 - b. Exit the operating system.
 - c. Power down the server (on page 17).
5. Disconnect any peripheral devices not required for testing (any devices not necessary to power up the server). Do not disconnect the printer if you want to use it to print error messages.
6. Collect all tools and utilities, such as a Torx screwdriver, loopback adapters, ESD wrist strap, and software utilities, necessary to troubleshoot the problem.
 - You must have the appropriate Health Drivers and Management Agents installed on the server.

NOTE: To verify the server configuration, connect to the System Management homepage and select **Version Control Agent**. The VCA gives you a list of names and versions of all installed HP drivers, Management Agents, and utilities, and whether they are up to date.

- HP recommends you have access to the SmartStart CD for value-added software and drivers required during the troubleshooting process.
- HP recommends you have access to the server documentation for server-specific information.

Loose connections

Action:

- Be sure all power cords are securely connected.
- Be sure all cables are properly aligned and securely connected for all external and internal components.
- Remove and check all data and power cables for damage. Be sure no cables have bent pins or damaged connectors.
- If a fixed cable tray is available for the server, be sure the cords and cables connected to the server are routed correctly through the tray.
- Be sure each device is properly seated. Avoid bending or flexing circuit boards when reseating components.
- If a device has latches, be sure they are completely closed and locked.

- Check any interlock or interconnect LEDs that may indicate a component is not connected properly.
- If problems continue to occur, remove and reinstall each device, checking the connectors and sockets for bent pins or other damage.

Service notifications

To view the latest service notifications, refer to the HP website (<http://www.hp.com/go/bizsupport>). Select the appropriate server model, and then click the **Troubleshoot a Problem** link on the product page.

Troubleshooting flowcharts

To effectively troubleshoot a problem, HP recommends that you start with the first flowchart in this section, "Start diagnosis flowchart (on page 81)," and follow the appropriate diagnostic path. If the other flowcharts do not provide a troubleshooting solution, follow the diagnostic steps in "General diagnosis flowchart (on page 82)." The General diagnosis flowchart is a generic troubleshooting process to be used when the problem is not server-specific or is not easily categorized into the other flowcharts.

The available flowcharts include:

- Start diagnosis flowchart (on page 81)
- General diagnosis flowchart (on page 82)
- Server power-on problems flowchart (on page 84)
- POST problems flowchart (on page 87)
- OS boot problems flowchart (on page 88)
- Server fault indications flowchart (on page 90)

Start diagnosis flowchart

Use the following flowchart to start the diagnostic process.

Item	Refer to
1	"General diagnosis flowchart (on page 82)"
2	"Power-on problems flowchart ("Server power-on problems flowchart" on page 84)"
3	"POST problems flowchart (on page 87)"
4	"OS boot problems flowchart (on page 88)"
5	"Server fault indications flowchart (on page 90)"

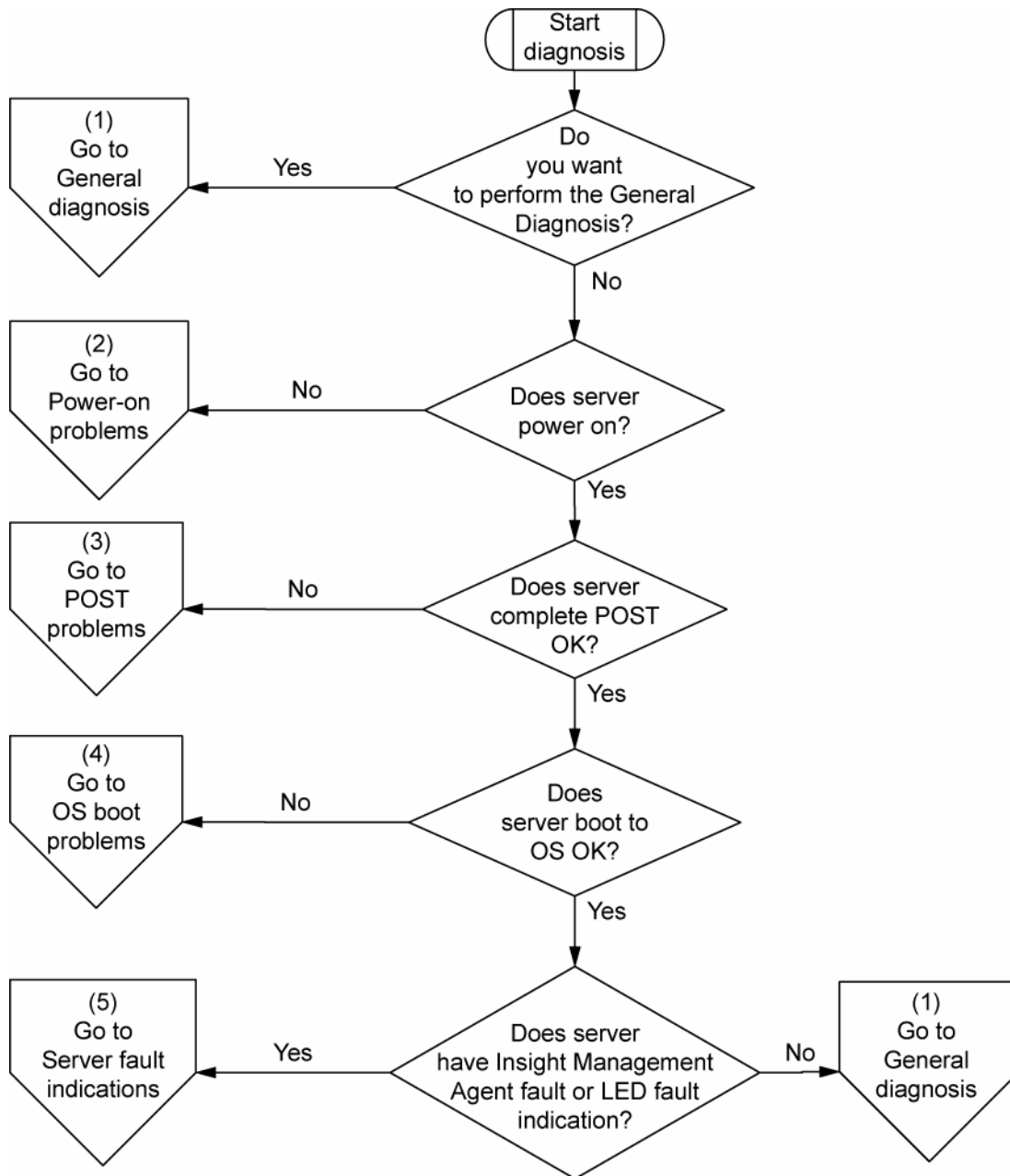

General diagnosis flowchart

The General diagnosis flowchart provides a generic approach to troubleshooting. If you are unsure of the problem, or if the other flowcharts do not fix the problem, use the following flowchart.

Item	Refer to
1	"Symptom information (on page 79)"
2	"Loose connections (on page 80)"
3	"Service notifications (on page 81)"

Item	Refer to
4	<p>The most recent version of a particular server or option firmware is available on the following websites:</p> <ul style="list-style-type: none"> • HP Support website (http://www.hp.com/support) • HP ROM-BIOS/Firmware Updates website (http://h18023.www1.hp.com/support/files/server/us/romflash.html)
5	<p>"General memory problems are occurring" in the <i>HP ProLiant Servers Troubleshooting Guide</i> located on the Documentation CD or on the HP website (http://www.hp.com/support)</p>
6	<p>Server maintenance and service guide, located on the Documentation CD or the HP website (http://www.hp.com/products/servers/platforms)</p>
7	<ul style="list-style-type: none"> • Server maintenance and service guide, located on the Documentation CD or the HP website (http://www.hp.com/products/servers/platforms) • "Hardware problems" in the <i>HP ProLiant Servers Troubleshooting Guide</i> located on the Documentation CD or on the HP website (http://www.hp.com/support)
8	<ul style="list-style-type: none"> • "Server information you need" in the <i>HP ProLiant Servers Troubleshooting Guide</i> located on the Documentation CD or on the HP website (http://www.hp.com/support) • "Operating system information you need" in the <i>HP ProLiant Servers Troubleshooting Guide</i> located on the Documentation CD or on the HP website (http://www.hp.com/support)
9	<p>"HP contact information (on page 105)"</p>

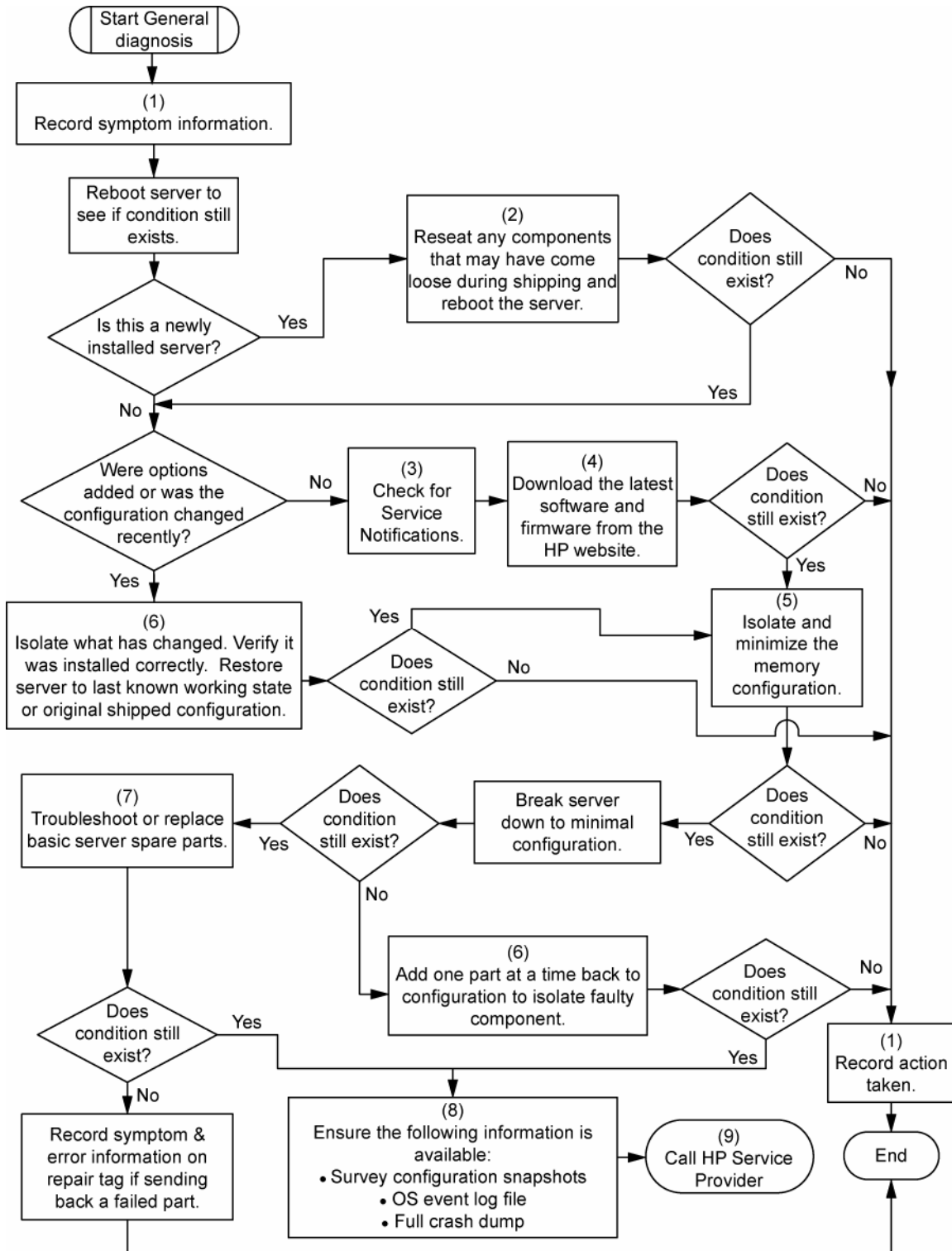

Server power-on problems flowchart

Symptoms:

- The server does not power on.
- The system power LED is off or amber.

- The external health LED is red or amber.
- The internal health LED is red or amber.

NOTE: For the location of server LEDs and information on their statuses, refer to the server documentation.

Possible causes:

- Improperly seated or faulty power supply
- Loose or faulty power cord
- Power source problem
- Power on circuit problem
- Improperly seated component or interlock problem
- Faulty internal component

Item	Refer to
1	"Component identification (on page 7)"
2	"HP Insight Diagnostics (on page 75)" or in the <i>HP ProLiant Servers Troubleshooting Guide</i> located on the Documentation CD or on the HP website (http://www.hp.com/support)
3	"Loose connections (on page 80)"
4	Server maintenance and service guide, located on the Documentation CD, or the HP website (http://www.hp.com/products/servers/platforms)
5	"Integrated Management Log (on page 75)" or in the <i>HP ProLiant Servers Troubleshooting Guide</i> located on the Documentation CD or on the HP website (http://www.hp.com/support)
6	"Power source problems" in the <i>HP ProLiant Servers Troubleshooting Guide</i> located on the Documentation CD or on the HP website (http://www.hp.com/support)
7	<ul style="list-style-type: none"> • "Power supply problems" in the <i>HP ProLiant Servers Troubleshooting Guide</i> located on the Documentation CD or on the HP website (http://www.hp.com/support) • Server maintenance and service guide, located on the Documentation CD, or the HP website (http://www.hp.com/products/servers/platforms)
8	"System open circuits and short circuits" in the <i>HP ProLiant Servers Troubleshooting Guide</i> located on the Documentation CD or on the HP website (http://www.hp.com/support)

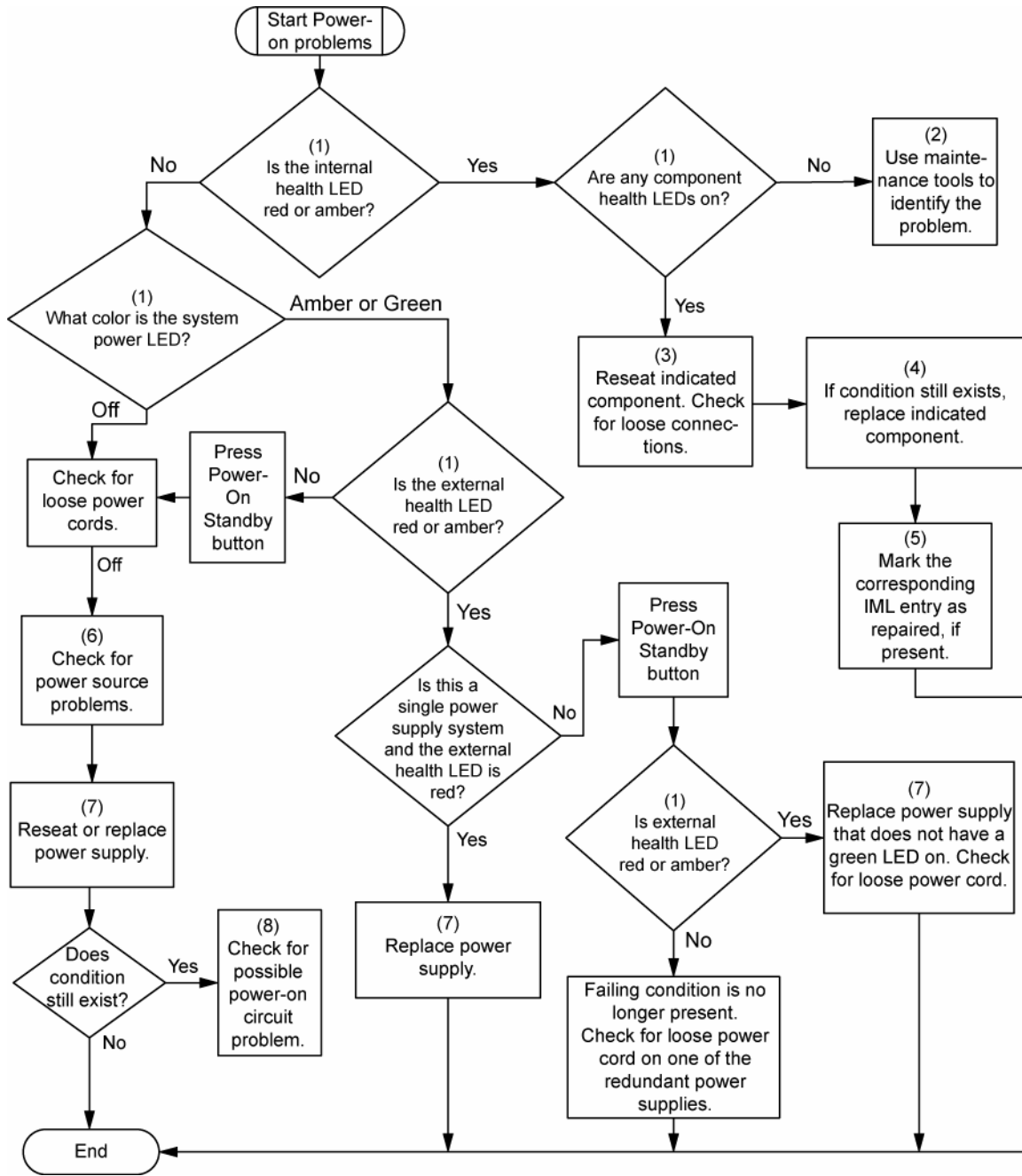

POST problems flowchart

Symptoms:

- Server does not complete POST

NOTE: The server has completed POST when the system attempts to access the boot device.

- Server completes POST with errors

Possible problems:

- Improperly seated or faulty internal component
- Faulty KVM device
- Faulty video device

Item	Refer to
1	"POST error messages and beep codes (on page 92)"
2	"Video problems" in the <i>HP ProLiant Servers Troubleshooting Guide</i> located on the Documentation CD or on the HP website (http://www.hp.com/support)
3	KVM or iLO 2 documentation
4	"Loose connections (on page 80)"
5	"Symptom information (on page 79)"
6	Server maintenance and service guide, located on the Documentation CD or the HP website (http://www.hp.com/products/servers/platforms)
7	"Port 85 and iLO messages" in the <i>HP ProLiant Servers Troubleshooting Guide</i> located on the Documentation CD or on the HP website (http://www.hp.com/support)
8	"General memory problems are occurring" in the <i>HP ProLiant Servers Troubleshooting Guide</i> located on the Documentation CD or on the HP website (http://www.hp.com/support)
9	<ul style="list-style-type: none"> • "Hardware problems" in the <i>HP ProLiant Servers Troubleshooting Guide</i> located on the Documentation CD or on the HP website (http://www.hp.com/support) • Server maintenance and service guide, located on the Documentation CD or the HP website (http://www.hp.com/products/servers/platforms)
10	<ul style="list-style-type: none"> • "Server information you need" in the <i>HP ProLiant Servers Troubleshooting Guide</i> located on the Documentation CD or on the HP website (http://www.hp.com/support) • "Operating system information you need" in the <i>HP ProLiant Servers Troubleshooting Guide</i> located on the Documentation CD or on the HP website (http://www.hp.com/support)

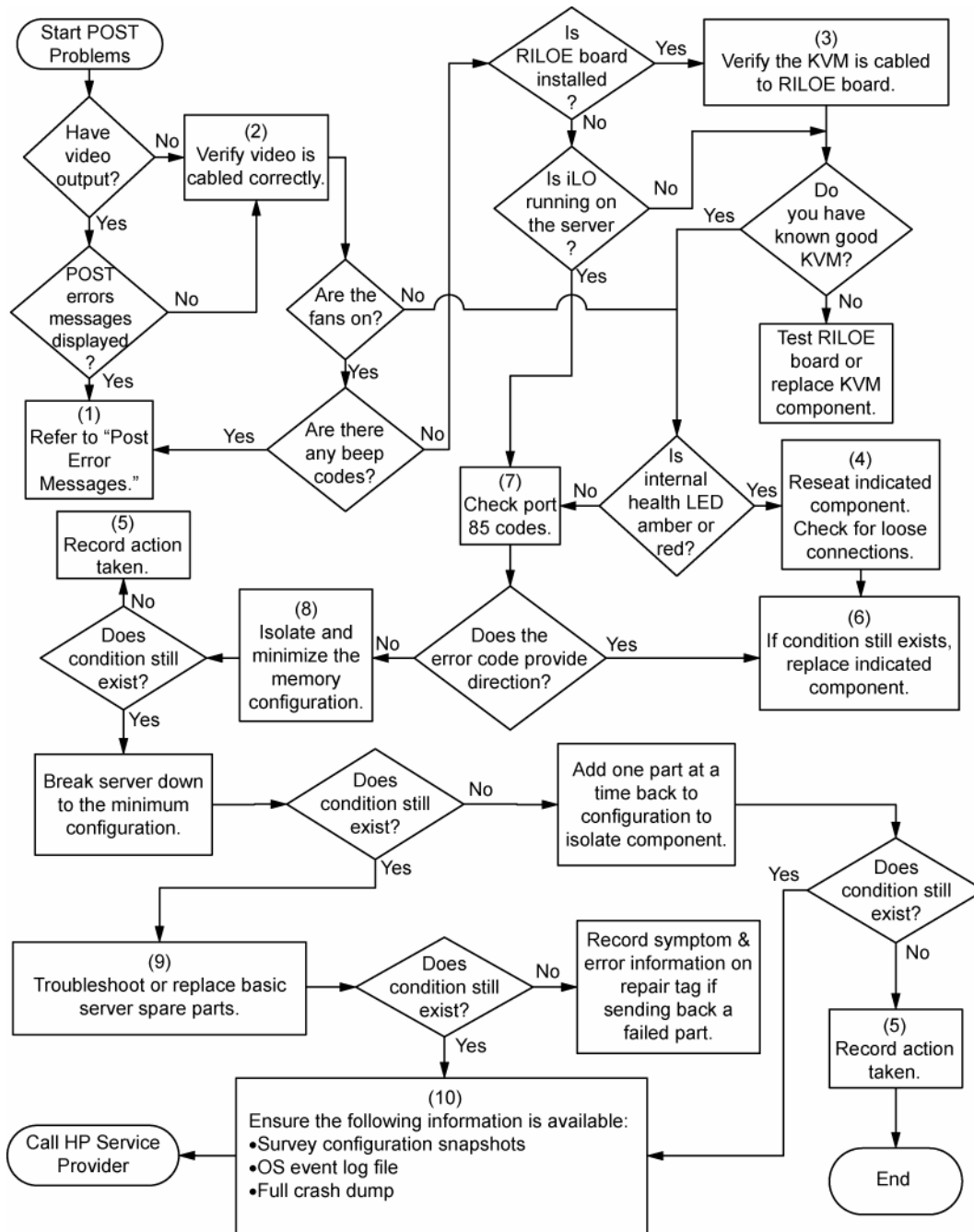

OS boot problems flowchart

Symptoms:

- Server does not boot a previously installed operating system
- Server does not boot SmartStart

Possible causes:

- Corrupted operating system
- Hard drive subsystem problem
- Incorrect boot order setting in RBSU

Item	Refer to
1	<p>HP ROM-Based Setup Utility User Guide http://www.hp.com/servers/smartstart</p>
2	<p>"POST problems flowchart (on page 87)"</p>
3	<ul style="list-style-type: none"> • "Hard drive problems" in the <i>HP ProLiant Servers Troubleshooting Guide</i> located on the Documentation CD or on the HP website (http://www.hp.com/support) • Controller documentation
4	<p>"HP Insight Diagnostics (on page 75)" or in the <i>HP ProLiant Servers Troubleshooting Guide</i> located on the Documentation CD or on the HP website (http://www.hp.com/support)</p>
5	<ul style="list-style-type: none"> • "CD-ROM and DVD drive problems" in the <i>HP ProLiant Servers Troubleshooting Guide</i> located on the Documentation CD or on the HP website (http://www.hp.com/support) • Controller documentation • "Loose connections (on page 80)"
6	<p>"General memory problems are occurring" in the <i>HP ProLiant Servers Troubleshooting Guide</i> located on the Documentation CD or on the HP website (http://www.hp.com/support)</p>
7	<ul style="list-style-type: none"> • "Operating system problems" in the <i>HP ProLiant Servers Troubleshooting Guide</i> located on the Documentation CD or on the HP website (http://www.hp.com/support) • "HP contact information (on page 105)"
8	<ul style="list-style-type: none"> • "Hardware problems" in the <i>HP ProLiant Servers Troubleshooting Guide</i> located on the Documentation CD or on the HP website (http://www.hp.com/support) • Server maintenance and service guide, located on the Documentation CD or the HP website (http://www.hp.com/products/servers/platforms)
9	<p>"General diagnosis flowchart (on page 82)"</p>

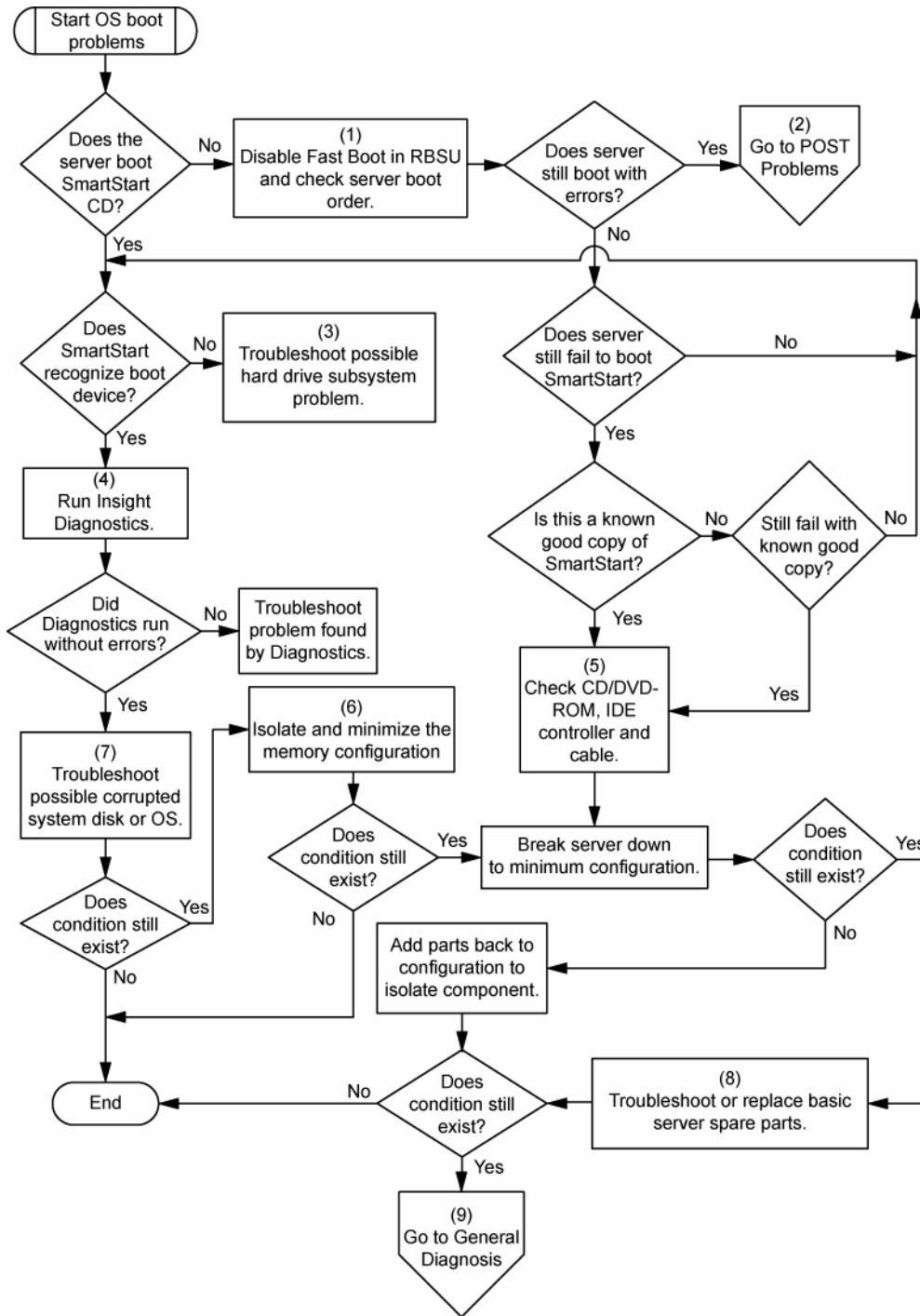

Server fault indications flowchart

Symptoms:

- Server boots, but a fault event is reported by Insight Management Agents (on page 72)
- Server boots, but the internal health LED, external health LED, or component health LED is red or amber

NOTE: For the location of server LEDs and information on their statuses, refer to the server documentation.

Possible causes:

- Improperly seated or faulty internal or external component
- Unsupported component installed
- Redundancy failure
- System overtemperature condition

Item	Refer to
1	"Management agents (on page 72)" or in the <i>HP ProLiant Servers Troubleshooting Guide</i> located on the Documentation CD or on the HP website (http://www.hp.com/support)
2	<ul style="list-style-type: none"> • "Integrated Management Log (on page 75)" or in the <i>HP ProLiant Servers Troubleshooting Guide</i> located on the Documentation CD or on the HP website (http://www.hp.com/support) • "Event list error messages" in the <i>HP ProLiant Servers Troubleshooting Guide</i> located on the Documentation CD or on the HP website (http://www.hp.com/support)
3	"Component identification (on page 7)"
4	System Management Homepage (https://localhost:2381)
5	"Power-on problems flowchart ("Server power-on problems flowchart" on page 84)"
6	<ul style="list-style-type: none"> • "Smart Array SCSI Diagnosis feature" in the <i>HP ProLiant Servers Troubleshooting Guide</i> located on the Documentation CD or on the HP website (http://www.hp.com/support) • Server maintenance and service guide, located on the Documentation CD or the HP website (http://www.hp.com/products/servers/platforms) • "HP contact information (on page 105)"
7	"HP Insight Diagnostics (on page 75)" or in the <i>HP ProLiant Servers Troubleshooting Guide</i> located on the Documentation CD or on the HP website (http://www.hp.com/support)
8	<ul style="list-style-type: none"> • "Hardware problems" in the <i>HP ProLiant Servers Troubleshooting Guide</i> located on the Documentation CD or on the HP website (http://www.hp.com/support) • Server maintenance and service guide, located on the Documentation CD or the HP website (http://www.hp.com/products/servers/platforms)

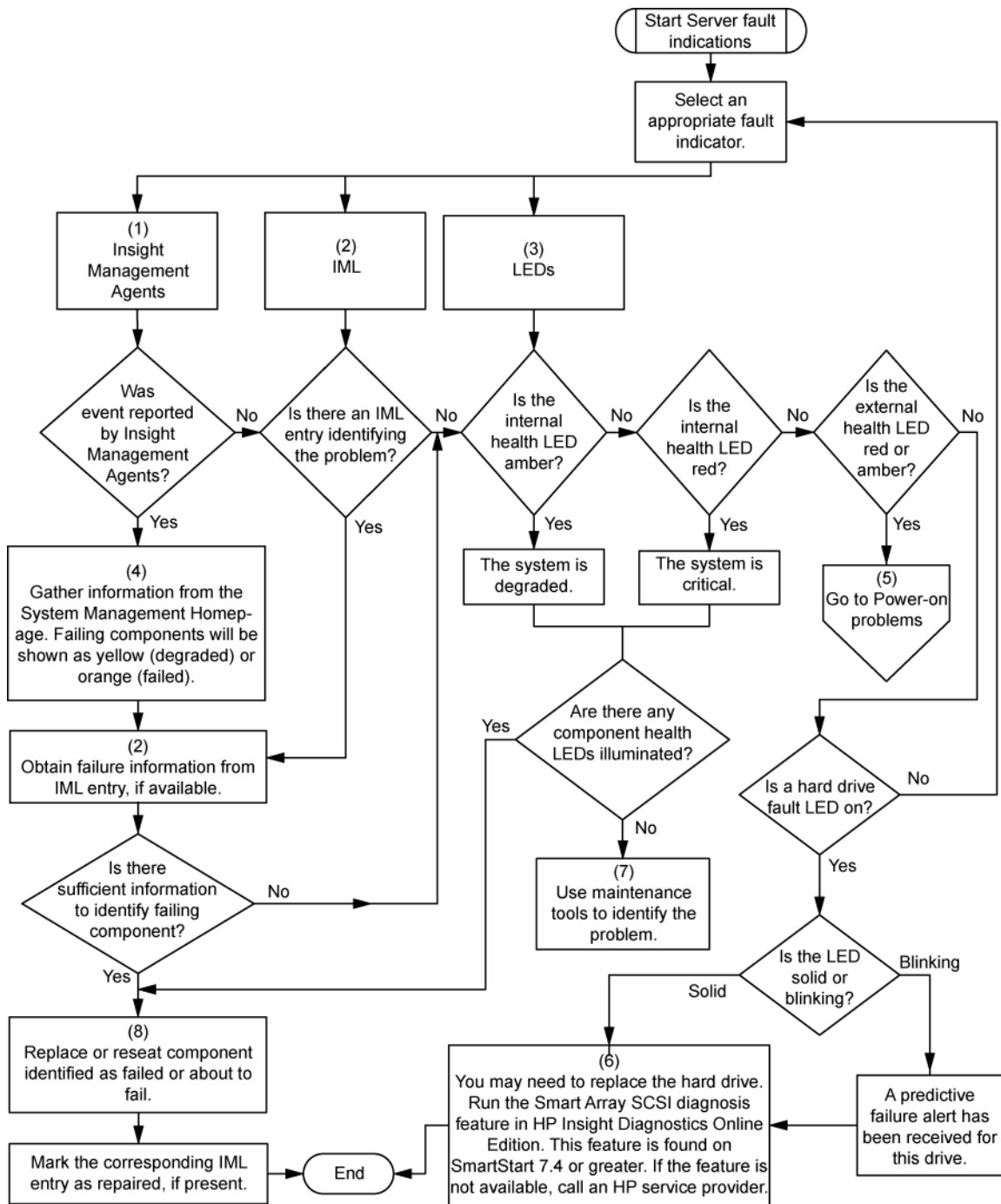

POST error messages and beep codes

Introduction to POST error messages

The error messages and codes in this section include all new messages generated by this server. Some messages are informational and do not indicate an error. A server generates only the codes that are applicable to its configuration and options.

For a complete listing of error messages, refer to the "POST error messages" in the *HP ProLiant Servers Troubleshooting Guide* located on the Documentation CD or on the HP website (<http://www.hp.com/support>).



WARNING: To avoid potential problems, ALWAYS read the warnings and cautionary information in the server documentation before removing, replacing, reseating, or modifying system components

Power Supply Solution Not Fully Redundant

Audible beeps: None

Possible cause: The minimum power supply requirement is installed, but a redundant power supply is missing or failed.

Action: Do one of the following:

- Install a power supply.
- Replace failed power supplies to complete redundancy.

207-Invalid Memory Configuration - DIMMs must be installed in pairs or sequentially

Audible beeps: 1 long, 1 short

Possible cause: The system is configured with only one FBDIMM and the system does not support single FBDIMM mode, or multiple FBDIMMs are installed but were not installed in the proper order.

Action: Do one of the following:

- Install a valid FBDIMM pair if the system does not support single channel memory mode.
- Remove and install FBDIMMs in the proper order.

Battery replacement

If the server no longer automatically displays the correct date and time, you may need to replace the battery that provides power to the real-time clock. Under normal use, battery life is 5 to 10 years.



WARNING: The computer contains an internal lithium manganese dioxide, a vanadium pentoxide, or an alkaline battery pack. A risk of fire and burns exists if the battery pack is not properly handled. To reduce the risk of personal injury:

- Do not attempt to recharge the battery.
- Do not expose the battery to temperatures higher than 60°C (140°F).
- Do not disassemble, crush, puncture, short external contacts, or dispose of in fire or water.
- Replace only with the spare designated for this product.

To remove the component:

1. Power down the server (on page 17).
2. Do one of the following:
 - Open or remove the tower bezel, as needed ("[Open or remove the tower bezel](#)" on page 18).
 - Extend the server from the rack (on page 17).
3. Remove the access panel (on page 19).
4. Remove the battery.

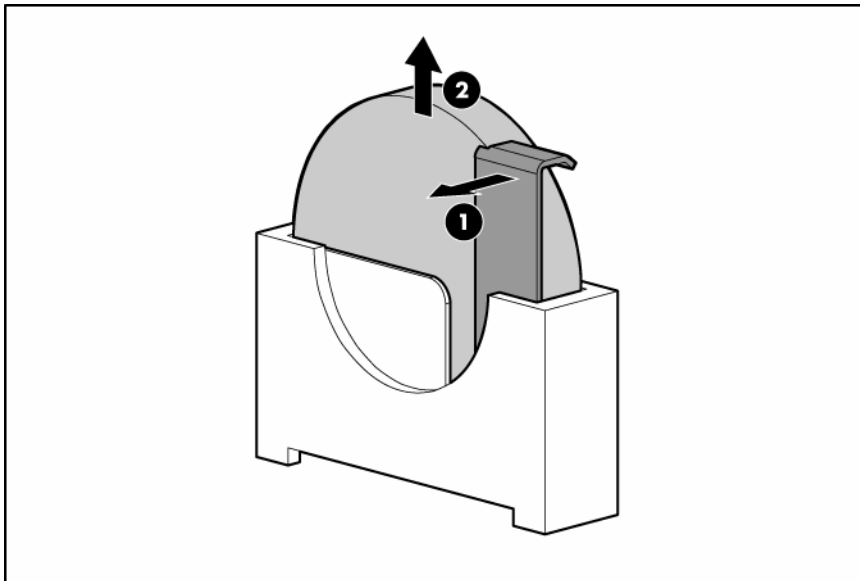

IMPORTANT: Replacing the system board battery resets the system ROM to its default configuration. After replacing the battery, reconfigure the system through RBSU.

To replace the component, reverse the removal procedure.

For more information about battery replacement or proper disposal, contact an authorized reseller or an authorized service provider.

Regulatory compliance notices

Regulatory compliance identification numbers

For the purpose of regulatory compliance certifications and identification, this product has been assigned a unique regulatory model number. The regulatory model number can be found on the product nameplate label, along with all required approval markings and information. When requesting compliance information for this product, always refer to this regulatory model number. The regulatory model number is not the marketing name or model number of the product.

Federal Communications Commission notice

Part 15 of the Federal Communications Commission (FCC) Rules and Regulations has established Radio Frequency (RF) emission limits to provide an interference-free radio frequency spectrum. Many electronic devices, including computers, generate RF energy incidental to their intended function and are, therefore, covered by these rules. These rules place computers and related peripheral devices into two classes, A and B, depending upon their intended installation. Class A devices are those that may reasonably be expected to be installed in a business or commercial environment. Class B devices are those that may reasonably be expected to be installed in a residential environment (for example, personal computers). The FCC requires devices in both classes to bear a label indicating the interference potential of the device as well as additional operating instructions for the user.

FCC rating label

The FCC rating label on the device shows the classification (A or B) of the equipment. Class B devices have an FCC logo or ID on the label. Class A devices do not have an FCC logo or ID on the label. After you determine the class of the device, refer to the corresponding statement.

Class A equipment

This equipment has been tested and found to comply with the limits for a Class A digital device, pursuant to Part 15 of the FCC Rules. These limits are designed to provide reasonable protection against harmful interference when the equipment is operated in a commercial environment. This equipment generates, uses, and can radiate radio frequency energy and, if not installed and used in accordance with the instructions, may cause harmful interference to radio communications. Operation of this equipment in a residential area is likely to cause harmful interference, in which case the user will be required to correct the interference at personal expense.

Class B equipment

This equipment has been tested and found to comply with the limits for a Class B digital device, pursuant to Part 15 of the FCC Rules. These limits are designed to provide reasonable protection against harmful interference in a residential installation. This equipment generates, uses, and can radiate radio frequency

energy and, if not installed and used in accordance with the instructions, may cause harmful interference to radio communications. However, there is no guarantee that interference will not occur in a particular installation. If this equipment does cause harmful interference to radio or television reception, which can be determined by turning the equipment off and on, the user is encouraged to try to correct the interference by one or more of the following measures:

- Reorient or relocate the receiving antenna.
- Increase the separation between the equipment and receiver.
- Connect the equipment into an outlet on a circuit that is different from that to which the receiver is connected.
- Consult the dealer or an experienced radio or television technician for help.

Declaration of conformity for products marked with the FCC logo, United States only

This device complies with Part 15 of the FCC Rules. Operation is subject to the following two conditions: (1) this device may not cause harmful interference, and (2) this device must accept any interference received, including interference that may cause undesired operation.

For questions regarding this product, contact us by mail or telephone:

- Hewlett-Packard Company
P. O. Box 692000, Mail Stop 530113
Houston, Texas 77269-2000
- 1-800-HP-INVENT (1-800-474-6836). (For continuous quality improvement, calls may be recorded or monitored.)

For questions regarding this FCC declaration, contact us by mail or telephone:

- Hewlett-Packard Company
P. O. Box 692000, Mail Stop 510101
Houston, Texas 77269-2000
- 1-281-514-3333

To identify this product, refer to the part, series, or model number found on the product.

Modifications

The FCC requires the user to be notified that any changes or modifications made to this device that are not expressly approved by Hewlett-Packard Company may void the user's authority to operate the equipment.

Cables

Connections to this device must be made with shielded cables with metallic RFI/EMI connector hoods in order to maintain compliance with FCC Rules and Regulations.

Canadian notice (Avis Canadien)

Class A equipment

This Class A digital apparatus meets all requirements of the Canadian Interference-Causing Equipment Regulations.

Cet appareil numérique de la classe A respecte toutes les exigences du Règlement sur le matériel brouilleur du Canada.

Class B equipment

This Class B digital apparatus meets all requirements of the Canadian Interference-Causing Equipment Regulations.

Cet appareil numérique de la classe B respecte toutes les exigences du Règlement sur le matériel brouilleur du Canada.

European Union regulatory notice

This product complies with the following EU Directives:

- Low Voltage Directive 2006/95/EC
- EMC Directive 2004/108/EC

Compliance with these directives implies conformity to applicable harmonized European standards (European Norms) which are listed on the EU Declaration of Conformity issued by Hewlett-Packard for this product or product family.

This compliance is indicated by the following conformity marking placed on the product:



This marking is valid for non-Telecom products and EU harmonized Telecom products (e.g. Bluetooth).



This marking is valid for EU non-harmonized Telecom products.

*Notified body number (used only if applicable—refer to the product label)

Hewlett-Packard GmbH, HQ-TRE, Herrenberger Strasse 140, 71034 Boeblingen, Germany



This symbol on the product or on its packaging indicates that this product must not be disposed of with your other household waste. Instead, it is your responsibility to dispose of your waste equipment by handing it over to a designated collection point for the recycling of waste electrical and electronic equipment. The separate collection and recycling of your waste equipment at the time of disposal will help to conserve natural resources and ensure that it is recycled in a manner that protects human health and the environment. For more information about where you can drop off your waste equipment for recycling, please contact your local city office, your household waste disposal service or the shop where you purchased the product.

Japanese notice

ご使用になっている装置にVCCIマークが付いていましたら、次の説明文をお読み下さい。

この装置は、情報処理装置等電波障害自主規制協議会（VCCI）の基準に基づくクラスB情報技術装置です。この装置は、家庭環境で使用することを目的としていますが、この装置がラジオやテレビジョン受信機に近接して使用されると、受信障害を引き起こすことがあります。

取扱説明書に従って正しい取り扱いをして下さい。

VCCIマークが付いていない場合には、次の点にご注意下さい。

この装置は、情報処理装置等電波障害自主規制協議会（VCCI）の基準に基づくクラスA情報技術装置です。この装置を家庭環境で使用すると電波妨害を引き起こすことがあります。この場合には使用者が適切な対策を講ずるよう要求されることがあります。

BSMI notice

警告使用者:

這是甲類的資訊產品，在居住的環境中使用時，可能會造成射頻干擾，在這種情況下，使用者會被要求採取某些適當的對策。

Korean notice

Class A equipment

A급 기기 (업무용 정보통신기기)

이 기기는 업무용으로 전자파적합등록을 한 기기이오니 판매자 또는 사용자는 이 점을 주의하시기 바라며, 만약 잘못판매 또는 구입하였을 때에는 가정용으로 교환하시기 바랍니다.

Class B equipment

B급 기기 (가정용 정보통신기기)

이 기기는 가정용으로 전자파적합등록을 한 기기로서 주거지역에서는 물론 모든지역에서 사용할 수 있습니다.

Laser compliance

This product may be provided with an optical storage device (that is, CD or DVD drive) and/or fiber optic transceiver. Each of these devices contains a laser that is classified as a Class 1 Laser Product in accordance with US FDA regulations and the IEC 60825-1. The product does not emit hazardous laser radiation.

Each laser product complies with 21 CFR 1040.10 and 1040.11 except for deviations pursuant to Laser Notice No. 50, dated May 27, 2001; and with IEC 60825-1:1993/A2:2001.



WARNING: Use of controls or adjustments or performance of procedures other than those specified herein or in the laser product's installation guide may result in hazardous radiation exposure. To reduce the risk of exposure to hazardous radiation:

- Do not try to open the module enclosure. There are no user-serviceable components inside.
- Do not operate controls, make adjustments, or perform procedures to the laser device other than those specified herein.
- Allow only HP Authorized Service technicians to repair the unit.

The Center for Devices and Radiological Health (CDRH) of the U.S. Food and Drug Administration implemented regulations for laser products on August 2, 1976. These regulations apply to laser products manufactured from August 1, 1976. Compliance is mandatory for products marketed in the United States.

Battery replacement notice



WARNING: The computer contains an internal lithium manganese dioxide, a vanadium pentoxide, or an alkaline battery pack. A risk of fire and burns exists if the battery pack is not properly handled. To reduce the risk of personal injury:

- Do not attempt to recharge the battery.
- Do not expose the battery to temperatures higher than 60°C (140°F).
- Do not disassemble, crush, puncture, short external contacts, or dispose of in fire or water.



Batteries, battery packs, and accumulators should not be disposed of together with the general household waste. To forward them to recycling or proper disposal, use the public collection system or return them to HP, an authorized HP Partner, or their agents.

For more information about battery replacement or proper disposal, contact an authorized reseller or an authorized service provider.

Taiwan battery recycling notice

The Taiwan EPA requires dry battery manufacturing or importing firms in accordance with Article 15 of the Waste Disposal Act to indicate the recovery marks on the batteries used in sales, giveaway or promotion. Contact a qualified Taiwanese recycler for proper battery disposal.



Power cord statement for Japan

製品には、同梱された電源コードをお使い下さい。
同梱された電源コードは、他の製品では使用出来ません。

Electrostatic discharge

Preventing electrostatic discharge

To prevent damaging the system, be aware of the precautions you need to follow when setting up the system or handling parts. A discharge of static electricity from a finger or other conductor may damage system boards or other static-sensitive devices. This type of damage may reduce the life expectancy of the device.

To prevent electrostatic damage:

- Avoid hand contact by transporting and storing products in static-safe containers.
- Keep electrostatic-sensitive parts in their containers until they arrive at static-free workstations.
- Place parts on a grounded surface before removing them from their containers.
- Avoid touching pins, leads, or circuitry.
- Always be properly grounded when touching a static-sensitive component or assembly.

Grounding methods to prevent electrostatic discharge

Several methods are used for grounding. Use one or more of the following methods when handling or installing electrostatic-sensitive parts:

- Use a wrist strap connected by a ground cord to a grounded workstation or computer chassis. Wrist straps are flexible straps with a minimum of 1 megohm ± 10 percent resistance in the ground cords. To provide proper ground, wear the strap snug against the skin.
- Use heel straps, toe straps, or boot straps at standing workstations. Wear the straps on both feet when standing on conductive floors or dissipating floor mats.
- Use conductive field service tools.
- Use a portable field service kit with a folding static-dissipating work mat.

If you do not have any of the suggested equipment for proper grounding, have an authorized reseller install the part.

For more information on static electricity or assistance with product installation, contact an authorized reseller.

Server specifications

Environmental specifications

Specification	Value
Temperature range*	
Operating	10°C to 35°C (50°F to 95°F)
Shipping	-40°C to 70°C (-40°F to 158°F)
Maximum wet bulb temperature	28°C (82.4°F)
Relative humidity (noncondensing)**	
Operating	10% to 90%
Non-operating	5% to 95%

* All temperature ratings shown are for sea level. An altitude derating of 1°C per 300 m (1.8°F per 1,000 ft) to 3048 m (10,000 ft) is applicable. No direct sunlight allowed.

** Storage maximum humidity of 95% is based on a maximum temperature of 45°C (113°F). Altitude maximum for storage corresponds to a pressure minimum of 70 KPa.

Server specifications

Specification	Value
Dimension	
Height (without tower feet)	44.45 cm (17.50 in)
Height (with tower feet)	46.7 cm (18.375 in)
Depth (with tower bezel)	60 cm (23.6 in)
Width	22 cm (8.66 in)
Weight (no drives installed)	27.22 kg (60 lb)
Models with a redundant power supply	
Input requirement	
Rated input voltage	100 VAC to 240 VAC
Rated input frequency	47 Hz to 63 Hz
Rated input current	10 A (110 V) to 5 A (220 V)
Rated input power	893 W
BTUs per hour	3049
Power supply output	
Rated steady-state power	800 W (low line), 1000 W (high line)

Specification	Value
Maximum peak power	1000 W (low line), 1200 W (high line)

Technical support

Related documents

For related documentation, refer to the Documentation CD.

Before you contact HP

Be sure to have the following information available before you call HP:

- Technical support registration number (if applicable)
- Product serial number
- Product model name and number
- Product identification number
- Applicable error messages
- Add-on boards or hardware
- Third-party hardware or software
- Operating system type and revision level

HP contact information

For the name of the nearest HP authorized reseller:

- In the United States, see the HP US service locator webpage (http://www.hp.com/service_locator).
- In other locations, see the Contact HP worldwide (in English) webpage (<http://welcome.hp.com/country/us/en/wwcontact.html>).

For HP technical support:

- In the United States, for contact options see the Contact HP United States webpage (http://welcome.hp.com/country/us/en/contact_us.html). To contact HP by phone:
 - Call 1-800-HP-INVENT (1-800-474-6836). This service is available 24 hours a day, 7 days a week. For continuous quality improvement, calls may be recorded or monitored.
 - If you have purchased a Care Pack (service upgrade), call 1-800-633-3600. For more information about Care Packs, refer to the HP website (<http://www.hp.com>).
- In other locations, see the Contact HP worldwide (in English) webpage (<http://welcome.hp.com/country/us/en/wwcontact.html>).

Customer Self Repair

HP products are designed with many Customer Self Repair (CSR) parts to minimize repair time and allow for greater flexibility in performing defective parts replacement. If during the diagnosis period HP (or HP service providers or service partners) identifies that the repair can be accomplished by the use of a CSR part, HP will ship that part directly to you for replacement. There are two categories of CSR parts:

- **Mandatory**—Parts for which customer self repair is mandatory. If you request HP to replace these parts, you will be charged for the travel and labor costs of this service.
- **Optional**—Parts for which customer self repair is optional. These parts are also designed for customer self repair. If, however, you require that HP replace them for you, there may or may not be additional charges, depending on the type of warranty service designated for your product.

NOTE: Some HP parts are not designed for customer self repair. In order to satisfy the customer warranty, HP requires that an authorized service provider replace the part. These parts are identified as "No" in the Illustrated Parts Catalog.

Based on availability and where geography permits, CSR parts will be shipped for next business day delivery. Same day or four-hour delivery may be offered at an additional charge where geography permits. If assistance is required, you can call the HP Technical Support Center and a technician will help you over the telephone. HP specifies in the materials shipped with a replacement CSR part whether a defective part must be returned to HP. In cases where it is required to return the defective part to HP, you must ship the defective part back to HP within a defined period of time, normally five (5) business days. The defective part must be returned with the associated documentation in the provided shipping material. Failure to return the defective part may result in HP billing you for the replacement. With a customer self repair, HP will pay all shipping and part return costs and determine the courier/carrier to be used.

For more information about HP's Customer Self Repair program, contact your local service provider. For the North American program, refer to the HP website (<http://www.hp.com/go/selfrepair>).

Réparation par le client (CSR)

Les produits HP comportent de nombreuses pièces CSR (Customer Self Repair = réparation par le client) afin de minimiser les délais de réparation et faciliter le remplacement des pièces défectueuses. Si pendant la période de diagnostic, HP (ou ses partenaires ou mainteneurs agréés) détermine que la réparation peut être effectuée à l'aide d'une pièce CSR, HP vous l'envoie directement. Il existe deux catégories de pièces CSR:

- **Obligatoire** - Pièces pour lesquelles la réparation par le client est obligatoire. Si vous demandez à HP de remplacer ces pièces, les coûts de déplacement et main d'œuvre du service vous seront facturés.
- **Facultatif** - Pièces pour lesquelles la réparation par le client est facultative. Ces pièces sont également conçues pour permettre au client d'effectuer lui-même la réparation. Toutefois, si vous demandez à HP de remplacer ces pièces, l'intervention peut ou non vous être facturée, selon le type de garantie applicable à votre produit.

REMARQUE: Certaines pièces HP ne sont pas conçues pour permettre au client d'effectuer lui-même la réparation. Pour que la garantie puisse s'appliquer, HP exige que le remplacement de la pièce soit effectué par un Mainteneur Agréé. Ces pièces sont identifiées par la mention "Non" dans le Catalogue illustré.

Les pièces CSR sont livrées le jour ouvré suivant, dans la limite des stocks disponibles et selon votre situation géographique. Si votre situation géographique le permet et que vous demandez une livraison le jour même ou dans les 4 heures, celle-ci vous sera facturée. Pour bénéficier d'une assistance téléphonique, appelez le Centre d'assistance technique HP. Dans les documents envoyés avec la pièce de rechange CSR, HP précise s'il est nécessaire de lui retourner la pièce défectueuse. Si c'est le cas, vous devez le faire dans le délai indiqué, généralement cinq (5) jours ouvrés. La pièce et sa documentation doivent être retournées dans l'emballage fourni. Si vous ne retournez pas la pièce défectueuse, HP se réserve le droit de vous facturer les coûts de remplacement. Dans le cas d'une pièce CSR, HP supporte l'ensemble des frais d'expédition et de retour, et détermine la société de courses ou le transporteur à utiliser.

Pour plus d'informations sur le programme CSR de HP, contactez votre Mainteneur Agréé local. Pour plus d'informations sur ce programme en Amérique du Nord, consultez le site Web HP (<http://www.hp.com/go/selfrepair>).

Riparazione da parte del cliente

Per abbreviare i tempi di riparazione e garantire una maggiore flessibilità nella sostituzione di parti difettose, i prodotti HP sono realizzati con numerosi componenti che possono essere riparati direttamente dal cliente (CSR, Customer Self Repair). Se in fase di diagnostica HP (o un centro di servizi o di assistenza HP) identifica il guasto come riparabile mediante un ricambio CSR, HP lo spedisce direttamente al cliente per la sostituzione. Vi sono due categorie di parti CSR:

- **Obbligatorie** – Parti che devono essere necessariamente riparate dal cliente. Se il cliente ne affida la riparazione ad HP, deve sostenere le spese di spedizione e di manodopera per il servizio.
- **Opzionali** – Parti la cui riparazione da parte del cliente è facoltativa. Si tratta comunque di componenti progettati per questo scopo. Se tuttavia il cliente ne richiede la sostituzione ad HP, potrebbe dover sostenere spese aggiuntive a seconda del tipo di garanzia previsto per il prodotto.

NOTA: alcuni componenti HP non sono progettati per la riparazione da parte del cliente. Per rispettare la garanzia, HP richiede che queste parti siano sostituite da un centro di assistenza autorizzato. Tali parti sono identificate da un "No" nel Catalogo illustrato dei componenti.

In base alla disponibilità e alla località geografica, le parti CSR vengono spedite con consegna entro il giorno lavorativo seguente. La consegna nel giorno stesso o entro quattro ore è offerta con un supplemento di costo solo in alcune zone. In caso di necessità si può richiedere l'assistenza telefonica di un addetto del centro di supporto tecnico HP. Nel materiale fornito con una parte di ricambio CSR, HP specifica se il cliente deve restituire dei componenti. Qualora sia richiesta la resa ad HP del componente difettoso, lo si deve spedire ad HP entro un determinato periodo di tempo, generalmente cinque (5) giorni lavorativi. Il componente difettoso deve essere restituito con la documentazione associata nell'imballo di spedizione fornito. La mancata restituzione del componente può comportare la fatturazione del ricambio da parte di HP. Nel caso di riparazione da parte del cliente, HP sostiene tutte le spese di spedizione e resa e sceglie il corriere/vettore da utilizzare.

Per ulteriori informazioni sul programma CSR di HP contattare il centro di assistenza di zona. Per il programma in Nord America fare riferimento al sito Web **HP** (<http://www.hp.com/go/selfrepair>).

Customer Self Repair

HP Produkte enthalten viele CSR-Teile (Customer Self Repair), um Reparaturzeiten zu minimieren und höhere Flexibilität beim Austausch defekter Bauteile zu ermöglichen. Wenn HP (oder ein HP Servicepartner) bei der Diagnose feststellt, dass das Produkt mithilfe eines CSR-Teils repariert werden

kann, sendet Ihnen HP dieses Bauteil zum Austausch direkt zu. CSR-Teile werden in zwei Kategorien unterteilt:

- **Zwingend** – Teile, für die das Customer Self Repair-Verfahren zwingend vorgegeben ist. Wenn Sie den Austausch dieser Teile von HP vornehmen lassen, werden Ihnen die Anfahrt- und Arbeitskosten für diesen Service berechnet.
- **Optional** – Teile, für die das Customer Self Repair-Verfahren optional ist. Diese Teile sind auch für Customer Self Repair ausgelegt. Wenn Sie jedoch den Austausch dieser Teile von HP vornehmen lassen möchten, können bei diesem Service je nach den für Ihr Produkt vorgesehenen Garantiebedingungen zusätzliche Kosten anfallen.

HINWEIS: Einige Teile sind nicht für Customer Self Repair ausgelegt. Um den Garantieanspruch des Kunden zu erfüllen, muss das Teil von einem HP Servicepartner ersetzt werden. Im illustrierten Teilekatalog sind diese Teile mit „No“ bzw. „Nein“ gekennzeichnet.

CSR-Teile werden abhängig von der Verfügbarkeit und vom Lieferziel am folgenden Geschäftstag geliefert. Für bestimmte Standorte ist eine Lieferung am selben Tag oder innerhalb von vier Stunden gegen einen Aufpreis verfügbar. Wenn Sie Hilfe benötigen, können Sie das HP technische Support Center anrufen und sich von einem Mitarbeiter per Telefon helfen lassen. Den Materialien, die mit einem CSR-Ersatzteil geliefert werden, können Sie entnehmen, ob das defekte Teil an HP zurückgeschickt werden muss. Wenn es erforderlich ist, das defekte Teil an HP zurückzuschicken, müssen Sie dies innerhalb eines vorgegebenen Zeitraums tun, in der Regel innerhalb von fünf (5) Geschäftstagen. Das defekte Teil muss mit der zugehörigen Dokumentation in der Verpackung zurückgeschickt werden, die im Lieferumfang enthalten ist. Wenn Sie das defekte Teil nicht zurückschicken, kann HP Ihnen das Ersatzteil in Rechnung stellen. Im Falle von Customer Self Repair kommt HP für alle Kosten für die Lieferung und Rücksendung auf und bestimmt den Kurier-/Frachtdienst.

Weitere Informationen über das HP Customer Self Repair Programm erhalten Sie von Ihrem Servicepartner vor Ort. Informationen über das CSR-Programm in Nordamerika finden Sie auf der HP Website unter (<http://www.hp.com/go/selfrepair>).

Reparaciones del propio cliente

Los productos de HP incluyen muchos componentes que el propio usuario puede reemplazar (*Customer Self Repair*, CSR) para minimizar el tiempo de reparación y ofrecer una mayor flexibilidad a la hora de realizar sustituciones de componentes defectuosos. Si, durante la fase de diagnóstico, HP (o los proveedores o socios de servicio de HP) identifica que una reparación puede llevarse a cabo mediante el uso de un componente CSR, HP le enviará dicho componente directamente para que realice su sustitución. Los componentes CSR se clasifican en dos categorías:

- **Obligatorio:** componentes para los que la reparación por parte del usuario es obligatoria. Si solicita a HP que realice la sustitución de estos componentes, tendrá que hacerse cargo de los gastos de desplazamiento y de mano de obra de dicho servicio.
- **Opcional:** componentes para los que la reparación por parte del usuario es opcional. Estos componentes también están diseñados para que puedan ser reparados por el usuario. Sin embargo, si precisa que HP realice su sustitución, puede o no conllevar costes adicionales, dependiendo del tipo de servicio de garantía correspondiente al producto.

NOTA: Algunos componentes no están diseñados para que puedan ser reparados por el usuario. Para que el usuario haga valer su garantía, HP pone como condición que un proveedor de servicios autorizado realice la sustitución de estos componentes. Dichos componentes se identifican con la palabra "No" en el catálogo ilustrado de componentes.

Según la disponibilidad y la situación geográfica, los componentes CSR se enviarán para que lleguen a su destino al siguiente día laborable. Si la situación geográfica lo permite, se puede solicitar la entrega en el mismo día o en cuatro horas con un coste adicional. Si precisa asistencia técnica, puede llamar al Centro de asistencia técnica de HP y recibirá ayuda telefónica por parte de un técnico. Con el envío de materiales para la sustitución de componentes CSR, HP especificará si los componentes defectuosos deberán devolverse a HP. En aquellos casos en los que sea necesario devolver algún componente a HP, deberá hacerlo en el periodo de tiempo especificado, normalmente cinco días laborables. Los componentes defectuosos deberán devolverse con toda la documentación relacionada y con el embalaje de envío. Si no enviara el componente defectuoso requerido, HP podrá cobrarle por el de sustitución. En el caso de todas sustituciones que lleve a cabo el cliente, HP se hará cargo de todos los gastos de envío y devolución de componentes y escogerá la empresa de transporte que se utilice para dicho servicio.

Para obtener más información acerca del programa de Reparaciones del propio cliente de HP, póngase en contacto con su proveedor de servicios local. Si está interesado en el programa para Norteamérica, visite la página web de HP siguiente (<http://www.hp.com/go/selfrepair>).

Customer Self Repair

Veel onderdelen in HP producten zijn door de klant zelf te repareren, waardoor de reparatieduur tot een minimum beperkt kan blijven en de flexibiliteit in het vervangen van defecte onderdelen groter is. Deze onderdelen worden CSR-onderdelen (Customer Self Repair) genoemd. Als HP (of een HP Service Partner) bij de diagnose vaststelt dat de reparatie kan worden uitgevoerd met een CSR-onderdeel, verzendt HP dat onderdeel rechtstreeks naar u, zodat u het defecte onderdeel daarmee kunt vervangen. Er zijn twee categorieën CSR-onderdelen:

- **Verplicht:** Onderdelen waarvoor reparatie door de klant verplicht is. Als u HP verzoekt deze onderdelen voor u te vervangen, worden u voor deze service reiskosten en arbeidsloon in rekening gebracht.
- **Optioneel:** Onderdelen waarvoor reparatie door de klant optioneel is. Ook deze onderdelen zijn ontworpen voor reparatie door de klant. Als u echter HP verzoekt deze onderdelen voor u te vervangen, kunnen daarvoor extra kosten in rekening worden gebracht, afhankelijk van het type garanteservice voor het product.

OPMERKING: Sommige HP onderdelen zijn niet ontwikkeld voor reparatie door de klant. In verband met de garantievoorwaarden moet het onderdeel door een geautoriseerde Service Partner worden vervangen. Deze onderdelen worden in de geïllustreerde onderdelencatalogus aangemerkt met "Nee".

Afhankelijk van de leverbaarheid en de locatie worden CSR-onderdelen verzonden voor levering op de eerstvolgende werkdag. Levering op dezelfde dag of binnen vier uur kan tegen meerkosten worden aangeboden, indien dit mogelijk is gezien de locatie. Indien assistentie gewenst is, belt u een HP Service Partner om via de telefoon technische ondersteuning te ontvangen. HP vermeldt in de documentatie bij het vervangende CSR-onderdeel of het defecte onderdeel aan HP moet worden geretourneerd. Als het defecte onderdeel aan HP moet worden teruggezonden, moet u het defecte onderdeel binnen een bepaalde periode, gewoonlijk vijf (5) werkdagen, retourneren aan HP. Het defecte onderdeel moet met de bijbehorende documentatie worden geretourneerd in het meegeleverde verpakkingsmateriaal. Als u het defecte onderdeel niet terugzendt, kan HP u voor het vervangende onderdeel kosten in rekening brengen. Bij reparatie door de klant betaalt HP alle verzendkosten voor het vervangende en geretourneerde onderdeel en kiest HP zelf welke koerier/transportonderneming hiervoor wordt gebruikt.

Neem contact op met een Service Partner voor meer informatie over het Customer Self Repair programma van HP. Informatie over Service Partners vindt u op de **HP website** (<http://www.hp.nl/services/servicepartners>).

Reparo feito pelo cliente

Os produtos da HP são projetados com muitas peças para reparo feito pelo cliente (CSR) de modo a minimizar o tempo de reparo e permitir maior flexibilidade na substituição de peças com defeito. Se, durante o período de diagnóstico, a HP (ou fornecedores/parceiros de serviço da HP) concluir que o reparo pode ser efetuado pelo uso de uma peça CSR, a peça de reposição será enviada diretamente ao cliente. Existem duas categorias de peças CSR:

- **Obrigatória** – Peças cujo reparo feito pelo cliente é obrigatório. Se desejar que a HP substitua essas peças, serão cobradas as despesas de transporte e mão-de-obra do serviço.
- **Opcional** – Peças cujo reparo feito pelo cliente é opcional. Essas peças também são projetadas para o reparo feito pelo cliente. No entanto, se desejar que a HP as substitua, pode haver ou não a cobrança de taxa adicional, dependendo do tipo de serviço de garantia destinado ao produto.

OBSERVAÇÃO: Algumas peças da HP não são projetadas para o reparo feito pelo cliente. A fim de cumprir a garantia do cliente, a HP exige que um técnico autorizado substitua a peça. Essas peças estão identificadas com a marca "No" (Não), no catálogo de peças ilustrado.

Conforme a disponibilidade e o local geográfico, as peças CSR serão enviadas no primeiro dia útil após o pedido. Onde as condições geográficas permitirem, a entrega no mesmo dia ou em quatro horas pode ser feita mediante uma taxa adicional. Se precisar de auxílio, entre em contato com o Centro de suporte técnico da HP para que um técnico o ajude por telefone. A HP especifica nos materiais fornecidos com a peça CSR de reposição se a peça com defeito deve ser devolvida à HP. Nos casos em que isso for necessário, é preciso enviar a peça com defeito à HP dentro do período determinado, normalmente cinco (5) dias úteis. A peça com defeito deve ser enviada com a documentação correspondente no material de transporte fornecido. Caso não o faça, a HP poderá cobrar a reposição. Para as peças de reparo feito pelo cliente, a HP paga todas as despesas de transporte e de devolução da peça e determina a transportadora/serviço postal a ser utilizado.

Para obter mais informações sobre o programa de reparo feito pelo cliente da HP, entre em contato com o fornecedor de serviços local. Para o programa norte-americano, visite o site da HP (<http://www.hp.com/go/selfrepair>).

顧客自己修理保証サービス

修理時間を短縮し、故障部品の交換における高い柔軟性を確保するために、HP製品には多数の顧客自己修理（CSR）部品があります。診断の際に、CSR部品を使用すれば修理ができるとHP（HPまたはHP正規保守代理店）が判断した場合、HPはその部品を直接、お客様に発送し、お客様に交換していただきます。CSR部品には以下の2通りがあります。

- **必須** - 顧客自己修理が必須の部品。当該部品について、もしもお客様がHPに交換作業を依頼される場合には、その修理サービスに関する交通費および人件費がお客様に請求されます。
- **任意** - 顧客自己修理が任意である部品。この部品も顧客自己修理用です。当該部品について、もしもお客様がHPに交換作業を依頼される場合には、お買い上げの製品に適用される保証サービス内容の範囲内においては、別途費用を負担していただくことなく保証サービスを受けることができます。

注：HP製品の一部の部品は、顧客自己修理用ではありません。製品の保証を継続するためには、HPまたはHP正規保守代理店による交換作業が必須となります。部品カタログには、当該部品が顧客自己修理除外品である旨が記載されています。

部品供給が可能な場合、地域によっては、CSR部品を翌営業日に届くように発送します。また、地域によっては、追加費用を負担いただくことにより同日または4時間以内に届くように発送することも可能な場合があります。サポートが必要なときは、HPの修理受付窓口へ電話していただければ、技術者が電話でアドバイスします。交換用のCSR部品または同梱物には、故障部品をHPに返送する必要があるかどうかが表示されています。故障部品をHPに返送する必要がある場合は、指定期限内（通常は5営業日以内）に故障部品をHPに返送してください。故障部品を返送する場合は、届いた時の梱包箱に関連書類とともに入れてください。故障部品を返送しない場合、HPから部品費用が請求されます。顧客自己修理の際には、HPは送料および部品返送費を全額負担し、使用する宅配便会社や運送会社を指定します。

客户自行维修

HP 产品提供许多客户自行维修 (CSR) 部件，以尽可能缩短维修时间和在更换缺陷部件方面提供更大的灵活性。如果在诊断期间 HP（或 HP 服务提供商或服务合作伙伴）确定可以通过使用 CSR 部件完成维修，HP 将直接把该部件发送给您进行更换。有两类 CSR 部件：

- **强制性的** — 要求客户必须自行维修的部件。如果您请求 HP 更换这些部件，则必须为该服务支付差旅费和人工费用。
- **可选的** — 客户可以选择是否自行维修的部件。这些部件也是为客户自行维修设计的。不过，如果您要求 HP 为您更换这些部件，则根据为您的产品指定的保修服务类型，HP 可能收取或不再收取任何附加费用。

注：某些 HP 部件的设计并未考虑客户自行维修。为了满足客户保修的需要，HP 要求授权服务提供商更换相关部件。这些部件在部件图解目录中标记为“否”。

CSR 部件将在下一个工作日发运（取决于备货情况和允许的地理范围）。在允许的地理范围内，可在当天或四小时内发运，但要收取额外费用。如果需要帮助，您可以致电 HP 技术支持中心，将会有技术人员通过电话为您提供帮助。HP 会在随更换的 CSR 部件发运的材料中指明是否必须将有缺陷的部件返还给 HP。如果要求您将缺陷的部件返还给 HP，那么您必须在指定期限内（通常是五 (5) 个工作日）将缺陷部件发给 HP。有缺陷的部件必须随所提供的发运材料中的相关文件一起返还。如果未能送还缺陷的部件，HP 可能会要求您支付更换费用。客户自行维修时，HP 将承担所有相关运输和部件返回费用，并指定快递商/承运商。

有关 HP 客户自行维修计划的详细信息，请与您当地的服务提供商联系。有关北美地区的计划，请访问 HP 网站 (<http://www.hp.com/go/selfrepair>)。

客戶自行維修

HP 產品設計了許多「客戶自行維修」(CSR) 的零件以減少維修時間，並且使得更換瑕疵零件時能有更大的彈性。如果在診斷期間 HP (或 HP 服務供應商或維修夥伴) 辨認出此項維修工作可以藉由使用 CSR 零件來完成，則 HP 將直接寄送該零件給您作更換。CSR 零件分為兩種類別：

- **強制的** — 客戶自行維修所使用的零件是強制性的。如果您要求 HP 更換這些零件，HP 將會向您收取此服務所需的外出費用與勞動成本。
- **選購的** — 客戶自行維修所使用的零件是選購的。這些零件也設計用於客戶自行維修之用。不過，如果您要求 HP 為您更換，則可能需要也可能不需要負擔額外的費用，端視針對此產品指定的保固服務類型而定。

備註：某些 HP 零件沒有消費者可自行維修的設計。為符合客戶保固，HP 需要授權的服務供應商更換零件。這些零件在圖示的零件目錄中，被標示為「否」。

基於材料取得及環境允許的情況下，CSR 零件將於下一個工作日以快遞寄送。在環境的允許下當天或四小時內送達，則可能需要額外的費用。若您需要協助，可致電「HP 技術支援中心」，會有一位技術人員透過電話來協助您。不論損壞的零件是否必須退回，HP 皆會在與 CSR 替換零件一起運送的材料中註明。若要將損壞的零件退回 HP，您必須在指定的一段時間內（通常為五 (5) 個工作天），將損壞的零件寄回 HP。損壞的零件必須與寄送資料中隨附的相關技術文件一併退還。如果無法退還損壞的零件，HP 可能要向您收取替換費用。針對客戶自行維修情形，HP 將負責所有運費及零件退還費用並指定使用何家快遞/貨運公司。

如需 HP 的「客戶自行維修」方案詳細資訊，請連絡您當地的服務供應商。至於北美方案，請參閱 HP 網站 (<http://www.hp.com/go/selfrepair>)。

고객 셀프 수리

HP 제품은 수리 시간을 최소화하고 결함이 있는 부품 교체 시 더욱 융통성을 발휘할 수 있도록 하기 위해 고객 셀프 수리(CSR) 부품을 다량 사용하여 설계되었습니다. 진단 기간 동안 HP(또는 HP 서비스 공급업체 또는 서비스 협력업체)에서 CSR 부품을 사용하여 수리가 가능하다고 판단되면 HP는 해당 부품을 바로 사용자에게 보내어 사용자가 교체할 수 있도록 합니다. CSR 부품에는 두 가지 종류가 있습니다.

- **고객 셀프 수리가 의무 사항인 필수 부품.** 사용자가 HP에 이 부품의 교체를 요청할 경우 이 서비스에 대한 출장비 및 작업비가 청구됩니다.
- **고객 셀프 수리가 선택 사항인 부품.** 이 부품들도 고객 셀프 수리가 가능하도록 설계되었습니다. 하지만 사용자가 HP에 이 부품의 교체를 요청할 경우 사용자가 구입한 제품에 해당하는 보증 서비스 유형에 따라 추가 비용 없이 교체가 가능할 수 있습니다.

참고: 일부 HP 부품은 고객 셀프 수리가 불가능하도록 설계되었습니다. HP는 만족스러운 고객 보증을 위해 공인 서비스 제공업체를 통해 부품을 교체하도록 하고 있습니다. 이러한 부품들은 Illustrated Parts Catalog에 "No"라고 표시되어 있습니다.

CSR 부품은 재고 상태와 지리적 조건이 허용하는 경우 다음 영업일 납품이 가능하도록 배송이 이루어집니다. 지리적 조건이 허용하는 경우 추가 비용이 청구되는 조건으로 당일 또는 4시간 배송이 가능할 수도 있습니다. 도움이 필요하시면 HP 기술 지원 센터로 전화하십시오. 전문 기술자가 전화로 도움을 줄 것입니다. HP는 결함이 발생한 부품을 HP로 반환해야 하는지 여부를 CSR 교체 부품과 함께 배송된 자료에 지정합니다. 결함이 발생한 부품을 HP로 반환해야 하는 경우에는 지정된 기간 내(통상 영업일 기준 5일)에 HP로 반환해야 합니다. 이 때 결함이 발생한 부품은 제공된 포장 재료에 넣어 관련 설명서와 함께 반환해야 합니다. 결함이 발생한 부품을 반환하지 않는 경우 HP가 교체 부품에 대해 비용을 청구할 수 있습니다. 고객 셀프 수리의 경우, HP는 모든 운송 및 부품 반환 비용을 부담하며 이용할 운송업체 및 택배 서비스를 결정합니다.

HP 고객 셀프 수리 프로그램에 대한 자세한 내용은 가까운 서비스 제공업체에 문의하십시오. 북미 지역의 프로그램에 대해서는 HP 웹 사이트(<http://www.hp.com/go/selfrepair>)를 참조하십시오.

Acronyms and abbreviations

ABEND

abnormal end

ACU

Array Configuration Utility

ADU

Array Diagnostics Utility

ASR

Automatic Server Recovery

CS

cable select

DDR

double data rate

FBDIMM

fully buffered DIMM

IEC

International Electrotechnical Commission

iLO

Integrated Lights-Out

IML

Integrated Management Log

IRQ

interrupt request

LFF

large form-factor

NEMA

National Electrical Manufacturers Association

NFPA

National Fire Protection Association

NIC

network interface controller

NMI

non-maskable interrupt

ORCA

Option ROM Configuration for Arrays

PATA

parallel ATA

PCI Express

Peripheral Component Interconnect Express

PCI-X

peripheral component interconnect extended

PDU

power distribution unit

POST

Power-On Self Test

PPM

processor power module

PSP

ProLiant Support Pack

RBSU

ROM-Based Setup Utility

SAS

serial attached SCSI

SATA

serial ATA

SFF

small form-factor

SIM

Systems Insight Manager

TMRA

recommended ambient operating temperature

UID

unit identification

Index

A

access panel 19
accessing servers 18
additional information 77, 105
ADU (Array Diagnostic Utility) 74
airflow requirements 22
Altiris Deployment Solution 70
Altiris eXpress Deployment Server 70
ASR (Automatic Server Recovery) 71
authorized reseller 105
auto-configuration process 68
Automatic Server Recovery (ASR) 71
Autorun menu 67

B

batteries, replacing 100
battery 94, 100
battery-backed write cache (BBWC) 60
BIOS Serial Console 69
BIOS upgrade 71
boot options 69
BSMI notice 99
buttons 7, 8

C

cables 65, 66, 80, 97
cabling 65, 66
Canadian notice 98
Care Pack 21, 76
cautions 78
Change Control 76
components 7, 9, 11
configuration of system 27, 28, 67, 68
Configuration Replication Utility 68
configuration tools 67
connectors 7, 8, 9, 11, 13
contacting HP 105
creating a disk image 70
CSR (customer self repair) 106
customer self repair (CSR) 105, 106

D

Declaration of Conformity 97
deployment software 70
diagnosing problems 77, 80
diagnostic tools 67, 68, 70, 71, 74, 75
diagnostics utility 75
diskette image creation 70
drivers 75

E

electrical grounding requirements 23
electrostatic discharge 102
environmental requirements 21, 103
environmental specifications 103
Erase Utility 72
error messages 92
European Union notice 98
expansion boards 48, 49, 52, 62
expansion slot covers, removing 48
external health LED 7, 8

F

fans, installing 59
FBDIMM slot LEDs 13, 14
FBDIMM slot locations 11
FBDIMMs 11, 12, 13, 36, 37
features 7
Federal Communications Commission (FCC)
 notice 96, 97
flowcharts 81, 82, 84, 87, 88, 90
front bezel 18
front panel components 7
front panel LEDs 8
full-height media device 42

G

general diagnosis flowchart 82

H

half-height media device 42

- hard drive LEDs 15
- hard drives 15
- hard drives, determining status of 15
- hardware options 29
- hardware options installation 25, 29
- health driver 14, 71
- health LEDs 7, 8, 14, 15
- help resources 105
- HP Insight Diagnostics 75
- HP ProLiant Essentials Foundation Pack 28, 73
- HP ProLiant Essentials Rapid Deployment Pack 70
- HP Systems Insight Manager, overview 73
- HP technical support 105

I

- identification number 96
- iLO (Integrated Lights-Out) 71
- IML (Integrated Management Log) 75
- Important Safety Information document 77
- Insight Diagnostics 75
- installation services 21
- installation, server options 25, 29
- installing hardware 29
- installing operating system 28
- Integrated Lights-Out (iLO) 71
- Integrated Management Log (IML) 75
- internal health LED 7, 8, 14, 15

J

- Japanese notice 99

K

- Korean notices 99

L

- laser devices 100
- LED, health 7, 8, 14, 15
- LED, system power 8
- LED, UID 8, 10
- LEDs 7
- LEDs, front panel 8, 15
- LEDs, hard drive 15
- LEDs, NIC 7, 8, 10, 13, 14
- LEDs, rear panel 10
- LEDs, system board 13, 14
- LEDs, troubleshooting 77

M

- Management Agents 72
- management tools 71
- media devices 42, 65
- memory 36, 37
- memory, online spare 37

N

- NIC LEDs 7, 8, 10, 13, 14
- NMI jumper 12

O

- Online ROM Flash Component Utility 72
- operating systems 28, 76
- optimum environment 21
- Option ROM Configuration for Arrays (ORCA) 70
- options installation 25, 29
- ORCA (Option ROM Configuration for Arrays) 70
- OS boot problems flowchart 88

P

- PATA optical drive 42, 65
- PCI Express conversion card 52
- PCI-X expansion cage 52
- phone numbers 105
- POST problems flowchart 87
- power cord 78, 101
- power distribution unit (PDU) 23
- power LEDs, system 7, 8, 13
- Power On/Standby button 7, 8, 17, 27
- power requirements 23, 103
- power supplies 46, 93
- powering down 17
- powering up 17, 68
- power-on problems flowchart 84
- preparation procedures 80
- problem diagnosis 77
- processors 29
- ProLiant Support Pack (PSP) 76
- PSPs, overview 76

R

- rack installation 21, 24, 26
- rack stability 78
- rack warnings 24, 78
- RBSU (ROM-Based Setup Utility) 68
- RBSU configuration 68
- rear panel components 9

- redundant ROM 73
- registering the server 28
- regulatory compliance notices 96
- removable media cage 40
- required information 105
- ROM redundancy 73
- ROM, updating 72
- ROM-Based Setup Utility (RBSU) 68
- ROMPaq utility 71, 73

S

- safety considerations 24, 77
- SAS drives 15, 39
- SATA hard drive 15, 39
- SATA optical drive 42, 65
- scripted installation 67
- serial number 70
- serial port 51
- series number 96
- server fault indications flowchart 90
- server features and options 29
- site requirements 22
- SmartStart autorun menu 67
- SmartStart Scripting Toolkit 67
- SmartStart software 28
- SmartStart, overview 67
- space requirements 21
- specifications, environmental 103
- specifications, server 103
- start diagnosis flowchart 81
- static electricity 102
- support 105
- support packs 67
- supported operating systems 76
- symbols on equipment 78
- system battery 94
- system board 11, 13
- system board battery 100
- system board LEDs 13
- system maintenance switch 11, 12
- system power LED 8
- Systems Insight Manager 73

T

- Taiwan battery recycling notice 100
- tape drives 42
- technical support 105
- telephone numbers 105
- temperature requirements 22

- tower bezel, removing 18
- tower server, setting up 25
- tower to rack conversion 62
- troubleshooting 77

U

- UID LED 8, 10, 17
- updating the system ROM 73
- USB support 74
- utilities 67
- utilities, deployment 67, 70

V

- ventilation 21

W

- warnings 24, 78
- website, HP 105