

Installation and Assembly - Flat Panel Accessory for VCR/DVD Mount

Models: ACC931, ACC931-S

IMPORTANT! Read instruction sheet before you start installation and assembly.

Before you start make sure all parts listed are included with your product.

Parts Description	ACC931		ACC931-S
	Qty.	Part #	Part #
AA VCR/DVD bracket	1	201-1161	201-4161
BB M5 x 8 mm phillips screw	4	570-0005	570-0005
CC M5 x 20 mm phillips screw	4	510-1208	510-1208
DD spacer	4	540-1057	540-1057

AA

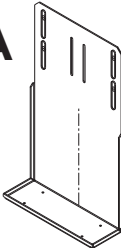

BB



CC

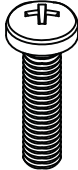

DD

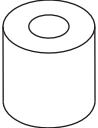

Some parts may appear slightly different than illustrated.

⚠ WARNING

- Do not overtighten! Overtightening may cause permanent damage to the screen. Torque to 26-35 in • lb (30-40 kg • cm).

1 Attach VCR/DVD bracket (**AA**) to back of adapter plate (sold separately) using the four screws included with adapter plate (sold separately) as shown below. Tighten screws using 4 mm security allen wrench included with adapter plate.

Note: Some parts may appear slightly different than illustrated.

2 Attach VCR/DVD mount (sold separately) to VCR/DVD bracket (**AA**) using four M5 x 8 mm phillips screws (**BB**) as shown below.

Note: If using model SP850-UNL mount, Attach VCR/DVD mount to VCR/DVD bracket (**AA**) using four M5 x 20 mm philips screws (**CC**) and four spacers (**DD**) as shown below.

