

SUPER

SC825 CHASSIS Series

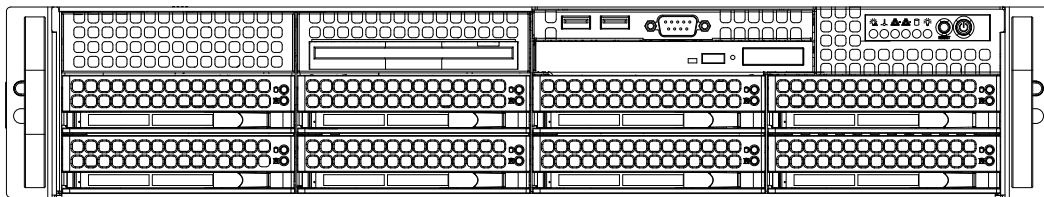

SC825TQ-R700V(B)

SC825TQ-R700RC2V(B)
(OEM)

SC825TQ-R700RCV(B)
(OEM)

SC825TQ-R700LPV(B)

SC825TQ-560LPV(B)

SC825S2-R700RC2V(B)
(OEM)

SC825S2-R700RCV(B)
(OEM)

SC825S2-R700LPV(B)

SC825S2-560LPV(B)

USER'S MANUAL

1.0

The information in this User's Manual has been carefully reviewed and is believed to be accurate. The vendor assumes no responsibility for any inaccuracies that may be contained in this document, makes no commitment to update or to keep current the information in this manual, or to notify any person or organization of the updates. **Please Note: For the most up-to-date version of this manual, please see our web site at www.supernmicro.com.**

SUPERMICRO COMPUTER reserves the right to make changes to the product described in this manual at any time and without notice. This product, including software, if any, and documentation may not, in whole or in part, be copied, photocopied, reproduced, translated or reduced to any medium or machine without prior written consent.

IN NO EVENT WILL SUPERMICRO COMPUTER BE LIABLE FOR DIRECT, INDIRECT, SPECIAL, INCIDENTAL, SPECULATIVE OR CONSEQUENTIAL DAMAGES ARISING FROM THE USE OR INABILITY TO USE THIS PRODUCT OR DOCUMENTATION, EVEN IF ADVISED OF THE POSSIBILITY OF SUCH DAMAGES. IN PARTICULAR, THE VENDOR SHALL NOT HAVE LIABILITY FOR ANY HARDWARE, SOFTWARE, OR DATA STORED OR USED WITH THE PRODUCT, INCLUDING THE COSTS OF REPAIRING, REPLACING, INTEGRATING, INSTALLING OR RECOVERING SUCH HARDWARE, SOFTWARE, OR DATA.

Any disputes arising between manufacturer and customer shall be governed by the laws of Santa Clara County in the State of California, USA. The State of California, County of Santa Clara shall be the exclusive venue for the resolution of any such disputes. Supermicro's total liability for all claims will not exceed the price paid for the hardware product.

Manual Revision 1.0

Release Date: January 19, 2007

Unless you request and receive written permission from SUPER MICRO COMPUTER, you may not copy any part of this document.

Information in this document is subject to change without notice. Other products and companies referred to herein are trademarks or registered trademarks of their respective companies or mark holders.

Copyright © 2007 by SUPER MICRO COMPUTER INC.

All rights reserved.

Printed in the United States of America

Preface

About This Manual

This manual is written for professional system integrators and PC technicians. It provides information for the installation and use of the SC825 2U chassis. Installation and maintenance should be performed by experienced technicians only.

Supermicro's SC825 2U chassis features a unique and highly-optimized design for dual-core Xeon platforms. The chassis is equipped with a 700W (redundant) or 560W (single) high efficiency power supply for superb power savings. High performance fans provide ample optimized cooling for FB-DIMM memory modules and 8 hot-swap drive bays.

This document lists compatible parts and configurations available when this document was published. Always refer to the our Web site for updates on supported parts and configurations.

Notes

Manual Organization

Chapter 1: Introduction

The first chapter provides a checklist of the main components included with this chassis and describes the main features of the SC825 chassis. This chapter also includes contact information.

Chapter 2: System Safety

This chapter lists warnings, precautions, and system safety. You should thoroughly familiarize yourself with this chapter for a general overview of safety precautions that should be followed before installing and servicing this chassis.

Chapter 3: Chassis Components

Refer here for details on this chassis model including the fans, bays, airflow shields, and other components.

Chapter 4: System Interface

Refer to this chapter for details on the system interface, which includes the functions and information provided by the control panel on the chassis as well as other LEDs located throughout the system.

Chapter 5: Chassis Setup and Installation

Refer to this chapter for detailed information on this chassis. You should follow the procedures given in this chapter when installing, removing, or reconfiguring your chassis.

Chapter 6: Rack Installation

Refer to this chapter for detailed information on chassis rack installation. You should follow the procedures given in this chapter when installing, removing or reconfiguring your chassis into a rack environment.

Compatible Backplanes

This section lists compatible cables, power supply specifications, and compatible backplanes. Not all compatible backplanes are listed. Refer to our Web site for the latest compatible backplane information.

Table of Contents

Preface

About This Manual	iii
Manual Organization	v

Chapter 1: Introduction

1-1 Overview.....	1-1
1-2 Shipping List.....	1-1
1-3 Chassis Features	1-2
CPU.....	1-2
Hard Drives	1-2
I/O Expansion slots	1-2
Peripheral Drives.....	1-2
Other Features	1-2
1-4 Contacting SuperMicro	1-3

Chapter 2: System Safety

2-1 Overview.....	2-1
2-2 Warnings and Precautions	2-1
2-3 Preparing for Setup	2-1
2-4 Electrical Safety Precautions	2-1
2-5 General Safety Precautions	2-3
2-6 System Safety	2-3

Chapter 3: Chassis Components

3-1 Overview.....	3-1
3-2 Components	3-1
Chassis.....	3-1
Backplane.....	3-1
Fans	3-1
Mounting Rails	3-2

Power Supply	3-2
Air Shroud	3-2
3-3 Where to get Replacement Components	3-2

Chapter 4: System Interface

4-1 Overview	4-1
4-2 Control Panel Buttons	4-2
4-3 Control Panel LEDs	4-2
4-4 Drive Carrier LEDs	4-4
SAS/SATA Drives	4-4
SCSI Drives	4-4

Chapter 5: Chassis Setup and Maintenance

5-1 Overview	5-1
5-2 Installation Steps	5-1
General Maintenance	5-1
5-3 Installation Step 1: Remove the Chassis Cover	5-2
To remove the chassis cover:	5-2
5-4 Installation Step 2: Install Hard Drives	5-3
To remove hard drive trays from the chassis	5-3
To install a hard drive to the hard drive tray	5-4
5-5 Installation Step 3: DVD and Floppy Drive Installation	5-6
To install or replace a DVD or Floppy Drive	5-6
5-6 Installation Step 4: Installing the Motherboard	5-7
I/O Shield:	5-7
To install the I/O shield:	5-7
Permanent and Optional Standoffs	5-8
To install the motherboard:	5-9
Add-on Card/Expansion Slot Setup	5-10
Add-on Card/Expansion Slot Setup in LP (Low Profile) chassis	5-10
To install add-on and expansion cards in SC825LP (low profile) chassis:	5-10
Add-on Card/Expansion Slot Setup in SC825RC (Riser Card) chassis	5-11
To install add-on/expansion cards in RC (Riser Card) chassis: .	5-11
Add-on Card/Expansion Slot Setup for SC825U (Universal Output)	

chassis.....	5-13
To install universal input/output card in SC825U chassis:.....	5-13
To install add-on cards to the SC825U chassis:.....	5-13
5-7 Installation Step 5: Installing the Air Shroud	5-14
To install the air shroud.....	5-14
To check the server's air flow	5-15
Installation Complete	5-15
5-8 System Fans	5-16
Replacing a system fan	5-16
5-9 Power Supply	5-18
Power Supply Failure	5-18
Replacing the Power Supply.....	5-19
Replacing the Power Distributor.....	5-20
Replacing the DVD-ROM, Front Panel, and Floppy Drive	5-21
To replace or install the DVD drive	5-22
To replace or install the Floppy drive.....	5-22
To replace or install the Front Port Panel	5-23

Chapter 6: Rack Installation

6-1 Overview.....	6-1
6-2 Unpacking the System	6-1
6-3 Preparing for Setup	6-1
Choosing a Setup Location	6-1
Rack Precautions	6-2
General Server Precautions.....	6-2
Rack Mounting Considerations	6-2
Ambient Operating Temperature	6-2
Reduced Airflow	6-3
Mechanical Loading	6-3
Circuit Overloading.....	6-3
Reliable Ground	6-3
6-4 Rack Mounting Instructions.....	6-4
Identifying the Sections of the Rack Rails	6-4
Locking Tabs	6-4
Installing the Inner Rail Extension	6-5

To install the inner rails	6-5
Installing the outer rails to the rack	6-6
Installing the chassis into a rack.....	6-7

Appendices

Appendix A: Compatible Cables

Appendix B: SC825 Power Supply Specifications

Appendix C: SAS 825TQ Backplane Manual

Appendix D: SAS 825S2 Backplane Manual

Chapter 1:

Introduction

1-1 Overview

Supermicro's SC825 2U chassis features a unique and highly-optimized design. The chassis is equipped with high efficiency power supply.

1-2 Shipping List

Please visit the following link for the latest shipping lists and part numbers for your particular chassis model <http://www.supermicro.com/products/chassis/1U/?chs=825>

SC825 Chassis				
Model	CPU	HDD	I/O Slots	Power Supply
SC825TQ-R700LP	DP Dual-core Xeon	8x SAS / SATA w/SES2	7x LP	700W Redundant
SC825TQ-560LP	DP Dual-core Xeon	8x SAS / SATA w/SES2	7x LP	560W
SC825S1-R700LP	DP Dual-core Xeon	8x Single-Channel (4 + 4) SCA w/SAF-TE	7x LP	700W Redundant
SC825S2-R700LPV	DP Dual-core Xeon	8x Dual-Channel (4 + 4) SCA w/SAF-TE	7x LP	700W Redundant
SC825S2-560LP	DP Dual-core Xeon	8x Dual-Channel (4 + 4) SCA w/SAF-TE	7x LP	560W
SC825TQ-R700RC2/R700RC (OEM)	DP Dual-core Xeon	8x SAS / SATA w/SES2	3 FF + 3 LP/ 3 FF	700W Redundant
SC825S2-R700RC2/R700RC (OEM)	DP Dual-core Xeon	8x Dual-Channel (4 + 4) SCA w/SAF-TE	3 FF + 3 LP/ 3 FF	700W Redundant

1-3 Chassis Features

The SC825 2U high performance chassis includes the following features:

CPU

The SC825 Chassis supports a Dual-core Xeon processor. Please refer to the motherboard specifications pages on our web site for updates on supported processors.

Hard Drives

The SC825 Chassis features 8 slots for U320 SCSI or SAS/SATA drives. These drives are hot swappable. Once setup correctly, these drives can be removed without powering down the server. In addition, these drives support SAF-TE (SCSI) and SES2 (SAS/SATA).

I/O Expansion slots

Each SC825 Chassis model includes seven low-profile I/O expansion slots.

Peripheral Drives

Each SC825 Chassis supports one slim DVD-ROM Drive (included) and one slim Floppy Drive (optional). These drives allow you to quickly install or save data.

Other Features

Other onboard features are included to promote system health. These include various three cooling fans, a convenient power switch, reset button, and 5 LED indicators.

1-4 Contacting SuperMicro

Headquarters

Address: SuperMicro Computer, Inc.
980 Rock Ave.
San Jose, CA 95131 U.S.A.

Tel: +1 (408) 503-8000

Fax: +1 (408) 503-8008

Email: marketing@supermicro.com (General Information)
support@supermicro.com (Technical Support)

Web Site: www.supermicro.com

Europe

Address: SuperMicro Computer B.V.
Het Sterrenbeeld 28, 5215 ML
's-Hertogenbosch, The Netherlands

Tel: +31 (0) 73-6400390

Fax: +31 (0) 73-6416525

Email: sales@supermicro.nl (General Information)
support@supermicro.nl (Technical Support)
rma@supermicro.nl (Customer Support)

Asia-Pacific

Address: SuperMicro, Taiwan
4F, No. 232-1, Liancheng Rd.
Chung-Ho 235, Taipei County
Taiwan, R.O.C.

Tel: +886-(2) 8226-3990

Fax: +886-(2) 8226-3991

Web Site: www.supermicro.com.tw

Technical Support:

Email: support@supermicro.com.tw

Tel: 886-2-8228-1366, ext.132 or 139

Notes

Chapter 2:

System Safety

2-1 Overview

This chapter provides a quick setup checklist to get your chassis up and running. Following the steps in order given should enable you to have your chassis setup and operational within a minimal amount of time. This quick set up assumes that you are an experienced technician, familiar with common concepts and terminology.

2-2 Warnings and Precautions

You should inspect the box the chassis was shipped in and note if it was damaged in any way. If the chassis itself shows damage, file a damage claim with carrier who delivered your system.

Decide on a suitable location for the rack unit that will hold that chassis. It should be situated in a clean, dust-free area that is well ventilated. Avoid areas where heat, electrical noise and electromagnetic fields are generated.

You will also need it placed near at least one grounded power outlet. When configured, the SC825 chassis includes one power supply. "R" models (i.e. SC825S-R700V Chassis) include a redundant power supply and require two grounded outlets.

2-3 Preparing for Setup

The SC825 Chassis includes a set of rail assemblies, including mounting brackets and mounting screws you will need to install the systems into the rack. Please read this manual in its entirety before you begin the installation procedure.

2-4 Electrical Safety Precautions

Basic electrical safety precautions should be followed to protect yourself from harm and the SC825 from damage:

- Be aware of the locations of the power on/off switch on the chassis as well as the room's emergency power-off switch, disconnection switch or electrical outlet. If an electrical accident occurs, you can then quickly remove power from the system.
- Do not work alone when working with high voltage components.
- Power should always be disconnected from the system when removing or installing main system components, such as the serverboard, memory modules and the DVD-ROM and floppy drives (not necessary for hot swappable drives). When disconnecting power, you should first power down the system with the operating system and then unplug the power cords from all the power supply modules in the system.
- When working around exposed electrical circuits, another person who is familiar with the power-off controls should be nearby to switch off the power, if necessary.
- Use only one hand when working with powered-on electrical equipment. This is to avoid making a complete circuit, which will cause electrical shock. Use extreme caution when using metal tools, which can easily damage any electrical components or circuit boards they come into contact with.
- Do not use mats designed to decrease electrostatic discharge as protection from electrical shock. Instead, use rubber mats that have been specifically designed as electrical insulators.
- The power supply power cord must include a grounding plug and must be plugged into grounded electrical outlets.
- Serverboard Battery: CAUTION - There is a danger of explosion if the onboard battery is installed upside down, which will reverse its polarities. This battery must be replaced only with the same or an equivalent type recommended by the manufacturer. Dispose of used batteries according to the manufacturer's instructions.
- DVD-ROM Laser: CAUTION - this server may have come equipped with a DVD-ROM drive. To prevent direct exposure to the laser beam and hazardous radiation exposure, do not open the enclosure or use the unit in any unconventional way.

2-5 General Safety Precautions

- Keep the area around the chassis clean and free of clutter.
- Place the chassis top cover and any system components that have been removed away from the system or on a table so that they won't accidentally be stepped on.
- While working on the system, do not wear loose clothing such as neckties and unbuttoned shirt sleeves, which can come into contact with electrical circuits or be pulled into a cooling fan.
- Remove any jewelry or metal objects from your body, which are excellent metal conductors that can create short circuits and harm you if they come into contact with printed circuit boards or areas where power is present.
- After accessing the inside of the system, close the system back up and secure it to the rack unit with the retention screws after ensuring that all connections have been made.

2-6 System Safety

Electrostatic discharge (ESD) is generated by two objects with different electrical charges coming into contact with each other. An electrical discharge is created to neutralize this difference, which can damage electronic components and printed circuit boards. The following measures are generally sufficient to neutralize this difference before contact is made to protect your equipment from ESD:

- Do not use mats designed to decrease electrostatic discharge as protection from electrical shock. Instead, use rubber mats that have been specifically designed as electrical insulators.
- Use a grounded wrist strap designed to prevent static discharge.
- Keep all components and printed circuit boards (PCBs) in their antistatic bags until ready for use.
- Touch a grounded metal object before removing any board from its anti-static bag.

- Do not let components or PCBs come into contact with your clothing, which may retain a charge even if you are wearing a wrist strap.
- Handle a board by its edges only; do not touch its components, peripheral chips, memory modules or contacts.
- When handling chips or modules, avoid touching their pins.
- Put the serverboard and peripherals back into their antistatic bags when not in use.
- For grounding purposes, make sure your computer chassis provides excellent conductivity between the power supply, the case, the mounting fasteners and the serverboard.

Chapter 3:

Chassis Components

3-1 Overview

This chapter describes the most common components included with your chassis. Some components listed may not be included or compatible with your particular chassis model. For more information, see the installation instructions detailed later in this manual.

3-2 Components

Chassis

Chassis include eight hard drive bays. Most chassis models come with a DVD-ROM. Hard drives must be purchased separately. For the latest shipping lists, visit our Web site at: <http://www.supermicro.com>.

This chassis accepts a 2U backplane, 3 fans and one (sometimes two) power supplies. SC825 models come in silver or black.

Backplane

Each SC825 chassis comes with a 2U backplane. Depending on our order, you backplane will accept SAS/SATA or SCSI. For more information regarding compatible backplanes, view the appendices found at the end of this manual. In addition, visit our Web site for the latest information: <http://www.supermicro.com>.

Fans

The SC825 chassis accepts three system fans. System fans for SC825 chassis are powered from the motherboard. These fans are 2U high and are powered by 3-pin connectors.

Mounting Rails

The SC825 can be placed in a rack for secure storage and use. To setup your rack, follow the step-by-step instructions included in this manual.

Power Supply

Each SC825 chassis model includes a high-efficiency power supply rated at 700 Watts (redundant) and 560W (single). In the unlikely event your power supply fails, replacement is simple and can be done without tools.

Air Shroud

Air shrouds are shields, usually plastic, that funnel air directly to where it is needed. Always use the air shroud included with your chassis.

3-3 Where to get Replacement Components

Though not frequently, you may need replacement parts for your system. To ensure the highest level of professional service and technical support, we strongly recommend purchasing exclusively from our Supermicro Authorized Distributors / System Integrators / Resellers. A list of Supermicro Authorized Distributors / System Integrators / Reseller can be found at: <http://www.supermicro.com>. Click the Where to Buy link.

Chapter 4: System Interface

4-1 Overview

There are several LEDs on the control panel as well as others on the drive carriers to keep you constantly informed of the overall status of the system as well as the activity and health of specific components. Most SC825 models are two buttons on the chassis a control panel: a reset button and an on/off switch. This chapter explains the meanings of all LED indicators and the appropriate response you may need to take.

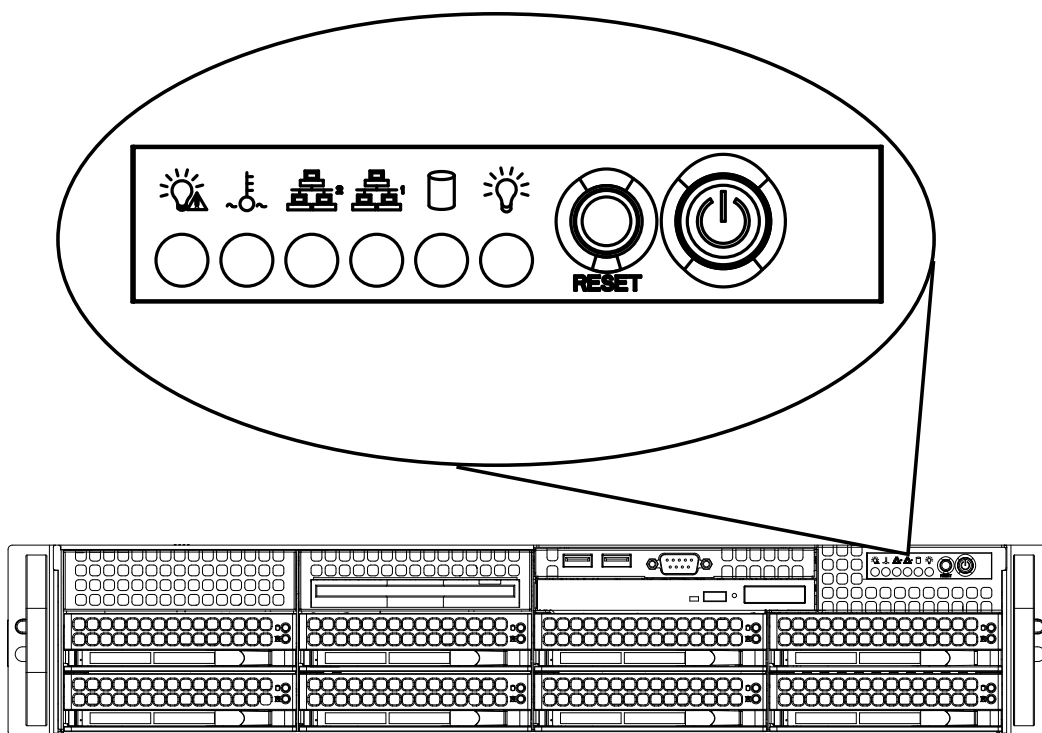

4-2 Control Panel Buttons

There are two push-buttons located on the front of the chassis. These are (in order from left to right) a reset button and a power on/off button.

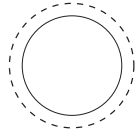

- **Reset:** The reset button is used to reboot the system.

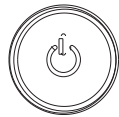

- **Power:** The main power switch is used to apply or remove power from the power supply to the server system. Turning off system power with this button removes the main power but keeps standby power supplied to the system. Therefore, you must unplug system before servicing.

4-3 Control Panel LEDs

The control panel located on the front of the SC825 chassis has five LEDs. These LEDs provide you with critical information related to different parts of the system. This section explains what each LED indicates when illuminated and any corrective action you may need to take.



- **Power Failure:** When this LED flashes, it indicates a power failure in the power supply.



- **Overheat/Fan Fail:** When this LED flashes it indicates a fan failure. When continuously on (not flashing) it indicates an overheat condition, which may be caused by cables obstructing the airflow in the system or the ambient room temperature being too warm. Check the routing of the cables and make sure all fans are present and operating normally. You should also check to make sure that the

chassis covers are installed. Finally, verify that the heatsinks are installed properly. This LED will remain flashing or on as long as the overheat condition exists.



- **NIC2:** Indicates network activity on GLAN2 when flashing.



- **NIC1:** Indicates network activity on GLAN1 when flashing.



- **HDD:** Indicates IDE channel activity. SAS/SATA drive, SCSI drive, and/or DVD-ROM drive activity when flashing.



- **Power:** Indicates power is being supplied to the system's power supply units. This LED should normally be illuminated when the system is operating.

4-4 Drive Carrier LEDs

Your chassis uses SAS/SATA or SCSI drives, but not both.

SAS/SATA Drives

Each SAS/SATA drive carrier has two LEDs.

- **Green:** Each Serial ATA drive carrier has a green LED. When illuminated, this green LED (on the front of the SATA drive carrier) indicates drive activity. A connection to the SATA backplane enables this LED to blink on and off when that particular drive is being accessed.
- **Red:** The red LED indicates a SAS/SATA drive failure. If one of the SAS/SATA drives fail, you should be notified by your system management software.

SCSI Drives

Each SCSI drive carrier has two LEDs.

- **Green:** When illuminated, the green LED on the front of the SCSI drive carrier indicates drive activity. A connection to the SCSI SCA backplane enables this LED to blink on and off when that particular drive is being accessed.
- **Red:** The red LED indicates a drive failure. If one of the SCSI drives fail, you should be notified by your system management software.

Chapter 5:

Chassis Setup and Maintenance

5-1 Overview

This chapter covers the steps required to install components and perform maintenance on the chassis. The only tool you will need to install components and perform maintenance is a Phillips screwdriver. Print this page to use as a reference while setting up your chassis.

5-2 Installation Steps

Step 1: Remove Chassis Cover

Step 2: Install Hard Drives

- A. Remove Hard Drive Trays from the Chassis
- B. Install a Hard Drive to the Hard Drive Tray

Step 3: DVD and Floppy Drive Installation

Step 4: Install the Motherboard (includes I/O Slot Setup)

Step 5: Install Air Shroud and Check Airflow

- A. Install Air Shroud.
- B. Check Airflow

General Maintenance

General Maintenance: Systems Fans

- A. Adding a New System Fan
- B. Replacing a System Fan

General Maintenance: Replace Power Supply



Review the warnings and precautions listed in the manual before setting up or servicing this chassis. These include information in Chapter 2: System Safety and the warning/precautions listed in the setup instructions.

5-3 Installation Step 1: Remove the Chassis Cover

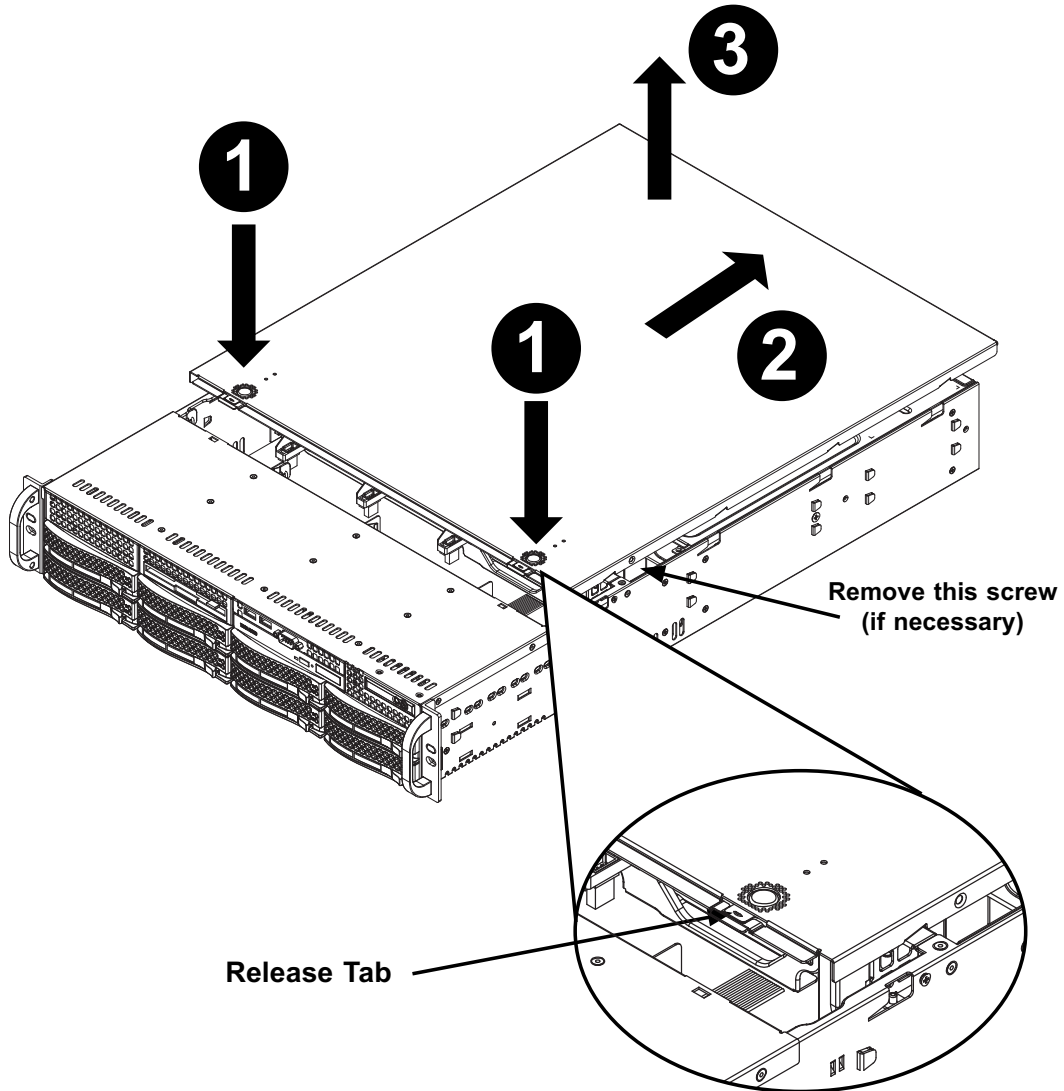

Figure 5-1: Removing the Chassis Cover

To remove the chassis cover:

1. Press the release tabs to remove the cover from the locked position. Press both tabs at the same time.
2. Once the top cover is released from the locked position, slide the cover toward the rear of the chassis.
3. Lift the cover off the chassis.



Warning: Except for short periods of time, do NOT operate the server without the cover in place. The chassis cover must be in place to allow proper airflow and prevent overheating.

5-4 Installation Step 2: Install Hard Drives

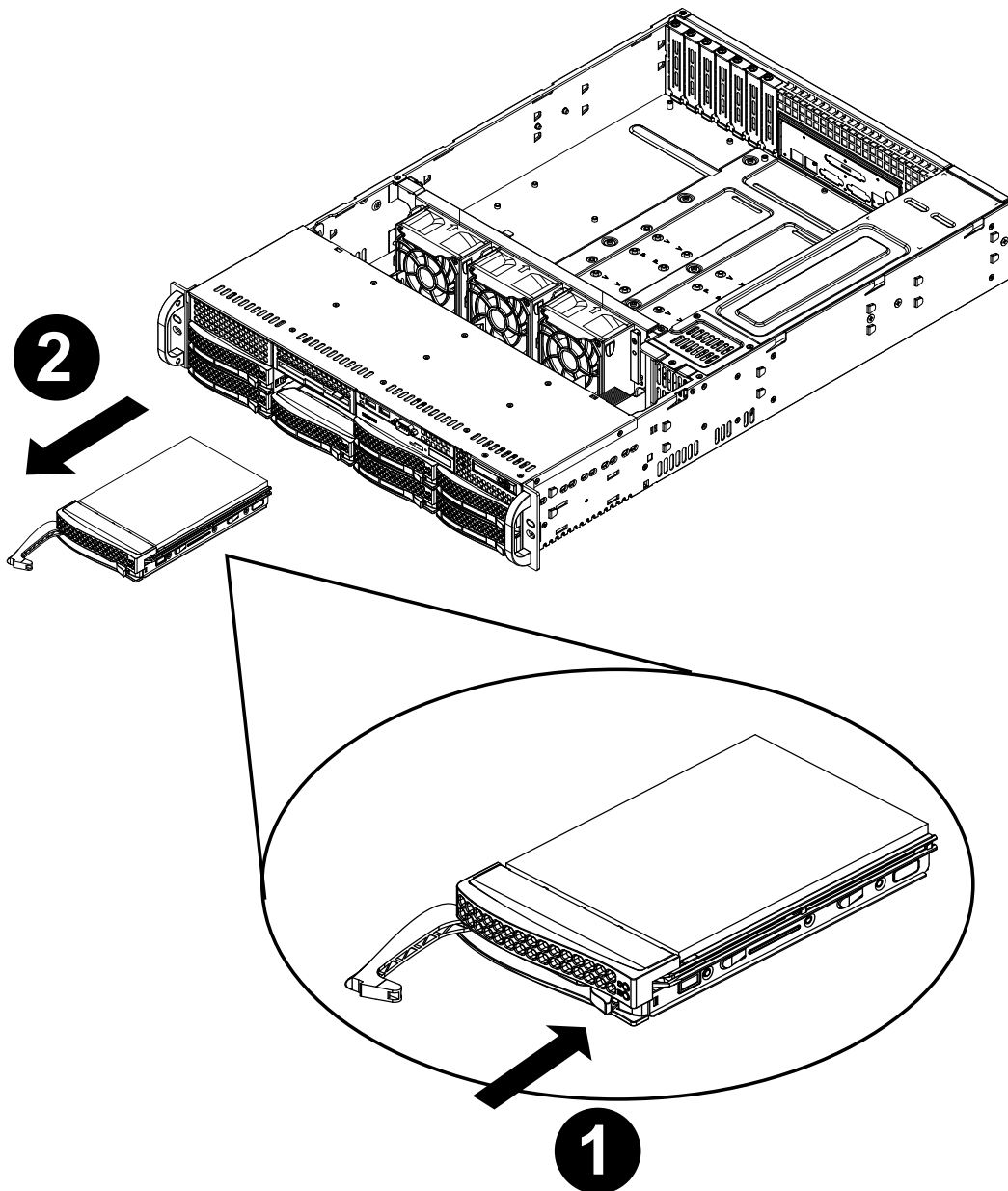

Figure 5-2: Removing Hard Drive

To remove hard drive trays from the chassis

1. Press the release button on the drive tray. This extends the drive bay handle.
2. Use the handle to pull the drive out of the chassis.

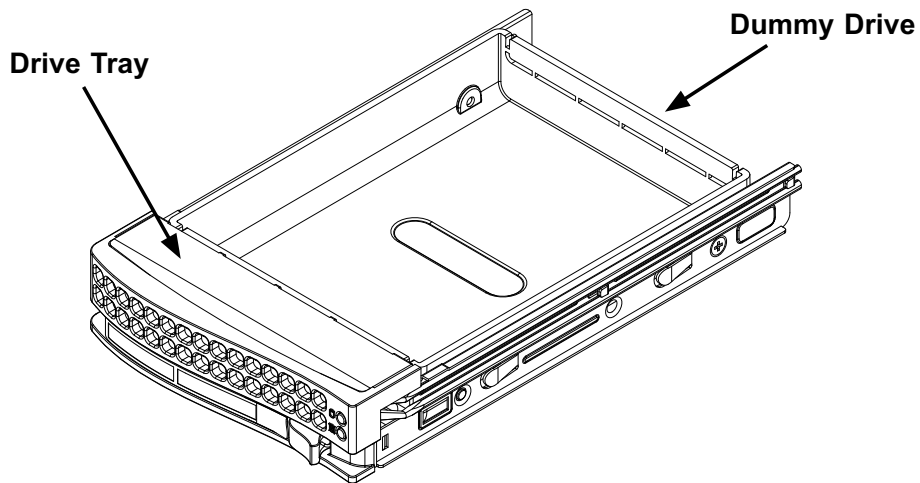

Figure 5-3: Chassis Drive Tray

The drives are mounted in drive carriers to simplify their installation and removal from the chassis. These carriers also help promote proper airflow for the drive bays.



Warning: Except for short periods of time (swapping hard drives), do not operate the server with the hard drives empty.

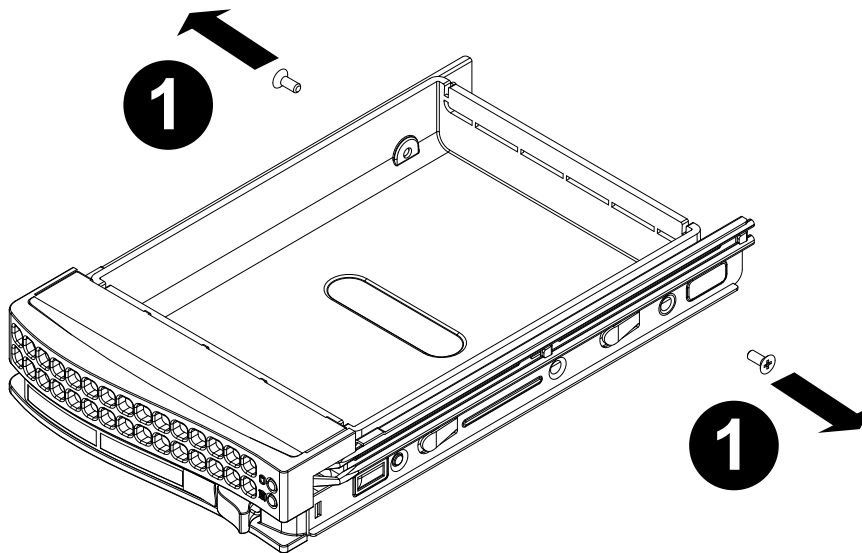

Figure 5-4: Removing Dummy Drive from Tray

To install a hard drive to the hard drive tray

1. Remove the screws (2) holding connecting the drive tray the carrier.
2. Remove the tray from the carrier.

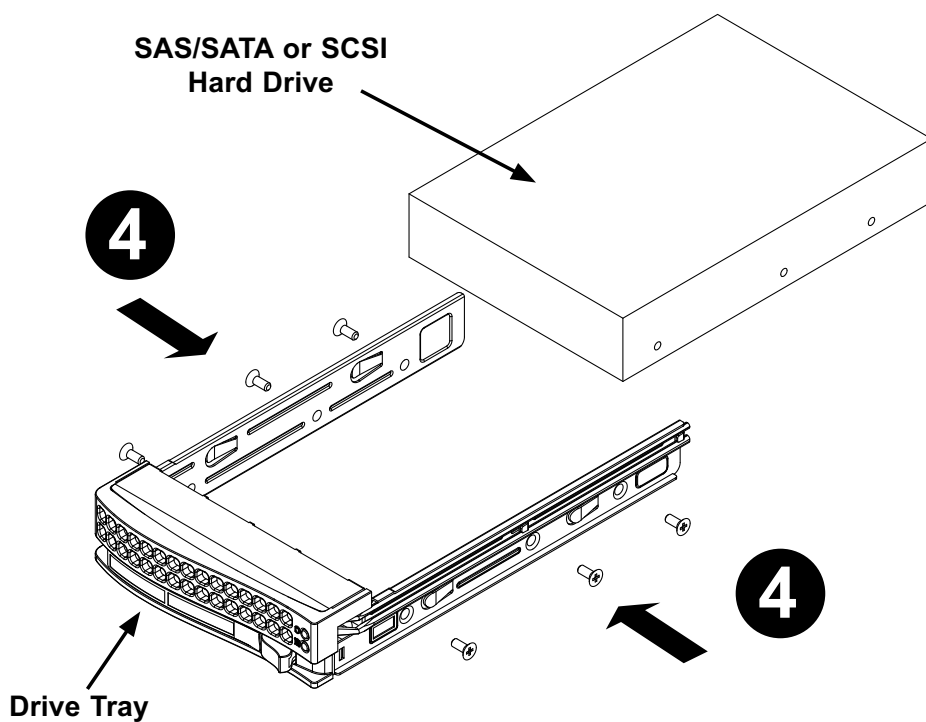

Figure 5-5: Removing Hard Drive

3. Install a new drive into the carrier with the printed circuit board side facing down so that the mounting holes align with those in the carrier.
4. Secure the hard drive by tightening all six (6) screws.
5. Replace the drive tray into the chassis. Make sure the close the drive tray handle.

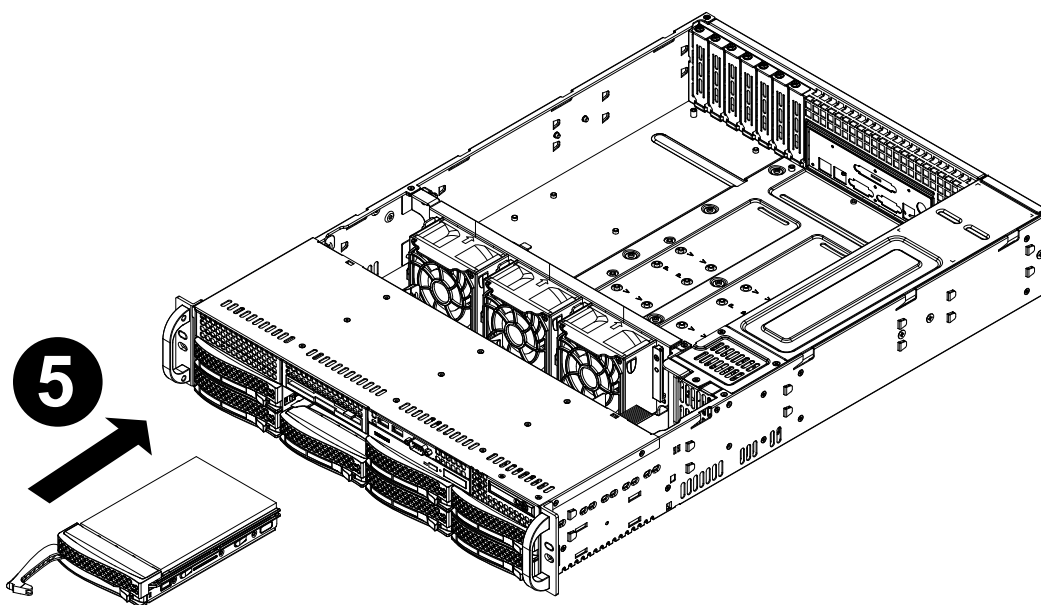

Figure 5-6: Removing Hard Drive

5-5 Installation Step 3: DVD and Floppy Drive Installation

Most SC825 chassis models include a DVD-ROM and space for an optional floppy drive. The DVD-ROM is usually pre-installed.

To install or replace a DVD or Floppy Drive

1. Power down the system and if necessary, remove the server from the rack.
2. Remove the chassis cover.
3. Unplug the drives power and data cables from the motherboard and/or backplane.
4. **If you are adding a new drive:** Remove the mini-bezel (grate) from the drive bay. The bezel can be removed by pulling out the hard drive beneath the DVD-ROM or Floppy drive bay, then pulling the mini-bezel forward.

If you are replacing a drive: Locate the locking tab at the rear (left hand side when viewed from the front) of the DVD-Rom or floppy drive. Push the tab toward the drive and push the drive unit out the front of the chassis.
5. Insert the new drive unit in the slot until the tab locks in place.
6. Reconnect the data and power cables.
7. Replace the chassis cover (replace the server in the rack, if necessary) and power up the system.

5-6 Installation Step 4: Installing the Motherboard

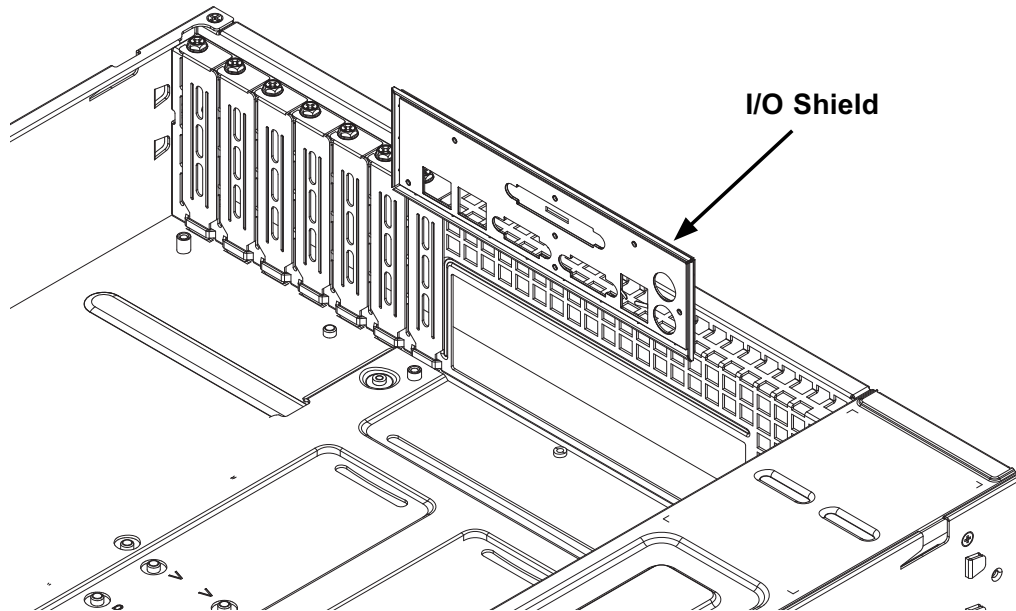

Figure 5-7: I/O Shield Placement

I/O Shield:

The I/O shield holds the motherboard ports in place. Install the I/O shield before you install the motherboard.

To install the I/O shield:

1. Review the documentation that came with your motherboard. Become familiar with component placement, requirements, and precautions.
2. Open the chassis cover.
3. With the illustrations facing the outside of the chassis, place the shield into the space provided.
4. Once installed, the motherboard will hold the I/O shield in place.

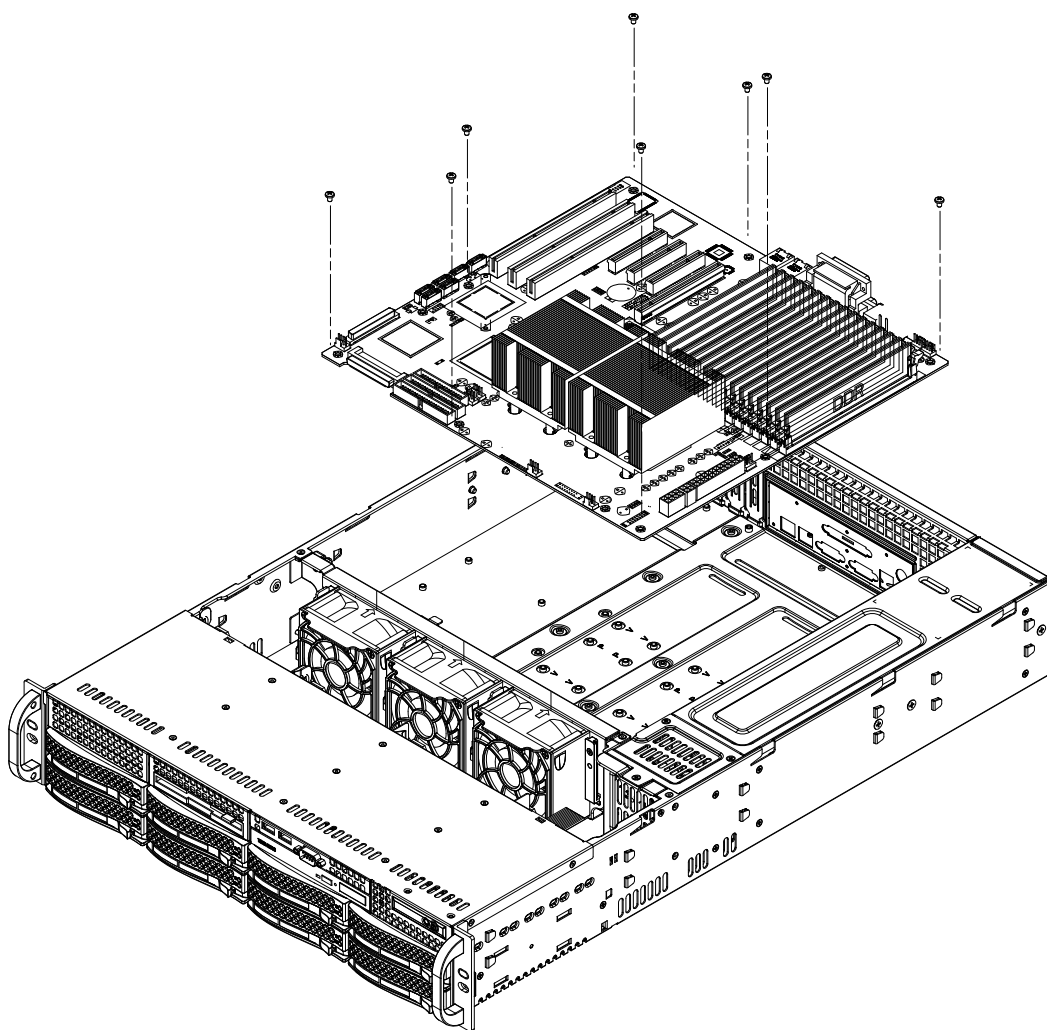

Figure 5-8: Chassis Standoffs

Permanent and Optional Standoffs

Standoffs prevent short circuits by securing space between the motherboard and the chassis surface. The SC825 chassis includes permanent standoffs in locations used by most motherboards. These standoffs accept the rounded Phillips head screws included in the SC825 accessories packaging.

Some motherboard require additional screws for heatsinks, general components and/or non-standard security. Optional standoffs are included to these motherboards. To use an optional standoff, you must place the hexagonal screw through the bottom the chassis and secure the screw with the hexagon nut (rounded side up).

To install the motherboard:

1. Review the documentation that came with your motherboard. Become familiar with component placement, requirements, precautions, and cable connections.
2. Open the chassis cover.
3. As required by your motherboard, install standoffs in any areas that do not have a permanent standoff. To do this:
 - A. Place a hexagonal standoff screw through the bottom the chassis.
 - B. Secure the screw with the hexagon nut (rounded side up).
4. Lay the motherboard on the chassis aligning the permanent and optional standoffs
5. Secure the motherboard to the chassis using the rounded, Phillips head screws.
6. Secure the CPU(s), heatsinks, and other components to the motherboard as described in the motherboard documentation.
7. Connect the cables between the motherboard, backplane, chassis, front panel, and power supply, as needed. Also, the fans may be temporarily removed to allow access to the backplane ports.

Add-on Card/Expansion Slot Setup

SC825 chassis include I/O slots for add-on cards and expansion cards. The number of cards you can use depends on your chassis model.

SC825 LP: Provides 7 low profile add-on card slots.

SC825 RC: Provides up to 3 full height/full length card slots. RC2 provides allows up to 3 full height/full length card slots and up to 3 low profile cards slots

SC825U: Provides 3 full height/full length and 3 low profile card slots through a user defined universal expansion card.

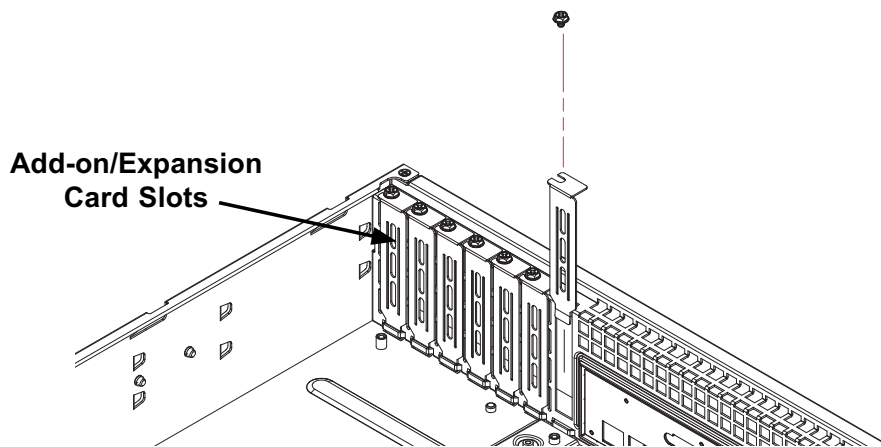

**Figure 5-9: SC825 LP model
Add-on Card/Expansion Slot Setup in LP (Low Profile)
chassis**

SC825 chassis include slots for add-on cards and expansion cards. The number of cards you can use depends on your chassis model and motherboard model.

To install add-on and expansion cards in SC825LP (low profile) chassis:

1. Disconnect the power supply, lay the chassis on a flat surface, and open the chassis cover.
2. Remove the screw holding the cover in place for each low profile add-on/expansion card slot you want to use. Keep this screw for later use.
3. Connect the add-on cards and/or expansion cards to the motherboard.
4. Secure each card to the chassis using the card's L bracket and the screw previously removed.

Add-on Card/Expansion Slot Setup in SC825RC (Riser Card) chassis

SC825 chassis RC models allow for up to 3 full height/full length card slots. RC2 allows up to 3 full height/full length card slots and up to 3 low profile cards slots.

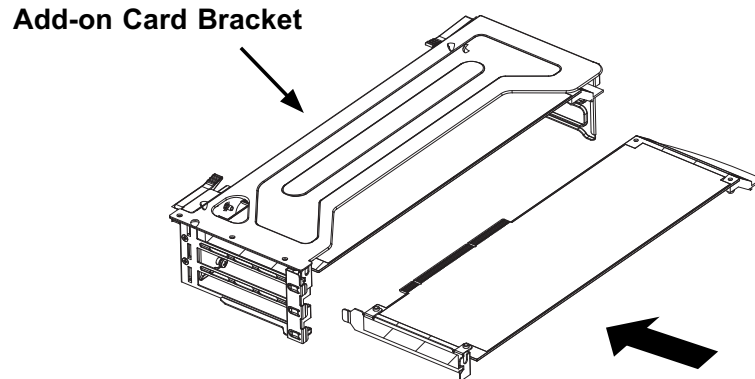

Figure 5-10: 3 Full Height/Full Length

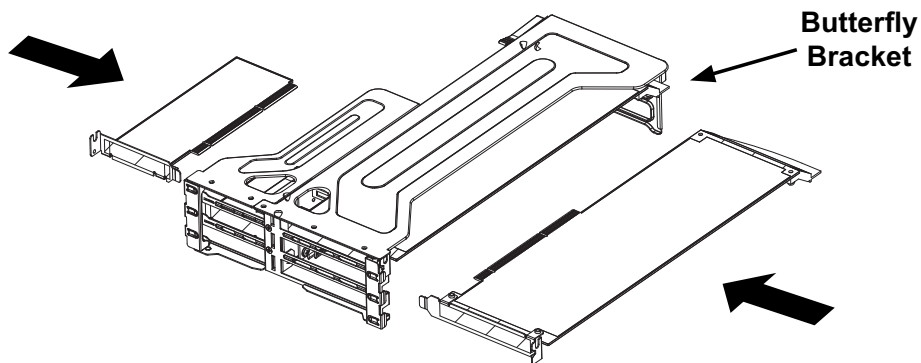

Figure 5-11: 3 Full Height/Full Length with 3 Low Profile Slot

To install add-on and expansion cards in RC (Riser Card) chassis:

1. Determine with type of riser card configuration you have ordered and the add-on/expansion cards you want to use.

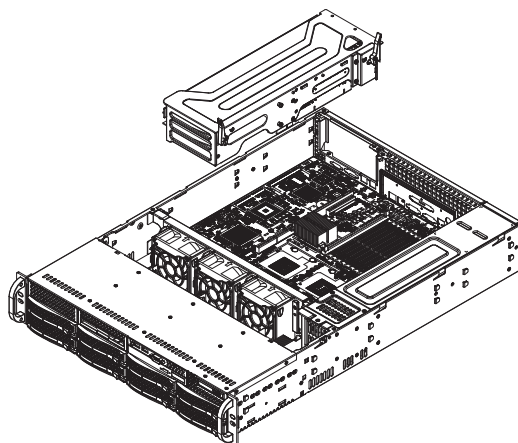

Figure 5-12: 3 Full Height/Full Length

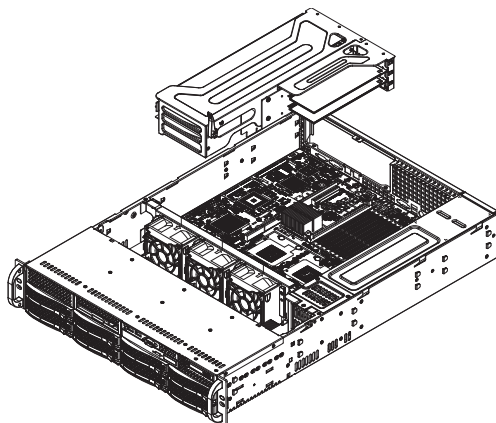

Figure 5-13: 3 Full Height/Full Length with 3 Low Profile Slot

2. Add your add-on/expansion cards to the riser card casing.
3. Slide the riser card into the chassis, aligning with both the motherboard slot and the back panel of the chassis.

If your riser card does not fit inside the chassis you may have the wrong riser card and motherboard combination.

Add-on Card/Expansion Slot Setup for SC825U (Universal Output) chassis

SC825U chassis accept a slightly smaller "L" shaped motherboard to allow for a universal expansion card. This universal output card allows the systems to accept SAS, SCSI, IB, Ethernet, and other types of connects.

SC825U chassis are setup similar to 825RC chassis with two differences:

- A. The SC825U chassis accepts three full length, full height add-on cards instead of four. The fourth slot is used for the U I/O card.
- B. The SC825U chassis includes a bracket that extends from the fan row to the back of the chassis. This bracket provides support for the riser card.

To install universal input/output card in SC825U chassis:

1. Disconnect the power supply, lay the chassis on a flat surface, and open the chassis cover.
2. Connect the universal input/output to the motherboard using the slots provided on the motherboard and the back panel.
3. Secure the card to the chassis using the four screws provided with the chassis packaging.

To install add-on cards to the SC825U chassis:

The SC825U chassis accepts 3 full height/full length slots and 3 low profile slots.

1. Disconnect the power supply, lay the chassis on a flat surface, and open the chassis cover.
2. If you are using a universal input/output card, make sure it is installed before continuing.
3. If you installing low profile add-on cards, remove the chassis air shroud.
4. Secure the card to the chassis using the four screws provided with the chassis packaging.

5-7 Installation Step 5: Installing the Air Shroud

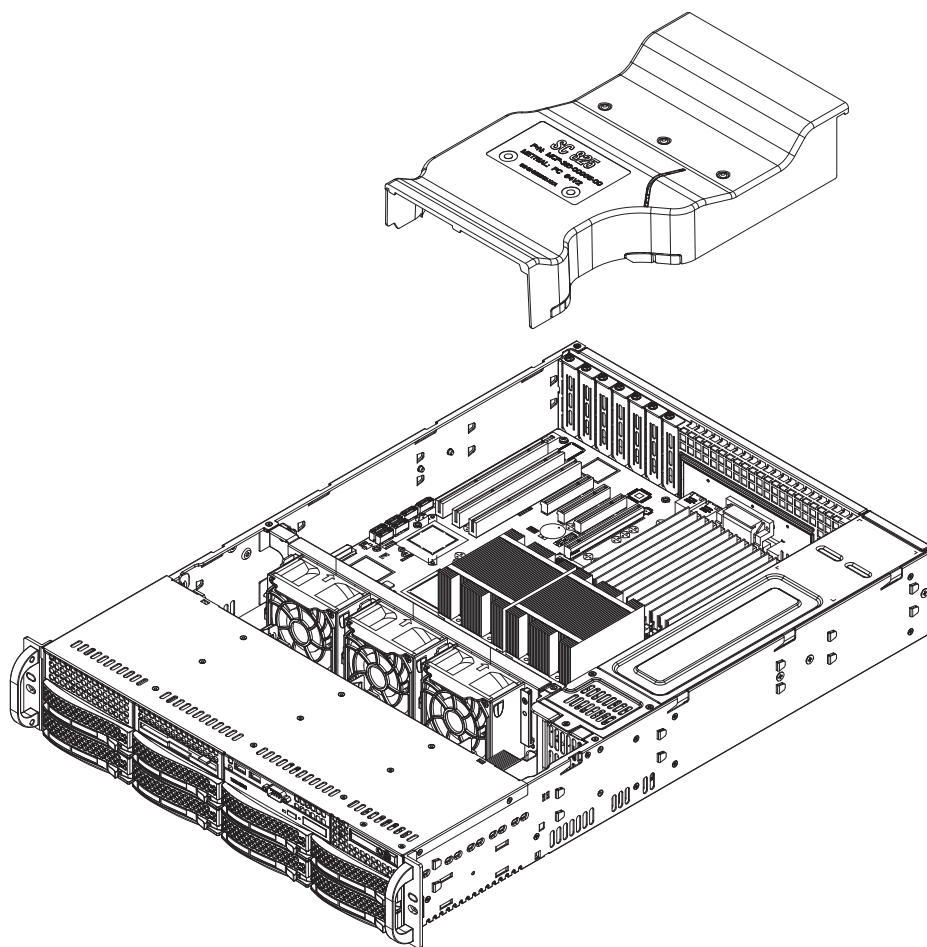

Figure 5-14: Air Shroud for SC825LP Chassis

Air shrouds concentrate airflow to maximize fan efficiency. The SC825 chassis air shroud does not require screws to set up.

To install the air shroud

1. Confirm that your air shroud matches your chassis model. Each shroud is labeled SC825LP, SC825RC, or SC825U,
2. Place air shroud in the chassis. The air shroud fits behind the two fans closest to the power supply.

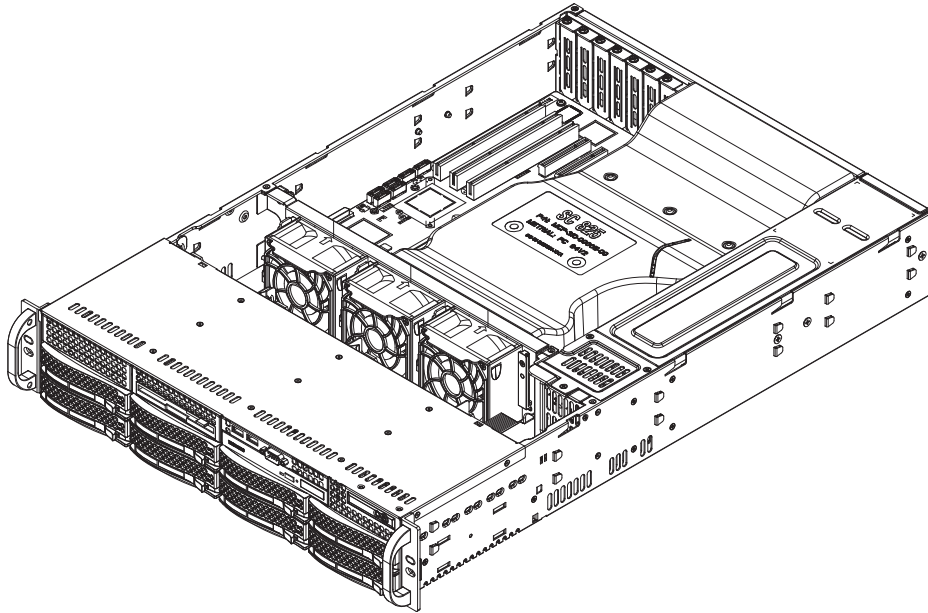

Figure 5-15: Air Shroud in place SC825LP Chassis

To check the server's air flow

1. Make sure there are no objects to obstruct airflow in and out of the server. In addition, if you are using a front bezel, make sure the bezel's filter is replaced periodically.
2. Do not operate the server without drives or drive trays in the drive bays. Use only recommended server parts.
3. Make sure no wires or foreign objects obstruct air flow through the chassis. Pull all excess cabling out of the airflow path or use shorter cables.

The control panel LEDs inform you of system status. See “Chapter 3: System Interface” for details on the LEDs and the control panel buttons.

Installation Complete

In most cases, the chassis power supply and fans are pre-installed. If you need to install fans continue to the Systems Fan section of this chapter. If the chassis will be installed into a rack, continue to the next chapter for rack installation instructions.

5-8 System Fans

Three heavy duty fans provide cooling for the chassis. These fans circulate air through the chassis as a means of lowering the chassis internal temperature.

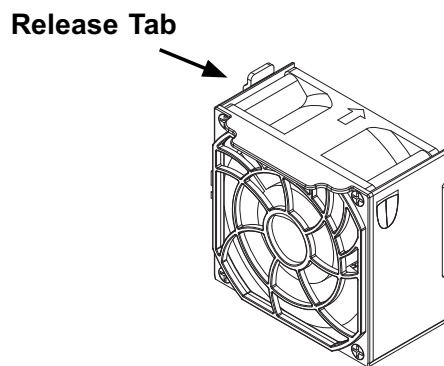

Figure 5-16: System Fan

Replacing a system fan

1. If necessary, open the chassis while the power is running to determine which fan has failed. (Never run the server for an extended period of time with the chassis open.)
2. Turn off the power to the system and unplug the system from the outlet.
3. Remove the failed fan's power cord from the serverboard.
4. Press the fan release tab to lift the failed fan from the chassis and pull it completely from the chassis.
5. Place the new fan into the vacant space in the housing while making sure the arrows on the top of the fan (indicating air direction) point in the same direction as the arrows on the other fans.
6. Power up the system and check that the fan is working properly before replacing the chassis cover.

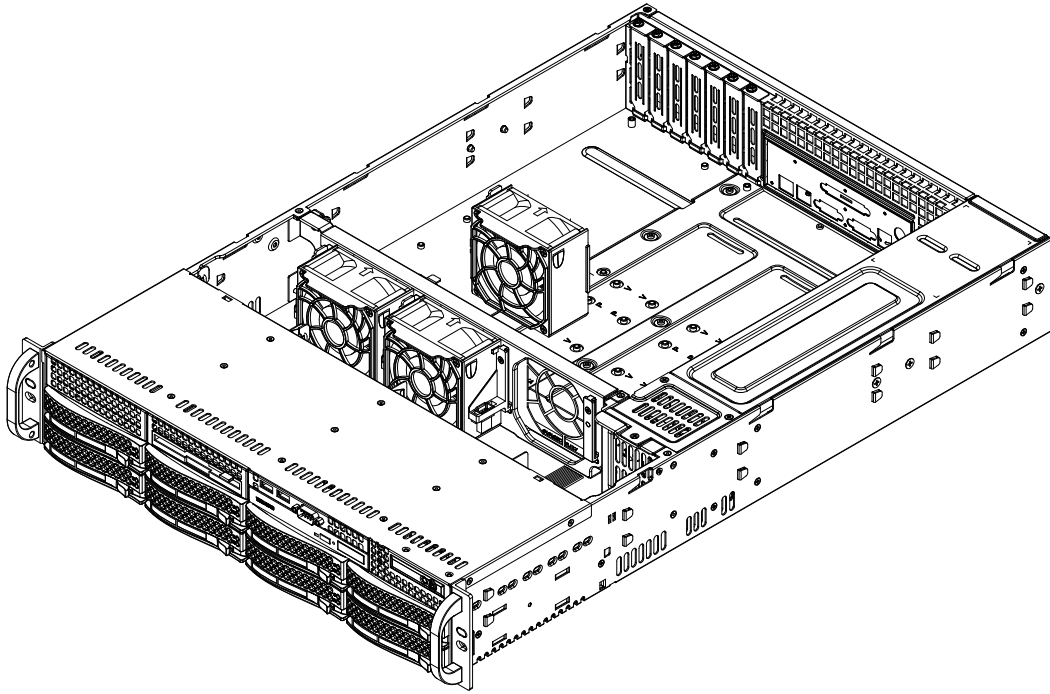

Figure 5-17: Placing the System Fan

5-9 Power Supply

Depending on your chassis model the SC825 Chassis has a 560 or 700 watt power supply. This power supply is auto-switching capable. This enables it to automatically sense and operate at a 100v to 240v input voltage. An amber light will be illuminated on the power supply when the power is off. An illuminated green light indicates that the power supply is operating.

Power Supply Failure

The SC825S2-560LP and SC825TQ-560LP chassis have one power supply. In the unlikely event that the power supply unit fails, the system will shut down and you will need to replace the power supply unit.

All other SC825 chassis models include a redundant power supply. Power supplies can be replaced without powering down the system.

Replacement units can be ordered directly from Supermicro (see contact information in the Preface).

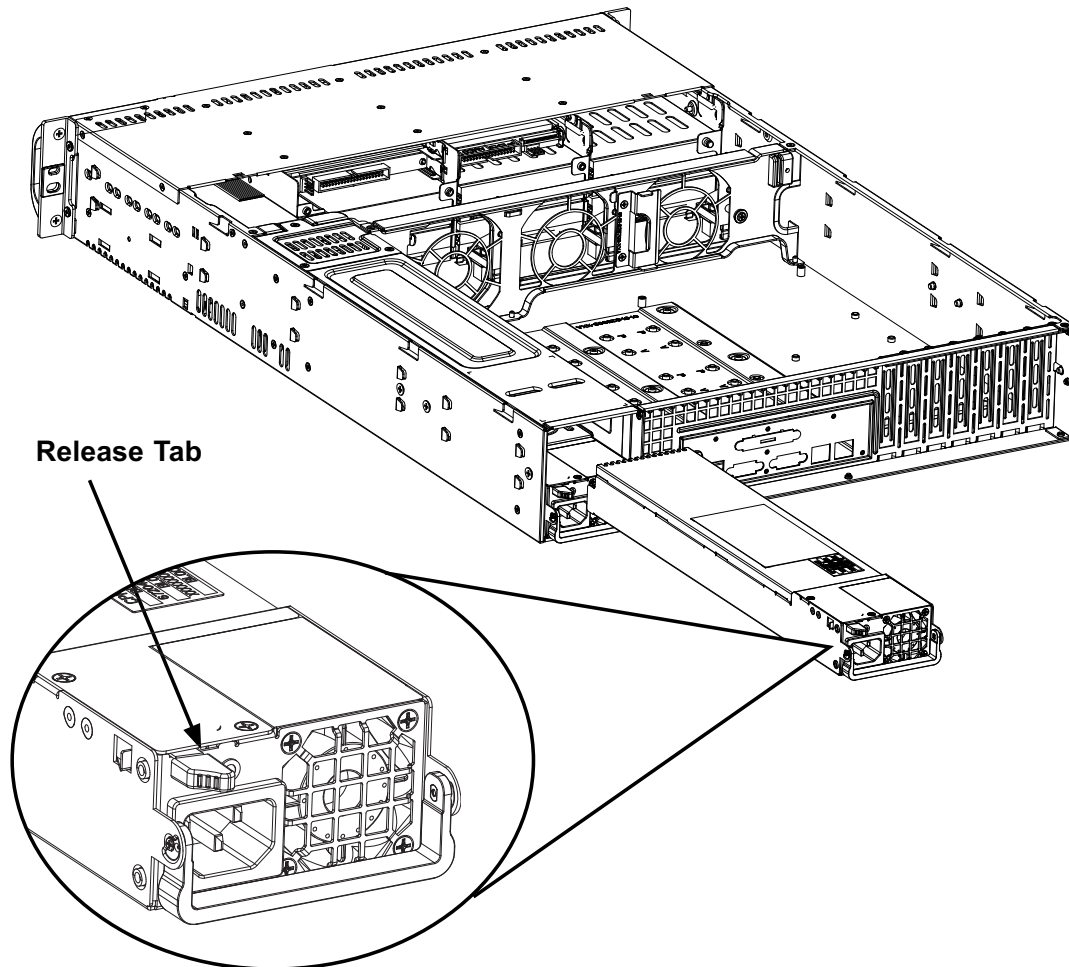

Figure 5-18: Removing the Power Supply

Replacing the Power Supply

1. If your chassis includes a redundant power supply (at least two power modules), you can leave the server running and remove only one power supply. If your server has only one power supply, you must power down the server and unplug the power cord.
2. Push the release tab (on the back of the power supply) as illustrated.
3. Pull the power supply out using the handle provided.
4. Replace the failed power module with the same model.
5. Push the new power supply module into the power bay until you hear a click.
6. Plug the AC power cord back into the module and power up the server.

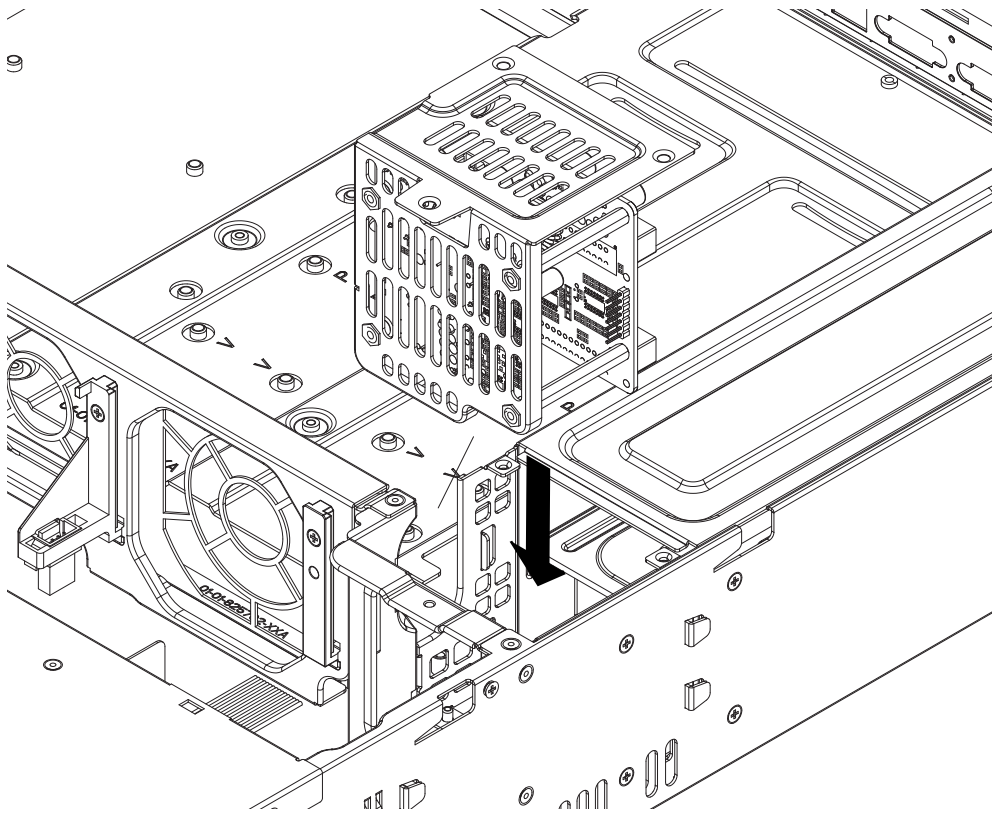

Figure 5-19: Replacing the Power Distributor

Replacing the Power Distributor

Redundant server chassis that are 2U or more high require a power distributor. The power distributor provides failover and power supply redundancy. In the unlikely event you must replace the power distributor, do following

1. Power down the server and remove the plug from the wall socket or power strip.
2. Remove all cable connections to the power supply from the motherboard, backplane, and other components. Also, remove both power supplies.
3. Locate the power distributor between the power supply and the fan row.
4. Remove the three screws securing the power supply.
5. Gently pull the power distributor from the chassis. Gently guide all the cables through the power distributor housing.
6. Slide the new power distributor module into the power distributor housing. Make that you slide the cables through the bottom of the housing.
7. Reconnect all the power cables, replace the power supply, and insert the plug into the wall.

Replacing the DVD-ROM, Front Panel, and Floppy Drive

SC836 chassis models include a slim DVD-ROM, slim Floppy Drive, and Front Port Panel. Use the instructions in this section in the unlikely event that you must replace any of these components.

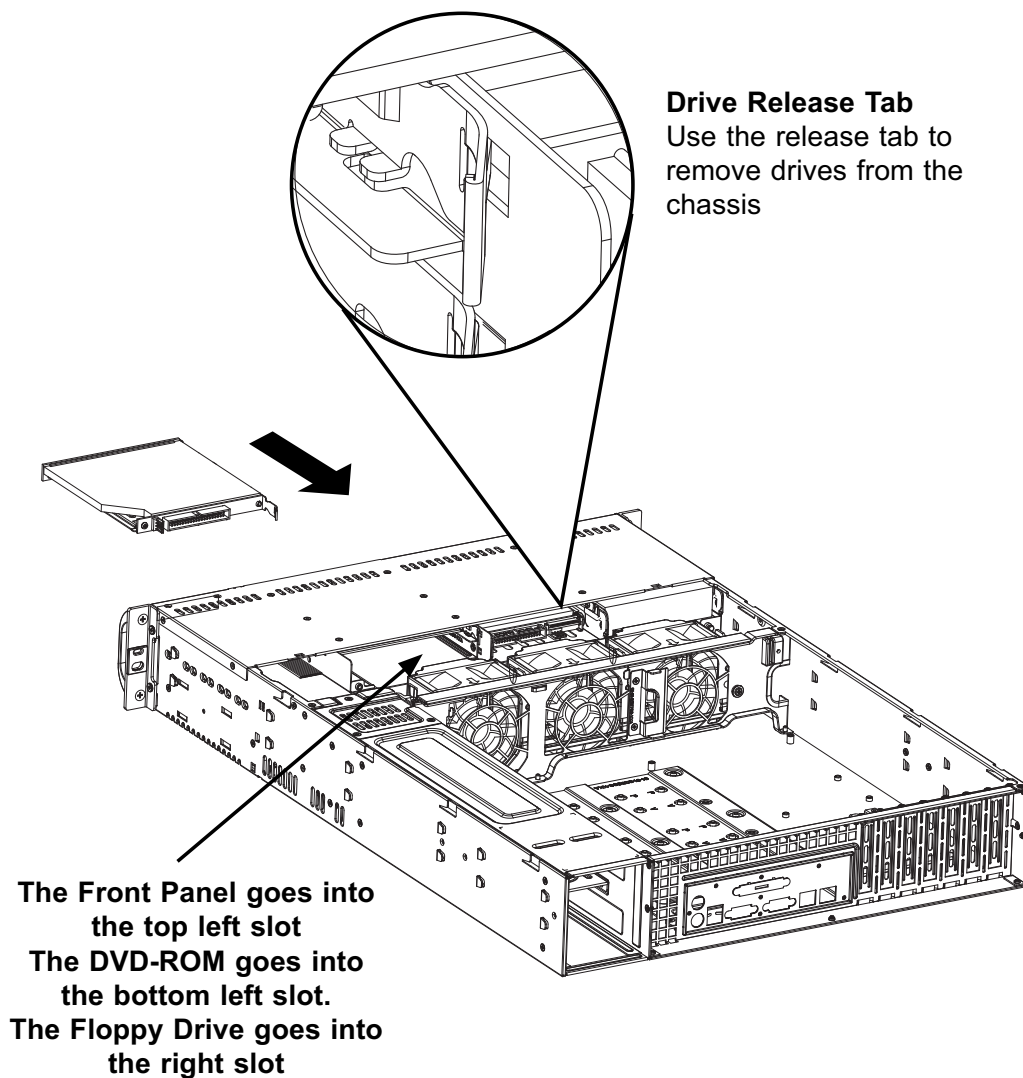

Figure 5-20: Install the DVD-ROM, Front Panel, and Floppy Drive

To replace or install the DVD drive

1. Power down and unplug the system from the outlet.
2. Remove the chassis cover.
3. Disconnect the power and data cables from the drive to other chassis components including the motherboard and backplane.
4. Remove the old drive by depressing the release tab, then pulling the drive out of the chassis.
5. Insert the new drive unit in the slot until the tab locks into place.
6. Connect the data and power cables to the backplane and motherboard.

For more information, see the manual for your backplane in the appendix.

To replace or install the Floppy drive

1. Power down and unplug the system
2. Remove the chassis cover.
3. Disconnect the power and data cables from the drive to other chassis components including the motherboard and backplane.
4. Remove the old drive by depressing the release tab, then pulling the drive out of the chassis.
5. Insert the new drive unit in the slot until the tab locks into place.
6. Connect the data and power cables to the backplane and, if necessary, motherboard.

For more information, see the manual for your backplane in the appendix.

To replace or install the Front Port Panel

1. Power down and unplug the system
2. Remove the chassis cover.
3. Disconnect the power and data cables from the front port panel to other chassis components including the motherboard and backplane.
4. Remove the old port panel by depressing the release tab, then pulling the unit out of the chassis.
5. Insert the new front port panel unit in the slot until the tab locks into place.
6. Connect the data and power cables to the backplane and motherboard.

For more information, see the manual for your backplane in the appendix. For more information, see the manual for your backplane in the appendix.

Notes

Chapter 6:

Rack Installation

6-1 Overview

This chapter provides a quick setup checklist to get your chassis up and running. Following these steps in the order given should enable you to have the system operational within a minimum amount of time.

6-2 Unpacking the System

You should inspect the box the chassis was shipped in and note if it was damaged in any way. If the chassis itself shows damage you should file a damage claim with the carrier who delivered it.

Decide on a suitable location for the rack unit that will hold your chassis. It should be situated in a clean, dust-free area that is well ventilated. Avoid areas where heat, electrical noise and electromagnetic fields are generated. You will also need it placed near a grounded power outlet. Be sure to read the Rack and Server Precautions in the next section.

6-3 Preparing for Setup

The box your chassis was shipped in should include two sets of rail assemblies, two rail mounting brackets and the mounting screws you will need to install the system into the rack. Please read this section in its entirety before you begin the installation procedure outlined in the sections that follow.

Choosing a Setup Location

- Leave enough clearance in front of the rack to enable you to open the front door completely (~25 inches).
- Leave approximately 30 inches of clearance in the back of the rack to allow for sufficient airflow and ease in servicing.
- This product is for installation only in a Restricted Access Location (dedicated equipment rooms, service closets and the like).



Warnings and Precautions!



Rack Precautions

- Ensure that the leveling jacks on the bottom of the rack are fully extended to the floor with the full weight of the rack resting on them.
- In single rack installation, stabilizers should be attached to the rack.
- In multiple rack installations, the racks should be coupled together.
- Always make sure the rack is stable before extending a component from the rack.
- You should extend only one component at a time - extending two or more simultaneously may cause the rack to become unstable.

General Server Precautions

- Review the electrical and general safety precautions that came with the components you are adding to your chassis.
- Determine the placement of each component in the rack *before* you install the rails.
- Install the heaviest server components on the bottom of the rack first, and then work up.
- Use a regulating uninterruptible power supply (UPS) to protect the server from power surges, voltage spikes and to keep your system operating in case of a power failure.
- Allow the hot plug hard drives and power supply modules to cool before touching them.
- Always keep the rack's front door and all panels and components on the servers closed when not servicing to maintain proper cooling.

Rack Mounting Considerations

Ambient Operating Temperature

If installed in a closed or multi-unit rack assembly, the ambient operating temperature of the rack environment may be greater than the ambient temperature of the room. Therefore, consideration should be given to installing the equipment in an environment compatible with the manufacturer's maximum rated ambient temperature (T_{mra}).

Reduced Airflow

Equipment should be mounted into a rack so that the amount of airflow required for safe operation is not compromised.

Mechanical Loading

Equipment should be mounted into a rack so that a hazardous condition does not arise due to uneven mechanical loading.

Circuit Overloading

Consideration should be given to the connection of the equipment to the power supply circuitry and the effect that any possible overloading of circuits might have on overcurrent protection and power supply wiring. Appropriate consideration of equipment nameplate ratings should be used when addressing this concern.

Reliable Ground

A reliable ground must be maintained at all times. To ensure this, the rack itself should be grounded. Particular attention should be given to power supply connections other than the direct connections to the branch circuit (i.e. the use of power strips, etc.).

6-4 Rack Mounting Instructions

This section provides information on installing the SC825 chassis into a rack unit with the rails provided. There are a variety of rack units on the market, which may mean the assembly procedure will differ slightly. You should also refer to the installation instructions that came with the rack unit you are using.

NOTE: This rail will fit a rack between 26" and 33.5" deep.

Identifying the Sections of the Rack Rails

The chassis package includes two rack rail assemblies in the rack mounting kit. Each assembly consists of two sections: an inner fixed chassis rail that secures directly to the server chassis and an outer fixed rack rail that secures directly to the rack itself.

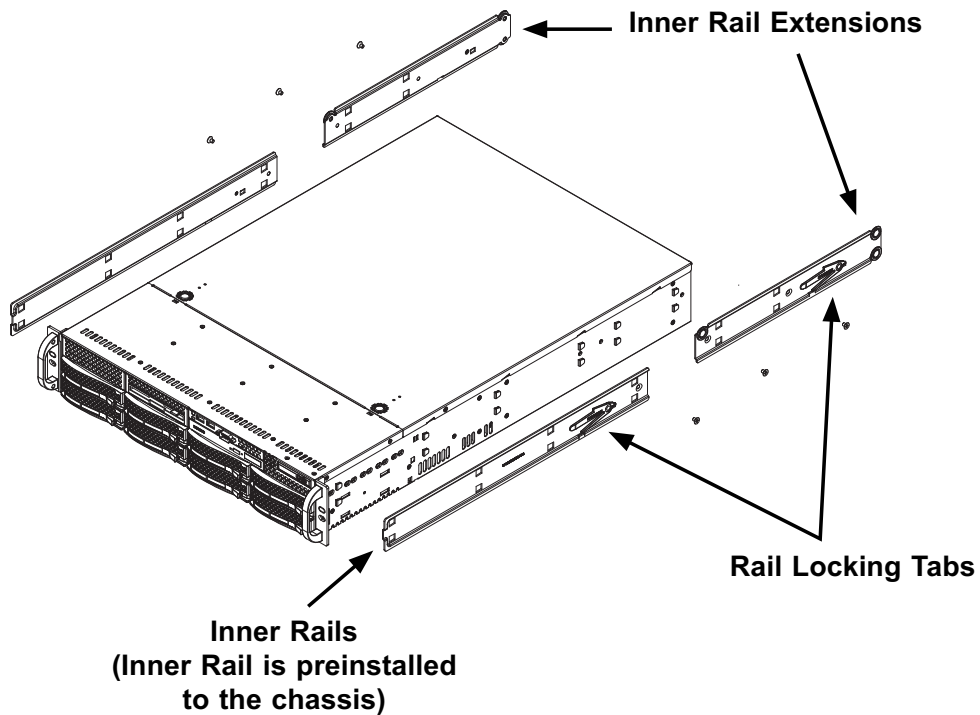
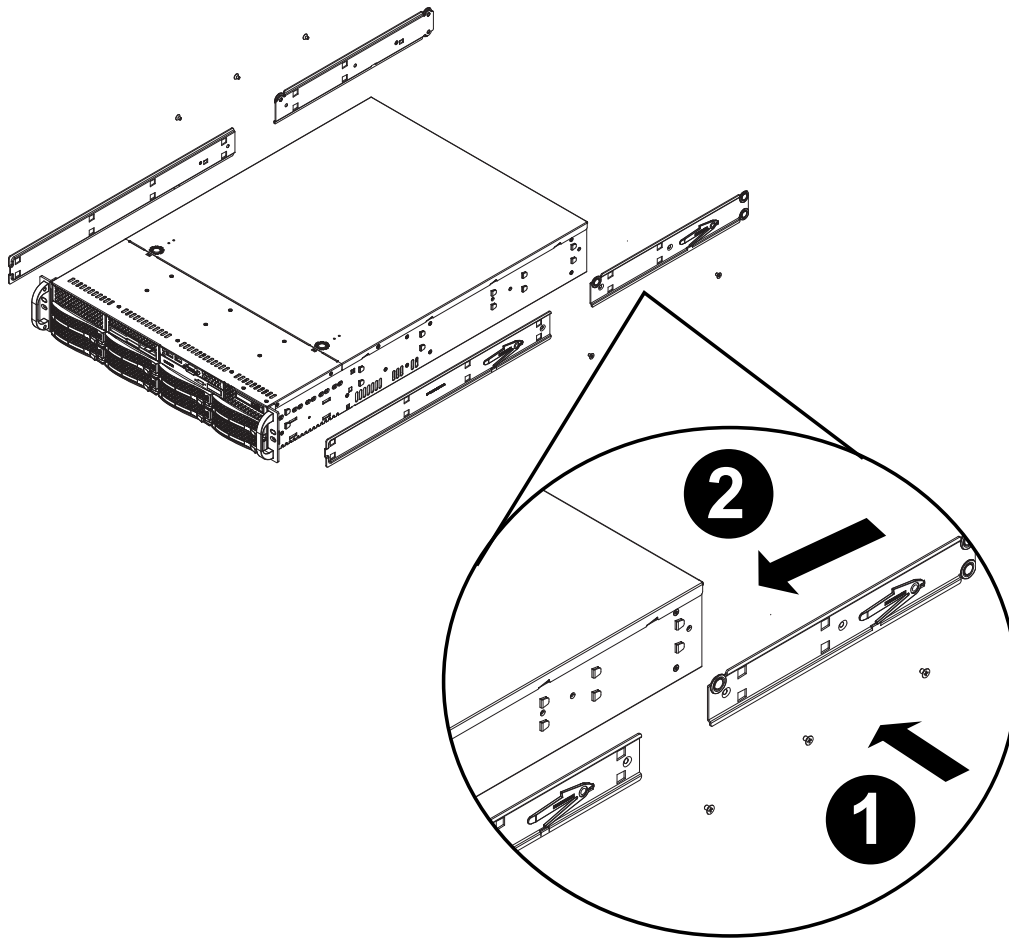

Figure 6-1. Identifying the Sections of the Rack Rails

Locking Tabs

Both chassis rails have a locking tab. The tabs lock the server into place when installed and pushed fully into the rack. These tabs also lock the server in place when fully extended from the rack. This prevents the server from coming completely out of the rack when you pull it out for servicing.



**Figure 6-2. Identifying the Sections of the Rack Rails
(right side rail shown)**

Installing the Inner Rail Extension

The SC825 chassis includes a set of inner rails in two sections: inner rails and inner rail extensions. The inner rails are pre-attached and do not interfere with normal use of the chassis if you decide not to use a server rack. Attach the inner rail extension to stabilize the chassis within the rack.

To install the inner rails

1. Place the inner rack extensions on the side of the chassis aligning the hooks of the chassis with the rail extension holes. Make sure the extension faces "outward" just like the pre-attached inner rail.
2. Slide the extension toward the front of the chassis.
3. Secure the chassis with 2 screws as illustrated. Repeat steps for the other inner rail extension.

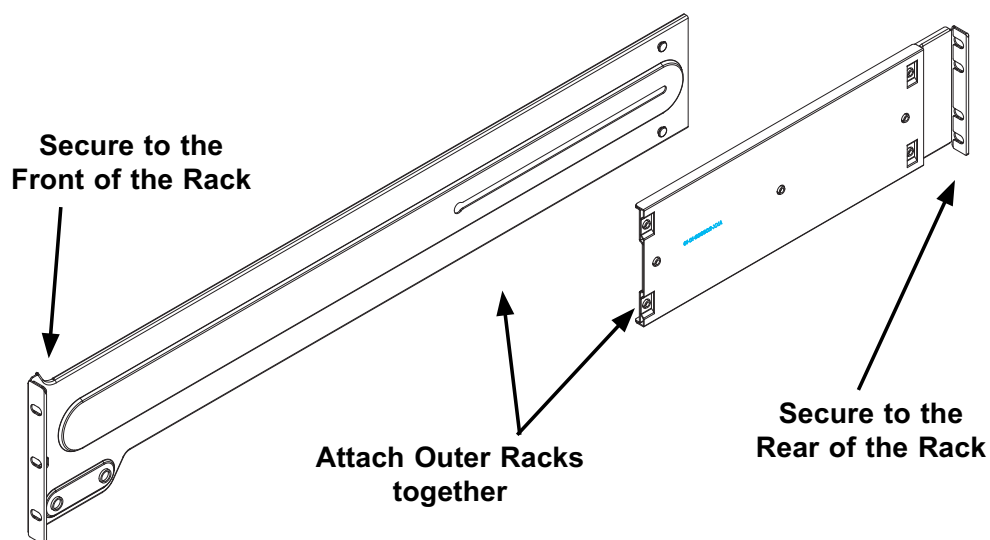

Figure 6-3. Assembling the Outer Rails

Outer Rack Rails

Outer rails attach to the server rack and hold the server in place. The outer rails for the SC836 chassis extend between 30 inches and 33 inches.

Installing the outer rails to the rack

1. Attach the short bracket to the outside of the long bracket. You must align the pins with the slides. Also, both bracket ends must face the same direction.
2. Adjust both the short and long brackets to the proper distance so that the rail fits snugly into the rack.
3. Secure the long bracket to the front side of the outer rail with two M5 screws and the short bracket to the rear side of the outer rail with three M5 screws.
4. Repeat steps 1-4 for the left outer rail.

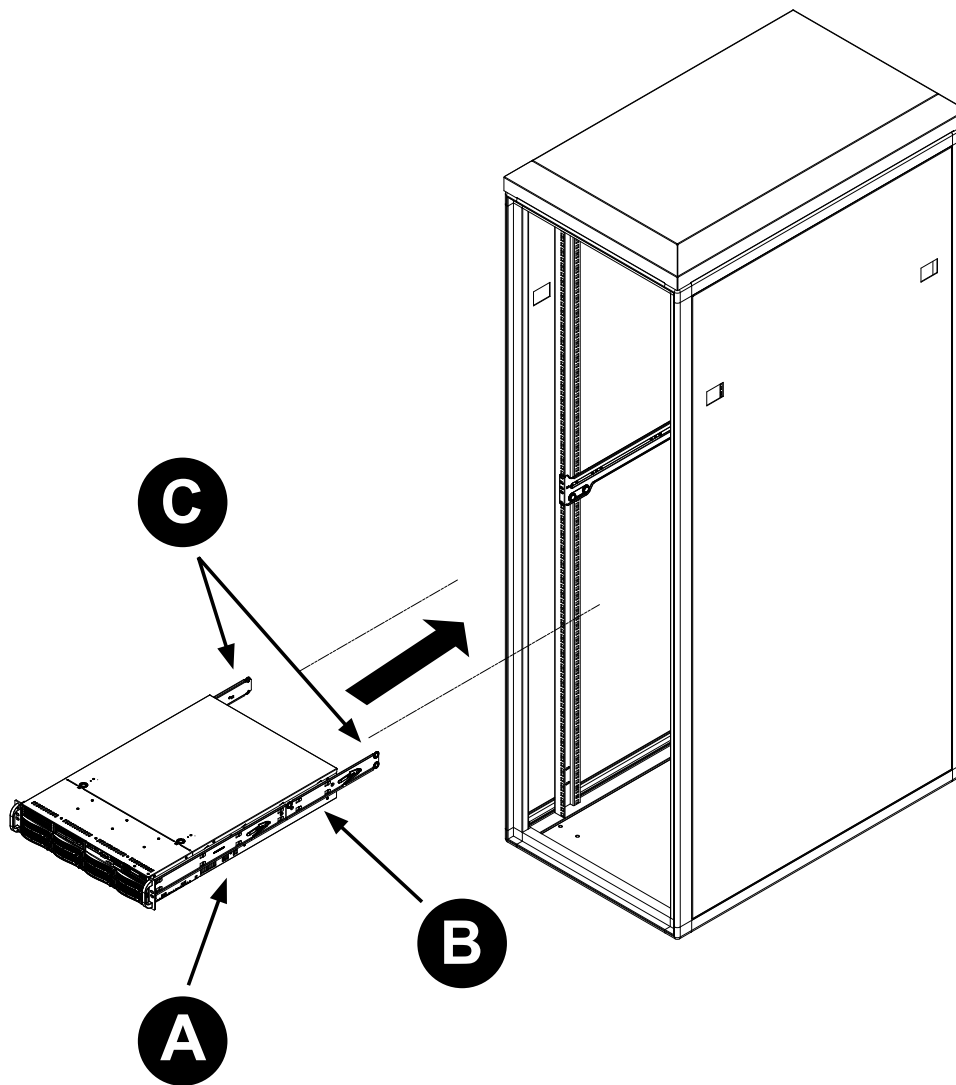

Figure 6-4: Installing the Rack Rails

Installing the chassis into a rack

1. Confirm that chassis includes the inner rails (A) and rail extensions (B). Also, confirm that the outer rails (C) are installed on the rack.
2. Line chassis rails (A and B) with the front of the rack rails (C).
3. Slide the chassis rails into the rack rails, keeping the pressure even on both sides (you may have to depress the locking tabs when inserting). When the server has been pushed completely into the rack, you should hear the locking tabs "click".
4. (Optional) Insert and tightening the thumbscrews that hold the front of the server to the rack.

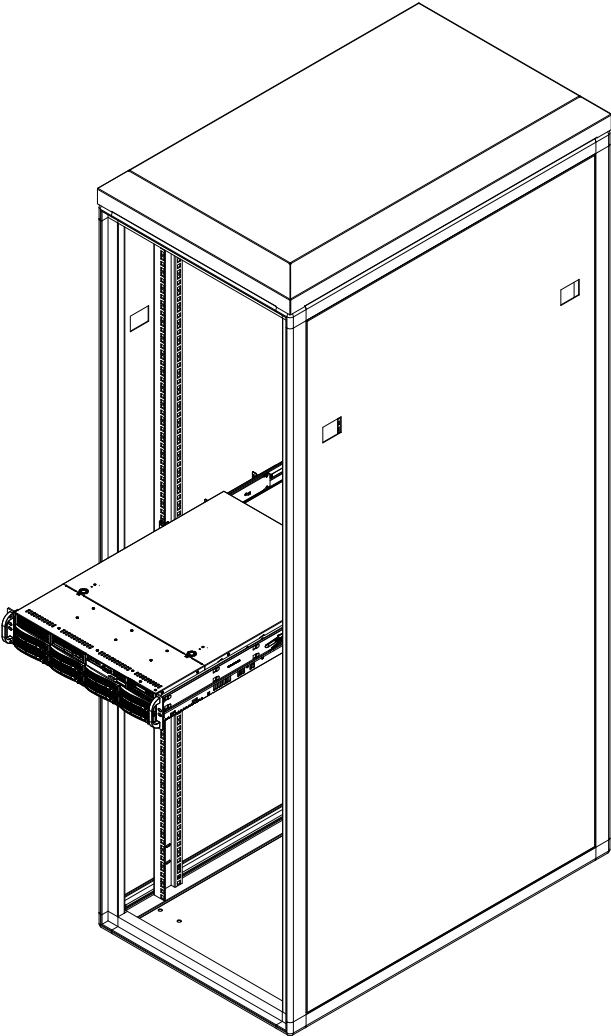

Figure 6-5. Fully installed SC825 Chassis

Appendices

Appendix A: Compatible Cables

Appendix B: SC825 Power Supply Specifications

Appendix C: SAS 825TQ Backplane Manual

Appendix D: SAS 825S2 Backplane Manual

Notes

Appendix A:

SC825 Chassis Cables

A-1 Overview

This appendix lists supported cables for your chassis system. It only includes the most commonly used components and configurations. For more compatible cables, refer to the manufacturer of the motherboard you are using and our Web site at: www.supermicro.com.

A-2 Cables Included with SC825TQ Universal I/O Chassis

SC825TQ-R700U			
Part #	Type	Length	Description
CBL-0157L	Cable	9"	8 pin to 8 pin ribbon cable for SGPIO, PB free
CBL-0087	Ribbon, Round	20"	16 pin to 16 pin ribbon cable for control panel
CBL-0139L	Wire	50 cm	IDE 80-Wire cable for DVD ROM
-	Cable	6'	Two regional power cords
CBL-0180L-01	SATA	various	Set for 4 SATA Cables. Length varied to minimize airflow interference.
CBL-0078	Cable	45 cm	Round floppy cable

A-3 Cables Included with SC825TQ Chassis (SAS/SATA)

SC825TQ-R700RC2/R700RC			
Part #	Type	Length	Description
CBL-0157L	Cable	9"	8 pin to 8 pin ribbon cable for SGPIO, PB free
CBL-0191L	Cable	50 cm	20 pin to 20 pin cable for control panel
CBL-0139L	Wire	50 cm	IDE 80-Wire cable for DVD ROM
-	Cable	6'	Two regional power cords
CBL-0180L	SATA	various	Set for 4 SATA Cables. Length varied to minimize airflow interference.
CBL-0078	Cable	45 cm	Round floppy cable

SC825TQ-R700LP			
Part #	Type	Length	Description
CBL-0157L	Ribbon	9"	8 pin to 8 pin ribbon cable for SGPIO, PB free
CBL-0087	Ribbon, Round	20"	16 pin to 16 pin ribbon cable for control panel
CBL-0139L	Wire	50 cm	IDE 80-Wire cable for DVD ROM
-	Cable	6'	Two regional power cords
CBL-0180L-01	SATA	various	Set for 4 SATA Cables. Length varied to minimize airflow interference.

SC825TQ-560LP			
Part #	Type	Length	Description
CBL-0157L	Ribbon	9"	8 pin to 8 pin ribbon cable for SGPIO, PB free
CBL-0087	Ribbon, Round	20"	16 pin to 16 pin ribbon cable for control panel
CBL-0139L	Wire	60 cm	IDE 80-Wire cable for DVD ROM
-	Cable	6'	Regional power cord
CBL-0180L	SATA	various	Set for 4 SATA Cables. Length varied to minimize airflow interference.

A-4 Cables Included with SC825S2 Chassis (SCSI)

SC825S2-R700RC2/R700RC			
Part #	Type	Length	Description
CBL-033L-U320	Ribbon	9" (23 cm)	ULTRA 320, PB FREE
CBL-0139L	Wire	50 cm	IDE 80-Wire cable for DVD ROM
-	Cable	6'	Two regional power cord
CBL-0063L	Cable	20"	SCSI Cable for SC811S-350

SC825S2-R700LP			
Part #	Type	Length	Description
CBL-033L-U320	Ribbon	9" (23 cm)	ULTRA 320, PB FREE
CBL-0139L	Wire	50 cm	IDE 80-Wire cable for DVD ROM
-	Cable	6'	Regional power cord
CBL-0063L	Cable	20"	SCSI Cable for SC811S-350

SC825S2-R560LP			
Part #	Type	Length	Description
CBL-033L-U320	Ribbon	9" (23 cm)	ULTRA 320, PB FREE
CBL-0139L	Wire	50 cm	16 pin to 16 pin ribbon cable for control panel
-	Cable	6'	IDE 80-Wire cable for DVD ROM
CBL-0063L	Cable	20"	Regional power cord

Notes

A-5 Compatible Cables

These cables are compatible with the SC825 Chassis.

Alternate SAS/SATA Cables

Some compatible motherboards have different connectors. If your motherboard has only one SAS connector that the SAS/SATA cables must share, use one of the following cables. These cables must be purchased separately.

Cable Name: SAS Cable

Quantity: 1

Part #: CBL-0175L

Alt. Name: "Big Four"

Description: This cable has one SFF-8484 (32 pin) connector on one end and 4 SAS connectors (7 pins each) at the other. This cable connects from the Host (motherboard or other controller) to the backplane SAS hard drive port.

Cable Name: SAS Cable

Quantity: 1

Part #: CBL-0116

Alt. Name: iPass or "Small Four"

Description: This cable has one ipass (SFF-8087/mini-sas) connector (36 pins) at one end and 4 SAS connectors on one end. This cable connects from the Host (motherboard or other controller) to the backplane SAS hard drive port.

Extending Power Cables

Although Super Micro chassis are designed to be efficient and cost-effective, some compatible motherboards have power connectors located in different areas.

To use these motherboards you may have to extend the power cables to the motherboards. To do this, use the following chart as a guide.

Power Cable Extenders		
Number of Pins	Cable Part #	Length
24 pin	CBL - 0042	7.9”(20 CM)
20 pin	CBL - 0059	7.9”(20 CM)
8 pin	CBL - 0062	7.9”(20 CM)
4 pin	CBL - 0060	7.9”(20 CM)

Front Panel to the Motherboard

The SC825 chassis includes a cable to connect the chassis front panel to the motherboard. If your motherboard uses a different connector, use the following list to find a compatible cable.

Front Panel to Motherboard Cable (Ribbon Cable)		
Number of Pins (Front Panel)	Number of Pins (Motherboard)	Cable Part #
16 pin	16 pin	CBL - 0049
16 pin	20 pin	CBL - 0048
20 pin	20 pin	CBL - 0047
16 pin	various*	CBL - 0068
20 pin	various*	CBL - 0067

* Split Cables: Use these cable if your motherboard requires several different connections from the front panel.

Appendix B:

SC825 Power Supply Specifications

This appendix lists power supply specifications for your chassis system.

	700W	560W
MFR Part #	PWS-0065	PWS-561-1H20
Rated AC Voltage	100 - 240V 50 - 60Hz 9.5 - 4.5 Amp	100 - 240V 50 - 60Hz 8.5 - 4 Amp
+5V standby	4 Amp	3 Amp
+12V	58 Amp	43.6 Amp
+5V	24 Amp	25 Amp
+3.3V	21 Amp	21 Amp
-12V	0.6 Amp	0.6 Amp

Notes

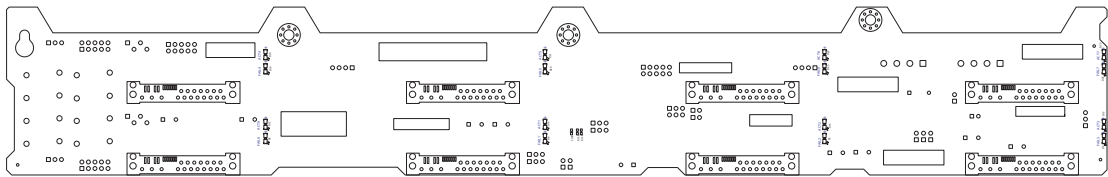

SAS 825TQ Backplane

USER'S GUIDE

Rev. 1.0

Table of Contents

Chapter 1: Safety Guidelines

1-1	ESD Safety Guidelines	1-1
1-2	General Safety Guidelines.....	1-1
1-3	An Important Note to Users.....	1-1

Chapter 2: Jumper Settings and Pin Definitions

2-1	Front Connectors and Jumpers	2-1
2-2	Front Connector Pin Definitions	2-2
2-3	Front Jumper Locations and Pin Definitions	2-4
2-4	Rear Connectors and LED Indicators	2-6

User's Guide Revision: Rev. 1.0a
Release Date: 09/29/2006

Chapter 1

Safety Guidelines



To avoid personal injury and property damage, carefully follow all the safety steps listed below when accessing your system or handling the components.

1-1 ESD Safety Guidelines

Electric Static Discharge (ESD) can damage electronic components. To prevent damage to your system, it is important to handle it very carefully. The following measures are generally sufficient to protect your equipment from ESD.

- Use a grounded wrist strap designed to prevent static discharge.
- Touch a grounded metal object before removing a component from the antistatic bag.
- Handle the RAID card by its edges only; do not touch its components, peripheral chips, memory modules or gold contacts.
- When handling chips or modules, avoid touching their pins.
- Put the card and peripherals back into their antistatic bags when not in use.

1-2 General Safety Guidelines

- Always disconnect power cables before installing or removing any components from the computer, including this backplane.
- Disconnect the power cable before installing or removing any cables from this backplane.
- Make sure that the this backplane is securely and properly installed on the motherboard to prevent damage to the system due to power shortage.

1-3 An Important Note to Users

- All images and layouts shown in this user's guide are based upon the latest PCB Revision available at the time of publishing. The card you have received may or may not look exactly the same as the graphics shown in this manual.

Notes

Chapter 2

Jumper Settings and Pin Definitions

2-1 Front Connectors and Jumpers

Front View

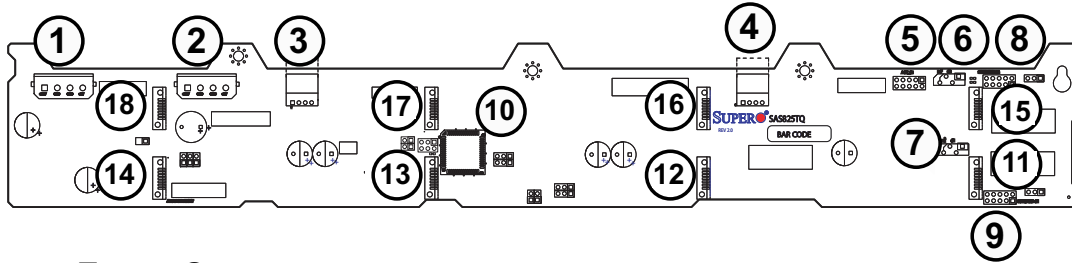

Front Connectors

- #1. JP13: 4-Pin PWR Connector
- #2. JP10: 4-Pin PWR Connector
- #3. J18: CD-ROM/Floppy PWR Connector
- #4. J17: CD-ROM/Floppy PWR Connector
- #5. JP26: Activity In LED Header
- #6. JP45: I²C Connector#2
- #7. JP44: I²C Connector#1
- #8. JP52: SideBand #2
- #9. JP51: SideBand #1
- #10. MG 9072 Chip
- #11. SAS Port #0
- #12. SAS Port #1
- #13. SAS Port #2
- #14. SAS Port #3
- #15. SAS Port #4
- #16. SAS Port #5
- #17. SAS Port #6
- #18. SAS Port #7

2-2 Front Connector and Pin Definitions

#1/#2. Backplane Main Power Connectors

The 4-pin connectors, designated JP10 and JP13, provide power to the backplane. See the table on the right for pin definitions.

Backplane Main Power 4-Pin Connector (JP10 and JP13)	
Pin#	Definition
1	+12V
2 and 3	Ground
4	+5V

#3/#4. CD-ROM/Floppy 4-Pin Connectors

The 4-pin connectors, designated J17 and J18, provide power to the CD-ROM and floppy drives. See the table on the right for pin definitions.

CD-ROM/FDD Power 4-Pin Connector (J17 and J18)	
Pin#	Definition
1	+5V
2 and 3	Ground
4	+12V

#5. Activity LED Header

The activity LED header, designated JP26, is used to indicate the activity status of each SAS drive. The Activity LED Header is located on the front panel. For the Activity LED Header to work properly, connect using a 10-pin LED cable.

SAS Activity LED Header Pin Definitions (JP26)			
Pin #	Definition	Pin #	Definition
1	ACT IN#0	6	ACT IN#4
2	ACT IN#1	7	ACT IN#5
3	ACT IN#2	8	ACT IN#6
4	ACT IN#3	9	ACT IN#7
5	Ground	10	Empty

#6/#7. I²C Connectors

The I²C Connectors, designated JP44 and JP45, are used to monitor HDD activity and status. See the table on the right for pin definitions.

I ² C Connector Pin Definitions (JP44 and JP45)	
Pin#	Definition
1	Data
2	Ground
3	Clock
4	No Connection

#8/#9. Sideband Headers

The sideband headers are designated JP51 and JP52. For SES-2 to work properly, you must connect an 8-pin sideband cable to JP51 and JP52. See the table to the right for pin definitions.

Sideband Headers (JP51 and JP52)			
Pin #	Definition	Pin #	Definition
2	Backplane Addressing (SB5)	1	Controller ID (SB6)
4	Reset (SB4)	3	GND (SB2)
6	GND (SB3)	5	SDA (SB1)
8	Backplane ID (SB7)	7	SCL (SB0)
10	No Connection	9	No Connection

#10. MG9072 Chip

The MG9072 is an enclosure management chip that supports the SES-2 controller and SES-2 protocols.

#11-#18. SAS Ports

The SAS ports are used to connect the SAS drive cables. The 8 ports are designated #0 - #7.

2-3 Front Jumper Locations and Pin Definitions

Front Jumper Locations

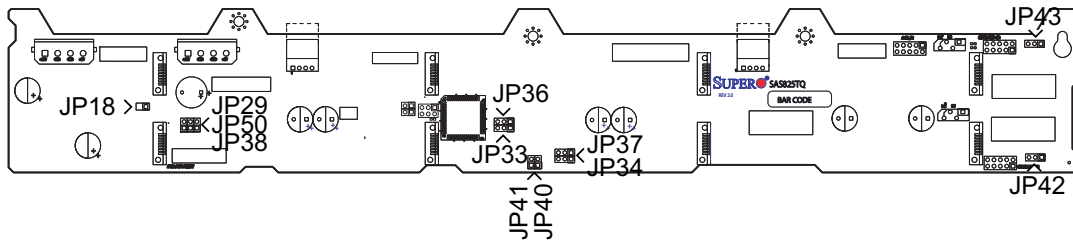

I²C and SGPIO Modes and Jumper Settings

This backplane can utilize I²C or SGPIO. I²C is the default mode and can be used without making changes to your jumpers. The following information details which jumpers must be configured to use SGPIO Settings or restore your backplane to I²C mode.

I ² C Setting (Default)		
Jumper	Jumper Setting	Note
JP18	Open	Closed: Buzzer Reset (Default)
JP29	Open	Closed: MG9072 Reset (Default)
JP33	2-3	Controller ID #1
JP34	1-2	Backplane ID #1 1-2: ID#0 2-3: ID#1
JP36	2-3	Controller ID #2
JP37	2-3	Backplane ID #2 1-2: ID#0 2-3: ID#1
JP38	On	I ² C Reset #2
JP40	Off	I ² C Reset _SDOUT#1
JP41	Off	I ² C Reset _SDOUT#2
JP42	2-3	I ² C Backplane ID _SDIN#1
JP43	2-3	I ² C Backplane ID _SDIN#2
JP50	On	I ² C Reset #1

SGPIO Setting (Only)		
Jumper	Jumper Setting	Note
JP18	Open	Closed: Buzzer Reset (Default)
JP29	Open	Closed: MG9072 Reset (Default)
JP33	1-2	Controller ID #1
JP34*	1-2	Backplane ID #1 1-2: ID#0 2-3: ID#1
JP36	1-2	Controller ID #2
JP37*	2-3	Backplane ID #2 1-2: ID#0 2-3: ID#1
JP38	Off	I ² C Reset #2
JP40	On	I ² C Reset _SDOUT#1
JP41	On	I ² C Reset _SDOUT#2
JP42	1-2	I ² C Backplane ID _SDIN#1
JP43	1-2	I ² C Backplane ID _SDIN#2
JP50	Off	I ² C Reset #1

***NOTE:** For SGPIO setting to work properly, use different backplane ID's for JP34 and JP37. When JP34 is set to 1-2 (ID#0), set JP37 to 2-3 (ID#1). Conversely, when JP34 is set to 2-3 (ID#1), set JP37 to 1-2 (ID#0).

SAS Port Connections in I²C and SGPIO Settings

Use the following rules when connecting this backplane:

- I²C #1 corresponds with SAS ports #0, #1, #2, and #3. I²C #2 corresponds with SAS ports #4, #5, #6, and #7. If you connect the SAS ports out of order, you will not be able to easily identify drives using the LED function.
- JP51 (Sideband #1) corresponds with SAS ports #0, #1, #2, and #3. JP52 (Sideband #2) corresponds with SAS ports #4, #5, #6, and #7. If you connect the SAS ports out of order, you will not be able to easily identify drives using the LED function.

2-4 Rear Connectors and LED Indicators

Rear Connector Locations

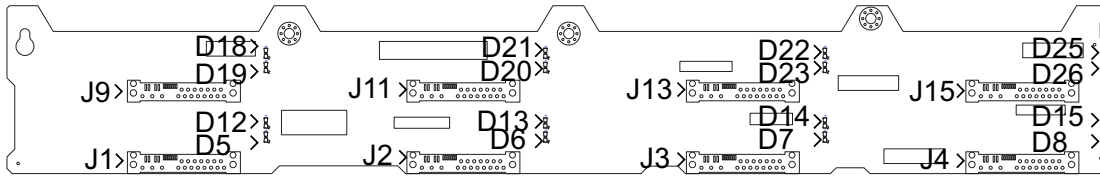

Rear Connector/LED Indicator Descriptions

825TQ SAS Connectors	
Connector	Specification
J1	SAS#0 HDD (connected to HDD)
J2	SAS#1 HDD (connected to HDD)
J3	SAS#2 HDD (connected to HDD)
J4	SAS#3 HDD (connected to HDD)
J9	SAS#4 HDD (connected to HDD)
J11	SAS#5 HDD (connected to HDD)
J13	SAS#6 HDD (connected to HDD)
J15	SAS#7 HDD (connected to HDD)

Rear LED Indicators	Specification
D12	SAS#0 Activity LED
D13	SAS#1 Activity LED
D14	SAS#2 Activity LED
D15	SAS#3 Activity LED
D18	SAS#4 Activity LED
D21	SAS#5 Activity LED
D22	SAS#6 Activity LED
D25	SAS#7 Activity LED
D5	SAS#0 Failure LED
D6	SAS#1 Failure LED
D7	SAS#2 Failure LED
D8	SAS#3 Failure LED
D19	SAS#4 Failure LED
D20	SAS#5 Failure LED
D23	SAS#6 Failure LED
D26	SAS#7 Failure LED

SUPER[®]

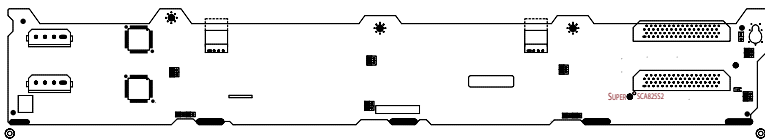

SCA825S2 Backplane

USER'S GUIDE

Rev. 1.0

Table of Contents

Safety Information and Technical Specifications	1-3
1. Safety Guidelines	1-3
2. Jumper Settings and Pin Definitions	1-4
A. Front Jumpers and Connectors	1-4
A-1. Front Jumper/Connector Locations	1-5
A-2. Front Connectors and Pin Descriptions	1-5
A-3. Backplane Front Jumpers	1-7
A-4. Backplane Front LEDs	1-7
B. Rear Connectors and LED Indicators	1-8
B-1. Rear Connector/LED Indicator Locations.....	1-8
B-2. Rear Connector/LED Indicator Descriptions	1-8
3. SCSI (Super) GEM Installation Instructions for the Windows Operating System	1-9

User's Guide Revision: Rev. 1.0
Release Date: 07/25/2006

Safety Information and Technical Specifications

1. Safety Guidelines



To avoid personal injury and property damage, please carefully follow all the safety steps listed below when accessing your system or handling the components:

ESD Safety Guidelines

Electric Static Discharge (ESD) can damage electronic components. To prevent damage to your system, it is important to handle it very carefully. The following measures are generally sufficient to protect your equipment from ESD.

- Use a grounded wrist strap designed to prevent static discharge.
- Touch a grounded metal object before removing a component from the antistatic bag.
- Handle the RAID card by its edges only; do not touch its components, peripheral chips, memory modules or gold contacts.
- When handling chips or modules, avoid touching their pins.
- Put the card and peripherals back into their antistatic bags when not in use.

General Safety Guidelines

- Always disconnect power cables before installing or removing any components from the computer, including the SCA825S2 Backplane.
- Disconnect the power cable before installing or removing any cable from the SCA825S2 Backplane.
- Make sure that the SCA825S2 Backplane is securely and properly installed on the motherboard to prevent damage to the system due to power shortage.

An Important Note to the User

- All images and layouts shown in this user's guide are based upon the latest PCB Revision available at the time of publishing. The card you've received may or may not look exactly the same as the graphics shown in this manual.

2. Jumper Settings and Pin Definitions

A. Front Jumpers and Connectors

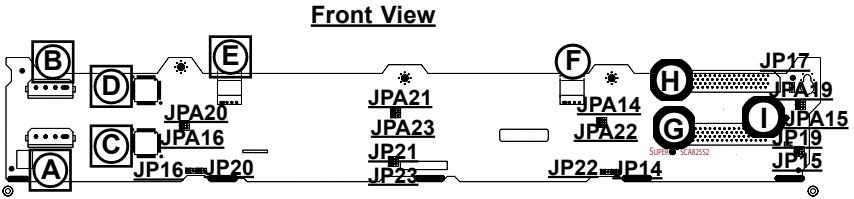

Front Jumper/Connector Locations

Front Panel Connectors

- A/B. JP10/JPA10: Backplane Main (4-Pin) PWR Connectors
- C/D. GEM318
- E/F. CD-ROM/Floppy Drive (4-Pin) PWR Connectors
- G. LVD1 SCSI Channel A
- H. LVDA1 SCSI Channel B
- I. D4: Overheat/Drive Fail LED Indicator

Front Panel Jumpers

(*See A-2 on Page 1-7)

Front Panel LED (D4)

(*See A-3 on Page 1-7)

A-2. Front Panel Connectors and Pin Definitions

A/B : SCA825S2 Backplane Main Power (JP10/JPA10)

Backplane Main Power Connector Pin Definitions

You must use the 4-pin power connectors (JP10/JPA10) to provide adequate power supply to the Backplane. See the table on the right for pin definitions.

Backplane Main PWR 4-pin Connector	
Pins #	Definition
1	+12 V
2 & 3	Ground
4	+5V

C/D: GEM 318 (SAF-TE: SCSI Accessed Fault-Tolerant Enclosures)

This chip allows the system to use a set of pre-defined SCSI commands to monitor the status of disk drives and provide disk drive information to the user through LED indicators and buzzers. (*Note: This function is available only when a RAID controller with a RAID set is present and enabled. Please refer to the table below for the information on SAF-TE LED Indicators.)

SAF-TE LED Indicators

LED#	Location	Description
D4	Front	Overheat or Drive Failure (red light flashing, buzzer: on)
D5	Rear	Channel A ID#0 Failure LED (red light flashing, buzzer: on)
DA5	Rear	Channel B ID#0 Failure LED (red light flashing, buzzer: on)
D6	Rear	Channel A ID#1 Failure LED (red light flashing, buzzer: on)
DA6	Rear	Channel B ID#1 Failure LED (red light flashing, buzzer: on)
D16	Rear	Channel A ID#2 Failure LED (red light flashing, buzzer: on)
DA16	Rear	Channel B ID#2 Failure LED (red light flashing, buzzer: on)
D18	Rear	Channel A ID#3 Failure LED (red light flashing, buzzer: on)
DA18	Rear	Channel B ID#3 Failure LED (red light flashing, buzzer: on)

E/F: CD-ROM/Floppy Drive Power Connectors

CD-ROM/FDD Power Connector Pin Definitions

You must use the 4-pin power connectors to provide power supply to the CD-ROM and Floppy Drives. See the table on the right for pin definitions.

CD-ROM/FDD PWR 4-pin Connectors	
Pins #	Definition
1	+5 V
2 & 3	Ground
4	+12V

G/H: Ultra 320 SCSI Connectors (LVD1/LVDA1)

SCSI Connector Pin Definitions

There are two Ultra 320 SCSI connectors on the backplane. SCSI Channel A is located at LVD1 and Channel B is located on LVDA1. Refer to the table below for the pin definitions for the SCSI connectors.

Ultra320 SCSI Drive Connector Pin Definitions			
Pin#	Definition	Pin #	Definition
1	+DB (12)	35	-DB (12)
2	+DB (13)	36	-DB (13)
3	+DB (14)	37	-DB (14)
4	+DB (15)	38	-DB (15)
5	+DB (P1)	39	-DB (P1)
6	+DB (0)	40	-DB (0)
7	+DB (1)	41	-DB (1)
8	+DB (2)	42	-DB (2)
9	+DB (3)	43	-DB (3)
10	+DB (4)	44	-DB (4)
11	+DB (5)	45	-DB (5)
12	+DB (6)	46	-DB (6)
13	+DB (7)	47	-DB (7)
14	+DB (P)	48	-DB (P)
15	Ground	49	Ground
16	DIFFSENS	50	Ground
17	TERMPWR	51	TERMPWR
18	TERMPWR	52	TERMPWR
19	Reserved	53	Reserved
20	Ground	54	Ground
21	+ATN	55	-ATN
22	Ground	56	Ground
23	+BSY	57	-BSY
24	+ACK	58	-ACK
25	+RST	59	-RST
26	+MSG	60	-MSG
27	+SEL	61	-SEL
28	+C/D	62	-C/D
29	+REQ	63	-REQ
30	+I/O	64	-I/O
31	+DB (8)	65	-DB (8)
32	+DB (9)	66	-DB (9)
33	+DB (10)	67	-DB (10)
34	+DB (11)	68	-DB (11)

A-2. Backplane Front Jumpers

Front Jumper Descriptions and Pin Definitions

Jumper	Description	Definition
JP17	On (*Default)	Buzzer Enable
	Off	Buzzer Disable
JP16	On	Remote Start-Channel A#3 Enable
	Off (*Default)	Remote Start- Channel A#3 Disable
JP20	On	Delay Start- Channel A#3 Enable
	Off (*Default)	Delay Start- Channel A#3 Disable
JPA16	On	Remote Start-Channel B#3 Enable
	Off (*Default)	Remote Start- Channel B#3 Disable
JPA20	On	Delay Start- Channel B#3 Enable
	Off (*Default)	Delay Start- Channel B#3 Disable
JP23	On	Remote Start- Channel A#2 Enable
	Off (*Default)	Remote Start- Channel A#2 Disable
JP21	On	Delay Start- Channel A#2 Enable
	Off (*Default)	Delay Start- Channel A#2 Disable
JPA23	On	Remote Start- Channel B#2 Enable
	Off (*Default)	Remote Start- Channel B#2 Disable
JPA21	On	Delay Start- Channel B#2 Enable
	Off (*Default)	Delay Start- Channel B#2 Disable
JP22	On	Remote Start- Channel A#1 Enable
	Off (*Default)	Remote Start- Channel A#1 Disable
JP14	On	Delay Start- Channel A#1 Enable
	Off (*Default)	Delay Start- Channel A#1 Disable
JPA22	On	Remote Start- Channel B#1 Enable
	Off (*Default)	Remote Start- Channel B#1 Disable
JPA14	On	Delay Start- Channel B#1 Enable
	Off (*Default)	Delay Start- Channel B#1 Disable
JP15	On	Remote Start- Channel A#0 Enable
	Off (*Default)	Remote Start- Channel A#0 Disable
JP19	On	Delay Start- Channel A#0 Enable
	Off (*Default)	Delay Start- Channel A#0 Disable
JPA15	On	Remote Start- Channel B#0 Enable
	Off (*Default)	Remote Start- Channel B#0 Disable
JPA19	On	Delay Start- Channel B#0 Enable
	Off (*Default)	Delay Start- Channel B#0 Disable

A-3. Backplane Front LED

Front Overheat LED Indicator

Front LED Indicator	Specification
D4 (Front)	Overheat/Drive Failure LED Indicator (Red light: flashing, Buzzer: On)

B. Rear Connectors and LED Indicators

B-1 Rear Connector/LED Indicator Locations

Rear View

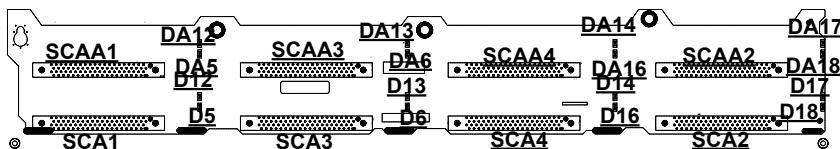

(*See below for rear connector/LED descriptions.)

B-2 Connector/LED Indicator Descriptions

B-2.1 Backplane Rear Connectors

Rear Connector	Specification
SCA1	SCSI Channel A #0
SCA3	SCSI Channel A #1
SCA4	SCSI Channel A #2
SCA2	SCSI Channel A #3
SCAA1	SCSI Channel B #0
SCAA3	SCSI Channel B #1
SCAA4	SCSI Channel B #2
SCAA2	SCSI Channel B #3

B-2.2 Backplane Rear LED Indicators

Rear LED	Specification
D12	SCSI Channel A #0 Activity LED
D13	SCSI Channel A #1 Activity LED
D14	SCSI Channel A #2 Activity LED
D17	SCSI Channel A #3 Activity LED
DA12	SCSI Channel B #0 Activity LED
DA13	SCSI Channel B #1 Activity LED
DA14	SCSI Channel B #2 Activity LED
DA17	SCSI Channel B #3 Activity LED
D5	SCSI Channel A #0 Failure LED
D6	SCSI Channel A #1 Failure LED
D16	SCSI Channel A #2 Failure LED
D18	SCSI Channel A #3 Failure LED
DA5	SCSI Channel B #0 Failure LED
DA6	SCSI Channel B #1 Failure LED
DA16	SCSI Channel B #2 Failure LED
DA18	SCSI Channel B #3 Failure LED

3. SCSI (Super) GEM Installation Instructions for the Windows Operating System

Please refer to the following instructions to install the SCSI GEM Driver for the Windows OS systems.

(*Note: This driver is not necessary for other Operating Systems. If you have two SCA backplanes, you will need to install the driver twice.)

The driver is located on the Super Micro motherboard driver CD or is available for download from our FTP site: <ftp://ftp.supermicro.com/driver/Qlogic/>

Follow the procedure below to install this driver to your system.

Installing the driver:

- 1) Right click on "My Computer" and choose "Property".
- 2) Select "Hardware" tab and click on "Device Manager".
- 3) Open "Other Devices" or wherever "GEM318" is on.
- 4) Right click on this device and choose "Property".
- 5) Click on "Driver" tab and choose "Update Driver".
- 6) Click "Next" 2 times, uncheck both "Floppy disk drives" and "CD-ROM drives". Then, select the item- "Specify a location," and choose "Next".
- 7) Click on "Browse" and choose D drive or wherever Supermicro Setup CD is in.
- 8) Choose "Qlogic" folder and click on "Open".
- 9) System will automatically detect GEM318 and install the drive from this point on.

or,

- 1) Right click the "My Computer" icon on your desktop and choose Properties.
- 2) Click on the Hardware tab and click on "Device Manager" to bring up the list of system devices.
- 3) You may see one or two yellow question marks (?) that read QLogic GEM354 or GEM318 SCSI Processor Device. Right click on these, and choose to uninstall. If two such question marks are present, uninstall both.
- 4) Click on Action tab and choose "Scan for Hardware Changes". The Hardware Wizard program should start up. Click "Next".
- 5) At the first prompt, choose "Display a list of known device drivers for the device so that I can choose a specific driver" and click "Next".
- 6) Choose "Other Devices" and click Next.
- 7) Choose "Have Disk", and specify your floppy drive location in the options box. Then, click "Next".
- 8) Highlight "Enclosure Services Device" and click "Next".
- 9) Ignore the warning prompt by clicking "Yes".

Notes