

UC-SB2-DMK

Display Mounting Kit for Crestron Videobar 70



VESA Mounting Range	Minimum Range: 8 in. (200 mm) (W) x 8 in. (200 mm) (H) Maximum Range: 31.5 in. (800 mm) (H) x 23.62 in. (600 mm) (W)
----------------------------	---

Dimensions

Height	36.2 in. (919 mm);
Height with the Crestron Videobar	38.02 in. (966 mm)
Width	31 in. (787 mm)
Depth	4.97 in. (126 mm); 1.25 in. (32 mm) (Extension Bracket Rails)
Depth with the Crestron Videobar	5.95 in. (151 mm)

Weight

10.85 lb (4.92 kg)

Models

UC-SB2-DMK

Display Mounting Kit for Crestron Videobar 70

Available Accessories

For a list of available accessories, visit the [UC-SB2-DMK](#) product page.

The UC-SB2-DMK is an optional display mounting kit for the Crestron Videobar 70. The kit includes two base bracket rails, two extension bracket rails, two tilt brackets and one mounting bracket. These brackets are installed behind a VESA® compliant display device to mount the videobar either on the top or bottom of the display device.

Specifications

Construction

Material	Steel
Mounting	Base Bracket Rails, Extension Bracket Rails, Tilt Bracket, Mounting Bracket

UC-SB2-DMK

Display Mounting Kit for Crestron Videobar 70

The original language version of this document is U.S. English. All other languages are a translation of the original document.

This product may be purchased from select authorized Crestron dealers and distributors. To find a dealer or distributor, please contact the Crestron sales representative for your area. A list of sales representatives is available online at www.crestron.com/How-To-Buy/Find-a-Representative or by calling 855-263-8754.

This product is covered under the Crestron standard limited warranty. Refer to www.crestron.com/warranty for full details.

The specific patents that cover Crestron products are listed online at patents.crestron.com.

Certain Crestron products contain open source software. For specific information, please visit www.crestron.com/opensource.

Crestron, and the Crestron logo are either trademarks or registered trademarks of Crestron Electronics, Inc. in the United States and/or other countries. DisplayPort and VESA are either trademarks or registered trademarks of Video Electronics Standards Association in the United States and/or other countries. Other trademarks, registered trademarks, and trade names may be used in this document to refer to either the entities claiming the marks and names or their products. Crestron disclaims any proprietary interest in the marks and names of others. Crestron is not responsible for errors in typography or photography.

Specifications are subject to change without notice.

©2024 Crestron Electronics, Inc.

Rev 08/06/24

UC-SB2-DMK

Display Mounting Kit for Crestron Videobar 70

UC-SB2-DMK without the
Crestron Videobar

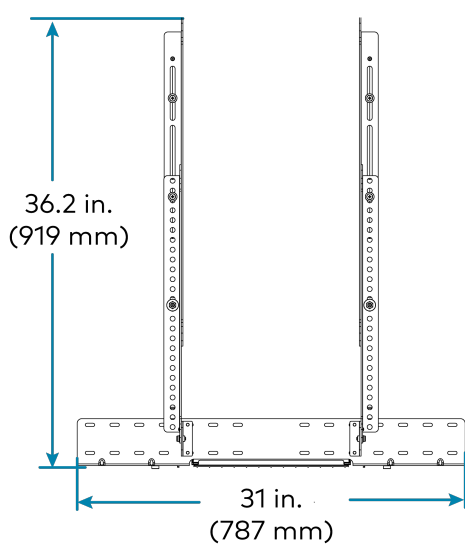

UC-SB2-DMK with
the Crestron Videobar

