



# SMART electric height-adjustable floor stand

Model FSE-520-B



## Overview

Designed for the current line of SMART Board® interactive displays, the SMART electric height-adjustable floor stand features 26" (65 cm) of powered height adjustment with a bounce-back feature if an obstruction is detected. With a sturdy steel frame, the stand supports displays up to 86" (218 cm) diagonal and 254 lb. (115 kg) total weight including accessories. You can easily roll the stand across smooth floors and secure it with the 4" (10 cm) industrial-grade dual locking casters. The stand has a TUV-certified drive system and complies with Americans with Disabilities Act (ADA) standards. The stand also includes multiple VESA mounting points for easy installation of the display and peripherals.

## Hardware

<b>Supported SMART Board displays</b>	<ul style="list-style-type: none"> <li>SMART Board RX series</li> <li>SMART Board GX (V2)</li> <li>SMART Board GX (V3)</li> <li>SMART Board MX (V4)</li> <li>SMART Board MX (V5)</li> <li>SMART Board QX Pro series</li> <li>SMART Board 6000S (V3)</li> </ul>
---------------------------------------	--

<b>Maximum display size</b>	Supports displays up to 86" (218 cm) diagonal and 80" (203 cm) wide
-----------------------------	---

<b>Maximum display weight</b>	220 lb. (100 kg)
-------------------------------	------------------

<b>Maximum lift capacity</b>	254 lb. (115 kg)
------------------------------	------------------

## Height adjustment (with VESA bracket)

<b>Total range</b>	26" (65 cm)
--------------------	-------------

<b>Maximum extended height</b>	81" (206 cm)
--------------------------------	--------------

<b>Minimum extended height</b>	56" (141 cm)
--------------------------------	--------------

## Components

<b>Wheels</b>	4" (10 cm) industrial-grade dual locking casters
---------------	--

<b>Mounting</b>	VESA® mounting patterns	
	400x400	500x400
	600x400	700x400
	800x400	800x600
	All M8.	
	Unit: mm	

<b>Software</b>	SMART Electric Stand Android app available for download.*
-----------------	---

## Power

<b>Supply voltage (North America)</b>	120V AC, 60 Hz
---------------------------------------	----------------

<b>Supply voltage (Europe)</b>	230V AC, 50 Hz
--------------------------------	----------------

<b>Standby mode</b>	< 0.7 W
---------------------	---------

<b>Duty cycle</b>	10% (2 minutes of operation fully loaded, 18 minutes of rest)
-------------------	---

## Operating requirements

<b>Operating temperature</b>	32–104°F (0–40°C)
------------------------------	-------------------

<b>Storage temperature</b>	–4–140°F (–20–60°C)
----------------------------	---------------------

<b>Humidity</b>	90% non-condensing
-----------------	--------------------

## Included cables and accessories

<b>Transfer cable</b>	1
-----------------------	---

<b>Power strip</b>	1
--------------------	---

\*Compatible with SMART displays only.

## SMART electric height-adjustable floor stand

### Certification and compliance

<b>Regulatory certification</b>	FCC, ISED, UL (US and Canada) Usage Area III, CB, CE, LVD, EMC, UKCA
<b>Environmental compliance</b>	RoHS, REACH, POP, Packaging, WEEE, TSCA, CONEG Packaging, California Prop 65
<b>Other</b>	ADA

### Purchasing information

<b>Order number: FSE-520-B</b>	SMART Electric Height-Adjustable Floor Stand, FSE-520-B, UL Listed, Non-Locking, Black
<b>Order number: FSE-500-LS-BK</b>	Laptop Shelf, SMART Stand, FSE-500-LS-BK, Black
<b>Order number: FSE-500-CM-BK</b>	Camera Bracket, SMART Stand, FSE-500-CM-B, Black
<b>Optional accessories</b>	See <a href="http://smarttech.com/accessories">smarttech.com/accessories</a>

### Warranty

<b>SMART Warranty</b>	5 years
-----------------------	---------

## Installation, dimensions, and weights

### Notes

- All dimensions  $\pm 0.3$  cm. All weights  $\pm 0.9$  kg.
- Product ships upright.

### FSE-520-B

#### Dimensions

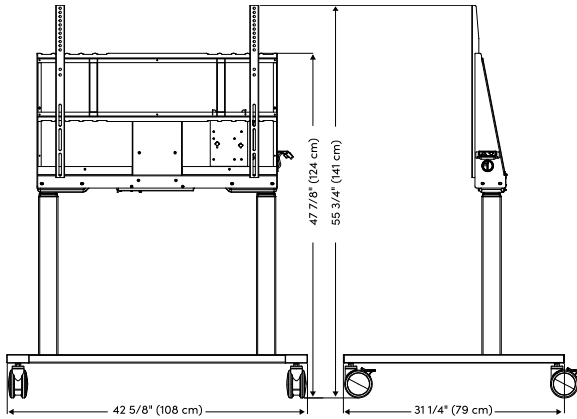

#### Stand Weight

39 kg

#### Shipping carton dimensions

114 cm  $\times$  85 cm  $\times$  18 cm

#### Shipping weight

45 kg

#### Storage cabinet dimensions

75 cm  $\times$  50 cm  $\times$  18.1 cm

### FSE-500-LS-WH

#### Dimensions

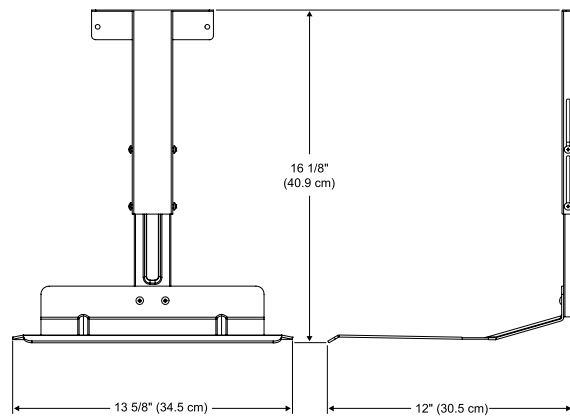

#### Laptop Shelf Weight

2.5 kg

#### Shipping carton dimensions

40 cm  $\times$  34 cm  $\times$  7 cm

#### Shipping weight

3 kg

Installation, dimensions, and weights (continued)

FSE-500-CM-BK

Dimensions

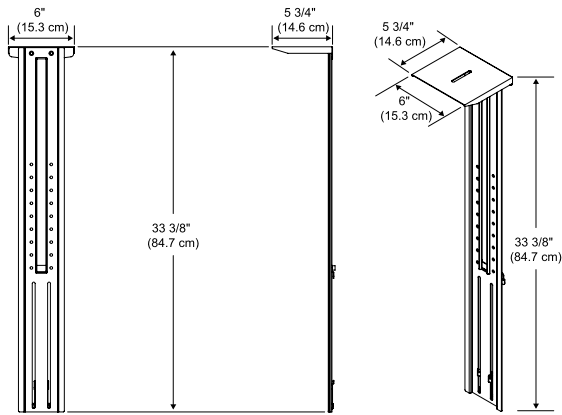

Camera Bracket Weight

1.8 kg

Shipping carton dimensions

88.5 cm × 17 cm × 4 cm

Shipping weight

2 kg

[smarttech.com](http://smarttech.com)  
[smarttech.com/contact](http://smarttech.com/contact)

© 2024 SMART Technologies ULC. All rights reserved. SMART Board, smarttech, the SMART logo and all SMART taglines are trademarks or registered trademarks of SMART Technologies ULC in the U.S. and/or other countries. All third-party product and company names may be trademarks of their respective owners. This product and/or use thereof is covered by one or more of the following U.S. patents: [www.smarttech.com/patents](http://www.smarttech.com/patents). Models and specifications may vary by region. Please contact your local representative for details. Contents are subject to change without notice. December 18, 2024.