

AMRP150H

Projector Ceiling Mount- Heavy Duty

The AMRP150H is a heavy duty ceiling projector mount designed to hold projectors up to a maximum weight of 55 lbs or 25 Kg. The unit has a sleek look with its high quality aluminum and synthetic materials. It supports an in-tube cable management system and a flexible ball joint allowing for different angle placement of a projector.

The AMRP150H features include:

- In Tube Cable Management System
- Patented Ball Joint Structure
- Universal Projector Mount 380mm diameter
- Height Adjustment
- Aluminum Structure



Specifications

Screw Type:	• M3 M4 M5 M6	Material:	• Steel/Aluminum Alloy/Plastic
Weight:	• 1.78Kg / 3.92lbs	Support Max Weight:	• 25Kg / 55lbs
Mounting Pattern:	• Diameter 380mm (15")	Swivel:	• 360°
Dimension (W x H x D):	• 402 x 402 x 577.7mm 15.8" x 15.8" x 22.7"	Vertical Tilt:	• Up to +/-25°
Ceiling to the Display: (Min. to Max.)	• 127.7mm-577.7mm(5.03"-22.74")	Horizontal Tilt:	• Up to +/-25°
		Cable Management:	• Yes

• Warranty and Support

Warranty: 3 Years

Support: Free technical support (phone/email)

AMRP150H

Projector Ceiling Mount- Heavy Duty

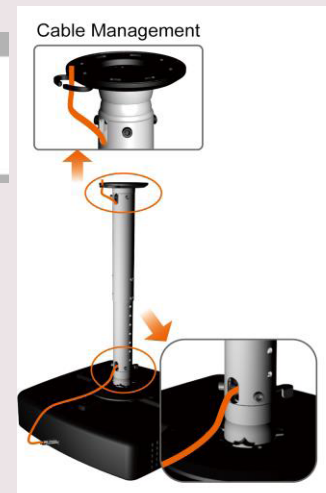
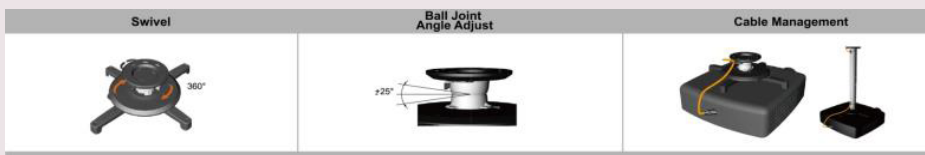
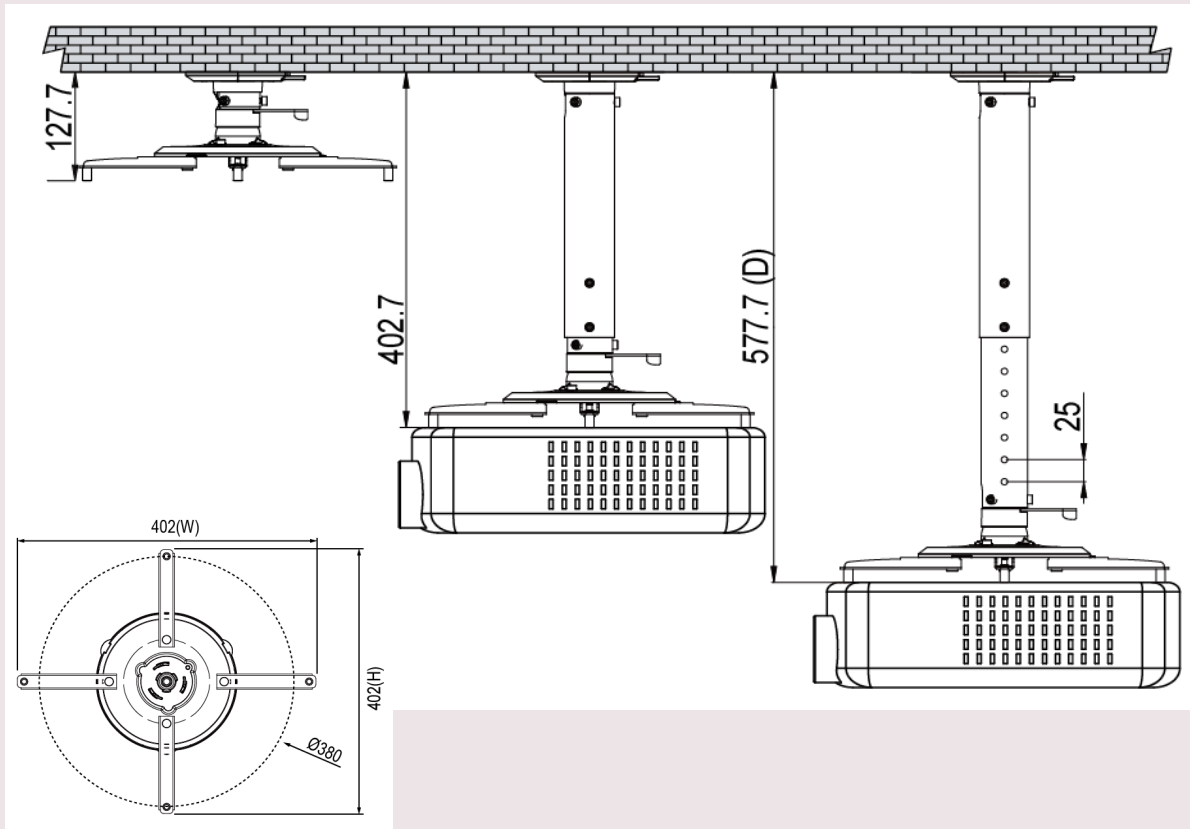

AMRP150H

www.amer.com / www.amermounts.com

sales@amer.com
1-800-262-9703

Specifications subject to change without notice. Errors and omissions excepted. All trademarks are properties of their respective owners.

Revision 1.00