

CyberMed S15

15.6" Fanless Medical Computer



Main Features

- 15.6" LCD Panel
- PCAP Multi-Touch Display
- IP65 Rated
- Global IEC60601-1 Certified
- Fanless Design
- Antimicrobial* Housing



Technical Specifications

Display	15.6" Medical Grade FHD LED Panel 1920x1080, 500 Nits
CPU Support	6th/7th Generation Intel Core i5/i7 Processors
Memory	2x DDR4 2400MHz SO-DIMM sockets, populated up to 32GB
Operating System	Windows 10, Windows IoT, Windows 8.1 (6th Gen only), Windows 7 (6th Gen only), Linux
Video & Graphics	Intel HD Graphics
Touch Screen	PCAP Multi-Touch with Optional Antiglare Technology
Networking	2x Gigabit (Gbe) LAN
Wireless	Intel Dual Band Wireless 802.11 a/b/g/n/ac + Bluetooth 5.1
Expansion Slots	1x mPCIe Half-size slot 1x M.2 E key short slot for PCIe or USB interface
HDD Support	1x 6Gbps Serial ATA III Port
TPM	Version 2.0 Standard. Optional: Version 1.2
Colors	White with Antimicrobial* Germ Protection
Power Supply	120W Medical Grade Power Supply. Input: Universal 100~240V AC, 50-60Hz. Supports Output Range: DC19V. 6.32A Adapters.
Relative Humidity	10%~90% (non-condensing)
Waterproof	IP65 Sealed Front Bezel and IPX1 Back Cover

*Antimicrobial technology protects the housing of the computer & tablet. Cybernet makes no direct or implied claims to protecting users or providing other health benefits.

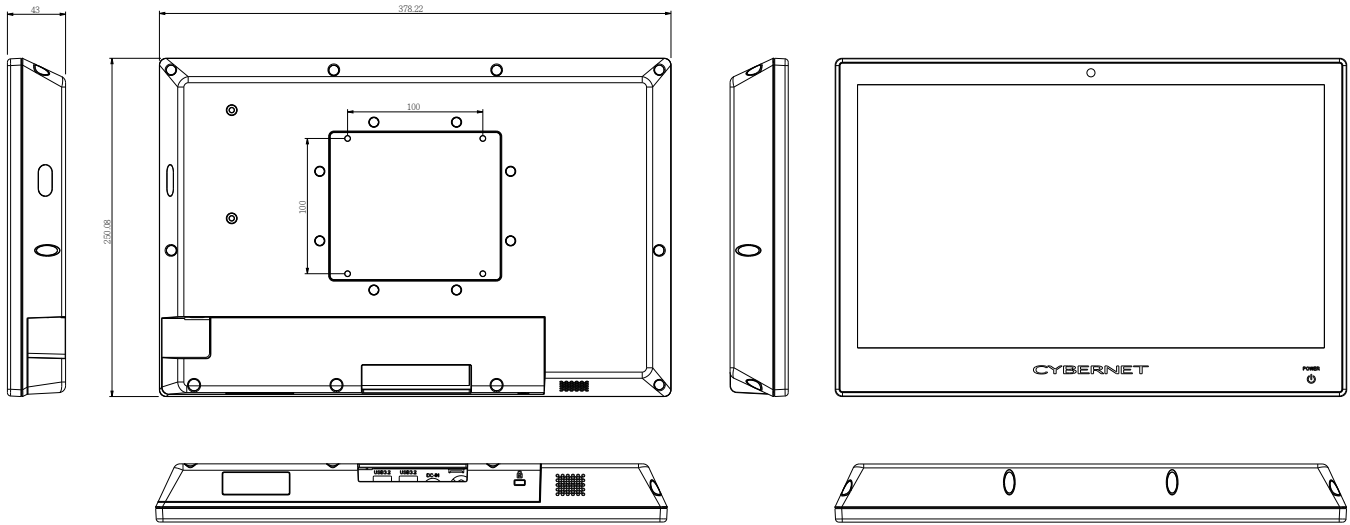

Mechanical & Environmental

Dimensions	14.85" x 9.85" x 1.75" (L,W,D)
Weight	6.6 lbs without base stand
Wall Mount	Supports 75mm & 100mm VESA mounting holes
Environment	Ambient Temperature: 0°C~40°C (operating)
Certifications	UL60601-1, cUL60601-1, IEC60601-1, EN60601-1, UL60950 electrical safety, FCC class B, CE, Energy Star, RoHS, WEEE

Input/Output

I/O Ports	4x USB 3.0 ports 1x RS232/422/485 1x HDMI-In 1x HDMI-Out
Audio	Realtek ALC892 High Definition Audio. One built-in 2.0 watt speakers with two audio jacks for Audio Line Out, and Microphone.

Optional Features

- 5 Megapixel Webcam
- Smart Card Reader
- HIPAA Compliant Privacy Filter
- Internal UPS Battery
- Antimicrobial* Base Stand
- Integrated Imprivata SSO
- Certified RFID Reader
- Extended Warranties

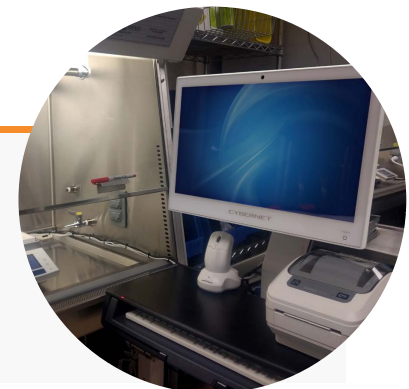

*Antimicrobial technology protects the housing of the computer & tablet. Cybernet makes no direct or implied claims to protecting users or providing other health benefits.

CYBERNET

Find out more at www.cybernet.us
Global Operations: USA · UK · Taiwan · China · Australia
Email: sales@cybernet.us

Ready for your CyberMed S15?

Get Quote