

AMR2S30V

Dual Monitor Stand Vertical Mount Max 32" Monitors

The AMR2S30V is a stand -style monitor stand with an adjustable height that supports up to 2 LCD monitors. The vertical construction of this mount allows for more work space and a great number of advantages for those wanting to create a more ergonomic and functional environment. SEE MORE and DO MORE™ with features like: Hinge Torque Adjustment, Aluminum Alloy Structure, Easy Installation, Cable Management, 360° Pivot Rotation, and Height/ Swivel/Tilt Adjust. In addition to these features, the device is also compatible with VESA 100×100/75X75 and suitable for monitor sizes 24" to 32".



Specifications

Net Weight	• 2.82 Kg(6.2lbs)	Screw Type	• M4
Dimension (W*H*D)	• 493 x 968 x 327 mm (19.41" x 38.11" x 12.87")	Material	• Steel/Aluminum Alloy/Plastic
Hinge Module	<ul style="list-style-type: none"> • Swivel(Hinge): +/-15° • Tilt(Hinge): +/-15° • Pivot: 360° • User Torque Adjust: Available 	Display Support	<ul style="list-style-type: none"> • Mounting Pattern: 100x100/75x75 mm • Display Type: Dual Monitor • Panel Size Support: <=32" • Support Max.Weight (Per Hinge): 8Kg(17.6lbs)
Height Adjust	• Height Adjustment Range(Max.): 910 mm(35.83")	Cable Management	• Yes

Warranty and Support

Warranty: 3 Years
 Support: Free technical support (phone/email)

AMR2S30V

Dual Monitor Stand Vertical Mount Max 32" Monitors

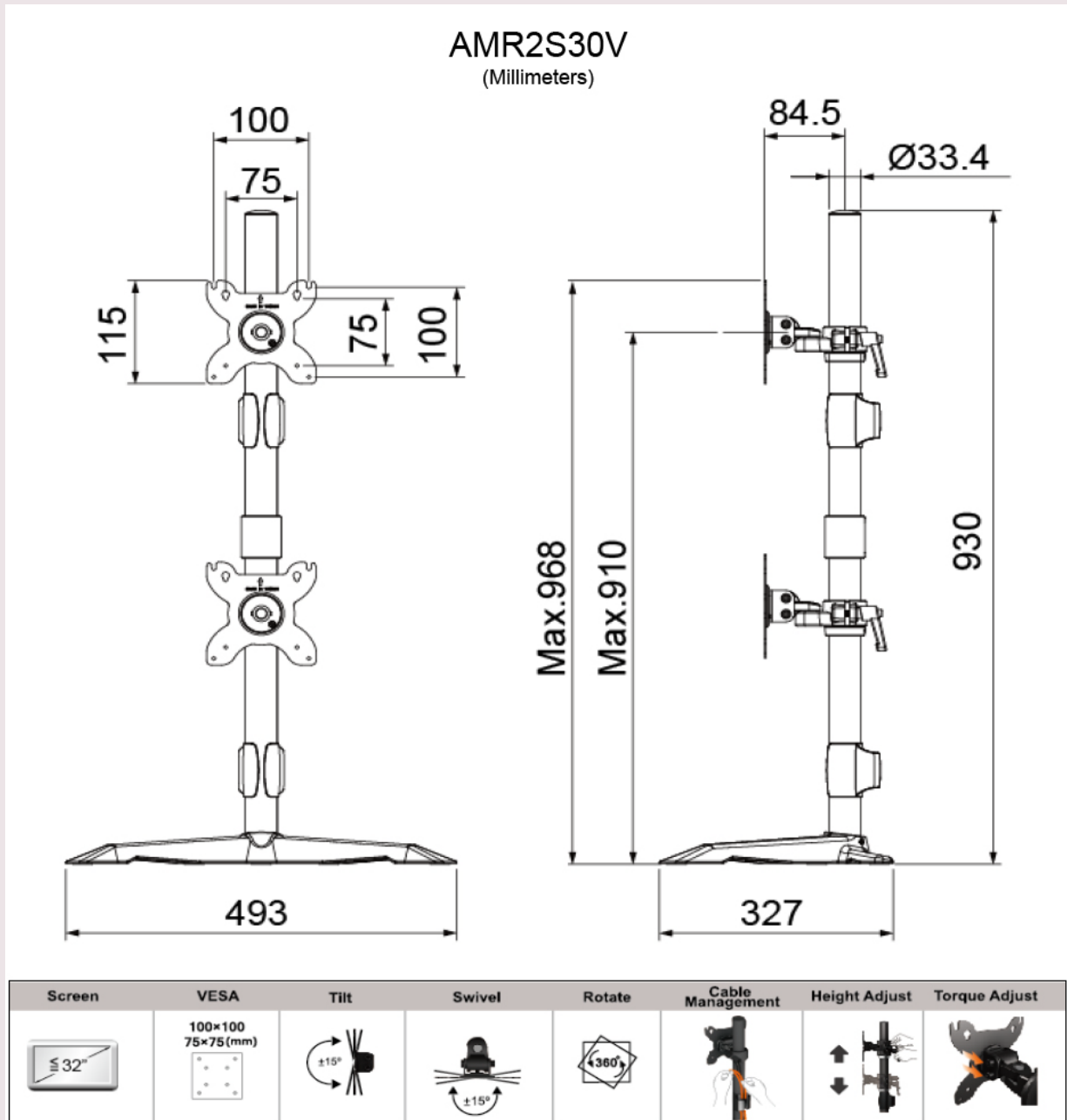

www.amer.com / www.amermounts.com

sales@amer.com

1-800-262-9703

Specifications subject to change without notice. Errors and omissions excepted. All trademarks are properties of their respective owners.

Revision 1.02