

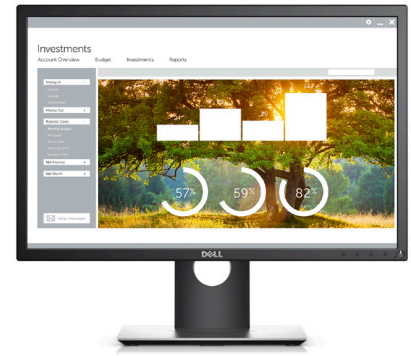

## Dell 22 Monitor P2217



The smart choice to help boost productivity with more comfort and convenience.

### Enhanced productivity

Help boost your productivity with this 22" 16:10 aspect ratio monitor.

- Enjoy a better visual experience with a slim border design — great for multi-monitor setups.
- Efficiently auto apply predefined colour settings for various applications via Dell Auto Mode.
- Reduce desk clutter with integrated power and cable management.

### Improved comfort

Work the way you like, comfortably.

- Adjust your view with flexible adjustability features including tilt, pivot, swivel and height-adjustable stand.
- See images clearly with consistent colours across an ultrawide viewing angle.
- Optimise eye comfort with a flicker-free screen and ComfortView feature<sup>6</sup> which minimises blue light emission.
- Enjoy added convenience and usability thanks to two easily accessible USB 3.0 ports located on the side of the monitor.

### Smart investment

You're ready now and for the future with this smart choice.

- Future proof your connectivity with a wide range of digital ports.
- Choose an eco-conscious design which meets latest regulatory and environmental standards.
- Get a variety of mounting options and accessories to flexibly configure your office.

### Reliable

Comes with Dell's high reliability promise.

- Enjoy great reliability from the #1 monitor brand worldwide.\*
- Experience peace of mind from Dell's commitment to quality and customer satisfaction with the Premium Panel<sup>5</sup> Guarantee.
- Minimise down time with Dell's standard 3-Year Advanced Exchange Service<sup>3</sup>.
- Upgrade to 24x7 phone support and Advanced Exchange Service with optional Dell ProSupport<sup>7</sup>.



For more information visit  
[www.dell.com/monitors](http://www.dell.com/monitors)

Thank you  
for making  
Dell Monitors

**#1**  
worldwide\*

Easily adjust the panel to your preferred viewing position.

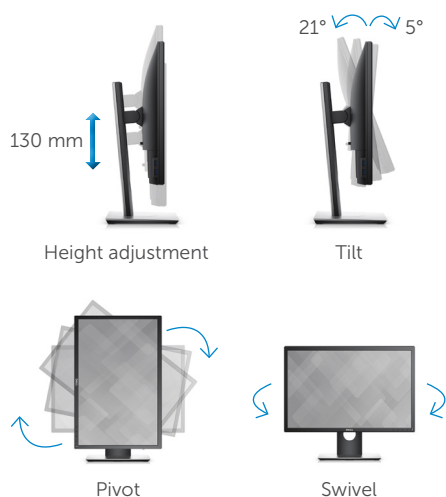

### Connectors



- A Power cable connector
- B HDMI
- C DisplayPort
- D VGA
- E USB upstream
- F USB downstream
- G Stand lock feature



### What's in the box?

#### Components

- Monitor panel
- Stand (riser and base)

#### Cables

- Power cable (varies by country)
- VGA, DisplayPort, USB 3.0 upstream cables

#### Documentation

- Drivers and documentation media (CD)
- Quick Setup Guide
- Safety and regulatory information

## Dell 22 Monitor | P2217

### Display

Model number	P2217
Viewable image size (diagonal)	55.9 cm (22 inches)
Active display area	
Horizontal	473.76 mm (18.65 inches)
Vertical	296.10 mm (11.66 inches)
Maximum resolution	1680 x 1050 at 60 Hz
Aspect ratio	16:10
Pixel pitch	0.282 mm x 0.282 mm
Brightness (typical)	250 cd/m <sup>2</sup>
Colour gamut (typical)	84% <sup>1</sup>
Colour depth	16.7 million colours
Contrast ratio (typical)	1000:1
Mega dynamic contrast ratio	4 million:1
Viewing angle (typical) (vertical/horizontal)	160°/170°
Response time (typical)	5 ms black-to-white (typical)
Panel technology	TN
Backlight	LED
Bezel colour	Black

### Connectivity

Connectors	DisplayPort 1.2, HDMI 1.4, VGA, 2 x USB 3.0 (side), 2 x USB 2.0 (bottom)
------------	--

### Features

Stand	Tilt (Typical: 5° forward or 21° backward), pivot (90°), swivel (45°), height adjustable (130 mm)
Security	Security lock slot (security lock not included)
VESA mounting support (wall mount kit sold separately)	Dell Quick Release feature (100 x 100 mm)
Other	ComfortView

### Power

AC input voltage/frequency/current (typical)	100 to 240 VAC / 50 or 60 Hz ± 3 Hz / 1.5 A (typical)
Power consumption (normal operation)	18 W (typical, without USB load) 45 W (Max.)
Power consumption (active-off mode)	< 0.3 W

### Dimensions (with stand)

Height (compressed ~ extended)	367.4 mm ~ 497.4 mm (14.46 inches ~ 19.58 inches)
Width	503.4 mm (19.82 inches)
Depth	180.0 mm (7.09 inches)

### Weight

Weight (panel only – no stand)	3.00 kg (6.61 lb)
Weight (with stand)	5.33 kg (11.75 lb)
Shipping weight	7.03 kg (15.49 lb)

### Standard service plan

- 3 years Premium Panel Guarantee<sup>5</sup>
- 3 years Advanced Exchange Service<sup>3</sup> and Limited Hardware Warranty<sup>4</sup>

### Optional service upgrade

- Dell ProSupport<sup>7</sup>

### Environmental compliance

ENERGY STAR<sup>®</sup>, EPEAT<sup>®</sup> Gold<sup>2</sup>, TCO Certified Displays, CEL, CECP, RoHS, WEEE, ErP (EuP) Standards, Korea E-Standby

\*Dell monitors are #1 worldwide for 3 consecutive years! Source: IHS Global Inc. Desktop Monitor Market Tracker (2013 to 2015) ID# G16000073

\*\*Registered in US and Canada only.

<sup>1</sup> Colour gamut (typical) is based on CIE1976 (84%) and CIE1931 (72%) test standards.

<sup>2</sup> EPEAT Gold registered in the U.S. EPEAT registration varies by country. See [www.epeat.net](http://www.epeat.net) for registration status by country.

<sup>3</sup> Advanced Exchange Service: Replacement part/unit dispatched, if needed, following completion of phone/online diagnosis. Fee charged for failure to return defective unit. Availability varies. Other conditions apply.

<sup>4</sup> For a copy of the Limited Hardware Warranty, write Dell Products, Dell House, The Boulevard, Cain Road, Bracknell, Berkshire, RG12 1LF, UK or see [dell.com/warranty](http://dell.com/warranty).

<sup>5</sup> In the event you discover even one bright pixel during the Limited Hardware Warranty period, a free panel exchange is guaranteed. (see pixel panel info located on Dell.com web page for complete details): <http://support.dell.com/support/topics/global.aspx/support/kcs/document?docid=414288>

<sup>6</sup> ComfortView feature reduces blue light emission and brightness onscreen.

<sup>7</sup> Includes 24x7 in-region phone support and replacement monitor shipped to you the next business day.

