

# AMR2S30

Dual monitor stand for up to 32" displays

The sturdy construction of this 2-display panel mount support offers a great number of advantages for those wanting to create a more ergonomic and functional workspace. SEE MORE and DO MORE™ with features like: 360° Pivot Rotation, Height Adjustment, Cable Management, Monitor Angle Adjustment, Aluminum Alloy Structure, Easy Installation, and VESA Mounting. Our LCD/LED monitor stand is an advanced display system providing increased efficiency and productivity through the use of our Torque Adjust Hinge System, which allows for display rotation, swivel and tilt functions. In addition to these features, the device is also compatible with VESA 100x100/75x75 and suitable for monitor sizes 24" to 32".



## Specifications

Net Weight	• 3.71 Kg(8.16lbs)	Screw Type	• M4
Dimension (W*H*D)	• 961 x 504 x 327 mm (37.83" x 19.84" x 12.87")	Material	• Steel/Aluminum Alloy/Plastic
Hinge Module	<ul style="list-style-type: none"> <li>• Swivel(Hinge): +/-15°</li> <li>• Tilt(Hinge): +/-15°</li> <li>• Pivot: 360°</li> <li>• User Torque Adjust: Available</li> </ul>	Display Support	<ul style="list-style-type: none"> <li>• Mounting Pattern: 100x100/75x75 mm</li> <li>• Display Type: Dual Monitor</li> <li>• Panel Size Support: ≤32"</li> <li>• Support Max.Weight (Per Hinge): 10Kg(22.1lbs)</li> </ul>
Height Adjust	• Height Adjustment Range(Max.): 444 mm(17.48")	Cable Management	• Yes

### Warranty and Support







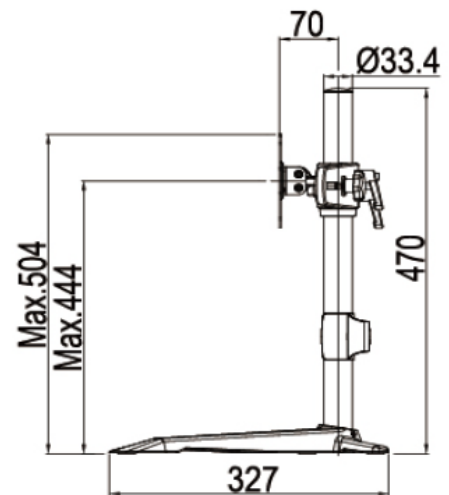
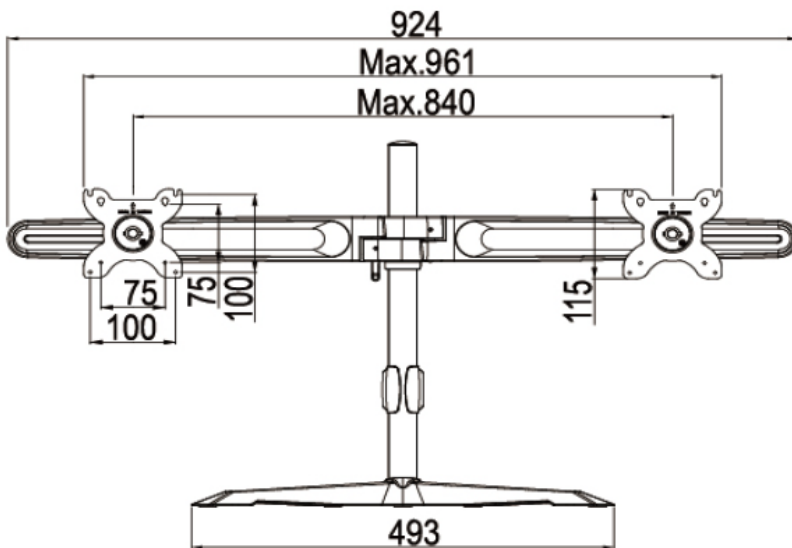

Warranty: 3 Years  
 Support: Free technical support (phone/email)

# AMR2S30

Dual monitor stand for up to 32" displays

AMR2S30  
(Millimeters)

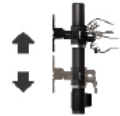

Screen	VESA	Tilt	Swivel	Rotate	Cable Management	Height Adjust	Torque Adjust
							

[www.amer.com](http://www.amer.com) / [www.amermounts.com](http://www.amermounts.com)

sales@amer.com  
1-800-262-9703

Specifications subject to change without notice. Errors and omissions excepted. All trademarks are properties of their respective owners.

Revision 1.02