



Lexmark MS911de

High-volume output, long-life components, solid security and advanced finishing make the Lexmark MS911de the ultimate SRA3 monochrome printer from Lexmark.



Up to 55 ppm



Solutions



10.9 cm (4.3-inch) touch screen



SRA3



Security



Finishing function

Advanced features and output-size options

The Lexmark MS911de SRA3 monochrome printer brings speed, connectivity, security, sustainable design, user-centric interface and advanced finishing to your enterprise—supported by the complete Lexmark user experience, service options and solutions library.

Top performance, less downtime

Speedy printing: The MS911de takes only seconds to produce a first page, then prints up to 55 pages per minute. The fast printing mechanism is backed by a powerful 800 MHz dual-core processor and up to 2.5 gigabytes of memory to ensure swift output and satisfied users.

Top-end input: The printer starts with a thousand pages of input capacity between two standard 500-sheet trays, and space for an additional 150 sheets in the multipurpose feeder. With additional trays and feeders, the line tops out at a massive 6,650 pages of input capacity. The trays even include indicator LEDs to show at a glance when paper's running low or completely out.

High-volume output: Meet demanding output requirements for both standard and SRA3 print jobs with the MS911de's 300,000-page maximum monthly duty cycle.

Long-life components: The photoconductor unit is rated for up to 125,000 pages, while the fuser can reach up to 720,000 pages. Replacing fewer components over the life of the product not only saves resources, but means less maintenance and more uninterrupted productivity.

Connected and capable

Connectivity: Gigabit Ethernet instantly connects the MS911de to standard networks, while multiple USB 2.0 and optional parallel ports link to individual device outputs. Optional wireless (802.11n) connectivity supports flexible printer placement on wireless networks.

Protocols: The MS911de supports nearly all printing protocols, assuring seamless output from any device or application with printing capabilities.

Mobile printing: It's a big device that sits in one place. Your users don't, and with Lexmark Mobile Print they can print from anywhere via mobile devices*, as well as traditional desktop computers.

*For more information on Lexmark Mobile Solutions see lexmark.com/mobile



Comprehensive security

Print release: An optional card reader lets the MS911de printer confirm the identity of a user before releasing a print job they've sent—or offers them a choice of documents printed on demand.

Remote manageability: Control device settings from any browser (when network-connected), including security settings, device defaults, consumable alerts and more.

Network security: A comprehensive set of enterprise-class network security features and protocols are built in to protect your device, your information and your network—including SNMPv3 and IPSEC.

Secure storage: The optional encrypted hard disk features advanced functions like automatic disk wiping and manual “out of service” disk wiping to ensure confidential information doesn't end up in the wrong place.

Sustainable design

Energy-saving sleep modes: When not in use, the MS911de goes into a sleep mode that takes less than four watts of power—as little as a traditional night light.

Duplexing: Integrated two-sided printing, a user-selectable option, saves paper and doesn't slow you down, printing individual sheet sides (images) at up to the printer's rated output speed.

Certifications: EPEAT Silver and 2014+ Energy Star certifications confirm the printer's energy efficiency.

Portal to productivity

The MS911de's tilting, 10.9 cm (4.3-inch) colour touch screen keeps users informed of device status and error messages, while visually guiding them through tasks like clearing paper jams.

The vivid display has magnification and reverse image options to assist users with varying abilities.

And Lexmark's innovative e-Task user interface makes it easy to take advantage of pre-installed solutions like:

Forms and Favourites: Instantly access required online forms from any eTask Lexmark printer or multifunction product (MFP) to help simplify and streamline work processes.

Eco-Settings: Choose from multiple print settings to help reduce energy, paper and toner consumption. Utilising these settings can help reduce the environmental impact of your printer.

Background and Idle Screen: Change the background of the touch screen on your Lexmark printer, similar to setting your computer's desktop wallpaper. Whether it's your business or corporate logo, or images to educate others about specific initiatives or offerings, the Background and Idle Screen solution makes it easy to upload an image and change it as often as you like.



Additional available solutions include:

Lexmark Print Management: Improve the efficiency of your output environment by helping to reduce unnecessary printing and gain valuable insight into how your output infrastructure is utilised.

Lexmark Smart Card Authentication: A comprehensive collection of apps enables secure smart card authentication on Lexmark printing and imaging devices.

Advanced finishing options

Simple finishing: Optional staple finisher has the ability to singleposition-staple up to 50 sheets or offset stack the print job without increasing the footprint of the printer.

Staple and hole punch finishing: Optional floor-standing finishers offset stack, multi-position-staple and hole-punch in popular configurations. The floor-standing finishers can staple or holepunch at up to the printer's maximum rated print speed for complete efficiency.

Booklet finishing: Automated folding functionality in optional finisher lets you create tri-fold documents or booklet-style ones with saddle-stitched binding, plus all the options of the staple and hole punch finisher.

The Lexmark user experience

Your users will appreciate the consistent user interface of Lexmark devices. And every Lexmark device is right at home as part of Lexmark managed print services (MPS), as well as the worldwide Lexmark service network that backs up the MS911de for maximum uptime and fewer service worries.

MS911de Series printer features

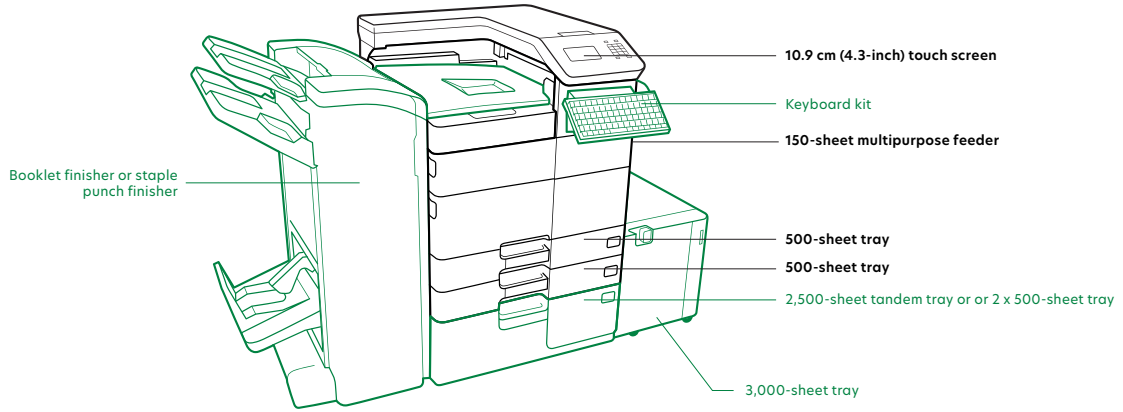

Product specifications	Lexmark MS911de
Print	
Display	Lexmark e-Task 10.9 cm colour touch screen
Print Speed: Up to ⁵	Black: 55 ppm
Time to First Page: As fast as	Black: < 5.5 seconds
Print Resolution	Black: 1200 Image Quality, 1200 x 1200 dpi, 2400 Image Quality, 600 x 600 dpi
Memory / Processor	Standard: 512 MB / Maximum: 2560 MB / Dual Core, 800 MHz
Hard Disk	Option available
Recommended Monthly Page Volume ²	15,000 - 59,000 pages
Maximum Monthly Duty Cycle: Up to ³	300,000 pages per month
Supplies	
Laser Cartridge Yields (up to) ¹	32,500-page High Yield Cartridge
Photoconductor Estimated Yield: Up to ⁴	125,000 pages, based on 3 average letter/A4-size pages per print job and ~ 5% coverage
Cartridge(s) Shipping with Product ¹	21,000-page Starter Toner Cartridge
Paper Handling	
Included Paper Handling	250-Sheet Output Bin, 150-Sheet Multipurpose Feeder, 2 x 500-Sheet Input
Optional Paper Handling	Staple Punch Finisher, Inline Stapler, 2500-Sheet Tandem Tray, 3000-Sheet Tray, Booklet Finisher, 2 x 500-Sheet Tray
Paper Input Capacity: Up to	Standard: 1150 pages 75 gsm bond / Maximum: 6650 pages 75 gsm bond
Paper Output Capacity: Up to	Standard: 250 pages 75 gsm bond / Maximum: 3500 pages 75 gsm bond
Media Types Supported	Card Stock, Envelopes, Labels, Plain Paper, Transparencies, Refer to the Card Stock & Label Guide.
Media Sizes Supported	10 Envelope, 7 3/4 Envelope, 9 Envelope, A3, A4, A5, B5 Envelope, C5 Envelope, DL Envelope, Executive, Folio, JIS-B4, JIS-B5, Ledger, Legal, Letter, Statement, Universal, Super Tabloid (305 x 457 mm), Oficio, A6, SRA3
General Information	
Standard Ports	One Internal Card Slot, USB 2.0 Specification Hi-Speed Certified (Type B), Gigabit Ethernet (10/100/1000), Front USB 2.0 Specification Hi-Speed Certified port (Type A), Two Rear USB 2.0 Specification Hi-Speed Certified ports (Type A)
Optional Network Ports / Optional Local Ports	Internal MarkNet N8350 802.11b/g/n Wireless / Internal RS-232C serial, Internal 1284-B Bidirectional Parallel
Noise Level: Operating	Print: 54 dBA
Specified Operating Environment	Altitude: 0 - 2500 metres, Humidity: 15 to 85% Relative Humidity, Temperature: 10 to 30°C
Product Warranty	1-Year Base Warranty Service
Size (mm - H x W x D) / Weight	770 x 615 x 697 mm / 74 kg

¹Average standard page yield value declared in accordance with ISO/IEC 19752. ²Recommended Monthly Page Volume² is a range of pages that helps customers evaluate Lexmark's product offerings based on the average number of pages customers plan to print on the device each month. Lexmark recommends that the number of pages per month be within the stated range for optimum device performance, based on factors including: supplies replacement intervals, paper loading intervals, speed, and typical customer usage. ³Maximum Monthly Duty Cycle³ is defined as the maximum number of pages a device could deliver in a month using a multishift operation. This metric provides a comparison of robustness in relation to other Lexmark printers and MFPs. ⁴Actual Yield may vary based on other factors such as device speed, paper size and feed orientation, toner coverage, tray source, percentage of black-only printing and average print job complexity. ⁵Print and copy speeds measured in accordance with ISO/IEC 24734 and ISO/IEC 24735 respectively (ESAT). For more information see: www.lexmark.com/ISOspeeds.

This is a Class A device according to the FCC Rules and international electromagnetic emissions standards. This device is not intended for use in residential or domestic environments due to potential interference to radio communications.

© 2016 Lexmark and the Lexmark logo are trademarks of Lexmark International, Inc., registered in the United States and/or other countries. All other trademarks are the property of their respective owners. ENERGY STAR® is a U.S. registered mark.

AirPrint and the AirPrint logo are trademarks of Apple Inc.