



FIXED HEIGHT MOBILE STAND

FPS1XL/FH/GG

Take control of creative, presentation and collaboration work spaces. Salamander's beautiful and highly functional FPS Series Mobile Stands offer superior ergonomics complimenting any touch display with improved productivity, unrivaled flexibility and lifetime value.

A stylish, sleek and compact design moves easily between spaces. A thoughtful range of accessories provides even more utility and an improved user experience.

- Mobile stand for interactive display / touchscreen panel
- Supports most VESA compliant display up to 400 lb (181 kg) including Microsoft 84" Surface Hub
- Ergonomic design. Adjustable height positioning (during set-up) provides best possible ergonomics and viewing
- ADA compliant design
- Superior mobility. High quality commercial grade locking casters and integrated handles provide easy maneuverability and transport
- Fully concealed cable management allows clean, secure and uncluttered installation
- Range of travel, Center of screen : Min- 47.37" (1203 mm) and Max 57.87" (1470 mm)
- Internal storage for rack mounted electronic components (2RU), peripherals and accessories
- Durable construction. Made in USA of powder coated steel
- Options available for peripheral equipment mounting, retractable cable reel, keyboard tray and more
- Limited Lifetime Warranty



ADA Compliant





FIXED HEIGHT MOBILE STAND

FPS1XL/FH/GG

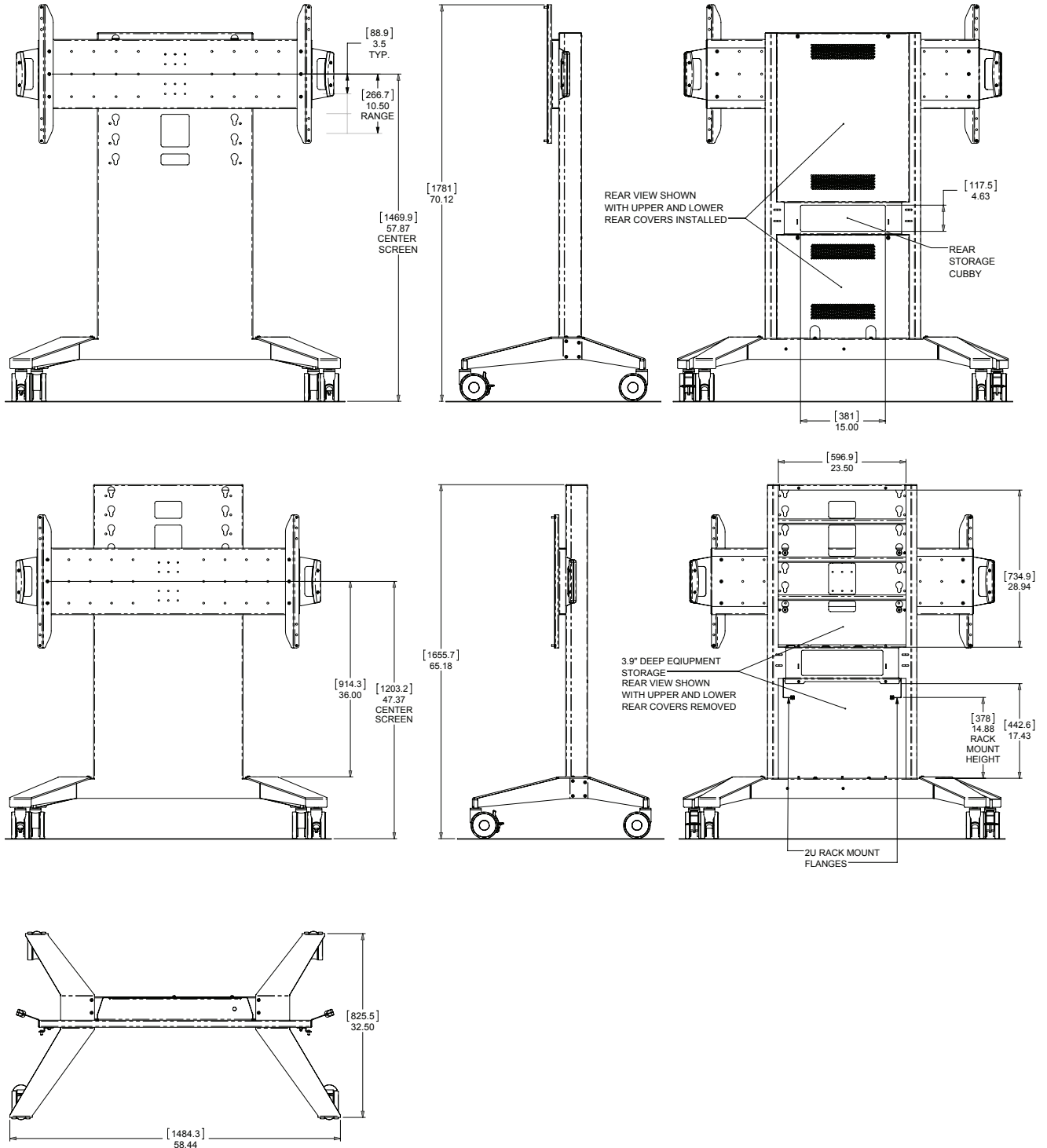



FIXED HEIGHT MOBILE STAND

FPS1XL/FH/GG

PRODUCT SPECIFICATIONS	Metric (mm)	US/Imperial Inches	SHIPPING DIMENSIONS	
Length	1484	58.44	1,575 mm	62 inch
Overall Height Range	1656 - 1781	65.18 - 70.12	927 mm	36.5 inch
Center of Screen Range of Travel	1203 - 1470	47.37 - 57.87		
Depth	695.4	27.38	330 mm	13 inch
Weight	91 kg	200 lbs	91 kg	200 lbs
Max Load Capacity	181 kg	400 lbs		
UPC Number		634878400152		

VESA COMPLIANT MOUNT PATTERN

Horizontal - 400, 600, 800, 1000, 1200mm

Vertical - 400, 500, 600mm

DISPLAY MOUNTING

M8

CASTER WHEELS

5" (125mm) HD, non marking, brakes on two





FIXED HEIGHT MOBILE STAND

FPS1XL/FH/GG

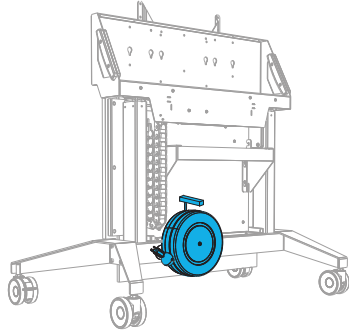

Cable Reel 30' Payout, 24"
Tri-Tap Female End
FPSA/CR

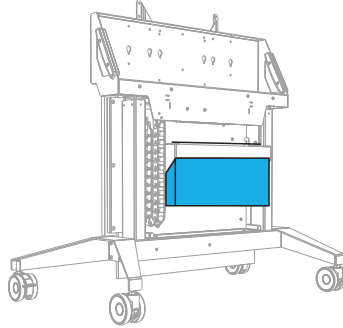

Power Distribution Unit
SA/RM/PDU

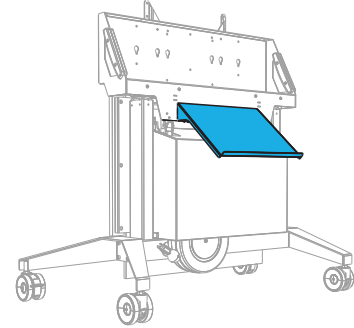

Keyboard Storage Shelf- Graphite
FPSA/KS/GT

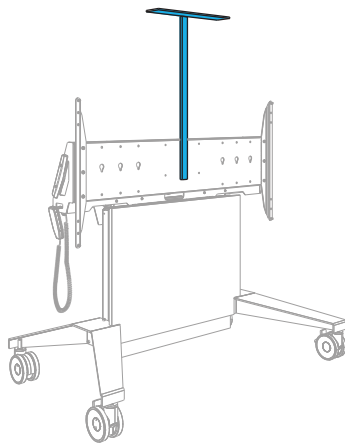

Camera Mount Shelf
FPSA/CS

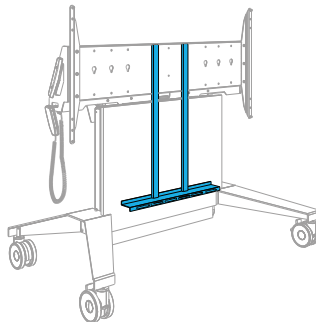

Speaker Bracket Kit
FPSA/SBK