

1224RF • 24" Refrigerator/Freezer • Combo® Models

FEATURES & BENEFITS



STAINLESS SOLID



INTEGRATED SOLID



BLACK SOLID



WHITE SOLID

PERFORMANCE	<ul style="list-style-type: none"> • Refrigerator volume of 4.2 cu ft holds up to 61 bottles (12 oz) or 114 cans (12 oz) • Freezer volume of 1.5 cu ft • Digital Touch Pad Control is conveniently located on upper face of unit • Refrigerator temperature range: 34°F - 45°F • Frost Free Freezer maintains a temperature range of 0°F - 5°F • Digital passive cooling system • Maintains temperature to within 1°F of the set point to maximize preservation
INTERIOR/EXTERIOR	<ul style="list-style-type: none"> • White interior is illuminated with LED lighting • Three removable tempered glass shelves • Standard commercial stainless steel handle is interchangeable with professional handle accessory • Door swing is field reversible
INTEGRATION	<ul style="list-style-type: none"> • Unit is designed to be built-in or can be freestanding with the freestanding accessory kit • Integrated model requires 3/4" custom door panel (panels not supplied by U-Line) • Four independently adjustable leveling legs provide a precise undercounter fit • Available in the following finishes: Stainless, Integrated, Black, or White

MODEL DETAILS

Model	Voltage/Hz	Door Swing	Finish	Shipping Weight
U-1224RFS-00A	115 / 60	Field Reversible	Stainless Solid	123 lbs
U-1224RFINT-00A	115 / 60	Field Reversible	Integrated Solid	120 lbs
U-1224RFB-00A	115 / 60	Field Reversible	Black Solid	123 lbs
U-1224RFW-00A	115 / 60	Field Reversible	White Solid	123 lbs

ACCESSORIES

Model	Description	Finish	Shipping Weight
23074	Professional Door Handle, 1 1/4" Diameter	Stainless	2 lbs
23073	Commercial Door Handle, 7/8" Diameter	Stainless	2 lbs
U-FSK-B	Freestanding Kit	Black	3 lbs

Combo® Models • 24" Refrigerator/Freezer • 1224RF

DIMENSIONS

Dimensions shown apply to all finishes, including Integrated (INT) models with 3/4" integrated panel/frame installed.

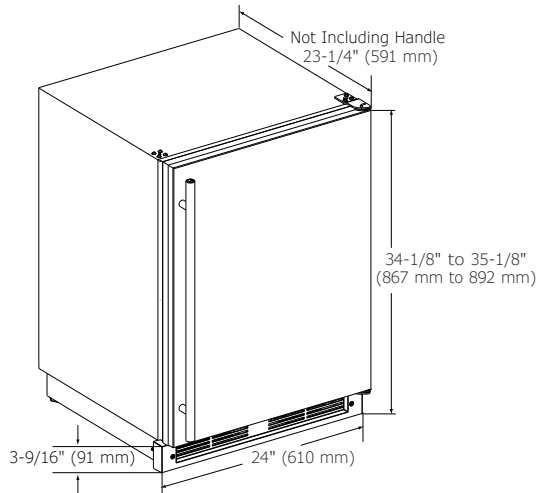

CABINET CUT-OUT

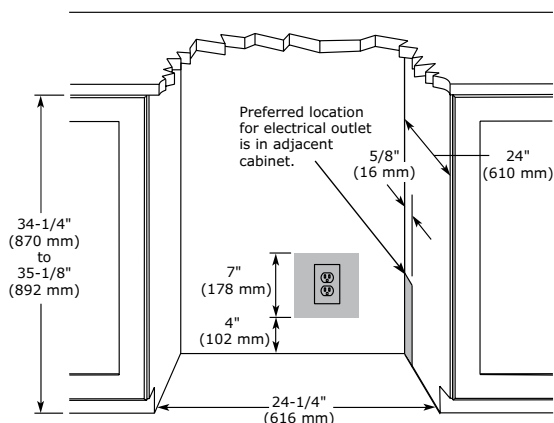

INSTALLATION NOTES

- When installing adjacent to wall, ensure 2 1/2" clearance on hinged side for 90° door opening, allowing ample room for door handle.
- Cutout includes the additional 1/4" width overall to ensure proper installation.
- No additional clearance around sides, top or rear of unit is needed for ventilation.
- Do not obstruct front grille air flow.

SPECIFICATIONS

Model	1224RF
Amps: Running	2.4
Capacity: Bottle (12 oz)	61
Capacity: Can (12 oz)	114
Capacity: Volume (cu ft)	Ref: 4.2 Fzr: 1.5
Control Type	Digital Touch Pad
Defrost Type	Frost Free
Dimensions: Product Depth	23 1/4" / 591 mm
Dimensions: Product Height	34 1/8" / 867 mm
Dimensions: Product Width	24" / 610 mm
Energy Consumption: Avg. Per Year	496 kWh
ENERGY STAR	No
Panel Height	30 1/4" / 768 mm
Panel Thickness	3/4" / 20 mm
Panel Type	Solid Panel
Panel Width	23 3/4" / 603 mm
Product Weight: Max	113 lbs
Refrigerant Type	R134a
Sabbath (Star K Certified)	Yes
Temperature Range	Ref: 34°F - 45°F Freezer: 0°F - 5°F

ELECTRICAL REQUIREMENTS

This unit requires a grounded a polarized 115 VAC, 60 Hz, 15 A power supply (normal household current).



Please visit u-line.com to view this model's User Guide. All specifications are subject to change without notice.