

WS6222

Amer Acuity™ Wireless Controller with 128AP License max 1024AP Support

The WS6222 wireless access controller (AC) is part of the Amer Acuity™ line of Enterprise class manageable wireless solution. The WS6222 is designed to support up to 2 SFP+ 10 Gigabit Ethernet ports 12 10/100/1000Base-T ports and 8 Gigabit SFP ports. The unit is shipped with a default license for 128 Amer Acuity™ access points with expansion possible to a maximum of 1024 AP. Multiple controller units may also be clustered to support a maximum of 64 controllers.

The WS6222 is ASIC engineered to support line rate forwarding of IPv4/IPv6 Layer 2 (L2) and Layer 3 (L3) data packets. In addition to full IPv6 compatibility this device supports a broad range of static routing protocols including RIP, OSPF, BGP and PIM, as well as dynamic routing protocols such as IPv6 RIPng, OSPFv3 and PIM6.

The WS6222 employs an intelligent temperature control and heat dissipation system adding to its reliability and resiliency ensuring efficient operation even during heavy load conditions.

With advanced management features like precise user management control, RF management, advanced security features, QoS, seamless roaming and authentication coupled with the chip-level forwarding capabilities the WS6222 is an effective and performance rich controller ideal for an array of WLAN applications.

Highlights

High-Performance and High-Reliability

► High-density access ports and smart wired/wireless control

The WS6222 employs an ASIC-based wireless forwarding technology to provide the highest port density and highest wireless throughput when compared with similar wireless access controllers in the industry. With support of both wireless and wired switching, all wireless and wired traffic are uniformly forwarded in the same chip. With its wired/wireless integrated control and forwarding architecture, the WS6222 combines the functions of both a wireless controller and a routing switch improving network performance and management.



► Flexible data forwarding

The WS6222 may be simply deployed on an existing Layer 2 (L2) or Layer 3 (L3) network without changes to the existing architecture. The Data forwarding mode of the Access Points can be configured by the Wireless Access Controller to have all data forwarded through the Controller or directly to a wired network for local switching based on the service set ID (SSID) and the virtual local area network (VLAN) configuration on the network. The benefit of this local forwarding technology is the ability to enable delay-sensitive data with high real-time transmission requirements to be forwarded without added processing delay. This allows the wireless network to better handle high bandwidth applications such as high-definition Video on Demand (VoD) and Voice over WLAN (VoWLAN).

► Redundancy

The WS6222 supports the following redundancy configurations:

- 1+1 fast backup
- N+1 backup
- N+N backup
- Portal 1+1 backup
- DHCP server hot backup

WS6222

Amer Acuity™ Wireless Controller with 128AP License max 1024AP Support

► AC and DC input power

The WS6222 supports both AC and DC input power, facilitating different deployment requirements. Power redundancy is also supported with the connection of both an AC and a DC source.

► End-to-end QoS

The WS6222 provides ASIC-based QoS and comprehensively supports Diff-Serv, such as flow classification, traffic policing, queue management, and queue scheduling. QoS is supported based on per-terminal control and air interface control. The entire wireless network provides an end-to-end QoS environment, creating an integrated network that simultaneously bears voice, data, and video services.

► Automatic AP emergency mechanism

In a centralized network architecture network down time could occur when a wireless controller goes offline. The Amer Acuity™ family support an automatic emergency mechanism. This mechanism allows the APs to intelligently detect if it has communication with the centralized controller. When detecting that the wireless Controller is off-line, the AP quickly switches its operating mode so that it may continue to forward data while enabling new users to access the network. This mechanism attains high availability in the entire wireless network and maintains high uptime for the wireless network.

► Dual-OS backup mechanism

The WS6222 supports a dual-OS backup mechanism. When the WS6222 fails to start from the active OS, it can immediately start from a standby OS, thereby improving the uptime of the controller.

Intelligent Control and Automatic Perception

► Intelligent RF management

The WS6222 provides an automatic power and channel adjustment function which employs RF detection and management algorithms to achieve better RF coverage. When there are large amounts of radio interference to an Access Point, the controller can avoid this interference by switching the operating channel of the AP. Another feature of Intelligent RF management is the support of black-hole compensation. The controller will adjust neighboring Access Points to a failed AP compensating for the resulting

void created by the failed Access Point. This helps in the system availability to users affected by any AP going offline.

► Intelligent control of airtime fairness

When legacy 802.11b and 802.11g devices are used on a wireless network or if some devices are an extended distance from the Access Points, the negotiation rates will be low, causing a large number of users to experience a long WLAN access delay, low rates, or poor overall AP performance. The AP performance problem in a low rate access environment cannot be resolved by simply employing rate control and traffic shaping. With Amer Acuity™ APs this problem is addressed with intelligent control for airtime fairness which ensures that a user can always enjoy the same WLAN experience in the same location, no matter what type of device is being used. The intelligent control of devices based on airtime fairness greatly improves the performance of both the client and the entire network. It enables all clients with high data transmission rates to attain strikingly higher performance while low-rate clients are mostly unaffected. The performance will be even higher on an open wireless network. Once high-rate clients finish data transmission, fewer clients will be transmitting data on the wireless network contributing to less contention on the network, thereby greatly improving overall AP performance.

► Intelligent load balancing

With most wireless systems, a wireless client will select an Access Point based on the signal strength of available Access Points. With this type of uncontrolled access a large number of clients could be connected to the same AP simply because the AP provided a stronger signal. As more clients are connected to an AP, the bandwidth available to each client will be reduced, thereby greatly affecting user experience. Amer Acuity™ wireless products support intelligent load balancing based on:

- traffic
- number of users
- frequency bands
- signal strength

WS6222

Amer Acuity™ Wireless Controller with 128AP License max 1024AP Support

► Intelligent Device Identification

Amer Acuity™ AP/Controller system supports adaptive portal authentication pages that are able to intelligently detect the device platform and automatically adjust the page resolutions to provide best results for mobile devices. Device support include Apple iOS, Android and Windows.

This active platform identification also can determine the type of device that is connected wither mobile phone, tablet or PC and implement dynamic policy control of devices based on the device type allowing intelligent user control.

► Comprehensive support for IPv4/v6 dual-stack networks

Powered by Amer's cutting-edge IPv6 technology, Amer Acuity™ APs may be deployed on an IPv6 network, with IPv6 tunnels established through auto negotiation between a wireless Controller and an AP. When the wireless Controller and the AP completely operate in IPv6 mode, the wireless Controller can still correctly identify IPv4 devices and process IPv4 packets from wireless clients. Featuring flexible adaptability to IPv4/6, Amer Acuity™ APs cater to complex applications involved in migration from an IPv4 network to an IPv6 network. They not only provide IPv4 service to customers on an IPv6 network, but also enable users on an IPv4 network to log in to the network through the IPv6 protocol.

► Network-wide seamless roaming

Amer wireless Controllers support an advanced wireless cluster technology, which enables multiple Controllers to synchronize online connection information and roaming records of all users to each other in real time. This technology implements not only L2/L3 seamless roaming inside a wireless Controller but also fast roaming across wireless Controllers. As client IP address re-authentication is not required in the roaming process, the real-time service level for roaming is greatly improved.

Secure and Controllable Wireless Network

► User isolation

The WS6222 supports the isolation of wireless users from one another. With the user isolation function enabled, wireless clients cannot directly communicate with each other but can only access an upstream wired network. This provides additional security in a wireless deployment.

► Wireless intrusion detection and intrusion defense

Amer wireless APs support wireless intrusion detection and intrusion defense features. This feature allows for the detection of unauthorized wireless devices. Blacklist and white list can also be created improving security management.

► 32 SSID / BSID

Under the management of the WS6222, each AP supports a maximum of 32 WLANs to implement multi-layer multi-service management of wireless users. Each WLAN supports access control and uplink/downlink rate limit based on MAC or IP addresses. These WLANs may be bound to virtual local area networks (VLANs). Different authentication and accounting policies can be implemented on the separate SSID/BSID. 16 SSID/BSID are supported on each band (2.4GHz and 5GHz) creating a maximum of 32 SSID/BSID. WLAN environment.

► Operational-level permission management

An SSID-based user permission management mechanism enables a network to be divided into multiple virtual wireless networks based on multiple SSIDs according to actual application requirements. This mechanism sets specific management and viewing permissions for specific users, so that users are completely isolated from one another in terms of operation and management.

► Secure user admission

Amer Acuity™ APs may be used with wireless Controllers to provide multiple secure access, authentication, and accounting mechanisms for various application environments. These mechanisms include:

- 802.1x authentication
- Captive portal authentication, including built-in portal, external portal, and custom portal authentication modes
- MAC address authentication
- LDAP authentication
- WAPI encryption and authentication
- Wired/wireless integrated authentication and accounting

WS6222

Amer Acuity™ Wireless Controller with 128AP License max 1024AP Support

► Wireless SAVI

Source address validation (SAVI) technology is implemented to deal with spoofed packet attacks.

► PEAP user authentication

Protected Extensible Authentication Protocol (PEAP) authentication adds security to the wireless network.

► Secure access

An AP is usually deployed in a public area and requires a strict security mechanism to guarantee the legitimacy of access for all devices. The following secure access mechanisms are available to be applied on an Amer Acuity™ AP and an Amer Acuity™ Controller:

- AP MAC address authentication
- AP password authentication
- Bidirectional digital certificate authentication

► Real-time spectrum protection

Amer Acuity™ APs support a built-in RF collection module that integrates RF monitoring and real-time spectrum protection. By implementing communications and data collection through the respective AP, the RF collection module performs wireless environment quality monitoring, wireless network capability tendency evaluation, and unexpected-interference alarms. It actively detects and identifies RF interference sources (Wi-Fi or non-Wi-Fi) and provides a realtime spectrum analysis diagram. In addition, it can automatically identify interference sources and determine the locations of problematic wireless devices, ensuring that a wireless network attains optimal performance.

Easy-to-Manage Wireless Network

► AP plug-and-play

The WS6222 smart access controller can be seamlessly integrated with existing switches, firewalls, authentication servers, and other network devices. Amer Acuity™ APs are able to automatically discover Amer Acuity™ controllers like the WS6222 and support zero configuration creating a plug and play environment. The wireless Controller

undertakes all the management, control, and configuration of the APs. Network administrators do not need to separately manage or maintain a huge number of wireless APs. All actions, such as configuration, firmware upgrade, and security policy updating, are performed uniformly under the control of the wireless Controller.

► Remote probe analysis

The WS6222 supports remote probe analysis of Amer Acuity™ APs. It listens to and captures Wi-Fi packets in the coverage area. Data can be mirrored to a local analysis device in real time to help network administrators perform troubleshooting or for optimization analysis.

► Multiple management modes

The WS6222 supports various management modes such as command lines and web. It can be used to plan, deploy, monitor, and manage APs on the entire network centrally and effectively

WS6222

Amer Acuity™ Wireless Controller with 128AP License max 1024AP Support

Hardware Specifications

Service port:	<ul style="list-style-type: none"> • Twelve 10/100/1000 Base-T ports • Eight fixed SFP GE ports • Two fixed SFP+ 10 GE ports
Management port:	<ul style="list-style-type: none"> • One 10/100Base-T management Ethernet port (RJ-45) • One console port (RJ-45) • Environment monitoring alarm port (RJ-45) • CF card slot
Power supply:	<ul style="list-style-type: none"> • AC 110 V to 240 V, 50 Hz to 60 Hz
Power consumption	<ul style="list-style-type: none"> • ≤ 75 W
Working temperature:	<ul style="list-style-type: none"> • 0° - 55° C
Storage temperature:	<ul style="list-style-type: none"> • -40° - 70° C
Working/Storage RH:	<ul style="list-style-type: none"> • 5% to 90% (non-condensing)
Switching capacity	<ul style="list-style-type: none"> • 128 Gbps
Dimensions:	<ul style="list-style-type: none"> • 440 x 254 x 66.6mm

Software Specifications

Base number of manageable APs:	• 128
Maximum number of manageable APs	• 1024
Number of manageable ACs in a cluster	• 64
AP upgrade step:	• 128
Maximum number of concurrent wireless users:	• 32K
VLANs	• 4K
ACL	• 4K
MAC address list	• 32K
ARP table:	• 32k
Switching time during roaming	• < 30 ms

L2 protocols:	<ul style="list-style-type: none"> • IEEE802.3 (10Base-T), IEEE802.3u (100Base-TX), IEEE802.3z (1000BASE-X) IEEE802.3ab (1000Base-T), IEEE802.3ae (10GBase-T) IEEE802.3ak (10GBase-CX4), IEEE802.1Q (VLAN) IEEE802.1d (STP), IEEE802.1W (RSTP), IEEE802.1S (MSTP) IEEE802.1p (COS) IEEE802.1x (Port Control), IEEE802.3x (Flow Control) IEEE802.3ad (LACP), Port Mirror IGMP Snooping, MLD Snooping QinQ, GVRP, PVLAN Broadcast storm control
L3 protocols:	<ul style="list-style-type: none"> • Static Routing • RIPv1/v2, OSPF, BGP, VRRP, IGMP v1/v2/v3 • ARP, ARP Proxy • PIM-SM, PIM-DM, PIM-SSM
Wireless protocols:	<ul style="list-style-type: none"> • 802.11, 802.11a, 802.11b, 802.11g, 802.11n, 802.11d, 802.11h, 802.11i, 802.11e, 802.11k
CAPWAP protocol:	<ul style="list-style-type: none"> • Supports L2/L3 network topology between an AP and an AC. • Enables an AP to automatically discover an accessible AC. • Enables an AP to automatically upgrade its software version from AC. • Enables an AP to automatically download configurations from AC.
IPv6 protocols:	<ul style="list-style-type: none"> • IPv4/v6 dual-stack, manual tunnel, ISATAP, 6to4 tunnel, IPv4 over IPv6 tunnel, DHCPv6, DNSv6, ICMPv6, ACLv6, TCP/UDP for IPv6, SOCKET for IPv6, SNMP v6, Ping /Traceroute v6, RADIUS, Telnet/SSH v6, FTP/TFTP v6, NTP v6, IPv6 MIB support for SNMP, VRRP for IPv6, IPv6 QoS, static routing, OSPFv3, IPv6 SAVI
High reliability:	<ul style="list-style-type: none"> • 1+1 fast backup • N+1 backup • N+N backup • Portal 1+1 backup • DHCP server hot backup

WS6222

Amer Acuity™ Wireless Controller with 128AP License max 1024AP Support

Software Specifications

RF Management Features:

- Setting country codes
- Manually/automatically setting the transmit power
- Manually/automatically setting the working channel
- Automatically adjusting the transmission rate
- Blind area detection and repair
- RF environment scanning, which enables a working AP to scan the surrounding RF environment
- RF interference detection and avoidance
- 11n-preferred RF policy
- SSID hiding
- 20 MHz and 40 MHz channel bandwidth configuration
- Airtime protection in hybrid access of 11bg and 11n terminals
- Terminal-based airtime fairness scheduling
- Spectral analysis
- Terminal locating (A terminal locating algorithm can be embedded in the AC)
- Spectral navigation (5 GHz preferred)
- 11n only
- SSID-based or Radio-based limit on the number of users
- User online detection
- Automatic aging of traffic-free users
- Prohibiting the access of clients with weak signals
- Remote probe analysis
- Forced roaming of clients with weak signals

Security:

- 64/128 WEP, dynamic WEP, TKIP, CCMP, and SMS encryption
- 802.11i security authentication and two modes (Enterprise and Personal) of 802.1x and PSK
- WAPI encryption and authentication
- LDAP authentication
- MAC address authentication
- Portal authentication, including built-in portal, external portal, and custom portal authentication modes
- PEAP user authentication

- Forwarding security control, such as frame filtering, white list, static blacklist and dynamic blacklist
- User isolation
- Periodic Radio/SSID enabling and disabling
- Access control of free resources
- Secure admission control of wireless terminals
- Access control of various data packets such as MAC, IPv4, and IPv6 packets
- Secure access control of APs, such as MAC authentication, password authentication, or digital certificate authentication between an AP and an AC
- Radius Client
- Backup authentication server
- Protection against ARP spoofing
- DHCP security
- Wireless SAVI
- User access control based on AP locations
- Wireless intrusion detection system (WIDS) and wireless intrusion prevention system (WIPS)
- Protection against flooding attacks
- Protection against spoofing attacks

Forwarding:

- IPv6 access and forwarding; constructing IPv6 WLAN access service on an IPv4 network; providing IPv4 WLAN access service on an IPv6 network; and constructing private IPv6 WLAN network service on an IPv6 network
- Fast L2/L3 roaming between APs served by the same AC
- Fast L2/L3 roaming between APs served by different ACs
- IPv4 and IPv6 multicast forwarding
- WDS AP

WS6222

Amer Acuity™ Wireless Controller with 128AP License max 1024AP Support

Software Specifications

QoS:

- 802.11e (WMM); and 4-level priority queues, ensuring packets, such as voice and video services, are transmitted first
- Ethernet port 802.1P identification and marking
- Mapping from wireless priorities to wired priorities
- Mapping of different SSIDs/VLANs to different QoS policies
- Mapping of data streams that match with different packet fields to different QoS policies
- Access control of MAC, IPv4, and IPv6 data packets
- Load balancing based on the number of users
- Load balancing based on user traffic
- Load balancing based on frequency bands
- CAC based on the number of users
- Bandwidth limit based on APs
- Bandwidth limit based on SSIDs
- Bandwidth limit based on terminals
- Bandwidth limit based on specific data streams
- Power saving mode
- Multicast-to-unicast mechanism
- Automatic emergency mechanism of APs
- Intelligent identification of terminals

Management:

- Web management
- Configuration through a console port
- SNMP v1/v2c/v3
- Both local and remote maintenance
- Local logs, Syslog, and log file export
- Alarm
- Fault detection
- Statistics
- Login through Telnet
- Login through SSH
- Dual-image (dual-OS) backup
- Hardware watchdog

- AC cluster management; automatic information synchronization between ACs in a cluster, and automatic or manual push of configuration information
- SSID-based user permission management mechanism

Related Products:

WAP38DC	Indoor Wireless 802.11n Dual Concurrent Access Point with Internal Antennas
WAP42DC	Indoor Wireless 802.11ac Dual Concurrent 2x2 Access Point with Internal Antennas
WAP43DC	Indoor Wireless Acuity™ 802.11ac Dual Concurrent 3x3 Access Point with Internal Antennas
WAP33DO	Outdoor Wireless 802.11n Amer Acuity™ Wireless Access Point
WAP33DC	Indoor Wireless 802.11n Dual Concurrent Access Point with Internal Antennas
WS6002	Amer Acuity™ Wireless Controller with 16AP License max 128AP
WS6028	Amer Acuity™ Wireless Controller with 32AP License max 256AP

WS6222

Amer Acuity™ Wireless Controller with 128AP License max 1024AP Support

Typical Applications:

AC in OFF-Line Mode

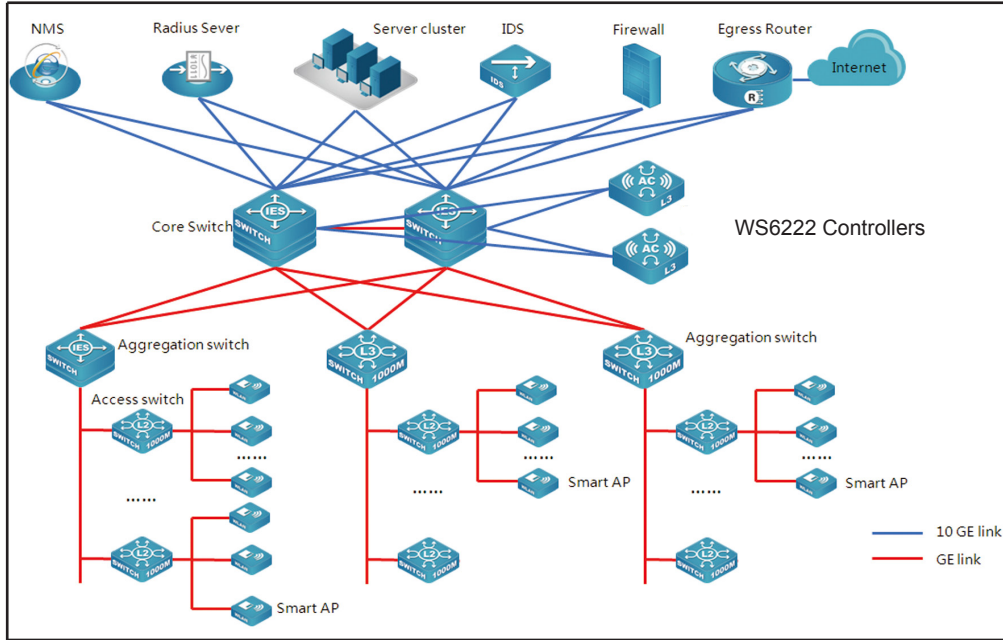

AC in IN-Line Mode

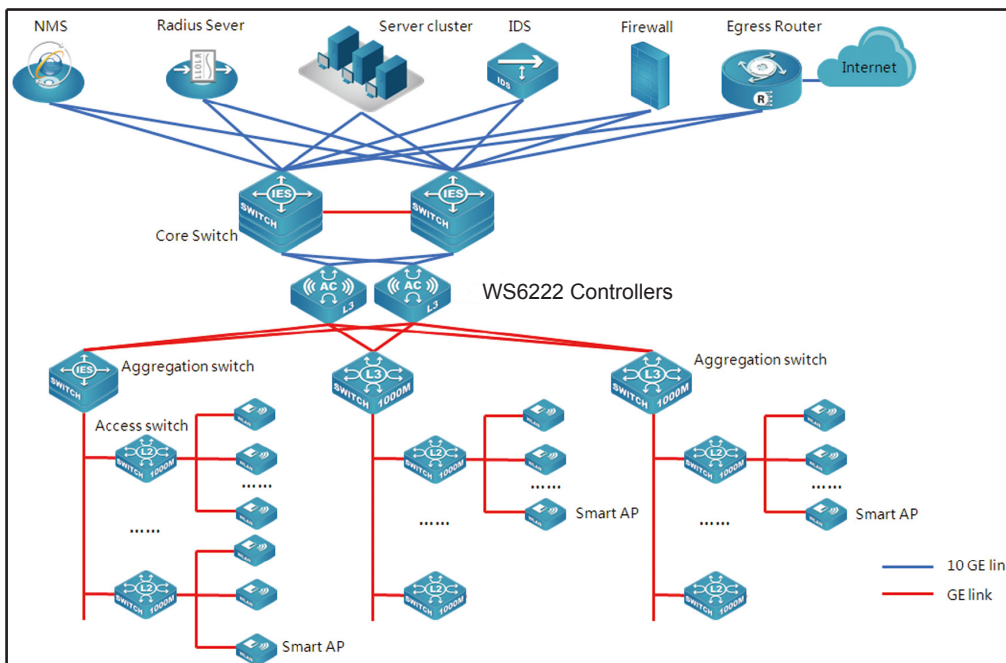

www.amer.com
sales@amer.com
 1-800-262-9703

Specifications subject to change without notice. Errors and omissions excepted. All trademarks are properties of their respective owners.