

FlexView™ Series

display stands and carts

a collection of display stands and carts that are easy-to-integrate, cost-effective solutions for corporate, hospitality & education environments

features:

- Engineered for long-lasting, durable use with a steel subframe; certified for strength and safety
 - Rugged casters on cart models provide long-lasting use and seamless maneuverability, even when wheeling over door thresholds
- Designed with flexibility for mounting displays and other system components
 - Models with electric lift display height adjustment for optimal ergonomics, or manual display height positioning
 - Engineered with the Lever Lock™ system for small device mounting. Standard (non-electric lift) models include two rackspaces for additional equipment mounting
- Designed to be both user- and installer-friendly
 - Simple and quick maintenance with easy-access key locked doors
 - Base designed for unimpeded, up close display interaction
- UL Listed in US and Canada



specifications:

FlexView™ Series Display carts and Stands shall be Middle Atlantic Products model #FVS-___ (see chart for available models). Overall dimensions of FVS shall be ___"H x 43.5" W x 30.7"D (see drawing). FVS display height adjustability shall be from ___ to ___ (refer to chart). FVS height adjustability method shall be ___ (Manual, Electric, refer to chart). FVS shall have ___ (4" diameter directional locking casters, leveling feet, refer to chart) FVS series shall have a ___ (white, black, refer to chart) powdercoat and thermolaminate finishes. FVS Series shall have a steel subframe. FVS Series shall provide 2 rackspaces (manual height adjustment model only) with a maximum of 46.1" usable space. FVS shall include an accessory basket and Lever Lock system. FVS shall have knockouts for six AVIP panels and one RACO 440 Knockout. FVS shall accommodate one display and have horizontal VESA mounting patterns of 300, 400, 500, 600 and 800, and a vertical VESA pattern of 400. FVS shall have an overall weight capacity of 190 lb., with no more than 175 lb. for the monitor and 50 lb. mounted inside. FVS shall include a 15 Amp power strip with surge protected 8 outlets and a 10' SignalSAFE™ cord. FVS shall be UL Listed in the US and Canada. FVS shall be GREENGUARD Gold Certified. FVS shall comply with requirements of RoHS EU Directive 2002 / 95 / EC. FVS shall be manufactured by an ISO 9001 and ISO 14001 registered company. FVS shall be warranted to be free from defects in material or workmanship under normal use and conditions for the 7 years.

Customizable specification clips available at middleatlantic.com

EIA/TIA COMPLIANT



PRODUCT CERTIFIED FOR
LOW CHEMICAL EMISSIONS
UL.COM/GG
UL 2818

options:

- Soundbar bracket shall be model # FVS-SBBU
- Camera Mount shall be FVS-CMTB-128-BK (black finish) and FVS-CMTB-128-WH (white finish)

what **great systems** are built on.™

A Group brand | legrand

Middle Atlantic Products
middleatlantic.com | middleatlantic.ca

96-01198 / rev c / 1/5/15

FlexView™ Series

basic dimensions, manual adjustment

all dimensions in inches unless otherwise noted [all dimensions in brackets are in millimeters]

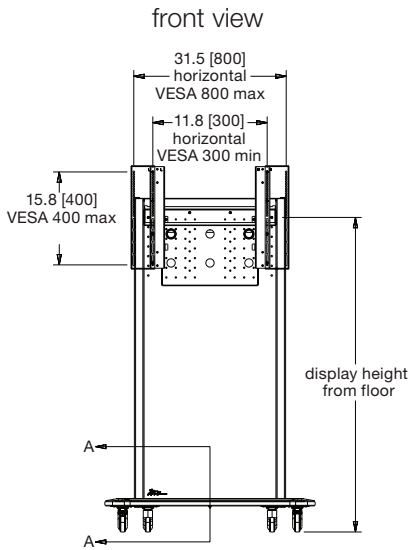
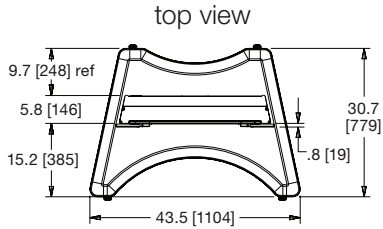

Part #	Display Height Adjustability Method	Casters or Leveling Feet	Color	Display Height From Floor (See Note 2)		Overall Height w/out Monitor Mounting Brackets & Monitor
				Minimum	Maximum	
FVS-800SC-WH	manual	casters	white	53.0 [1346]	65.0 [1651]	68.9 [1751]
FVS-800SC-BK	manual	casters	black	53.0 [1346]	65.0 [1651]	68.9 [1751]
FVS-800S-WH	manual	leveling feet	white	48.6 [1235]	60.6 [1539]	64.5 [1638] - 65.0 [1651]
FVS-800S-BK	manual	leveling feet	black	48.6 [1235]	60.6 [1539]	64.5 [1638] - 65.0 [1651]

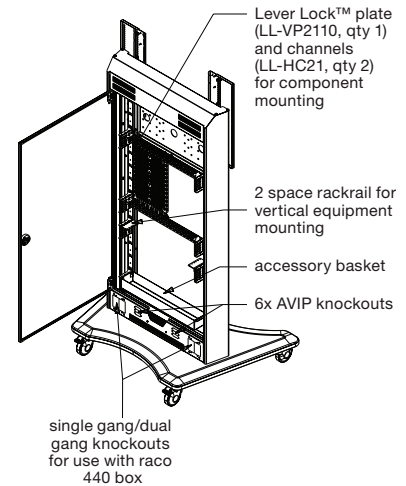
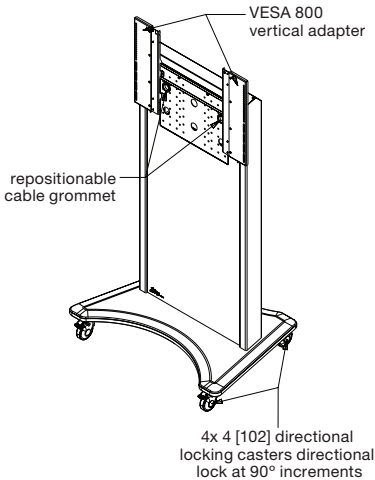
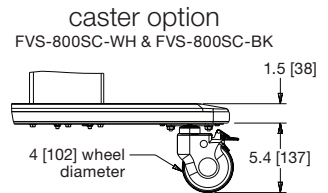
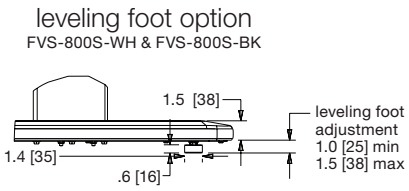
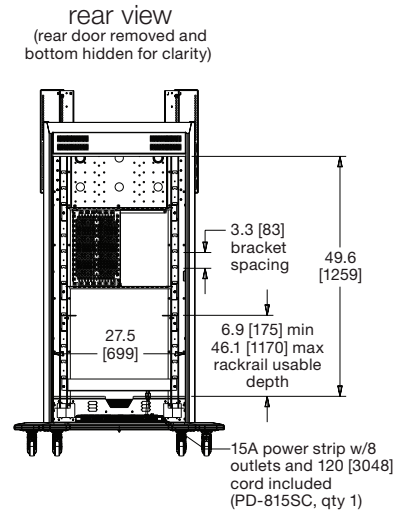
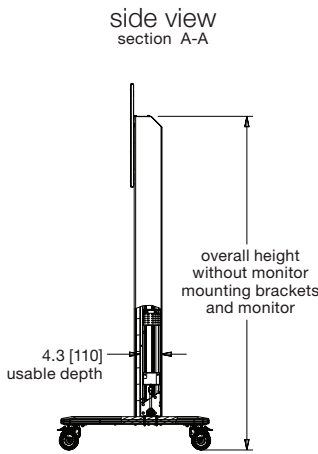

Notes:

1. Horizontal VESA Pattern has Fixed Positions at 300, 400, 500, 600, and 800 VESA Locations
2. Display Height is Adjustable in Increments of 2.0 [51] Max Adjustment is 12.0 [305]
3. Weight Capacity: 50 Lb [23 Kg] Inside Max / 175 Lb [79 Kg] Monitor Only Max / 190 Lb [86 Kg] Monitor and Accessories Max

what great systems are built on.™



A Group brand | legrand



Middle Atlantic Products

middleatlantic.com | middleatlantic.ca

FlexView™ Series

basic dimensions, electric adjustment

all dimensions in inches unless otherwise noted [all dimensions in brackets are in millimeters]

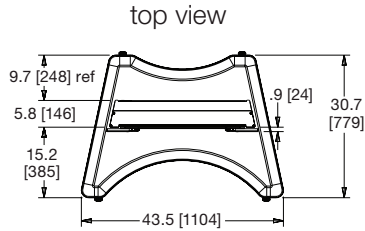

Part #	Display Height Adjustability Method	Casters or Leveling Feet	Color	Display Height From Floor (See Note 2)		Overall Height w/out Monitor Mounting Brackets & Monitor
				Minimum	Maximum	
FVS-800ESC-WH	electric	casters	white	50.0 [1270]	65.0 [1651]	68.9 [1751]
FVS-800ESC-BK	electric	casters	black	50.0 [1270]	65.0 [1651]	68.9 [1751]
FVS-800ES-WH	electric	leveling feet	white	45.6 [1158]	60.6 [1539]	64.5 [1638] - 65.0 [1651]
FVS-800ES-BK	electric	leveling feet	black	45.6 [1158]	60.6 [1539]	64.5 [1638] - 65.0 [1651]

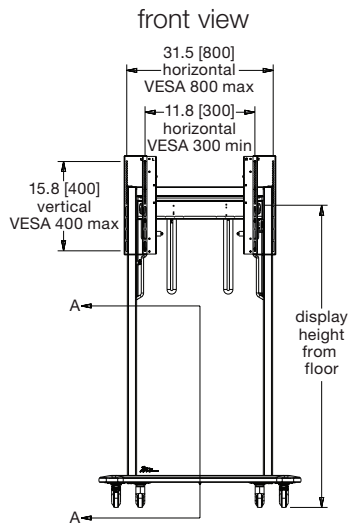

side view

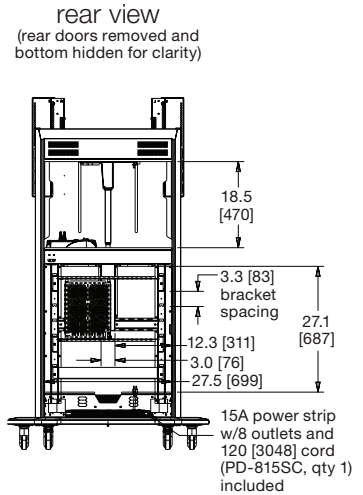
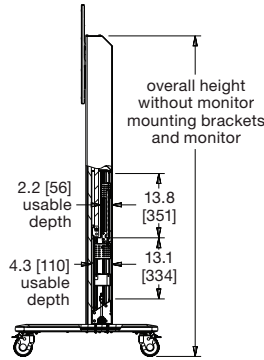

leveling foot option
FVS-800ES-WH & FVS-800ES-BK

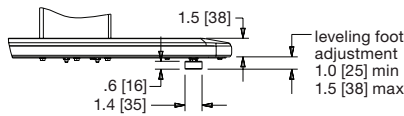

caster option
FVS-800ESC-WH & FVS-800ESC-BK

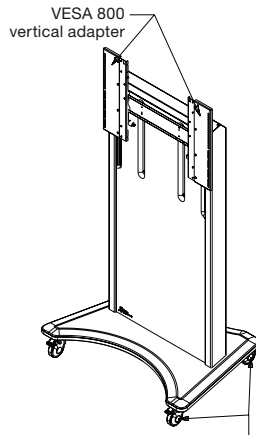
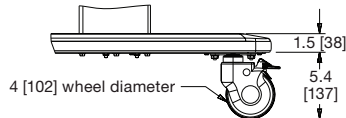

4x 4 [102] directional locking casters
directional lock at 90° increments

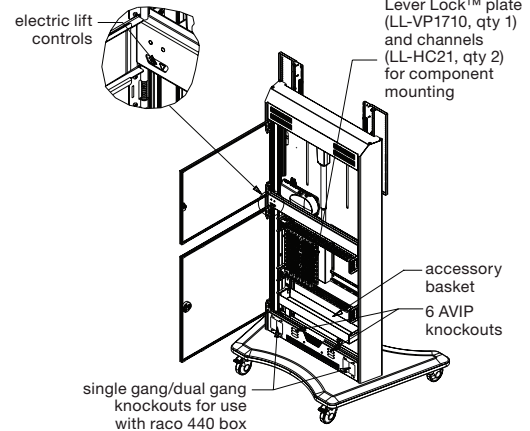

Notes:

- Horizontal VESA Pattern has Fixed Positions at 300, 400, 500, 600, and 800 VESA Locations
- Display Height max adjustability is 15.0 [381]
- Weight Capacity: 50 Lb [23 Kg] Inside Max / 175 Lb [79 Kg] Monitor Only Max / 190 Lb [86 Kg] Monitor and Accessories Max
Input Voltage: 120VAC 60Hz / Input Power: 200WATTS / Power Consumption: 0.1W Standby Mode

what great systems are built on.™

FlexView™ Series

camera mount basic dimensions

all dimensions in inches unless otherwise noted [all dimensions in brackets are in millimeters]

front view

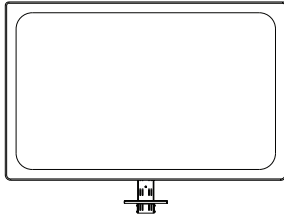

side view

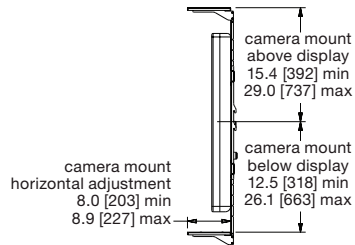

rear view

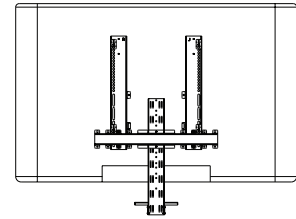

8 [203] x 8 [203]
camera mounting plate

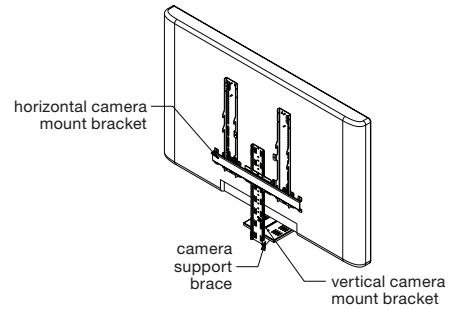
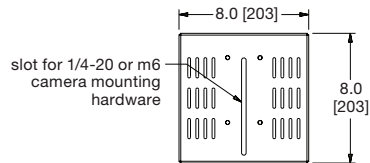
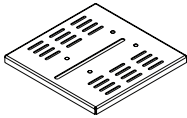

12 [305] x 8 [203]
camera mounting plate

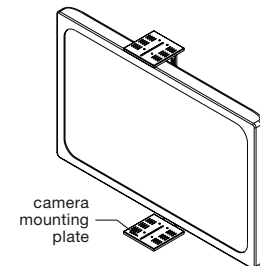
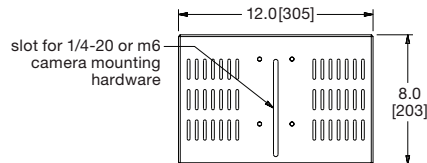
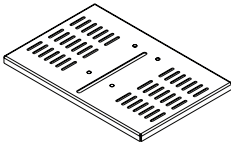

camera mounting plate
camera mount shown above and below display for representation only

Notes:

1. Camera Mount Adjusts Vertically in Increments of 1.9 [49]
2. Camera Mount Includes Both 8X8 and 8X12 Camera Mounting Plates.
3. Weight Capacity: 20 Lb [9 Kg]
4. Camera Mount and Soundbar Mount Can Not Be Mounted Together in The Same Position But They Can Be Mounted in Opposite Positions.
For Example, Sound Bar Mount Mounted Above Monitor and Camera Mount Mounted Below Monitor
5. Part Numbers: FVS-CMTB-128-BK (Black) and FVS-CMTB-128-WH (White)

FlexView™ Series

soundbar mount basic dimensions

all dimensions in inches unless otherwise noted [all dimensions in brackets are in millimeters]

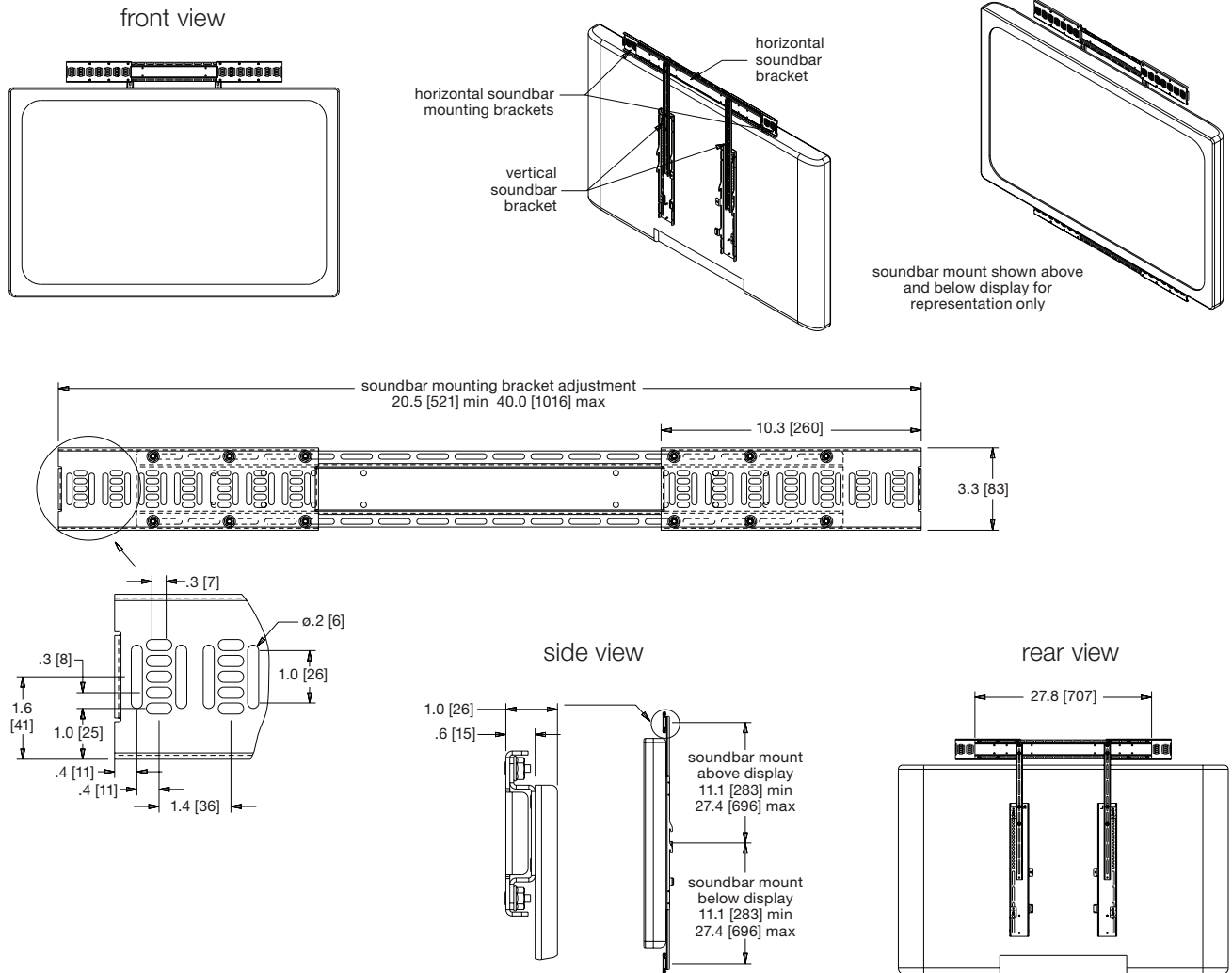

Notes:

1. Weight Capacity: 20 Lb [9 Kg]
2. Camera Mount and Soundbar Mount can not be Mounted Together in the Same Position but they can be Mounted in Opposite Positions for example, Sound Bar Mount Mounted Above Monitor and Camera Mount Mounted Below Monitor
3. Part Number: FVS-SBB

what **great systems** are built on.™