

eBridge1CRT IP over Coax Solution

Description

Altronix eBridge1CRT IP over Coax transceiver and receiver kit is designed to enable fast 10/100Base-T Ethernet digital communication over coax cable. These plug and play units facilitate system upgrades from analog to IP cameras/devices utilizing existing legacy Coax and eliminating the costs and labor associated with installing new network cabling. In addition, data transmission is extended up to 610m (over five times the 100m Ethernet maximum length), eliminating the need for repeaters. eBridge units transmit composite video signal with Ethernet data simultaneously.



eBridge1CR
and eBridge1CT

Key Features

- Throughput is rated to pass 25Mbps at distances up to 500m.
- Eliminates the costs and labor associated with installing new network cabling.
- Retrofit digital IP cameras in an analog CCTV installation.
- Transmits composite video signal with Ethernet data simultaneously.
- Incorporates *sloc™ (Security Link over Coax) technology.
- Works with Megapixel, HD720, HD1080 & VGA (SD) cameras.
- Extends Network link distance in an industrial environment.
- Upgrades deployed CCTV Coax to a digital network for Retail, Casinos, Airports, Schools, Hospitals, etc.
- UL Listed in the U.S. and Canada.
- CE Approved,
- C-Tick compliant.
- SLOC* compliant.
- Lifetime Warranty

Typical Operation Diagram

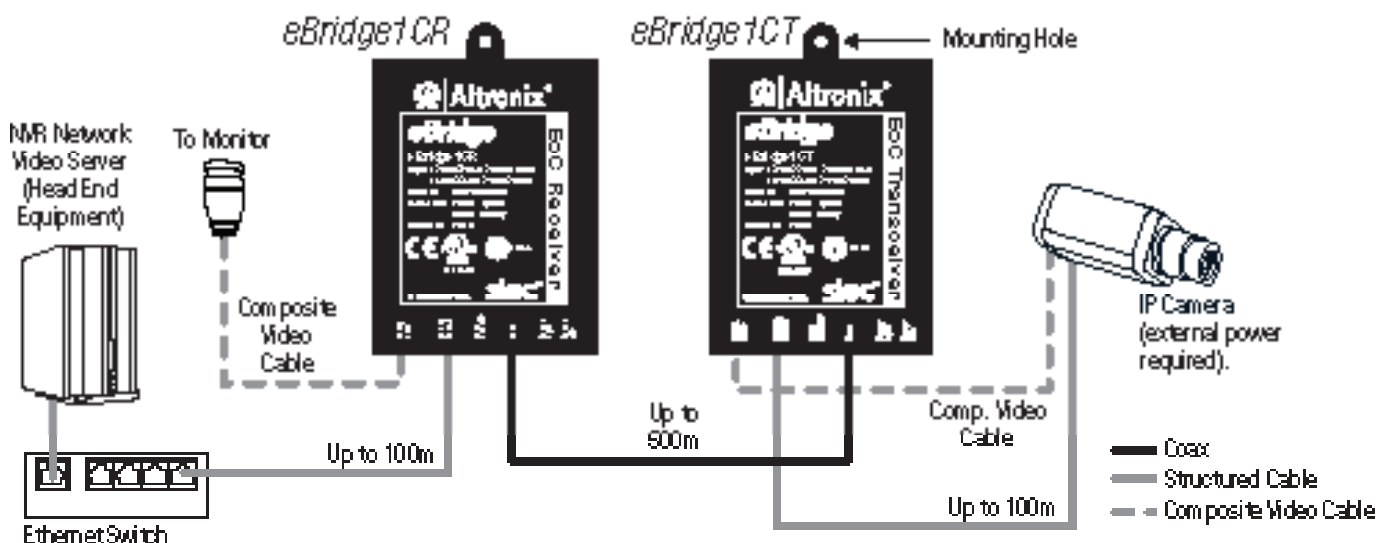

eBridge1CRT IP over Coax Solution

Specifications

Input

12VDC to 24VDC Class 2 power supply (polarity not observed) or
16VAC to 24VAC Class 2 plug-in transformer.

Ethernet

Connectivity: RJ45, auto-crossover.
Wire type: 4-pair Cat-5 or better structured cable.
Distance: up to 100m.
Speed: 10/100BaseT, half/full duplex, auto negotiation.

Coax

Throughput is rated to pass 25Mbps of data at distances up to
500m with proper headend equipment which supports Megapixel,
HD720, HD1080.
Connectivity: BNC, RG-59/U or similar.

Indicators (LED)

Blue LED: Coax link connection.
Green LED: Power ON.
Yellow and Green LED (RJ45):
IP Link status, 10/100Base-T/active.

Agency Listings

UL/cUL UL 60950-1
(Information Technology Equipment).
CE European Conformity.
C-Tick compliant.

Physical and Environmental

Dimensions (W x L x H)
eBridge1CR and eBridge1CT:
2.5" x 3.8" x 1" (63.5mm x 96.5mm x 25.4mm).

Weight (approx.)

Product Weight 0.4 lbs. (0.18 kg).
Shipping Weight 1 lbs. (0.45 kg).

Temperature

Operating -10°C to 50°C (14°F to 122°F).
Storage -20°C to 70°C (-4° to 158°F).

Relative Humidity 85% +/-5%.

Operating Altitude: -304.8 to 2,000m.