



Quam

**QH16T**

**PAGING HORN**

Compression Type, Double Re-Entrant Horn Loudspeaker,  
16W-25/70V Rotary Select Transformer

**GENERAL DESCRIPTION**

The QH16T is a compression type, double re-entrant horn loudspeaker with an integrated 16W-25/70V rotary select transformer and an adjustable mounting base. Tan, enamel finish.

**INTENDED USE - Indoor or Protected Outdoor Environment**

<b>Program Material</b>	Signal tones, and voice
<b>Installation</b>	Horizontal or Vertical Alignment

**AUDIO SPECIFICATIONS**

<b>Speaker Type</b>	Compression, Double Re-Entrant Horn
<b>Average Sensitivity</b>	110 dB SPL, 1W/ 1M
<b>Loudspeaker Power Rating</b>	16W RMS, EIA 426A Standard
<b>Calculated Output</b>	121 dB SPL, 16W/ 1M
<b>Frequency Response</b>	450 Hz - 15 kHz EIA 426A Standard
<b>Nominal Coverage Angle</b>	110° Included Angle, -6 dB / 2 kHz, Half space
<b>Audio Connection</b>	Screw Terminals
<b>Transformer</b>	25/70V 16W-5 Tap, Rotary Select (16W, 8W, 4W, 2W, 1W)



**RECOMMENDED QUAM COMPONENTS**

<b>KIT# 104</b>	Three (3) Conduit Entry Plates
-----------------	--------------------------------

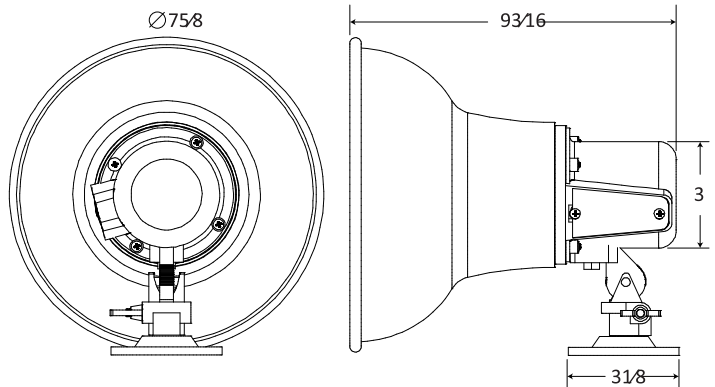

<p>Recommended construction sequences, installation instructions, and A&amp;E Specifications are available in various formats in the QUAM Architects' and Engineers' Resources section on the web at: <a href="http://www.QuamSpeakers.com">www.QuamSpeakers.com</a></p>				<p>QUAM-NICHOLS COMPANY, INC. 234 East Marquette Rd. Chicago, IL. 60637 Tel: 1-800-NEED-NOW (800-633-3669) Fax: 1-888-NEED-NOW (888-633-3669) e-mail: <a href="mailto:NeedNow@QNC.com">NeedNow@QNC.com</a> <a href="http://www.QuamSpeakers.com">www.QuamSpeakers.com</a></p>
<p>© 2013 Quam-Nichols Company reserves the right to make changes and/or improvements to its products at any time and without notice.</p>				