

OPTIONAL EQUIPMENT

Additional Units (sold separately)



MODEL #22 TABLE TOP LECTERN

This versatile, portable table top lectern, can be used on its own or as a floor lectern with the optional base (sold separately). 5/8" stain and scratch resistance thermofused melamine laminate on MDF. Paper/book stop included. Dimensions: 23 3/4" W x 13 3/4" H x 19 1/8" D.

MODEL #112 LECTERN BASE-AV CART

Converts your TABLE TOP Lectern to a FULL FLOOR Lectern or use as an AV cart for your presentation equipment. Includes shelf and four easy roll castors, with two locking. Dimensions: 21 1/8" W x 33 3/4" H x 17 1/2" D.

Available Color Options

Medium Oak • Light Oak • Mahogany • Walnut

BRASS READING LAMP / #BRL

Attach an elegant brushed brass reading lamp to the reading table of your new Speaker Stand. Not only will you shed light on the subject, but you will add pizzazz to your new stand.



OKLAHOMA SOUND CORP.

149 Entin Road, Clifton, NJ 07014
Tel: 973-594-9000 • Fax: 973-594-9339
e-mail: info@oklahomasound.com
Web-Site www.oklahomasound.com



Full Floor Lectern

ASSEMBLY MANUAL



MODEL #222

INTRODUCTION

The model 222 full floor lectern is attractive and durable: this full floor lectern is made of 3/4" stain and scratch resistant thermo-fused melamine laminate on flakeboard. Full sized reading surface, shelf and paper/book stop built in. Floor glides provided. Assembly required.

Dimensions: 23" W x 46½" H x 16" D.

Manufacturers Warranty

Our lectern undergoes the most rigid and exacting tests for superior quality and performance before leaving the factory. Our lectern is made in America by American craftsmen. Oklahoma Sound Corporation warrants this product to be free from defective material and workmanship for two years from the date of resale by an authorized Oklahoma Sound distributor. Oklahoma Sound will replace defective parts and repair malfunctioning products under this warranty when the defect occurs under normal installation and use, provided the unit is returned to our factory via prepaid transportation after direct authorization and approval by Oklahoma Sound. This warranty provides that examination of the returned product must disclose in our judgment, a manufacturing defect. This warranty does not extend to any product which has been subject to misuse, neglect, accident, improper installation, or where the serial number has been removed or defected and is given in lieu of any other warranty implied or expressed and will not cover any consequential damages.

- 5) Once again go over all the cams and check to make sure the lectern is sturdy.

Congratulations! You have successfully assembled your lectern, which if properly cared for should give you long and satisfactory usage (diagram "F").

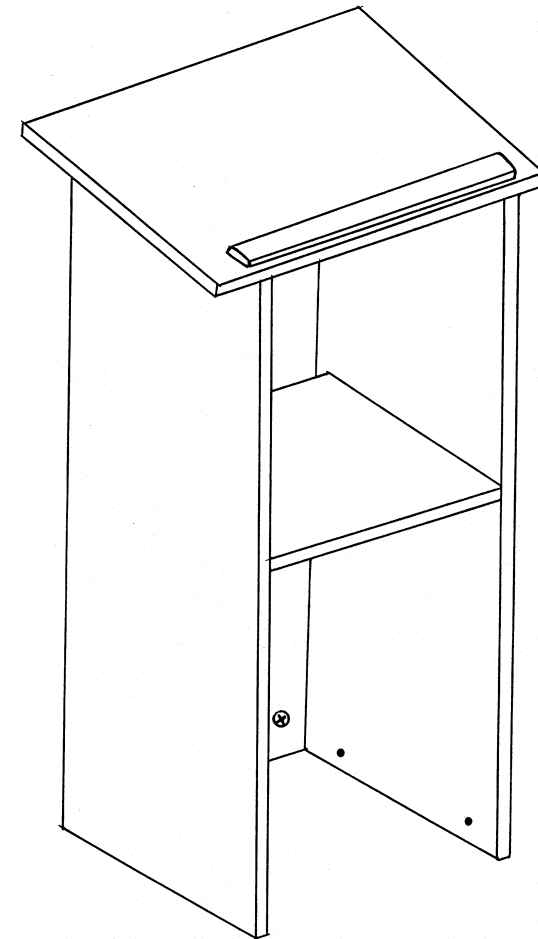
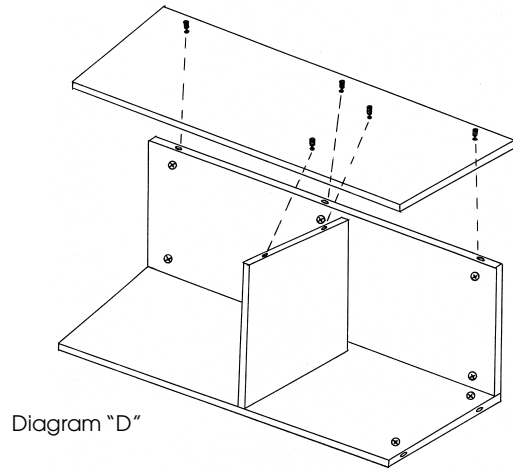
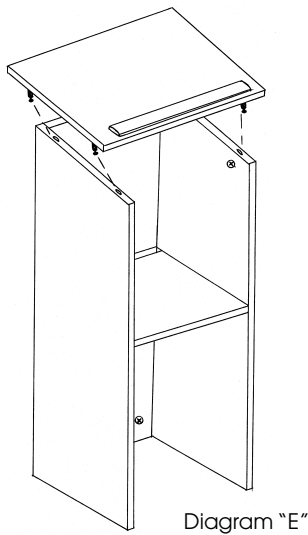

Diagram "F"

- 3) Now apply the left side panel to the semi assembled unit. Be sure to align the cam bolts to the holes on both the front panel and the shelf. Tighten cams (diagram "D").



- 4) Stand the lectern up. Taking the reading surface of the lectern with the 4 installed cam-bolts facing down (the book stop will be facing up), align bolts with holes on the top edges. Once they are in place apply gentle pressure on the reading surface until it lies flat on all of the top edges, then tighten cams (diagram "E").



ASSEMBLY INSTRUCTIONS

Assembly Tips

- Do not use a sharp instrument such as a knife or screwdriver to open the packaging, as this may scratch or damage the unit.
- All assembly should be done on a clean protected surface such as carpet or the like.
- Make sure that you have all the required parts. (A list of all the parts is listed below).
- Read the instructions carefully and follow the diagrams to ensure an easy and correct assembly.

Tools Required

- #2 Phillips Head Screwdriver
- Hammer

Parts

- | | | |
|-----------------------|--|--|
| 14 Cams..... | | 1 Front Panel |
| 14 Cam Bolts..... | | 1 Right Panel |
| 4 Plastic Glides..... | | 1 Left Panel |
| | | 1 Shelf |
| | | 1 Reading Surface
(can be identified by bookstop
which is already installed) |

Example of Cam Lock Assembly

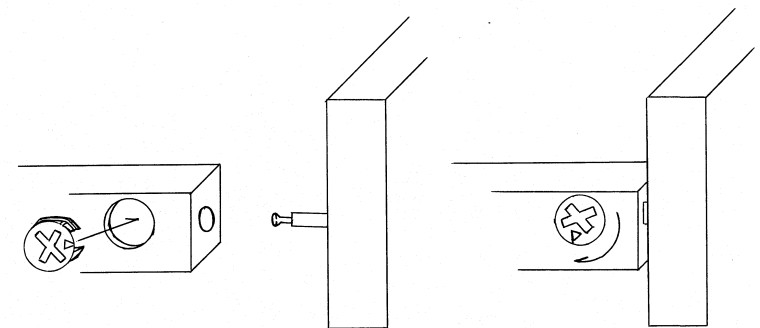

INSTALLATION OF HARDWARE

- 1) Lay out the wood panels as shown in diagram "A" (make sure the factory drilled holes are facing upwards). You can determine the top of the front panel by identifying the edge cut on an angle.
- 2) Identify the holes numbered "1" in Diagram A. Screw the bolts into the holes with the #2 Phillips head screwdriver. Be sure to tighten the screws all the way. **BE CAREFUL NOT TO OVER-TIGHTEN THE BOLTS AS THIS WILL STRIP THE WOOD!!**
- 3) The cams should be inserted in the larger holes as shown on diagram. MAKE SURE THE ARROW ON THE CAM IS POINTING TO THE CLOSEST EDGE AND ALIGNED WITH THE HOLE ON THE EDGE.
- 4) Using a hammer gently tap plastic glides into bottom edge as shown below (Diagram A). GLIDES SHOULD BE INSTALLED NO FURTHER THAN ONE INCH FROM END.

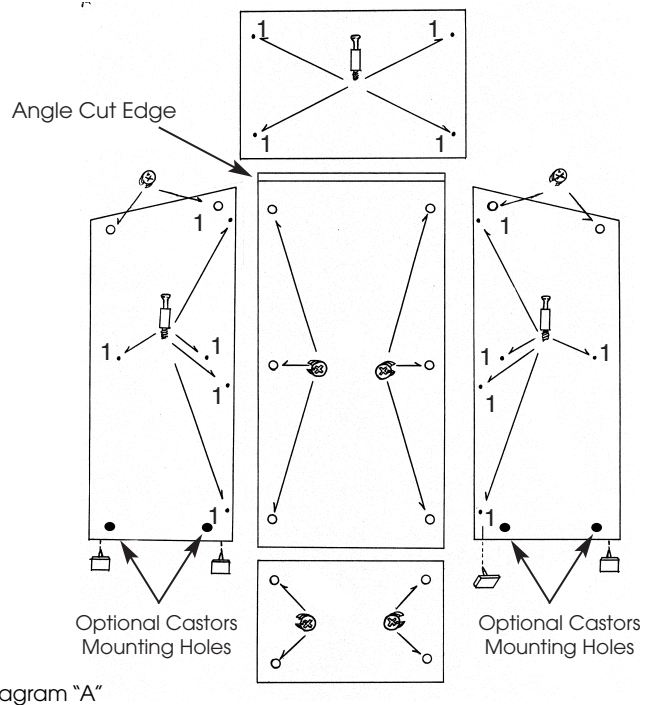

ASSEMBLY OF LECTERN

It is important that the instructions on the assembly are followed carefully

- 1) The first piece of equipment that will be installed will be the shelf. Make sure the cams face the bottom of the lectern. The two bolts in the center of the right hand panel will align with the two holes on the edge of the shelf (these holes reach until the cams) gently push the shelf down on to the cam bolts until the shelf is completely on the right side wood panel. Tighten the cams by turning clock-wise until locked. (Diagram "B")

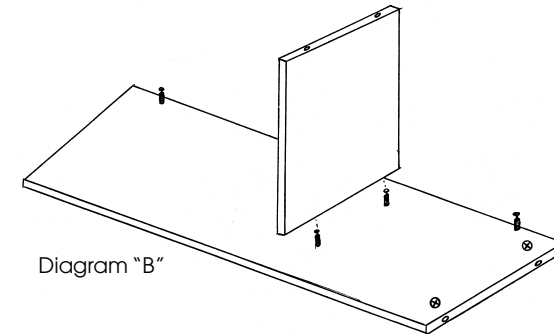

- 2) Align holes on the front panel edges with three cam bolts on the side panel, tighten cams. (Diagram "C")

