

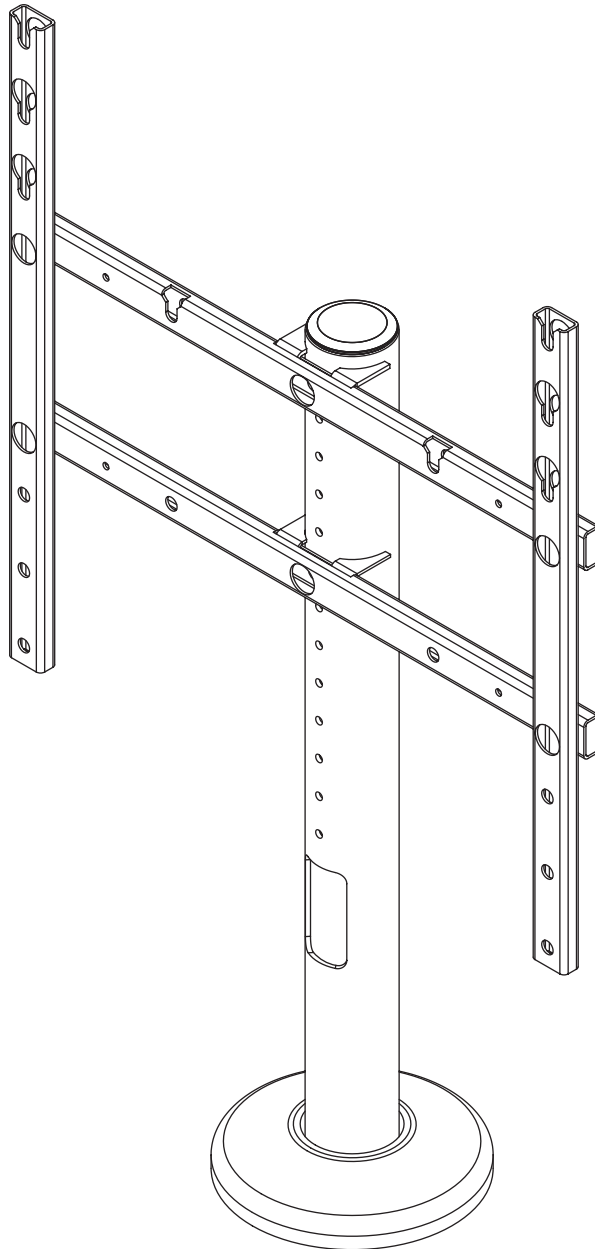

Installation and Assembly - Desktop Swivel Mount For 32" - 55" Flat Panel Display

Models: HP455



Max Load Capacity: 75 lb (34 kg)

NOTE: Read instruction sheet before you start installation and assembly.

Parts List		
Description	Qty	Part #
A support tube	1	091-1036
B base backer plate	1	090-1544
C desktop swivel base	1	090-1821
D tube cap	4	590-0970
E M5 x 10mm socket pin Type-F screw	4	520-1164
F thrust washer	1	590-1287
G slope nut	3	530-0035
H 1/4-20 x 3/4" hex head screw	2	520-1321
I M4 x 12mm serrated socket pin screw	4	510-1079
J 4mm allen wrench	1	560-9646
K 10-32 x 1/2" set screw	2	520-1614
L fender washer	4	540-1008
M 1/4-20 x 3" threaded rod	4	520-2585
N 1/4-20 lock nut	4	530-1021
O M6 x 12mm socket pin screw	4	510-1050
P M8 x 15mm socket pin screw	4	520-1068
Q #10 SAE flat washer	4	540-9400
R tube gusset	2	091-1032
S lower horizontal rail	1	091-1033
T vertical rail	2	091-1034
U 1/4" split washer	2	540-9402
V upper horizontal rail	1	091-1041
W M8 x 25mm socket pin screw	4	520-1101
X M8 x 35mm socket pin screw	4	520-1994
Y washer	8	540-9406
Z spacer	4	600-1215

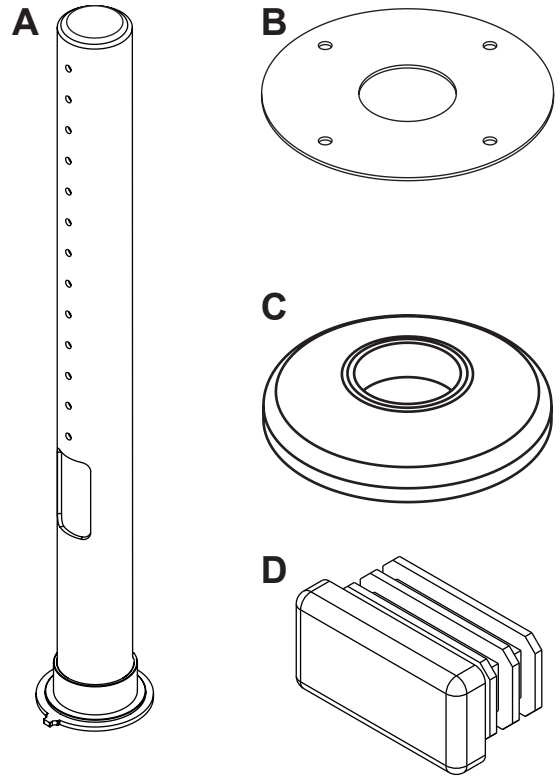

NOTE: Some parts may appear slightly different than illustrated.

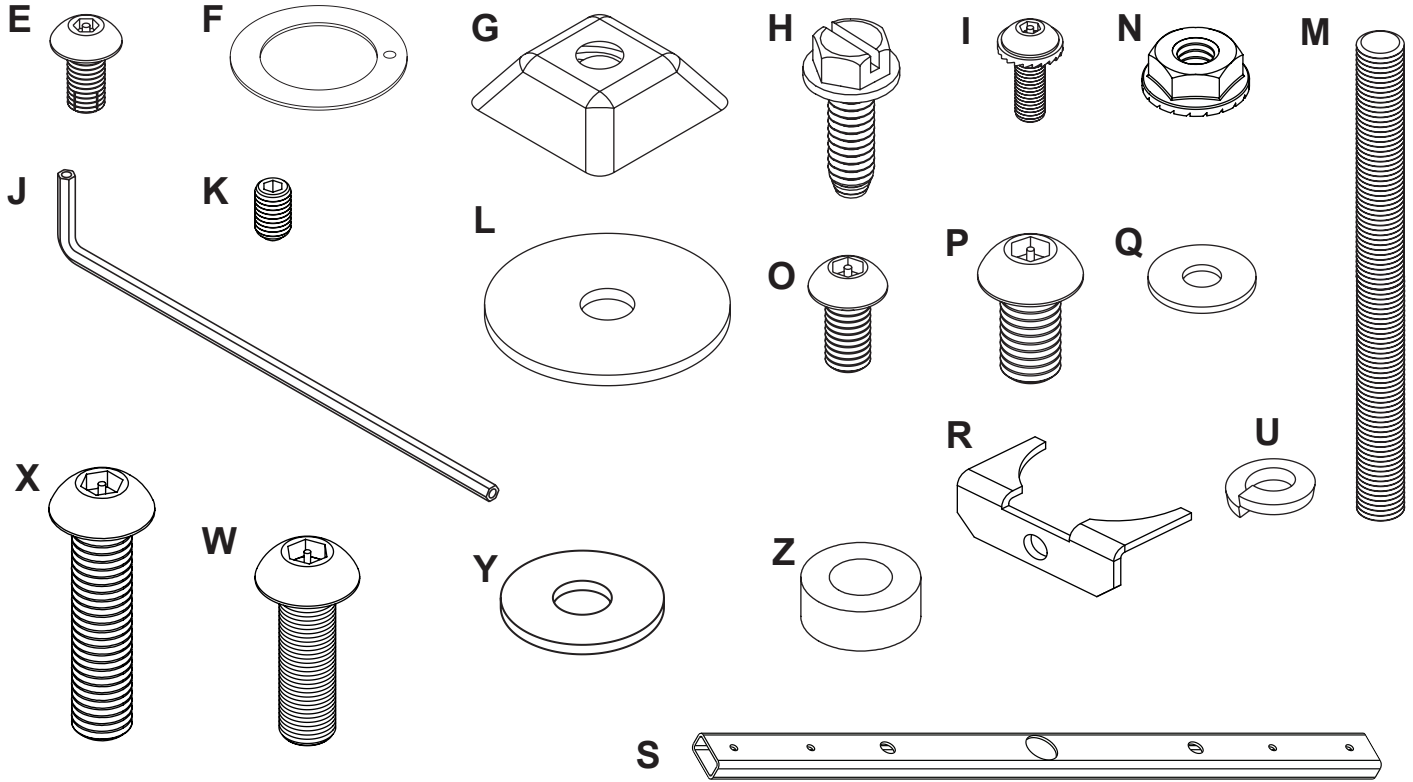

- | Tools Needed for Assembly | |
|---------------------------|----------------------|
| • electric drill | |
| • 5/8" open box wrench | |
| • 17/64" drill bit | |
| • 3/8" socket wrench | • 3/32" allen wrench |

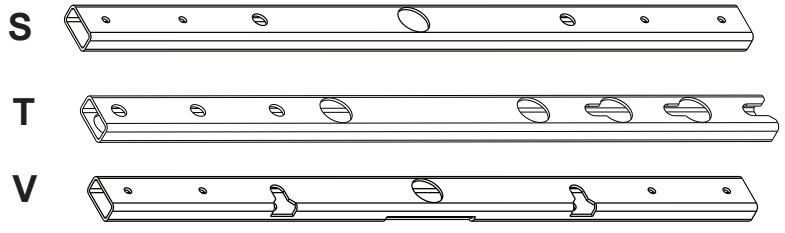

- 1** Use base backer plate (**B**) as a template to mark location of holes. Drill four holes using a 17/64" drill bit in a square formation. Drill a 2" to 3" cord management hole in the center of the square formation.

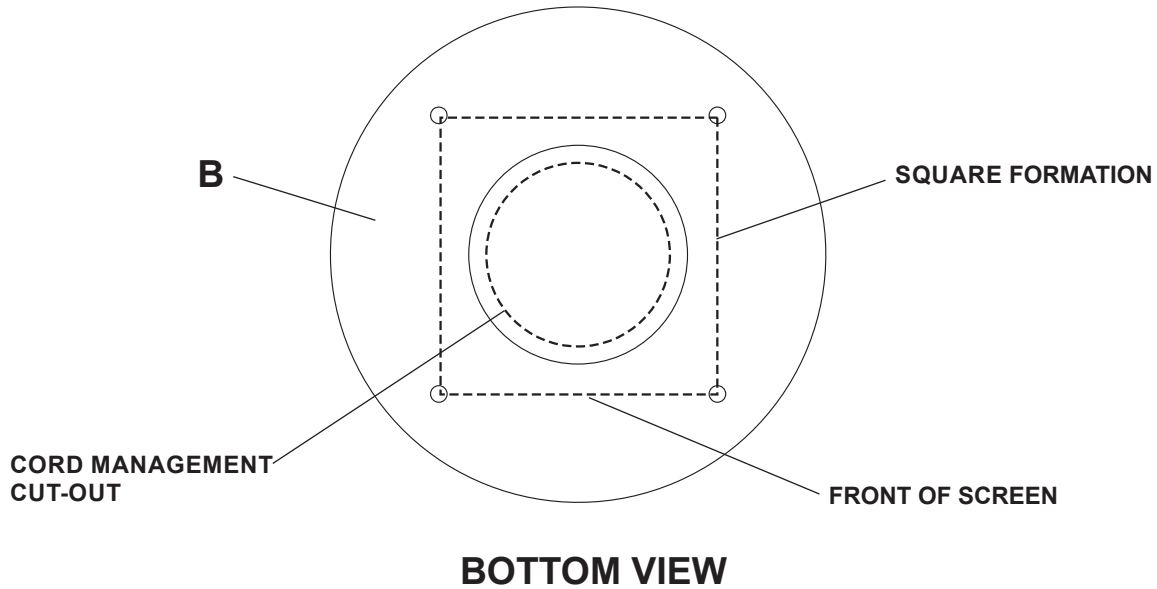

⚠ WARNING

- Wooden mounting surface requires a minimum of 3/4" thickness to hold screen securely.

- 2** Turn base (**C**) upside down and insert four threaded rods (**M**) into base (**C**), as shown below.

NOTE: Threaded rods must fasten a minimum of three turns.

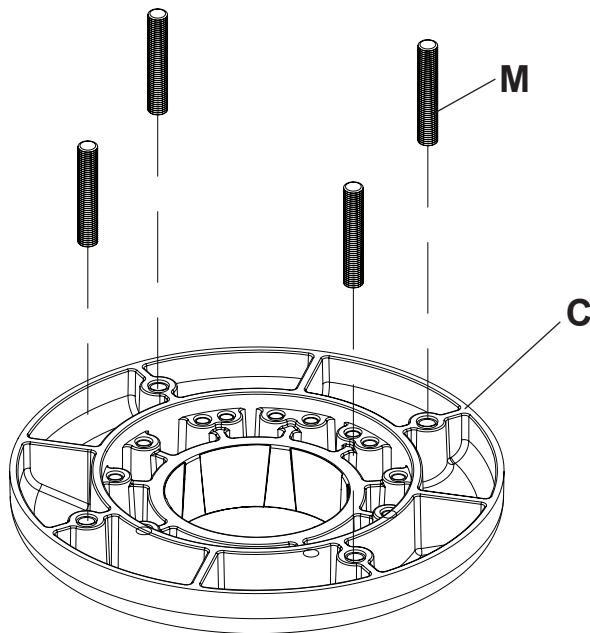

fig. 2.1

- 3** Turn base (**C**) upside down to insert support tube (**A**), and thrust washer (**F**) as shown below.

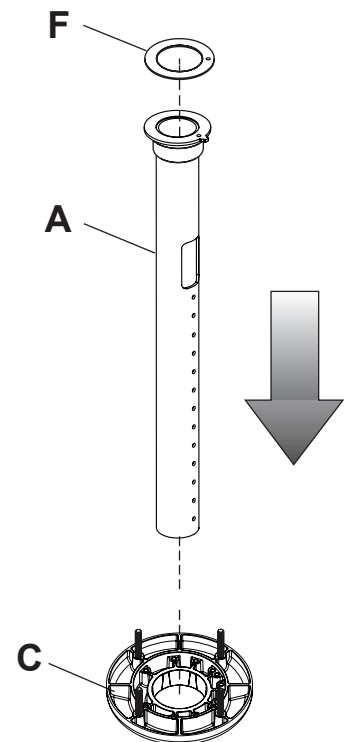

fig. 3.1

Swivel Restriction

- 4** Refer to fig. 4.1, 4.2, 4.3, and 4.4, to select the desired swivel degree. Using a 3/32" allen wrench, fasten two set screws (**K**) where indicated below to the outside of desired angle in steel base (**C**).

NOTE: Set screws (**K**) must be bottomed out into base.

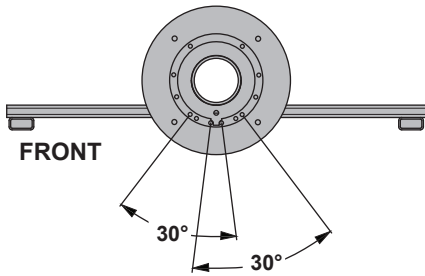

fig. 4.1

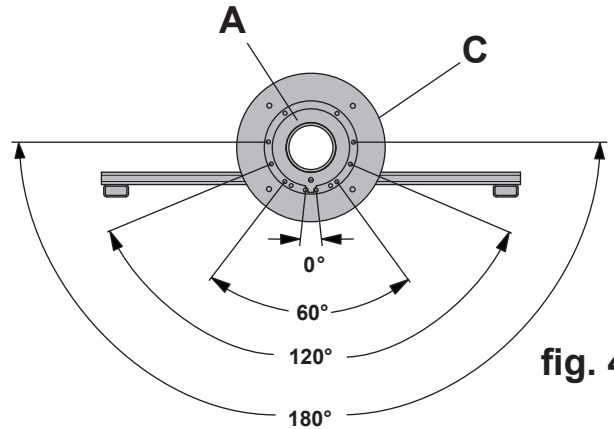

fig. 4.2

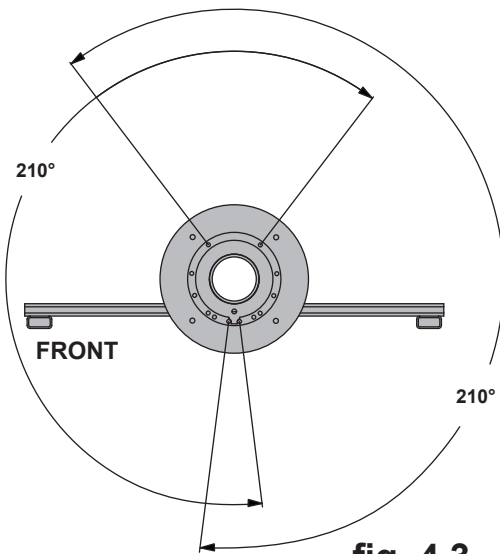

fig. 4.3

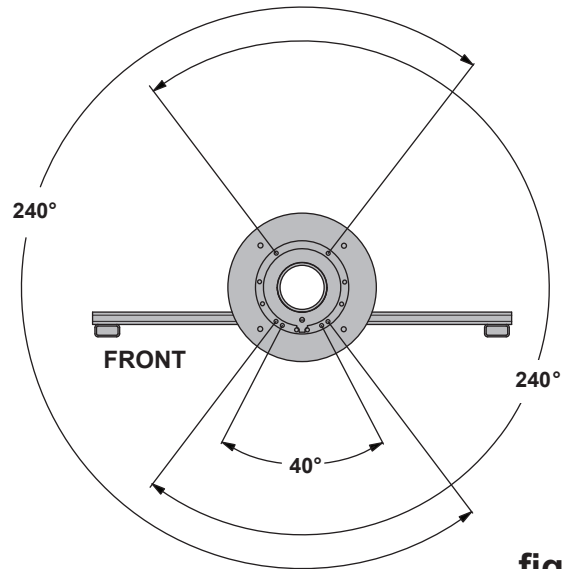

fig. 4.4

Mounting to Support Surface

▲ WARNING

- Make sure that the supporting surface will safely support the combined load of the equipment and all attached hardware and components.

CAUTION

- Installations to desktops that have a gap between two supporting boards are not acceptable mounting surfaces for the HP line of desktop swivel mounts.

Mounting using Non-Security Step 5 Page 5

Mounting using Security Slop Nuts (Optional) Step 7 Page 6

Mounting using Non-Security

- 5** Align backer plate (B) with threaded rods (M).
NOTE: Washer (F) must be centered.

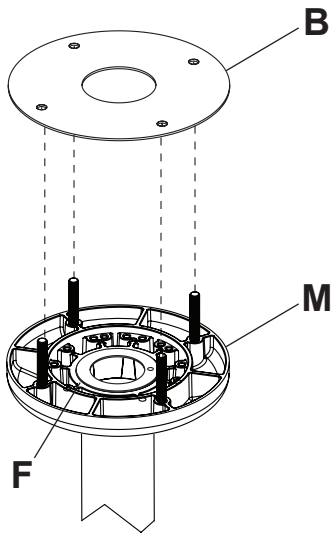

fig. 5.1

- 6** Align base assembly (step 5) with supporting surface and base (C) pattern facing the front as shown in Detail 1. Tighten four fender washers (L) with four lock nuts (N) in the sequenced pattern shown in Figure 6.1 with the 1/4 - 20 locknuts (N) at minimum flush with the bottom of the threaded rods (M).

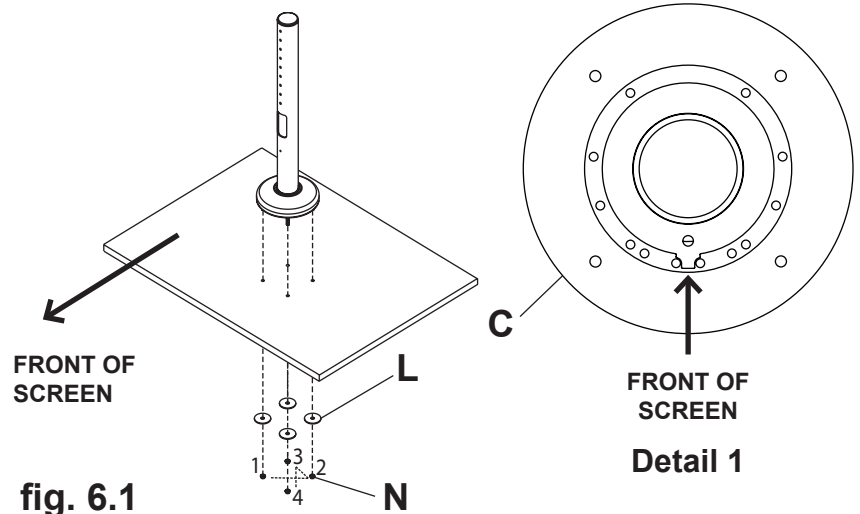

fig. 6.1

Mounting using Security Slope Nuts (Optional)

- 7** For added security replace two of the washers and locknuts with slope nuts.

Hand tighten slope nuts (**G**) onto two of the thread rods (**M**) until snug against bottom of table as shown in Detail 2.

Thread another slope nut (**G**) upside-down, about two turns from first slope nut (**G**) as shown in Detail 3.

NOTE: Avoid jamming both slope nuts (**G**) together, doing so may make it difficult to remove slope nut used for tightening.

Insert a 5/8" open box wrench between both slope nuts (**G**) and tighten as shown in Detail 4.

After top slope nut is secure remove bottom slope nut as shown in Detail 5.

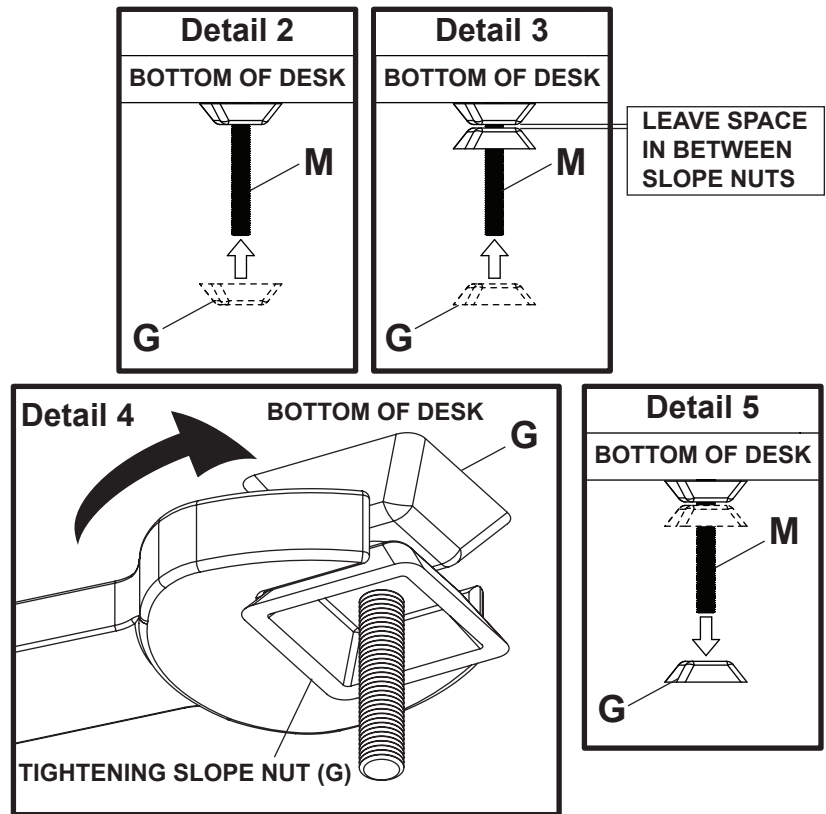

- 8** Press-in four tube caps (**D**) into lower horizontal rail (**S**) and upper horizontal rail (**V**) as shown below.

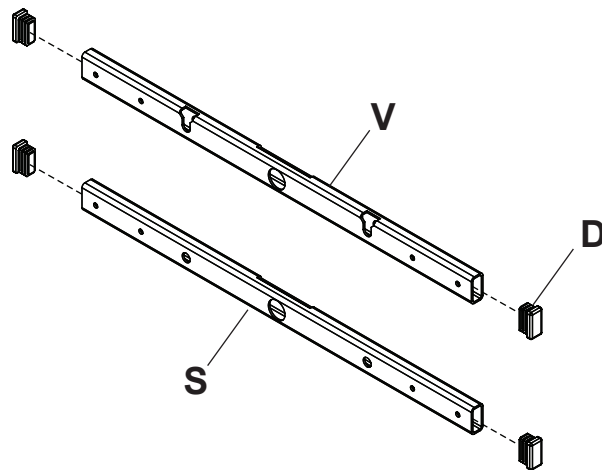

Mounting using Large Hole Pattern (300mm x 200mm or greater).....Start page 7

Mounting using Small Hole Pattern (200mm x 200mm or less)Skip to page 9

⚠ WARNING

- If screws don't get three complete turns in the screen inserts or if screws bottom out and bracket is still not tightly secured, damage may occur to screen or product may fail.

Mounting using Large Hole Pattern (300mm x 200mm or greater)

9 Fasten two vertical rails (**T**) to lower horizontal rail (**S**) and upper horizontal rail (**V**) in 300mm x 200mm, 300mm x 300mm, or 400mm x 400mm hole patterns using four M5 x 10mm socket pin Type-F screws (**E**) as shown below.

NOTE: Vertical rails (**T**) must be perpendicular to lower horizontal rail (**S**) and upper horizontal rail (**V**). Use a flat surface as guide while tightening.

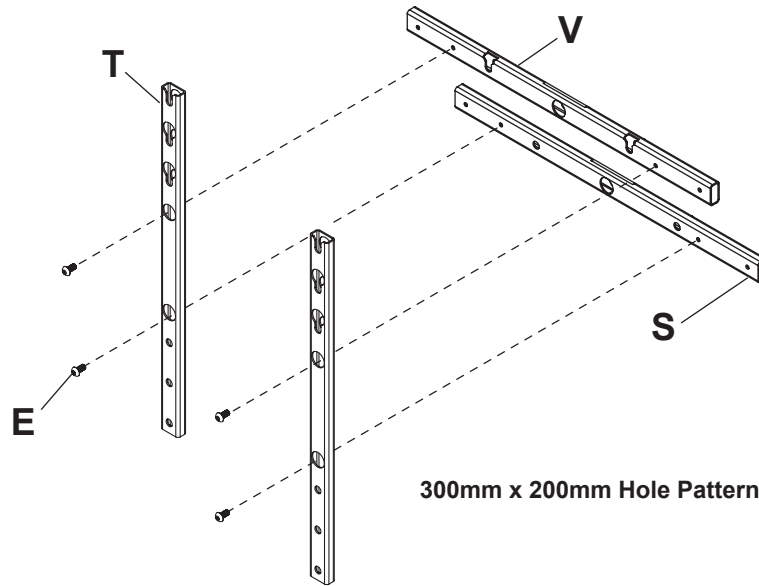

300mm x 200mm Hole Pattern

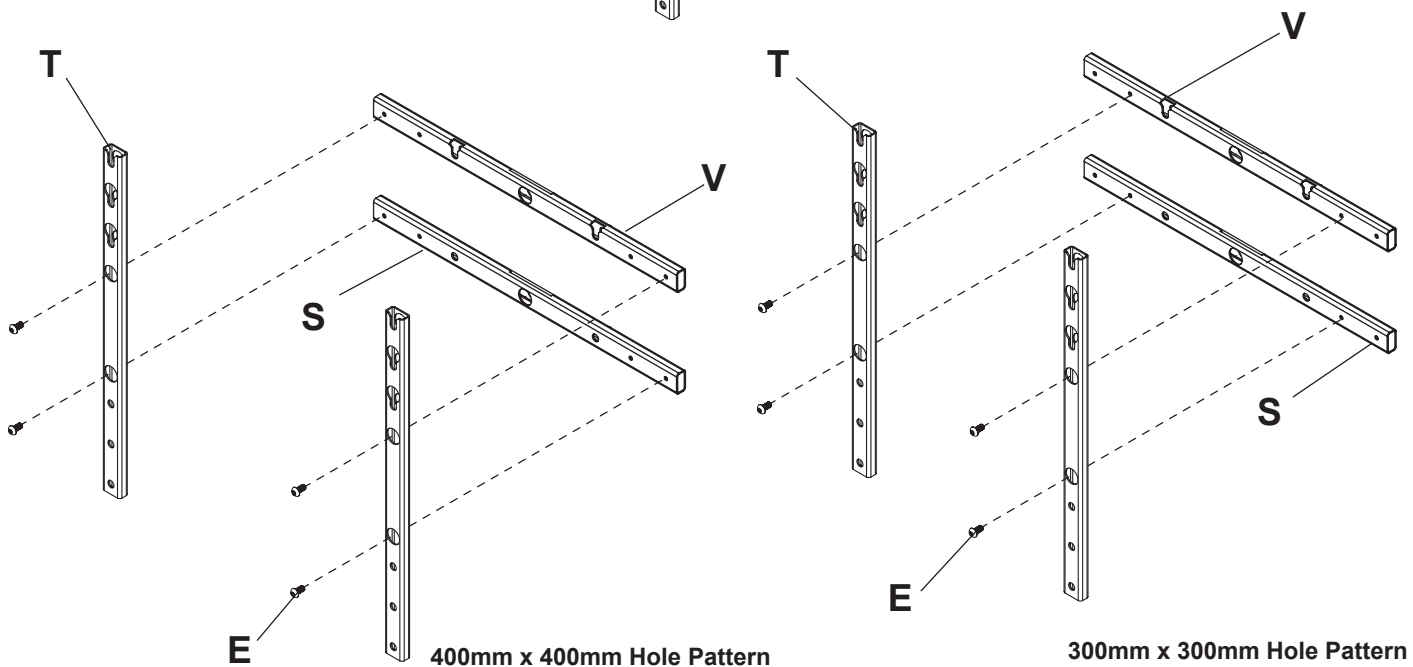

400mm x 400mm Hole Pattern

300mm x 300mm Hole Pattern

10 Position tube gussets (R) inside slots of lower horizontal rail (S) and upper horizontal rail (V) as shown below.

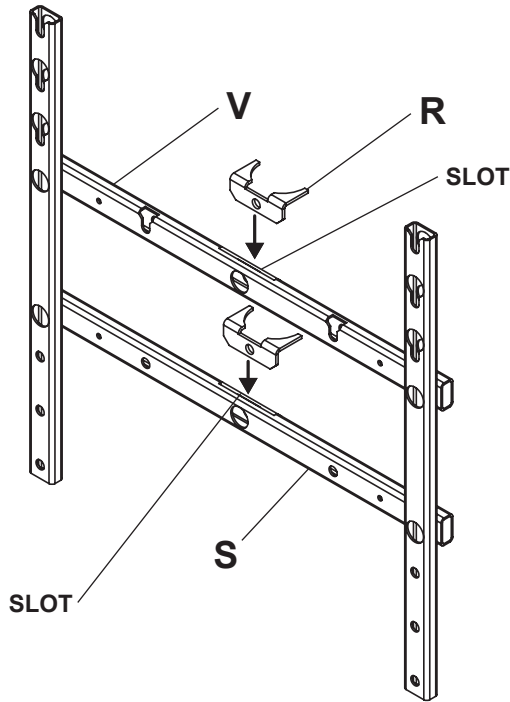

11 **NOTE:** Determine desired height of display prior to attaching lower horizontal rail (S) and upper horizontal rail (V) to support tube (A).

Attach tube gussets (R), lower adapter rail (S), and upper horizontal tube (V) onto support tube (A) using two 1/4-20 x 3/4" hex head screws (H) with two 1/4" split washers (U) as shown below.

TIP: Grip tube firmly while fastening screws using 3/8" socket drive. Drive screws into center of pole.

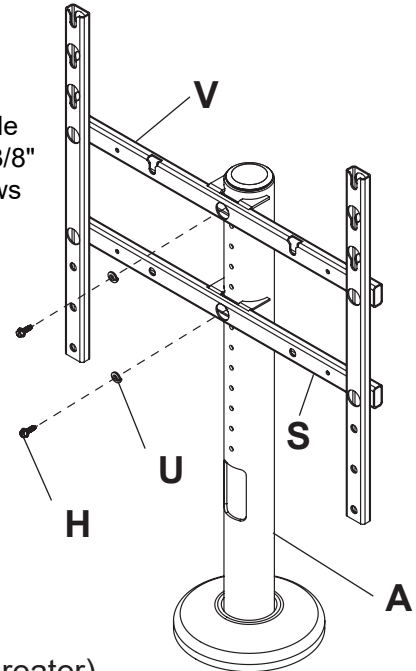

Mounting using Large Hole Pattern (300mm x 200mm or greater)

12 Fasten two socket pin screws (I, O, P, W, or X) into the top mounting holes behind the screen leaving 1/8" of exposed threads as shown below. Use of washer (Y) and spacer (Z) is optional. Hook exposed threads onto the top of vertical rails (T) and secure lower horizontal rail (S) using two socket pin screws (I, O, P, W, or X).

NOTE: When using socket pin screw (I), #10 flat washers (Q) are required.

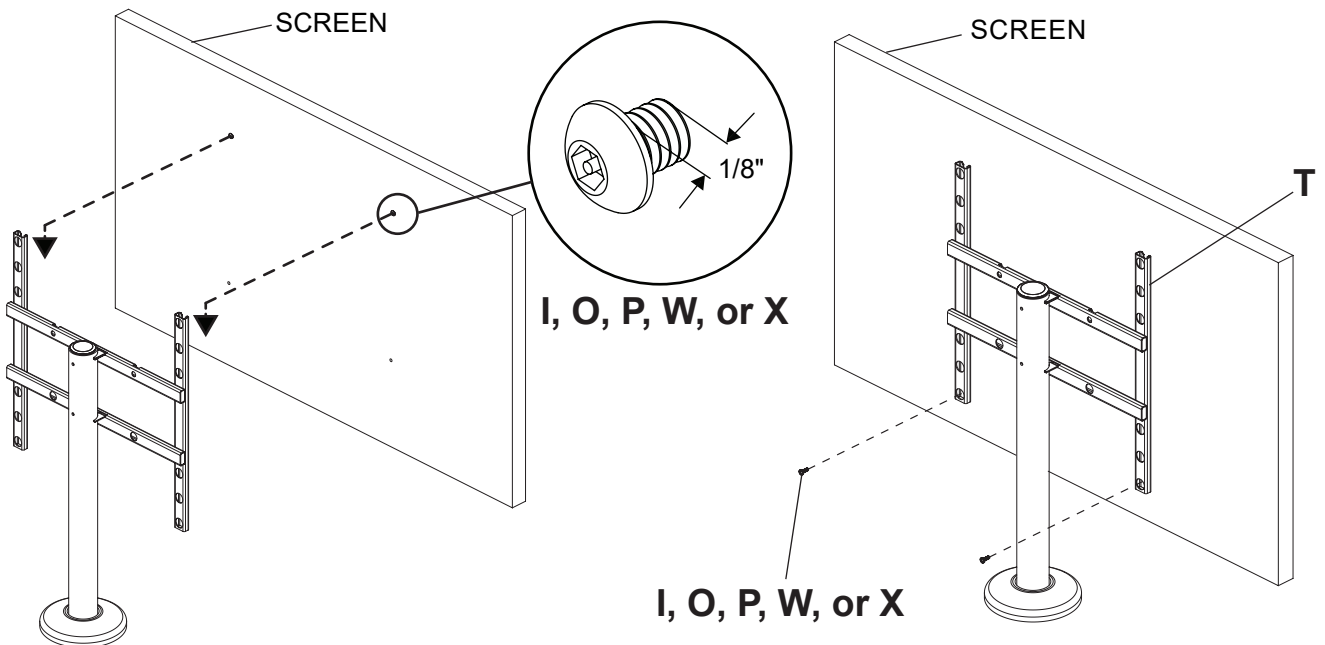

Mounting using Small Hole Pattern (200mm x 200mm or less)

9 Position tube gussets (**R**) inside slots in lower horizontal rail (**S**) and upper horizontal rail (**V**) as shown below.

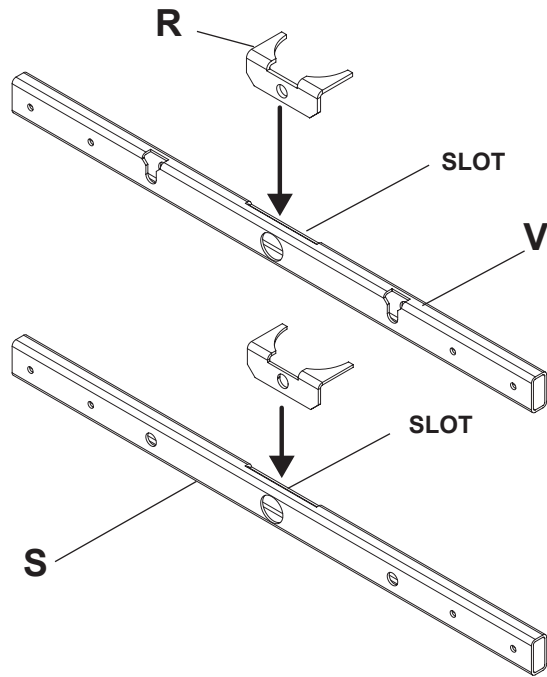

10 Attach tube gussets (**R**), lower horizontal rail (**S**), and upper horizontal rail (**V**) onto support tube (**A**) using two 1/4-20 x 3/4" hex head screws (**H**) with two 1/4" split washers (**U**) as shown below. **NOTE:** Use details 5 and 6 when determining the placement of adapter rail (**S**) and upper horizontal tube (**V**).

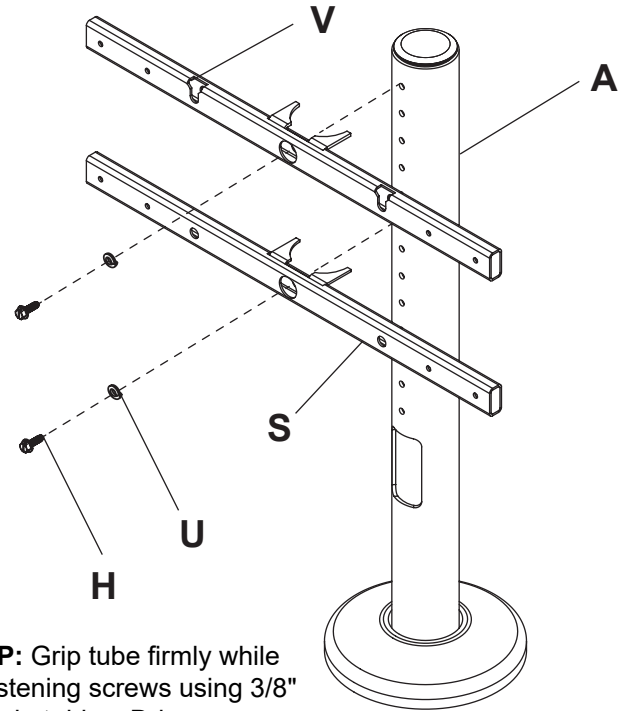

TIP: Grip tube firmly while fastening screws using 3/8" socket drive. Drive screws into center of pole.

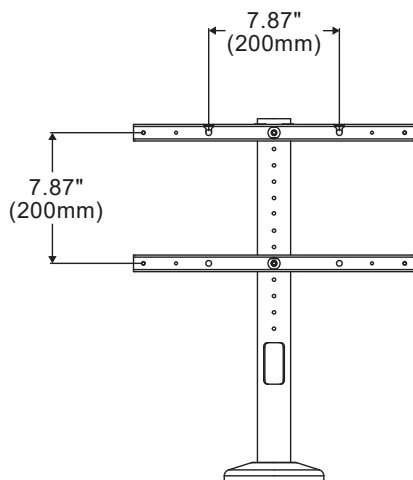

Detail 5

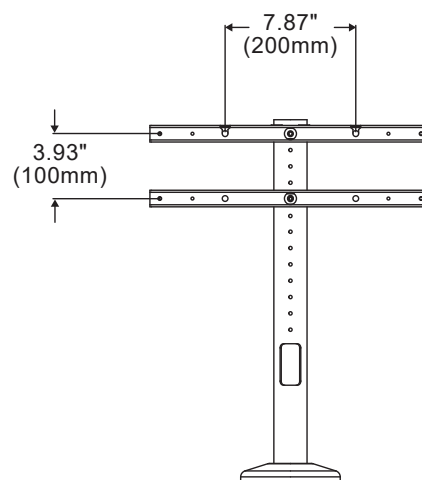

Detail 6

11 Fasten two socket pin screws (**I, O, P, W, or X**) into the top mounting holes behind the screen leaving 1/8" of exposed thread as shown below. Use of washer (**Y**) and spacer (**Z**) is optional. Hook the exposed threads onto the top of upper horizontal rail (**V**). Fasten lower horizontal rail (**S**) using two socket pin screws (**I, O, P, W, or X**).

NOTE: When using socket pin screw (**I**), #10 flat washers (**Q**) are required.

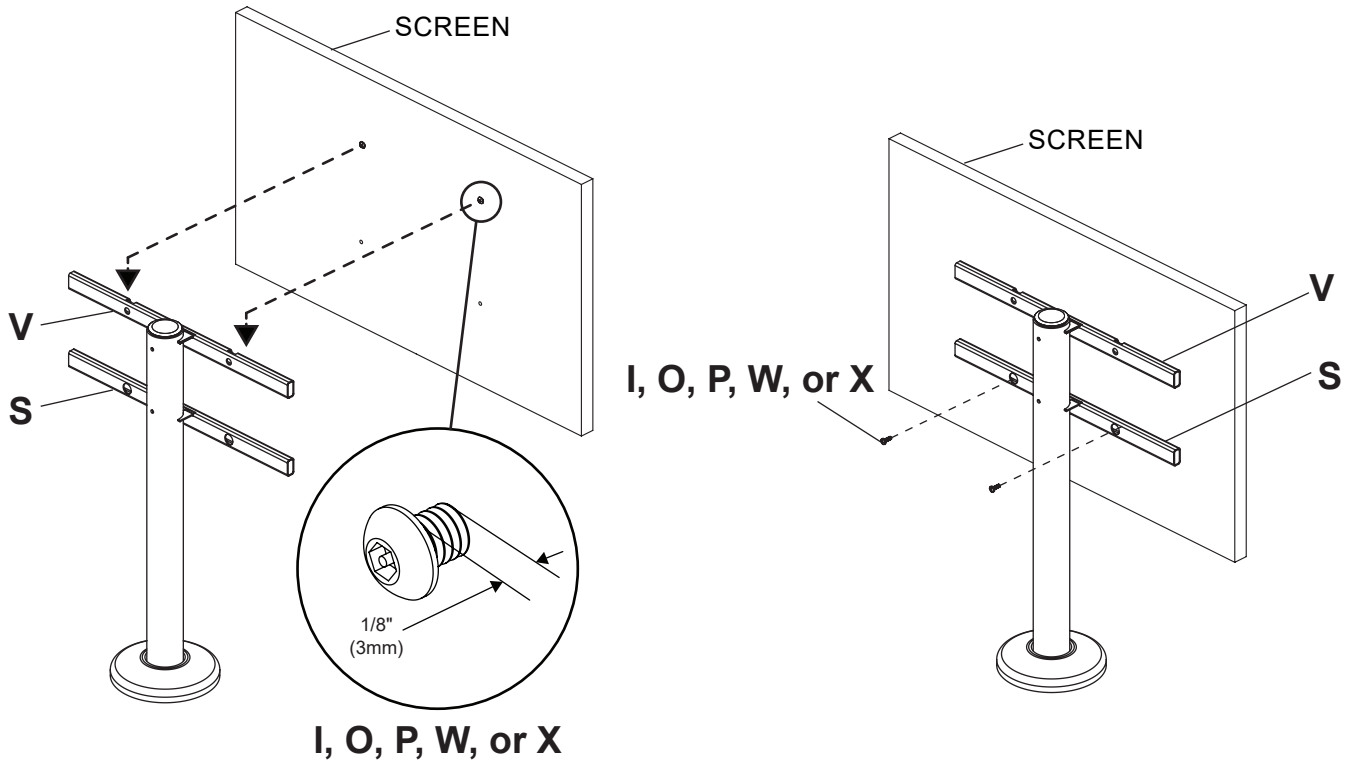

ENG	Warranty	ESP	Garantía	FRN	Garantie	DEU	Garantie	NEL	Garantie
ITL	Garanzia	ČEŠ	Záruka	SLK	Záruka	POR	Garantia	TÜR	Garanti

www.peerless-av.com/warranty



Peerless-AV
 2300 White Oak Circle
 Aurora, IL 60502
 Email: tech@peerlessmounts.com
 Ph: (800) 865-2112
 Fax: (800) 359-6500
www.peerless-av.com

© 2021, Peerless Industries, Inc.

Peerless-AV Europe
 Unit 3 Watford Interchange,
 Colonial Way, Watford, Herts,
 WD24 4WP, United Kingdom
 Customer Care
 44 (0) 1923 200 100
www.peerless-av.com

© 2021, Peerless Industries, Inc.

Peerless-AV América Latina
 Av. de las Industrias 413
 Parque Industrial Escobedo
 General Escobedo N.L., México 66062
 Servicio al Cliente
 01-800-849-65-77
www.peerless-av.com

© 2021, Peerless Industries, Inc.