

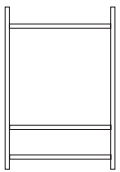

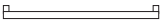

No.	PARTS		QTY
1		FRAME	2
2		CROSSBAR	2
3		CROSSBAR WITH THREADED INSERT	2
4		CASTER	4
5		DRAWER	2
6		WRENCH	1

**CAUTION:** To protect finish and prevent damaging frame, cover joints with cloth before tapping with mallet.



FRAMES FACING INWARD WITH THREADED INSERTS ON THE BOTTOM

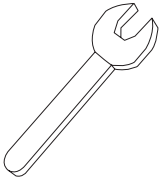
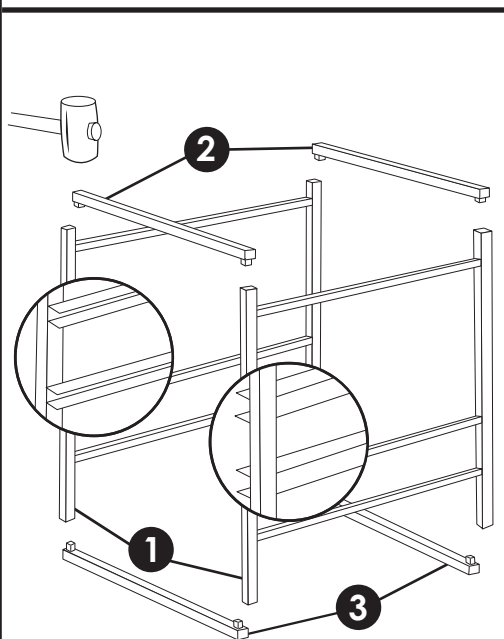
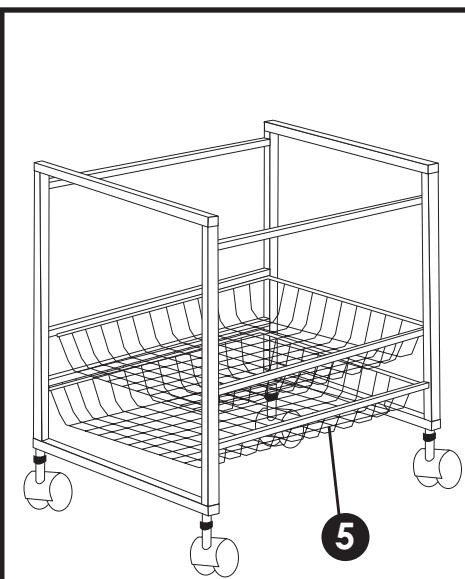
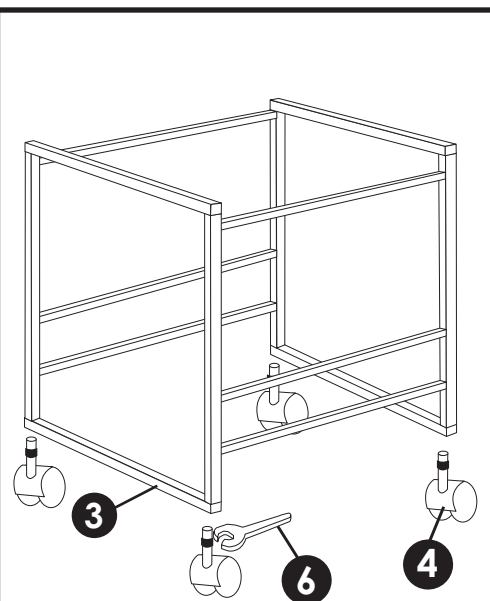

### STEP 1

Position frames (No. 1) with drawer slides facing each other as shown, positioning the shorter posts on top. Install cross bars (No. 2) into the top of frame. Tap with mallet to attach fasteners. Turn frame upside down and install cross bars (No. 3) into the bottom of frame. Tap with mallet to attach fasteners.

### STEP 2

To assemble the casters to the frame, use wrench (part No. 6) to screw casters (Part No. 4) to the bottom of the cross bar (Part No. 3).

### STEP 3

Slide each drawer (Part No. 5) into frame runner slots. Your file and drawer organizer is now ready for use!

**WARNING:** Weight limit of 40 lbs.