

PARTS LIST

No.	DESCRIPTION	QTY.	PART NO.
Common Hardware			
①	Tape	2	9517
②	Plastic Trim Strip	2	3094-63
③	Velcro (Loop)	6	9516
④	Velcro (Hook)	6	9515
⑤	Reinforcement Board	4	3094-65
Model 3092			
⑥	Shell	2	3092-01
⑦	Tubes	36	3092-30
Model 3093			
⑥	Shell	2	3092-01
⑦	Tubes	64	3093-30
Model 3094			
⑥	Shell	2	3094-01
⑦	Tubes	36	3094-30
Model 3095			
⑥	Shell	2	3094-01
⑦	Tubes	64	3095-30
Model 3096			
⑥	Shell	2	3096-01
⑦	Tubes	36	3096-30
Model 3097			
⑥	Shell	2	3096-01
⑦	Tubes	64	3097-30

For questions or concerns, please call
Safco Consumer Hot Line 1-800-664-0042
 available Monday-Friday 8:00 AM to 4:30 PM (Central Time)
 (English-speaking operators)

ASSEMBLY INSTRUCTIONS

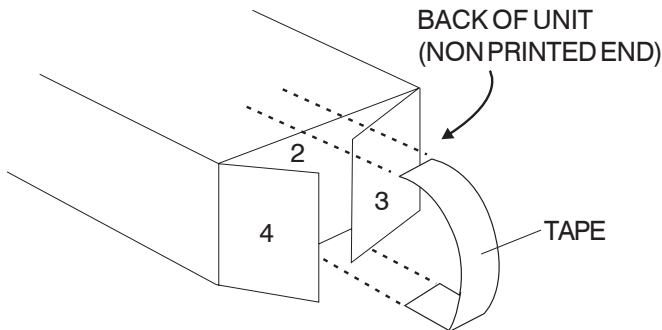

1 To assemble outer shell: Square up unit. Fold in end flaps 1, 2, 3 and 4 in that order. Moisten tape and apply to seam.

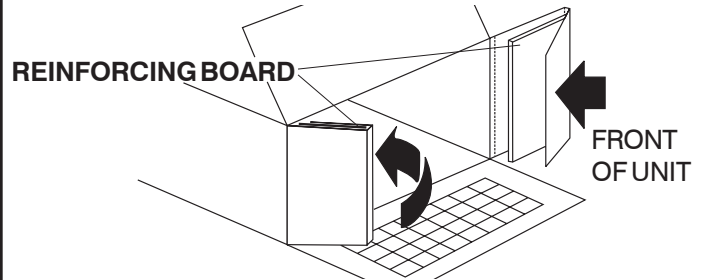

2 Installing reinforcing board: Fold front side flaps around reinforcement boards. Fold sandwiched boards into unit.

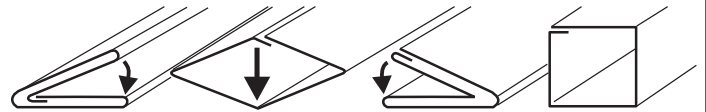

4a On flat surface: Back fold tubes in half (in both directions). Tubes must be perfectly square before insertion into shell.

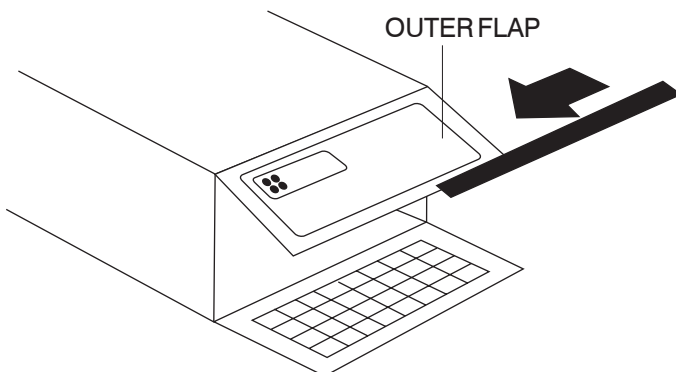

3 Installing plastic trim strip: Slide plastic trim strip over front edge of outer flap as shown.

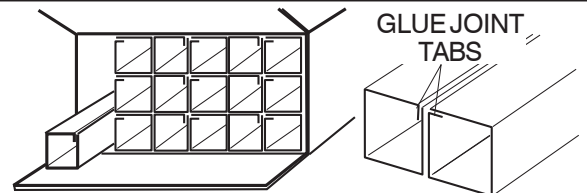

4b CAUTION: Tube adjustment tabs must be toward back of unit...see step 4C before proceeding.
Installing tubes into shell: Lay shell on flat surface. Insert tubes across bottom, with glue joints rotated as shown. Repeat on remaining rows.

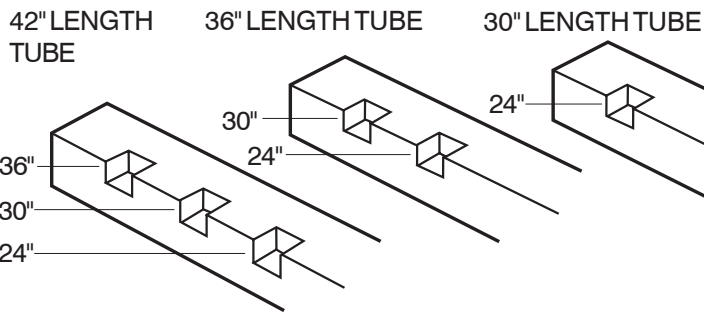

4c Special Feature: **Roll file tube length adjustment:** Depth of tube may be changed by pressing in desired depth tab on each side of tube. (Tube end with adjustment tabs must be toward back of shell)

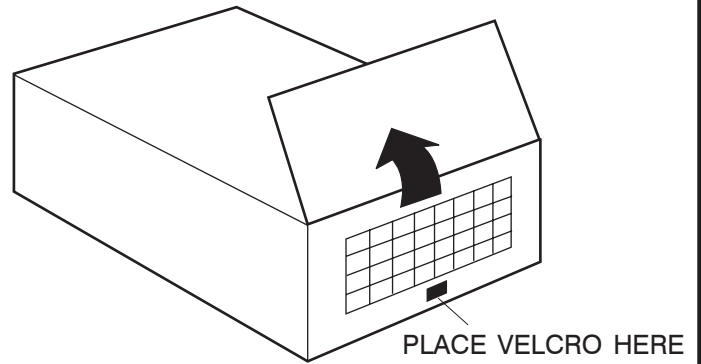

5 To apply velcro hook fastener: Start with units in this position. Peel backing off one side of velcro sandwich and stick on square of inner flap.

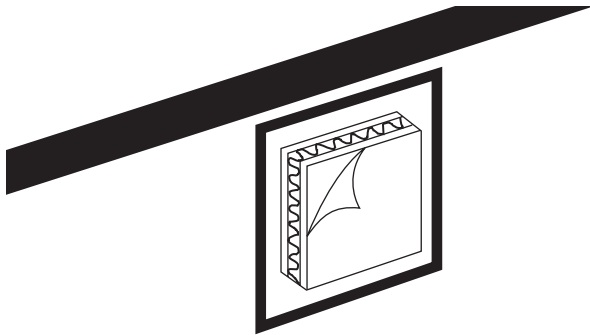

6 With velcro sandwich mounted to unit, peel off remaining backing. Do not separate velcro halves.

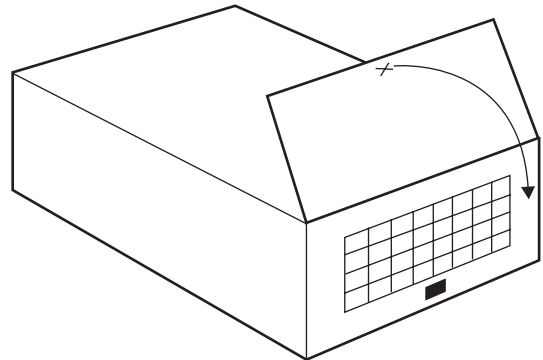

7 Close lid on exposed sticky surface. Rub firmly. Peel apart and rub both sides.

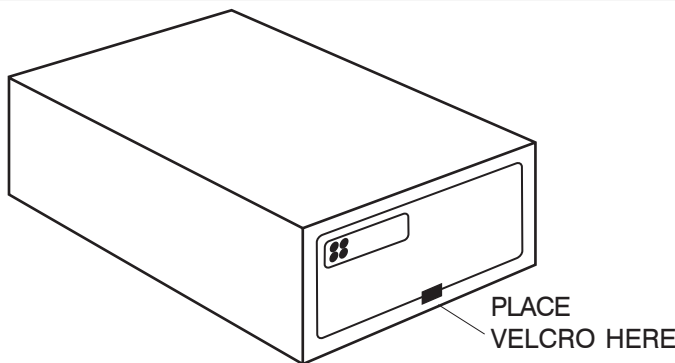

8 To hold door open: Peel backing off one side of velcro sandwich. Stick in square of outer flap and rub down.



READ THRU
STEP 11
BEFORE
CONTINUING
ASSEMBLY

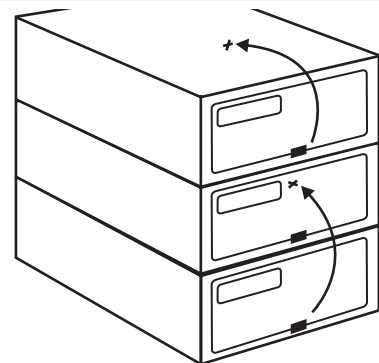

9 Recommended position: To hold door open, peel off other half of velcro backing from step 8 and open door to top of unit (A) or unit above (B).

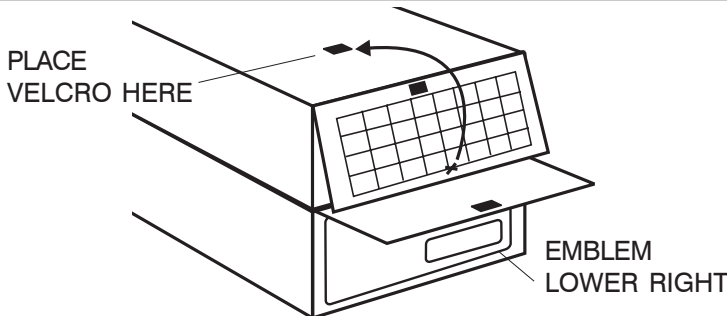

10 Optional position: (Turn unit over). To hold door open (no units on top) peel backing off one side of velcro sandwich and place in square on top of unit, rub down. Peel off other half of velcro backing and open inner flap to top, rub down and separate.

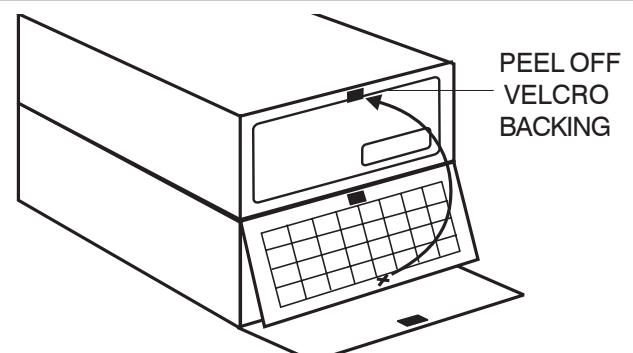

11 To hold door open when units are stacked: Peel off velcro backing from square of upper unit. Open inner flap and press onto exposed square, rub down and separate.