

Memory Configurator

Lenovo ThinkStation P8



Table of Contents

Overview	3
Section 1 – Platform Memory Architecture	3
Section 2 – Physical Memory Layout	4
Section 3 – Memory Slot Fill Order.....	6
Section 4 – Memory Configuration Notes.....	7
Revision History	8



Overview

ThinkStation P8 is a single processor, 39L tower added to the Lenovo workstation portfolio in early 2024. This document describes the P8 memory subsystem architecture and provides configuration guidelines to help you obtain optimal system performance.

Section 1 – Platform Memory Architecture

ThinkStation P8 is powered by the AMD Ryzen Threadripper Pro 7000 WX-series CPUs and supports DDR5 memory. All P8 models have the following memory specifications:

Channels	8 channels, DDR5, 1 DIMM per Channel (DPC)
Slots	8 slots, supporting DDR 4800 MHz speed
Controllers	4 memory controllers
Type	DDR5-4800 ECC RDIMM DDR5-4800 ECC 3DS-RDIMM
Speed	Up to 4800MHz
Qualified DIMM Sizes	16GB, 32GB, 64GB RDIMM / 128GB 3DS-RDIMM
Max System Memory	Up to 1TB maximum (8x 128GB 3DS-RDIMM)

**Note: Max memory is based on testing results with current Lenovo memory offerings*

Section 2 – Physical Memory Layout

The diagram below (*Figure 1*) shows a high level representation of the physical memory slot layout on the P8 motherboard.

Figure 1 – DIMM slot layout

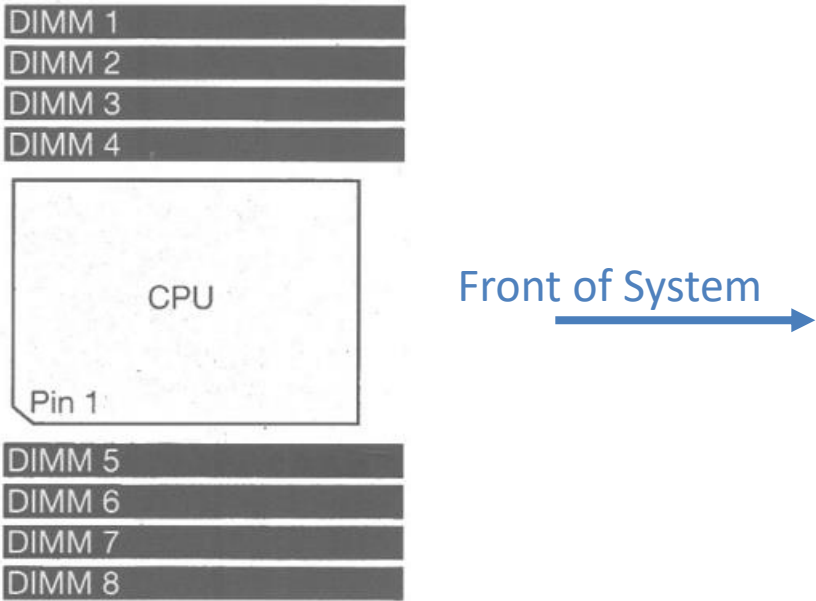

Every P8 ships with an active cooling system for each memory bank. The DIMM cooling system consists of a 40mm fan/baffle kit that fully surrounds the memory bank and latches into place on the motherboard. The fans are then plugged into 8-pin headers located toward the rear of the system. A picture of the memory cooling system is shown in *Figure 2* below.

Figure 2 – DIMM cooling system

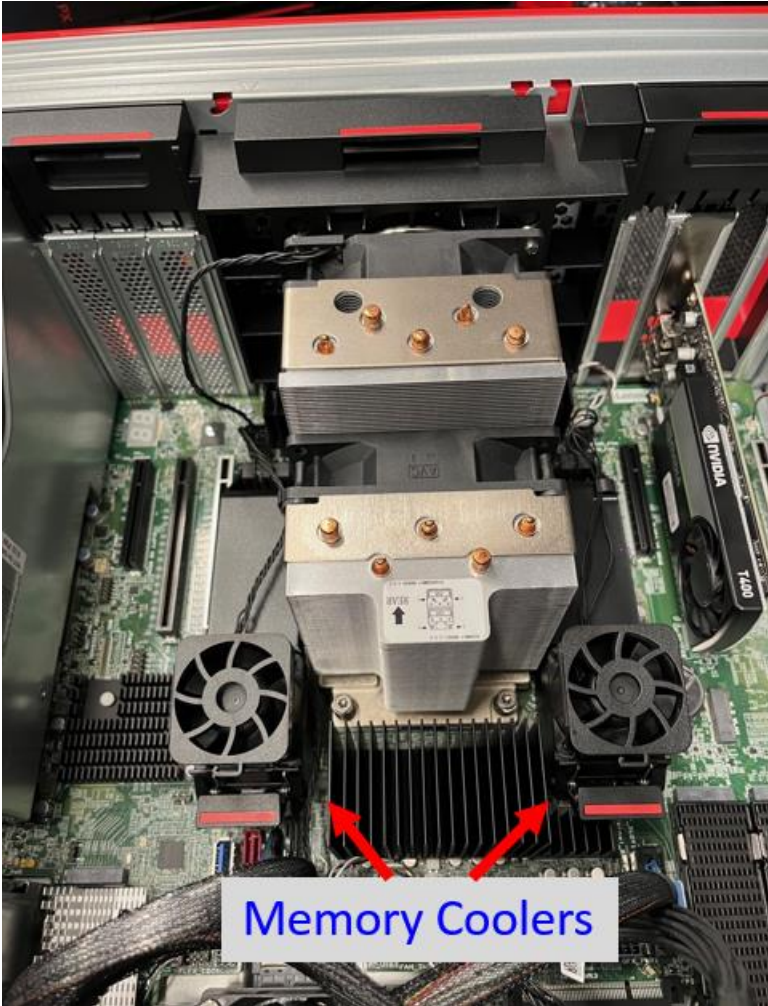

Section 3 – Memory Slot Fill Order

The best way to optimize P8 system memory performance is to populate all memory DIMM slots with the same size and type of memory. However, this may not be practical for your particular implementation. Lenovo recommends following the slot fill order rules below to ensure optimal memory performance for all possible memory configurations.

Table 1 – Memory Slot Install Order

# of DIMMs	DIMM Slot Install Order
1 DIMM	DIMM 4
2 DIMMs	DIMM 4, 5
3 DIMMs	Not Supported ¹
4 DIMMs	DIMM 4, 5, 2, 7
5 DIMMs	Not Supported ¹
6 DIMMs	DIMM 4, 5, 2, 7, 3, 6
7 DIMMs	Not Supported ¹
8 DIMMs	DIMM 4, 5, 2, 7, 3, 6, 1, 8

¹ Configurations with an odd total number of DIMMs greater than 1 can adversely affect performance and are therefore not supported.

Section 4 – Memory Configuration Notes

The following guidelines are recommended by Lenovo for obtaining the best memory bandwidth from the ThinkStation P8 platform.

- Single Rank and Dual Rank DIMMs cannot be mixed
- 3DS-RDIMMs cannot be mixed with RDIMMs
- ECC and non-ECC UDIMMs are not supported
- DIMMs should be of the same type and capacity
- Lenovo recommends populating every DIMM slot for optimal memory performance

Revision History

Version	Date	Author	Changes/Updates
1.0	2/1/2024	Jim P	Initial Version