



Maintenance and Service Guide

SUMMARY

This guide provides information about spare parts, removal and replacement of parts, security, backing up, and more.

© Copyright 2021 HP Development Company, L.P.

AMD is a trademark of Advanced Micro Devices, Inc. Bluetooth is a trademark owned by its proprietor and used by HP Inc. under license. Chrome, Chromebook, Chrome OS, Google, and Google Drive are trademarks of Google LLC. Intel and vPro are trademarks of Intel Corporation or its subsidiaries in the U.S. and/or other countries. Qualcomm is a trademark of Qualcomm Incorporated, registered in the United States and other countries, used with permission. SDHC, SDXC, and microSD are trademarks or registered trademarks of SD-3C LLC. USB Type-C and USB-C are registered trademarks of USB Implementers Forum. DisplayPort™ and the DisplayPort™ logo are trademarks owned by the Video Electronics Standards Association (VESA®) in the United States and other countries.

The information contained herein is subject to change without notice. The only warranties for HP products and services are set forth in the express warranty statements accompanying such products and services. Nothing herein should be construed as constituting an additional warranty. HP shall not be liable for technical or editorial errors or omissions contained herein.

First Edition: January 2021

Document Part Number: M42846-001

Product notice

This guide describes features that are common to most models. Some features may not be available on your computer.

To access the latest user guides, go to <http://www.hp.com/support>, and follow the instructions to find your product. Then select

Manuals.

Software terms

By installing, copying, downloading, or otherwise using any software product preinstalled on this computer, you agree to be bound by the terms of the HP End User License Agreement (EULA). If you do not accept these license terms, your sole remedy is to return the entire unused product (hardware and software) within 14 days for a full refund subject to the refund policy of your seller.

For any further information or to request a full refund of the price of the computer, please contact your seller.

Safety warning notice

Reduce the possibility of heat-related injuries or of overheating the computer by following the practices described.

 **WARNING!** To reduce the possibility of heat-related injuries or of overheating the computer, do not place the computer directly on your lap or obstruct the computer air vents. Use the computer only on a hard, flat surface. Do not allow another hard surface, such as an adjoining optional printer, or a soft surface, such as pillows or rugs or clothing, to block airflow. Also, do not allow the AC adapter to come into contact with the skin or a soft surface, such as pillows or rugs or clothing, during operation. The computer and the AC adapter comply with the user-accessible surface temperature limits defined by applicable safety standards.

Table of contents

1 Product description	1
2 Components	3
Right	3
Left	4
Display	5
Touchpad	6
Special keys	7
Bottom	8
3 Illustrated parts catalog	9
Computer major components	9
Display assembly subcomponents	13
Cables	15
Miscellaneous parts	16
4 Removal and replacement procedures preliminary requirements	17
Tools required	17
Service considerations	18
Plastic parts	18
Cables and connectors	18
Drive handling	18
Electrostatic discharge information	19
Generating static electricity	19
Preventing electrostatic damage to equipment	20
Personal grounding methods and equipment	20
Grounding the work area	20
Recommended materials and equipment	21
Cleaning your computer	22
Enabling HP Easy Clean (select products only)	22
Removing dirt and debris from your computer	22

Cleaning your computer with a disinfectant	23
Caring for wood veneer (select products only)	24
Packaging and transporting guidelines	24
Accessing support information	24
5 Removal and replacement procedures for authorized service provider parts	27
Component replacement procedures	28
Preparation for disassembly	28
Top cover/keyboard	28
Touchpad cable	31
Touchpad	32
Speakers	33
Battery	34
Sensor board cable	35
Sensor board	36
System board	37
Heat sink	39
29.5 cm (11.6 in) display assembly	40
6 Backing up, resetting, and recovering	47
Backing up	47
Resetting	47
Recovering	48
Installing the Chromebook Recovery Utility	48
Creating recovery media	48
Recovering the Chrome operating system	48
Setting up your computer after a reset or recovery	48
Erase and reformat the recovery media	48
7 Specifications	51
Computer specifications	51
29.5 cm (11.6 in) display specifications	52
8 Statement of memory volatility	53
Current BIOS steps	53
Nonvolatile memory usage	55
Questions and answers	57
Using HP Sure Start (select products only)	59

9 Power cord set requirements	61
Requirements for all countries	61
Requirements for specific countries and regions	61
10 Recycling	65
Index	67

1 Product description

This table provides detailed product information.

Table 1-1 Product components and their descriptions

Category	Description
Product Name	HP Chromebook™ 11MK G9 Education Edition
Processors	Mediatek Arm Cortex-A MT8183 2.00 GHz (8 cores)
Chipset	Mediatek integrated soldered-on-circuit (SoC)
Display	29.5 cm (11.6 in), liquid crystal display (LCD), high definition (HD) (1366 × 768), antiglare, white light-emitting diode (WLED), UWVA, 50% CG, eDP 1.2 without PSR, slim touchscreen display panel, 220 nits 29.5 cm (11.6 in), LCD, HD (1366 × 768), antiglare, WLED, UWVA, 50% CG, eDP, slim non-touchscreen display panel, 220 nits 29.5 cm (11.6 in), LCD, HD (1366 × 768), antiglare, WLED, SVA, 45% CG, eDP, slim non-touchscreen display panel, 220 nits
Memory	On-board (nonupgradeable) system memory supporting 8 GB or 4 GB Support for 4266 LPDDR4X 0.6v IC FBGA200 system memory
Media card reader	microSD™ media reader slot Supports microSD, SDHC™, SDXC™ Push-push insertion/removal On-board (nonupgradeable) eMMC 64 GB MO-276 MMC v5.0
Multimedia card	On-board (nonupgradeable) embedded MultiMedia Controller (eMMC) 64 GB MO-276 MMC v5.0
Networking	Qualcomm® ac 2×2 + Bluetooth® 4.2 MU-MIMO non-vPro® WW with 2 antennas (QCA6174A-3)
Storage	On-board (nonupgradeable) eMMC 32 GB MO-276 MMC v5.0
Audio and video	Dual speakers Integrated HP HD camera: USB 2.0 720p by 30 frames per second
Ports	Audio-out (headphone)/audio-in (microphone) combo jack USB 2.0 Type-A USB 2.0 Type-C
Keyboard/pointing devices	Keyboard: Integrated, spill-resistant keyboard in jet black and nautical teal finishes Touchpad:

Table 1-1 Product components and their descriptions (continued)

Category	Description
	Touchpad with image sensor
	Multitouch gestures enabled
	Precision touchpad support
	Support for Modern Trackpad Gestures
	Taps enabled as default
Power requirements	Battery: 2 cell, 47 WHr, HP Long Life
	Smart AC adapter: 45 W, non-PFC, standard, USB Type-C, straight
	Power cord: C5, 1.0 m (3.3 ft)
Security	H1 secure microcontroller
	Nano security cable slot
Operating system	Google® Chrome™ 64
Serviceability	End user replaceable part: AC adapter

2 Components

This is the Components chapter from the user guide.

Right

Use the illustration and table to identify the components on the right side of the computer.

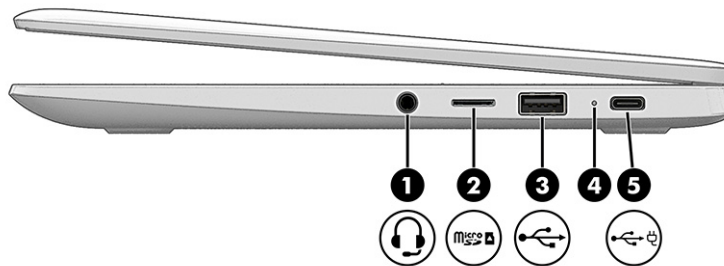

Table 2-1 Right-side components and their descriptions





Component	Description
(1)  Audio-out (headphone)/Audio-in (microphone) combo jack	Connects optional powered stereo speakers, headphones, earbuds, a headset, or a television audio cable. Also connects an optional headset microphone. This jack does not support optional standalone microphones. WARNING! To reduce the risk of personal injury, adjust the volume before putting on headphones, earbuds, or a headset. For additional safety information, see the <i>Regulatory, Safety, and Environmental Notices</i> . NOTE: When a device is connected to the jack, the computer speakers are disabled.

Table 2-1 Right-side components and their descriptions (continued)

Component	Description
(2)  microSD™ memory card reader	Reads optional memory cards that store, manage, share, or access information. To insert a card: <ol style="list-style-type: none"> 1. Hold the card label-side up, with the connectors facing the computer. 2. Insert the card into the memory card reader, and then press in on the card until it is firmly seated. To remove a card: ▲ Press in on the card, and then remove it from the memory card reader.
(3)  USB port	Connects a USB device, provides data transfer, and (for select products) charges small devices (such as a smartphone) when the computer is on or in Sleep mode. NOTE: Use a standard USB Type-A charging cable or cable adapter (purchased separately) when charging a small external device.
(4) AC adapter and battery light	<ul style="list-style-type: none"> • White: The AC adapter is connected and the battery is fully charged. • Amber: The AC adapter is connected and the battery is charging. • Blinking amber: The battery has an error. • Off: The battery is not charging.
(5)  USB Type-C® power connector and port	Connects an AC adapter that has a USB Type-C connector, supplying power to the computer and, if needed, charging the computer battery. – and – Connects a USB device, provides data transfer, and (for select products) charges small devices (such as smartphone) when the computer is on or in Sleep mode. NOTE: Use a standard USB Type-C charging cable or cable adapter (purchased separately) when charging a small external device. – and – Connects a display device that has a USB Type-C connector, providing DisplayPort™ output.

Left

Use the illustration and table to identify the components on the left side of the computer.

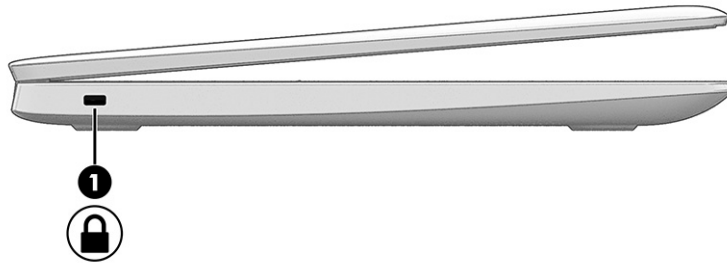

Table 2-2 Left-side components and their descriptions

Component	Description
(1) Security cable slot	Attaches an optional security cable to the computer. NOTE: The security cable is designed to act as a deterrent, but it might not prevent the computer from being mishandled or stolen.

Display

Use the illustration and table to identify the components on the display.

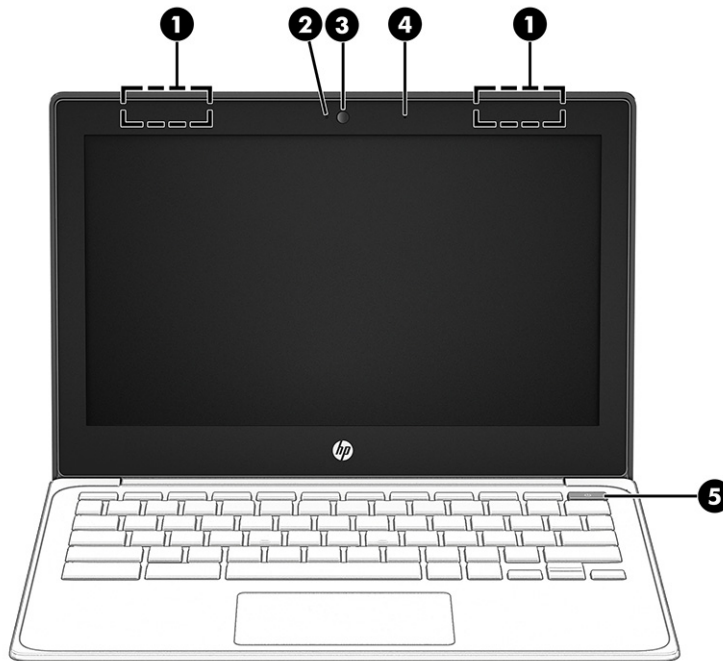

Table 2-3 Display components and their descriptions

Component	Description
(1) WLAN antennas*	Send and receive wireless signals to communicate with wireless local area networks (WLANs).

Table 2-3 Display components and their descriptions (continued)

Component	Description
(2) Camera light	On (white): The camera is in use. On (amber): The camera is turned off by the switch. Off: The camera is turned off by the software.
(3) Camera	Allows you to video chat, record video, and record still images. NOTE: Camera functions vary depending on the camera hardware and software installed on your product.
(4) Internal microphones	Record sound.
(5) Power key	<ul style="list-style-type: none">• When the computer is off, press the key briefly to turn on the computer.• When the computer is on, press the key briefly to initiate Sleep.• When the computer is in the Sleep state, press the key briefly to exit Sleep (select products only).• When the computer is in Hibernation, press the key briefly to exit Hibernation. IMPORTANT: Pressing and holding down the power key results in the loss of unsaved information. If the computer has stopped responding and shutdown procedures are ineffective, press and hold the power key for at least 10 seconds to turn off the computer.

*The antennas are not visible from the outside of the computer. For optimal transmission, keep the areas immediately around the antennas free from obstructions.

For wireless regulatory notices, see the section of the *Regulatory, Safety, and Environmental Notices* that applies to your country or region.

Touchpad

The touchpad settings and components are described here.

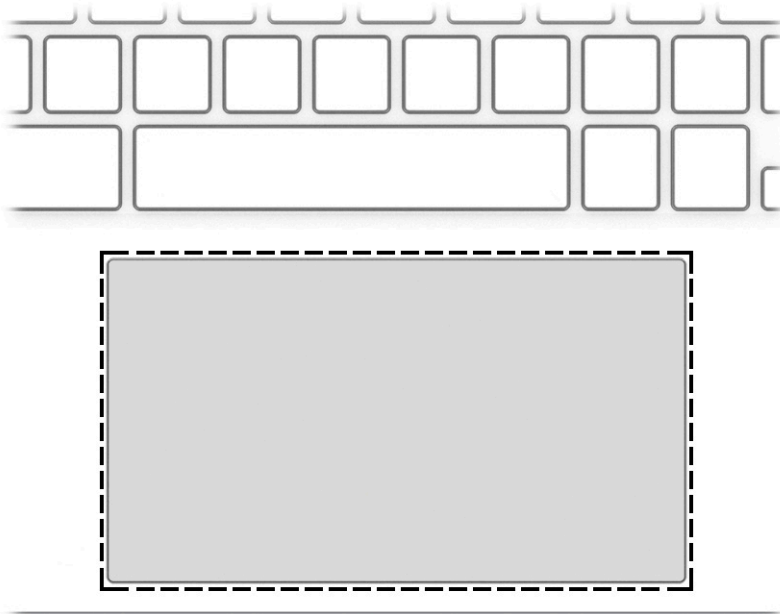

Table 2-4 Touchpad component and description

Component	Description
Touchpad zone	Reads your finger gestures to move the pointer or activate items on the screen.

Special keys

Use the illustration and table to locate the special keys.

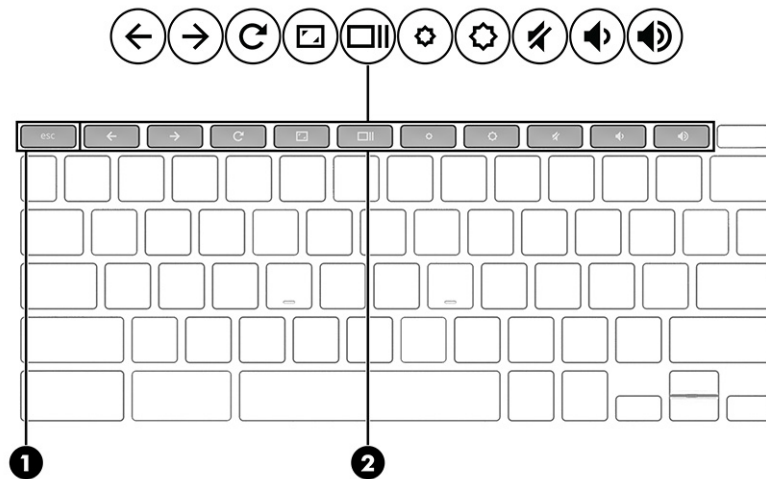

Table 2-5 Special keys and their descriptions

Component	Description
(1) <code>esc</code> key	Activates certain computer functions when pressed in combination with other keys, such as <code>tab</code> or <code>shift</code> .
(2) Action keys	Execute frequently used system functions.

Bottom

Use the illustration and table to identify the bottom components.

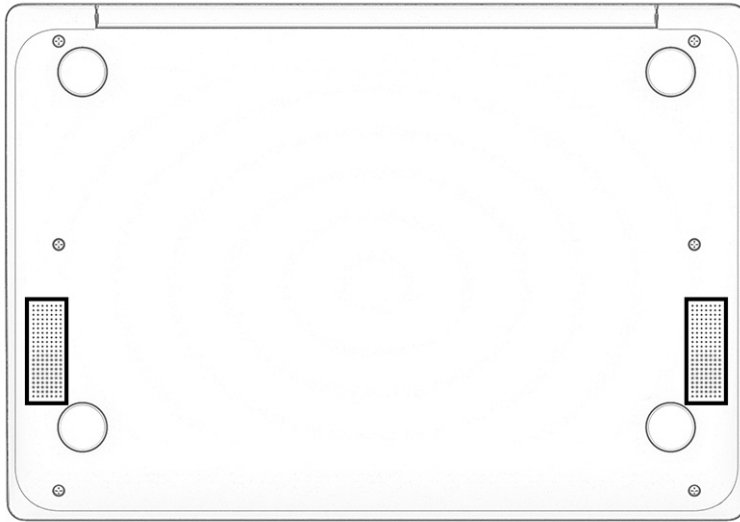

Table 2-6 Bottom components and description

Components	Description
Speakers	Produce sound.

3 Illustrated parts catalog

Use this table to determine the spare parts that are available for the computer.

Computer major components

To identify the computer major components, use this illustration and table.

 **NOTE:** HP continually improves and changes product parts. For complete and current information about supported parts for your computer, go to <http://partsurfer.hp.com>, select your country or region, and then follow the on-screen instructions.

 **NOTE:** Details about your computer, including model, serial number, product key, and length of warranty, are on the service tag at the bottom of your computer.

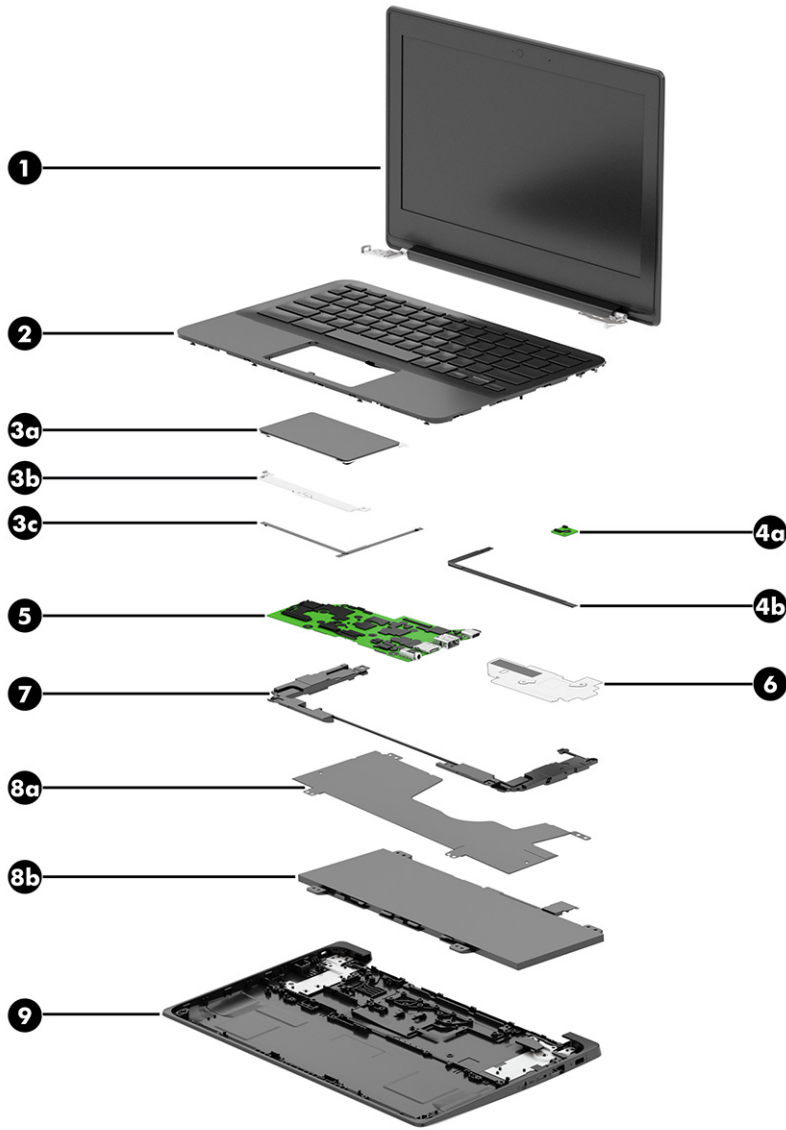

Table 3-1 Computer major component descriptions and part numbers

Item	Component	Spare part number
(1)	Display assembly	
	NOTE: Display spare parts are available as subcomponents, not as whole units. Display subcomponent spare parts are available. For spare part information, see Display assembly subcomponents on page 13 .	
(2)	Top cover/keyboard in jet black finish (includes keyboard cable):	
	For use in Belgium	M44258-A41
	For use in Brazil	M44258-201
	For use in Canada	M44258-DB1
	For use in the Czech Republic and Slovakia	M44258-FL1
	For use in Denmark, Finland, and Norway	M44258-DH1

Table 3-1 Computer major component descriptions and part numbers (continued)

Item	Component	Spare part number
	For use in France	M44258-051
	For use in Germany	M44258-041
	For use in Israel	M44258-BB1
	For use in Italy	M44258-061
	For use in Japan	M44258-291
	For use in Latin America	M44258-161
	For use in the Netherlands	M44258-B31
	For use in Portugal	M44258-131
	For use in Romania	M44258-271
	For use in Russia	M44258-251
	For use in Saudi Arabia	M44258-171
	For use in Slovenia	M44258-BA1
	For use in South Korea	M44258-AD1
	For use in Spain	M44258-071
	For use in Sweden and Finland	M44258-B71
	For use in Switzerland	M44258-BG1
	For use in Taiwan	M44258-AB1
	For use in Thailand	M44258-281
	For use in Turkey	M44258-141
	For use in the United Kingdom	M44258-031
	For use in the United States	M44258-001
	Top cover/keyboard in nautical teal finish (includes keyboard cable):	
	For use in Belgium	M44259-A41
	For use in Brazil	M44259-201
	For use in Canada	M44259-DB1
	For use in the Czech Republic and Slovakia	M44259-FL1
	For use in Denmark, Finland, and Norway	M44259-DH1
	For use in France	M44259-051
	For use in Germany	M44259-041
	For use in Israel	M44259-BB1
	For use in Italy	M44259-061
	For use in Japan	M44259-291
	For use in Latin America	M44259-161

Table 3-1 Computer major component descriptions and part numbers (continued)

Item	Component	Spare part number
	For use in the Netherlands	M44259-B31
	For use in Portugal	M44259-131
	For use in Romania	M44259-271
	For use in Russia	M44259-251
	For use in Saudi Arabia	M44259-171
	For use in Slovenia	M44259-BA1
	For use in South Korea	M44259-AD1
	For use in Spain	M44259-071
	For use in Sweden and Finland	M44259-B71
	For use in Switzerland	M44259-BG1
	For use in Taiwan	M44259-AB1
	For use in Thailand	M44259-281
	For use in Turkey	M44259-141
	For use in the United Kingdom	M44259-031
	For use in the United States	M44259-001
(3a)	Touchpad:	
	NOTE: The touchpad spare part kit does not include the touchpad bracket, touchpad bracket rubber, or touchpad cable. The touchpad bracket is available using spare part number L89791-001. The touchpad bracket rubber is available using spare part number L89786-001. The touchpad cable is included in the Cable Kit, spare part number M44247-001.	
	In jet black finish	M44244-001
	In nautical teal finish	M44245-001
(3b)	Touchpad bracket	L89791-001
	Touchpad bracket rubber (not illustrated)	L89786-001
(3c)	Touchpad cable	
	NOTE: The touchpad cable is included in the Cable Kit, spare part number M44247-001.	
(4a)	Sensor board	M44240-001
	NOTE: The sensor board spare part kit does not include the sensor board cable. The sensor board cable is included in the Cable Kit, spare part number M44247-001.	
(4b)	Sensor board cable (includes double-sided adhesive)	
	NOTE: The sensor board cable is included in the Cable Kit, spare part number M44247-001.	
(5)	System board (includes a Mediatek Arm Cortex-A MT8183 2.00 GHz integrated processor (8 core), a graphics subsystem with unified memory architecture (UMA) memory, replacement thermal material, and the Chrome operating system)	
	Equipped with 8 GB of system memory and 64 GB of eMMC system storage	M44239-001
	Equipped with 4 GB of system memory and 64 GB of eMMC system storage	M44237-001
	Equipped with 8 GB of system memory and 32 GB of eMMC system storage	M44238-001

Table 3-1 Computer major component descriptions and part numbers (continued)

Item	Component	Spare part number
	Equipped with 4 GB of system memory and 32 GB of eMMC system storage	M44236-001
	System board I/O bracket (not illustrated)	M45808-001
	WLAN module bracket (not illustrated)	M45807-001
(6)	Heat sink (includes replacement thermal material)	M44241-001
(7)	Speaker (includes left and right speakers and cables)	M44246-001
(8a)	Battery shield	L98587-001
(8b)	Battery (2 cell, 47 Whr, 6.15 Ahr, Li)	L75783-005
	Battery tape (not illustrated)	L14905-001
(9)	Bottom cover	
	In jet black finish	M44242-001
	In nautical teal finish	M44243-001

Display assembly subcomponents

To identify the display assembly subcomponents, use this illustration and table.

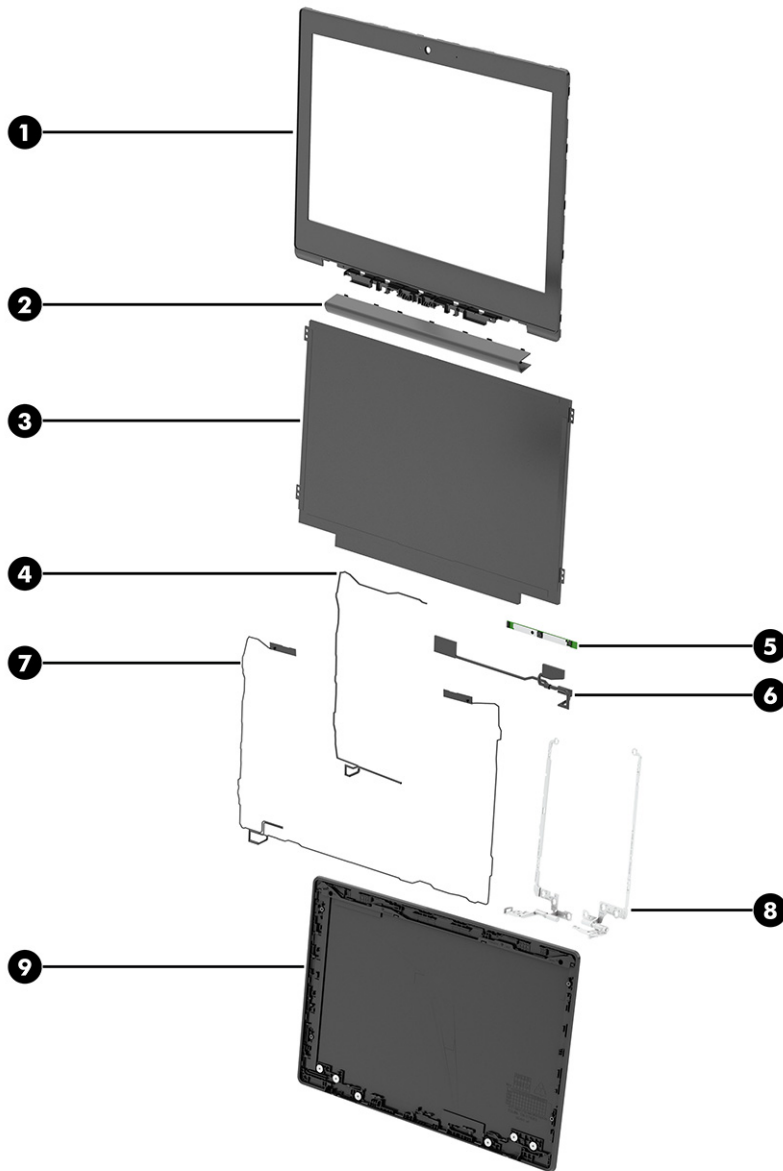

Table 3-2 Display component descriptions and part numbers

Item	Component	Spare part number
(1)	Display bezel (includes double-sided adhesive)	L89773-001
(2)	Display hinge cap	L44252-001
	Display panel bracket (not illustrated)	L89774-001
(3)	Display panel (29.5 cm (11.6 in):	
	LCD, HD (1366×768), antiglare, WLED, UWVA, 50% CG, eDP 1.2 without PSR, slim touchscreen display panel; typical brightness: 220 nits	M44257-001
	LCD, HD (1366×768), antiglare, WLED, UWVA, 50% CG eDP, slim non-touchscreen display panel; typical brightness: 220 nits	M44256-001
	LCD, HD (1366×768), antiglare, WLED, SVA, 45% CG, eDP, slim non-touchscreen display panel; typical brightness: 220 nits	M44255-001

Table 3-2 Display component descriptions and part numbers (continued)

Item	Component	Spare part number
(4)	Webcam/microphone module cable (included in the Cable Kit, spare part number M44247-001, includes double-sided adhesive)	
(5)	Webcam/microphone module (includes double-sided adhesive)	M44253-001
	NOTE: The webcam/microphone module spare part kit does not include the webcam/microphone module cable. The webcam/microphone module cable is included in the Cable Kit, spare part number M44247-001.	
(6)	Display panel cable	
	For use only on computer models equipped with a touchscreen display assembly	M48566-001
	For use only on computer models equipped with a non-touchscreen display assembly	M48567-001
(7)	Wireless antenna (included in the display back cover spare part kit, includes left and right wireless antenna cables and transceivers and double-sided adhesive)	
(8)	Display hinges (2, includes left and right hinges)	M44251-001
(9)	Display back cover (includes wireless antenna cables and transceivers):	
	In jet black finish	M44249-001
	In nautical teal finish	M44250-001

Cables

To identify the cables, use this illustration and table.

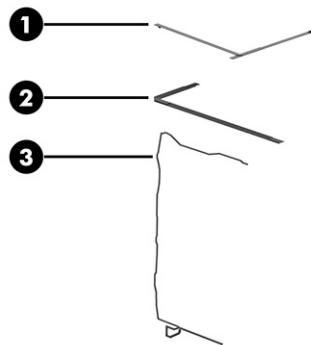

Table 3-3 Cable descriptions and part numbers

Item	Component	Spare part number
	The cables listed in this table are available in the Cable Kit, spare part number M44247-001.	
(1)	Sensor board cable	
(2)	Touchpad cable	
(3)	Webcam/microphone module cable	

Miscellaneous parts

To identify the miscellaneous parts, use this table.

Table 3-4 Miscellaneous part descriptions and part numbers

Component	Spare part number
45 W, USB Type-C, AC adapter (non-PFC, 1.8 m, 3 pin)	L43407-001
Hardware Kit	M44248-001
Power cord (C5, 1.0 m, conventional with sticker)	
For use in Argentina	L19357-001
For use in Australia	L19358-001
For use in Brazil	L19359-001
For use in Denmark	L19360-001
For use in Europe	L19361-001
For use in India	L19363-001
For use in Israel	L19362-001
For use in Italy	L19364-001
For use in Japan	L19365-001
For use in North America	L19367-001
For use in South Africa	L19369-001
For use in Switzerland	L19370-001
For use in Taiwan	L19372-001
For use in Thailand	L19371-001
For use in the United Kingdom	L19373-001
Screw Kit	M44254-001
Tape Kit	M47412-001

4 Removal and replacement procedures preliminary requirements

Use this information to properly prepare to disassemble and reassemble the computer.

Tools required

You need the following tools to complete the removal and replacement procedures:

- Tweezers
- Nonconductive, nonmarking pry tool
- Magnetic Phillips P1 screwdriver

Service considerations

The following sections include some of the considerations that you must keep in mind during disassembly and assembly procedures.

 **NOTE:** As you remove each subassembly from the computer, place the subassembly (and all accompanying screws) away from the work area to prevent damage.

Plastic parts

Using excessive force during disassembly and reassembly can damage plastic parts.

Cables and connectors

Handle cables with extreme care to avoid damage.

 **IMPORTANT:** When servicing the computer, be sure that cables are placed in their proper locations during the reassembly process. Improper cable placement can damage the computer.

Apply only the tension required to unseat or seat the cables during removal and insertion. Handle cables by the connector whenever possible. In all cases, avoid bending, twisting, or tearing cables. Be sure that cables are routed so that they cannot be caught or snagged as you remove or replace parts. Handle flex cables with extreme care; these cables tear easily.

Drive handling

Note the following guidelines when handling drives.

 **IMPORTANT:** Drives are fragile components. Handle them with care. To prevent damage to the computer, damage to a drive, or loss of information, observe these precautions:

Before removing or inserting a hard drive, shut down the computer. If you are unsure whether the computer is off or in Hibernation, turn the computer on, and then shut it down through the operating system.

Before handling a drive, be sure that you are discharged of static electricity. While handling a drive, avoid touching the connector.

Before removing an optical drive, be sure that a disc is not in the drive, and be sure that the optical drive tray is closed.

Handle drives on surfaces covered with at least 2.54 cm (1 inch) of shock-proof foam.

Avoid dropping drives from any height onto any surface.

After removing a hard drive or an optical drive, place it in a static-proof bag.

Avoid exposing an internal hard drive to products that have magnetic fields, such as monitors or speakers.

Avoid exposing a drive to temperature extremes or liquids.

If a drive must be mailed, place the drive in a bubble pack mailer or other suitable form of protective packaging, and label the package “FRAGILE.”

Electrostatic discharge information

A sudden discharge of static electricity from your finger or other conductor can destroy static-sensitive devices or microcircuitry. Often the spark is neither felt nor heard, but damage occurs. An electronic device exposed to electrostatic discharge (ESD) might not appear to be affected at all and can work perfectly throughout a normal cycle. The device might function normally for a while, but it has been degraded in the internal layers, reducing its life expectancy.

Networks built into many integrated circuits provide some protection, but in many cases, the discharge contains enough power to alter device parameters or melt silicon junctions.

 **IMPORTANT:** To prevent damage to the device when you remove or install internal components, observe these precautions:

Keep components in their electrostatic-safe containers until you are ready to install them.

Before touching an electronic component, discharge static electricity by using the guidelines described [Personal grounding methods and equipment on page 20](#).

Avoid touching pins, leads, and circuitry. Handle electronic components as little as possible.

If you remove a component, place it in an electrostatic-safe container.

Generating static electricity

Follow these static electricity guidelines.

- Different activities generate different amounts of static electricity.
- Static electricity increases as humidity decreases.

Table 4-1 Static electricity occurrence based on activity and humidity

Event	Relative humidity		
	55%	40%	10%
Walking across carpet	7,500 V	15,000 V	35,000 V
Walking across vinyl floor	3,000 V	5,000 V	12,000 V
Motions of bench worker	400 V	800 V	6,000 V
Removing DIPs (dual in-line packages) from plastic tube	400 V	700 V	2,000 V
Removing DIPs from vinyl tray	2,000 V	4,000 V	11,500 V
Removing DIPs from polystyrene foam	3,500 V	5,000 V	14,500 V
Removing bubble pack from PCB (printed circuit board)	7,000 V	20,000 V	26,500 V
Packing PCBs in foam-lined box	5,000 V	11,000 V	21,000 V

Multiple electric components can be packaged together in plastic tubes, trays, or polystyrene foam.

 **NOTE:** As little as 700 V can degrade a product.

Preventing electrostatic damage to equipment

Many electronic components are sensitive to ESD. Circuitry design and structure determine the degree of sensitivity. The following packaging and grounding precautions are necessary to prevent static electricity damage to electronic components.

- To avoid hand contact, transport products in static-safe containers such as tubes, bags, or boxes.
- Protect all electrostatic parts and assemblies with conductive or approved containers or packaging.
- Keep electrostatic-sensitive parts in their containers until they arrive at static-free stations.
- Place items on a grounded surface before removing them from their container.
- Always be properly grounded when touching a sensitive component or assembly.
- Avoid contact with pins, leads, or circuitry.
- Place reusable electrostatic-sensitive parts from assemblies in protective packaging or conductive foam.

Personal grounding methods and equipment

Using certain equipment can prevent static electricity damage to electronic components.

- **Wrist straps** are flexible straps with a maximum of $1\text{ M}\Omega \pm 10\%$ resistance in the ground cords. To provide proper ground, a strap must be worn snug against bare skin. The ground cord must be connected and fit snugly into the banana plug connector on the grounding mat or workstation.
- **Heel straps/Toe straps/Boot straps** can be used at standing workstations and are compatible with most types of shoes or boots. On conductive floors or dissipative floor mats, use them on both feet with a maximum of $1\text{ M}\Omega \pm 10\%$ resistance between the operator and ground.

Table 4-2 Static shielding protection levels

Static shielding protection levels	
Method	Voltage
Antistatic plastic	1,500
Carbon-loaded plastic	7,500
Metallized laminate	15,000

Grounding the work area

To prevent static damage at the work area, follow these precautions.

- Cover the work surface with approved static-dissipative material.
- Use a wrist strap connected to a properly grounded work surface and use properly grounded tools and equipment.
- Use static-dissipative mats, foot straps, or air ionizers to give added protection.
- Handle electrostatic sensitive components, parts, and assemblies by the case or PCB laminate. Handle them only at static-free work areas.
- Turn off power and input signals before inserting and removing connectors or test equipment.

- Use fixtures made of static-safe materials when fixtures must directly contact dissipative surfaces.
- Keep the work area free of nonconductive materials, such as ordinary plastic assembly aids and polystyrene foam.
- Use conductive field service tools, such as cutters, screwdrivers, and vacuums.
- Avoid contact with pins, leads, or circuitry.

Recommended materials and equipment

HP recommends certain materials and equipment to prevent static electricity.

- Antistatic tape
- Antistatic smocks, aprons, or sleeve protectors
- Conductive bins and other assembly or soldering aids
- Conductive foam
- Conductive tabletop workstations with ground cord of $1\text{ M}\Omega \pm 10\%$ resistance
- Static-dissipative table or floor mats with hard tie to ground
- Field service kits
- Static awareness labels
- Wrist straps and footwear straps providing $1\text{ M}\Omega \pm 10\%$ resistance
- Material handling packages
- Conductive plastic bags
- Conductive plastic tubes
- Conductive tote boxes
- Opaque shielding bags
- Transparent metallized shielding bags
- Transparent shielding tubes

Cleaning your computer

Cleaning your computer regularly removes dirt and debris so that your device continues to operate at its best. Use the following information to safely clean the external surfaces of your computer.

Enabling HP Easy Clean (select products only)

HP Easy Clean helps you to avoid accidental input while you clean the computer surfaces. This software disables devices such as the keyboard, touch screen, and touchpad for a preset amount of time so that you can clean all computer surfaces.

1. Start HP Easy Clean in one of the following ways:
 - Select the **Start** menu, and then select **HP Easy Clean**.
– or –
 - Select the **HP Easy Clean** icon in the taskbar.
– or –
 - Select **Start**, and then select the **HP Easy Clean** tile.
2. Now that your device is disabled for a short period, see [Removing dirt and debris from your computer on page 22](#) for the recommended steps to clean the high-touch, external surfaces on your computer. After you remove the dirt and debris, you can also clean the surfaces with a disinfectant. See [Cleaning your computer with a disinfectant on page 23](#) for guidelines to help prevent the spread of harmful bacteria and viruses.

Removing dirt and debris from your computer

Here are the recommended steps to clean dirt and debris from your computer.

For computers with wood veneer, see [Caring for wood veneer \(select products only\) on page 24](#).

1. Wear disposable gloves made of latex (or nitrile gloves, if you are latex-sensitive) when cleaning the surfaces.
2. Turn off your device and unplug the power cord and other connected external devices. Remove any installed batteries from items such as wireless keyboards.

 **CAUTION:** To prevent electric shock or damage to components, never clean a product while it is turned on or plugged in.

3. Moisten a microfiber cloth with water. The cloth should be moist, but not dripping wet.

 **IMPORTANT:** To avoid damaging the surface, avoid abrasive cloths, towels, and paper towels.

4. Wipe the exterior of the product gently with the moistened cloth.

 **IMPORTANT:** Keep liquids away from the product. Avoid getting moisture in any openings. If liquid makes its way inside your HP product, it can cause damage to the product. Do not spray liquids directly on the product. Do not use aerosol sprays, solvents, abrasives, or cleaners containing hydrogen peroxide or bleach that might damage the finish.

5. Start with the display (if applicable). Wipe carefully in one direction, and move from the top of the display to the bottom. Finish with any flexible cables, like power cord, keyboard cable, and USB cables.

6. Be sure that surfaces have completely air-dried before turning the device on after cleaning.
7. Discard the gloves after each cleaning. Clean your hands immediately after you remove the gloves.

See [Cleaning your computer with a disinfectant on page 23](#) for recommended steps to clean the high-touch, external surfaces on your computer to help prevent the spread of harmful bacteria and viruses.

Cleaning your computer with a disinfectant

The World Health Organization (WHO) recommends cleaning surfaces, followed by disinfection, as a best practice for preventing the spread of viral respiratory illnesses and harmful bacteria.

After cleaning the external surfaces of your computer using the steps in [Removing dirt and debris from your computer on page 22](#), [Caring for wood veneer \(select products only\) on page 24](#), or both, you might also choose to clean the surfaces with a disinfectant. A disinfectant that is within HP's cleaning guidelines is an alcohol solution consisting of 70% isopropyl alcohol and 30% water. This solution is also known as rubbing alcohol and is sold in most stores.

Follow these steps when disinfecting high-touch, external surfaces on your computer:

1. Wear disposable gloves made of latex (or nitrile gloves, if you are latex-sensitive) when cleaning the surfaces.
2. Turn off your device and unplug the power cord and other connected external devices. Remove any installed batteries from items such as wireless keyboards.

 **CAUTION:** To prevent electric shock or damage to components, never clean a product while it is turned on or plugged in.

3. Moisten a microfiber cloth with a mixture of 70% isopropyl alcohol and 30% water. The cloth should be moist, but not dripping wet.

 **CAUTION:** Do not use any of the following chemicals or any solutions that contain them, including spray-based surface cleaners: bleach, peroxides (including hydrogen peroxide), acetone, ammonia, ethyl alcohol, methylene chloride, or any petroleum-based materials, such as gasoline, paint thinner, benzene, or toluene.

 **IMPORTANT:** To avoid damaging the surface, avoid abrasive cloths, towels, and paper towels.

4. Wipe the exterior of the product gently with the moistened cloth.

 **IMPORTANT:** Keep liquids away from the product. Avoid getting moisture in any openings. If liquid makes its way inside your HP product, it can cause damage to the product. Do not spray liquids directly on the product. Do not use aerosol sprays, solvents, abrasives, or cleaners containing hydrogen peroxide or bleach that might damage the finish.

5. Start with the display (if applicable). Wipe carefully in one direction, and move from the top of the display to the bottom. Finish with any flexible cables, like power cord, keyboard cable, and USB cables.
6. Be sure that surfaces have completely air-dried before turning the device on after cleaning.
7. Discard the gloves after each cleaning. Clean your hands immediately after you remove the gloves.

Caring for wood veneer (select products only)

Your product might feature high-quality wood veneer. As with all natural wood products, proper care is important for best results over the life of the product. Because of the nature of natural wood, you might see unique variations in the grain pattern or subtle variations in color, which are normal.

- Clean the wood with a dry, static-free microfiber cloth or chamois.
- Avoid cleaning products containing substances such as ammonia, methylene chloride, acetone, turpentine, or other petroleum-based solvents.
- Do not expose the wood to sun or moisture for long periods of time.
- If the wood becomes wet, dry it by dabbing with an absorbent, lint-free cloth.
- Avoid contact with any substance that might dye or discolor the wood.
- Avoid contact with sharp objects or rough surfaces that might scratch the wood.

See [Removing dirt and debris from your computer on page 22](#) for the recommended steps to clean the high-touch, external surfaces on your computer. After you remove the dirt and debris, you can also clean the surfaces with a disinfectant. See [Cleaning your computer with a disinfectant on page 23](#) for sanitizing guidelines to help prevent the spread of harmful bacteria and viruses.

Packaging and transporting guidelines

Follow these grounding guidelines when packaging and transporting equipment.

- To avoid hand contact, transport products in static-safe tubes, bags, or boxes.
- Protect ESD-sensitive parts and assemblies with conductive or approved containers or packaging.
- Keep ESD-sensitive parts in their containers until the parts arrive at static-free workstations.
- Place items on a grounded surface before removing items from their containers.
- Always be properly grounded when touching a component or assembly.
- Store reusable ESD-sensitive parts from assemblies in protective packaging or nonconductive foam.
- Use transporters and conveyors made of antistatic belts and roller bushings. Be sure that mechanized equipment used for moving materials is wired to ground and that proper materials are selected to avoid static charging. When grounding is not possible, use an ionizer to dissipate electric charges.

Accessing support information

Use this information to find the HP support that you need.

Table 4-3 Support information locations



Service consideration	Path to access information
Records of reported failure incidents stored on the computer	<p>Windows:</p> <p>Pre-operating system failures are logged in the BIOS Event Log. To view the BIOS Event Log:</p> <ol style="list-style-type: none">1. Press the power button.2. Immediately and repeatedly press esc when the power button light turns white. <p>NOTE: If you do not press esc at the appropriate time, you must restart the computer and again repeatedly press esc when the power button light turns white to access the utility.</p> <ol style="list-style-type: none">3. Press f10 to enter the BIOS setup.4. (On commercial products) Under the Main tab, select BIOS event log, and then select View BIOS Event Log. <p>- or -</p> <p>(On consumer products) Under the Main tab, select System Log.</p> <p>Post operating system failures are logged in the Event Viewer.</p> <ol style="list-style-type: none">1. Turn on the computer and allow the operating system to open.2. Click the search icon  in the taskbar.3. Type <code>Event Viewer</code>, and then press enter.4. Select the log from the left panel. Details display in the right panel. <p>Chrome:</p> <ol style="list-style-type: none">1. Go to support.google.com/chrome.2. Search <code>collect Chrome device logs</code>.
Technical bulletins	<p>To locate technical bulletins:</p> <ol style="list-style-type: none">1. Go to www.hp.com.2. Place the cursor over Problem solving to display more options.3. Select Support & Troubleshooting.4. Type the serial number, product number, or product name to go to the product support page.5. Select Advisories to view technical bulletins.

Table 4-3 Support information locations (continued)

Service consideration	Path to access information
Repair professionals	To locate repair professionals: <ol style="list-style-type: none"><li data-bbox="676 310 1439 340">1. Go to www.hp.com.<li data-bbox="676 361 1439 390">2. Place the cursor over Support resources to display more options.<li data-bbox="676 411 1439 441">3. Select Authorized service providers.
Component and diagnosis information, failure detection, and required action	To locate diagnosis information and actions: <ol style="list-style-type: none"><li data-bbox="676 512 1439 541">1. Go to http://www.hp.com/go/techcenter/pcdiags.<li data-bbox="676 562 1439 592">2. Select Get Support.<li data-bbox="676 613 1439 642">3. Near the bottom of the window, select Notebook PCs, and the select your location.

5 Removal and replacement procedures for authorized service provider parts

This chapter provides removal and replacement procedures for authorized service provider parts.

 **IMPORTANT:** Components described in this chapter should be accessed only by an authorized service provider. Accessing these parts can damage the computer or void the warranty.

 **NOTE:** Details about your computer, including model, serial number, product key, and length of warranty, are on the service tag at the bottom of your computer.

Component replacement procedures

To remove and replace computer components, use these procedures.

 **NOTE:** HP continually improves and changes product parts. For complete and current information about supported parts for your computer, go to <http://partsurfer.hp.com>, select your country or region, and then follow the on-screen instructions.

You must remove, replace, or loosen as many as 43 screws when you service the parts described in this chapter. Make special note of each screw size and location during removal and replacement.

Preparation for disassembly

To remove and replace computer components, use these procedures.

See [Removal and replacement procedures preliminary requirements on page 17](#) for initial safety procedures.

1. Turn off the computer. If you are unsure whether the computer is off or in Hibernation, turn the computer on, and then shut it down through the operating system.
2. Disconnect the power from the computer by unplugging the power cord from the computer.
3. Disconnect all external devices from the computer.

Top cover/keyboard

To remove the top cover/keyboard, use this procedure and illustration.

 **NOTE:** The top cover/keyboard spare part kit includes keyboard cable.

Table 5-1 Top cover/keyboard description and part numbers

For use in country/region	Spare part number	For use in country/region	Spare part number
Top cover/keyboard in jet black finish:			
For use in Belgium	M44258-A41	For use in Romania	M44258-271
For use in Brazil	M44258-201	For use in Russia	M44258-251
For use in Canada	M44258-DB1	For use in Saudi Arabia	M44258-171
For use in the Czech Republic and Slovakia	M44258-FL1	For use in Slovenia	M44258-BA1
For use in Denmark, Finland, and Norway	M44258-DH1	For use in South Korea	M44258-AD1
For use in France	M44258-051	For use in Spain	M44258-071
For use in Germany	M44258-041	For use in Sweden and Finland	M44258-B71
For use in Israel	M44258-BB1	For use in Switzerland	M44258-BG1
For use in Italy	M44258-061	For use in Taiwan	M44258-AB1
For use in Japan	M44258-291	For use in Thailand	M44258-281
For use in Latin America	M44258-161	For use in Turkey	M44258-141
For use in the Netherlands	M44258-B31	For use in the United Kingdom	M44258-031

Table 5-1 Top cover/keyboard description and part numbers (continued)

For use in country/region	Spare part number	For use in country/region	Spare part number
For use in Portugal	M44258-131	For use in the United States	M44258-001
Top cover/keyboard in nautical teal finish:			
For use in Belgium	M44259-A41	For use in Romania	M44259-271
For use in Brazil	M44259-201	For use in Russia	M44259-251
For use in Canada	M44259-DB1	For use in Saudi Arabia	M44259-171
For use in the Czech Republic and Slovakia	M44259-FL1	For use in Slovenia	M44259-BA1
For use in Denmark, Finland, and Norway	M44259-DH1	For use in South Korea	M44259-AD1
For use in France	M44259-051	For use in Spain	M44259-071
For use in Germany	M44259-041	For use in Sweden and Finland	M44259-B71
For use in Israel	M44259-BB1	For use in Switzerland	M44259-BG1
For use in Italy	M44259-061	For use in Taiwan	M44259-AB1
For use in Japan	M44259-291	For use in Thailand	M44259-281
For use in Latin America	M44259-161	For use in Turkey	M44259-141
For use in the Netherlands	M44259-B31	For use in the United Kingdom	M44259-031
For use in Portugal	M44259-131	For use in the United States	M44259-001

Before removing the top cover/keyboard, prepare the computer for disassembly ([Preparation for disassembly on page 28](#)).

Remove the top cover/keyboard:

1. Turn the computer upside down with the front toward you.
2. Remove the two Phillips PM2.0×8.7 screws **(1)** that secure the top cover/keyboard to the bottom cover.

3. Remove the four Phillips PM2.0×7.1 screws **(2)** that secure the top cover/keyboard to the bottom cover.

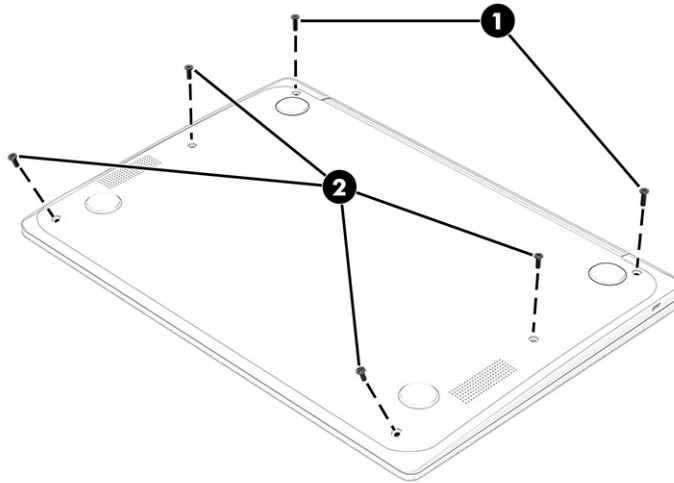

4. Turn the computer right side up with the front toward you.
5. Open the computer as far as it will open.
6. Use a nonmarking, nonconductive tool **(1)** to release the rear edge of the top cover/keyboard **(2)** from the computer.
7. Release the clear shield **(3)** that covers the keyboard cable and touchpad cable zero insertion force (ZIF) connectors on the system board.
8. Release the ZIF connector **(4)** to which the keyboard cable is connected, and then disconnect the keyboard cable from the system board.

9. Release the ZIF connector (5) to which the touchpad cable is connected, and then disconnect the touchpad cable from the system board.

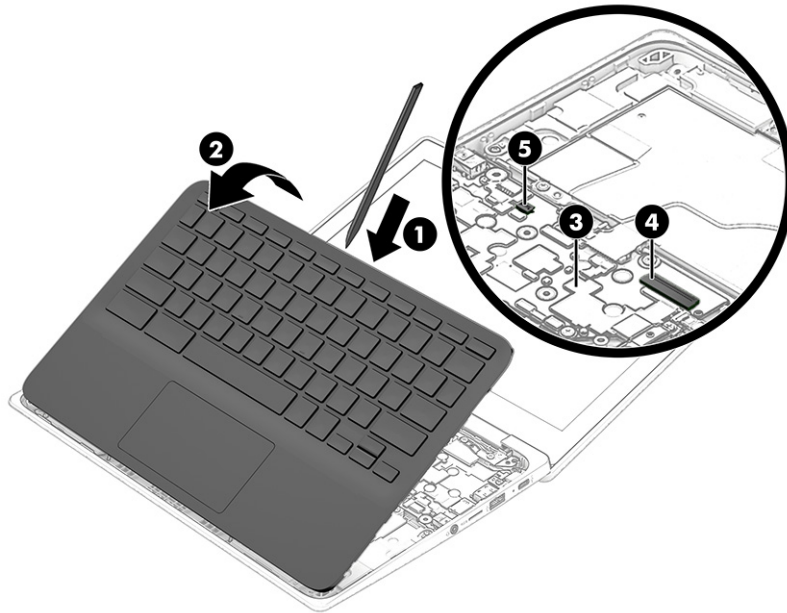

10. Remove the top cover/keyboard.

Reverse this procedure to install the top cover/keyboard.

Touchpad cable

To remove the touchpad cable, use this procedure and illustration.

 **NOTE:** The touchpad cable is included in the Cable Kit, spare part number M44247-001.

Before removing the touchpad cable, follow these steps:

1. Prepare the computer for disassembly ([Preparation for disassembly on page 28](#)).
2. Remove the top cover/keyboard ([Top cover/keyboard on page 28](#)).

Remove the touchpad cable:

1. Remove the retention pad (1) that secures the touchpad cable to the computer.
2. Detach the clear shield (2) that covers the touchpad cable ZIF connector on the system board.
3. Release the ZIF connector (3) to which the touchpad cable is connected, and then disconnect the touchpad cable from the touchpad.

4. Remove the touchpad cable (4).

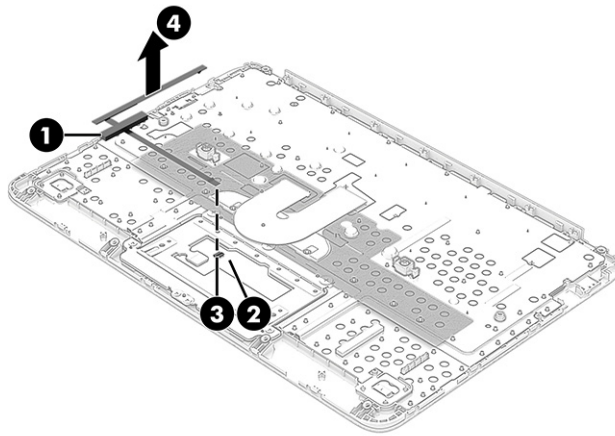

Reverse this procedure to install the touchpad cable

Touchpad

To remove the touchpad, use this procedure and illustration.

Table 5-2 Touchpad description and part numbers

Description	Spare part number
NOTE: The touchpad spare part kit does not include the touchpad bracket, touchpad bracket rubber, or touchpad cable. The touchpad bracket is available using spare part number L89791-001. The touchpad bracket rubber is available using spare part number L89786-001. The touchpad cable is included in the Cable Kit, spare part number M44247-001.	
In jet black finish	M44244-001
In nautical teal finish	M44245-001

Before removing the touchpad, follow these steps:

1. Prepare the computer for disassembly ([Preparation for disassembly on page 28](#)).
2. Remove the top cover/keyboard ([Top cover/keyboard on page 28](#)).

Remove the touchpad:

1. Remove the rubber pad (1) that secures the touchpad cable to the computer.
The rubber pad is available using spare part number L89786-001.
2. Remove the clear shield (2) that covers the touchpad screws.
3. Remove the three Phillips M2.0 × 2.2 broad head screws (3) that secure the touchpad to the computer.
4. Remove the four Phillips M2.0 × 2.8 screws (4) that secure the touchpad bracket and touchpad to the computer.
5. Remove the touchpad bracket (5).
The touchpad bracket is available using spare part number L89791-001.

6. Remove the touchpad (6).

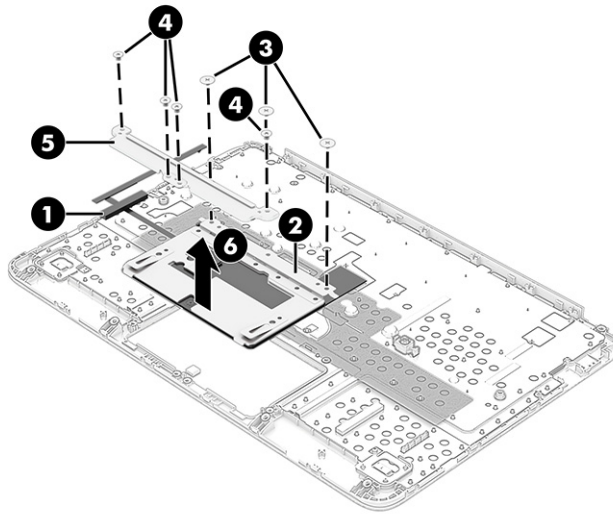

Reverse this procedure to install the touchpad.

Speakers

To remove the speakers, use this procedure and illustration.

Table 5-3 Speaker description and part number

Description	Spare part number
Speakers (include left and right speakers and cables)	M44246-001

Before removing the speakers, follow these steps:

1. Prepare the computer for disassembly ([Preparation for disassembly on page 28](#)).
2. Remove the top cover/keyboard ([Top cover/keyboard on page 28](#)).

Remove the speakers:

1. Detach the clear shield (1) that secures the battery cable to the system board.
2. Disconnect the battery cable (2) from the system board.
3. Remove the four Phillips M2.0 × 3.5 screws (3) that secure the battery shield to the computer.

4. Remove the battery shield (4).

The battery shield is available using spare part number L98587-001.

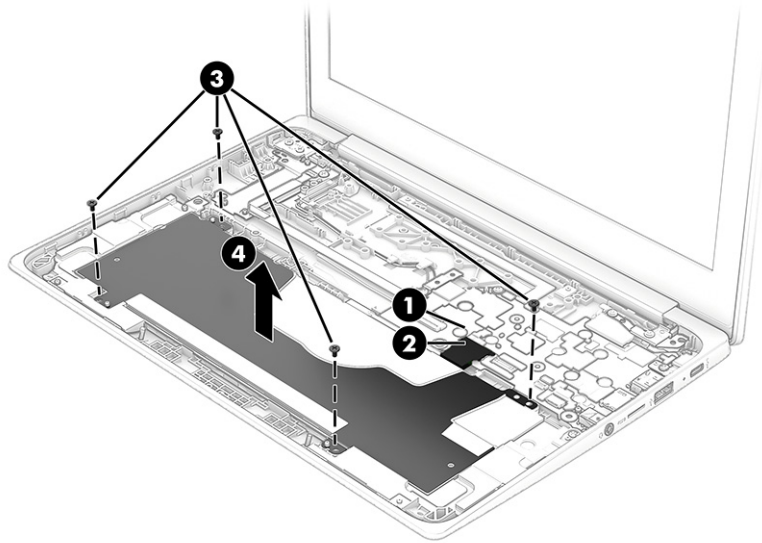

5. Detach the clear shield (1) that secures the speaker cable to the system board.
6. Disconnect the speaker cable (2) from the system board.
7. Release the speaker cable (3) from the retention clips built into the front edge of the battery.
8. Remove the Phillips M2.0 × 3.5 screws (4) that secures the right speaker to the computer.
9. Remove the speakers (5).

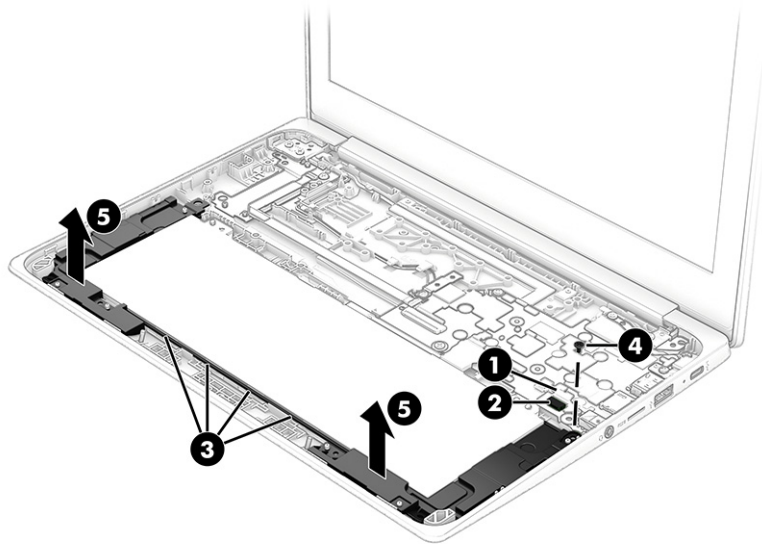

Reverse this procedure to install the speakers.

Battery

To remove the battery, use this procedure and illustration.

Table 5-4 Battery description and part number

Description	Spare part number
Battery (2 cell, 47 Whr, 6.15 Ahr, Li)	L75783-005

Before removing the battery, follow these steps:

1. Prepare the computer for disassembly ([Preparation for disassembly on page 28](#)).
2. Remove the top cover/keyboard ([Top cover/keyboard on page 28](#)).
3. Remove the speakers ([Speakers on page 33](#)).

Remove the battery:

- ▲ Remove the battery.

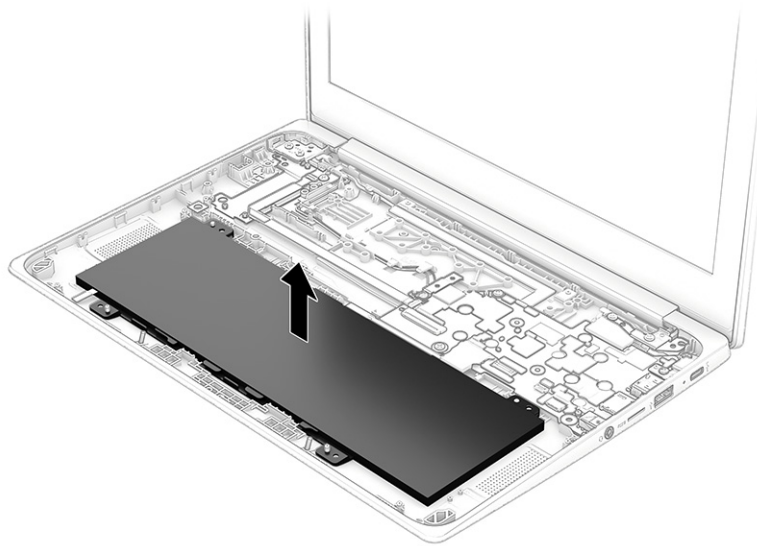

Reverse this procedure to install the battery.

Sensor board cable

To remove the sensor board cable, use this procedure and illustration.

 **NOTE:** The sensor board cable is included in the Cable Kit, spare part number M44247-001, and includes double-sided adhesive.

Before removing the sensor board cable, follow these steps:

1. Prepare the computer for disassembly ([Preparation for disassembly on page 28](#)).
2. Remove the top cover/keyboard ([Top cover/keyboard on page 28](#)).
3. Disconnect the battery cable from the system board ([Speakers on page 33](#)).

Remove the sensor board cable:

1. Detach the clear shield (1) that covers the sensor board cable ZIF connector on the system board.
2. Release the ZIF connector (2) to which the sensor board cable is connected, and then disconnect the sensor board cable from the system board.
3. Detach the clear shield (3) that covers the sensor board cable ZIF connector on the sensor board.
4. Release the ZIF connector (4) to which the sensor board cable is connected, and then disconnect the sensor board cable from the sensor board.
5. Detach the sensor board cable (5) from the computer. (The sensor board cable is attached to the computer with double-sided adhesive.)

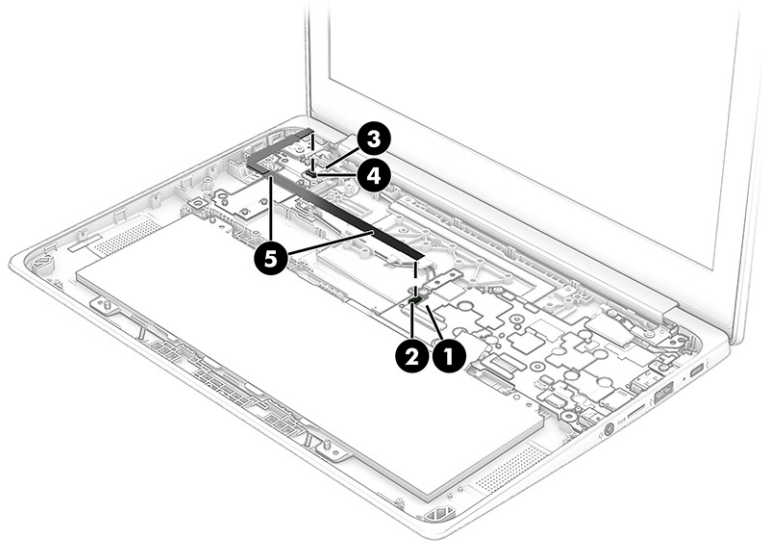

6. Remove the sensor board cable.

Reverse this procedure to install the sensor board cable.

Sensor board

To remove the sensor board, use this procedure and illustration.

Table 5-5 Sensor board description and part number

Description	Spare part number
Sensor board	M44240-001

NOTE: The sensor board spare part kit does not include the sensor board cable. The sensor board cable is included in the Cable Kit, spare part number M44247-001.

Before removing the sensor board, follow these steps:

1. Prepare the computer for disassembly ([Preparation for disassembly on page 28](#)).
2. Remove the top cover/keyboard ([Top cover/keyboard on page 28](#)).
3. Disconnect the battery cable from the system board ([Speakers on page 33](#)).

Remove the sensor board:

1. Detach the clear shield (1) that covers the sensor board cable ZIF connector on the system board.
2. Release the ZIF connector (2) to which the sensor board cable is connected, and then disconnect the sensor board cable from the system board.
3. Detach the sensor board cable (3) from the computer. (The sensor board cable is attached to the computer with double-sided adhesive.)
4. Remove the Phillips M2.0 × 3.5 screw (4) that secures the sensor board to the computer.
5. Remove the sensor board (5).

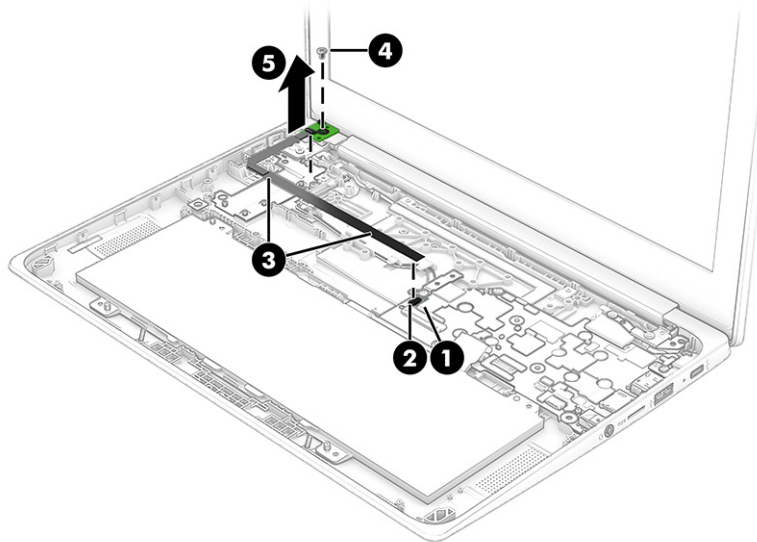

Reverse this procedure to install the sensor board.

System board

To remove the system board, use these procedures and illustrations.

Table 5-6 System board descriptions and part numbers

Description	Spare part number
System board (includes integrated Mediatek Arm Cortex-A MT8183 2.00 GHz integrated processor (8 core), a graphics subsystem with UMA memory, replacement thermal material, and the Chrome operating system):	
Equipped with 8 GB of system memory and 64 GB of eMMC system storage	M44239-001
Equipped with 4 GB of system memory and 64 GB of eMMC system storage	M44237-001
Equipped with 8 GB of system memory and 32 GB of eMMC system storage	M44238-001
Equipped with 4 GB of system memory and 32 GB of eMMC system storage	M44236-001

Before removing the system board, follow these steps:

1. Prepare the computer for disassembly ([Preparation for disassembly on page 28](#)).
2. Remove the top cover/keyboard ([Top cover/keyboard on page 28](#)).
3. Disconnect the battery cable from the system board ([Speakers on page 33](#)).

When you replace the system board, be sure to remove the heat sink (see [Heat sink on page 39](#) from the defective system board and install it on the replacement system board.

Remove the system board:

1. Remove the clear shield **(1)** that covers the system board connectors.
2. Disconnect the speaker cable **(2)** from the system board.
3. Release the ZIF connector **(3)** to which the sensor board cable is connected, and then disconnect the sensor board cable from the system board.
4. Remove the Phillips M2.0 × 3.5 screw **(4)** that secures the WLAN module bracket to the system board, and then remove the WLAN module bracket **(5)**.

The WLAN module bracket is available using spare part number M45807-001.

5. Carefully disconnect the two wireless antenna cables **(6)** from the WLAN module.



NOTE: The #1 white WLAN antenna cable connects to the WLAN module #1 Main terminal. The #2 black WLAN antenna cable connects to the WLAN module #1 Aux terminal.

6. Disconnect the webcam/microphone module cable **(7)** from the system board.
7. Release the retention bar **(8)** that secures the display panel cable to the system board, and then disconnect the display panel cable **(9)** from the system board.

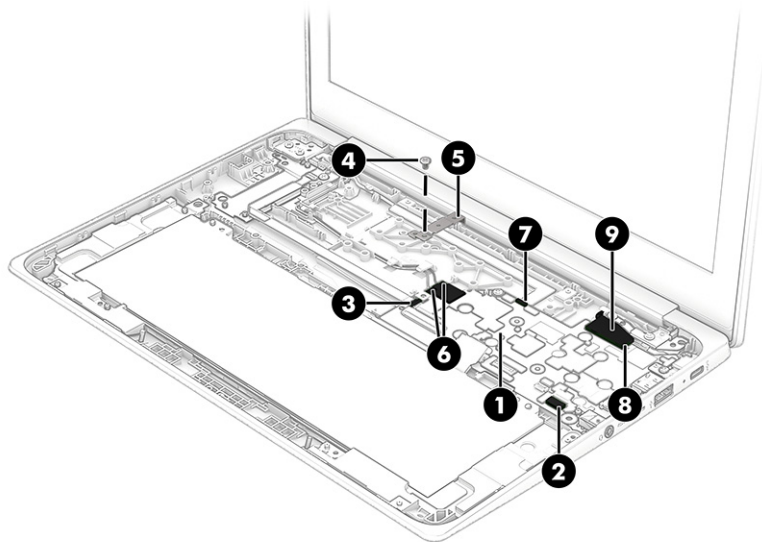

8. Remove the four Phillips M2.0 × 3.5 screws **(1)** that secure the system board to the computer.
9. Lift the left side of the system board **(2)** until it rests at an angle.

- Slide the system board (3) up and to the left at an angle to remove it.

 **NOTE:** When removing the system board, make note of the location of the I/O bracket (4).

The I/O bracket is available using spare part number M45808-001.

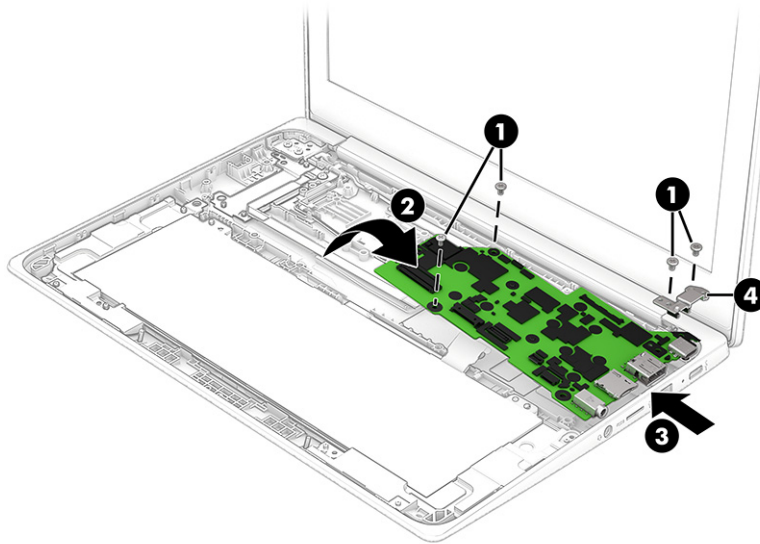

Reverse this procedure to install the system board.

Heat sink

To remove the heat sink, use these procedures and illustrations.

Table 5-7 Heat sink descriptions and part numbers

Description	Spare part number
Heat sink (includes replacement thermal material)	M44241-001

Before removing the heat sink, follow these steps:

- Prepare the computer for disassembly ([Preparation for disassembly on page 28](#)).
- Remove the top cover/keyboard ([Top cover/keyboard on page 28](#)).
- Disconnect the battery cable from the heat sink ([Speakers on page 33](#)).
- Remove the system board ([System board on page 37](#)).

Remove the heat sink:

- Turn the system board upside down with the front toward you.
- Remove the two Phillips M2.0 × 2.0 broad head screws (1) that secure the heat sink to the system board.

3. Remove the heat sink (2).

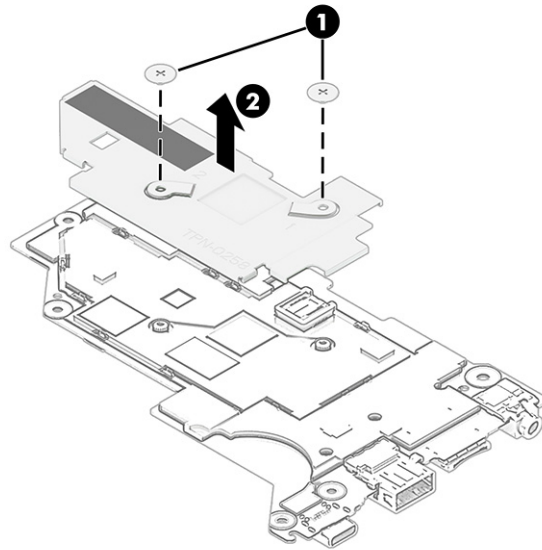

4. Each time the heat sink is removed, thoroughly clean the thermal material from the processor component (1) and the surface of the heat sink (2). Replacement thermal material is included with the heat sink and system board spare part kits.

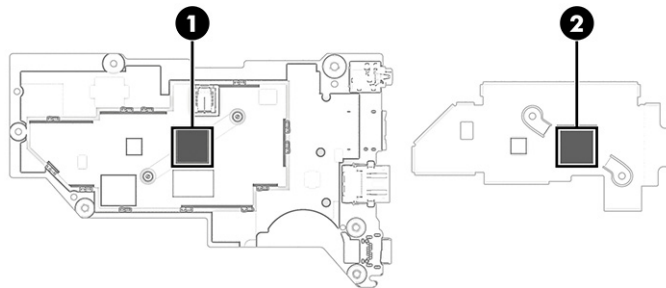

Reverse this procedure to install the heat sink.

29.5 cm (11.6 in) display assembly

To remove and disassemble the display assembly, use these procedures and illustrations.

Full hinge-up displays are not available as spare parts. Spare parts for displays are available only at the subcomponent level.

Before removing the display panel, follow these steps:

1. Prepare the computer for disassembly ([Preparation for disassembly on page 28](#)).
2. Remove the top cover/keyboard ([Top cover/keyboard on page 28](#)).
3. Disconnect the battery cable from the system board ([Speakers on page 33](#)).

Remove the display assembly:

1. Remove the clear shield **(1)** that covers the system board connectors.
2. Remove the Phillips M2.0 × 3.5 screw **(2)** that secures the WLAN module bracket to the system board, and then remove the WLAN module bracket **(3)**.

The WLAN module bracket is available using spare part number M45807-001.

3. Carefully disconnect the two wireless antenna cables **(4)** from the WLAN module.

 **NOTE:** The #1 white WLAN antenna cable connects to the WLAN module #1 Main terminal. The #2 black WLAN antenna cable connects to the WLAN module #1 Aux terminal.

4. Release the wireless antenna cables **(5)** from the retention clips built into the bottom cover.
5. Disconnect the webcam/microphone module cable **(6)** from the system board.
6. Detach the webcam/microphone module cable **(7)** from the bottom cover. (The webcam/microphone module cable is attached to the bottom cover with double-sided adhesive.)
7. Release the webcam/microphone module cable **(8)** from the retention clips built into the bottom cover.
8. Release the retention bar **(9)** that secures the display panel cable to the system board, and then disconnect the display panel cable **(10)** from the system board.
9. Release the display panel cable **(11)** from the retention clip built into the bottom cover.

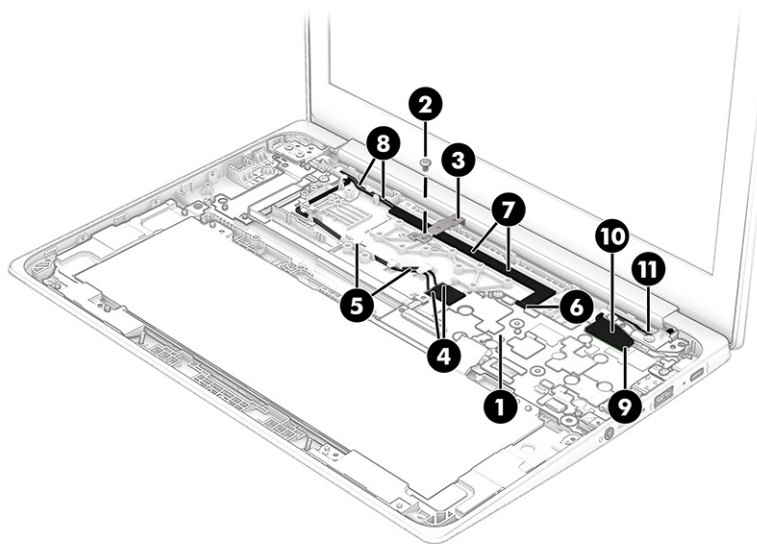

 **NOTE:** The display bezel is attached to the display assembly with double-sided tape. Use firm pressure when flexing the display bezel to remove it.

10. Carefully flex the inside edges of the top **(1)**, left **(2)** and right, and bottom edges **(3)** of the display bezel to detach it from the display assembly.

11. Remove the display bezel (4).

The display bezel is available using spare part number L89773-001.

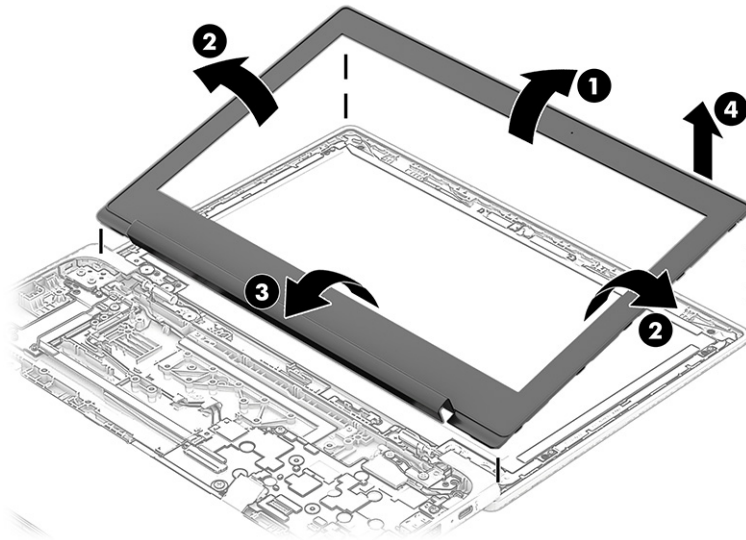

12. Remove the six Phillips M2.0 × 2.9 screws (1) that secure the display panel bracket and the display hinge brackets to the display back cover.

13. Remove the display panel bracket (2).

The display panel bracket is available using spare part number L89774-001.

14. Remove the six Phillips M2.0 × 2.9 broad head screws (3) that secure the display hinge brackets to the display back cover.

15. Release the display hinge brackets (4) from the display back cover by swinging them up and forward.

16. Release the wireless antenna cables, webcam/microphone module cable, and display panel cable from the display hinge areas (5).

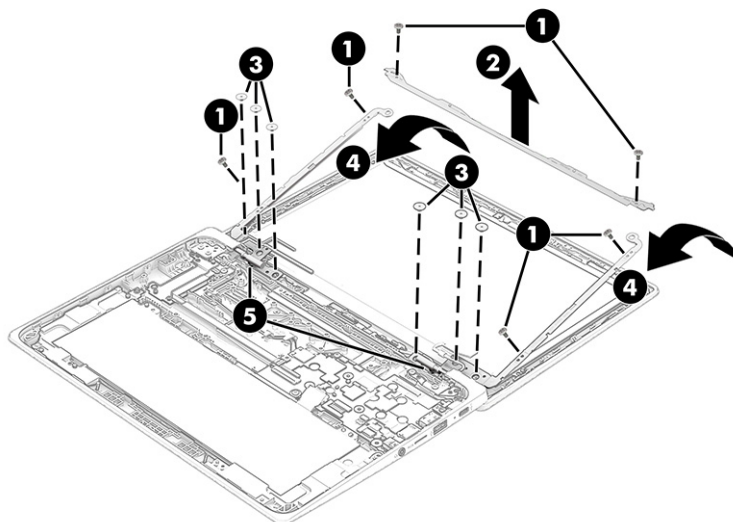

17. Release the display panel cable from the retention clips **(1)** and routing channel built into the bottom edge of the display back cover.
18. Remove the display panel **(2)**.
 - M44257-001: 29.5 cm (11.6 in), LCD, HD (1366×768), antiglare, WLED, UWVA, 50% CG, eDP 1.2 without PSR, slim touchscreen display panel; typical brightness: 220 nits
 - M44256-001: 29.5 cm (11.6 in), LCD, HD (1366×768), antiglare, WLED, UWVA, 50% CG eDP, slim non-touchscreen display panel; typical brightness: 220 nits
 - M44255-001: 29.5 cm (11.6 in), LCD, HD (1366×768), antiglare, WLED, SVA, 45% CG, eDP, slim non-touchscreen display panel; typical brightness: 220 nits

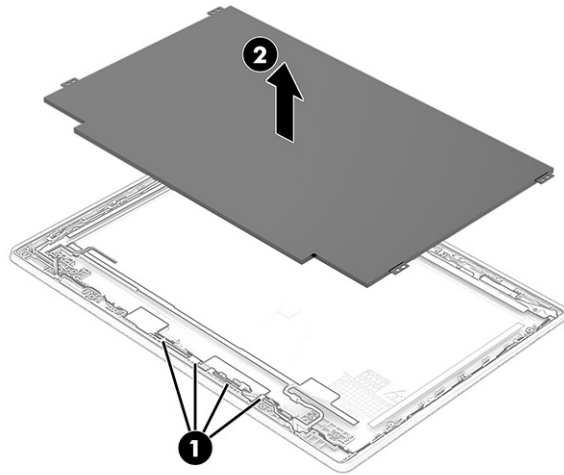

19. Turn the display panel upside down with the bottom edge toward you.
20. Release the grounding tape **(1)** that secures the display panel cable to the display panel.
21. Release the retention bar **(2)** that secures the display panel cable to the display panel.
22. Disconnect the display panel cable **(3)** from the display panel.

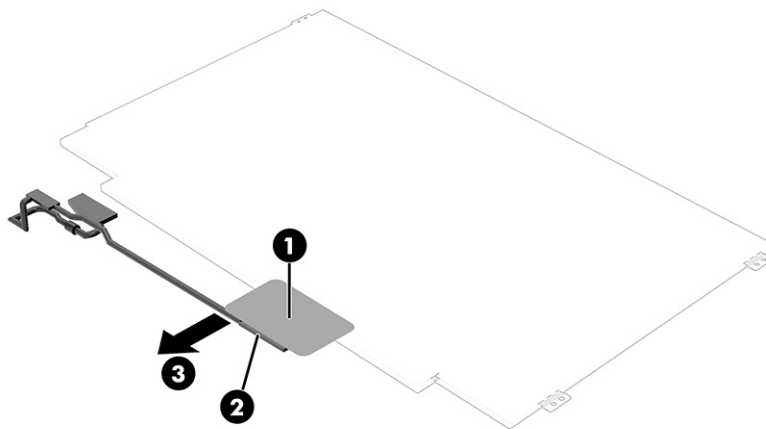

23. Remove the display panel cable.

24. Remove the webcam/microphone module cable from the retention clips (1) and routing channels built into the display back cover.
25. Detach the webcam/microphone module (2) from the display back cover. (The webcam/microphone module is attached to the display back cover with double-sided adhesive.)

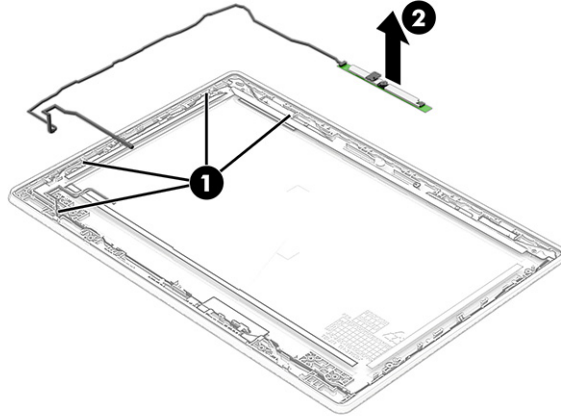

26. Release the ZIF connector to which the webcam/microphone module is connected, and then disconnect the webcam/microphone module cable from the webcam/microphone module.

The webcam/microphone module is available using spare part number M44253-001. The webcam/microphone module cable is included in the Cable Kit, spare part number M44247-001.



27. Remove the four Phillips M2.5 × 4.7 screws (1) that secure the display hinges to the bottom cover.

28. Rotate the hinges (2) out of the bottom cover.

The display hinges are available using spare part number M44251-001.

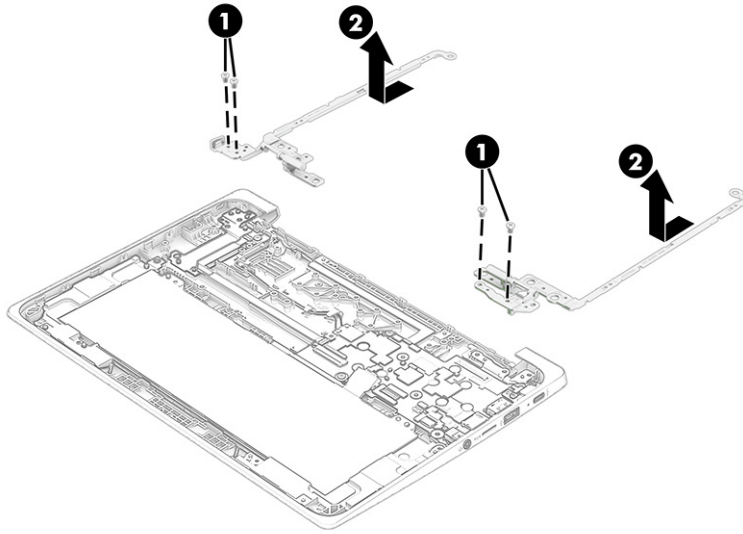

Reverse this procedure to reassemble and replace the display assembly.

6 Backing up, resetting, and recovering

This chapter provides information about processes that are standard procedure for most products.

Backing up

You can back up your data to an optional USB flash drive or SD memory card or through Google Drive.

For detailed information about creating a backup, go to <http://www.support.google.com>.

Resetting

A factory reset erases all the information on your computer hard drive, including all the files in the Downloads folder. Before you reset, make sure to back up your files to an optional USB flash drive, SD memory card, or through Google Drive. The factory reset will not delete any of your files on Google Drive or an external storage device.

Recovering

When your Chrome OS™ operating system is not working properly, you can perform a recovery. A recovery reinstalls the operating system and software programs and restores the original factory settings. Locally saved files and saved networks are deleted for all accounts. Your Google Accounts and any data synced to your Google Drive™ storage are not affected by a system recovery.



NOTE: For more information about performing a system recovery on your computer, go to <http://www.support.google.com>

Before beginning the recovery process, you need the following:

- A USB flash drive or SD memory card with a capacity of 4 GB or greater. All data is erased from this storage device when the recovery media is created, so back up any files from the device before you begin.
- A computer with internet access. You must also have administrative rights to the computer.
- Computer AC adapter. The computer must be plugged into AC power during recovery.
- The “Chrome OS is missing or damaged” screen displaying on your computer. If this message is not already displayed:
 - Turn on the computer, press and hold the **esc + f3** keys, and then press the power button. The computer restarts, and the screen shows the “Chrome OS is missing or damaged” screen.

Installing the Chromebook Recovery Utility

The Chromebook™ Recovery Utility is an app used to recover the original operating system and software programs that were installed at the factory. This utility can be installed from the Chrome Web Store on any computer.

Creating recovery media

Recovery media is used to recover the original operating system and software programs that were installed at the factory.

Recovering the Chrome operating system

To recover the Chrome operating system on your computer using the recovery media you created:

Setting up your computer after a reset or recovery

After a reset or recovery is complete, perform the initial setup process.

For details on setting up the computer, go to <http://www.support.google.com>.

Erase and reformat the recovery media

During the process of creating recovery media, the USB flash drive or SD memory card is formatted for use as a recovery tool. After you recover your computer, you will need to erase the recovery media if you want to reuse your USB flash drive or SD memory card to store other files. Use the steps in this section to erase the recovery media using the Chromebook Recovery Utility.

7 Specifications

This chapter provides specifications for your computer.

Computer specifications

This section provides specifications for your computer. When you travel with your computer, the computer dimensions and weights, as well as input power ratings and operating specifications, provide helpful information.

Table 7-1 Computer specifications

	Metric	U.S.
Dimensions		
Width	295.00 mm	11.61 in
Depth	205.30 mm	8.08 in
Height (front to back)	18.85 mm	0.74 in
Weight		
	1.34 kg	2.95 lb
Input power		
Operating voltage and current	19.5 V dc @ 2.31 A – 45 W	
	19.5 V dc @ 3.33 A – 65 W	
	19.5 V dc @ 4.62 A – 90 W	
	19.5 V dc @ 7.70 A – 150 W	
	19.5 V dc @ 10.3 A – 200 W	
Temperature		
Operating	5°C to 35°C	41°F to 95°F
Nonoperating	-20°C to 60°C	-4°F to 140°F
Relative humidity (noncondensing)		
Operating	10% to 90%	
Nonoperating	5% to 95%	
Maximum altitude (unpressurized)		
Operating	-15 m to 3,048 m	-50 ft to 10,000 ft

Table 7-1 Computer specifications (continued)

	Metric	U.S.
Nonoperating	-15 m to 12,192 m	-50 ft to 40,000 ft

NOTE: Applicable product safety standards specify thermal limits for plastic surfaces. The device operates well within this range of temperatures.

29.5 cm (11.6 in) display specifications

This section provides specifications for your display.

Table 7-2 Display specifications

	Metric	U.S.
Active diagonal size	29.5 cm	11.6 in
Resolution	1366 × 768 (HD panel)	
Surface treatment	Antiglare (HD panel)	
Brightness	220 nits (HD panel, 45% and 50% NTSC panels)	
Viewing angle	UWVA and SVA	
Backlight	WLED	
Display panel interface	eDP	

8 Statement of memory volatility

For general information regarding nonvolatile memory in HP business computers, and to restore nonvolatile memory that can contain personal data after the system has been turned off and the hard drive has been removed, use these instructions.

HP business computer products that use Intel®-based or AMD®-based system boards contain volatile DDR memory. The amount of nonvolatile memory present in the system depends upon the system configuration. Intel-based and AMD-based system boards contain nonvolatile memory subcomponents as originally shipped from HP, with the following assumptions:

- No subsequent modifications were made to the system.
- No applications, features, or functionality were added to or installed on the system.

Following system shutdown and removal of all power sources from an HP business computer system, personal data can remain on volatile system memory (DIMMs) for a finite period of time and also remains in nonvolatile memory. Use the following steps to remove personal data from the computer, including the nonvolatile memory found in Intel-based and AMD-based system boards.

 **NOTE:** If your tablet has a keyboard base, connect to the keyboard base before beginning steps in this chapter.

Current BIOS steps

Use these instructions to restore nonvolatile memory.

1. Follow these steps to restore the nonvolatile memory that can contain personal data. Restoring or reprogramming nonvolatile memory that does not store personal data is neither necessary nor recommended.

- a. Turn on or restart the computer, and then quickly press **esc**.

 **NOTE:** If the system has a BIOS administrator password, enter the password at the prompt.

- b. Select **Main**, select **Apply Factory Defaults and Exit**, and then select **Yes** to load defaults. The computer restarts.
- c. During the restart, press **esc** while the "Press the ESC key for Startup Menu" message is displayed at the bottom of the screen.

 **NOTE:** If the system has a BIOS administrator password, enter the password at the prompt.

- d. Select the **Security** menu, select **Restore Security Settings to Factory Defaults**, and then select **Yes** to restore security level defaults. The computer reboots.

- e. During the reboot, press **esc** while the "Press the ESC key for Startup Menu" message is displayed at the bottom of the screen.



NOTE: If the system has a BIOS administrator password, enter the password at the prompt.

- f. If an asset or ownership tag is set, select the **Security** menu and scroll down to the **Utilities** menu. Select **System IDs**, and then select **Asset Tracking Number**. Clear the tag, and then make the selection to return to the prior menu.
- g. If a DriveLock password is set, select the **Security** menu, and scroll down to **Hard Drive Utilities** under the **Utilities** menu. Select **Hard Drive Utilities**, select **DriveLock**, and then clear the check box for **DriveLock password on restart**. Select **OK** to proceed.
- h. Select the **Main** menu, and then select **Reset BIOS Security to factory default**. Select **Yes** at the warning message. The computer reboots.
- i. During the reboot, press **esc** while the "Press the ESC key for Startup Menu" message is displayed at the bottom of the screen.



NOTE: If the system has a BIOS administrator password, enter the password at the prompt.

- j. Select the **Main** menu, select **Apply Factory Defaults and Exit**, select **Yes** to save changes and exit, and then select **Shutdown**.
 - k. Reboot the system. If the system has a Trusted Platform Module (TPM), fingerprint reader, or both, one or two prompts will appear—one to clear the TPM and the other to Reset Fingerprint Sensor. Press or tap **f1** to accept or **f2** to reject.
 - l. Remove all power and system batteries for at least 24 hours.
2. Complete one of the following:
- Remove and retain the storage drive.
– or –
 - Clear the drive contents by using a third-party utility designed to erase data from an SSD.
– or –
 - Clear the contents of the drive by using the following BIOS Setup Secure Erase command option steps:

If you clear data using Secure Erase, you cannot recover it.

- a. Turn on or restart the computer, and then quickly press **esc**.
- b. Select the **Security** menu and scroll down to the **esc** menu.
- c. Select **Hard Drive Utilities**.
- d. Under **Utilities**, select **Secure Erase**, select the hard drive storing the data you want to clear, and then follow the on-screen instructions to continue.

– or –

Clear the contents of the drive using the following Disk Sanitizer commands steps:

- i. Turn on or restart the computer, and then quickly press **esc**.
- ii. Select the **Security** menu and scroll down to the **Utilities** menu.
- iii. Select **Hard Drive Utilities**.
- iv. Under **Utilities**, select **Disk Sanitizer**, select the hard drive with the data that you want to clear, and then follow the on-screen instructions to continue.

 **NOTE:** The amount of time it takes for Disk Sanitizer to run can take several hours. Plug the computer into an AC outlet before starting.

Nonvolatile memory usage

Use this table to troubleshooting nonvolatile memory usage.

Table 8-1 Troubleshooting steps for nonvolatile memory usage

Nonvolatile memory type	Amount (Size)	Does this memory store customer data?	Does this memory retain data when power is removed?	What is the purpose of this memory?	How is data entered into this memory?	How is this memory write-protected?
HP Sure Start flash (select models only)	8 MB	No	Yes	Provides protected backup of critical System BIOS code, EC firmware, and critical computer configuration data for select platforms that support HP Sure Start. For more information, see Using HP Sure Start (select products only) on page 59 .	Data cannot be written to this device via the host processor. The content is managed solely by the HP Sure Start Embedded Controller.	This memory is protected by the HP Sure Start Embedded Controller.
Real Time Clock (RTC) battery backed-up CMOS configuration memory	256 bytes	No	Yes	Stores system date and time and noncritical data.	RTC battery backed-up CMOS is programmed using Computer Setup (BIOS), or by changing the Windows date & time.	This memory is not write-protected.
Controller (NIC) EEPROM	64 KB (not customer accessible)	No	Yes	Stores NIC configuration and NIC firmware.	NIC EEPROM is programmed using a utility from the NIC vendor that can be run from DOS.	A utility must be used to write data to this memory and is available from the NIC vendor. Writing data to this ROM in an inappropriate manner will render the NIC non-functional.

Table 8-1 Troubleshooting steps for nonvolatile memory usage (continued)

Nonvolatile memory type	Amount (Size)	Does this memory store customer data?	Does this memory retain data when power is removed?	What is the purpose of this memory?	How is data entered into this memory?	How is this memory write-protected?
DIMM Serial Presence Detect (SPD) configuration data	256 bytes per memory module, 128 bytes programmable (not customer accessible)	No	Yes	Stores memory module information.	DIMM SPD is programmed by the memory vendor.	Data cannot be written to this memory when the module is installed in a computer. The specific write-protection method varies by memory vendor.
System BIOS	9 MB	Yes	Yes	Stores system BIOS code and computer configuration data.	System BIOS code is programmed at the factory. Code is updated when the system BIOS is updated. Configuration data and settings are entered using the Computer Setup (BIOS) or a custom utility.	NOTE: Writing data to this ROM in an inappropriate manner can render the computer non-functional. A utility must be used for writing data to this memory and is available on the HP website; go to http://www.hp.com/support . Select Find your product , and then follow the on-screen instructions.
Intel Management Engine Firmware (present only in select Elite or Z models. For more information, go to http://www.hp.com/support . Select Identify your product for manuals and specific product information , and then follow the on-screen instructions.)	1.5 MB or 7 MB	Yes	Yes	Stores Management Engine Code, Settings, Provisioning Data and iAMT third-party data store.	Management Engine Code is programmed at the factory. Code is updated via Intel secure firmware update utility. Unique Provisioning Data can be entered at the factory or by an administrator using the Management Engine (MEBx) setup utility. The third-party data store contents can be populated by a remote management console or local applications that have been registered by an administrator to have access to the space.	The Intel chipset is configured to enforce hardware protection to block all direct read-write access to this area. An Intel utility must be used for updating the firmware. Only firmware updates digitally signed by Intel can be applied using this utility.
Bluetooth flash (select products only)	2 megabits	No	Yes	Stores Bluetooth configuration and firmware.	Bluetooth flash is programmed at the factory. Tools for writing data to this memory are not publicly available but can be obtained from the silicon vendor.	A utility must be used for writing data to this memory and is made available through newer versions of the driver whenever the flash requires an upgrade.
802.11 WLAN EEPROM	4 kilobits to 8 kilobits	No	Yes	Stores configuration and calibration data.	802.11 WLAN EEPROM is programmed at the factory. Tools for writing data to this memory are not made public.	A utility must be used for writing data to this memory and is typically not made available to the public unless a firmware upgrade is necessary to address a unique issue.

Table 8-1 Troubleshooting steps for nonvolatile memory usage (continued)

Nonvolatile memory type	Amount (Size)	Does this memory store customer data?	Does this memory retain data when power is removed?	What is the purpose of this memory?	How is data entered into this memory?	How is this memory write-protected?
Camera (select products only)	64 kilobits	No	Yes	Stores camera configuration and firmware.	Camera memory is programmed using a utility from the device manufacturer that can be run from Windows.	A utility must be used for writing data to this memory and is typically not made available to the public unless a firmware upgrade is necessary to address a unique issue.
Fingerprint reader (select products only)	512 KB flash	Yes	Yes	Stores fingerprint templates.	Fingerprint reader memory is programmed by user enrollment in HP ProtectTools Security Manager.	Only a digitally signed application can make the call to write to the flash.

Questions and answers

Use this section to answer your questions about nonvolatile memory.

1. How can the BIOS settings be restored (returned to factory settings)?



IMPORTANT: The restore defaults feature does not securely erase any information on your hard drive. See question and answer 6 for steps to securely erase information.

The restore defaults feature does not reset the Custom Secure Boot keys. See question and answer 7 for information about resetting the keys.

- a. Turn on or restart the computer, and then quickly press **esc**.
- b. Select **Main**, and then select **Apply Factory Defaults and Exit**.

- c. Follow the on-screen instructions.
- d. Select **Main**, select **Save Changes and Exit**, and then follow the on-screen instructions.

2. What is a UEFI BIOS, and how is it different from a legacy BIOS?

The Unified Extensible Firmware Interface (UEFI) BIOS is an industry-standard software interface between the platform firmware and an operating system (OS). It replaces the older BIOS architecture but supports much of the legacy BIOS functionality.

Like the legacy BIOS, the UEFI BIOS provides an interface to display the system information and configuration settings and to change the configuration of your computer before an OS is loaded. BIOS provides a secure runtime environment that supports a Graphic User Interface (GUI). In this environment, you can use either a pointing device (touch screen, touchpad, pointing stick, or USB mouse) or the keyboard to navigate and make menu and configuration selections. The UEFI BIOS also contains basic system diagnostics.

The UEFI BIOS provides functionality beyond that of the legacy BIOS. In addition, the UEFI BIOS works to initialize the computer's hardware before loading and executing the OS; the runtime environment allows the loading and execution of software programs from storage devices to provide more functionality, such as advanced hardware diagnostics (with the ability to display more detailed system information) and advanced firmware management and recovery software.

HP has provided options in Computer Setup (BIOS) to allow you to run in legacy BIOS, if required by the operating system. Examples of this requirement would be if you upgrade or downgrade the OS.

3. Where is the UEFI BIOS located?

The UEFI BIOS is located on a flash memory chip. You must use a utility to write to the chip.

4. What kind of configuration data is stored on the DIMM Serial Presence Detect (SPD) memory module? How would this data be written?

The DIMM SPD memory contains information about the memory module, such as size, serial number, data width, speed and timing, voltage, and thermal information. This information is written by the module manufacturer and stored on an EEPROM. You cannot write to this EEPROM when the memory module is installed in a computer. Third-party tools do exist that can write to the EEPROM when the memory module is not installed in a computer. Various third-party tools are available to read SPD memory.

5. What is meant by "Restore the nonvolatile memory found in Intel-based system boards"?

This message relates to clearing the Real Time Clock (RTC) CMOS memory that contains computer configuration data.

6. How can the BIOS security be reset to factory defaults and erase the data?

 **IMPORTANT:** Resetting results in the loss of information.

These steps do not reset Custom Secure Boot Keys. See question and answer 7 for information about resetting the keys.

- a. Turn on or restart the computer, and then quickly press **esc**.
- b. Select **Main**, and then select **Reset Security to Factory Defaults**.

- c. Follow the on-screen instructions.
 - d. Select **Main**, select **Save Changes and Exit**, and then follow the on-screen instructions.
7. **How can the Custom Secure Boot Keys be reset?**
- Secure Boot is a feature to ensure that only authenticated code can start on a platform. If you enabled Secure Boot and created Custom Secure Boot Keys, disabling Secure Boot does not clear the keys. You must also select to clear the Custom Secure Boot Keys. Use the same Secure Boot access procedure that you used to create the Custom Secure Boot Keys, but select to clear or delete all Secure Boot Keys.
- a. Turn on or restart the computer, and then quickly press **esc**.
 - b. Select the **Security** menu, select **Secure Boot Configuration**, and then follow the on-screen instructions.
 - c. At the **Secure Boot Configuration** window, select **Secure Boot**, select **Clear Secure Boot Keys**, and then follow the on-screen instructions to continue.

Using HP Sure Start (select products only)

Select computer models are configured with HP Sure Start, a technology that continuously monitors your computer's BIOS for attacks or corruption.

If the BIOS becomes corrupted or is attacked, HP Sure Start restores the BIOS to its previously safe state, without user intervention. Those select computer models ship with HP Sure Start configured and enabled. HP Sure Start is configured and already enabled so that most users can use the HP Sure Start default configuration. Advanced users can customize the default configuration.

To access the latest documentation on HP Sure Start, go to <http://www.hp.com/support>.

9 Power cord set requirements

This chapter provides power cord requirements for countries and regions.

The wide-range input feature of the computer permits it to operate from any line voltage from 100 V ac to 120 V ac, or from 220 V ac to 240 V ac.

The three-conductor power cord set included with the computer meets the requirements for use in the country or region where the equipment is purchased.

Power cord sets for use in other countries or regions must meet the requirements of the country and region where the computer is used.

Requirements for all countries

These power cord requirements are applicable to all countries and regions.

- The length of the power cord set must be at least **1.0 m** (3.3 ft) and no more than **2.0 m** (6.5 ft).
- All power cord sets must be approved by an acceptable accredited agency responsible for evaluation in the country or region where the power cord set will be used.
- The power cord sets must have a minimum current capacity of 10 A and a nominal voltage rating of 125 V ac or 250 V ac, as required by the power system of each country or region.
- The appliance coupler must meet the mechanical configuration of an EN 60 320/IEC 320 Standard Sheet C13 connector for mating with the appliance inlet on the back of the computer.

Requirements for specific countries and regions

To determine power cord requirements for specific countries and regions, use this table.

Table 9-1 Power cord requirements for specific countries and regions

Country/region	Accredited agency	Applicable note number
Argentina	IRAM	1
Australia	SAA	1
Austria	OVE	1
Belgium	CEBEC	1
Brazil	ABNT	1
Canada	CSA	2

Table 9-1 Power cord requirements for specific countries and regions (continued)

Country/region	Accredited agency	Applicable note number
Chile	IMQ	1
Denmark	DEMKO	1
Finland	FIMKO	1
France	UTE	1
Germany	VDE	1
India	BIS	1
Israel	SII	1
Italy	IMQ	1
Japan	JIS	3
Netherlands	KEMA	1
New Zealand	SANZ	1
Norway	NEMKO	1
People's Republic of China	CCC	4
Saudi Arabia	SASO	7
Singapore	PSB	1
South Africa	SABS	1
South Korea	KTL	5
Sweden	SEMKO	1
Switzerland	SEV	1
Taiwan	BSMI	6
Thailand	TISI	1
United Kingdom	ASTA	1

Table 9-1 Power cord requirements for specific countries and regions (continued)

Country/region	Accredited agency	Applicable note number
United States	UL	2

1. The flexible cord must be Type H05VV-F, three-conductor, 0.75 mm² conductor size. Power cord set fittings (appliance coupler and wall plug) must bear the certification mark of the agency responsible for evaluation in the country or region where it will be used.
2. The flexible cord must be Type SVT/SJT or equivalent, No. 18 AWG, three-conductor. The wall plug must be a two-pole grounding type with a NEMA 5-15P (15 A, 125 V ac) or NEMA 6-15P (15 A, 250 V ac) configuration. CSA or C-UL mark. UL file number must be on each element.
3. The appliance coupler, flexible cord, and wall plug must bear a T mark and registration number in accordance with the Japanese Dentori Law. The flexible cord must be Type VCTF, three-conductor, 0.75 mm² or 1.25 mm² conductor size. The wall plug must be a two-pole grounding type with a Japanese Industrial Standard C8303 (7 A, 125 V ac) configuration.
4. The flexible cord must be Type RVV, three-conductor, 0.75 mm² conductor size. Power cord set fittings (appliance coupler and wall plug) must bear the CCC certification mark.
5. The flexible cord must be Type H05VV-F three-conductor, 0.75 mm² conductor size. KTL logo and individual approval number must be on each element. Approval number and logo must be printed on a flag label.
6. The flexible cord must be Type HVCTF three-conductor, 1.25 mm² conductor size. Power cord set fittings (appliance coupler, cable, and wall plug) must bear the BSMI certification mark.
7. For 127 V ac, the flexible cord must be Type SVT or SJT 3-conductor, 18 AWG, with plug NEMA 5-15P (15 A, 125 V ac), with UL and CSA or C-UL marks. For 240 V ac, the flexible cord must be Type H05VV-F three-conductor, 0.75 mm² or 1.00 mm² conductor size, with plug BS 1363/A with BSI or ASTA marks.

10 Recycling

When a nonrechargeable or rechargeable battery has reached the end of its useful life, do not dispose of the battery in general household waste. Follow the local laws and regulations in your area for battery disposal.

HP encourages customers to recycle used electronic hardware, HP original print cartridges, and rechargeable batteries. For more information about recycling programs, see the HP website at <http://www.hp.com/recycle>.

Index

A

- AC adapter light 4
- AC adapter, spare part number 16
- action keys 7
- antenna
 - location 5
- audio-out (headphone)/audio-in (microphone) combo jack 3

B

- battery light 4
- battery shield
 - removal 34
 - spare part number 34

C

- cables
 - spare part numbers 15
- camera 6
 - location 6
- camera light 6
- caring for your computer 22
- cautions
 - electrostatic discharge 17, 19
- cleaning your computer 22
 - caring for wood veneer 24
 - disinfecting 23
 - HP Easy Clean 22
 - removing dirt and debris 22
- components
 - bottom 8
 - display 5
 - left side 4
 - right side 3
- computer major components 9
- computer specifications 51
- creating recovery media 48

D

- display
 - specifications 51, 52
- display bezel
 - removal 41
 - spare part number 42
- display panel
 - removal 42
- display panel bracket
 - removal 42
 - spare part number 42
- display panel cable
 - removal 43

E

- electrostatic discharge (ESD) 17, 19
 - preventing damage 17, 19, 20
- erase and reformat recovery media
 - removal 48
- esc key 7

F

- factory reset 47

G

- grounding methods 17, 19, 20
- guidelines
 - packaging 17, 24
 - transporting 17, 24
 - workstation 17, 18

H

- hard drive
 - specifications 51
- Hardware Kit, spare part number 16
- heat sink
 - removal 39
 - spare part number 39

hinge

- removal 44
- spare part number 45
- HP Sure Start 53, 59

I

- illustrated parts catalog 9
- install
 - Chromebook Recovery Utility 48
 - Recovery Utility 48

J

- jacks
 - audio-out (headphone)/audio-in (microphone) combo 3

K

- keyboard
 - product description 1
- keys
 - action 7
 - esc 7
 - power 6

L

- lights
 - AC adapter 4
 - battery 4
 - camera 6

M

- memory
 - nonvolatile 53
 - volatile 53
- microphone 6
- microSD memory card reader 4

N

- nonvolatile memory 53

- P**
- packaging guidelines 17, 24
- pointing device, product description 1
- ports
 - product description 1
 - USB 4
 - USB Type-C power connector 4
- power cord
 - requirements for all countries 61
 - requirements for specific countries and regions 61
 - set requirements 61
- power cord, spare part numbers 16
- power key 6
- product description
 - keyboard 1
 - pointing device 1
 - ports 1

- R**
- recovering 48
- recovering Chrome operating system 48
- Recovery Utility 48
- removal and replacement procedures 28
- removing personal data from volatile system memory 53
- resetting 47

- S**
- Screw Kit, spare part number 16
- security cable slot 5
- sensor board
 - removal 36
 - spare part number 36
- sensor board cable
 - removal 35
 - spare part number 35
- setting up computer after reset or recovery 48
- speaker
 - removal 33
 - spare part number 33
- speakers
 - location 8
- specifications
 - computer 51
 - display 51, 52
 - hard drive 51
 - static electricity 17, 19
 - support information 24
 - system board
 - removal 37
 - spare part numbers 37
 - system memory, removing personal data from volatile 53

- T**
- Tape Kit, spare part number 16
- top cover/keyboard
 - removal 28
 - spare part numbers 28
- touchpad
 - removal 32
 - spare part numbers 32
- touchpad cable
 - removal 31
 - spare part number 15, 31
- touchpad zone 6
- transporting guidelines 17, 24

- U**
- USB board cable
 - spare part number 15
- USB port 4
- USB Type-C power connector and port 4

- W**
- webcam/microphone module
 - removal 44
 - spare part number 44
- webcam/microphone module cable
 - spare part number 44
- wireless antenna
 - location 5
- WLAN antenna
 - location 5
- WLAN module bracket
 - removal 38, 41
 - spare part number 38, 41
- workstation guidelines 17, 18